

**DESIGN OF A WI-FI BASED ELECTROCARDIOGRAPHY  
MONITORING SYSTEM**

by

**Mehmet Kocatürk**

B.S. in Electronics Engineering, Istanbul Technical University, 2004

Submitted to the Institute of Biomedical Engineering  
in partial fulfillment of the requirements  
for the degree of  
Master of Science  
in  
Biomedical Engineering

Boğaziçi University

June 2007

## ACKNOWLEDGMENTS

I would like to express my special thanks to Prof. Dr. Mehmed Özkan, for providing guidance throughout this project.

## ABSTRACT

### DESIGN OF A WI-FI BASED ELECTROCARDIOGRAPHY MONITORING SYSTEM

The objective of this project is to design a wireless ECG monitoring system which enables the tracking of ambulatory patients' cardiac activities on a central server. A developed software run on a server and the client devices on patients yield providing support for nearly real-time traceability of patient ECG data.

The software on the server, which is technically able to handle unlimited numbers of connections of client devices, appropriately communicates with the remote devices and provides plotting of electrocardiogram of a selected patient who is pre-registered with the software. The client device, carried by the patient, includes an ECG amplifier circuit which also includes necessary filters to avoid undesired signals, and manages analog to digital conversion of amplified ECG signal as well as its transmission to the server.

IEEE 802.11b, as the wireless communication protocol, opted and involved in this design for ensuring data transmission between client devices on patients and the server, has rapidly penetrated in applications in Machine to Machine (M2M) communicating product lines except medical ones. What is more, due to rapid penetration of 802.11x (Wi-Fi) which simplifies the adaptation of the client devices developed with this study to the currently established networks, the designed system, in the aim of wireless ECG monitoring, can be foreseen to supply high efficiency in the further products of several ECG monitoring applications.

**Keywords:** ECG, Wi-Fi, IEEE 802.11, Telemedicine.

## ÖZET

# Wİ-Fİ TEMELLİ ELEKTROKARDİYOĞRAFI GÖRÜNTÜLEME SİSTEMİ TASARIMI

Bu çalışmanın amacı, bir sunucu üzerinden gezici hastaların kardiyak aktivitelerinin izlenebilmesine olanak sağlayan kablosuz EKG görüntüleme sistemi tasarımıdır. Bu sistemin bileşenleri olarak, sunucu üzerinde çalışmakta bulunan bir yazılım ve hastalar üzerindeki istemciler yaklaşık gerçek zamanlı olarak EKG verisinin izlenmesini destekler.

Sunucu üzerindeki yazılım teknik olarak sınırsız sayıda istemciden gelen bağlantı talebini kabul edebilmekte, onlarla uygun bir şekilde haberleşmekte ve daha önceden yazılım üzerinde kayıtlı hastanın seçilmesiyle elektrokardiogramının çizilmesini sağlamaktadır. Hasta tarafından taşınan istemci cihaz, istemeyen sinyalleri filtreleyen bir EKG amplifikatör devresi içerir ve yükseltilmiş olan EKG sinyalinin analogdan sayısala dönüştürülmesinin yanında bunun sunucuya iletilmesini yönetir.

Kablosuz iletişim protokolü olarak, hastalar üzerindeki istemci cihazlarla sunucu arasındaki veri iletimini garanti etmek için seçilen ve bu tasarımda yer alan IEEE 802.11b, medikal ürünler haricinde makineden makineye iletişim yapabilen ürün gruplarında süratli bir şekilde yayılmıştır. Ayrıca, bu proje ile geliştirilen istemci cihazların mevcut şebekelere uyumunu kolaylaştıran 802.11x (Wi-Fi) protokolünün hızlı yayılımı sayesinde, kablosuz EKG izleme amacıyla tasarımı yapılan sistemin ileriki kablosuz ECG izleme ürünlerinde yüksek verimlilik getireceği öngörülebilmektedir.

**Anahtar Sözcükler:** ECG, Wi-Fi, IEEE 802.11, Teletıp.

## TABLE OF CONTENTS

ACKNOWLEDGMENTS . . . . .	iii
ABSTRACT . . . . .	iv
ÖZET . . . . .	v
LIST OF FIGURES . . . . .	viii
LIST OF TABLES . . . . .	ix
LIST OF SYMBOLS . . . . .	x
LIST OF ABBREVIATIONS . . . . .	xi
1. INTRODUCTION . . . . .	1
1.1 ECG and Telemedicine . . . . .	1
1.2 Motivation and Objectives . . . . .	2
1.3 Thesis Outline . . . . .	3
2. THE ELECTROCARDIOGRAM . . . . .	4
2.1 The Electrical Activity of Heart . . . . .	4
2.2 The Waves and Usefulness of the ECG . . . . .	5
3. THE CLIENT DEVICE DEVELOPMENT . . . . .	7
3.1 Hardware Design . . . . .	7
3.1.1 The Power Supply . . . . .	7
3.1.2 The ECG Amplifier and Filtering Network . . . . .	8
3.1.2.1 The Instrumentation Amplifier . . . . .	8
3.1.2.2 The Low-Pass Filter . . . . .	11
3.1.2.3 The High-Pass Filter . . . . .	12
3.1.2.4 The Non-Inverting Amplifier . . . . .	14
3.1.2.5 The Notch Filter . . . . .	15
3.1.3 The Microcontroller Unit . . . . .	17
3.1.4 The Embedded Wireless Networking Device . . . . .	18
3.2 Firmware Design . . . . .	19
3.2.1 Timer Implementation . . . . .	20
3.2.2 ADC Conversion Program Implementation . . . . .	20
3.2.3 UART Configuration and Utilization . . . . .	21

3.2.4	Configuration and Utilization of Embedded Wireless Module . . .	21
4.	SOFTWARE DEVELOPMENT FOR THE SERVER . . . . .	23
5.	SYSTEM ASSESSMENT AND FURTHER IMPROVEMENTS . . . . .	26
5.1	Signal Quality at the Output of Amplifier and Filtering Network . . . . .	26
5.2	Sampling Rate for ADC . . . . .	26
5.3	Power Consumption and Implementation of External SDD or RAM . . .	26
5.4	The Software on the Server . . . . .	27
5.5	Computerized ECG Signal Analysis and Diagnosis . . . . .	30
5.6	Conformity of Amplifier and Filtering Network to the European Standards	30
6.	CONCLUSION . . . . .	33
	APPENDIX A. SCHEMATIC FOR THE CLIENT DEVICE . . . . .	34
	APPENDIX B. SCHEMATIC FOR THE CLIENT DEVICE . . . . .	35
	APPENDIX C. FIRMWARE OF CLIENT DEVICE AND SOFTWARE FOR SERVER	
	36	
	REFERENCES . . . . .	37

## LIST OF FIGURES

Figure 2.1	Typical APs for the several nodes with the correlation to ECG.	4
Figure 2.2	Waves of the ECG.	5
Figure 2.3	Atrial tachycardia.	6
Figure 2.4	Myocardial ischaemia (ST segment depression).	6
Figure 3.1	The voltage regulation circuit.	7
Figure 3.2	The voltage divider circuit.	8
Figure 3.3	Gain configuration of INA118.	8
Figure 3.4	The components overview of the INA118.	9
Figure 3.5	Guarding and driven right leg circuit.	10
Figure 3.6	Connection configuration of the leads on DB9 connector.	11
Figure 3.7	The low-pass filter configuration.	11
Figure 3.8	Experimental frequency response of the low-pass filter.	12
Figure 3.9	The high-pass filter configuration.	13
Figure 3.10	Experimental frequency response of the high-pass filter.	14
Figure 3.11	Non-inverting amplifier configuration.	15
Figure 3.12	The notch filter configuration.	16
Figure 3.13	Experimental frequency response of the notch filter.	17
Figure 3.14	The PIC18LF4520 and its configuration.	18
Figure 3.15	The WiPort connector.	19
Figure 3.16	A snapshot of patient - client device MAC address registration.	21
Figure 4.1	A snapshot while selecting patient from the drop-down list.	23
Figure 4.2	The Central ECG Monitor software.	24
Figure 4.3	An overview of the overall system architecture.	25
Figure 5.1	Plotted ECG when the electrodes placed on the limbs.	28
Figure 5.2	Electrode connection diagrams on the limbs and the chest.	29
Figure 5.3	Plotted ECG when the electrodes placed on the chest and back.	29
Figure 5.4	High frequency response for the equipment.	32
Figure A.1	Schematic for the client device.	34
Figure B.1	PCB Layout for the client device.	35

## LIST OF TABLES

Table 1.1	Comparison of several available wireless protocols.	2
-----------	---	---

## LIST OF SYMBOLS

$V_{OUT}$	Output Voltage
$V_{IN}$	Input Voltage
$V_{REF}$	Reference Voltage
$V_{GND}$	Ground Voltage
$R_G$	Gain Resistor
$f_c$	Cut-off Frequency

## LIST OF ABBREVIATIONS

ADC	Analog / Digital Conversion
AP	Action Potential
AV	Atrioventricular
DC	Direct Current
SA	Sinoatrial
ECG	Electrocardiogram
IEEE	Institute of Electrical and Electronics Engineers
GND	Ground
IC	Integrated Circuit
ICD	In Circuit Debugger
IP	Internet Protocol
LA	Left Arm
LAN	Local Area Network
Mbps	Megabit(s) per Second
MAC	Media Access Control
MCU	Microcontroller Unit
RA	Right Arm
RF	Radio Frequency
RL	Right Leg
RX	Receive
TCP	Transmission Control Protocol
TX	Transmit
UART	Universal Asynchronous Receiver Transmitter
WLAN	Wireless Local Area Network

# 1. INTRODUCTION

## 1.1 ECG and Telemedicine

The remote ECG tracking and monitoring systems have recently been the efficient technique with respect to determining a patient's abnormal heart activities continuously since costs of patient hospitalization are increasing day by day and much more than those of remotely tracking. Besides, due to those solutions, neither a specialist is required to visit the patients in remote regions nor the patient has to be hospitalized in the hospital for a long tracking period to reveal suddenly and temporarily occurred heart activity abnormalities.

Holter devices, recording patients ECG data to be laterly loaded at hospital for investigation of a specialist, have been developed to achieve finding out a prospective problematic circumstance for heart activity. However, those devices have had a drawback in means of medical attention because of the fact that they are only able to provide ECG data to the hospital in a period of a few days that could be very late for an attention.

At this point, the necessity of wireless remote devices, which also supports the mobility of the patient, appears to yield cardiac data to be received by the specialist through the Internet or LAN of the health station to track the situation simultaneously and remotely.

Throughout this project, a remote device, including hardware and firmware design, and software to be run on a server, handling received ECG data from remote device, have been developed to satisfy realizing a remote ECG monitoring system. The hardware of the remote (client) device consists of an instrumentation amplifier, followed by high-pass, low-pass, notch filters, non-inverting amplifier stages. Besides this analog network, it also includes a microcontroller for succeeding analog to digital

conversion, managing configuration of a Wi-Fi module (embedded wireless device providing communication via protocol IEEE 802.11b) and data transmission between the server and remote device through this Wi-Fi module. The firmware embedded on the microcontroller provides the sanity for those mentioned responsibilities in the above. The software to be run on the server, developed on Microsoft Visual C++ 6.0, accepts TCP/IP based connection request from the remote device and processes received data to plot ECG of the patient carrying the mentioned remote device.

When this work had put the components together effectively to obtain fully functional system, it was shown that preference of mobility and IEEE 802.11b as the rapidly penetrating protocol for wireless communication protocol for an ECG data acquisition system is an efficient solution for tracking a patient's heart activity continuously in the context of economic and practicality concerns.

## 1.2 Motivation and Objectives

This project is a step towards reaching the ultimate goal of the complete fusion of healthcare and Internet at a hospital, home or anywhere in coverage area of a WLAN. There are numerous wireless communications protocols on the market for which an application such as ECG monitoring can be used. The below table shows a comparison of several available wireless protocols which can be used to in wireless ECG monitoring:

**Table 1.1**  
Comparison of several available wireless protocols [1, 2].

	Zigbee	Bluetooth	Home RF	802.11b
Frequency Band	2.4 GHz	2.4 GHz.	2.4 GHz	2.4 GHz
Stimulus peak in dB SPL right ear	250 Kbps	721 Kbps	1.6 Mbps	11 Mbps
Range	66 m	<10m	50 m	100 m

As it is seen, range of 802.11b for transmission and receive is greater than that of other protocols and that is why this protocol has been opted for communication between the remote device and the access point. One more cause for this choice is that 802.11b has the greatest data transmission rate, enabling addition of further applications for patient monitoring. The other remarkable benefit of selecting 802.11b protocol is that there is no charge has to be paid if the patient is in a coverage area of still existing WLAN.

Although this study attempts to track patient cardiac data, similar modified techniques could be used to communicate with patients and monitor other bodily variables like temperature, blood-sugar content, breathing patterns, weight, lipid levels, and much more.

In a nutshell, the objective of the study is to design a remote device which transmits smoothly amplified and appropriately filtered ECG signal via using IEEE 802.11b protocol. Besides, plotting of the cardiac signal is also proposed on the server side which is capable to accept unlimited number of connections from remote devices.

### **1.3 Thesis Outline**

This thesis work is composed of six chapters. The first chapter presents an introduction of electrical activity of heart and electrocardiogram with its usefulness in diagnosis. The second chapter presents detailed information of the developed client device hardware and firmware. The third chapter explains the design methods and functional description of the software which will on the server side of the system. The fourth chapter gives the assessment of the designed system and the considered future improvements which make the system more functional. The fifth chapter presents the conclusions provided by this study.

## 2. THE ELECTROCARDIOGRAM

### 2.1 The Electrical Activity of Heart

The parts of the heart normally beat in orderly sequence: Contraction of the atria (atrial systole) is followed by contraction of the ventricles (ventricular systole), and during diastole all four chambers are relaxed. The heartbeat originates in a specialized cardiac conduction system and spreads via this system to all parts of the myocardium. The structures that make up the conduction system are the sinoatrial node (SA node), the internodal atrial pathways, the atrioventricular node (AV node) the bundle of His and its branches, and the Purkinje system. The various parts of the conduction system

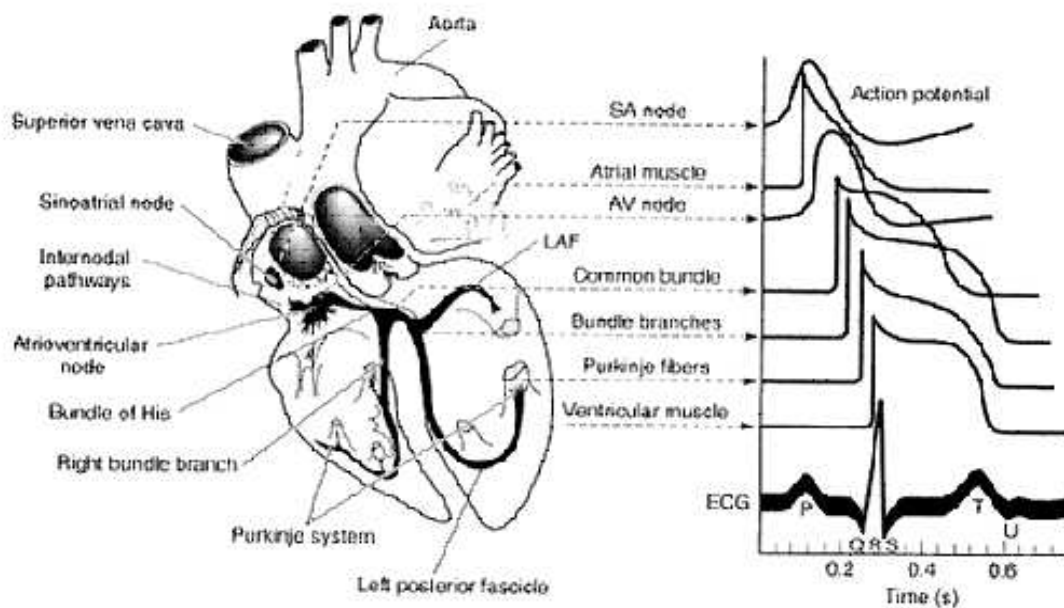

**Figure 2.1** Typical APs for the several nodes with the correlation to ECG [3].

and, under abnormal conditions, parts of the myocardium are capable of spontaneous discharge. However, the SA node normally discharges most rapidly, depolarization spreading from it to the other regions before they discharge spontaneously. The SA node is therefore the normal cardiac pacemaker, its rate of discharge determining the rate at which the heart beats. Impulses generated in the SA node pass through the

atrial pathways to the AV node, through this node to the bundle of His, and through the branches of the bundle of His via Purkinje system to the ventricular muscle [3].

## 2.2 The Waves and Usefulness of the ECG

The P wave is produced by atrial depolarization, the QRS complex by ventricular depolarization, and the ST segment and T wave by ventricular repolarization. The manifestations of the atrial repolarization are not normally seen because they are obscured by the QRS complex. The U wave is an inconstant finding, believed to be due to slow repolarization of the papillary muscles [4].

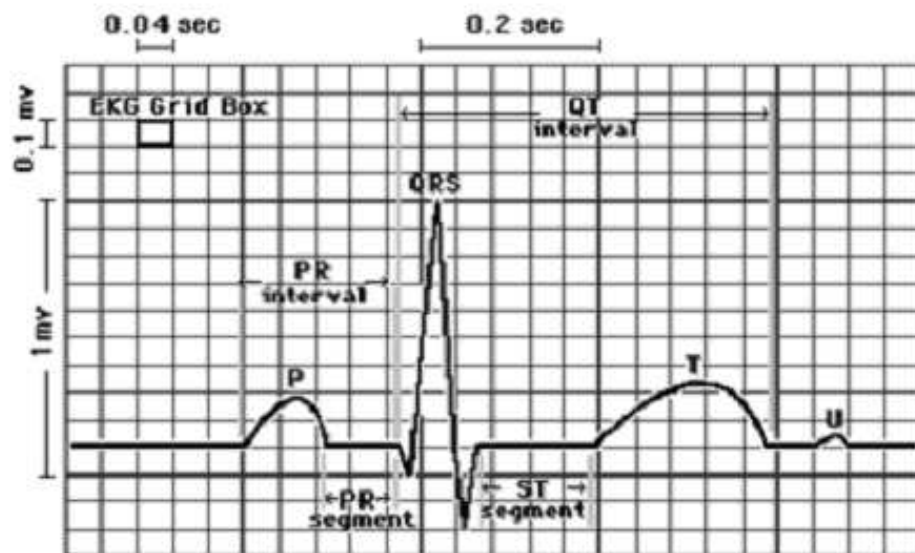
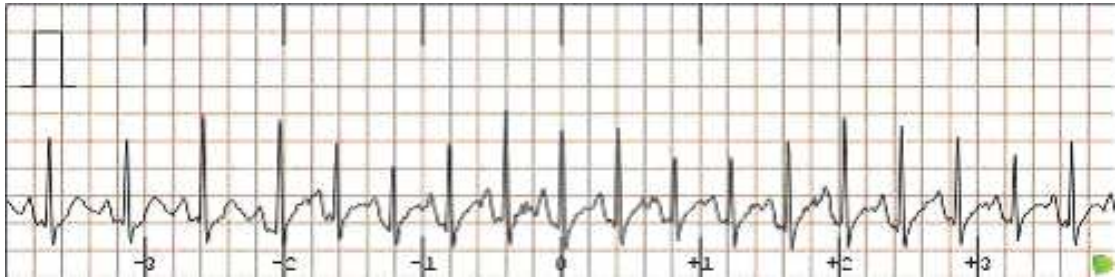

Figure 2.2 Waves of the ECG [3].

With advances in electrocardiography, the accuracy of electrocardiographic diagnosis has been greatly increased. Cardiac diseases such as atrial or ventricular arrhythmias, long QT syndrome, myocardial infarction and hyperkalemia can be diagnosed via investigation of the ECG.

Some examples of cardiac abnormalities diagnosed by ECG is also visible on

Figure 2.3 and Figure 2.4.



**Figure 2.3** Atrial tachycardia [3].

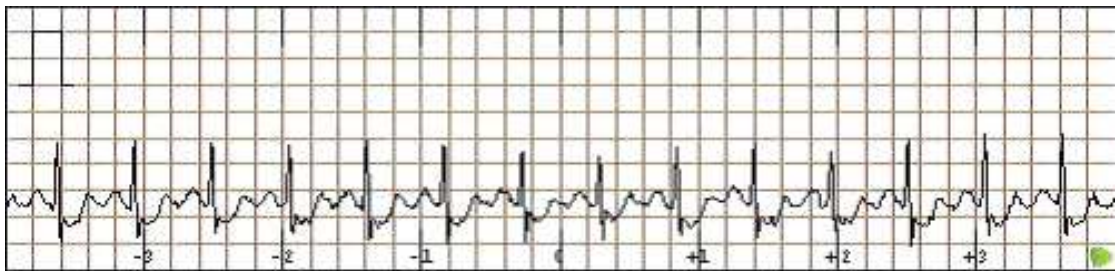

**Figure 2.4** Myocardial ischaemia (ST segment depression) [3].

### 3. THE CLIENT DEVICE DEVELOPMENT

#### 3.1 Hardware Design

##### 3.1.1 The Power Supply

The client device requires a stable and single voltage supply of nearly 3.3V which is obtained by a voltage regulator, LM2596-ADJ (3A Step Down Voltage Regulator) of National Semiconductor Co. An input

of 4.5V, at least, is enough for a stable output for this regulator as per the datasheet of LM2596-ADJ. The output voltage for the voltage regulator circuit is adjusted according to the specs mentioned in LM2596-ADJ's datasheet as well [5]:

$$V_{OUT} = V_{REF}(1 + R_1/R_2) \quad (3.1)$$

where  $V_{REF} = 1,23$ . Thus,  $V_{CC} = 3,44V$ .

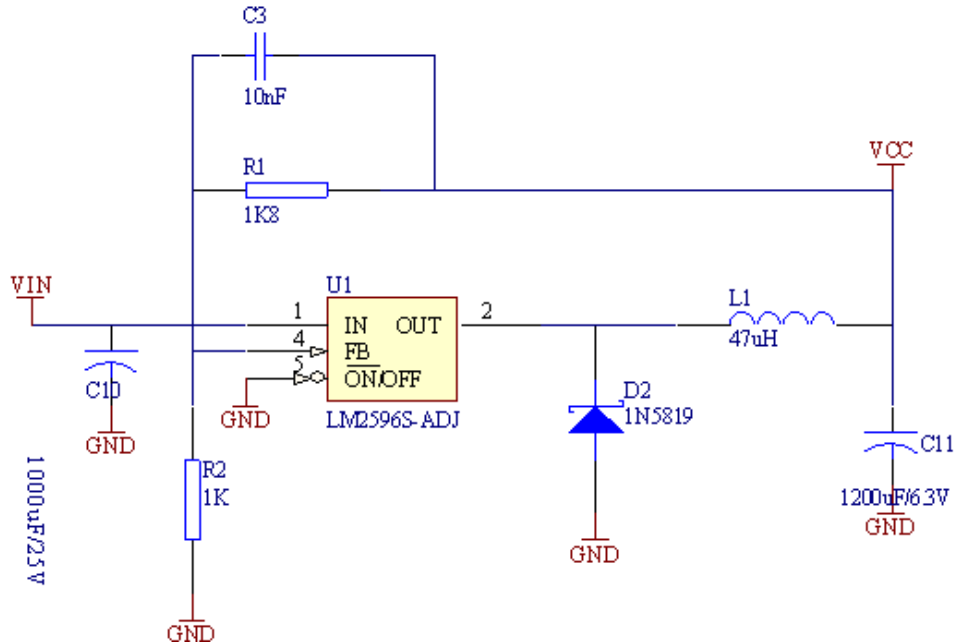

**Figure 3.1** The voltage regulation circuit.

Besides resistor values, other values of components such as inductor and capacitors are also determined according to the datasheet of voltage regulator IC. Moreover, a voltage divider circuit is simply developed to obtain a reference for ICs such as op-amps and instrumentation amplifier. Thus, the voltage for  $V_{GND}$  node is 1,72V in Figure 3.2.

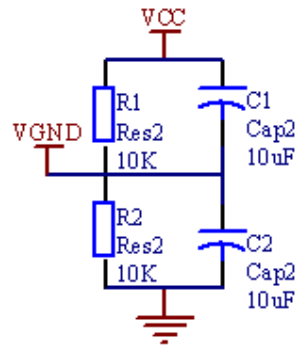

**Figure 3.2** The voltage divider circuit.

### 3.1.2 The ECG Amplifier and Filtering Network

**3.1.2.1 The Instrumentation Amplifier.** Precision - low power instrumentation amplifier, INA118 of Texas Instruments, is opted for the differential amplification

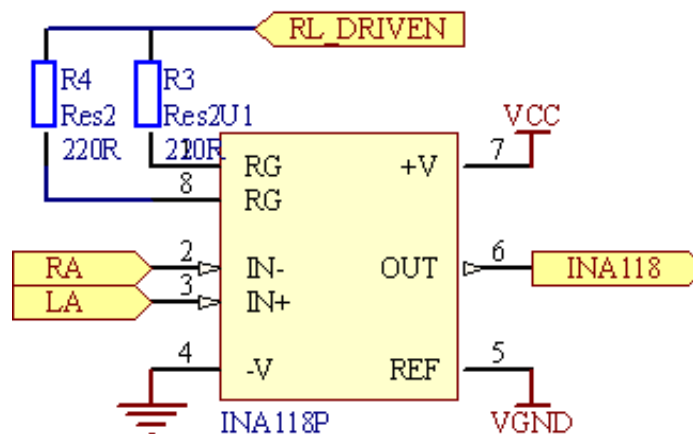

**Figure 3.3** Gain configuration of INA118.

of voltages on right and left arms. The INA118 is laser trimmed for very low offset

voltage (50mV), drift (0.5mV/°C) and high common-mode rejection (110dB at  $G = 1000$ ). It operates with power supplies as low as 2.7V, and quiescent current is only 350 microampere-ideal for battery operated systems [6].

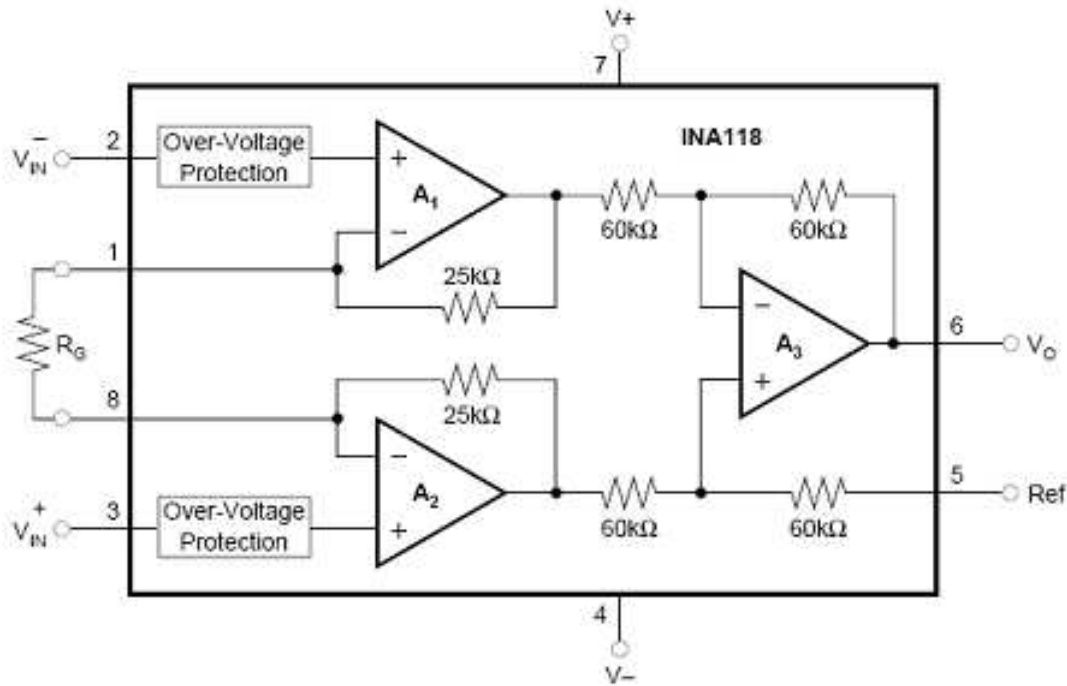

**Figure 3.4** The components overview of the INA118 [6].

The gain of  $G = 114,6$  is adjusted by resistors of 440 ohms according to the Equation 3.2:

$$G = (1 + 50K/R_G) \quad (3.2)$$

The differential mode gain ( $A_D$ ) of the instrumentation amplifier configuration is experimentally evaluated as 116,1 and the common mode gain ( $A_S$ ) is experienced as 0,00015. Hence, the common-mode-rejection-ratio of the configuration is evaluated as 117,7dB according to the Equation 3.3.

$$CMRR = 20\log(A_D/A_S) \quad (3.3)$$

What is more, the voltage for the noise of the IC for the specified configuration

is measured as nearly  $400nV_{rms}$ . Besides, noise bandwidth is:

$$BW_{noise} = BW_{signal} \cdot k \quad (3.4)$$

and  $k = 1.222$  where signal attenuation is 12dB/octave. Hence,  $BW_{noise} = 151.528$  since  $BW_{signal} = 124Hz$  due to the applied filters. As a consequence, noise is evaluated as  $32nV/\sqrt{Hz}$ .

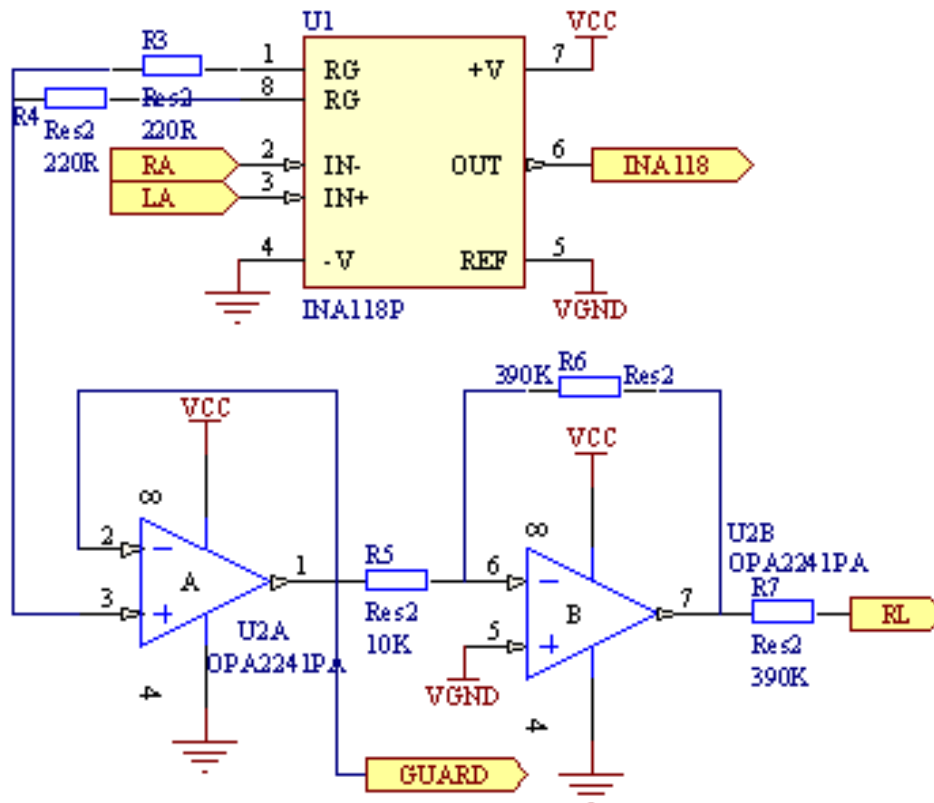
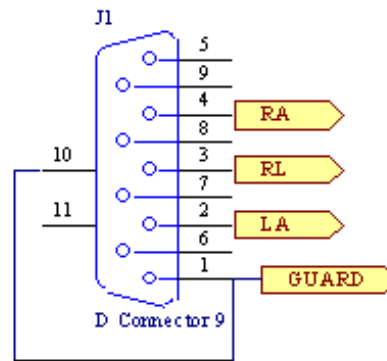

Figure 3.5 Guarding and driven right leg circuit.

Additionally, the guarding and driven-right leg circuit is also implemented as a feed back of common mode voltage. The OPA2241, dual version of OPA241 [7], is instrumented as the voltage follower opamp of guarding and inverting amplifier opamp for driven right leg circuit.

A DB-9 connector, implemented on the board, becomes useful for the junction of a shielded ECG electrode cable as shown in Figure 3.6.



**Figure 3.6** Connection configuration of the leads on DB9 connector.

**3.1.2.2 The Low-Pass Filter.** A 2<sup>nd</sup> order Sallen-Key active Butterworth unity gain low pass filter, including low-voltage-supply-requiring OPA2344PA [8], is integrated to the output of the INA118 to avoid frequency components, higher than 125 Hz, of received amplified signal and to yield a steep cutoff slope with a Q-factor of  $Q = 0,7071$ .

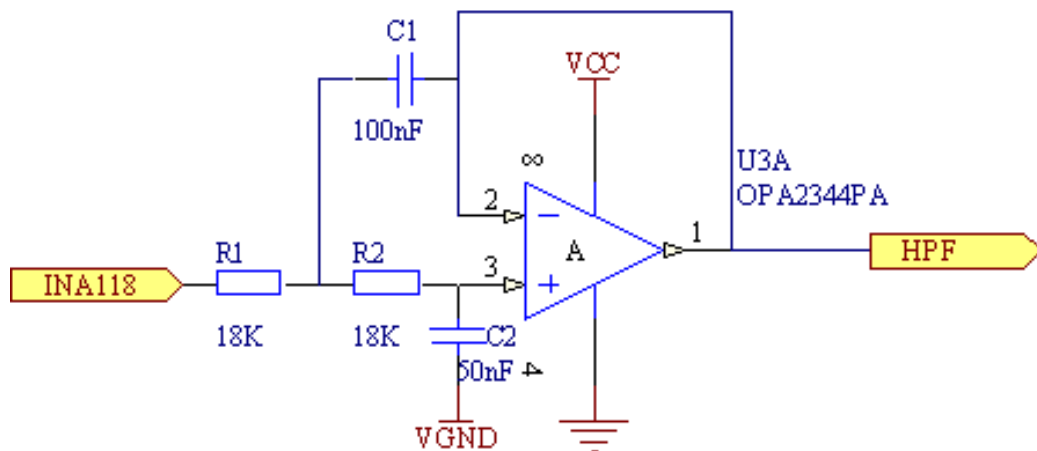

**Figure 3.7** The low-pass filter configuration.

The cut-off frequency ( $f_c$ ) is 125 Hz. where  $R = R_1 = R_2 = 18K$  and  $C = C_1 = 2 \cdot C_2 = 100nF$ . The practical cut-off frequency of the filter is measured as 124 Hz and the frequency response of the filter is determined and plotted as shown in the Figure 3.8.

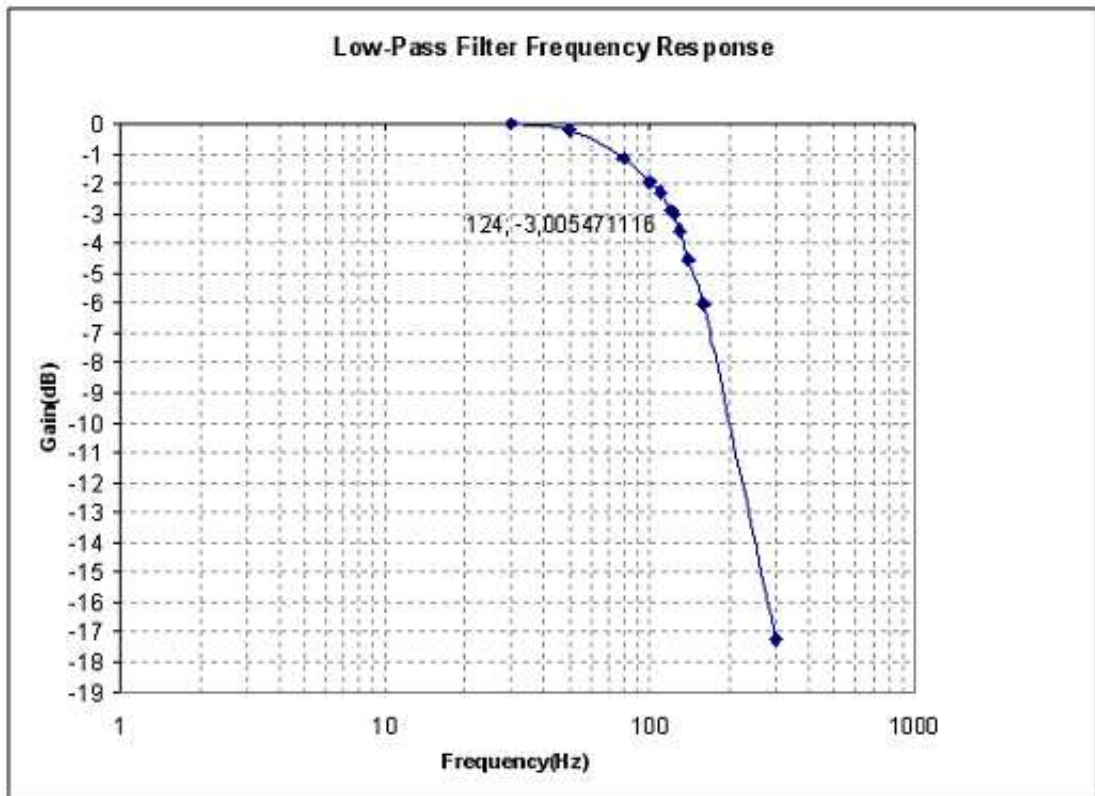
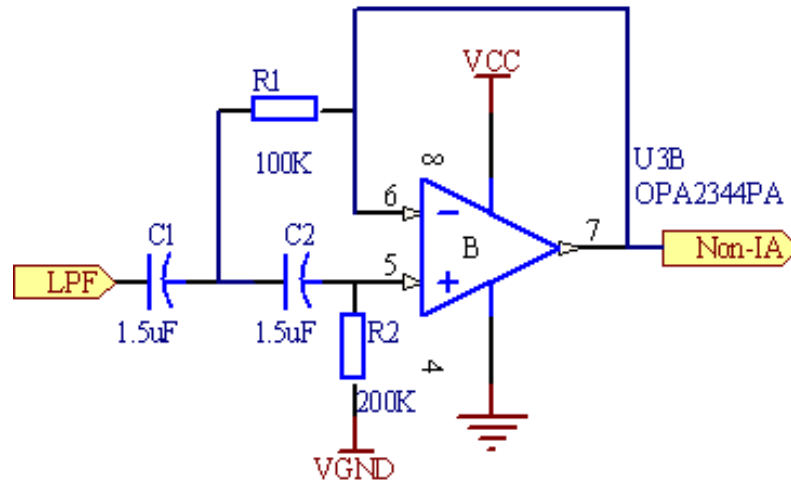

**Figure 3.8** Experimental frequency response of the low-pass filter.

**3.1.2.3 The High-Pass Filter.** The removal of any DC level introduced in the ECG amplifier circuit is a necessity, rather than a performance improvement. Since the frequency spectra for the ECG includes frequencies near 1 Hz it is important to not to attenuate these frequencies out of signal along with the DC component.

The frequency response of the Butterworth filter is maximally flat (has no ripples) in the passband, and rolls off towards zero in the stopband. When viewed on a logarithmic Bode plot, the response slopes off linearly towards negative infinity. For a first-order filter, the response rolls off at -6 dB per octave. For a second-order Butterworth filter, the response decreases at -12 dB per octave, a third-order at -18 dB, and so on.

Butterworth filters have a monotonically changing magnitude function with  $\omega$ . The Butterworth is the only filter that maintains this same shape for higher orders (but with a steeper decline in the stopband) whereas other varieties of filters (Bessel,



**Figure 3.9** The high-pass filter configuration.

Chebyshev, elliptic) have different shapes at higher orders.

The Sallen-Key topology uses active and passive components (op amps and capacitors) to implement a linear analog filter. Each Sallen-Key stage implements a conjugate pair of poles; the overall filter is implemented by cascading all stages in series. If there is a real pole (in the case where  $n$  is odd), this must be implemented separately, usually as an RC circuit, and cascaded with the op-amp stages.

Hence, A  $2^{nd}$  order Sallen-Key active Butterworth high pass filter with a unity gain, cutoff frequency of 0,75 Hz and Q-factor of 0,7071 is implemented to remove the DC and low frequency components, becoming more noteworthy while the device is mobile, of the signal received from the output of low pass filter. The cut-off frequency of the high pass filter is measured as 0,74 Hz and frequency response is determined experimentally as it is illustrated in the Figure 3.10.

Digital implementations of Butterworth filters often use bilinear transform or matched z-transform to discretize an analog filter. For higher orders, they are sensitive to quantization errors. Thus, as a further improvement of the client device, it should be considered to implement a digital filter since the microcontroller involved in the equipment has resources to comply digital filtering process.

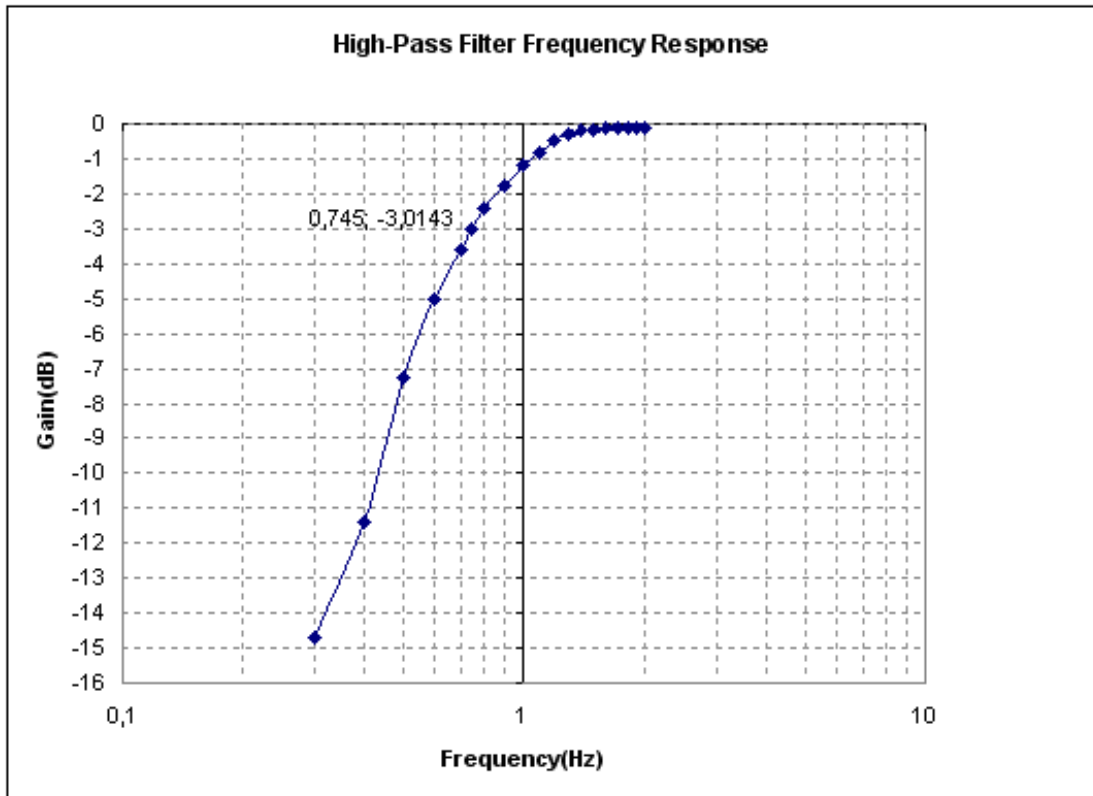

Figure 3.10 Experimental frequency response of the high-pass filter.

**3.1.2.4 The Non-Inverting Amplifier.** A non-inverting amplifier with the gain of nearly  $G = 23$ , evaluated according to the peak voltage of amplified ECG signal (R wave) of high pass filter circuit output, is applied to amplify that of notch filter input up to nearly 3,2V. Thus, a superior efficiency of resolution for ADC of the microcontroller is obtained.

$$V_{OUT} = V_{IN} \left( 1 + \frac{R_2}{R_1} \right) \quad (3.5)$$

What is more, an inverting amplifier with the same gain can also be implement to amplify the signal. On the other hand, a software enhancement is required to invert this initially inverted signal.

Besides, the gain of the amplifier stage can be adjustable according to the patients whose cardiac signal amplitude alters as to the some bodily variables.

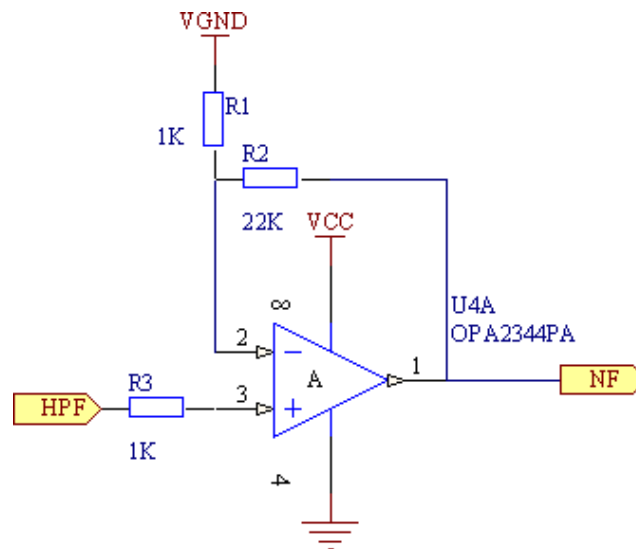
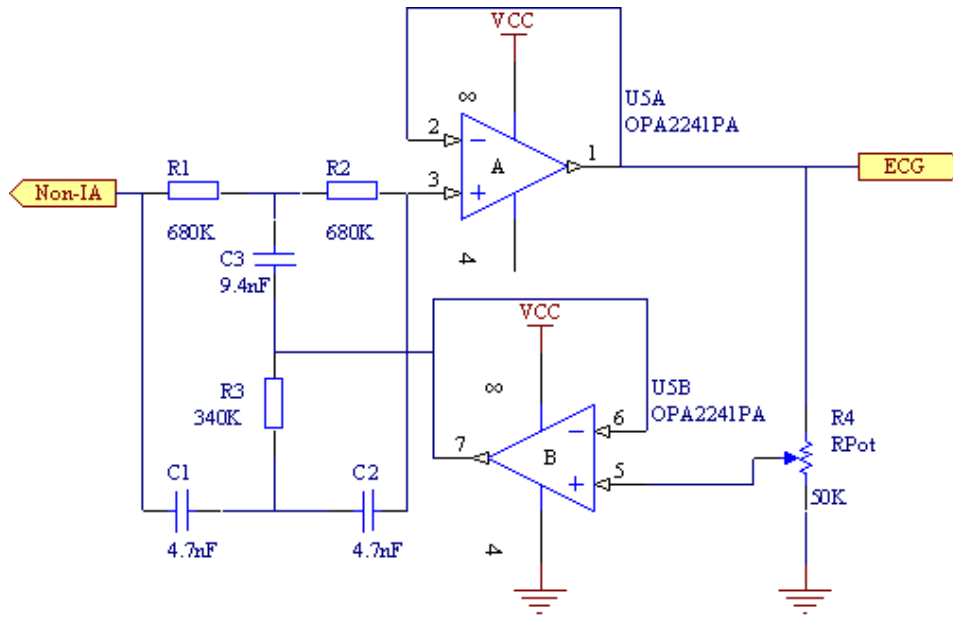

**Figure 3.11** Non-inverting amplifier configuration.

**3.1.2.5 The Notch Filter.** A notch filter application is performed to avoid unwanted 50 Hz frequency components of the signal from output of non-inverting amplifier since the noise of electricity network dominates the 50 Hz frequency components of ECG signal of the body. What is more, due to implementation of notch filter not only 50 Hz frequency components of the signal are avoided but also near frequency components are attenuated in accordance with Q-Factor of the filter which is adjusted by the potentiometer illustrated in Figure 3.12.

The trade off occurs that while the Q-Factor increasing, the depth of the notch decreases. Thus, the potentiometer remained on the board, instead of use of static resistor values, to enable the adjustability of filtering according to the environment where patient stays.

An interesting change in the high Q - twin "T" occurs when components are not exactly matched in ratio. For example, an increase of 1 to 10 percent in the value of  $C_3$  will raise the Q, while degrading the depth of the notch. If the value of  $C_3$  is raised by 10 to 20 percent, the network provides voltage gain and acts as a tuned amplifier. A voltage gain of 400 was obtained during testing. Further increases in  $C_3$  cause the circuit to oscillate, giving a clipped sine wave output [9].



**Figure 3.12** The notch filter configuration.

The circuit is easy to use and only a few items need be considered for proper operation. To minimize notch frequency shift with temperature, silver mica, or polycarbonate, capacitors should be used with precision resistors. Notch depth depends on component match, therefore, 0.1 percent resistors and 1 percent capacitors are suggested to minimize the trimming needed for a 60 dB notch [9].

In this study, the central frequency for the notch filter is evaluated as 49.8 and observed experimentally as 49.6. The frequency response of the mentioned filter illustrated in Figure 3.13.

$$f_c = \frac{1}{2\pi RC} \quad (3.6)$$

where  $R = R_{1,2} = 2R_3 = 680K$  and  $C = C_{1,2} = C_3/2 = 4.7nF$ .

Since the Q-factor for the notch filter is the ratio between the bandwidth of the notch and the center frequency, and when the resistor values for the potentiometer in Figure 3.12 are 20,6K (between the output and the input for the feedback) and 27,8K (between the input for feedback and ground), the Q factor is evaluated as 0.67.

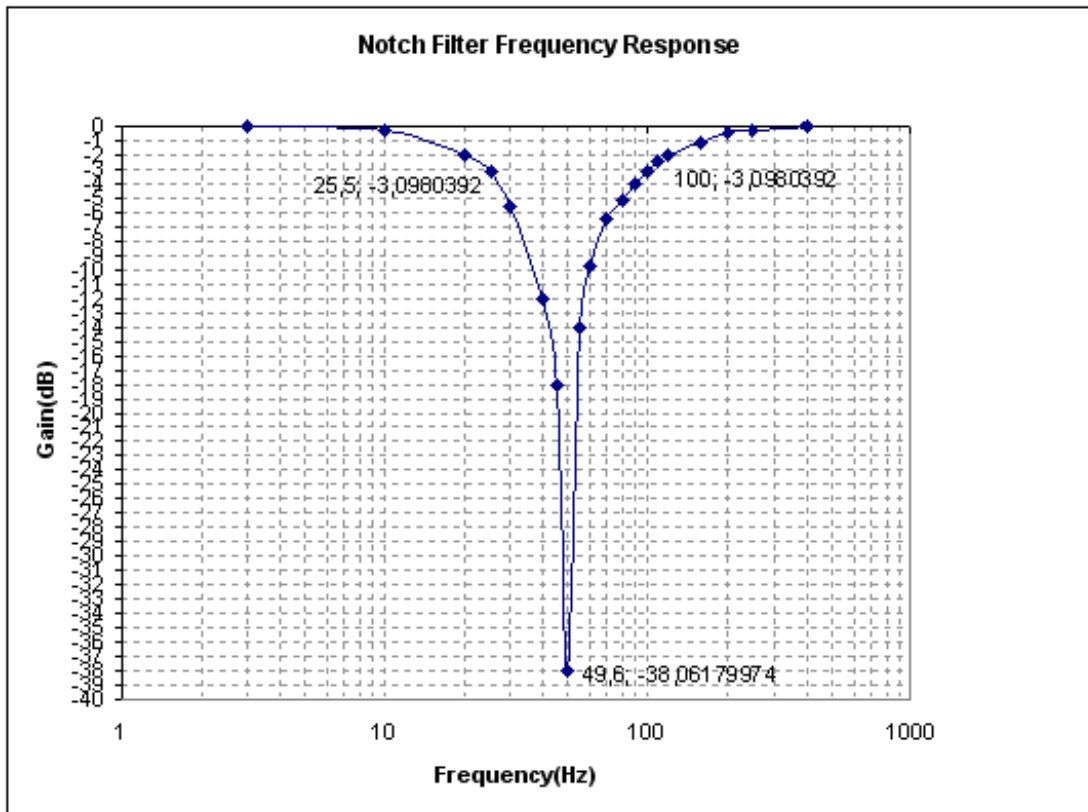

**Figure 3.13** Experimental frequency response of the notch filter.

### 3.1.3 The Microcontroller Unit

Microchip's 8-bit PIC18LF4520, running the developed firmware with a 20 MHz clock frequency and at low voltage level of 3.3V, is mounted on the system to perform time critical 8-bit analog to digital conversion and communication with embedded wireless module via UART [10].

PIC18LF4520, implements a 32 KB flash-type program memory, 1536 bytes of RAM, hardware UART and yields up to 100K samples/s of A/D conversion [10], satisfies the mentioned project requirements.

Receive interrupt as the external one, and the timer and ADC interrupts as the internal ones make it available to evaluate data received from the wireless module and carry out time critical process of analog to digital conversion.

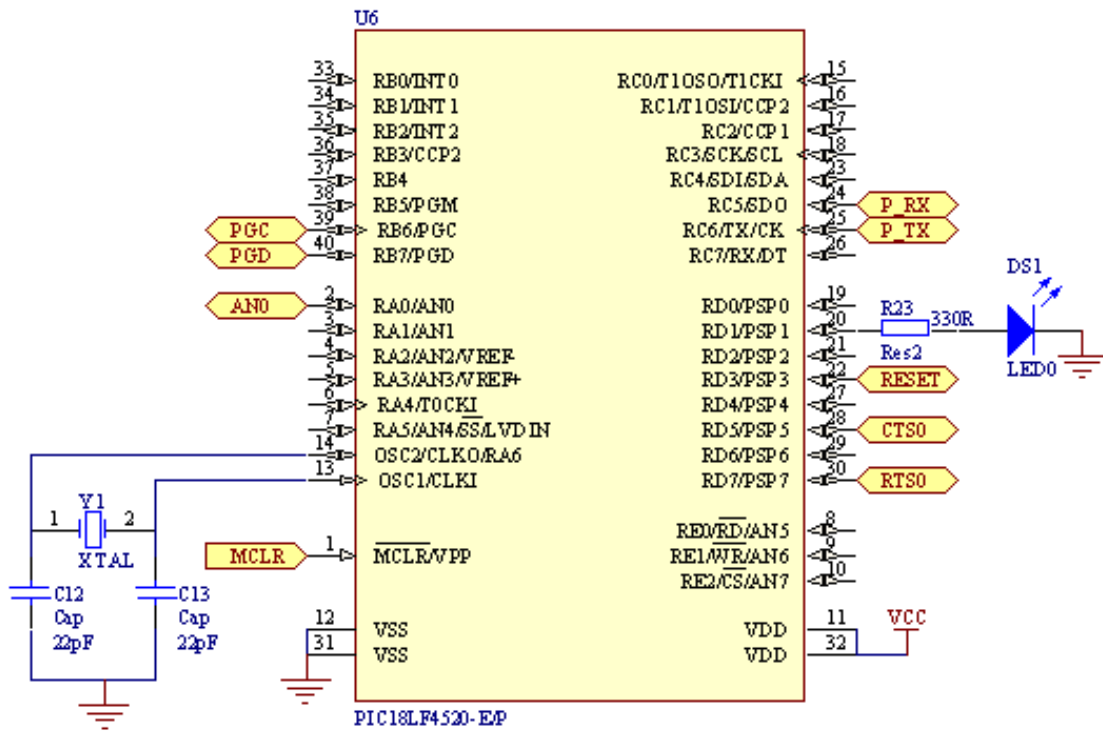

Figure 3.14 The PIC18LF4520 and its configuration.

What is more, a connector to the PGC-PGD and MCLR pins of MCU is placed on the board in the aim of processing the debugging issues of the firmware via Microchip's ICD 2 In-Circuit-Debugger.

### 3.1.4 The Embedded Wireless Networking Device

Wireless embedded device server, WiPort of Lantronix Co., is integrated to add IEEE 802.11b wireless networking in a range of 100m indoors to the developed remote device with the serial interface and WEP/WPA capabilities. To enable access to a local network or the Internet, the WiPort integrates a fully developed TCP/IP network stack and OS. Due to using the TCP/IP, the device assures that no data is lost or duplicated and that everything sent to the connection arrives correctly at the target. The WiPort also includes an embedded web server that can be used to remotely configure, monitor, or troubleshoot the attached device [11].

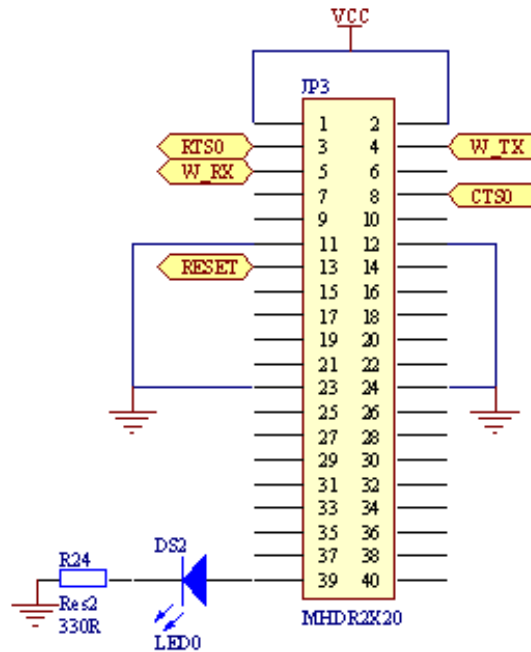

Figure 3.15 The WiPort connector.

The WiPort uses the widely accepted 802.11b protocol to connect to a wireless infrastructure or ad-hoc network, and uses the Transmission Control Protocol (TCP) to assure data transmission rate of up to 11Mbps. Even though this transmission rate is very high for the application in this study, it enables further developed features' data transmission optionalities for other bodily variables.

As the electrical spec, the WiPort operates on a single 3.3V supply, and has a built-in voltage supervisory circuit [11].

The WiPort, weighting 29 grams [11], is mounted on the remote device board with a 40-pin connector to provide power supply and serial communication with MCU.

## 3.2 Firmware Design

After preparation of the hardware for the remote device, firmware of the PIC18LF4520 was developed via utilizing Microchip's MPLAB C18 Compiler which is a full-featured

ANSI compliant C compiler for the PIC18 family of PICmicro® 8-bit MCUs. Moreover, MPLAB C18 is a 32-bit Windows® console application as well as a fully integrated component of Microchip's MPLAB Integrated Development Environment (IDE), allowing source level debugging with MPLAB's software and hardware debug engine, called MPLAB ICD2 [12]. This In-Circuit-Debugger (ICD2) also became significantly useful for debugging and programming processes of the firmware.

Initialization of interrupts and some several configurations for the MCU are completed on start-up of MCU. Two-level interrupt priority of MCU is enabled that analog to digital conversion and timer interrupts have the high priority while receive(of UART) interrupt is having the low priority to provide exact timing of analog to digital conversion.

### **3.2.1 Timer Implementation**

Timer interrupt of MCU is used to carry out the one-millisecond periods for analog to digital conversion. Thus, 1000 samples per second for amplified and filtered analog cardiac signal is provided. Furthermore, each obtained four samples were summed and divided by four, hence 250 samples are transmitted to wireless networking device to be forwarded to the server. Since the bandwidth of the signal is 0,75-125 Hz, 1000 samples per second is enough for a need of further reconstruction of the signal.

### **3.2.2 ADC Conversion Program Implementation**

One ADC port of MCU is used and configured to perform ADC processes. The ADC interrupt of MCU is also configured to immediately process the sampled signal. As every ADC is started during timer interrupt handling, 1000 ADC is realized in each second.

### 3.2.3 UART Configuration and Utilization

Serial communication between the MCU and WiPort is actually carried at 115200 bps while data transmission to server, it is adjusted to 9600 bps, default baud rate of the wireless networking device on boot-up, to gather MAC address of WiPort during initialization of client device. This retrieved MAC address will be a necessary in acceptance of client device's connection to server which holds the registered patients identity and the matched client device's MAC address. The sent MAC address after connection to the server socket will be the identifier for the patient who carries the relating device which is registered to his/her name.

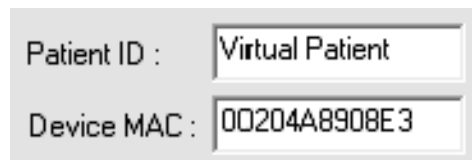

**Figure 3.16** A snapshot of patient - client device MAC address registration.

When the server accepts the connection request from any device, it notifies the remote device with an acknowledgment code, "O" (letter). On the other hand, if the server software cannot retrieve the required MAC address in five seconds due to any cause, the connection request is rejected and the socket, created for this connection, is destructed to prevent system from being congested due to redundant connections.

### 3.2.4 Configuration and Utilization of Embedded Wireless Module

The embedded wireless module, WiPort directly transmits the data received from UART to the specified IP address determined via web-based configuration of the device. Besides, during boot-up of the WiPort, received "xxx" string leads the device to enter configuration mode. As the MCU is responsible for sending mentioned string to the WiPort's RX port, the MAC address of the WiPort is automatically transmitted through TX port while entering configuration mode. Therefore, the MCU retrieves and registers the device's MAC address as the patient's unique ID.

In addition to providing MAC address, WiPort presents its connection status to the adjusted IP address of the server as well. When the connection appears, the WiPort transmits a "C" letter and when the connection is closed or lost a "D" or "N" letter is transmitted. Hence, the MCU is capable to determine the connection status of the WiPort to the server socket in the aim of availability of transmitting the cardiac data to the WiPort.

## 4. SOFTWARE DEVELOPMENT FOR THE SERVER

The software, Central ECG Monitor, is developed to perform the communication procedures with the theoretically unlimited number of remote devices and monitor the received ECG data from the currently selected relating patient.

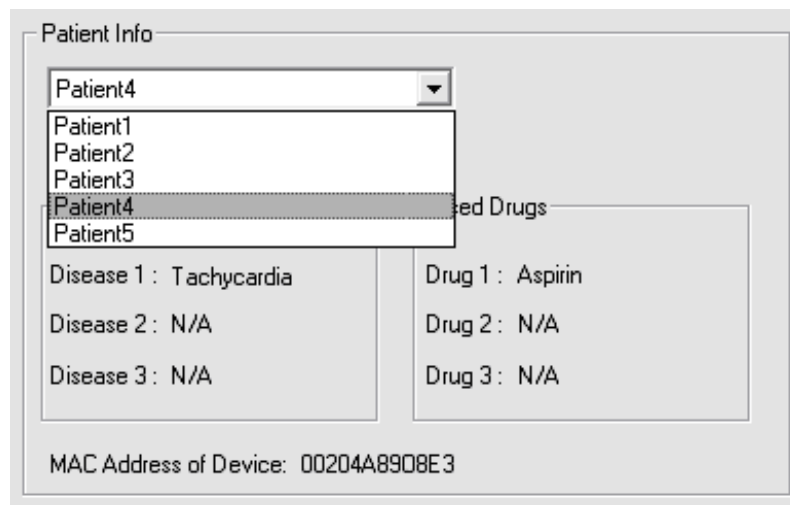
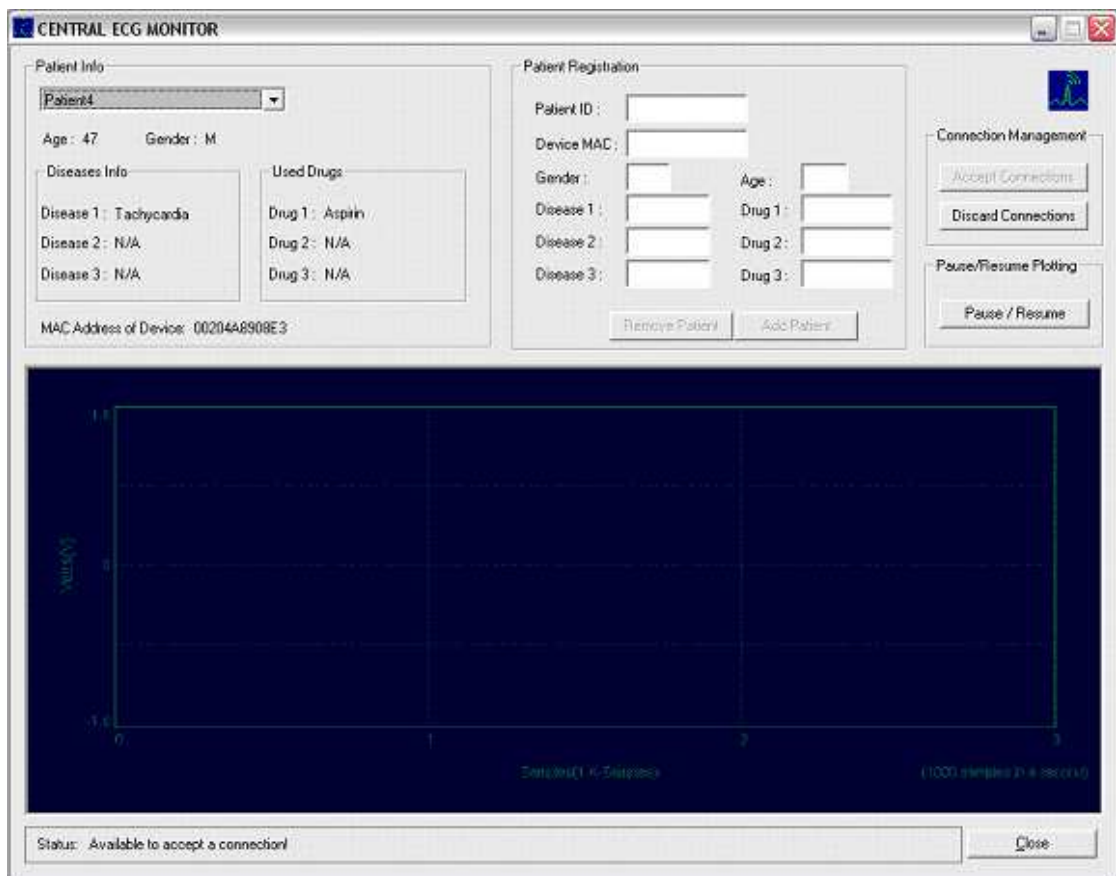

**Figure 4.1** A snapshot while selecting patient from the drop-down list.

Central ECG Monitor, coded and designed on Microsoft Visual C++ v6.0 with the significant aid of Microsoft Foundation Classes Library,

- creates listening TCP socket on Port 4000,
- accepts valid connection requests,
- creates new sockets for the appropriately accepted connections,
- receives data from the accepted connections,
- plots the last 3 seconds of the received ECG data of the selected patient from the drop-down list on the interface of the program and each pixel represents the average value of four consecutive samples of the ECG,
- is capable to discard all connections,

- enables to pause/resume plotting of the electrocardiogram for a while,
- holds age, gender, drug and disease info of the selected patient on the drop-down list,
- shows the most current connection status of server,
- registers new patients or removes them from the registers.



**Figure 4.2** The Central ECG Monitor software.

This software can be run on a bed side monitor to monitor a patient's cardiac data in the coverage of a WLAN such as an intensive care unit and an ambulance having a WLAN access point besides running on a central server collecting data from lots of client devices.

Figure 4.3 illustrates a brief overview of the interaction between client devices and the server.

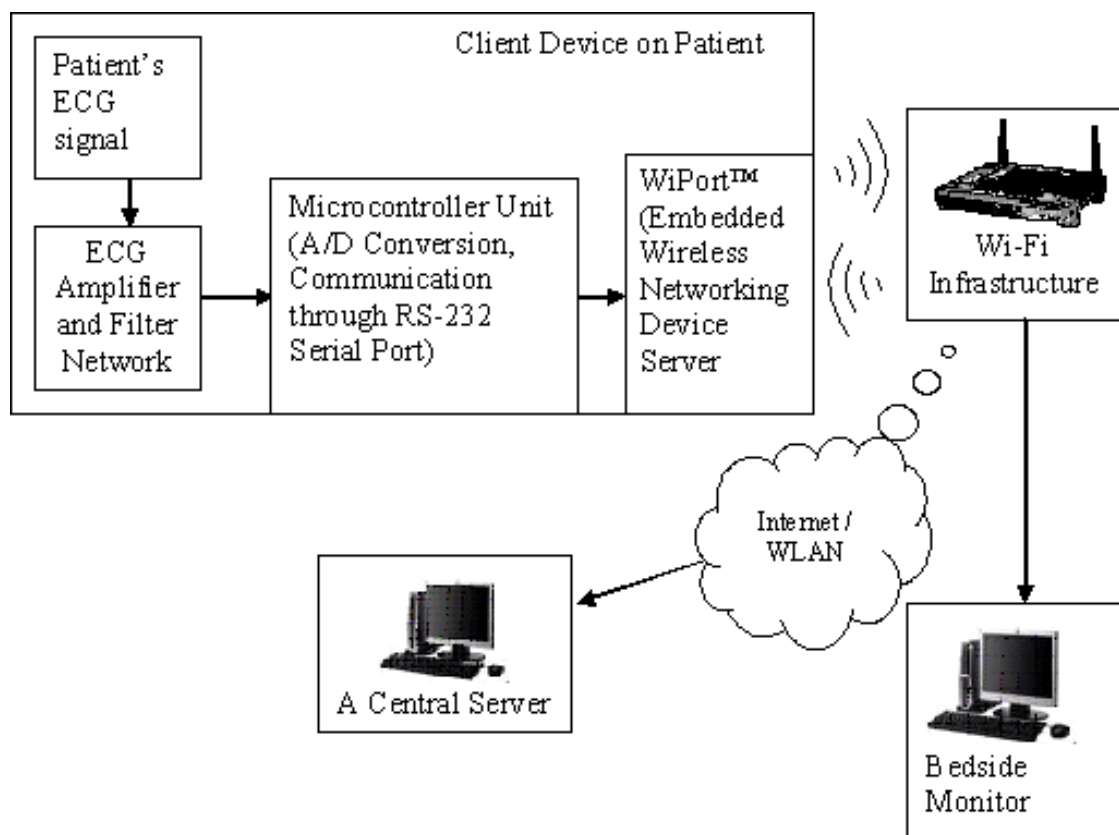

**Figure 4.3** An overview of the overall system architecture.

## **5. SYSTEM ASSESSMENT AND FURTHER IMPROVEMENTS**

### **5.1 Signal Quality at the Output of Amplifier and Filtering Network**

The smooth signal that is avoided from noises at the output of amplifier and filtering network provides practicality in diagnosis so that the system is strongly believed to be a reliable instrument in intensive care units or monitoring of ambulatory patients' cardiac activity. Furthermore, any further improvements in the system with implementation of ECG signal analysis algorithms become available due to this clear obtained ECG signal. What is more, although generally 40 Hz bandwidth for ECG signal is preferred for Holter devices and 30 Hz bandwidth is used for ECG monitoring applications, 125 Hz bandwidth is opted for ECG signal handling in this study.

### **5.2 Sampling Rate for ADC**

High sampling rate of 1000 samples per second, as another leg of obtaining robust signal representation, and evaluation and taking into account of every four samples' average removes the artifacts in ADC of MCU. What is more, sampling rate also satisfies the requirements for enabling reconstruction of the signal.

### **5.3 Power Consumption and Implementation of External SDD or RAM**

Option of low voltage and low power instruments such as opamps and instrumentation amplifier enhances low power dissipation property of the client device as well

as providing the client device operation (with a voltage of 3.3V) with a single supply and the removing the requirement of another dedicated voltage regulation circuit for the wireless networking device operating with a voltage of 3.3V. Thus, single type of batteries become suitable for the client device and causes the betterment in means of size of the whole device. On the other hand, the continuous transmission of ECG data currently causes high power consumption due to the embedded wireless networking module's high power requirement (300 mW [11]) for providing connection stability to the server. As a consequence of a further improvement with implementation of a solid state disk or external RAM, the ECG data can be buffered for a period of time, which can be laterly considered for optimization, and transmitted to the target server when this adjusted time is run out. Thus, the necessity of wireless networking device to be continuously connected to the server will disappear.

Due to MCU's functional interfacing capabilities such as SPI and I2C, the mentioned external memory or SSD can be easily implemented in the system via some little modifications in firmware and PCB layout.

Furthermore, the implementation of those external memories make the client device store the ECG data when the server is unreachable due to any problem such as becoming out of the coverage area or any situation of becoming down of the WLAN access point or the server. As a consequence, no data loss that enhances the system reliability about prevention of data loss will occur be provided.

## **5.4 The Software on the Server**

The Central ECG Monitor, the software utilized on the central server, smoothly plots the retrieved cardiac signal from the selected patient. Therefore, the plotted signal quality satisfies the diagnosis and analysis processes. The waveforms of ECG namely P wave, QRS complex and T wave are able to be simply realized by ocular inspection of the medical specialist.



**Figure 5.1** Plotted ECG when the electrodes placed on the limbs.

Furthermore, the software running on the server is able to accept unlimited number of connections and registration of patients. While the "accepting of connections" functionality of the software is enabled by the user, the selection of a patient from the list results in the plotting of the received data for the specified patient unless the connection to the relating client device is lost.

Besides plotting the received data, the software also hold several information about the patients such as disease, age, medication etc. Thus, the medical specialist not only views the patient's cardiac activity but also accesses to the general info with respect to the specified patient.

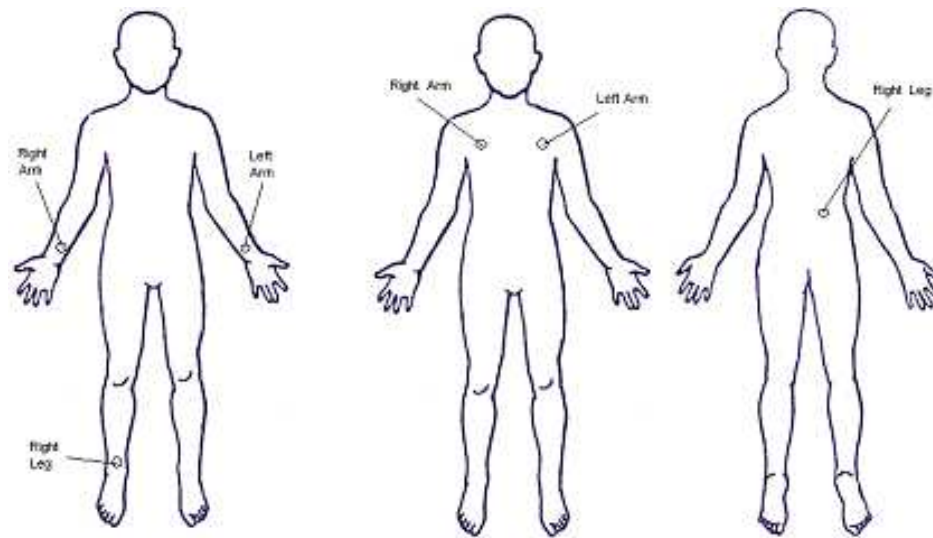

**Figure 5.2** Electrode connection diagrams on the limbs and the chest.



**Figure 5.3** Plotted ECG when the electrodes placed on the chest and back.

## 5.5 Computerized ECG Signal Analysis and Diagnosis

Automatic detection of any problematic activity of heart that may be a further upgrading of the system and simultaneously generation of alarm during those emergency situations reduces the workload of the medical specialist. To achieve this, some algorithms [13] such as detection of QRS complex, tachycardia, atrial fibrillation, heart rate etc. has been developed and implemented to the software or firmware of some applications. Those may be embedded on the MCU which is estimated to support required DSP with its 8x8(bits) hardware multiplier with the performance of a 8x8 unsigned integer multiplication in 200 ns [10], or implemented the Central ECG Monitor which is to be verified according to the number of simultaneous connected client devices.

## 5.6 Conformity of Amplifier and Filtering Network to the European Standards

The tests, currently not realized within this study, for the conformity to the European Standard EN 60601-2-27:2006 may be a part of future improvements of the system. Moreover, providing of a smooth ECG signal actually makes sense about the compatibility of the system to the mentioned standard. The standards which may apply to this system for the accuracy of operating data collected under heading "Essential Performance" of the mentioned document bring expressions that:

- Accuracy of signal reproduction: Input signals in the range of 5 mV, varying at a rate to 125 mV/s, shall be reproduced on the output with an error of 20 % of the nominal value of the output or 0,1 mV, whichever is greater.
- Input dynamic range and differential offset voltage: With a d.c. offset voltage in the range of 300 mV and differential input signal voltages of 5 mV that vary at rates up to 320 mV/s, when applied to any lead wire, the time-varying output

signal amplitude shall not change by more than 10 % over the specified range of d.c. offset.

- Input impedance: The input impedance shall be at least  $2,5M\Omega$  within a d.c. offset voltage range of  $\pm 300mV$ .
- Input noise: The signal noise caused by the ECG amplifier and patient cable shall not exceed  $30\mu V$  peak-to-valley referred to the input (RTI). Any mains frequency notch filter, if provided, is to be turned on during this test.
- Gain control and stability: Equipment shall provide at least one gain setting no lower than 5 mm/mV. Equipment having permanent display capabilities (recorder, printer) shall provide at least one fixed gain setting of 10 mm/mV. In addition, continuously variable gain control may be provided, if this mode is clearly indicated on the display and, if provided, on the recorded output.
- Time base: For all permanent displays there shall be at least one time base of 25 mm/s with an accuracy within  $\pm 10\%$ . For equipment with non-permanent displays, the available time bases shall be disclosed. The time base accuracy for any settings shall not vary by more than  $\pm 10\%$  over the complete horizontal channel width.
- Frequency response: The equipment shall meet the requirement for a frequency response (bandwidth) of at least 0,67 Hz to 40 Hz when tested with two types of input signals as described with methods A and B. For Method A, the output at 0,67 Hz and 40 Hz shall be within 71 % to 110 % of the output obtained with a 5 Hz sine wave input signal. For Method B, the output response obtained with the waveform of the below figure with a 20 ms base width must be within 75 % to 100 % of the output obtained with a base width of 200 ms.
- Impulse response: Equipment providing a low-frequency response less than 0,67 Hz shall not produce a displacement greater than 0,1 mV, nor a slope exceeding 0,3 mV/s following the end of the impulse when an input impulse of 0,3 mVs (3 mV for 100 ms) is applied. If ECG signals are recorded with this extended

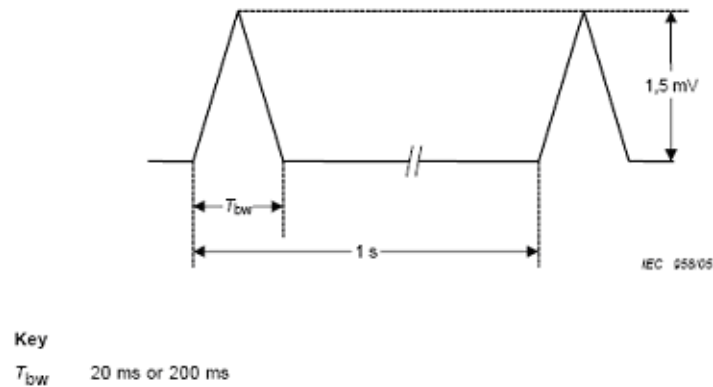

**Figure 5.4** High frequency response for the equipment.

low-frequency response, an indication of the extended low corner frequency shall appear on the recording medium.

- Calibration voltage: A calibration voltage shall be provided having a value and form that produces a step change in display output whose amplitude is within  $\pm 10\%$  of the step change amplitude obtained by applying a  $1\text{mV} \pm 0,01\text{mV}$  signal at the appropriate lead. It shall have a rise time of less than 10 ms and a decay time constant of at least 100 s. It shall be available in all positions of the lead selector. Equipment providing only one fixed gain and equipment which always provide a displayed gain indication for each waveform in all permanent and non-permanent displays are exempt from the requirement to provide a standardizing voltage.
- Common mode rejection: A 10 V r.m.s. signal at mains frequency (50 Hz/60 Hz) with 200 pF source capacitance, connected between earth and all lead wires connected together shall not produce an output signal greater than 10 mm peak-to-valley at a sensitivity of 10 mm/mV over a 60 s period. In series with each electrode shall be a  $51\text{k}\Omega$  resistor in parallel with a 47 nF capacitor. The patient cable specified by the manufacturer shall be used.
- Baseline reset: Means shall be provided for restoring the equipment to its normal operating condition within 3 s after applying a 1 V peak-to-valley 50/60 Hz overload voltage for at least 1 s.

## 6. CONCLUSION

With this study, it is proven that IEEE 802.11b protocol with TCP which enables reliability in wireless communication is feasible and efficient in ECG data acquisition systems and providing the tracking of most current cardiac data of ambulatory patients. Moreover, computerized analysis and alarm producing which can be further integrated to the client device or the server application program enhances the system to provide benefits to the medical specialist in means of becoming alerted about the lots of patients' cardiac abnormalities. Although system has a drawback in the context of data loss during a disconnection between the server and the client, addition of a solid state disk or an external memory on client device and implementing a database on the server side can remove the probability of data loss with the aid of initially obtained reliability of IEEE 802.11b and TCP/IP.

Operation of the client device with a single power supply (with a voltage level of nearly 3.3V) which simplifies the mobility of the device with a single battery minimizes the device in size and yields a cost reduction due to removing the requirement of an extra voltage regulation circuit or separate batteries for the wireless networking module and the amplifier -filtering network.

Amplifier and filtering network which can be recommended in later applications of ECG signal processing or evaluation due to its producing pretty smooth signal property would be tested for the conformity to the European Standard EN 60601-2-27:2006, "Particular requirements for the safety, including essential performance, of electrocardiographic monitoring equipment" to assure the quality of the acquired and the plotted signal by the Central ECG Monitor, run on the server side.



### APPENDIX B. SCHEMATIC FOR THE CLIENT DEVICE

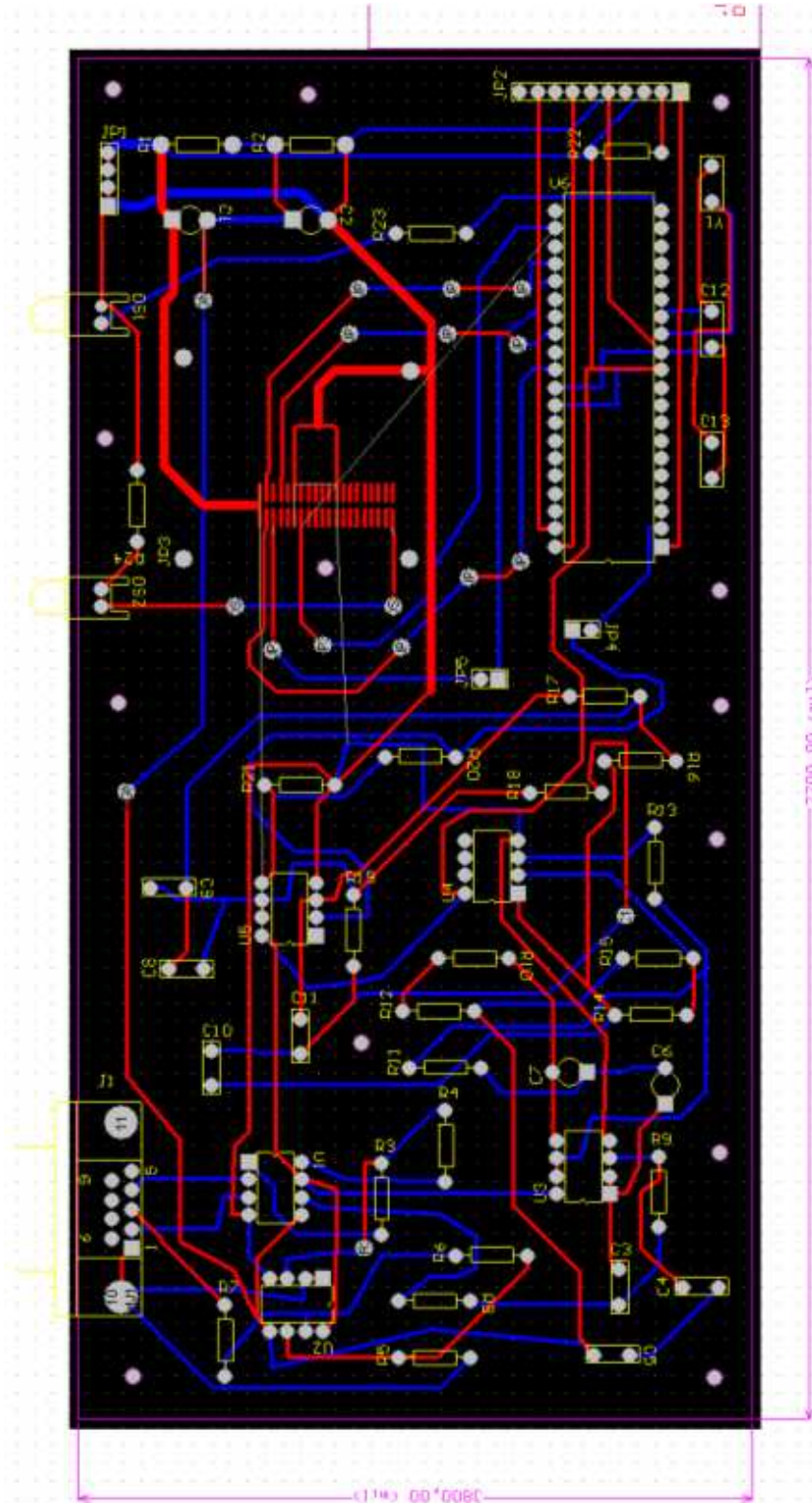

Figure B.1 PCB Layout for the client device.

## **APPENDIX C. FIRMWARE OF CLIENT DEVICE AND SOFTWARE FOR SERVER**

All appended source code is founded on attached CD-ROM.

## REFERENCES

1. Gast, M., *802.11 Wireless Networks: The Definitive Guide*, Sebastopol: O'Reilly, 2005.
2. Bary, J., and F. Charles, *Bluetooth: Connect Without Cables*, N.J.: Prentice Hall, 2001.
3. Gannong, W., *Review of Medical Physiology*, New York: McGraw Hill, 21st ed., 2003.
4. Goldman, M., *Principals of Clinical Electrocardiography*, California: Lange Medical Publications, 1973.
5. *LM2596 3A Step-Down Voltage Regulator Datasheet*, National Semiconductor, 2002.
6. *INA118 Precision Low Power Instrumentation Amplifier Datasheet*, Burr-Brown Co., 1998.
7. *OPA2241 Single Supply Micro Power Operational Amplifier Datasheet*, Burr-Brown Co., 1998.
8. *OPA2344 Single Supply Rail to Rail Operational Amplifier Datasheet*, Burr-Brown Co., 2001.
9. *High Q Notch Filter Linear Brief*, National Semiconductor Co., 1969.
10. *PIC18F2420/2520/4420/4520 Datasheet*, Microchip Technology Co., 2004.
11. *WiPort Datasheet*, Lantronix Co., 2006.
12. *MPLAB - CXX Compiler User's Guide*, Microchip Technology Co., 2000.
13. Malarvili, M. B., S. Hussain, and A. A. Rahman, "Development of automated 12-lead qt dispersion algorithm for sudden cardiac death," *The Internet Journal of Medical Technology*, Vol. 2, no. 2, 2005.
14. Lee, E. A., and D. G. Messeschmitt, *Digital Communication*, Boston: Kluwer Academic Publishers, 1994.