

FOR REFERENCE

NOT TO BE TAKEN FROM THIS ROOM



**PHOTOCHEMICAL STERILIZATION
OF *ESCHERICHIA COLI*
IN DRINKING WATER**

by

KLODYA VERT ARAZ

B.S. in Chem. Eng., Boğaziçi University, 1986

**Submitted to the Institute of Environmental
Sciences in partial fulfillment of the
requirements for the degree
of Master of Science**

Bogazici University Library



39001100131112

14

Boğaziçi University

1992

*To my family;
Katif,
Joseph, and
Anna Larissa.*

ACKNOWLEDGEMENTS

I would like to express my sincere gratitude to my thesis supervisor Doç.Dr.Miray Bekbölet for her helpful supervision and invaluable advise throughout the preparation of this work. Without her continual encouragement, this study could not have been completed. I wish to thank the members of my committee. Prof.Dr.Yüksel Inel for his valuable suggestions and for the permission to use his instruments during this work and Doç.Dr.Dilek Çalgan for their careful review of the final manuscript.

I would like to thank all my teachers and friends who helped me and especially Meltem Beyazıd and Fulya Bergin who tried to make everything easier for me in the experimental work.

I also would like to thank Alev Temel and Derya Gönenc for their help in using computer.

Thanks to the grants allocated by Boğaziçi University Research Fund (90 HY 0047) in support of this work.

Finally, I like to thank my family for their understanding and support in getting this thesis accomplished.

ABSTRACT

The semiconductor photocatalytic sterilization of *E.Coli* in drinking water was studied. The time course of viable *E.Coli* cells when cell suspensions of 10^3 cell/mL were subjected to irradiation of black light fluorescent lamps (3x8W Phillips TL and 1x125W Tungfram HgV) in the presence of TiO_2 was found to be approximately 60 min for sterilization. A decrease in viable cell numbers was not observed neither under light irradiation when semiconductor powders were absent nor under the dark conditions when semiconductor powders present. Various TiO_2 concentrations were applied and 1 mg/mL concentration for Experimental Set-up I with 3x8W Phillips TL, and 0.1-1.0 mg/mL concentration range for Experimental Set-up II with 1x125W Tungfram HgV was found to be optimum although initial viable cell count was reported as, another effective factor.

ÖZET

İçme sularındaki *E.Coli* mikroorganizmaların, yarı iletkenlerden yararlanılarak fotokimyasal sterilizasyonu üzerinde çalışılmıştır. 10^3 hücre/mL *E.Coli* ve yarı iletken TiO_2 (n-tipi) süspansiyonu, 3x8W Phillips TL 1x125W Tungfram HgV ile ışıklandırıldığında sterilizasyonun 60 dakikada yeterli olduğu gözlenmiştir. Aynı düzenekte TiO_2 bulunmadığında ve aynı düzenekte ışık kullanılmadığında canlı sayısında bir azalma görülmemiştir. Farklı TiO_2 konsantrasyonları uygulandığında 1mg/mL konsantrasyonu 3x8W Phillips TL düzeneği için 0.1-1.0 mg/mL konsantrasyonu 1x125W Tungfram HgV düzeneği için en uygun olduğu saptanmıştır. Ayrıca, başlangıçta bulunan *E.Coli* konsantrasyonunun sterilizasyon süresi üzerinde etkili olduğu anlaşılmıştır.

TABLE OF CONTENTS

	<u>Page</u>
ACKNOWLEDGEMENTS	iv
ABSTRACT	v
ÖZET	vi
TABLE OF CONTENTS	vii
LIST OF FIGURES	ix
LIST OF TABLES	xi
I. INTRODUCTION	1
II. THEORETICAL BACKGROUND	3
2.1. Bacteria	3
2.1.1. Cell structure of <i>E. Coli</i>	4
2.1.2. Growth of bacteria	7
2.1.3. Enumeration of bacteria	9
2.1.4. Significance in environmental science	10
2.2. Photoelectrochemical reactions	11
2.2.1. Photochemistry	11
2.2.2. Semiconductors	13
2.2.3. TiO_2 A photosensitive semiconductor	16
2.3. Disinfection	18
2.3.1. Chemical agents used for disinfection purpose	18
2.3.2. Mechanical means used for disinfection purpose	19
2.3.3. Radiation used for disinfection purpose	20
2.3.4. Physical agents used for disinfection purpose	20
2.3.5. Light source as a physical agent for disinfection	21
2.4. Photocatalytic sterilization of microbial cells	21
2.4.1. Photochemical reactions important in environmental sciences	21
2.4.2. Photochemical sterilization studies	22
2.4.3. Theoretical basis of photochemical sterilization.	24

	<u>Page</u>
III. EXPERIMENTAL	26
3.1. <i>E.Coli</i> cultivation and Enumeration Method	26
3.1.1. Materials	26
3.1.2. Growth of bacterial culture	27
3.1.3. Determination of the cell number	28
3.2. Photocatalytic reactions	29
3.2.1. Photocatalytic light source	29
3.3.2. Actinometric measurements	31
3.2.3. Experimental sets.	33
IV. RESULTS AND DISCUSSION	36
4.1. Results obtained from Experimental Set-up I.	36
4.2. Results obtained from Experimental Set-up II.	38
4.3. Results obtained from Experimental Set-up III.	40
4.4. Results obtained from the effect of different TiO ₂ concentrations in surviving ratio in Experimental Set-up I.	42
4.5. Results obtained the effect of different TiO ₂ concentrations in surviving ratio in Experimental Set-up II.	44
4.6. Effect of different TiO ₂ concentration on surviving ratio	46
4.6.1. Experimental Set-up I.	46
4.6.2. Experimental Set-up II.	48
4.7. Effect of initial E.Coli concentration on surviving ratio	49
4.8. Results for actinometric measurements	50
4.9. Effect of Temperature, pH and others	52
V. CONCLUSION AND RECOMMENDATIONS	53
VI. REFERENCES	60

LIST OF FIGURES

	<u>Page</u>
FIGURE 2.1. Classification of microorganisms belonging to the kingdom of protists	3
FIGURE 2.2. Representation of the cell wall of a gram-negative organism	5
FIGURE 2.3. Schematic diagram of <i>E.Coli</i>	6
FIGURE 2.4. Typical bacterial growth curve	8
FIGURE 2.5.a. Electronic orbitals and light absorption in an atom or molecule	12
FIGURE 2.5.b. Semiconductor bands and electron hole pair formation on light absorption.	12
FIGURE 2.6. Classification of semiconductors.	14
FIGURE 2.7. Anatase absorption	16
FIGURE 3.1. Experimental Set-up for the growth of bacteria	28
FIGURE 3.2. Emission spectrum of black light fluorescent lamps	30
FIGURE 3.3. Spectral intensity distribution of medium pressure mercury lamp	31
FIGURE 3.4. Experimental Set-up I	34
FIGURE 3.5. Experimental Set-up II	34
FIGURE 3.6. Experimental Set-up III	35
FIGURE 4.1. Time course of viable cell concentrations in Experimental Set-up I with 50 mg concentration, Without TiO ₂ and without illumination in 40 mL sterilized raw water.	36
FIGURE 4.2. Time course of viable cell concentration in Experimental Set-up II with concentration of 50 mg TiO ₂ /40 mL sterilized raw water.	39
FIGURE 4.3.a. Time course of viable cell concentrations in Experimental Set-up III with concentration of 50 mg TiO ₂ /40 mL sterilized raw water.	41

	<u>Page</u>
FIGURE 4.3.b. Time course of viable cell concentrations in Experimental Set-up III without the filter with concentration of 50 mg TiO ₂ /40 mL sterilized raw water.	42
FIGURE 4.4. Time course of surviving ratio in Experimental Set-up I with 10 mg, 50 mg 100 mg TiO ₂ concentration in 40 mL sterilized raw water.	43
FIGURE 4.5. Time course of surviving ratio in Experimental Set-up II with 10 mg, 50 mg 100 mg TiO ₂ concentration in 40 mL sterilized raw water.	45

LIST OF TABLES

	<u>Page</u>
TABLE 2.1. Composition of a rapidly growing <i>E.Coli</i> cell	7
TABLE 2.2. Comparison of the sensitivities of some methods of bacterial biomass estimation.	10
TABLE 2.3. Bandgap energy and λ_{bg} for semiconductors important to photoelectrochemistry	15
TABLE 2.4. Some properties of the different crystal structures	17
TABLE 4.1. Lethal effect of semiconductor powder (TiO_2) on <i>E.Coli</i> under various concentrations.	38
TABLE 4.2. Effect of different TiO_2 concentration on surviving ratio in Experimental Set-I (0-30 min)	47
TABLE 4.3. Effect of different TiO_2 concentration on surviving ratio in Experimental Set II (0-30 min)	48
TABLE 4.4. Effect of initial cell concentration on surviving ratio in time fix	49
TABLE 4.5. Actinometric results	51

I. INTRODUCTION

The interconversion of different forms of energy has been of central importance in science and technology. Just as the practical application of heat engine, electric generators, and storage batteries led to the development of the fields of thermodynamics and electrochemistry in the 19th and 20th centuries, so the problem of utilizing solar energy for the direct production of electricity and fuel has become a field of much current interest and has encouraged new fundamental investigations of interaction of light, electron flow, and chemical reaction with electrochemical cells.

Photochemical reactions could be employed to replace other energy consuming chemical process, for example, for pollution abatement or in chemical synthesis. One of the more promising approaches to the design of such systems involves the application of powder catalysts made of semiconductor materials.

n-Type semiconductor powders such as TiO_2 have been shown to be applicable to the photocatalytic oxidation of water; cyanide, and acetic acid. Light sensitived photochemical reactions involving TiO_2 on the surface have also been used for the degradation of contaminants in water. Recently the semiconductor powders were applied to the sterilization of microbial cells.

The sterilization of microbial cells is very important in the medical, bioindustrial and environmental field. Chemicals, antibiotics and bactericides have been used for this purpose. Microbial cells are also physically sterilized by heat-treatment and UV radiation. Water disinfection generally involves the use of chlorine. Besides disinfection, other benefits can result such as color removal, correction of tastes and odors and the suppression of unwanted biological growths. Chlorination process with many organic materials in water produce trihalomethanes and the implication of this problem has focused considerable attention on advantages and disadvantages of using chlorine and other processes mentioned above as a water disinfectant and has initiated an intense effort to evaluate other agents as water disinfectants.

To assess the sanitary quality of water, three major groups of microorganisms are used as indicator of bacterial pollution. These are coliforms, fecal coliforms and streptococci. For the assessment of potable water acceptability, coliform analysis is the mandatory procedure used by most countries in the world. Coliform organisms, while relatively harmless themselves, are generally present in water containing enteric pathogens. Because they are relatively easy to isolate and because they normally survive longer than the disease-producing organisms, coliforms are a useful indicator of the possible presence of enteric pathogenic bacteria and viruses. In most cases, water that is free of total coliforms is considered free of disease-producing bacteria.

The purpose of this study was to achieve a photochemical sterilization of drinking water using TiO_2 as a catalyst. The sterilization was carried out using various, black light fluorescent lamps with TiO_2 containing of drinking water slurries. Bactericidal effect was observed to take place within approximately 60 minutes in experimental set-up.

II. THEORETICAL BACKGROUND

2.1. Bacteria

Microorganisms are commonly grouped in three kingdom; protista, plants and animals. Protist kingdom is also divided into two groups procaryotes and eucaryotes. Bacteria is one form of procaryotes which does not contain nuclear membrane. The classification of microorganisms belonging to the kingdom of protists is shown in Figure 2.1.

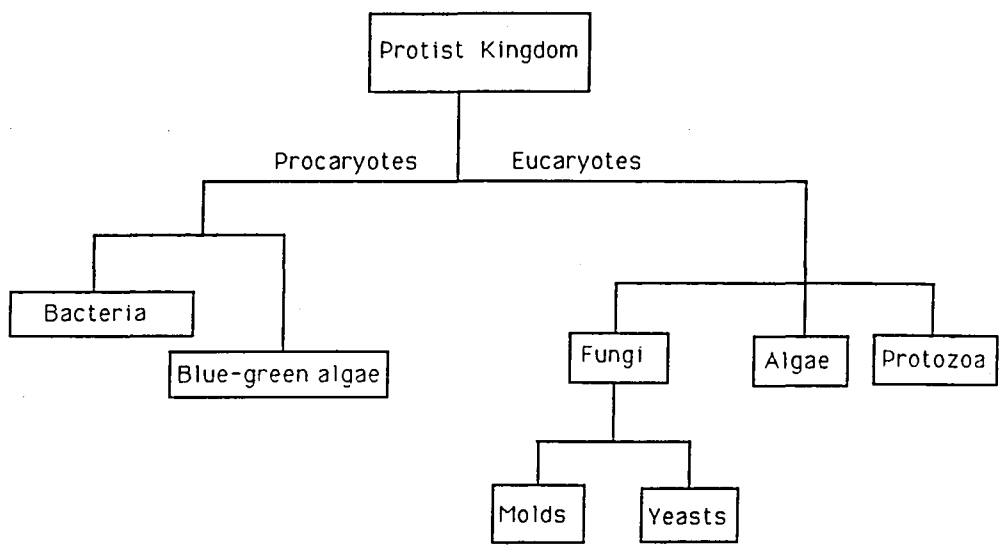

Figure 2.1. Classification of microorganisms belonging to the kingdom of protists.

Bacteria are relatively small organisms usually enclosed with rigid walls. They are typically unicellular, but they may exist in three basic morphological forms. Most cannot utilize light energy and they are mobile and reproduce by binary fission. There are many subdivisions of bacteria. Enteric or coliform bacteria is one of the subdivisions. *Escherichia Coli* is included in this group. The dominant morphological form consists of rods. *E. Coli* exists in the intestine of higher animals. The nutrition of coliform bacteria is simple organic compounds. *E. Coli* is not photosynthetic and doesn't form endospores. The gram reaction is negative [1].

2.1.1. Cell Structure of *E.Coli*

In general, most living cells are quite similar, having a cell wall, which may be either a rigid or flexible cell membrane. The interior of the cell contains a colloidal suspension of proteins, carbohydrates, and other complex organism compounds, called the cytoplasm.

Cell Wall: The rigid cell wall is the main structural component of most procaryotes. The functions of the cell wall are (i) to prevent rupture of bacteria due to osmotic pressure differences between intracellular and extracellular environments, (ii) to provide the characteristic shape of the bacteria. The thickness of the cell wall of Gram negative bacteria is about 10 nm and composed of a variety of aminoacids. Alanine, glycine, glutamic acid and lysine are some of common aminoacids (proteins). The cell walls of gram-negative bacteria are more complex than gram-positive bacteria and contain a wider range of aminoacids and significant amounts of lipid, polysaccharide and protein constituents. Figure2.2. shows the cell wall of a gram-negative organism [2].

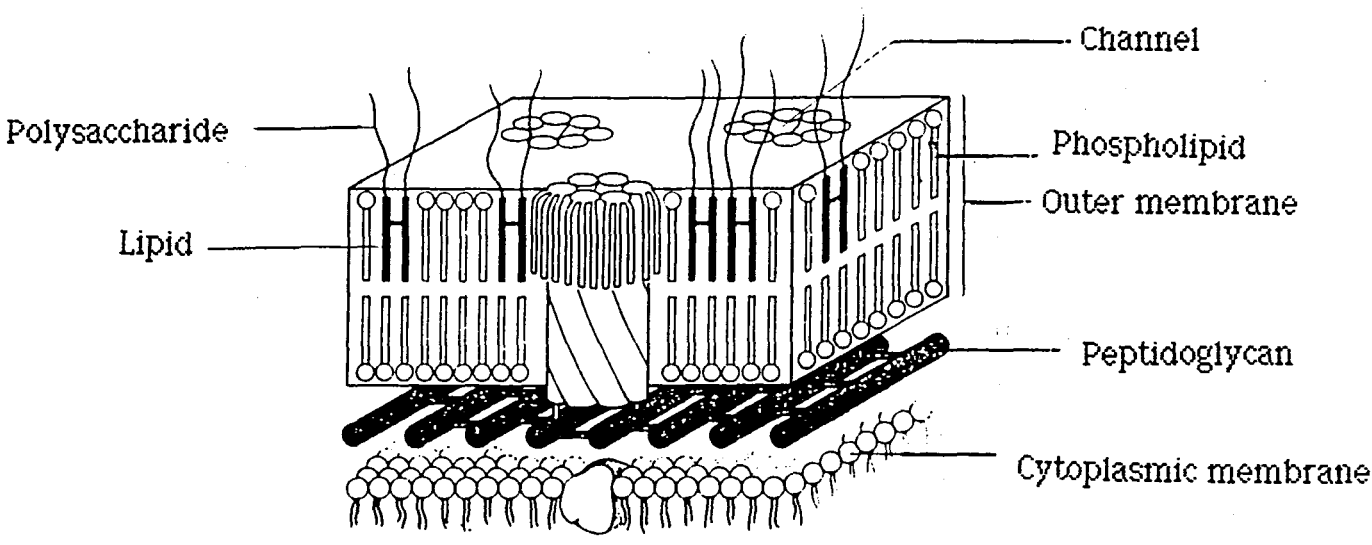

Figure 2.2 Representation of the cell wall of a gram-negative organism.

Cell Membrane: The cell membrane lies just beneath the bacterial cell wall. In addition to serving as an osmotic barrier to passive transport, the cell membrane participates in the active transport of various substances into the bacterial cell. The cytoplasmic membrane performs several functions vital to the life of the cell. A large number of enzymes concerned with the degradation of foodstuffs and the production of energy are associated with the membrane. Some enzymes located in the cytoplasm are attached to the cytoplasmic membrane (membrane-bound enzymes) most other enzymes (soluble enzymes) are located in the cytoplasm (Figure 2.3.).

Cytoplasm: The essential genetic information is contained within a single chromosome composed of a single DNA molecule. Ribozomes are free in bacterial cytoplasm. Bacterial ribozomes are important to the protein-synthesizing processes. Groups of ribozomes, held together by strands of messenger RNA, that is, polyribosomes or polysomes, are the sites for protein synthesis.

Other small molecules in the cytoplasm are amino-acids, nucleotides, simple sugars, glycerol, fatty acids, acetate, pyruvate, ketocacids etc.

Procaryotes lack the distinct nucleus of eucaryotes, and the associated structures and features such as mitotic apparatus, nuclear membrane and nucleus.

Figure 2.3. and Table 2.1. shows the schematic diagram of *E.Coli* and the composition of *E.Coli* cell respectively.

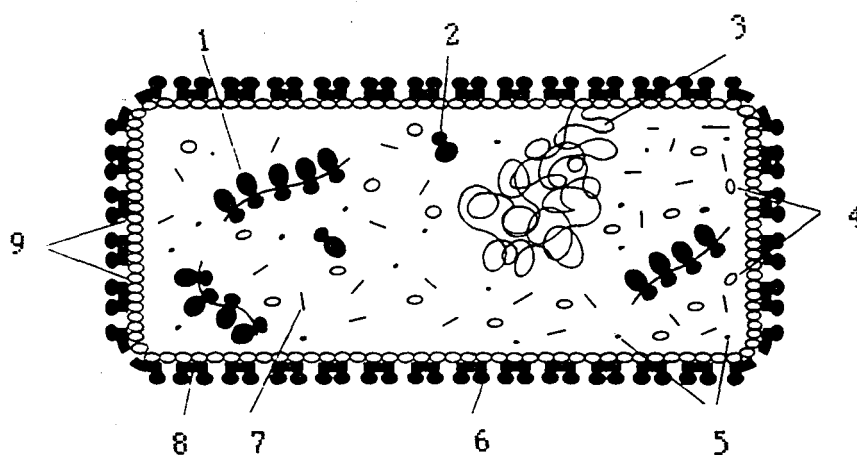

- | | |
|--|--|
| 1. Polyribosome | 6. Cell wall (polysaccharide and peptides) |
| 2. Free ribosome (protein and rRNAs) | 7. tRNA |
| 3. Chromosome (DNA) attached to cell membrane | 8. Cell membrane (lipid and protein) |
| 4. Free enzymes (protein) | 9. Enzymes attached to cell membrane. |
| 5. Small molecules (amino acids, nucleotides, simple sugars, glycerol, fatty acids, acetate, pyruvate, keto acids, etc.) | |

Figure 2.3. Schematic diagram of *E.Coli*

Table 2.1. Composition of a rapidly growing *E. coli* cell

Component	Percent of total cell weight	Average mol wt	Approximate no. per cell	No. of different kinds
H ₂ O	70	18	4x10 ¹⁰	1
Inorganic ions (Na ⁺ , K ⁺ , Mg ²⁺ , Ca ²⁺ , Fe ²⁺ , Cl ⁻ , PO ₄ ⁴⁻ , SO ₄ ²⁻ , etc.)	1	40	2.5x10 ⁸	20
Carbohydrates and precursors	3	150	2x10 ⁸	200
Amino acids and precursors	0.4	120	3x10 ⁷	100
Nucleotides and precursors	0.4	300	1.2x10 ⁷	200
Lipids and precursors	2	750	2.5x10 ⁷	50
Other small molecules	0.2	150	1.5x10 ⁷	200
Proteins	15	40,000	10 ⁶	2000-3000
Nucleic acids:				
DNA	1	2.5x10 ⁹	4	1
RNA	6			
16S rRNA	...	500,000	3x10 ⁴	1
23S rRNA	...	1,000,000	3x10 ⁴	1
tRNA	...	25,000	4x10 ⁵	40
mRNA	...	1,000,000	10 ³	1000

2.1.2. Growth of bacteria

When a small quantity of living cells is added to a liquid solution

of essential nutrients at a suitable temperature and pH, cells will grow. Associated with cell growth, are two other processes; uptake of some material from the cell's environment and release of metabolic end products into the surroundings, [1]. The rates of these processes vary widely as growth occurs.

The general growth pattern of bacteria in a batch culture is shown in Figure 2.4. Initially, a small number of organisms are inoculated into a fixed volume of culture medium, and the number of viable organisms is recorded as a function of time. The growth pattern based on the number of cells has four more or less distinct phases [3].

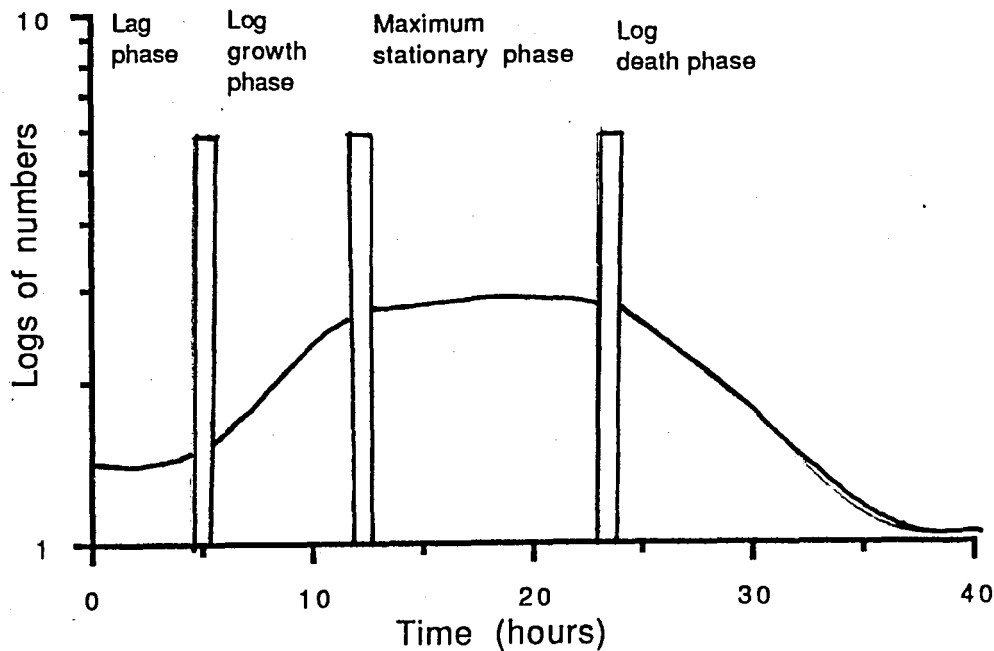

Figure 2.4. Typical bacterial growth curve

The lag phase: Represents the time required for the organisms to adapt to their new environment; the lag phase depends on the nutrient composition of the medium, on the size and age of the inoculum.

The log growth phase During this period the cells divide at a rate determined by their generation time and their ability to process food. As the amount of rate limiting substrate reaches to a minimum the cell mass approaches to a maximum level.

Stationary phase: At this phase the cell mass reaches its maximum concentration; some cells divide while others die. Usually dead cells break open, and internal components leak out. These components like carbohydrates, aminoacids etc. can be used as nutrients by living cells, thus maintaining the equilibrium between growth and death rates, the number of viable cells remains constant.

The death phase : During this phase the bacteria death rate exceeds the production of new cells. The death rate is usually a function of the viable population and environmental characteristics. In some cases, the log death phase is the inverse of the log-growth phase.

2.1.3. Enumeration of bacteria

The methods used to measure biomass are based on various types of measurements: mass, volume or linear extent, mass of a biomass component, mass of substrate consumed or product formed, metabolic rates, light scattering, cell and organelle counts (Appendix II), and finally staining methods.

The factors which influence the choice are: (i) the properties of the biomass, (ii) the properties of the culture medium, (iii) the accuracy required, (iv) the sensitivity required, (v) the required speed of measurement. The methods vary greatly in their sensitivity, speed and accuracy. A comparison of the sensitivities of the more commonly used methods for bacterial biomass measurement is given in Table 2.2. The least sensitive method is dry weight measurement and the most sensitive is the cell count [4].

Table 2.2. Comparison of the sensitivities of some methods of bacterial biomass estimation

Method	Minimum dry mass of bacteria required for an estimation with an error of < 2% (mg)
Dry weight	50
Biuret protein	1.0
DNA	1.0
Folin-Ciocalteu protein	10^{-1}
Opacity	10^{-1}
Cell count	10^{-5}

2.1.4. Significance in Environmental Science

To assess the sanitary quality of water, three major groups of microorganisms are used as indicator of bacterial pollution. These are coliforms, fecal coliforms and streptococci. For the assesment of potable water acceptability, coliform analysis is the mandatory procedure used by most countries in the world. Coliform organisms, while relatively harmless themselves, are generally present in water containing enteric pathogens. Because they are relatively easy to isolate and because they normally survive longer than the disease-producing organisms, coliforms are a useful indicator of the possible presence of enteric pathogenic bacteria and viruses. In most cases, water that is free of total coliforms is considered free of disease-producing bacteria.

Microbiologists generally agree that the presence of coliform bacteria in water strongly indicates that disinfection has not been

achieved. Likewise, they generally agree that the absence of coliforms suggests that disinfection is probably complete but is no guarantee that pathogens are not present in the water. It is generally recognized that coliforms can be inactivated more rapidly, and at much lower dosages of disinfectants (especially chlorine), than some enteric viruses and protozoan cysts. The coliform tests has served the water industry well for many years. Development of procedures using other indicator organisms should be pursued vigorously in order to develop a technique for monitoring water that are difficult or for use in those instances when grossly polluted waters must be used as a water source [5].

2.2. Photoelectrochemical reactions

2.2.1. Photochemistry

Photochemistry is the chemical change that may be brought about by the absorption of light. The possible behavior of a photochemically excited molecule are as follows: [6]

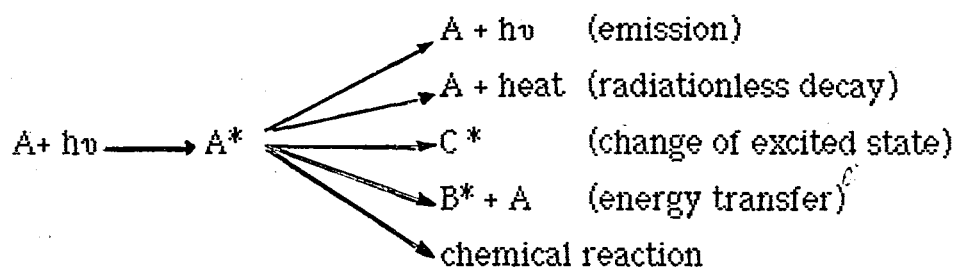

The long wavelength limit is approximately in the near infrared (~2000 nm) and the region of interest extends into the vacuum ultraviolet and is limited normally at the wavelength where radiation becomes appreciably "penetrating x-rays" [7].

The conversion of light to electrical or chemical energy results from light in the visible region acting as an electron pump. The

absorption of a photon by an atom or molecule brings, an electron from a lower orbital to a higher one (Figure 2.5A).

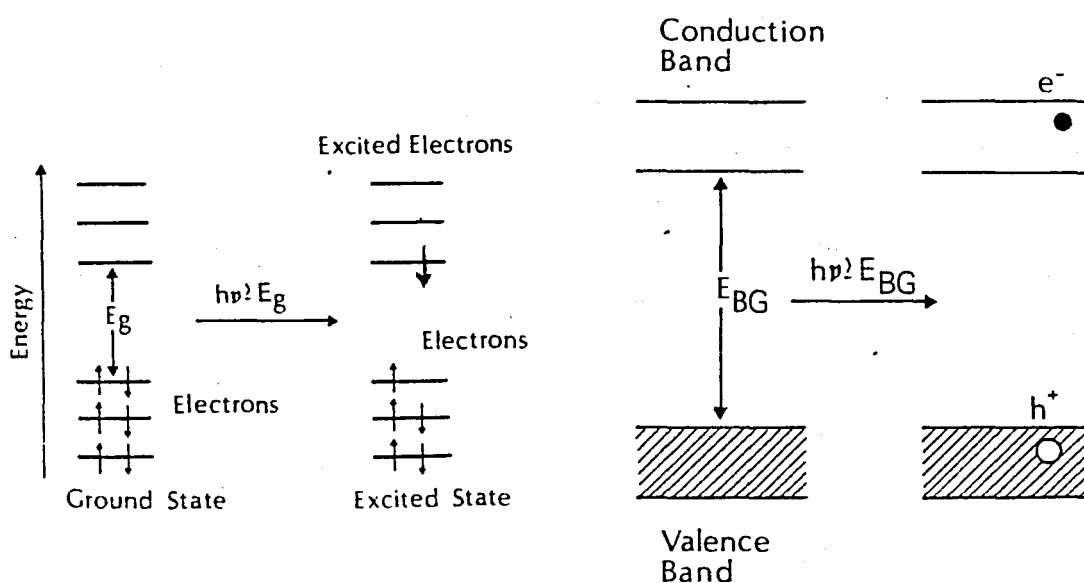

Figure 2.5.A

Figure 2.5.B

Figure 2.5.A. Electronic orbitals and light absorption in an atom or molecule

Figure 2.5.B. Semiconductor bands and electron hole pair formation on light absorption.

The wavelength of light that causes such a transition is that with an energy equal to or greater than the difference in energies of the two orbitals, E_g . On the other hand in a semiconductor the result of photon absorption is an electron-hole pair (e^-h^+) formed by this intramolecular pumping in species, S. This produces an excited state, denoted S^* . If the e^-h^+ pair can be separated so that the e^- flows to a suitable acceptor species, A, or an electron from suitable donor, D, fills h^+ .



The light energy has been stored, in this way, as a redox chemical energy. However excited states are very short lived and the e^-h^+ pairs frequently

recombine very quickly with the captured light energy degraded to heat or, sometimes with the emission of a photon, as in phosphorescence. To utilize the light in a form other than heat, one must achieve separation of the e^-h^+ pair before recombination [8].

Light absorption occurs in a similar way in a semiconductor (Figure 2.5.B). In semiconductors the orbitals are merged into a nearly filled valence band and a nearly vacant conduction band separated by the energy gap, E_G . When a semiconductor is immersed in a solution, charge transfer occurs at the interface because of the difference in the tendency of the two phases to gain or lose electrons. The net result is the formation of an electrical field at the surface of the semiconductor to a depth of 5 to 200 nanometers. The direction of this electric field depends on the relative electron affinities of the semiconductor and solution.

2.2.2. Semiconductors:

A semiconductor is a material having an electrical conductivity intermediate between that of metals and insulators. Some of the electrons in electrical conductors such as metals are relatively mobile, whereas in nonmetals or insulators the electrons are much less mobile, and larger amounts of energy must be expended in order to induce these electrons to move to another location in the substance.

The electrons in the outer principal energy level of a solid material can be considered to be located in the valence band or valence energy level. When the electrons gain sufficient energy to become mobile enough to move to another location and retain that mobility, then these electrons can be considered to be in the conduction band or conduction energy level. The energy difference between the valence band and the conduction band is known as band gap (Figure 2.5.B). In the conductor-type materials, there is a relatively small gap, therefore electrons gain small amounts of energy necessary to move into the conduction band and

thereby to become mobile. In nonconductors, which can be forced to conduct electric currents at relatively higher voltages, this energy difference between the valence and conduction bands is much greater. A group of substances, known as semiconductors; have band gaps that are intermediate between those of conductors and those of nonconductors [9]. Table 2.3. list the values of E_{bg} and λ_{bg} for several semiconductors in photoelectrochemistry.

Semiconductors are classified as extrinsic and intrinsic (Figure 2.6.)

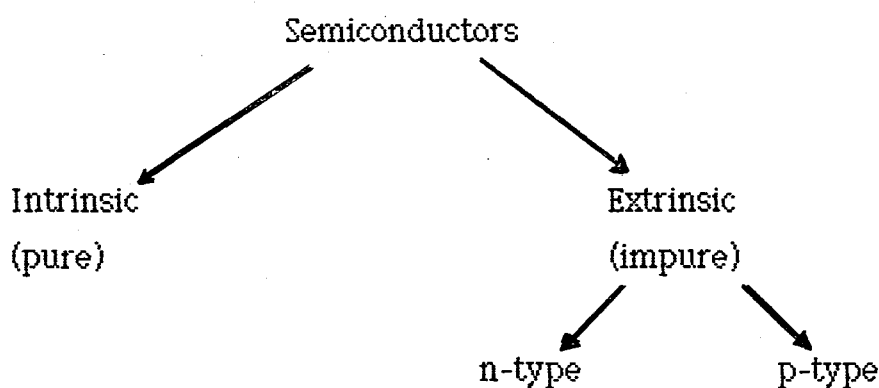

Figure 2.6. Classification of semiconductors

The intrinsic semiconductor has a complete octet of electrons around the central atom. The p-type impurity provides a vacancy or positive hole, where an electron could fit to form a neutral volume. An n-type impurity has an extra, more mobile electron, used for the bonding of the central atom in the crystal lattice.

For an n-type semiconductor when light is absorbed at the interface, the electron moves toward the bulk of the semiconductor and the hole moves toward the surface. If the solution contains an electron donor species, which has an energy level above that of photogenerated

hole at the surface the electron transfer reaction occur. Thus photogenerated holes produced at the n-type semiconductor may cause oxidation of the semiconductor surface [8].

TiO₂ is an n-type semiconductor, and it is the presence of the physical defects that causes semiconductivity of the oxide to appear. These imperfections introduce quantum levels in the energy gap between the valence and conduction band edges [10].

Table 2.3. Bandgap Energy and λ_{bg} for semiconductors important to photoelectrochemistry

Semiconductor	Bandgap Energy (eV)	λ_{bg} (nm)
SnO ₂	3.5	350
TiO ₂ (anatase)	3.2	390
TiO ₂ (rutile)	3.0	410
CdS	2.4	520
Gap	2.3	540
Gas	1.4	890
Inp	1.3	950
Si	1.1	1130

The anatase type of TiO₂ has a band gap energy of 3.2eV which corresponds to a wavelength of 390 nm Anatase absorption is given in Figure 2.7.

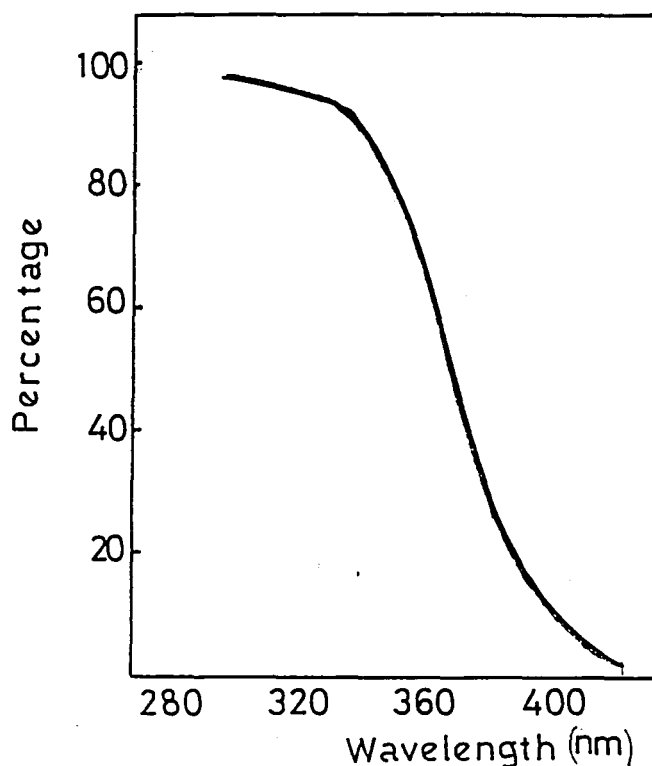

Figure 2.7. Anatase absorption

Wavelength <400 nm is necessary to produce the reactions considered.

2.2.3. Titanium Dioxide (TiO_2): A photosensitive Semiconductor

Titanium dioxide has three different crystal structures: rutile, anatase, and brookite. Rutile crystals are tetragonal, anatase crystals are slender tetragonal prisms and brookite crystals are fat orthorhombic plates. Pure titanium dioxide is white or colorless; impurities (iron, niobium, chromium, tantalum and vanadium) sometimes cause it to be yellow, red, brown, or black. The anatase and brookite forms change to the rutile form when they are heated to approximately 800°C . The rutile form melts between 1830°C and 1850°C . It is difficult to get titanium dioxide to dissolve or react. In the few situations where titanium dioxide does react, the product is usually a complex oxide. Titanium dioxide is not only relatively inert chemically, but also it is relatively inert physiologically. All three forms of titanium dioxide have very high refractive indices and are moderately hard and dense. Because its

refractive index is so much higher than that of other materials, mixtures which contain small titanium dioxide particles reflect almost all light and are opaque [11]. Table 2.4. shows some properties of the three crystal structures.

Table 2.4. Some properties of the different crystal structures

Crystal structure	Refractive index	Density g/cm³	Hardness Moh's scale
Rutile	2.7	4.26	5.5 - 6.0
Anatase	2.5	3.84	5.5 - 6.0
Brookite	2.6	4.17	6.0 - 6.5

Titanium dioxide, a pure white compound having high reflectivity is ideal for use in white paints, enamels and lacquers, and can be used in conjunction with other pigment compounds in colored paints. It is also used in pigments for rubber, paper, oilcloth, leather, textiles, inks, ceramics and floor coverings [12]. Another property of TiO_2 arouse interest when in the 1950's Renz showed that TiO_2 becomes markedly photosensitive in the presence of certain organic liquids and reducing solutions, particularly glycerol [13]. Since then, the ability of TiO_2 to mediate photoelectrochemical reactions in solution has been explored. Many aspects of the photoelectrochemistry of the oxide have been investigated with the main interest focused on the establishment of charge transfer mechanisms, the development of radiant energy converters to the electrical and/or chemical energy, and the development of functional devices.

2.3. Disinfection

Disinfection refers to the selective destruction of disease-causing organism. All the organisms are not destroyed during the processes. This differentiates disinfection from sterilization, which is the destruction of all organisms [3]. Disinfection is commonly accomplished by the use of chemical agents, physical agents mechanical means and radiation.

2.3.1. Chemical agents used for disinfection purpose

Chemical agents include chlorine and its compounds, bromine, iodine, ozone, phenol and phenolic compounds, alcohols, heavy metals, quaternary ammonium compounds, hydrogen peroxide, various alkalis and acids.

Water disinfection generally involves the use of chlorine. Besides disinfection, other benefits can result such as color removal, correction of tastes and odors, and the suppression of unwanted biological growths [14].

Chlorine is usually added to water as an aqueous chlorine solution by using chlorine gas that hydrolyzes in ammonia-free water to form hypochlorous acid and the hypochlorite ion. The hypochlorite and hypochlorous ion concentrations in water are reported collectively as the free chlorine residual. Chloramines are those chlorine species formed by the reaction of hypochlorous acid and ammonia in water, and they are not as effective relative to the free chlorine as a biocide for the microorganisms normally found in water. The reaction of free chlorine with many organics produces THMs, and the implication of this problem has focused considerable attention on advantages and disadvantages of using free chlorine as a water disinfectant and has initiated an intense effort to evaluate other agents as water disinfectants [5].

Chlorine will continue to be the primary water disinfectant for at least the next decade, but chlorination is a continuously improving technology and is being practiced more widely to provide an even more reliable and effective disinfection process.

Bromine and iodine are used for swimming pool water but have not been used for treated wastewater [3].

Ozone, a strong oxidizing agent that has similar bactericidal properties to chlorine has been found to be equal or superior to chlorine in its viricidal effects [5]. Ozone forms no known-by products that may be of significance to human health when used as a primary disinfectant and may result in the use of less residual disinfectant when a second disinfectant is employed. For many treatment plants, ozonation is used in conjunction with the pure-oxygen activated-sludge process which appears to be the most economical alternative for disinfection or in combination with a catalyst such as ultraviolet light.

Wolfe et al [15] reported on the relative efficiency of a variety of disinfectants. For common indicator organisms, they found chlorine to be most effective followed by ozone, peroxone, and chloramines. This in contrast with many studies that have found ozone to be more effective than chlorine [16].

2.3.2. Mechanical means used for disinfection purpose

Bacteria and other organisms are also removed by mechanical means during water treatment. The removals are a by product of the primary function of the processes. Coarse screen, fine screen, grit chambers are some mechanical treatment processes [3].

2.3.3. Radiation used for disinfection purpose

Ultraviolet radiation has been applied with some success to air and water sterilization. However, the poor penetration of the rays is a limiting factor [17]. Material to be sterilized must be passed over a surface of a suitable lamp in thin layers if the treatment is to be effective. UV units are recommended when chlorination is to be avoided. Water UV systems have been shown to kill coliforms, three types of polio viruses, several types of ECHO virus, coxsackie viruses and some reoviruses.

The inactivation of bacteria by UV radiation results primarily from the absorption of the radiation by the DNA of microorganisms [18]. The germicidal effect of UV radiation is greatest in the far ultraviolet (190-300nm) wavelength range [19]. In experiments on ultraviolet killing of *E.Coli*, certain suspensions, although treated in the same manner as others, were observed to exhibit a lower incidence of mutation or death. Further investigations showed that the length of exposure to visible light to which the suspensions were subjected after UV exposure but prior to their placement in the dark incubators correlated well with the decrease in mutation or kill efficiency. This *photoreactivation* was found to be caused by an enzyme active in the presence of visible light (540-420nm) but not in a dark environment. *Dark reactivation* may also occur by a mechanism that appears to be quite different from photoreactivation. To avoid *dark reactivation*, the irradiated suspension must be stored cold or in an inadequate growth medium prior to the completion of the experiment [17].

2.3.4. Physical agents used for disinfection purpose

Physical disinfectants that can be used are heat and light. Heating water to the boiling point, will destroy the major disease-producing non-spore forming bacteria. Heat is commonly used in the beverage and dairy

industry, but it is not a feasible means of disinfecting large quantities of waste water because of the high cost. However, pasteurization of sludge is used extensively in Europe [3].

2.3.5. Light Source as a Physical Agent for Disinfection

Ionizing electromagnetic radiation include alpha, beta, gamma, and x-rays, cathode rays and high-energy protons and neutrons. On absorbing such radiation, an atom emits high-energy electrons, thus ionizing its molecule. The ejected electron is absorbed by another atom, creating a chain of ionizations, or an ionization path, in the irradiated substance. This activity excites chemical groups in the microbial cell, causing the production of highly reactive, short-lived chemical radicals. Such radicals may alter chemical groups in DNA or actually break DNA strands causing the death of the cell [17].

2.4. Photocatalytic sterilization of microbial cells

2.4.1. Photochemical reactions important in environmental sciences

Metal semiconductor (TiO_2 , ZnO , CdS , WO_3 and SnO_2) have been utilized widely in photocatalytic processes for the degradation of environmental contaminants via light-induced redox-reactions at the semiconductor/solution interface. The oxidation of carbon monoxide (CO to carbon dioxide (CO_2)) the oxidation of cyanide (CN^-); the oxidation of sulfide (SO_3^{2-}); and the decarboxylation of acetic, propionic, and butyric acids have been investigated before 1980 (20,21,22,23,24,25). Other processes mentioned include chloride transfer to ethane from carbon tetrachloride (CCl_4), fluorotrichloromethane (CFCl_3), and difluorodichloromethane (CF_2Cl_2) and dechlorination of CF_2Cl_2 and CFCl_3 on illumination zinc oxide (26,27). A report in 1976 noted the release of

chloride ion upon illumination of TiO_2 , in the presence of chlorinated biphenyls [28]. Ollis (1985) investigated the degradation of chloromethanes and bromomethanes, chloroethanes, chloroethylenes and bromoethylenes, chlorobenzene, and chloroacetic acid in dilute aqueous solutions [29]. Matthews (1986) investigated the decomposition of chlorobenzene, benzoic acid and 4-chlorophenol [30].

2.4.2. Photochemical sterilization studies

Onoda et al. (1988) investigated the photocatalytic bactericidal effect of powdered TiO_2 on *streptococcus mutans* by which dental caries seems to be caused. A definite amount of culture was diluted with the physiological salt solution and directed to the photocatalytic experiment. Two types of fluorescent lamps (FL 20S. BL and FL20SS. W-F/18, Toshiba Corporation) were used and the solution was set 5 cm apart from the light source. It was emphasized in these results that the irradiated TiO_2 powder had the bactericidal effect on *S. mutans* and also this effect was more prominent in near ultraviolet radiation than in visible radiation. The time required for bactericidal effect was dependent on the kind of TiO_2 . There was no bactericidal effect of TiO_2 in the dark. The superiority of anatase TiO_2 in a photo-catalytic bactericidal effect can be attributed to their different band gap energy; 3.2 eV and 3.0 eV for anatase and rutile respectively. The optimum concentration range of TiO_2 compared with rutile TiO_2 powders for the bactericidal effect were between 0.01 and 0.1wt % [31].

Matsunaga et al. (1988) investigated the photochemical sterilization system in which *Escherichia Coli* were sterilized with photoconductor powders (TiO_2). Microbial cells were killed photoelectrochemically with TiO_2 powders. CoA in the whole cells was photoelectrochemically oxidized and, as a result, the respiration of cells was inhibited [32].

Previously it has been reported by the present author's group that microbial cells are electrochemically oxidized on a graphite electrode and that the electron transfer between microbial cells and the electrode is mediated by intracellular CoA [33, 34]. Electrochemical oxidation of microbial cells resulted in a decrease of respiratory activity and in cell death when a constant potential was applied to cells of *S.cerevisae* attached to the electrode surface [35]. Therefore the electrode system was applicable to sterilization of microbial cells in suspension.

Matsunaga et al.[36] were also reported that differences in the peak potentials may be used to classify some microbial cells. When the potential of the graphite electrode was run in the range of 0 to 1.0 versus saturated calomel electrode (SCE), gram positive bacteria gave peak currents at 0.65 to 0.69 V versus the S.C.E. The peak potentials of gram-negative bacteria were 0.70-0.74 versus the S.C.E. It was found that the peak currents result from the electrochemical oxidation of coenzyme A in the cell of *Escherichia Coli* and *Lactobacillus acidophilus*.

Matsunaga et al. (1988) constructed a continuous-sterilization system consisting of a TiO_2 immobilized acetylcellulose membrane reactor, a mercury lamp, and a masterflex lamp. As a result under various sterilization conditions examined, *E.Coli* (10^2 cells/mL) was sterilized to <1% survival when the cell suspension flowed in this system at a mean residence time of 16.0 minutes under irradiation (1.0×10^{21} quanta/ m^2 .sec.). They have found that the system was reusable [37].

In the case of sterilization by TiO_2 powders the materials used were: Titanium dioxide (Aerosil P.25 anatase type); nutrient broth containing 1 g. of beef extract, 1 g. of peptone, 0.5 g. of sodium chloride in 100 mL of deionized water.

Cells of *Escherichia Coli* were grown under aerobic conditions at 37°C for 12 hrs. in 100 mL of nutrient broth (pH 7.2). The cell concentrations were determined with a hemacytometer. The 10 mg of TiO₂ were suspended in sterilized water. The suspended cells were added to the solution containing TiO₂ powders. The reaction vessel was illuminated with a mercury lamp (HF 100x) at a light intensity of 6.6×10^{20} quanta/m².sec. The light intensity was measured in the center of the vessel surface with a radiometer and corrected for the adsorption of UV radiation by the glass.

The number of viable cells in the solution was determined by plating suitably diluted samples and then counting the colonies which appeared on the nutrient broth agar plate after 24 h of incubation at 37°C.

Under illumination, the number of viable cells decreased gradually, and sterilization was complete after 60 min. On the other hand a decrease in viable cell numbers was not observed under light irradiation when semiconductor powders were absent. Sterilization of *E.Coli* was carried out at various concentrations (10^2 , 10^3 , 10^4 and 10^5 cells per mL). With a mercury lamp at a light intensity of 6.6×10^{20} quanta/m².s 10^2 cells/ml and 10^3 cells/ml were completely sterilized in 30 minutes whereas cells of concentration of 10^4 and 10^5 (cells/mL) the surviving ratio increased with an increase in the initial cell concentration.

2.4.3. Theoretical basis of photochemical sterilization

The mechanism of sterilization by TiO₂ powders was explained by Matsunaga and coworkers [32, 33, 37] A brief outline of their findings will be presented here.

It has been shown in the recent years by the present authors that

CoA mediates an electron transfer between cells and an electrode. When whole cells of *S.cerevisiae* were electrochemically sterilized with graphite electrode the CoA content decreased in the cell. The CoA content of the cell was measured enzymically by phosphotransacetylase after the cells were sonicated. The CoA content of *S.cerevisiae* decreased from 36 nmol/10⁸ cells to 1 nmol/10⁸ cells where as 21 nmol/10⁸ cells of CoA were retained when cells were incubated without semiconductor powders under light irradiation. The respiratory activity of the cell was also measured by an oxygen electrode. When cells were incubated with TiO₂/Pt particles under the some conditions, the respiratory activity decreased to 42% of the initial respiration rate. These facts suggest that oxidation of CoA in the whole cells resulted in both inhibition of respiration and death of cells. However, destruction of cell wall by photoconductor particles has not been observed by either light or electron microscopy. When the TiO₂/Pt particles were separated from whole cell suspensions of *S.cerevisiae* by a dialysis membrane to prevent direct contact between cells and electrode, both the respiratory activity and viability of cells did not decrease.

Therefore, the loss of respiratory activity and viability seems to be due to a direct oxidation of the microbial cell.

Yeast, Gram-positive bacteria, Gram-negative bacteria, green algae are also oxidized with the same manner, having different cell wall composition. As a result various microorganisms can be killed with semiconductor powders.

III. EXPERIMENTAL

3.1. *E.Coli* Cultivation and Enumeration Methods

3.1.1. Materials

Microorganisms: *Escherichia Coli* strain HB 101 was provided from Biology Department, Boğaziçi University.

Semiconductor Powder: TiO_2 powders (anatase type) which has a BET surface area of $50\text{m}^2\text{g}^{-1}$ and an average particle size of 30 nm was provided from Degussa (P25 grade)

Medium : *Luria Bertani* LB medium;

Tryptone (Difco) 10 g.

Yeast extract (Difco) 5 g.

NaCl (Merck) 10 g.

were added to one liter of deionized and distilled water

Sterile saline solution: 0.85% NaCl in distilled water

Phosphate buffer solution: 0.1M. KH_2PO_4 and 0.1M. K_2HPO_4 solutions were mixed to reach a final pH of 7.0.

Sterilized water Unchlorinated raw water was provided from ISKI, Büyükçekmece Water Treatment Plant and sterilized at the autoclave for 15 minutes at 121°C .

All glassware were cleaned thoroughly with a detergent and rinsed with hot water to remove all traces of residual washing compound. They were sterilized at 170°C for two hours. Pipetman tips were washed then sterilized at the autoclave at 121°C for 15 minutes. Salinated water,

LB medium, phosphate buffer are autoclaved at 121°C for 15 minutes [39].

LB medium supplemented with 15-20 g./L of Agar (Difco) was used to prepare petri dishes containing solid medium which were used for colony counting to determine viable cell number. Sterilized LB agar were poured into petridishes (~ 35 mL) then they were incubated at 37°C for one day in order to evaporate the water on the surface of the solid agar and to eliminate those contaminated.

The strains of *E.Coli* were kept in glycerol solution at -70°C. To prepare master plate, frozen glycerol cultures were cloned twice by streaking on LB agar plates then incubated at 37°C for overnight. One isolated colony was removed from the master plate to prepare sub-plate over which many well isolated colonies were obtained to use in experiment. Streaking technique is given in Appendix I [39].

3.1.2. Growth of the bacterial culture

For the inoculation, one isolated colony was removed by the loop from the masterplate and transferred in 25 mL of sterilized LB medium.

Experiments were done in 100 mL erlenmeyer flasks with 25 mL of culture medium. The flask were prepared and incubated overnight in shaking-water bath (NUVE BM 101) thermostated at 37°C. Shaking provided the necessary oxygen transfer into the medium. All the materials were sterilized before. The flasks were made of glass resistant to sterilization heat. Cotton plugs were placed on top of the erlenmeyer flasks to prevent contamination and to filter the air entering the flask.

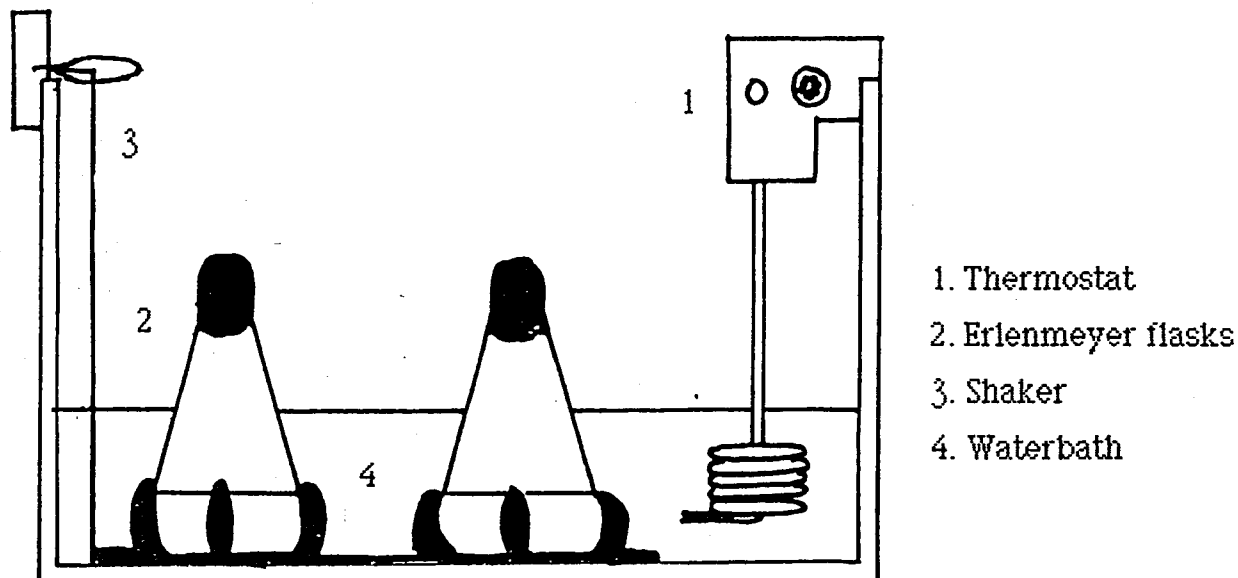

Figure 3.1. Experimental set-up for the growth of bacteria

After the incubation each flask contained approximately 1×10^{10} cells/mL. The appropriate dilutions are shown below.

3.1.3. Determination of the cell number

For the determination of the cell concentrations, appropriate (serial) dilutions were made according to the following procedure.

	dilution factor	approximate concentration
$10 \mu\text{L A} + 990 \mu\text{L SW} = 1000 \mu\text{L Epp1}$	10^{-2}	10^8 cells/mL
$10 \mu\text{L Epp1} + 990 \mu\text{L SW} = 1000 \mu\text{L Epp2}$	10^{-4}	10^6 cells/mL
$10 \mu\text{L Epp2} + 990 \mu\text{L SW} = 1000 \mu\text{L Epp3}$	10^{-6}	10^4 cells/mL
$100 \mu\text{L Epp3} + 990 \mu\text{L SW} = 1000 \mu\text{L Epp4}$	10^{-7}	10^3 cells/mL
$100 \mu\text{L Epp4} + 990 \mu\text{L SW} = 1000 \mu\text{L Epp5}$	10^{-8}	10^2 cells/mL

Free Cell culture = A

Eppendorf tubes = Epp

Salinated water = SW

For determination of viable cell number, the culture aliquots were serially diluted by the ratio 1:100 and then 1:10 in sterile saline (0.85%); 50 μ L of appropriate dilutions were spread on duplicate LB agar plates, and incubated overnight at 37°C. Colonies were counted by using Quebec colony counter. The number of viable cells per mL was then calculated from the average number of colonies counted on duplicate plates, after correction by the dilution factor. More details about spreading technique are given in Appendix I.

The counts were conformed to a Poisson distribution [4]. If n is the number of organisms counted, the standard deviation is given by $\sigma=n^{1/2}$ and the 95 % confidence limits are taken to be $n\pm 2\sigma$,

3.2. Photocatalytic reactions

3.2.1. Photocatalytic light sources

Many types of light sources are available for the initiation of photochemical reactions. The most important parameters for the selection of a particular light are:

1. The wavelength of the light and the intensity should be sufficient to induce a reaction in a reasonable time (15min-10hr). The intensity should be, around 10^{18} quanta/sec.cm².
2. The light intensity should be stable during the photolysis [41].

Black light fluorescent lamps and medium pressure mercury lamp were used for the experimental set-ups.

Light source used in Experimental set up I: Three 8 watts commercial black light tubular fluorescent lamps (3x8W Phillips TL) were used and the system was irradiated from the bottom.

Light source used in Experimental set up II: 1x125 Tungfram HgV black light source lamp was used and the system was irradiated from one side.

The emission spectrum of a typical black light fluorescent lamp is given in (Figure 3.2.) [40]. Black light lamps emit predominantly 320-440 nm light, with virtually no emission below 300 or above 500 nm. The inside wall of the lamp is coated with a fluorescent substance which emits in a broad band around 365 nm, and does not allow the short UV to pass through. They have continuous spectra and known as low-pressure mercury arc.

By comparing figures 2.7 and 3.2 it can be seen that the lamp emits in the region of maximum absorption of the catalyst. Actinometric measurement of light intensity is given in later section.

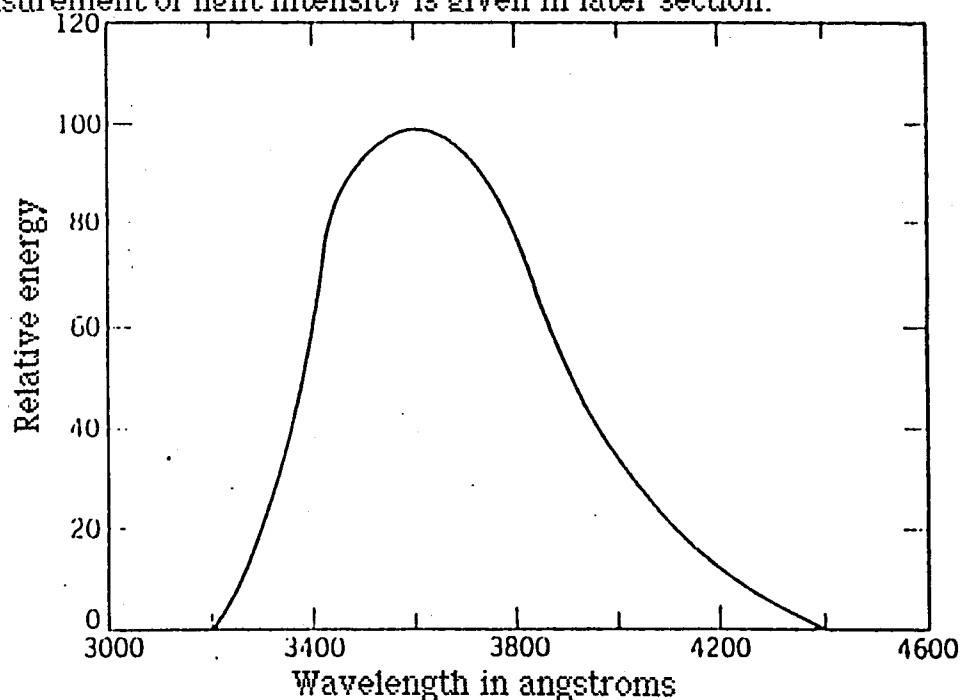

Figure 3.2. Emission spectrum of black light fluorescent lamps.

Light source used in Experimental Set-up III: An optical bench containing the light source, the lens and a filter (U2G) was used. The light is absorbed from the top with a mirror interposed at 45° . The excitation source is 250 W medium pressure mercury lamp. The relative energy distribution of a medium pressure lamp is given in Figure 3.3. As can be seen from the figure the light source is a line spectra, consists of high energy at definite wavelength separated by intervals in which no energy appears [41].

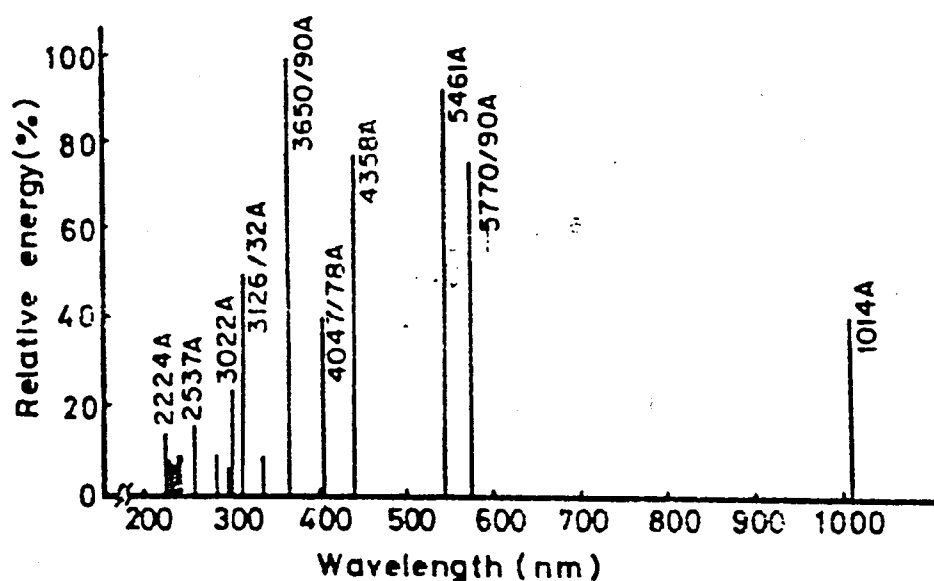

Figure 3.3. Spectral intensity distribution of medium pressure mercury lamp

3.2.2. Actinometric measurements

Light-source intensity is measured by chemical actinometer. Chemical actinometers are photochemical reactions that have been calibrated directly or indirectly by relation to a known heat flux [41]. Many chemical actinometers are known in the liquid phase. The most important parameters that must be fulfilled are: stability, concentration

temperature independancy and quantum efficiency. Potassium ferrioxalate actinometer having wavelength range of 250-570nm is accepted as the most suitable liquid phase chemical actinometer developed by Parker and Hatchard.

The mechanism of the potassium ferrioxalate actinometer is the reduction of ferric ions to the ferrous state. The potassium ferrioxalate solution with sulphuric acid is irradiated within the above wavelength range, the Fe^{+3} ions are reduced to Fe^{+2} ions, and the formed Fe^{+2} ions form a red colored complex when reacted with phenanthroline reagent. This red colored has an absorption maximum at 510 nm. The reaction can be expressed as follows:



The quantum yield that is determined according to the above reaction has small dependence on reactant and product concentrations, intensity of the incident light and temperature.

Preparation of the actinometer solution [42]

Potassium Ferrioxalate solution: Pure $\text{K}_3\text{Fe}(\text{C}_2\text{O}_4)_3 \cdot 3\text{H}_2\text{O}$ was prepared by mixing 1 volume of 1.5 M ferric chloride with 3 volumes of 1.5M potassium oxalate solution. Potassium ferrioxalate precipitated and the precipitated had to be crystallized and dried in a current of warm air at 45°C. The pure green crystals of potassium ferrioxalate could be stored in the dark for a long time. 0.006M solution was prepared by dissolving 2.947 g of solid in 800 mL of H_2O and 100 mL 1.0 M H_2SO_4 were added and the solution was diluted to 1 L with H_2O and mixed. The preparation of potassium ferrioxalate solution must be carried out in the absence of actinometrically active light.

1.10 Phenanthroline monohydrate solution:

0.1 % by weight 1.10 phenanthroline monohydrate solution was prepared by dissolving 0.1 g. solid in water.

Buffer solution

Buffer solution was prepared by mixing 600 mL of 1 N sodium acetate with 360 mL of 1 N H_2SO_4 and diluted to 1L with distilled water.

Procedure for actinometry [42]

Identical conditions were set up for the actinometric measurements. 40 mL of ferrioxalate solution were irradiated for each light source for 30 minutes. After irradiation and mixing well, an aliquot volume of 2 mL (V_1) was taken into 50 mL (V_3) volumetric flask and 1 mL 1.10 phenanthroline solution and 1 mL of buffer solution were added. The final volume was adjusted with distilled water. A blank solution was prepared in the same way except that it was not irradiated. Both solutions were kept in the dark (about 30 minutes) until full color development was achieved.

The absorbance of the samples was measured at 510 nm with the spectrophotometer (varian supercan 3). The absorbance of this solution is a measure of the quantity of light absorbed by the actinometer.

3.2.3. Experimental sets

Experimental Set-up 1.: Experimental setup 1 was consisted of 3x8W black light fluorescent lamps placed horizontally and parallel to each other (Figure 3.4) TiO_2 suspensions was prepared by sonicating 5 minutes before *E.Coli* addition. 100 ml Erlenmeyer flasks were used as a reaction vessel. Reaction vessel containing certain amount of TiO_2 in *E.Coli* suspension was placed on top of the lamps providing illumination from

Extreme care was paid to exclude any actinometrically active light during experiments. Mixing was provided by shaking before sampling (every 10 minutes) in order to prevent the TiO_2 powders to settle down. Standard plate count were done for the sampling.

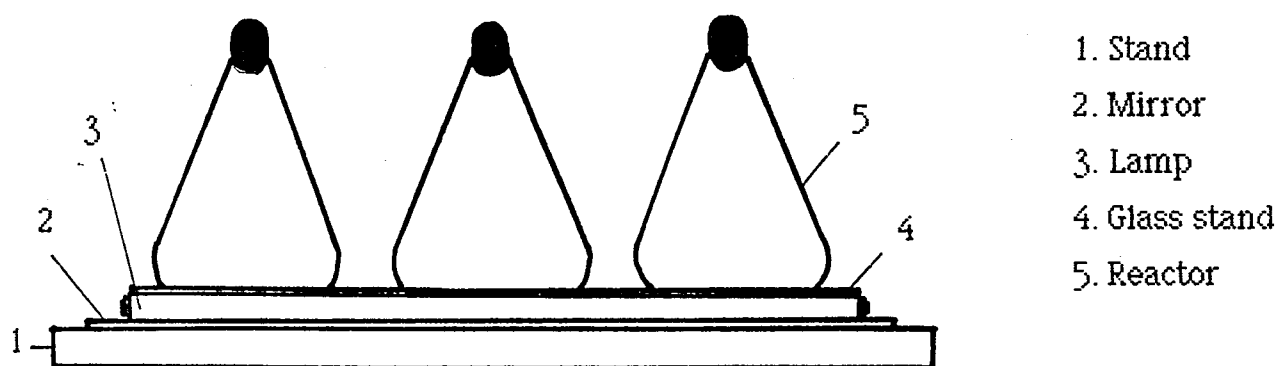

Figure 3.4. Experimental Set-up I.

Experimental Set-up II. Experimental Set-up II was consisted of one Tungstram HgV125 black light source lamp. 50 ml glass beakers were used as a reaction vessel. Reaction vessel containing sonicated TiO_2 powders in *E. coli* suspension was illuminated from one side (Figure 3.5). Mixing was provided by a magnetic stirrer. Extreme care was paid to exclude any actinometrically active light during experiments. At specific time intervals (each 10 min) sample aliquots were taken and standard plate counts were carried out.

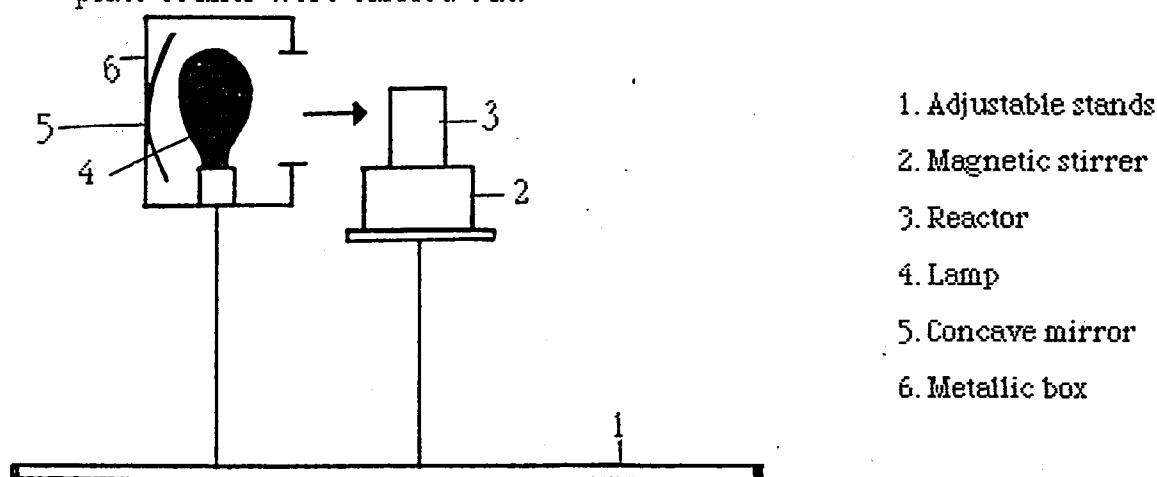
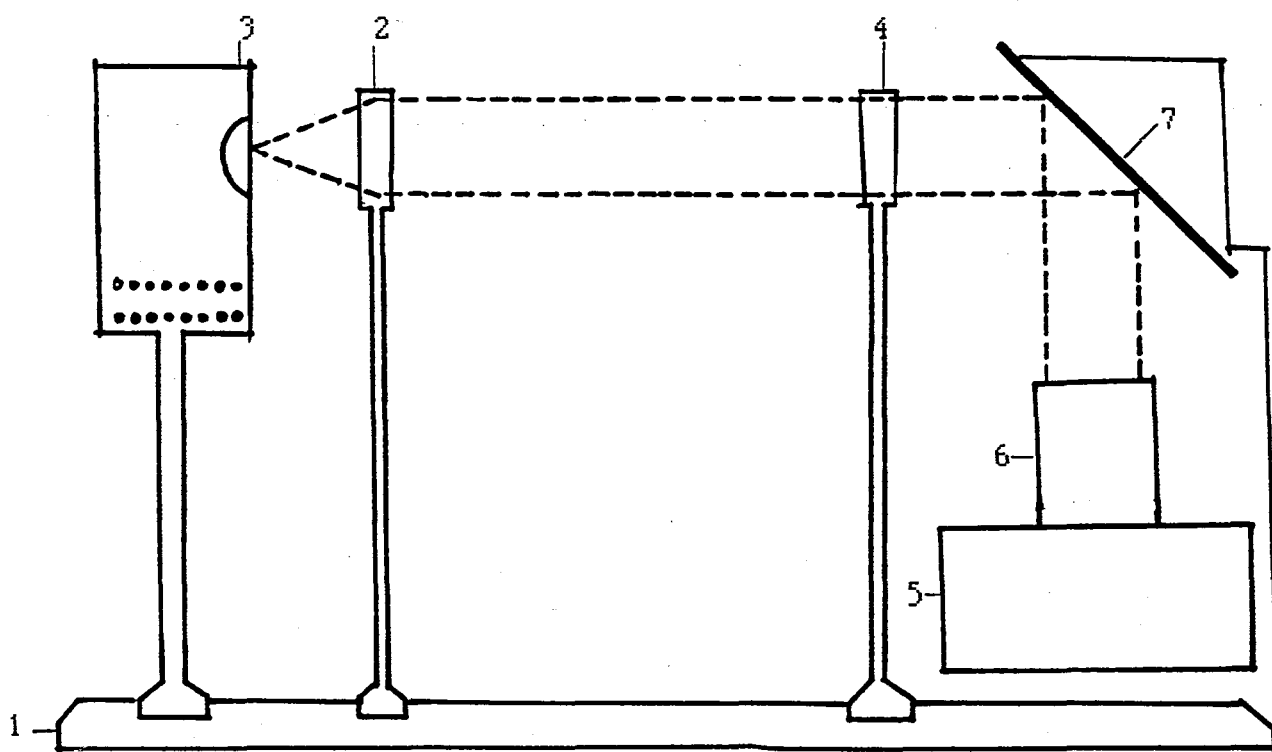

Figure 3.5. Experimental Set-up II

Experimental Set-up III. Experimental Set-up III was consisted of one medium pressure mercury lamp having the same conditions of experimental setup II. (Figure 3.6)



- | | |
|-----------------|---------------------|
| 1. bench | 5. magnetic stirrer |
| 2. lens | 6. reactor |
| 3. light source | 7. mirror |
| 4. filter | |

Figure 3.6. Experimental Set-up III

IV. RESULTS AND DISCUSSION

4.1. Results Obtained from Experimental Set-up I.

Reaction conditions: Light source 3x8W Phillips TL

Reaction mixture : TiO_2 concentration : 50mg TiO_2

E.Coli concentration: 1.0×10^3 cell/mL

in 40mL sterilized raw water

Duration : 60 min

Reactions were carried out under illumination, in dark and in the absence of TiO_2 powders. The results obtained under the above conditions are plotted on a semilog paper (Figure 4.1.)

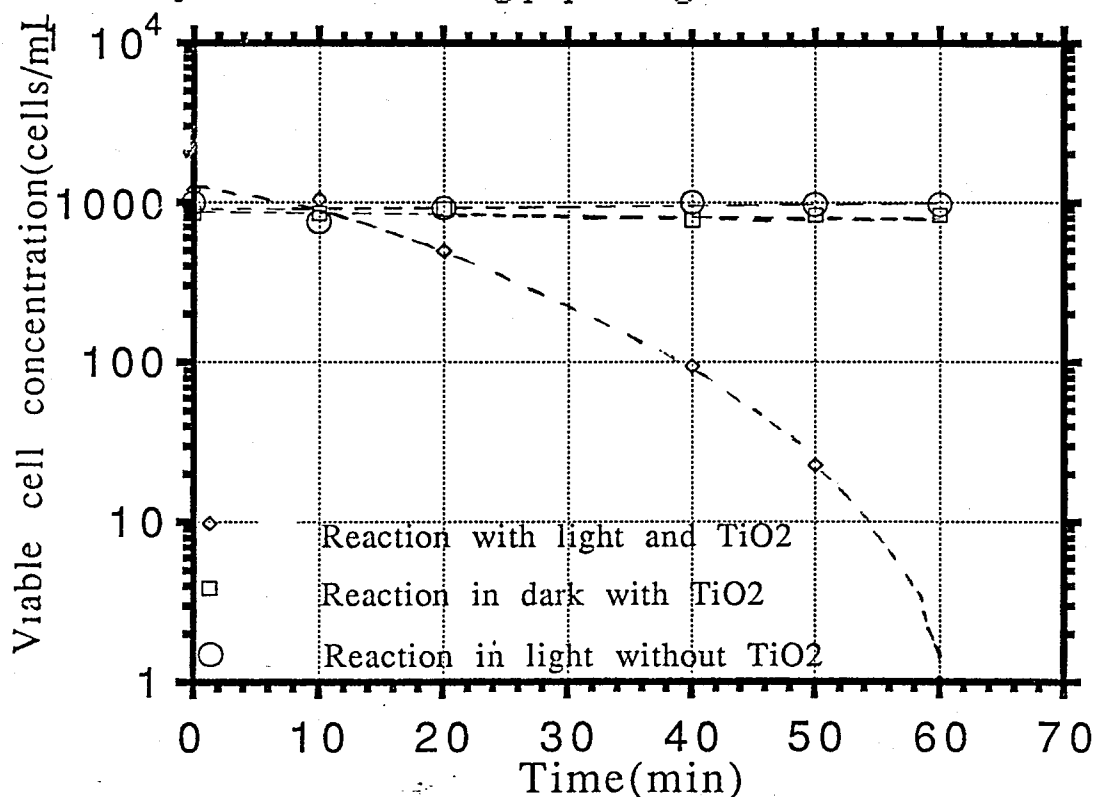

Figure 4.1. Time course of viable cell concentrations in Experimental Set-up I with 50 mg TiO_2 concentration without TiO_2 , and without illumination in 40 mL sterilized raw water.

Figure 4.1. shows the decreasing behavior of viable cell count under irradiation with the 3x8W Phillips TL lamps. The time required for bactericidal effect was found to be approximately 60 minutes.

By a control experiment, it can be concluded that there is about no bactericidal effect (<2%) of TiO_2 in the dark; (Figure 4.1. line D), and the percentage of viable cell counts in the absence of semiconductor powders was observed to be <3%; (Figure 4.1. line C).

The number of viable cells decreased gradually after "a shoulder effect" of about 10 minutes. Since in all the experiments young *E.Coli* cultures were used, at this stage the *E.Coli* cells were in a state of two about-to-divide into four. The presence of a shoulder can also be explained by the prominent effect of visible radiation radiations than in near ultraviolet radiations [31]. The emission spectrum of black light lamp is shown in Figure 3.2. The shoulder observed in Figure 4.1 may be explained by the lamp output data; since in wavelengths longer than 400 nm less than 30% of the relative energy is available.

No shoulder effect was observed in the work that was carried out by Matsunaga et al. in which an efficient mixing of *E.Coli* suspension was provided with a masterflex pump [37]. Another effective factor is that the light intensity is 10^2 fold greater than experimental set-up I. Matsunaga et al. used a light intensity about 2.6×10^{21} quanta/sec.m² whereas in this Experimental part I 1.5×10^{19} quanta/m².sec was used.

Matsunaga et al. reported that under irradiation of 2.6×10^{21} quanta/m².sec the number of viable cell decreased gradually and the sterilization was complete after 60 minutes with initial cell

concentration of 10^3 cells/mL and 1 mg TiO_2 /mL raw water (Table 4.1.) using a mercury lamp (HF 100X Iwasaki Electric Co.) [37]. In another work of the authors 20% surviving cells was observed under metal halide lamp irradiation after 60 minutes [32]. Table 4.1. shows the lethal effect of semiconductor powder (TiO_2) on *E.Coli* under various conditions.

Table 4.1. Lethal effect of semiconductor powder (TiO_2) on *E.Coli* under various conditions.

Semiconductor Powder	light source	Light intensity (quanta/ m^2 .sec)	Time (min)	Surviving ratio%	Ref.
TiO_2 /Pt	Metal halide	2.7×10^{21}	60	20	(32)
TiO_2 /Pt	Metal halide	2.7×10^{21}	120	0	(32)
TiO_2	Mercury	2.6×10^{21}	60	0	(37)
TiO_2	BL fluorescent lamp 3x8W	1.5×10^{19}	60	0	Set I
TiO_2	BL fluorescent lamp 125 W	4.0×10^{19}	50-60	0	Set II

4.2. Results obtained from Experimental Set-up II.

Reaction conditions: Light source: 1x125W Tungfram HgV

Reaction mixture : TiO_2 concentration : 50mg TiO_2

E.Coli concentration : 1.0×10^2 cells/mL
in 40mL sterilized raw water

Duration : 60 min

The reaction was carried out under illumination and the cell counts were plotted on a semi-log paper. The results obtained under the above conditions are given in Figure 4.2.

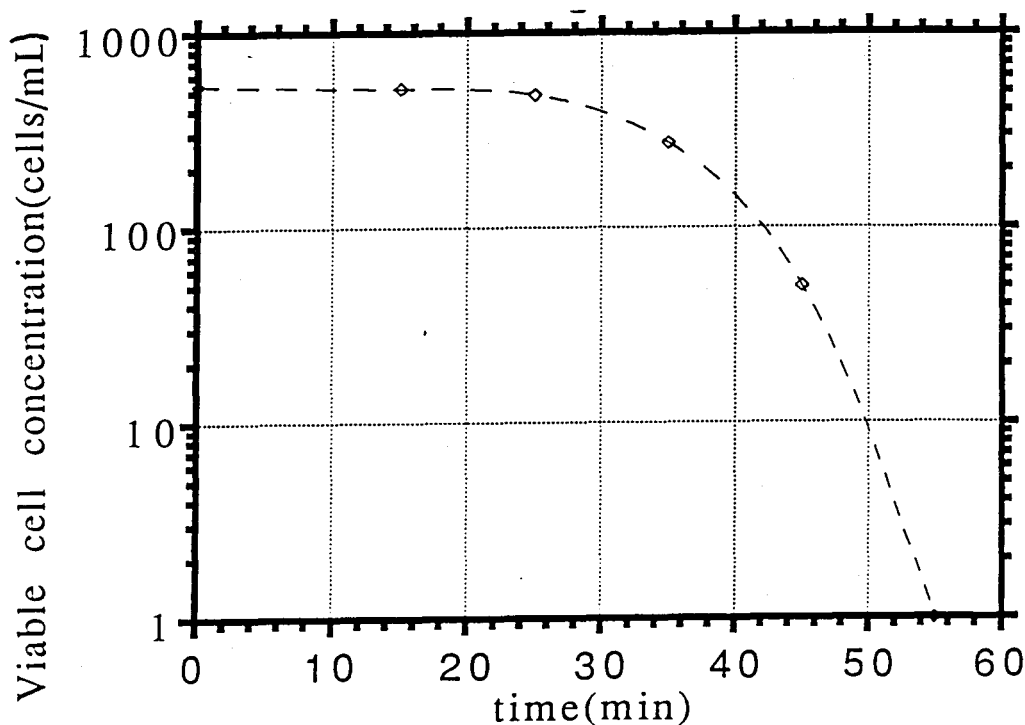

Figure 4.2. Time course of viable cell concentration in Experimental Set-up II with concentration of 50 mg TiO_2 /40 mL sterilized raw water.

Figure 4.2. shows the decreasing behavior of viable cell count under irradiation with the 1x125 Tungfram HgV black light lamp. The time required for bactericidal effect was found to be approximately between 50 and 60 minutes.

The shoulder effect was observed to be effective for 25 minutes. The same arguments are also valid for the explanation of this effect as given in the previous part 4.1. The main reason lies in the intensity of the light source. The conditions and the result of the above mentioned experiment were also given in Table 4.1.

Light irradiance was observed to be 4.0×10^{19} quanta/m².sec having a contact area of 1.1×10^{-3} m² whereas in Experimental Set up I light irradiance was observed to be 1.5×10^{19} quanta/m².sec. having a contact area of 3.3×10^{-3} m².

The initial concentrations of *E.Coli* cells was found to be effective on the sterilization time [37]. In this experimental part, initial concentration of *E.Coli* was 10^2 cells/mL. Matsunaga et al reported that under the same conditions except the light intensity (6.6×10^{20} quanta/m².sec) 10^2 cells/mL was completely sterilized after 30 minutes. This situation indicates that initial cell concentration is an effective factor on sterilization time as well as the light intensity.

4.3. Results obtained from Experimental Set-up III

Reaction conditions : One medium pressure mercury lamp

Reaction mixture : TiO₂ concentration : 50 mg TiO₂
E. coli concentration : 1.0×10^3 cells/mL
 in 40 mL sterilized raw water

Duration : 60 minutes

Reactions were carried out under illumination. The results obtained under the above conditions are given in Figure 4.3.

As can be seen from graph (Figure 4.3a) the sterilization with the medium pressure mercury lamp having a light intensity of 2.52×10^{18} quanta/sec.m² was inefficient. (The illumination area

was 16 cm^2). The wavelength of the light absorbed by the reactant should have an intensity larger than $10^{18} \text{ quanta/sec.m}^2$ [41]. In this case the irradiance was about the limiting value for the photochemical reactions. The filter used in the optical bench was cutting off radiation shorter than some critical wavelength but passing all longer wavelength radiation until far out in the infrared. The same experiment was carried out without the filter.

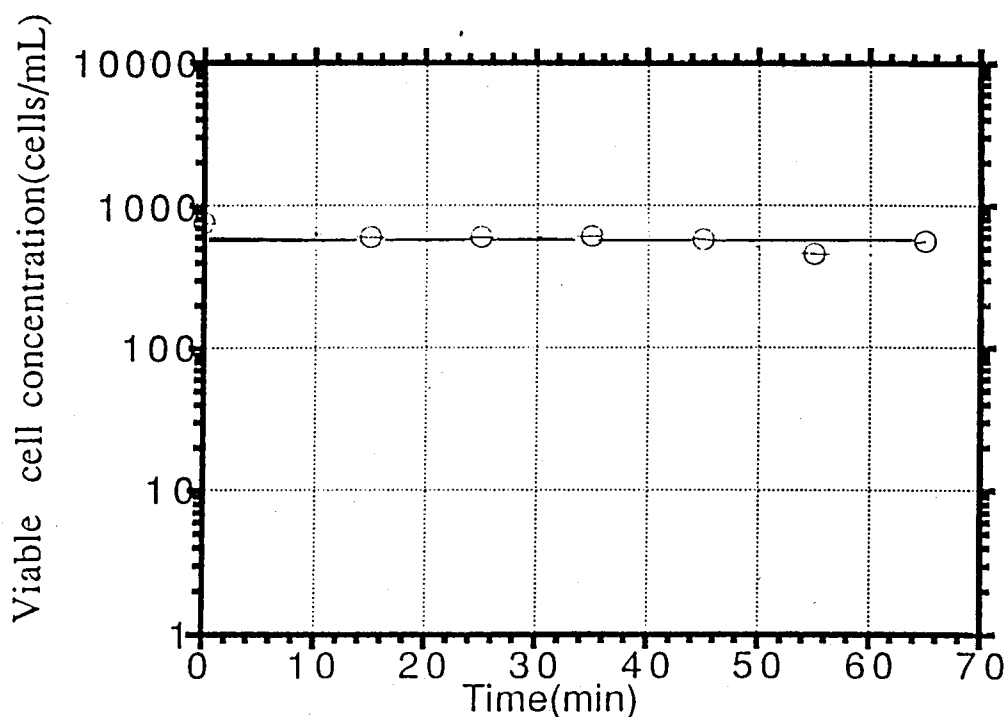

Figure 4.3a. Time course of viable cell concentrations in Experimental set-up III with concentration of $50 \text{ mg TiO}_2/40 \text{ ml}$ sterilized raw water.

The actinometric result was about $5.56 \times 10^{18} \text{ quanta/sec.m}^2$. A little difference was observed in the number of survived organisms. TiO_2 has a band gap energy of 3.2 eV which is at a wavelength of 390 nm . The relative energy output at this wavelength is very low approaching to zero. Therefore no bactericidal effect was observed. Figure 4.3b shows the results

obtained in the Experimental Set-up III using the light source without the filter.

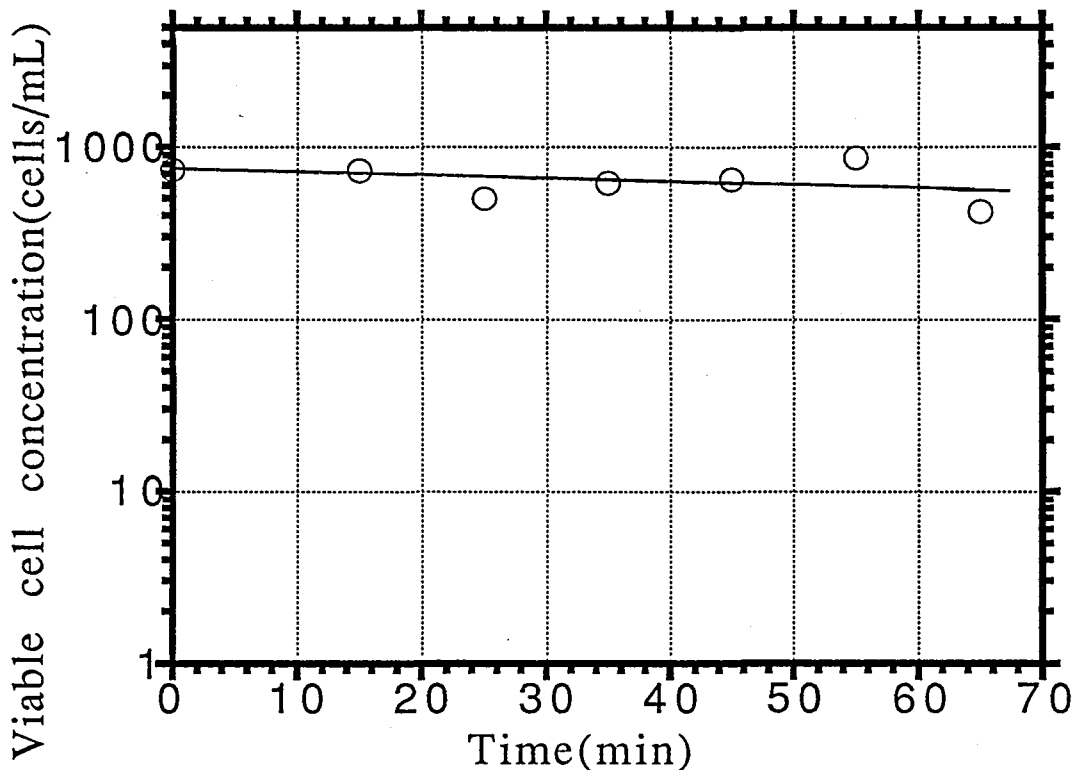

Figure 4.3b. Time course of viable cell concentration in Experimental Set-up III without the filter with concentration of 50 mg TiO_2 /40 mL sterilized raw water.

4.4. Results obtained from the effect of different TiO_2 concentrations in surviving ratio in experimental Set-up I.

Reaction conditions : Light source 3x8W Phillips TL

Reaction mixture : TiO_2 concentration : 10, 50, 100 mg TiO_2
E.Coli concentration: 1×10^3 cell/mL
 in 40 mL sterilized raw water

Duration : 60 minutes

Photochemical reactions with different concentrations of TiO_2 were carried out in 60 minutes interval. The surviving ratio versus time is plotted in Figure 4.4.

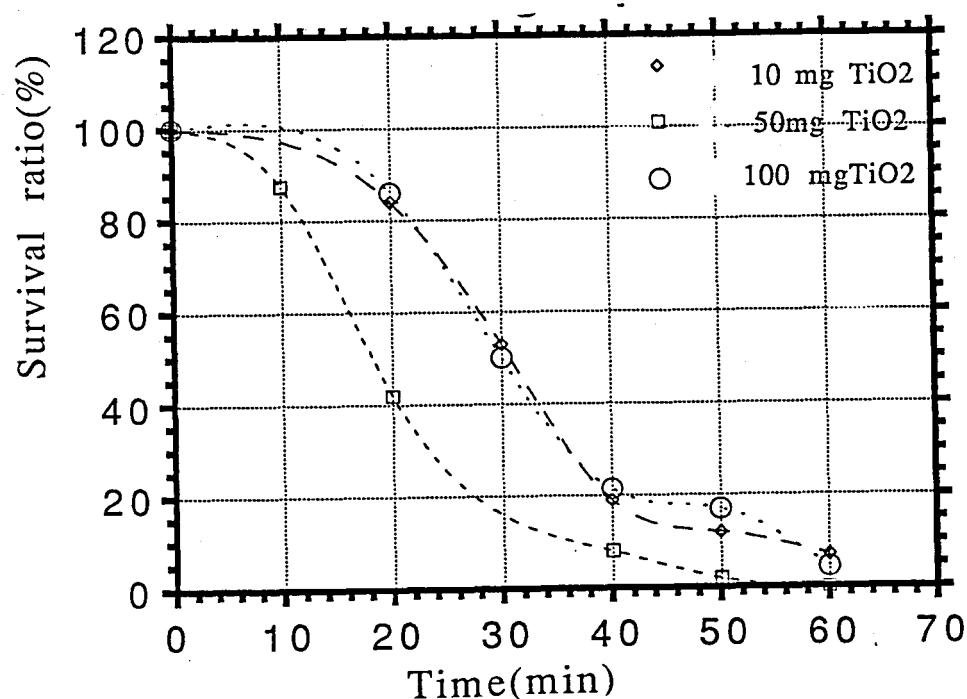

Figure 4.4. Time course of surviving ratio in Experimental set-up I with 10 mg, 50 mg, 100 mg TiO_2 concentration in 40 mL sterilized raw water.

The curves for 10 mg and 100 mg TiO_2 were almost the same having the same shoulder effect and almost the same time for the sterilization. Death of microorganisms usually follows a logarithmic curve, which becomes a straight-line graph if the logarithm of viable microorganisms is plotted against time. Such a curve means that a constant fraction of the surviving organisms is being killed per unit time. Curves of this kind never quite reach "zero organisms" [2]. For example if the concentration in a fluid is 100 cells/ml at the beginning and 90% were killed every minutes, the probability of finding one-tenth of an organism per milliliter after 3 minutes might be present. Sterility can thus be considered to be the state where the

probability of finding even a single viable organism in the total volume involved is extremely low. As can be seen from the graph (Figure 4.4), concentrations of 10 mg and 100 mg TiO_2 didn't reach "zero-organisms" in 60 minutes time interval.

In experimental set-up I 50 mg TiO_2 /40 mL sterilized raw water seems to be the optimum condition. The time required for bactericidal effect is found to be in 50 minutes. This indicates that 10 mg is a quantity too low for sterilization conditions and 100 mg is a value too high to the sterilization conditions. Increase in TiO_2 concentrations increase the opacity of the solution and causing a decrease in penetration of light through the solution.

4.5. Results obtained from the effect of different TiO_2 concentrations in surviving ratio in experimental set-up II.

Reaction conditions : Light sources : 1x125W Tungstam HgV
 Reaction mixture : TiO_2 concentration : 10 mg, 50 mg, 100 mg
 E. coli concentration: 1.0×10^2 cells/mL
 in 40 mL sterilized raw water
 Duration : 60 minutes

Photochemical reactions of different concentrations of TiO_2 were observed in 60 minutes interval. The surviving ratio versus time was plotted in Figure 4.5.

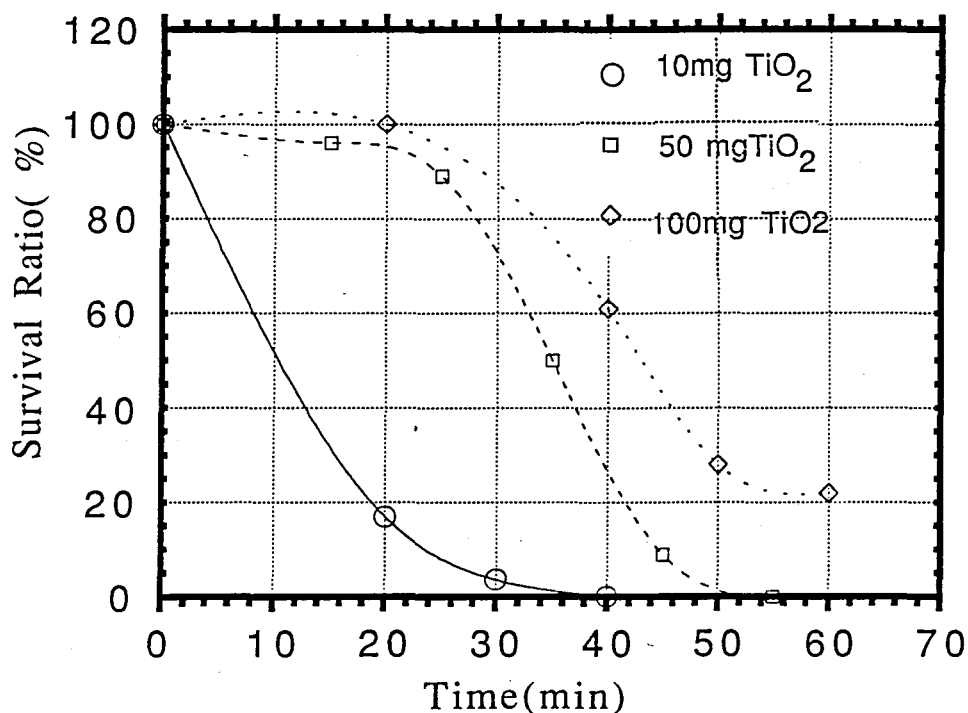

Figure 4.5. Time course of survival ratio in Experimental set-up II with 10 mg 50 mg, 100 mg TiO₂ in 40 mL sterilized raw water.

As can be seen from the graph, 10 mg TiO₂ was the optimum condition for experimental set-up II. The time required for bactericidal effect was found to be approximately between 30-40 min. interval. No shoulder effect was detected.

Although a shoulder effect was present until 20 minutes in 50 mg TiO₂ concentration the bactericidal effect was found to be between 50 and 60 minutes interval.

For 100 mg TiO₂ concentration 60 minutes was not sufficient. Opacity of the solution inhibit the light penetration and also inhibit

the oxidation of microbial cells. Same shoulder effect as 50 mg was detected for 100 mg TiO₂ concentration.

10 mg TiO₂ concentration is in the optimum range stated by Onoda et al [31]. Increasing the concentration of TiO₂ increase the bulkiness of the solution. (This is the case in 100 mg TiO₂ concentration).

The light used in both experiments have the same emission spectrum with difference in their intensities. Experimental Set I. have a greater value for the energy absorbed by the system. The sets were illuminated and mixed in different manners. Set I. were illuminated from the bottom having an area of 33.16 cm². Set II. were illuminated from one side and having an area of 11.25 cm² whereas a good mixing was provided for Exp. Set II. Settling of TiO₂ in Set I in higher concentrations (although sonication was provided before the experiment and shaking every 10 minutes during the experimental) couldn't be prevented. Settling of TiO₂ was decreasing the contact areas with *E.Coli* cells and inhibiting the light penetration. This problem was absent for Exp. Set II.

4.6. Effect of different TiO₂ concentration on surviving ratio

4.6.1. Experimental Set-up I.

Reaction conditions : Light sources 3x8W BL fluorescent lamp.
 Reaction mixture : 10,20,30,40,50,60,100 mg TiO₂ per
E. Coli concentration: 10³ cells/mL
 in 40 mL sterilized raw water
 Duration : 30 minutes

Table 4.2. Effect of different TiO_2 concentration on surviving ratio in Experimental Set I (0-30min)

TiO_2 concentration per 40 mL Raw Water	Initial cell concentration	t=30 min survival ratio of <i>E. coli</i> (%)
10 mg	1×10^3	50
20 mg	1×10^3	40
30 mg	1×10^3	40
40 mg	1×10^3	20
50 mg	1×10^3	16
60 mg	1×10^3	40
100 mg	1×10^3	>50

As can be seen from the table above the optimum conditions for the photochemical effect of TiO_2 can be observed at a range between 40 and 50 mg TiO_2 /40 mL sterilized raw water. The other concentrations were inefficient for the oxidation of microbial cells. This conclusion shows an agreement with the study of Matsunaga et al. where 1 mg/mL Raw Water water was used for the sterilization. In the study of photocatalytic bactericidal effect of powdered TiO_2 on *Streptococcus Mutans*, Onoda et al. mentioned that the optimum concentrations of TiO_2 powders were in a range of 0.01 and 0.1 wt. %. The 0.01 wt % disagree, with the table 4.1, because decreasing the concentration of TiO_2 to less than mg/mL ratio increase the surviving ratio. The second value 0.1 wt % agree with the table above [31, 37].

4.6.2. Experimental Set-up II.

Reaction conditions : Light sources: One Tungfram BL fluorescent lamp.

Reaction mixture : TiO_2 concentration: 10, 40, 50, 100 mg TiO_2

E. coli concentration: 10^2 cells/mL

in 40 mL sterilized raw water

Duration : 30 minutes

Table 4.3. Effect of different TiO_2 concentration on surviving ratio in Experimental Set II (0-30 min)

TiO_2 concentration per 40 mL Raw Water	Initial cell concentration	t=30 min survival ratio of <i>E. coli</i> (%)
10 mg	1×10^2	4
40 mg	1×10^2	18
50 mg	1×10^2	70
100 mg	1×10^2	85

In the case of Experimental Set. II the optimum values were obtained at a concentration range of 10-40 mg TiO_2 (Table 4.3). Although the bactericidal effect is observed with 50 mg TiO_2 concentration in 60 minutes interval, 1 mg/mL concentration is more efficient. 100 mg TiO_2 concentration is too bulky for this type of experimental set.

4.7. Effect of initial *E.Coli* concentration on surviving ratio

Reaction conditions: Light source: 3x8W BL fluorescent lamp

Reaction mixture : TiO₂ concentration : Table 4.4

E.Coli concentration: Table 4.4

in 40 mL sterilized raw water

Duration : 30 min

Table 4.4. Effect of initial cell concentration on surviving ratio in time fix

TiO ₂ concentration per 40 mL Raw Water	Initial cell concentration	t=30 min survival ratio of <i>E.Coli</i> (%)
10 mg	6.4×10^4	62.5
	1.0×10^3	50
20 mg	1.0×10^3	40
	8×10^2	10
	4×10^2	5
40 mg	1×10^3	20
	4×10^2	11.25
100 mg	6.4×10^4	54
	1.0×10^3	50

As can be shown from Table 4.4 decreasing the values of *E.Coli* in the solution increase the bactericidal effect in other words

decreases the value of surviving ratio. For 20 and 40 mg TiO_2 concentration, there is a linear relationship between E.Coli concentration and surviving ration. In the study of Matsunaga the system was efficient for complete sterilization when 10^2 and 10^3 cells were used, whereas the surviving ratio for 10^4 cells/mL and 10^5 cells/mL were 32% and 84% respectively for 30 minutes under irradiation of 6.6×10^{20} quanta/sec.m² [37]. The system was not so efficient as 20 mg and 40 mg TiO_2 for values of 10 mg and 100 mg TiO_2 /40 mL raw water.

4.8. Results for the actinometric measurements

In order to find the number of photons per second per square meter absorbed by the solution in the cells the actinometric procedure stated in section 3.2.2. was used. For a constant irradiation the lamp was warmed for 30 minutes before the actinometric measurement. The number of quanta absorbed by the actinometer is stated below by this formula [42]:

$$\sum n_{\text{Fe}^{+2}} = \frac{6.023 \times 10^{20} \times V_1 \times V_3 \times \text{O.D.}}{V_2 \times L \times E}$$

V_1 = The volume of actinometer solution, irradiated (mL)

V_2 = The volume of aliquot taken for analysis (mL)

V_3 = The final volume to which the aliquot V_2 is diluted (mL)

E = The molar extinction coefficient of Fe^{+2} complex, 1.11×10^4 L mole⁻¹ cm⁻¹.

O.D.= the measured "difference optical density" at 510 nm.

L = the path length of spectrophotometer cell (cm).

The number of quanta absorbed by the actinometer n_{abs} is

$$\sum n_{\text{abs}} = \frac{\sum n_{\text{Fe}^{+2}}}{\phi_{\lambda}}$$

ϕ_{λ} = the quantum yield for the Fe^{+2} formation at 300-400 nm, 1.24

The number of quanta per unit time per unit area n_{abs} is

$$n_{\text{abs}} = \frac{\sum n_{\text{abs}}}{t.A}$$

The results of the actinometric study for the three different reactors are given in Table 4.5.

Table 4.5. Actinometric results

$V_1 = 40 \text{ mL}$	$L = 1 \text{ cm}$
$V_2 = 2 \text{ mL}$	$E = 1.11 \times 10^4 \text{ L mole}^{-1} \text{ cm}^{-1}$
$V_3 = 50 \text{ mL}$	$\phi_{\lambda} = 1.24$

Sets	time (sec)	Area m^2	O.D	Light source intensity (quanta/ $\text{m}^2 \cdot \text{sec}$.)
Experimental Set-up I	300	3.3×10^{-3}	0.34	1.50×10^{19}
Experimental Set-up II	300	1.1×10^{-3}	0.3	3.97×10^{19}
Experimental Set-up III	360	1.6×10^{-3}	0.073	5.53×10^{18}
Experimental Set-up III (filter)	360	1.6×10^{-3}	0.033	2.50×10^{18}

4.9. Effect of Temperature, pH. and others:

No change was observed in the pH of the solution during the experiment. The pH-value was in the range of 7.1-7.2. A difference of 5°C was observed between initial and final temperature values. At the beginning of the experiment preliminary studies were carried out with phosphate buffer for control purposes. Since the study was objected to sterilize raw water, the experiments with sterilized raw water was taken into consideration.

Another factor that must be calculated is the transmission of the beaker used. The beaker was made of glass. Ordinary window glass in thickness of 2mm or more is practically opaque to ultraviolet of wavelength shorter than 3000 nm. The glass has 90% transmission between 370-400 nm, for the first two sets the irradiation passes through the glass then contact the solution is >90% at this wavelength. Therefore little effect is observed by the transmission of the glass. For the third experimental set the light is directly absorbed by the solution.

V. CONCLUSION AND RECOMMENDATIONS

The photochemical sterilization of *Escherichia Coli* cells was achieved in 60 minutes under the irradiation of two different fluorescent lamps. One set-up was consisted of 3x8W BL fluorescent lamps placed horizontally parallel to each other permitting a suitable design for continuous flow of thin layer of water. The other set-up was consisted of one Tungram HgV 125 W black light lamp placed in upright position permitting a suitable design for continuous flow of water in a coiled glass reactor. *E.Coli* concentration was 10^3 cells/mL indicative of probable contamination level in untreated drinking water supplies. The effective TiO_2 concentrations were determined and 1mg/mL was found to be optimum for Experimental Set-up I and 0.1-1.0 mg/mL for Experimental Set-up II although slight variations did exist between the lamps. Since photochemical sterilization was not reported to be significant for *E.Coli* only, the following argument was carried out.

The cell wall composition of various microorganisms was explained as an effected factor in the sterilization by semiconductor powders [32]. Gram positive bacteria is surrounded by a cell wall, typically 250 Å wide, composed of peptidoglycan and teichoic acid, gram-negative bacteria have a more complex cell wall. The plasma membrane in surrounded by a 30 Å wide peptido glycan wall which in turn is covered by an 80 Å outer membrane composed of protein, lipid and lipo polysaccharide. The green algae has even more thicker cell wall mainly composed of polysacchārides and peptin, the results of the study on these organisms are given in the following table for comparison.

Table 5.1: Sterilization of various microorganisms by semiconductor powder (TiO_2/pt) [32].

Microorganism	Time	Surviving ratio %
Gram positive bacteria (<i>Lactobacillus acidophilus</i>)	60	0
Gram negative (<i>Escherichia coli</i>)	60	20
Yeast (<i>Saccharomyces cerevisiae</i>)	60	54
Green algae (<i>Chlorella vulgaris</i>)	60	85

It can be concluded that sterilization time under specified conditions will not be sufficient enough to state the sterilization of raw water samples if *E.Coli* is used as an indicator organism especially nowadays since an on going argument on viruses being surviving under traditional sterilization techniques is popular!

RECOMMENDATIONS

It can be recommended that further research will be of interest; if;

1. Immobilization of TiO_2 powders with certain surface characteristics can be achieved.
2. Differentiation between doped and undoped TiO_2 forms can be studied.
3. Continuous sterilization system can be designed under solar radiation for practical purposes.

APPENDIX I.

Streaking technique:[40]

1. Sterilize a platinum transfer loop by flaming until it glows light red. Allow it to cool in air or stab it into sterile agar medium.
2. Use the cooled loop to pick up the bacteria. Touch the loop to a single well isolated bacterial colony growing on the surface of solid medium.
3. Streak the bacteria adhering to the loop onto a segment of a plate containing agar medium. Sterilize the loop by flaming and cooling by stabbing it into a region of the agar medium that is free of bacterial cells. Pass the loop once across one end of primary streak and spread the bacteria that adhere to the loop into a fresh region of the agar medium.
4. Sterilize and cool the loop again and streak from one end of the secondary streak.
5. Repeat step 3 twice more, serially.
6. Replace the lid on the plate. Incubate it in an inverted position at 37°C for 26 hours. Well spreaded colonies would be visible in the area of final streak.

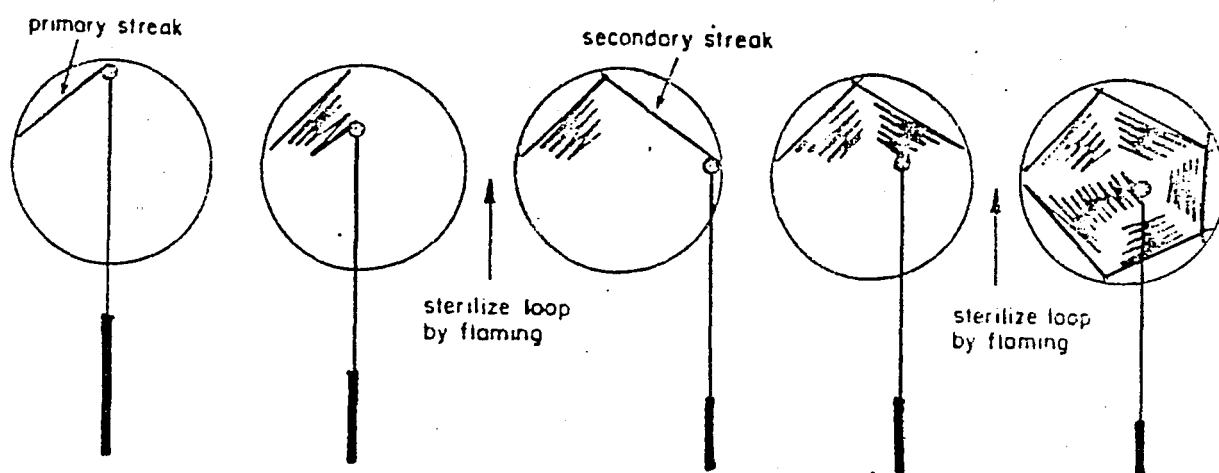

Spreading technique:[40]

1. Transfer bacteria from a liquid culture to a tube of volume of 1 mL containing required sterile saline. Vortex to disperse any clumps of bacteria.
2. Transfer the required volume from tube 1 for the desired dilutions.
3. Repeat step 2 serially two or three times.
4. Spot an aliquot of 50 mL of each dilution in the center of a plate containing hardened agar medium. Spread the cells over the entire surface of the medium, by moving a sterile bent glass rod back and forth gently over the agar surface and at the same time, rotating the plate by the hand. The glass spreader can be sterilized by dipping it into a beaker containing 95% ethanol and then holding it in the flame of a bunsen burner to ignite the ethanol. The spreader should then be cooled first in air and then by touching the surface of a plate of sterile agar medium.

APPENDIX II.

Multiple-tube fermentation:

This test progresses through three distinct steps; The presumptive test, the confirmed test and the completed test. The second and the third test increase the certainty that positive results obtained in the presumptive test are due to coliform bacteria and not other kinds of bacteria. The completed test is used to establish definitively the presence of coliform bacteria for quality control purposes. Bacteriological testing of most public water supplies stops after confirmed test. The presumptive test is the first step of the analysis. The sample is poured into lactose or lauryl tryptose broth and an inverted vial. The samples are incubated for 24 h, checked in the water, gas will begin to form in the inverted vials within 48 h period; this indicates a positive sample. If no gas forms, the sample is negative. All positive samples undergo the confirmed test.

The confirmed test is more selective for coliform bacteria. Cultures from the presumptive step are transferred to brilliant green lactose bile broth and incubated. If no gas is produced after 48 hrs of incubation, the test is negative and no coliform bacteria are present. If gas is produced, the test is positive indicating the presence of coliform bacteria.

Positive samples then undergo the completed test. The sample is placed on aneosin methylene blue (EMB) agar plate and incubated. A small portion of coliform colonies formed is transferred to a nutrient agar slant and incubated for 24 hrs. A second portion is transferred to a lauryl tryptose broth and incubated for 24 to 48 h. The completed test is positive if (i) gas is produced in the lauryl tryptose broth and (ii) red-stained, non spore forming, rod-shaped bacteria are found. If no gas is produced in the lauryl tryptose broth, chain-like cocci or blue-stained, rod-shaped bacteria are found on the agar.

Membrane filter technique:

The membrane filter method of coliform testing begins by filtering a measured volume of sample under a vacuum through a membrane filter. The filter is then placed in a sterile container and incubated in contact with a selective culture media. A coliform bacteria colony will develop at each point on the filter where a viable coliform bacteria was left during filtration. After an incubation period the number of colonies per measured volume is counted.

Coliforms are distinguished from other groups of organisms by their possession of the enzyme β -Galactosidase which is necessary for splitting the lactose contained in the Endo medium. In addition, coliform lack the enzyme cytochrome oxidase (CO). Knowledge of these two features, the medium used contains an agent which verifies the presence of β -Galactosidase in the suspect colonies; and NN-dimethyl-p-phenyldiamine which verifies CO activity.

Standard Plate Count:

The standard plate count is the only practical way to estimate the total bacterial population of waters. The test determines the total bacteria in a sample that will grow under the influence of the selected media.

This test is performed by placing diluted water samples on plate-count agar. The samples are incubated for 24 hour at 37°C. The bacteria colonies that grow on the agar are then counted using bacteria counting equipment.

VI. REFERENCES

1. Ollis, F.D and J. E. Bailey, Biochemical Engineering Fundamentals 2nd ed., McGraw Hill, Singapore, 1986.
2. Nester W.E, Robert C.E., Pearsall N.N., Mccarthy B.J. Microbiology 2nd ed., Holt, Rinehart and Winston, 1978.
3. Metcalf & Eddy Wastewater Engineering Treatment and Disposal, 2nd ed., Mc Graw Hill, New Delhi, 1989.
4. Pir, S.J. Microbe and Cell Cultivation 1st ed., William Clowes Limited, London, 1975.
5. Commite Report "Disinfection" Journal American Water Works Association 1982 pg 376-380.
6. Arnold et al. Photochemistry an Introduction 1st ed., Academic Press, Inc., Newyork 1974.
7. Wayne R.P. Photochemistry 1st ed., Butterworth & Co (Publishers) Ltd. England 1970.
8. Bard A.J., "Photoelectrochemistry", Science, Vol. 207 pp. 139-145, January 1980.
9. Hintz, H.J. "Some Chemical and Electronic Considerations of Solid State Semiconductor Crystals". Journal of Chemical Education Vol.63 No:11, 1986.
10. Bard, A.J. "Photoelectrochemistry and Heterogeneous Photocatalysis at semiconductors", Journal of Photochemistry, Vol.10, pp.59-75, 1979.
11. Davis, K.A. "Titanium Dioxide" Journal of Chemical Education, Volume 59, No:2, 1982, pp. 158-159.
12. Roberts, L.K., et al., Encyclopedia of minerals, New York, Van Nastrand Co., 1974.
13. Mellor, J.W., A comprehensive Treatise on Inorganic and Theoretical Chemistry, Vol.3, p.35-60, London: Longmans, Green and Co., 1952.

14. Johnson D.J., Disinfection water and wastewater, 2nd ed., Ann Arbor Science Publishers Inc., Michigan, 1977.
15. Wolf, R.L., et al., "Disinfection of Model Indicator Organisms in a Drinking Water Pilot Plant by using Peroxone". Applied Environmental Microbiology, Vol. 55, No:9 pp.2230-2235, 1989.
16. Literature Rewiew "Disinfection Research" Journal Water Pollution Control Federation, Vol.63 No:4, pp 416-423.
17. Wisterich Lechtman, Microbiology, 3rd ed., McMillan Publishing Co. Inc. New York.
18. Harris et al., "Ultraviolet Inactivation of Selected Bacteria and Viruses With Photoreactivation of the Bacteria". Water Resources Vol. 21, pp.687-692, 1987.
19. Jagger J. Introduction to research in UV Photobiology. Prentice Hall Englewood Cliffs, N.J., 1967.
20. Murphys, W.R.; Veerkamp, R.F.; Leland, T.W. Journal of Catalysis , Vol.43, pp.304, 1976.
21. Juliet, F. et al. Faraday Symp. Chemical Society Vol.7, No:57, 1973.
22. Frank, S.N. and A.J., Bard. "Heterogeneous photocatalytic oxidation of cyanide and sulfite in aqueus solution at semiconductor powders". Journal of American Chemical Society; Vol.81, pp.1484-1488, 1977.
23. Frank, S.W.; Bard, A. Journal of Physical Chemistry, Vol.81, pp.1484, 1977.
24. Kraeutter, B. and A.J., Bard "Heterogeneous photocatalytic synthesis of methane from acetic acid-new Kolbe reaction pathway" Journal of American Chemical Society; Vol.100; p. 2239-2240, 1978.
25. Krauetler, B.; Bard, A.J. Journal of American Chemical Society, Vol.100, pp.5985, 1978.
26. Ausloos, P.; Rebbert, R.F.; Glasgow, L. J. Res. Nat. Bur. Stand. Vol.82, No:1, 1977.
27. Filby, W.G.; Mintos, M.; Gustern, H. Ber Bunsenges, Physical Chemistry Vol.85, pp. 189, 1981.

28. Corey, J.H.; Lawrence, J.; Tosine H.M. Bull, Environmental Contamination Toxicology, Vol.16, pp.697, 1976.
29. Ollis, D.F "Contaminants degradation in water" Environmental Science and Technology Vol.19; pp.480-484, 1985.
30. Mathews W.R., Water Resources Vol:20, No:5, pp.569-578, 1986.
31. Onoda et Al. "Photocatalytic Bactericidal Effect of Powdered TiO₂ on Streptococcus Mutans" Denki Kagaku Vol. 56, No.12, pp. 1108-1109 1988.
32. Matsunaga, T., R. Tomoda, T.Nakajima, and H.Wake "Photoelectrochemical sterilization of microbial cells by semiconductor powders". FEMS Microbial letters Vol.29, pp.211-214, 1985.
33. Matsunaga et al. "Detection of Microbial Cells by Cyclic Voltammetry" Analytical Chemistry Vol 56, pp. 798-801, 1984.
34. Matsunaga et al "Selective Determination of Microbial Cells By Graphite Electrode Modified with Absorbed 4, 4'-Bipyridine" Analytica Chimica Acta Vol.159, pp.87-94, 1984.
35. Matsunaga et al "Electrochemical Sterilization of Microbial Cells" Bioelectrochem. Bioenerg., Vol.13, pp.393-400, 1984.
36. Matsunaga et Al "Electrochemical Classification of Gram-Negative and Gram-Positive Bacteria" Applied and Environmental Microbiology, Vol.50, No.2, pp.238-242,1985.
37. Matsunaga et. al., "Continuous-Sterilization System That Uses Photosemiconductor Powders" Applied and Environmental Microbiology, Vol.54, No:6, pp.1330-1333, 1988.
38. Standart Methods for the Examination of Water and Waste Waters, APHA-AWWA-WPCF, 1985.
39. Sambrook. Fritsch. Maniatis A laboratory Manual, Molecular Cloning Cold Spring Harbor Laboratory Press.
40. Koller, L.R., Ultraviolet Radiation, 2nd ed., John Wiley and Sons, 1965.

41. De Mayo, P. and H. Shizuka, "Measurements of Reaction Quantum Yields" Chapter 4.
42. Bekbölet M., Y.Inel, "Calibration of Quantum Yield (QYR 15) Using Potassium Ferrioxalate Actinometer" Research Papers, Boğaziçi University.