

ON SUFFIXHOOD AND VERBALNESS:

A MIRROR THEORETIC APPROACH

İSA KEREM BAYIRLI

BOĞAZİÇİ UNIVERSITY

2012

ON SUFFIXHOOD AND VERBALNESS:

A MIRROR THEORETIC APPROACH

Thesis submitted to

Institute for Graduate Studies in the Social Sciences

in partial fulfillment of the requirements for the degree of

Master of Arts

in

Linguistics

by

İsa Kerem Bayırlı

Boğaziçi University

2012

## Thesis Abstract

İsa Kerem Bayırlı, “On Suffixhood and Verbalness: A Mirror Theoretic Approach”

In this thesis, I argue that suffixal and verbal status of a grammatical object can be predicted from its syntactic position within the framework of the Mirror Theoretic syntax of Brody (2003).

I first show that in Turkish there is a constraint that dictates that the morpheme syntactically right above a verbal item be suffixed to this verbal item, which I dub V-X. I argue that X-bar Theory is not well-suited to capture this observation of suffixhood as a syntax-related phenomenon. I show that, in an antilexicalist implementation, the Mirror Theory of Brody (2003) can capture V-X as a reflex of syntax, relating it to the inability of verbal items to show phrasal behavior. I argue that this follows from the fact that verbal items can only occupy a complement position (one of the two logically possible positions) in Mirror Theoretic syntax. I present evidence from Basque, Japanese, Hindi and English to show that V-X is a valid constraint in these languages and that this is correlated with the fact that verbal items cannot show phrasal behavior in these languages.

I, then, argue that, in direct opposition to verbal items, two non-verbal items (nouns and non-verbal participles) always show phrasal behavior in Turkish. I present evidence from earlier works, indicating that the inflection on non-verbal items is always phrasal (and not suffixal) and that head-movement analysis of noun incorporation in line with Baker (1988) is not the right analysis for Turkish. With this, I argue that non-verbal items can only occupy the other position (i.e. the specifier position) in Mirror Theoretic syntax. I present further evidence from Basque, Japanese, Hindi and English, indicating that the claim that the non-verbal elements are always phrasal objects has cross-linguistic validity. I show that, with a few exceptions, in these languages, too, nominal inflection is phrasal inflection and that head-movement of bare objects is not the right analysis in the context of noun incorporation.

Lastly, I outline a theory of lexical features where the [+/- verbal] and [+/- suffix] features are replaced by features that indicate what syntactic position an object may occupy in Mirror Theoretic syntax.

## Tez Özeti

### İsa Kerem Bayırlı, “(Öbekselsel Olmayan) Soneklere ve Eylem Benzeri Yapılara Ayna Kuramı’na Dayanan bir Yaklaşım”

Bu tezde, dilbilgisel bir nesnenin “(öbekselsel olmayan) sonek” ve “eylem ve eylem-benzeri” olma durumunun, bu nesnenin Ayna Teorisi’nin öngördüğü bir sözdizim yapısındaki konumuna bakılarak tahmin edilebileceğini iddia ediyorum.

İlk olarak, Türkçe’de, eylem ve eylem-benzeri bir ögenin sözdizimsel olarak hemen üzerindeki bir biçimbirim ögesinin, bu eylem ve eylem-benzeri ögeyi (öbekselsel olmayan) bir sonek olarak takip etmesini zorunlu kılan bir kısıtlamanın var olduğunu gösteriyorum ve buna E-X adını veriyorum. Daha sonra Aşamalı X Kuramı’nın bu gözlemi sözdizimin doğrudan bir sonucu olarak açıklayabilmek için uygun olmadığını öne sürüyorum. Sözlükçe’deki biçimbirimsel bilgilere dayanmayan bir uyarlamada, Brody’nin Ayna Kuramı’nın (Brody, 2003), E-X’i, son tahlilde eylem ve eylem-benzeri ögelerin öbekselsel davranış gösterememelerine dayandırarak, sözdizimin doğrudan bir sonucu olarak açıklayabileceğini gösteriyorum. Bunun da eylem ve eylem benzeri ögelerin, Ayna Kuramı’nın öngördüğü sözdizim yapılarındaki iki olası konumdan biri olan tümleş konumunda bulunmalarından kaynakladığını iddia ediyorum. Baskça, Japonca, Hintçe ve İngilizce dillerinden bulgular göstererek E-X kısıtlamasının bu dillerde de geçerli olduğunu ve bunun bu dillerdeki eylem ve eylem benzeri ögelerin öbekselsel davranış gösterememelerinin bir sonucu olduğunu savunuyorum.

Daha sonra, eylem ve eylem-benzeri ögelerin tam aksine, eylem-benzeri olmayan iki ögenin (yani adların ve ortaçların) her zaman öbekselsel davranış gösterdiklerini iddia ediyorum. Bu eylem ve eylem-benzeri olmayan ögeleri takip eden soneklerin, öbekselsel sonekler olduklarını ve Türkçe’deki ad geçişim yapılarının Baker (1988)’de iddia edildiği gibi baştan başa hareket olarak incelenmesinin doğru olamayacağını gösteren önceki çalışmalardan bulgular sunuyorum. Bununla da, eylem ve eylem benzeri olmayan ögelerin, Ayna Kuramı’nın öngördüğü sözdizim yapılarındaki diğer konumda (yani sadece niteliyici konumunda) bulunabileceklerini iddia ediyorum. Yine, Baskça, Japonca, Hintçe ve İngilizce’den eylem ve eylem-benzeri olmayan ögelerin her zaman öbekselsel ögeler olduğunu gösteren bulgular sunarak, tezimin başka diller için de geçerli olduğunu gösteriyorum. Bu dillerde de ad üzerindeki soneklerin öbekselsel olduğunu ve başın hareketine dayalı ad geçişim yapıları incelemesinin, takısız nesnelere doğru incelemesi olmadığını gösteriyorum.

Son olarak da, [+/- eylem] ya da [+/- (öbekselsel olmayan) sonek] gibi özelliklerin, bir sözlükçe ögesinin Ayna Kuramı’nın öngördüğü sözdizim yapısındaki hangi konumu alacağını gösteren özellikler ile değiştirildiği bir sözlükçe kuramının ana hatlarını çiziyorum.

## ACKNOWLEDGEMENTS

It has been a thrilling experience for me to be involved in an attempt to understand an aspect of the Nature. I am truly thankful to everyone who made this possible for me.

I would like to express my sincere thanks to my advisors: Meltem Keleşir and Markus Pöchtrager. Ever since our reading sessions, Meltem Keleşir has made a great effort to help me turn ‘some ideas’ into hypotheses that are worth pursuing. Together with excellent supervision, she gave me the freedom to play with ideas and to try, fail and try again. Were this not the case, I could not be productive and happy. The positive aspects of this thesis owe a lot to her. Thank you! I believe that I started feeling more like ‘a linguist’ after I was introduced by Markus Pöchtrager to methodological debates between theories of phonology. Observing the kind of questions that he asks and the kind of answers that he favors immensely influenced my own way of thinking about language and will probably continue to do so. I hope I will do whatever I do in the future as seriously and joyfully as he does phonology. Thank you!

My committee members were great people. The origins of many ideas in the thesis can be traced back to the morphology class that Aslı Göksel taught. She helped me at times when every claim that I made was chaotic and she taught me not to be afraid of following the consequences of an idea. The effects of this are pretty much observable in the thesis. It is thanks to Martina Gračanin Yüksek that you are reading this acknowledgements part. When I was an undergraduate student on my way to become an English teacher, it was her syntax class that made me realize that I could do something more interesting and fun with my life and I decided to be involved in theoretical linguistics. I am very glad that I did so. In addition to that, she helped me immensely during my thesis writing period so that I could figure out what my claims (actually) were and how I should pursue my questions. The semantics class that Yılmaz Kılıçaslan taught is among the memorable parts of my MA education. Especially the times when we would talk about problems at the philosophy/semantics border were truly breathtaking. He also told me a lot about how my claims looked from “outside” although he actually was very much from “inside”. Thank you all very much!

I am very thankful to Balkız Öztürk for introducing me to minimalist reasoning (among other things), to John Bolender for showing me that linguistics can be interesting in more than one way, to David Adger for introducing me to Mirror Theory and giving me the courage to implement it to my own problems and to Richard Kayne for simply taking me seriously even at times when I knew so little about linguistics. My thanks also go to Eser Erguvanlı-Taylan, Cem Bozşahin, Deniz Zeyrek and Şukriye Ruhi for being part of my journey in linguistics.

I would also like to thank my fellow students: Ömer Demirok, Bilge Palaz, Treysi Terziyan, Yağmur Sağ and Aslı Özbek. It has always been great to spend time with them. It has always been great to share linguistic jokes that no one else can understand. I hope that life will find a way to bring us closer again. Ömer needs a special mention here as he has been the one who helped me keep my interest in linguistics alive with numerous interesting discussions.

My thanks also go to my friends from non-linguistic parts of the world: Gökhan Doğru, Gökhan Fırat and Cuma Köygülü. I have always enjoyed spending time with them. I have enjoyed our discussion about possible consequences of linguistic theory for this and that. They actually listened and responded to my

comments about some claims in the linguistic literature about which they will probably never hear again. I hope that I have been to them what they are to me.

I am very thankful to my informants not only for the data they provided me with but also for the comments that they added to make things clearer for me: Heiko Narrog, Yasutada Sudo (Japanese), Ane Odria, Jon Ortiz de Urbina (Basque), Rajesh Bhatt (Hindi), Bradley Larson (English).

During my MA education, I have been financially supported by TÜBİTAK Scholarship for Graduate Students (2228). This has been of crucial importance to me and I gratefully acknowledge it.

I hope that writing this thesis was worth being so far from my brother, Çağdaş Bayırlı, and my three-year old sister, Ekin Bayırlı, for such a long time. I hope that, with this thesis, I have done justice to the endless and unconditional support that my father, Mehmet Bayırlı, and my mother, Zeynep Bayırlı, have given me. This thesis is dedicated to my family as an apology for all the times we could not spend together.

## CONTENT

CHAPTER I: INTRODUCTION.....	1
1.1. The Aim of the Thesis.....	1
1.2. The Outline of the Thesis.....	3
CHAPTER II: ON SUFFIXHOOD.....	6
2.1. Approaches to Suffixhood.....	6
2.1.1. Lieber (1980).....	6
2.1.2. Ouhalla (1991).....	7
2.2. The challenge from Turkish: V-X.....	9
2.2.1. Some Introductory Remarks.....	9
2.2.2. Introducing V-X.....	15
CHAPTER III: X-BAR THEORY MEETS V-X.....	19
3.1. X-bar Theory.....	19
3.2. The General Problem with X-bar Theory in Capturing V-X.....	20
3.2.1. The Problems with Suffixhood as Head-Movement.....	22
3.2.2. Antisymmetry and Suffixhood.....	32
CHAPTER IV: MIRROR THEORY and V-X.....	41
4.1. The General Picture So Far.....	41
4.2. Mirror Theory.....	42
4.3. Deriving the Word Order.....	48
4.4. Mirror as Spell-Out.....	53
4.5. A Proposal for Mirror as Spell-Out.....	54
4.6. A Mirror Theoretic Explanation to V-X.....	56
4.7. A Comparative Evaluation of Mirror and X-bar Theory.....	64
CHAPTER V: FURTHER EVIDENCE.....	66
5.1. The Verbal Item Hypothesis.....	66
5.2. Basque.....	67
5.2.1. V-X in Basque.....	67
5.2.2. On the Behavior of Verbal Items in Basque.....	70
5.3. Japanese.....	76
5.3.1. V-X in Japanese.....	76
5.3.2. On the Behavior of Verbal Items in Japanese.....	79
5.4. Hindi.....	82
5.4.1. V-X in Hindi.....	82
5.4.2. On the Behavior of Verbal Items in Hindi.....	85
5.5. English.....	86
5.5.1. V-X in English.....	86
5.5.2. On the Behavior of Verbal Items in English.....	98
CHAPTER VI: TWO NON-VERBAL ITEMS AND THEIR INFLECTION.....	101
6.1. The Non-Verbal Item Hypothesis.....	101
6.2. Turkish.....	104
6.2.1. Non-Verbal Items in Turkish.....	104
6.2.2. Noun Incorporation in Turkish.....	110
6.3. Japanese.....	112
6.3.1. Non-Verbal Items in Japanese.....	112
6.3.2. Noun Incorporation in Japanese.....	116
6.4. Hindi.....	117
6.4.1. Non-Verbal Items in Hindi.....	117
6.4.2. Noun Incorporation in Hindi.....	121

6.5. Basque.....	123
6.5.1. Non-Verbal Items in Basque.....	123
6.5.2. Noun Incorporation in Basque.....	125
6.6. English.....	127
6.6.1. Non-Verbal Items in English.....	127
6.6.2. Noun Incorporation in English.....	129
6.7. Modelling the new Lexicon.....	129
CHAPTER VII: CONCLUSION.....	138
7.1. The Summary of the Claims.....	138
7.2. Questions for Future Research.....	139

## TABLES

1. Turkish Suffixes on the Verbal Root.....	16
2. Turkish Suffixes on the Verbal G1 Suffix <i>-mA</i> .....	17
3. Turkish Agreement Suffix on the Verbal G3 Suffixes.....	17
4. Japanese Suffixes on the Verbal Root.....	68
5. Hindi Suffixes on the Verbal Root.....	82
6. English Suffixes on the Verbal Root.....	86

## ABBREVIATIONS

1/2/3	first/second/third person
ABIL	ability
ABL	ablative
ACC	accusative
AGR	agreement
AOR	aurist
CAUS	causative
COND	conditional
CONJ	conjunctive
COP	copula
COOR	coordinator
COM	comitative
DAT	dative
DEL	delimitative
DET	determiner
EPIS	epistemic
ERG	ergative
F	female
FOC	focus particle
FUT	future
GEN	genitive
GER	gerund
HAB	habitual
HON	honorific
IMP	imperative
IMPF	imperfective
INF	infinitive
INS	instrumental
LOC	locative
M	male
N	number
NEC	necessitative
NEG	negation
NOM	nominative
nV	non-verbal
OBL	oblique
P	person
PASS	passive
PAST	past tense
PERF	perfective
PLU	plural
POSS	possesive
PRE	present
PROG	progressive
Q	question particle
SUBJ	subjunctive
TOP	topic marker

## CHAPTER I: INTRODUCTION

### 1.1. The Aim of the Thesis

This thesis is mainly concerned with the nature of “suffixhood” and “verbalness”. As far as suffixhood is concerned, an assumption that both lexicalist (Lieber, 1980, i.a.) and syntactic (Baker, 1988, Ouhalla, 1991 i.a.) approaches to morphology share is that the suffixal status of a functional morpheme (i.e. whether it is a suffix or not) is to be specified as morphological information in its lexical entry. This claim implies that the suffixal status of a functional morpheme and the syntactic position that it occupies are unrelated. The first question that this thesis raises is the following:

- a. Is the suffixal status of a morpheme idiosyncratic morphological information or is it (partially or wholly) predictable from its syntactic environment?<sup>1</sup>

Based on data from Turkish, I will argue that the answer is the latter. There is actually a constraint that dictates that the morpheme syntactically right above a verbal item be suffixed to this verbal item in Turkish, and I dub this constraint ‘V-X’. If the suffixal status of a morpheme is predictable from its syntactic environment, the challenge is, then, to capture this observation as a syntax-related issue, which brings us to the second question that the thesis attempts to answer:

- b. Which theory of morpho-syntax is well-suited to capture this observation?

---

<sup>1</sup> The question definitely presupposes that inflectional morphemes occupy syntactic positions independent of the items to which they are affixed.

I argue that the X-bar Theory is not well-suited to do so. I attempt to show that Brody's Mirror Theory (Brody, 2003) is actually where the answer lies. Details aside, I try to show that the suffixal status of the functional morphemes above a verbal item is ultimately related to the inability of verbal items to behave phrasally and that Brody's system, in an antilexicalist implementation, makes it possible to capture suffixation on the verbal item as a deterministic reflex of a syntactic configuration. I, then, present evidence indicating that the languages Japanese, Hindi, Basque and English are also subject to V-X and that verbal items in these languages cannot show phrasal behavior, either. (In cases of so-called "VP" topicalization or focalization, I present evidence indicating that the item that moves is usually an infinitival element rather than a verbal element.)

Besides showing that verbal items always occupy a complement-position in the Brodian syntax, the last main question that this thesis asks is related to the status of two non-verbal items (nouns and participles).

- c. Can nouns and participles occupy the position that verbal items obligatorily occupy in Brody's syntax?

I argue that they cannot. I present evidence indicating that with a few exceptions, nouns and participles always show phrasal behavior in Turkish, Basque, Hindi, Japanese and English (unlike verbal items in these languages). In the last section, I develop a theory of lexical features that eliminates the need for [+/- suffix] and [+/- verbal] features in the lexicon and grammar, and replaces them with features that determine what position a lexical object must occupy.

The three questions above are the main questions to which this thesis will attempt to find answers. This attempt inevitably interacts with other questions and debates in the

current theoretical linguistics literature. Other questions that this thesis will have a take on are as follows:

- d. Is head-movement a syntactic (Pollock, 1989, Ouhalla, 1991, Matushansky, 2006) or a post-syntactic phenomenon (Chomsky, 2001, Harley, 2004)?
- e. What are the strengths and weaknesses of a checking theory of verbal morphology (Chomsky, 1995) and a building theory of verbal morphology (Baker, 1985, Cinque, 1999)?

## 1.2. Outline of the Thesis

In Chapter II, I discuss previous approaches to suffixhood and argue that they do not predict any relation between the suffixal status of a lexical item and its syntactic environment. I, then, introduce some facts from Turkish verbal morphology and argue that there is a constraint that dictates that the morpheme syntactically right above a verbal item be suffixed to this verbal item and I call this constraint V-X. V-X, thus, accounts for the observation that in Turkish no functional head that is immediately above a verbal item is a free morpheme.

In Chapter III, I argue that X-bar Theory is not well-suited to capture the V-X constraint. I claim that the general problem of X-bar Theory stems from the fact that both verbal projections like VPs and non-verbal projections like NPs may occupy similar positions (i.e. a complement or a specifier position) in relation to a functional morpheme and this makes it very difficult to explain suffixhood as a direct consequence of a syntactic relation between a functional object and a verbal projection. I, then, consider an analysis based on X-bar Theory where the suffixal status of a morpheme is reduced to the fact that

there is always syntactic head movement of verbal items to the next head-up and head-adjunction structure as a result of this movement obligatorily gives rise to suffixhood of the host. I argue that it may be the case that the head movement of the verbal items is related to the fact that the uninterpretable V feature of the functional heads is always strong. I indicate some conceptual problems with this approach. I, then, review one of the arguments for the syntactic nature of head-movement of the verbal negation in Turkish and argue that the evidence is not conclusive.

In Chapter IV, I present Mirror Theory as developed in Brody (2003). I, then, propose an antilexicalist implementation of this theory. I show that, in this implementation, the observation V-X is correlated with the the fact that verbal items cannot show phrasal behavior. I argue that verbal items cannot show phrasal behavior because they obligatorily occupy a complement position in a Mirror Theoretic Syntax. I end this section by giving a comparative evaluation of X-bar Theory and Mirror Theory in explaining the V-X constraint.

In Chapter V, I present evidence from Basque, Japanese, Hindi and English to show that V-X constraint is also at work in these languages. I also show that this correlates with the fact that verbal items cannot show phrasal behavior on their own.

In Chapter VI, I focus on two non-verbal items (nouns and non-verbal participles). I argue that in direct opposition to verbal items, non-verbal items can only show phrasal behavior. Based on data from Turkish, Japanese, Hindi, Basque and English, I present evidence indicating that inflection on nouns and participles is not suffixation as a result of head-to-head adjunction. I argue that nominal inflectional elements attach to phrasal items. I also argue that a head-movement analysis of noun incorporation phenomenon is faced with empirical problems in these languages. I bring this section to an end by outlining a

theory of lexical features in which the [+/- verbal] and [+/- suffix] features are replaced by features that show the syntactic position which a lexical item must occupy.

In Chapter VII, I summarize the claims of the thesis and present some remaining issues that need to be addressed in future works.

## CHAPTER II: ON SUFFIXHOOD

In this chapter, I first attempt to review the claims of lexicalist (Lieber, 1980 i.a.) and syntactic (Baker, 1988, Ouhalla, 1991 i.a.) approaches to inflection as far as the object<sup>2</sup> called “suffix” is concerned.<sup>3</sup> I then attempt to show that both approaches miss some generalizations and that some data from verbal morphology of Turkish call for an explanation that makes reference to the syntactic environment of suffixal objects.

### 2.1. Approaches to Suffixhood

#### 2.1.1. Lieber (1980)

Lieber (1980) presents a detailed illustration of a lexicalist approach to word formation. I will focus mainly on the mechanism that Lieber uses to differentiate between stems and affixes.

Lieber (1980) argues that affixes differ from stems in that affixes “have as part of their lexical entries frames indicating the category of items to which they attach as well as the category of items produced” (p. 63). The English suffix *-ize* (as in *modern-ize*), for example, differs from a non-affix by having a subcategorization frame which looks like:

---

<sup>2</sup> In most of the discussion in this thesis, I use the term ‘object’ not as a way of referring to the grammatical function (e.g. direct, indirect object) but as a general term that covers items from the lexicon (lexical, functional, free or bound), i.e. as *objects* that syntax and/or morphology manipulate.

<sup>3</sup> The questions that this thesis is concerned with are close to the questions asked by other syntactic approaches to morphology like Distributed Morphology (Halle and Marantz, 1993 i.a.) where word-formation processes, including inflection, are handled syntactically or post-syntactically. I do not adopt Distributed Morphology (DM) in this thesis as I do not make use of the technology (late insertion of vocabulary items, underspecification etc.) that it employs. This is, of course, not to say that the thesis is incompatible with DM.

1. -ize

]N\_ ]V

This indicates that it attaches to nouns and makes a verbal category out of them.<sup>4</sup> Note that in this conception, objects such as “affix” or “stem” are not taken to be primitives of lexical information. Rather, their definitions follow from whether or not they have a subcategorization frame. Having a subcategorization frame or not, on the other hand, is taken to be idiosyncratic as this quote should make clear: “embodied in the idiosyncratic information expressed in lexical entries is the distinction between free morphemes, or stems, and bound morphemes or affixes” (Lieber, 1980 p. 66). Stems and affixes come together in the lexicon via unlabelled binary branching trees, and feature percolation conventions regulate the labeling of such complex objects. Such objects are, then, input to syntactic computation.

2.1.2. Ouhalla (1991)

Ouhalla (1991), following Baker (1988 i. a.), argues for a syntactic approach to how affixes and roots come together. As far as differentiating affixes from non-affixes is concerned, Ouhalla also resorts to morphological specification in a way that is slightly different from Lieber (1980). What is a “subcategorization frame” in Lieber’s work is now a “morphological selection (m-selectional)” requirement. As Ouhalla (1991) puts it: “Let us assume ... that bound categories have morphological selectional (m-selectional) properties which specify, among other things, the categorial nature of the item that they

---

<sup>4</sup> Lieber argues all word-formation processes including inflectional and derivational affixation take place in the lexicon. An inflectional affix would have a similar representation to the derivational affix *-ize* in having a subcategorization frame.

can attach/ adjoin to” (p.15). However, unlike Lieber (1980), Ouhalla does not take m-selectional requirements as differentiating between bound and free categories. He argues that having an m-selectional requirement (among others) basically differentiates functional categories from substantive categories. The bound or free status of a functional morpheme should be stated as a distinction in m-selectional requirements. More precisely, bound morphemes have the m-selectional requirement of being bound while free morphemes have the m-selectional requirement of being free.

Ouhalla departs from Lieber’s claim that inflectional affixation takes place in the lexicon. Instead, following Baker (1988 i.a.), he argues that bound functional morphemes head their own distinct projections in syntax and that they function as *triggers* for head-movement operations. The reason for this movement is one of the requirements of the Generalized Projection Principle (GPP), which states that

2. “The m-selectional properties must be satisfied at the S-structure level.” (Ouhalla, 1991 p.25)

Ouhalla argues that head-movement is actually triggered by this requirement of GPP. That is, head-movement of a lexical object to a bound category is a way of satisfying m-selectional requirement of the bound host.

As we have noted, Lieber (1980) and Ouhalla (1991) differ in the mechanism they propose for how stems and affixes come together. On the other hand, an assumption that both share is that the suffixal status of a functional morpheme and the syntactic environment in which it occurs are completely unrelated. For Ouhalla, for example, any functional morpheme that has the requirement of being bound (by m-selectional requirement) can be a suffix no matter what syntactic environment it occupies. In the next

section, I argue that the suffixal status of a morpheme and its syntactic environment are related. This brings us closer to an understanding of suffixhood as a syntax-related phenomenon.

## 2.2. The Challenge from Turkish: V-X

### 2.2.1. Some Introductory Remarks

The nature of functional morphemes in the Turkish verbal domain has received a lot of attention (Yavaş, 1980; Kornfilt, 1996; Aygen-Tosun, 1998; Öztürk, 1999; Kelepir, 2001; Sezer, 2001; Göksel, 2001; Enç, 2004; i. a.). In this section, I will basically present a categorization of Turkish suffixes on the verbal domain based on these works.

The first group of suffixes that I would like to mention consists of the negation marker *-mA* and the abilitative modality marker *-yAbil*. These suffixes attach to verbal items. Categorically, they are themselves verbal in the sense that they can be followed by infinitival marker as in (3a) and (3b), which only attaches to verbs (4a) and not to adjectives or nouns (4b, c). I will refer to them as ‘Group 1 suffixes’.

3. a. gel -me -mek

come-Verb.NEG-INF

“to not come”

b. gel -ebil -mek

come-ABIL-INF

“to be able to come”

4. a. gel -mek

come-INF

“to come”

b. \*yorgun-mak

tired-INF

Int. “to be tired”

c. \*masa-mak

table-INF

Int. “to make table”



A group 1 (G1) suffix takes a verbal item as input and gives a verbal item as output. I will refer to this group of suffixes as verbal G1 suffixes. I use the term ‘verbal’ to express the fact they are themselves verbal (and not to express the fact that they attach to verbal elements). Their behavior can be expressed as below:

5.  $+v \rightarrow +v$   
| -G1- |

One way in which a G1 suffix is different from any other suffix that will be introduced below is that they can never carry an agreement marker. Agreement may only attach on a suffix that follows them.

Turkish is known to have two main paradigms of subject agreement. Paradigm 1 has traditionally been called the “z-paradigm” of subject agreement and Paradigm 2 has been called the “k-paradigm” of subject agreement. The names for the two paradigms

come from the 1<sup>st</sup> person plural markers which make the distinction between these paradigms clear (for discussion, see Yu and Good, 2000 i.a.).

6.	Paradigm 1	Paradigm 2
	Come-NEC-AGR	come-PAST-AGR
1SG	gel -meli -yim	gel -di -m
	“I must come”	“I came”
2SG	gel -meli -sin	gel -di -n
	“you must come”	“you came”
3SG	gel -meli -Ø	gel -di -Ø
	“s/he must come”	“s/he came”
1PL	gel-meli -yiz 	gel-di -k 
	“we must come”	“we came”
2PL	gel-meli -siniz	gel-di -niz
	“you (pl) must come”	“you (pl) came”
3PL	gel-meli -ler	gel-di -ler
	“they must come”	“they came”

The second group of functional morphemes that I want to differentiate is participles. This group consists of perfective/evidential *-miş*, progressive *İyor*, necessitative *-malı*, future *-yAcAk* and aorist *-Ir*. Following Kelepir (2001), Sezer (2001) and Enç (2004), I take this group to be non-verbal in nature because they get their agreement markers from the “z paradigm” together with nominal, adjectival and postpositional predicates.

7. a. Gel -miş -iz  
come-PERF/EVID-1PL

“we have come”

b. Gel -iyor -uz  
come-PROG-1PL

“we are coming”

c. Gel -meli -yiz  
come-NEC-1PL

“we must come”

d. Gel -ir -iz  
come-AOR-1PL

“we (usually) come”

e. İnsan -ız  
human-1PL

“we are human”

f. Yorgun -uz  
tired-1PL

“we are tired”

g. Ankara'da -yız  
Ankara-LOC-1PL  
“we are in Ankara”

A group 2 (G2) suffix takes a verbal element as its input and gives a non-verbal element as its output. To emphasize their non-verbal nature, I will use the term “non-verbal suffix” when I make reference to them. Their syntactic behavior can be expressed as the following:

8.  $+v \rightarrow -v$   
    | -G2 |

The last group is what Kornfilt (1996) calls the ‘genuine finite forms’: the past tense *-DI* and the conditional *-sA*. These two suffixes get their agreement from the k-paradigm, which is different from the paradigm of participles (G2 suffixes).

9. a. Gel -di -k  
    come-PAST-1PL  
    “we came”  
    b. Gel -se -k  
    come-COND-1PL  
    “if we came...”

The category of these suffixes is unclear. Since they get their agreement markers from a paradigm which is different from the non-verbal items (i.e. since they get their agreement

markers from the k-paradigm rather than the z-paradigm) and since they show some grammatical behavior similar to verbal items (as will be explicated in the thesis), I will take this last group to be verbal in nature,<sup>5</sup> following Özsoy (2001: 232 fn. 3). They will be called ‘Group 3 Suffixes’ throughout the thesis.

A group 3 (G3) suffix takes a verbal element as its input and still produces a verbal element as its output. Their syntactic behavior can be expressed in this way:

$$10. \begin{array}{ccc} +V & \rightarrow & +V \\ & \text{[-G3-]} & \end{array}$$

One relevant question is what it is that shows – other than the convention that they are written as bound - that these objects are really suffixes (and not, say, clitics or even free forms). The theory that I develop here argues that being a suffix means occupying a designated syntactic position among those made available by Mirror Theoretic syntax of Brody (2003). Then, at least some of the tests that show whether a certain object is a suffix are no different from the tests that show whether such an object occupies the alleged position. Therefore, I postpone this question until the later parts of the thesis where I explicate a theory of what makes a lexical object a suffix. We will then understand why (at least some of) the tests that show whether an object is a suffix work the way they do.

---

<sup>5</sup> An alternative analysis which takes G3 suffixes as non-nominal and non-participle is possible. That is, one does not have to assume that they are [+verbal] as I do here. It may be argued that they are actually categoriless in some sense. I take them to be verbal because of the similarity of their behavior with bare verbs.

### 2.2.2. Introducing V-X

We have seen that lexicon-based approaches do not predict any relation between the suffixal status of a morpheme and its syntactic environment. In this section, I would like to argue that the suffixal status of a morpheme is predictable from its syntactic environment in Turkish.

Looking at the data introduced in this section, it seems as though all the functional morphemes in Turkish are suffixes. This, however, is not true. It should be noted that, besides the negation marker introduced in (3a), there is another negation morpheme that takes non-verbal items as its complement and that is a free morpheme. I will dub it non-verbal negation (nV.NEG).<sup>6</sup>

11. a. Gel-miş      değil      -iz  
      come-PERF    nV.NEG-1PL  
      “it is not the case that we have come”
- . b. Yorgun      değil      -iz  
      tired        nV.NEG-1PL  
      “we are not tired”
- c. Öğrenci değil      -iz  
      student nV.NEG-1PL  
      “we are not students”

---

<sup>6</sup> Let us assume, for the time being, that the fact that a morpheme is written separately is enough reason to believe that it is not a suffix. In the later phases of the thesis, I will provide more reliable tests for suffixhood.

Nouns, adjectives or G2 suffixes in Turkish may be followed by a copula. Note also that in participle - verbal copula complexes, the verbal complex including the copula is always non-suffixal (even when it is cliticized)

12. a. Gel -miş      i -di -k  
       come-PERF      cop-PAST-1PL  
       “we had come”
- b. Gel-ecek      i -se -k  
       come-FUT      cop-CON-1PL  
       “if we will come...”

However, the functional morpheme immediately above a verbal item is never a free morpheme. It has to be suffixed to this verbal item. Therefore, the forms in the rightmost column in Table 1 are all ill-formed.

Table.1 Turkish suffixes on the Verbal Root

Glosses	Existent Structures Suffixation	Non-existent Structures Free Morphemes
come-PAST	gel-di <sub>G3</sub>	*gel di
come-COND	gel-se <sub>G3</sub>	*gel se
come-PROG	gel-iyor <sub>G2</sub>	*gel iyor
come-FUT	gel-ecek <sub>G2</sub>	*gel ecek
come-PERF	gel-miş <sub>G2</sub>	*gel miş
come-AOR	gel-ir <sub>G2</sub>	*gel ir
come-NEG-PAST	gel-me <sub>G1</sub> -di	*gel me-di

It is not only the morpheme that is syntactically right above the verb that is a suffix. The morpheme that is syntactically right above a verbal G1 suffix is also a suffix.

Table.2 Turkish Suffixes on the Verbal G1 Suffix *-mA*

Glosses	Existent Structures Suffixation	Non-existent Structures Free Morphemes
Verb-Verb.NEG-PAST	gel-me <sub>G1</sub> -di <sub>G3</sub>	*gel-me di
Verb-Verb.NEG-COND	gel-me <sub>G1</sub> -se <sub>G3</sub>	*gel-me se
Verb-Verb.NEG-PROG	gel-mi <sub>G1</sub> -yor <sub>G2</sub>	*gel-mi yor
Verb-Verb.NEG-FUT	gel-me <sub>G1</sub> -yecek <sub>G2</sub>	*gel-me yecek
Verb-Verb.NEG-PERF	gel-me <sub>G1</sub> -miş <sub>G2</sub>	*gel-me miş
Verb-Verb.NEG-AOR.AGR	gel-me <sub>G1</sub> -z <sub>G2</sub>	*gel-me z

Lastly, the same restriction applies to the morpheme immediately above the G3 suffix.

Table.3 Turkish Agreement Suffix on the Verbal G3 Suffixes<sup>7</sup>

Glosses	Existent Structures Suffixation	Non-existent Structures Free Morphemes
Verb-PAST(V)-1SG	gel-di <sub>G3</sub> -m	*gel-di m
Verb-COND(V)-1SG	gel-se <sub>G3</sub> -m	*gel-se m

The (un)grammaticality of all these cases points to the following observation, which I formulate as a constraint on Turkish verbal morphology:

13. V-X (X, a suffix)

<sup>7</sup> Agreement is the only possible morpheme above the past tense and conditional suffix.

Informally, this constraint says that *the morpheme immediately above a verbal root or a verbal suffix has to be suffixed to this verbal item*. It is impossible that the morpheme immediately above the verbal item is a free morpheme or a clitic or a prefix.

Note that this constraint could be formulated in a weaker way as “\*V X (X, a free morpheme)”, which would mean that the functional morpheme immediately above the verbal item can be anything but a free morpheme following the verbal item. This would allow the functional morpheme syntactically above the verbal item to be a prefix, a phrasal affix or a free form preceding this verbal item. However, the stronger position that says that the functional morpheme above the verbal item can be nothing but a suffix seems to work. Therefore, I take this stronger position throughout the thesis.

In this section, I tried to show that there is a relation between the suffixal status of a morpheme and its syntactic environment. An approach that argues that the suffixal status of a morpheme is idiosyncratic morphological information specified in the lexicon can interpret this only as an accident. I will assume that this is not an accident and that this must be explained in a way that makes reference to syntax. The next step, then, is to capture this fact as a syntax-related issue. In the next chapter, I will attempt to show that X-bar Theory is not well-suited to do so.

## CHAPTER 3: X-BAR THEORY MEETS V-X

In the previous section, I attempted to show that as far as Turkish suffixes in the verbal domain are concerned, the suffixal status of a morpheme and its syntactic environment are related. The challenge is, then, to capture it in syntax or as a reflex of syntax. In this section, I will try to give some evidence that the phrase structure as envisioned in X-bar Theory (Chomsky, 1970) is not well-suited to do so.

### 3.1. X-bar Theory

X-bar Theory was first introduced in Chomsky (1970) and further elaborated on in Jackendoff (1977 i.a.). It was extended to cover functional categories in subsequent work (Ouhalla, 1991, Pollock, 1989 i. a.). The crucial assumption in these subsequent works is that lexical and functional categories have the same X-bar schema available to them. That is, lexical heads like nouns, verbs, adjectives and functional heads like tense, aspect, mood etc. may take a complement and have a specifier. Leaving aside for the time being the case of adjunction and the issue of head-directionality, the phrase structure available to all lexical and functional categories is given below:

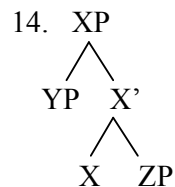

Here, X is understood as a variable that ranges over N, V, A, Adv, T, Asp, D, P etc... ZP is the complement, while YP is the specifier of the head X. For instance, an Asp head must project to an Asp' and then to a full phrase, an AspP, and have a complement and a specifier.

### 3.2. The General Problem with X-bar Theory in Capturing V-X

Let us go back to our question about understanding suffixhood as a 'syntax-related' phenomenon. Note that we have observed an asymmetry between verbal items and non-verbal items in terms of triggering suffixation. We have seen that while verbal items require that the morpheme above them be a suffix (Table 1, 2, 3), no such requirement holds for non-verbal items (nominals, participles as in the examples 11,12). One possibility is that this difference can be reduced to differences in the syntactic representation of verbal and non-verbal items in relation to the functional head that is expected to show suffixal behavior. The problem with X-bar Theory seems to be that both verbal and non-verbal elements can occupy the same positions (i.e. the complement or the specifier positions) in relation to a functional head and this makes it difficult to understand how suffixhood can be derived from structural representation. Let us represent the case in which a verb phrase and a noun phrase (as an example of a non-verbal phrase) are taken as complement by a functional head or the case in which a verb and a noun phrase are in the specifier position of it (let's call it F). I leave aside the specifiers and continue representing trees without assuming a certain head-complement order.

15. a. The structure of VP as a complement

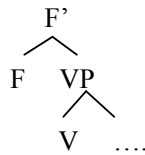

15.b. The structure of NP as a complement

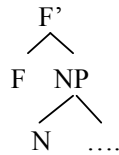

16.a. The structure of VP as a specifier

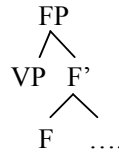

16.b. The structure of NP as a specifier

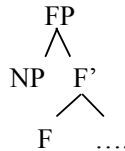

All the structures above are admissible phrase structures in X-bar Theory. That is why, X-bar Theory makes it impossible to predict the (non)suffixal status of the functional head F based on its environment. The reason for this is that X-bar syntax allows both V and non-V projections to appear in the same syntactic environment (that is, to appear both as complements and as specifiers). Unless we make additional assumptions (to which I will

come soon), there does not seem to be any principled reason why the F head in 15.a. and 16.a has to be realized as a suffix while F head in 15.b. and 16.b. need not be.<sup>8</sup>

### 3.2.1. The Problems with Suffixhood as Head-Movement

We have seen above that X-bar Theory needs some auxiliary assumptions to capture the suffixhood of the morpheme immediately above a verbal item. In what follows, I will try to see what these auxiliary assumptions are and whether they are justified.

With the assumption that Turkish is a head-final language and that the X-bar schema basically is the phrase structure of human language, the received approach to Turkish verbal morphology is that verbal roots and functional suffixes come together by syntactic head movement (Kural, 1993, Öztürk, 2005, Ulutaş, 2006 i.a.). In this section, I will develop a syntactic account of suffixhood based on its relation with syntactic head movement. I will refer to this approach to suffixhood as ‘X-bar plus Head-Movement’.

Our question is this: Can suffixhood of the morphemes above a verbal item be captured without the assumption that functional items are specified for [+/- suffix] feature in the lexicon? One of the ways could be the following: In Turkish, verbal items (for some reason unlike non-verbal ones) always move to the next head up. This movement results in head-to-head adjunction as given below:

---

<sup>8</sup> Modal constructions in English as ‘will come’ and constructions with infinitive marker such as ‘to come’ form counter-evidence to the claim that the functional morpheme immediately above a verbal item has to be a suffix. In section 5.5.1, I will try to bring cross-linguistic and language-internal evidence that English verbs that seem to be bare are actually headed by a null infinitival marker following Hornstein, Martins and Nunes (2008).

17. WP

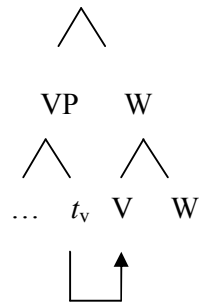

Let us further assume that head-to-head adjunction (as in the tree above) is a structure which is obligatorily interpreted as suffixation (Julien, 2002 i. a.). Then, the fact that all the morphemes immediately above a verbal item are suffixes can be reduced to the fact that all verbal items obligatorily head-move to the next head up.

We must, then, ask what the trigger of this movement is. I assume that uninterpretable features are crucially involved in categorial selection (c-selection) of the complements (Svenonius, 1994, Holmberg, 2000, Julien, 2002). That is, a T head c-selects for a VP if this T head has an uninterpretable V feature and a D head c-selects for an NP if this D head has an uninterpretable N feature and so on. What we want to do now is to find a way of expressing the observation that an uninterpretable V feature always triggers head-movement and that an uninterpretable N feature need not do so. Holmberg (2000: 137), following and extending Svenonius (1994), argues that an uninterpretable feature can be checked in one of three ways given below:

18. a. pure feature movement (i.e. covert movement)
- b. head-movement
- c. phrasal movement

Let us leave the last option (c) aside for now and focus on the options (a) and (b). Let us assume that if an uninterpretable feature is strong, it must be checked by overt head-movement (b) and if it is not strong, it is checked by feature movement only (a).

We have seen that the movement of the verb to the next head up is obligatory. We have also seen that there are cases where the non-verbal item does not move as in the case of non-verbal negation (repeated from 11c)

19. Öğrenci değil -iz  
student nV.NEG-1PL  
“we are not students”

One question that remained unanswered was this: Does a non-verbal item ever move to the next head up? We might think that this is the case below:

20. kitap-lar  
book-PLU  
“books”

The question of whether such constructions are to be analyzed as head-to-head relation will be addressed in Chapter VI. Nevertheless, we must somehow capture the fact that the movement of a verbal item is obligatory while the movement of a non-verbal item is not. One way to do so would be to say that an uninterpretable V feature of the functional morpheme above the verb is always strong and that it always triggers head-movement. Uninterpretable N feature, on the other hand, need not be strong.

There are some problems with this solution. Firstly, it is completely unclear what prevents the presence of uninterpretable V feature that is not strong. Secondly, any account that does not resort to strength of features to explain the same range of data should be preferred.

Noting these problems, we realize that another issue arises. An explanation based on strong/weak uninterpretable features of functional heads assumes that head-movement is a syntactic phenomenon. However, that head-movement is a syntactic operation is a controversial issue. Chomsky (2001), for example, argues that certain properties of head-movement seem to indicate that it is not part of the narrow syntax. For one thing, there is a difference between head-movement and phrasal movement in terms of semantic consequences. As Chomsky (2001) notes “more generally, semantic effects of head-raising in the core inflectional system are slight or nonexistent, as contrasted with XP-movement, with effects that are substantial and systematic” (p. 37). There, also, seem to be several other differences between X-movement and XP-movement. Chomsky (2001) lists the properties of head-movement as follows: “it [head-movement, IKB] is an adjunction rule; it is countercyclic in ways that are not overcome along the lines discussed earlier; the raised head does not c-command its trace [...] it observes somewhat different locality conditions” (p. 38). These aspects of head-movement differ from what is observed about phrasal movements. Several other arguments to the conclusion that head-movement is not a syntactic phenomenon can be found in Harley (2004).

On the other hand, Matushansky (2006) attempts to show that head-movement is actually more similar to phrasal movement than previously thought. Matushansky first notes that head-movement is always local while phrasal movement is never so. With the assumption that the features play a crucial role in categorial-selection (Svenonius, 1994 i.a.), she argues that head movement becomes a possibility only when an uninterpretable

feature is checked under categorial-selection. This explains why head-movement is as local as c-selection. The phrasal movement, then, is movement when uninterpretable feature cannot be checked under c-selection since “a head ceases to be accessible once another head starts to project (Transparency Condition)” (Matushansky, 2006 p. 78). In the phrasal movement scenario, features can be checked only by a long distance AGREE operation. Thus, the only difference between head movement and phrasal movement is how the features of the items that may trigger such movements are checked (i.e. c-selection or AGREE). To solve the c-command problem (i. e. the problem that a more complex definition of c-command is needed to express the fact that a head that is moved c-commands its trace) and the root extension problem (i.e. the problem that head movement does not extend the tree in the way that phrasal movement does), Matushansky argues that heads also move to specifier positions (as a result of which they extend the tree and they can c-command their trace) but they undergo a morphological operation with the heads to whose specifier they have moved and this operation is called m-merger. Matushansky also argues that treating head-movement as a PF-phenomenon is incompatible with the Phase Impenetrability Condition of Chomsky (2000). Other arguments against the view that head-movement is a PF-operation can be found in Zwart (2001).

I will not attempt to evaluate the validity of the arguments made above. However, this debate is important for this thesis because an explanation based on the strong/weak uninterpretable features on the functional heads basically assumes that head-movement is a syntactic phenomenon. Given that this issue is contested, some independent evidence for the syntactic nature of head-movement in Turkish must be provided. In this section, I will present one such argument put forth by Ulutaş (2006) and Kural (1993) and argue that there are cases where this argument does not hold.

It has been argued in Kural (1993) that Turkish NPIs (here the object) must be c-commanded by negation at S-structure. Ulutaş bases his argument for the syntactic Neg-movement on this observation. In (21), there is an NPI object that precedes the adverb *sabırla* ‘patiently’. By showing that the object has moved over the adverb, he argues that it is in a position lower than TP but higher than vP. Since the NPI object should be licensed by a c-commanding negation, it must be assumed that the negation head of the verbal morphology has moved to the T-head position from where it can c-command the object and license it. Since this is a licensing relation, it must be syntactic:<sup>9</sup>

21. [Ali<sub>k</sub> kimse-yi<sub>i</sub>     [t<sub>k</sub> [sabırla     t<sub>i</sub> t<sub>j</sub>]]     dinle<sub>j</sub>-me-di].

Ali    anyone-ACC     patiently                    listen-NEG-PAST

“Ali didn’t listen to anyone patiently.” (Ulutaş, 2006 p.44)

Therefore, it must be the case that Neg has moved to T head syntactically. We should note that there is a problem with this argument. As noted in Ulutaş (2006: 45 fn. 25) it is still possible that the object moves to a position lower than NegP. It is possible that the NPI object adjoins to vP or moves to a AgrOP below NegP. In such cases, the object could be licensed from the base-generated position of the negation head. No movement of NEG to T would be needed.

An argument similar to Ulutaş’s is made in Kural (1993). Kural takes the NPI subject to be in its regular [Spec TP] position. Kural argues that in order to license the subject, the negation head (along with the verb) must have moved to a C position from where it can c-command the subject. In the example (22), the NPI in the subject position is

---

<sup>9</sup>I changed the glosses for ease of exposition

clearly in a higher position than the base position of negative head, indicating that Neg head has undergone head-movement in syntax.

22. Kimse -Ø                      koş -ma -dı -Ø  
    anyone-NOM                  run-NEG-PAST-AGR  
    “Nobody ran”

What I would like to do now is to show evidence indicating that there are cases where this argument for syntactic head movement of Negation does not work. In the example below, let us assume that the NPI subject is in its regular [Spec TP] position. Let us focus on the licensing of this NPI subject in this sentence (leaving aside for the time being the position of the object in the tree representation). In the tree (24), we see a case where the head of the verb phrase moves to the head of Neg Phrase and then this complex of (V-Neg) head-moves to the Asp Head (I ~~strike out~~ the phonologically null copies). In this situation, the Neg head is below the verbal copula (VP). For it to license the NPI subject at Spec T, we have to assume that the aspect complex containing the negation head (i.e. the “V-Neg-Asp Complex”) adjoins to the verbal copula *i-* and then to the T head (and then probably to AgrS or to C).

23. Hiçbirimiz o-nu              tanı -mı -yor              i -di -k  
    none-of-us he-ACC          know-NEG-PROG          cop-PAST-1PL  
    “None of us knew him”

24.

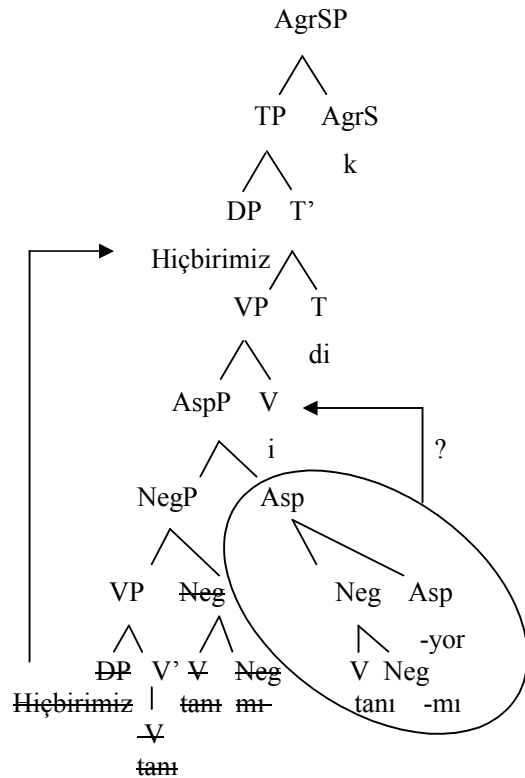

Let us now focus on the movement of the complex head “tanı-mı-yor” to the copula head V.<sup>10</sup> It seems that there are several reasons to doubt this operation. This movement is a case of head-to-head adjunction. However, it should be noted that this movement does not result in suffixation. The verbal copula to which the V-Neg-Asp complex is supposed to move is not a suffix. If such a head adjunction structure that does not end up in suffixation is possible, then, the whole argument to capture suffixhood as a reflex of a head-to-head adjunction would face a serious problem. That is, if there are cases where head-to-head adjunction does not give rise to the suffixal status of the morpheme that hosts this complex,

<sup>10</sup> The claim that verbal copula projects its own phrase is controversial (see Keleşir, 2001, Göksel, 2001 and Enç, 2004 for alternative analyses). There are certain asymmetries between the copular verb *i-*, the copula verb *ol-* and other lexical verbs. For instance, the infinitival marker cannot appear on the copular verb *i-*. Also, the copular verb seems to be semantically vacuous. I acknowledge such facts but continue to assume that it heads its own projection. See Keleşir (2012) for a discussion of different types of copular verbs in Turkish languages.

then the research program that attempts to derive suffixhood from this syntactic configuration fails, it seems.

There is another problem. There seem to be empirical reasons to believe that the V-Neg-Asp complex does not head-move to the copular head. Let us look at the sentence in (25) whose syntactic representation is given in (26). (25) is a coordinate structure. The conjuncts contain two participial predicates and their objects. Let us focus our attention on how the NPI subject is to be licensed in (26) below. If NPI subjects are licensed by the c-commanding negation head, we again need to assume that one of the V-Neg-Asp complexes moves to the verbal copula and then to T head (and then probably to AgrS head). (The negation is underlined inside each V-Neg-Asp complex in tree representation and the AspP contains NegP and vP)

25. [Hiçbirimiz<sub>i</sub> [ *t<sub>i</sub>* o-nu tanı -mı -yor ve *t<sub>i</sub>* o-na yardım et -mi -yor ]  
i -di -k]

Anyone-of-us she-ACC know-NEG-PROG and she-DAT help give-NEG-PROG  
cop-PAST-1PL

“None of us knew her and helped her”

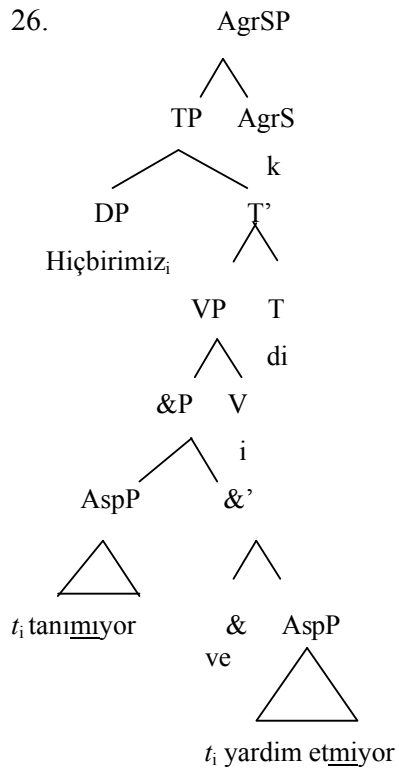

In order to license the NPI subject in [Spec TP], one of V-Neg-Asp complexes must move to the V head that takes the &P as its complement. The problem with this movement is that this is a coordination structure and there is a well-known ban on movement out of coordinated structures (Coordinate Structure Constraint of Ross, 1967). Even though across-the-board movement from coordination is a possibility when the item moved is identical on both sides of the coordination, this is no such case. Therefore, we need to assume that the alleged movement of the negation head to T head in syntax is not what actually happens here.

I do not have a proposal as to how the subject NPI is licensed. All I claim is that NPI licensing is to a degree independent of Neg movement. Therefore, it cannot be used as an argument for syntactic head movement of Neg.<sup>11,12 13</sup>

In this section, I tried to argue that X-bar Theory plus Head Movement approach to suffixhood has several problems. One is that an explanation based on strength of features invites the question of why an [uV] feature is always strong. A second problem is that at least one of the pieces of the evidence showing that such a syntactic head movement does take place is confronted with empirical problems. If there is no syntactic head movement, then suffixhood cannot be understood as being a consequence of such an operation.

### 3.2.2. Antisymmetry and Suffixhood

In this section, I will briefly introduce the Theory of Antisymmetry (Kayne, 1994) and its consequences for head-final languages like Turkish. We will see that, in the most direct implementation, Antisymmetry does not predict suffixhood in the Turkish morphology as a result of head-to-head movement. Rather, it predicts that affixation in Turkish is realized as affixation on the phrase (i.e. phrasal affixation). We will see that the expectations of the theory are not fulfilled in the verbal domain. And this will give us another observation that should be captured in a non-lexicalist theory of suffixhood.

---

<sup>11</sup> There are other arguments in the literature to the effect that head-movement is syntactic including Miyagawa's (2001 i.a.) work relating V raising to EPP-driven scrambling among many others. I will not review them here and leave them as topics to be addressed in future work.

<sup>12</sup> Arguments against syntactic head-movement can also be found in Göksel (1993). Göksel does not share, however, the assumption that the order of suffixal morphemes on the verbal item reflects their syntactic hierarchy (i.e. Mirror Principle of Baker (1985)).

<sup>13</sup> See Öztürk (2005) for the arguments that Turkish subjects do not have to move to SpecT. See Kelepir (2001) for the argument that the position of the negative operator is not limited to the position of the negation morpheme.

The Theory of Antisymmetry (Kayne, 1994) mainly argues that the relation between hierarchical structure and linear order is more direct than assumed previously. In the head-directionality approach, a language in which adpositions precede their complement (say English) and a language in which adpositions follow their complement (say, Turkish) could have the same hierarchical structure. However, Kayne (1994) argues that “antisymmetric c-command invariably maps into linear precedence” from which it follows that “if two phrases differ in linear order, they must also differ in hierarchical structure” (p. 3). Kayne attempts to show that some aspects of X-bar Theory (a head’s inability to take another head as a complement, a phrase’s inability to have two heads, a phrase’s inability to have two phrases and nothing else...) are consequences of the fact that a legitimate phrase structure is also the one that is linearizable (i.e. a-symmetric). As far as Specifier-Head-Complement (S-H-C) order is concerned, Kayne first shows that linearizability dictates that specifiers and complements be on opposite sides of the head, which reduces the six possible permutations (S-H-C, H-S-C, S-C-H, H-C-S, C-H-S, C-S-H) to two (S-H-C and C-H-S) and then makes an argument from typology to the conclusion that there is only one order available: S-H-C. This, then, has dramatic effects on the earlier analysis of head-final languages in which heads were argued to follow their complement. SOV order in head-final languages, for example, could no longer be thought as the base-generated underlying order. It must be assumed that objects move to some specifier position so that they precede V.

One of the proposals that Kayne (1994: 52) makes for how head-final order is derived is this:



seem to be happening is the phrasal movements of NP to the specifier of Num head and the remnant movement of NumP to the specifier of Poss head as in (29):

29.

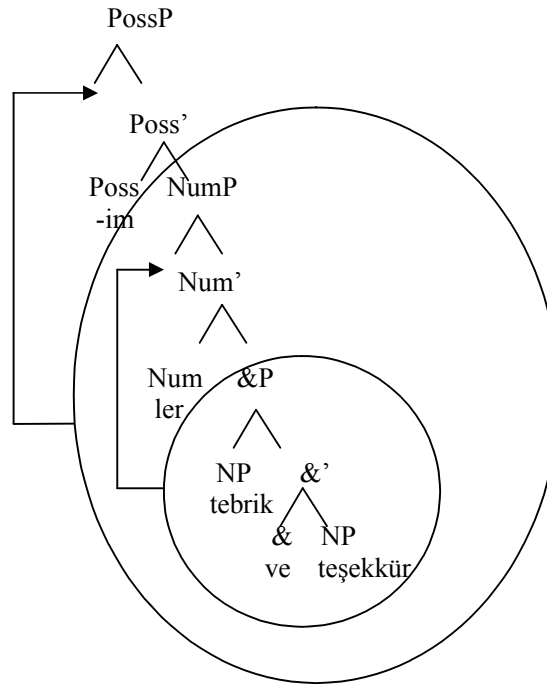

Zwart (2002), however, notes that this cannot be generalized to all inflection in Turkish.

For instance, G3 suffixes (past tense *-DI* and conditional *-SA*) do not allow for suspended affixation (The examples are from Kornfilt, 1996: 110)

30. \*Kitab-ı      [oku -du      ve      anla      -dı]      -n  
           book-ACC    read-PAST      and    understand-PAST      2SG

Int. “you read and understood the book”

Zwart hypothesizes that it may be the case that the way the past tense morpheme *-DI* and agreement are related to the verb is not via overt syntactic movement but by being base-generated on the verb. This hypothesis is only tenable in the checking theory.

Chomsky (1995) describes Checking Theory as follows: “The other approach is to take  $\alpha$  to have inflectional features in the lexicon as an intrinsic property (in the spirit of lexicalist phonology); these features are then checked against the inflectional element I in the complex [I  $\alpha$ ]” (p. 195). The claim that verbs come inflected from the lexicon is not compatible with the goals of this thesis. To the extent that the suffixal status of a morpheme and its syntactic environment are relevant, the lexicon should not be allowed to have information about suffixhood. Assuming that V-X is true, checking-like approaches do not tell us why this is so. They can only state it as an irreducible fact. Therefore, I assume that checking is not the answer here.

It may be argued that the problem in examples as (30) is with coordination of the verbal items. It is true that for some reason they can never be coordinated.<sup>14</sup> We should note that this constraint on coordination of “verb-G3 suffix” complex is replicated with the coordination of verbal G1 suffixes as in (31) (to my knowledge, this first was noted in Kabak, 2007):

31. \*[Oku -ma ve anla -ma] -di -n  
 read-NEG and understand-NEG-PAST-2SG  
 Int. “you did not read and understand”

As Kornfilt (1996: 111) notes, bare verbs can never be coordinated, either.<sup>15</sup>

<sup>14</sup> See section 5.5.2. on the question of whether verbal item coordination is possible in English or not.

<sup>15</sup> Yılmaz Kılıçaslan (p.c.) asks me to consider the possibility that the Turkish suffix *-yIp* in Turkish is a coordinator as in:

- i. Yaz-ıP sil -di -m  
 write-IP delete-PAST-1SG  
 “I wrote things and deleted them”

32. \*[Oku ve anla] -dı -m  
 read and understand-PAST-2SG  
 Int. “I read and understood it”

In Kayne (1994), it is argued that it is only phrases that can be coordinated and that heads never allow coordination. This is because, Kayne argues, coordinated heads are too symmetric to linearize. It seems that in Turkish the way verbs and verbal suffixes behave in such structures is more like heads than phrases.

Another interesting observation is that verbs and verbal suffixes cannot move to the specifier of the interrogation head. (The ungrammaticality of example 33c is discussed in Kornfilt, 1996 and probably in earlier works)

---

Some evidence that this is a case of coordination comes from the fact that past tense is shared between two ‘conjuncts’. Also, there seems to be some cases where negation is shared:

- ii.       Gid-ip gör -me -di -k  
 Go-IP see-NEG-PAST-1PL  
 “we did not go and see”

These are the pieces of evidence implying that this is a case of verbal item coordination. However, there are also cases where negation morpheme cannot be shared between two clauses:

- iii.       Gel-ip gel -me -diğ -ini bil -mi -yor -um  
 Come-IP come-NEG-NOM-2SG know-NEG-PROG-1SG  
 “I do not know whether you came or not”

If the negation in the embedded clause could be shared, the sentence would mean “I do not know if you did not come or did not come”, which is impossible.

Also, my judgement is that the NPI *hiçbir* cannot be licensed in the first clause but it can be licensed in the second one:

- iv.       Çeşitli soru -lar sor-up hiçbir -ne cevap ver -me -di -Ø  
 Various question-PLU ask-IP any one-DAT answer give-NEG-PAST-3SG  
 “He asked various question and did not answer any of them”
- v.       \*Hiçbir soru-yu sor-up cevap ver-me-di-Ø  
 Any question-ACC ask-IP answer give-NEG-PAST-3SG  
 “He did not ask any question or answered them”

This implies that in such constructions, negation is not shared between the two clauses. This issue is far from settled. I leave it open here. I will continue to assume that verbal items cannot be coordinated in Turkish.

33. a. \*Oku mu du -n?

read Q PAST-2SG?

Int. "Did you READ?"

b. \*Oku-ma mi -di -n?

read-verb.NEG Q-PAST-2SG

Int. "Did you not read?"

c. \*Oku-du mu-n?

read-PAST Q-2SG

Int. "Did you read?"

A tree representation of (33) could be (34). However, for some reason, this derivation does not converge:

34.

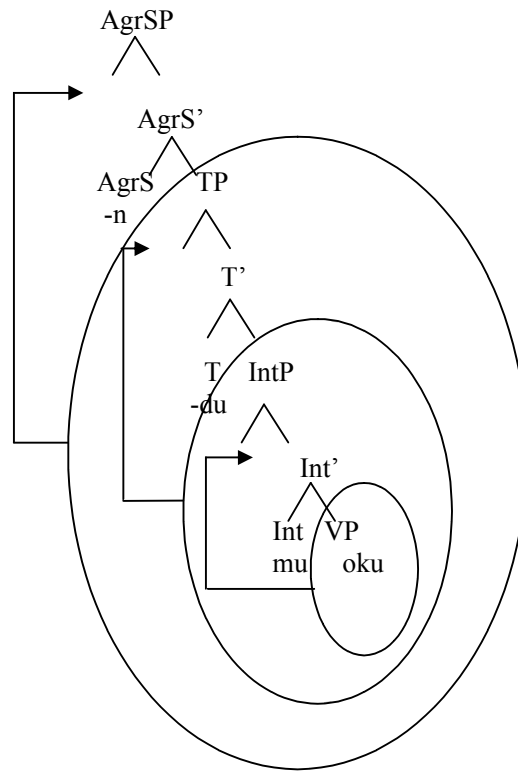

On the other hand, a verbal complex headed by a non-verbal affix can occur at the specifier of the question particle, as noted in Kornfilt (1996 p. 106):

35. Gel-ecek mi-siniz?

come-FUT Q-2PL?

“Will you come?”

It seems that constructions headed by verbal items cannot move phrasally in Turkish and they cannot coordinate as would be expected from phrases. These observations seem to suggest that the way verbs and verbal G1 and G3 suffixes behave shows the characteristics of suffixation via head-movement rather than cliticization by phrasal movement. This is unexpected in the antisymmetric models. This is because, if we assume an underlying head-initial structure, the head-movement of the verb to T (and then maybe to Agr) results in the verbal complex being in a relatively high position. This means that all the phrases below T should be lower than this complex. In such a scenario, all the morphemes that are below the T head would follow the verbal complex. This would make Turkish an ‘S V-T-AGR (adv<sub>1</sub>) obj (adv<sub>2</sub>)’ language (say, an SVO language). However, Turkish is ‘S (adv<sub>1</sub>) obj (adv<sub>2</sub>) V-T-AGR’ language.<sup>16</sup> To my knowledge, other than cases postulated by the requirements of antisymmetry, there does not seem to be independent evidence for VP movement in Turkish.<sup>17</sup>

I assume that these observations indicate that an analysis that interprets affixation as resulting from a series of phrasal movement does not quite work in some cases of Turkish verbal morphology. That is, Turkish poses empirical challenges to antisymmetric

---

<sup>16</sup> Note that Adv<sub>1</sub> is higher than Adv<sub>2</sub>.

<sup>17</sup> See Kural (1997) and Öztürk (in press) for arguments against an antisymmetric analysis of Turkish.

approaches based on phrasal syntactic movements. This conclusion will be crucial in discussing an alternative proposal.

## CHAPTER 4: MIRROR THEORY AND SUFFIXHOOD

### 4.1. The General Picture So Far

It is important to remind ourselves of the problems that we are faced with so far:

- a. X-bar Theory makes it difficult to capture V-X as a reflex of syntax as it allows both verbal and non-verbal items to occupy similar positions (i.e. the complement and the specifier position) with respect to a functional morpheme. This, then, makes it difficult to understand why a functional morpheme in a certain relation to a verbal projection shows suffixal character while a functional morpheme in the same relation to a non-verbal projection need not be a suffix.
- b. An X-bar Theory plus Head Movement approach to suffixhood requires some assumptions that are not well-motivated. The assumption that an uV feature is always strong does not follow from anything. The evidence for the syntactic nature of head movement of Neg faces empirical problems.
- c. Turkish verbal items do not seem to be moving phrasally as antisymmetric models would predict. Their behavior is more like true suffixation via head-movement (although, I would like to claim that this movement is postsyntactic).

I will present further evidence against X-bar Theory later. What we seem to need, now, is an alternative conception of phrase structure - one that is able to make a distinction between the syntactic representation of verbal and non-verbal objects. I will argue that Brody's Mirror Theory (Brody, 2003) is a good candidate to do so. In an antilexicalist interpretation, it has the advantage of reducing suffixation to a deterministic reflex of

syntax. In this implementation, it also makes some strong predictions about the behavior of verbs and verbal morphemes, which are borne out as far as Turkish is concerned. In the next section, I will introduce the basic tenets of Mirror Theory.

## 4.2. Mirror Theory

Mirror Theory (Brody, 2003) is a theory of the morpho-syntax interface that attempts to relate morphological structure directly to syntactic relations. In this system, a syntactic relation of complementation between X and Y is directly associated with the morphological word that X and Y form together. This is secured by Mirror, which says:

36. Mirror (Brody, 2003 p. 218)

The syntactic relation “X complement of Y” is identical to an inverse order morphological relation “X specifier of Y”.

An axiom that Mirror borrows from the antisymmetry theory of Kayne (1994) is that specifiers always precede the objects that they are specifier of. This is also true in morphology. The morphological relation in which X is a specifier of Y is the one in which X precedes Y word-internally. More informally, it refers to the case in which Y is suffixed to X. It should be noted the morphemes that constitute a word must be spelled out in the order that is determined in morphology and Spell-Out directly reflects the precedence relations that are specified at the level of morphology.

Another axiom of Mirror Theory is the Telescope Hypothesis. According to the Telescope Hypothesis, “a single copy of a lexical item can serve both as a head and as a

phrase” (Brody, 2003 p. 216). How is this to be represented? Consider the tree below (from Brody, 2003 p. 206):

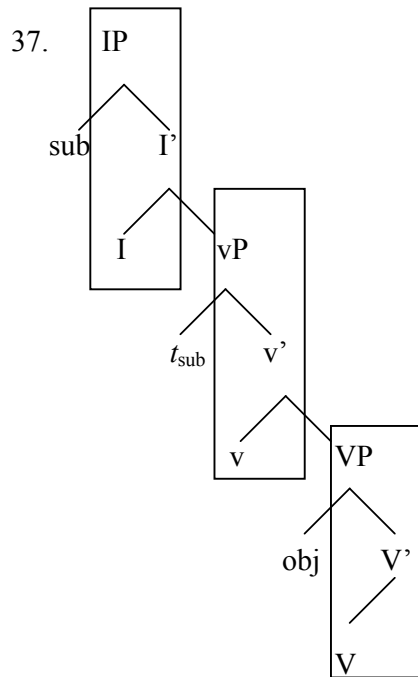

Let us call each line of ‘V-V’-VP’, ‘v-v’-vP’ and ‘I-I’-IP’ a projection line, following Brody. Telescope basically eliminates the distinction between XP, X’ and X of X-bar Theory and reduces them to X only. This gives us the structure below:

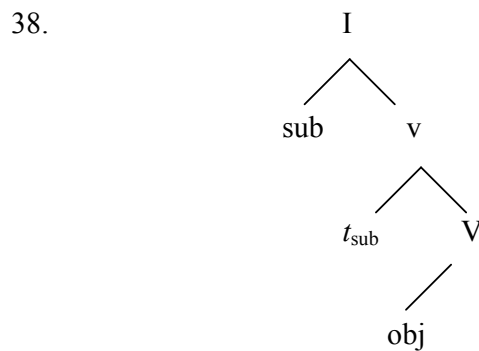

The claim that a single lexical item can function both as a head and as a phrase basically eliminates the notions of head and phrasal projections of a lexical item. This, of course, brings up the question of how to express head-to-head relations as opposed to phrasal relations if there is no such thing as a head or phrasal projection.

In Brody's system, whether a lexical object will show head-like behavior or phrase-like behavior in syntax is dependent on the position that it occupies in syntax. A lexical item shows the behavior associated with a head (for example, it forms what is called head-chains in X-bar terminology) if and only if it occupies a complement position. This is the case with the lexical object X in the structure below:

39. X is the complement of Y in syntax

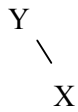

An object shows behavior associated with phrases (forming phrasal chains etc.) if and only if it occupies a specifier position. This is the position that X occupies in the representation below:

40. X is the specifier of Y in syntax

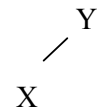

It is now possible to express the difference between head-to-head relations and phrasal relations without the need to assume that a lexical object projects head and phrasal

projections as distinct from the lexical item. If a lexical object occupies a complement position (as in 39), then it forms a head-to-head relation (in X-bar terminology) with the lexical object immediately above it. If a lexical object occupies a specifier position (as in 40), then it may form phrasal chains (for example, it may undergo phrasal movement).

The important issue to realize is that Brody basically eliminates the operation *Project*. Brody proposes a way of expressing head-like and phrase-like behavior without assuming that there is a head projection and a phrasal projection of a lexical item as distinct from the lexical item itself. In (39) and (40), we see that the same lexical item X can be involved in a head-like relation with the object above it as in (39) or a phrase-like relation as in (40), depending on whether it is a complement or a specifier. The next question is, then, what determines whether X occupies a complement position (as in 39) or a specifier position (as in 40).

By Mirror, Brody argues that the morphological relation in which X is specifier of Y (i.e. in which X precedes Y word-internally) licenses the syntactic relation in which X is complement of Y.

Let us give an example of what this looks like. We know that in English the verb and the past tense inflection forms a morphological word in which the verb precedes the past tense morpheme word-internally:

41. walk-ed

For Brody, this means that at the level of morphology, the verb is the specifier of the past tense morpheme as in:<sup>18</sup>

42. In Morphology

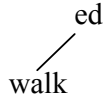

Mirror indicates that the morphological relation in (42) is identical to the syntactic relation in which the verb *walk* is the complement of the past tense morpheme *-ed* as in:

43. In Syntax

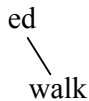

It should be noted that since the Spell-Out reflects precedence relations in Morphology, the verb *walk* will precede the past tense suffix *-ed* at Spell-Out (i.e. this complex will be spelled out as *walk-ed*).

Now let us consider the case of the Turkish non-verbal negation marker *değil* ‘not’:

44. Hasta değil-Ø

sick NEG-3SG

“S/he is not sick”

---

<sup>18</sup> Whether Brody assumes hierarchy at the level of morphology or not is not clear to me. If there is no hierarchy in morphology, this morphological relation could be expressed linearly. For ease of exposition, I will use the convention in (42).

Let us focus on the relation between the adjective *hasta* ‘sick’ and the negation marker *değil* ‘not’. It seems that they do not form a morphological word. The adjective *hasta* ‘sick’ does not precede the negation marker *değil* ‘not’ *word-internally*. Therefore, the word *hasta* ‘sick’ cannot be the morphological specifier of *değil* ‘not’. The relation in morphology cannot be as given below:

45. In morphology

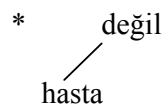

If the adjective *hasta* is not the morphological specifier of the negation marker *değil*, then it cannot license the syntactic relation in which the adjective is the complement of the negation marker. Then, their syntactic relation cannot be as in:

46. In Syntax

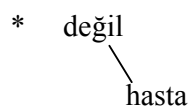

Therefore, it should be the case that the adjective is the syntactic specifier of the negation morpheme as in:

47. In Syntax

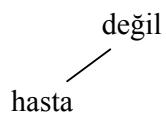

This means that if we have two lexical objects X and Y, it is only when X is the morphological specifier of Y (i.e. X precedes Y word-internally) that X can be syntactic complement of Y as is shown below:

48. In Morphology

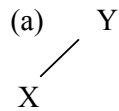

In Syntax

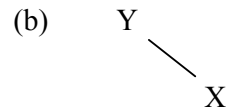

Basically, the licensing of (b) is dependent on the presence of (a) in morphology. That is, (b) can be licensed in syntax if and only if (a) exists at the level of morphology. Therefore, in a scenario where X is not the morphological specifier of Y (consider the case of Turkish non-verbal negation as in 44), (b) cannot be the representation of X. In such a scenario, X must be a specifier (and not a complement) in syntax. More precisely, when two objects are in a local relation and when they do not form a morphological word, then we are sure that one of them is the specifier of the other in syntax and that neither of them is the complement of the other.

### 4.3. Deriving Word Order in Mirror Theory

There is now the question of how this structure is to be spelled out in terms of word order. First of all, we must say that the word-internal order of morphemes is fixed in morphology. Spell-Out of morphological words reflects the precedence relations formed in morphology.

However, when it comes to determine the precedence relation among words, syntactic precedence relations become crucial. In syntax, a specifier always precedes the

complement that it is specifier of. Also, as far as I understand from Brody's discussion, a lexical item precedes its complement and everything in the specifier of its complement.

Within this system, Brody captures word order variation by assuming that the morphological words can be spelled-out at any element that constitutes them. That is, the morphological word V-v-I (as in *love-s* in English) can be spelled-out at V, v or I. That depends on which morpheme is strong in a particular language. Let us see how this spell-out mechanism works to derive SVO and SOV order.<sup>19</sup>

Consider now the tree in (49). A language in which this structure is licensed must be a language in which morphologically, V is the specifier of v, which, in turn, is the specifier of I (i.e. a language in which V-v-I forms a word). The word V-v-I will be spelled out at the strongest item that constitutes it. I will first calculate syntactic precedence relations in the tree below and then show how word order differences are expressed by making reference to the strength of items.

49.

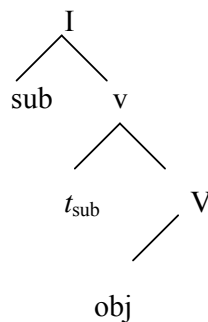

We have two axioms. The first one is that specifiers precede the objects that they are specifier of. The second one is that an object precedes its complement and everything that

---

<sup>19</sup> This section is based on my own understanding of Brody. It may be the case that the way I use the terminology is not exactly what Brody intended to express. The reader is referred to his text for the original claims.

is in the specifier of its complement. Let us now see what this means for the precedence relations in the tree in (49). We work our way up in the tree.

First, since the object is in the specifier of V, the object precedes V:

50.  $\text{obj} > V$

Little v takes V as its complement. Therefore, little v precedes V and everything in the specifier of V:

51.  $v > \text{obj} > V$

Since the specifiers always precede the objects that they are specifier of, the trace of the subject precedes v and everything that v precedes:

52.  $t_{\text{sub}} > v > \text{obj} > V$

I(nflection) takes little v as its complement. Therefore, I precedes v and everything in the specifier of v:

53.  $I > t_{\text{sub}} > v > \text{obj} > V$

Given that specifiers always precede the items that they are specifier of, the subject precedes I and everything that I precedes:

54.  $\text{sub} > I > t_{\text{sub}} > v > \text{obj} > V$

These are the precedence relations calculated from syntactic relations. We have noted that the morphological relations cannot be disrupted at Spell-Out. That is, V-v-I must be spelled-out as a word even though its components are located in different parts of the serialization in (54).

Brody argues that the position where the V-v-I complex will be spelled-out is subject to cross-linguistic variation. This complex may be spelled out at any of the items that constitute this morphological word. The item that spells out this complex is said to be strong. This is expressed with the sign '@'. Let us assume that in a particular language it is V that is strong.

55. sub > I >  $t_{sub}$  > v > obj > @V

In this language, the precedence relations will be as in (56). For ease of exposition, I will strike out the items that are not the positions for spell-out.

56. sub > I >  $t_{sub}$  > ~~v~~ > obj > V-v-I

The spell out order of this complex will be

57. sub > obj > V-v-I

This is a SOV language like Turkish. Let us go back to the precedence relations as calculated in the syntax and consider the word order in another language. Let us assume that in this particular language the strong element is little v.

58. sub > I >  $t_{\text{sub}}$  > @v > obj > V

In this scenario, the complex V-v-I will be spelled out at little v:

59. sub > I >  $t_{\text{sub}}$  > V-v-I > obj > V

The spell-out order of words in this language will thus be:

60. sub > V-v-I > obj

This is a SVO language like English.

In other words, word-order differences among languages are expressed by making reference to the strong item that spells out the whole morphological word.<sup>20</sup>

It should be noted that although I tried to give an explicit discussion of the spell-out mechanism of the Mirror Theory, this system will not have too much importance for the kind of answers I am after.

We have noted that, in the way Brody builds up his system, the relation between a morphological word and syntactic complementation is that of licensing. That is, the relation where X is the complement of Y in syntax is licensed by the fact that in the lexicon there is a word in which X is the morphological specifier of Y. Remember examples between 41 - 47 in which the fact that, in English, the verb *walk* precedes the past tense

---

<sup>20</sup> I need to address an issue that is unclear to me. I fail to understand the exact relation between morphological items and syntactic items in Brody's system. Are they the same objects or are they different objects? If morphological items are also the items that syntax manipulates, then it seems to me that we actually need two Mirrors. We need one Mirror that will convert the morphological specifier relations into syntactic complementation relations and then another Mirror that will convert syntactic precedence relations back to morphological relations at Spell Out. If there is only one Mirror, then we need to assume that syntactic objects are distinct from morphological objects and that syntactic objects are only licensed by morphological objects. However, the precedence relations in syntax between the items that form a morphological word are irrelevant for Spell Out.

morpheme *-ed* word-internally was the reason why the verb *walk* occupies the complement position of *-ed* in syntax as opposed to the case in Turkish where since the adjective *hasta* and the negation *değil* does not form a morphological word, the adjective *hasta* is in the specifier position of the negation *değil* in syntax rather than in its complement position. The basic idea is that certain syntactic configurations are licensed by the fact that words that license them exist in the lexicon. The notion ‘morphological word’ is given the causal power of licensing a syntactic configuration.

#### 4.4. Mirror as Spell-Out (Adger, Harbour and Watkins, 2009)

Assuming that V-X is a true generalization about Turkish, Brody’s licensing approach to the relation between morphology and syntax does not offer any immediate insight as to why this should be the case. In this approach, the facts of morphology are taken to be primitives. They are not reducible to anything else. The question we are after is whether V-X can be reduced to a difference between the syntactic representation of verbal items and that of non-verbal items and we would like to derive the suffixal status of the morpheme immediately above the verb from this difference.

Adger, Harbour and Watkins (2009) take advantage of Mirror Theory in explaining what they call ‘inverse base effects’ in the language Kiowa. The important part of their discussion for this thesis is that, unlike Brody, they never make reference to ‘wordhood’ in order to explain what makes a syntactic configuration licit. That is, the existence of a certain word in the lexicon is not a prerequisite for a particular syntactic structure to be licensed. Although they do not present an explicit discussion of this issue, it seems that they consider Mirror to be a spell-out mechanism (David Adger, p.c.). That is, the syntactic configuration in which X is the complement of Y is *realized* at Spell-Out by the suffixation

of Y to X. In this proposal, suffixation (in head-relations) is a reflex of a certain syntactic configuration (and not part of the lexical knowledge). Let me express this position as below:

#### 61. Mirror as Spell-out

The syntactic relation “X is the complement of Y” is realized at Spell-Out from Syntax to PF by suffixation of Y to X (i.e. as X-Y).

For this antilexicalist interpretation of Brody’s Mirror Theory, a question remains to be answered. In Brody’s system, we know that a grammatical object is a specifier of another object when we see that it does not form a morphological word with it. However, in the antilexicalist reading, we are not allowed to make reference to wordhood as a possible indicator of configuration as this is not what syntax is sensitive to. Wordhood, here, should follow from the syntactic configurations that morphemes take part in. What we need is independent syntactic evidence that an object is in a certain configuration. This, then, requires a closer look into the nature of complements and specifiers in Mirror Theory.

#### 4.5. A Proposal for Mirror as Spell-Out

In this section, I would like to explicate a syntactic interpretation of positions made available by Mirror Theory and I would like to propose certain tests that will indicate what position a lexical object occupies. This will be crucial for explaining V-X in Turkish.

We have two basic configurational possibilities: complementhood and specifierhood. What is the nature of objects that can be in a complement position or in a specifier position? What I would like to argue is this: a lexical object occupies a specifier



Following Kayne (1994), I will take it to be true that an object is a phrasal object if it can be coordinated.

Following Rizzi (1997) and Kayne (1998), I will assume that focus, topic and focus-related heads trigger movement to their specifier position (following Kamali (2011), I take the question morpheme *-mI* to be a focus-related morpheme whose specifier must be filled). With the assumption that movement to a specifier position marks phrasal behavior, I will assume that any object that can be questioned, focalized or topicalized by movement is a phrasal object.

Any object that passes one of the tests described above is an object that occupies a specifier position.

#### 4.6. A Mirror Theoretic Explanation to V-X

Now, we are equipped enough to take steps towards an explanatory theory of our V-X observation in Turkish.

There are two logically possible syntactic configurations that any lexical item, including a verbal item, can take part in. It can be a specifier (63a) or it can be a complement (63b).

63. V as a specifier

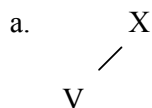

V as a complement

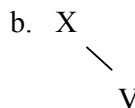

The configuration in (63a) is the one in which a verb is in a specifier position (i.e. shows phrasal behavior). The second one (63b) is the case where the verb is a complement. X

cannot be a suffix in (63a) since Mirror does not apply here. However, if the configuration in (63b) is the one that verb and verbal stems take part in, then X has to be realized as a suffix on V at the spell-out via Mirror. V-X would be explained as a direct reflex of syntax.

The question is this: Can verbs or verbal items behave as phrases (i.e. can they be specifiers)?

Let us start with verbal roots. In discussing the problems with antisymmetric theory, we have seen that unlike phrases, verbal roots cannot be coordinated (repeated from (32)):

64. \*[oku ve anla] -dı -m  
read and understand-PAST-2SG

Int. “I read and understood it” (Kornfilt, 1996 p. 111)

We have also seen that unlike phrases, they cannot move to the specifier of the question morpheme (repeated from (33)):

65. \*gel mi di-n?  
come Q PAST-2SG?

Int. “Did you COME (or did something else)?”

Aslı Göksel (p.c.) points out that there are certain structures in Turkish that may require a “verbal item-topicalization” analysis:

66. [<sub>VP</sub>Şimdi kalk, giyin, okul -a git] <sub>t<sub>VP</sub></sub> yap -a -ma -m valla  
 now wake-up get-dressed school-DAT go do-ABIL-NEG.PRE-1SG EXCL  
 “Now wake up, get dressed and go to school, I just cannot”

Such structures are potential problems for the claims of this thesis for two reasons. This structure is a problem not only as a possible case of verbal-item movement but also as a possible case of verbal item coordination. I argued that since verbal items cannot show phrasal behavior, they cannot undergo phrasal movement and they cannot be coordinated. An alternative analysis that shows that these objects are not verbal must be possible here.

Note that the assumption that the coordinated complex has moved from the main clause is difficult to illustrate as this is a case of string vacuous movement. The base-generated position and the moved position of the coordinated complex are difficult to differentiate. But it is clear that this looks like a case of coordinated verbal items.

What I would like to argue is that the verbs that seem to be fronted are not uninflected as the claim above makes them to be. They are actually inflected with a zero imperative morpheme, which is null in Turkish:

67. Gel -Ø!  
 come-IMP.2SG  
 “(You) come!”

If these verbs are in their imperative form, then there must be an overt or covert second person subject that can license a second person anaphor. That seems to be true:

68. Soru -lar -1 kendin hazırla-Ø, cevap -lar -1 kendin  
question-PL-ACC yourself prepare-IMP.2SG answer-PLU-ACC yourself  
ver-Ø, yap -a -ma -m valla!  
give-IMP.2SG do-ABIL-NEG.AOR-1SG EXCL

“Prepare the questions and answer them yourself! I just cannot do it”

This also casts doubt on the possibility that the imperative marked complex is displaced from the main clause as in (66). If that analysis were true, it would be a mystery how a second person anaphor is licensed in this construction. More importantly, a first person anaphor cannot be licensed:

69. \*Soru -lar -1 kendim hazırla, cevap -lar -1 kendim ver,  
question-PL-ACC myself prepare answer-PLU-ACC myself give,  
yap -a -ma -m valla!  
do-ABIL-NEG.PRE-1SG EXCL

“Prepare the questions and answer them myself! I just cannot do it”

Even if the right analysis for (66) turns out to be a movement analysis, this movement cannot be a case of VP movement. It is movement of a complex headed by a morpheme that includes imperative and second person features in it. Also, the material that is coordinated in (66) is not verbal items. It is a case of coordination of verbs inflected by imperative rather than the uninflected verbal roots. I assume that the morpheme that is the exponent of imperative and second person features is not a verbal morpheme itself.

All these observations point to the conclusion that the verb in Turkish does not behave like a phrase in terms of movement and coordination. Rather, its behavior is more

like that of heads. Then, we conclude that verbal roots occupy a complement position in a Telescopic Syntax, which gives us:

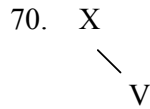

Following Mirror, X has to be realized as a suffix on V at Spell Out. This is the explanation that I propose for the observation that the morpheme immediately above the verbal item is always a suffix in Turkish. Since verbal items can only occupy a complement position, it could not be otherwise. This gives us the Table 1 repeated below:

Table.1. Turkish Suffixes on the Verbal Root

Glosses	Existent Structures Suffixation	Non-existent Structures Free Morphemes
Verb-PAST	gel-di <sub>G3</sub>	*gel di
Verb-COND	gel-se <sub>G3</sub>	*gel se
Verb-PROG	gel-iyor <sub>G2</sub>	*gel iyor
Verb-FUT	gel-ecek <sub>G2</sub>	*gel ecek
Verb-PERF	gel-miş <sub>G2</sub>	*gel miş
Verb-AOR	gel-ir <sub>G2</sub>	*gel ir
Verb-NEG-PAST	gel-me <sub>G1</sub> -di	*gel me-di

Consider now the case of verbal G1 suffixes (ex: negation *-mA*). First, we have seen that they do not allow coordination (repeated from (31) and noted in Kabak, 2007: 321).

71. \*[Gel -me ve git -me] -di -m

come-NEG and go-NEG-PAST-1sg

Int. "I did not come and go back"

We have also seen in the discussion of antisymmetry and suffixhood that verbal G1 suffixes do not move to the specifier of the question morpheme, either (repeated from (33)).

71.\*Gel -me mi di -n?

come-NEGQ PAST-1sg

Int. "Did you not come?"

Therefore, verbal G1 negation is just like verbs in behaving like a head rather than a phrase. Then a verbal G1 suffix must occupy a complement position:

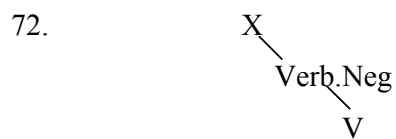

This syntactic configuration has to externalize as V-V.Neg-X. This captures the part of V-X that is relevant for verbal G1 suffixes. They also do not allow free morphemes following them. This gives us Table 2 repeated below:

Table.2 Turkish Suffixes on the Verbal G1 Suffix *-mA*

Glosses	Existent Structures Suffixation	Non-existent Structures Free Morphemes
Verb-Verb.NEG-PAST	gel-me <sub>G1</sub> -di <sub>G3</sub>	*gel-me di
Verb-Verb.NEG-COND	gel-me <sub>G1</sub> -se <sub>G3</sub>	*gel-me se
Verb-Verb.NEG-PROG	gel-mi <sub>G1</sub> -yor <sub>G2</sub>	*gel-mi yor
Verb-Verb.NEG-FUT	gel-me <sub>G1</sub> -yecek <sub>G2</sub>	*gel-me yecek
Verb-Verb.NEG-PERF	gel-me <sub>G1</sub> -miş <sub>G2</sub>	*gel-me miş
Verb-Verb.NEG-AOR.AGR	gel-me <sub>G1</sub> -z <sub>G2</sub>	*gel-me z

Lastly, the same constraints are at work for G3 suffixes (past tense and conditional).

Neither coordination as in (73a) (repeated from 30) nor movement to the specifier of the question morpheme as in (73b) (repeated from (33)) is possible with them (Kornfilt, 1996):

73. a. \*[Gel -di ve git -ti] -m  
 come-PAST and go-PAST-1SG

Int. “I came and went back”

b. \*Gel -di mi n?

come-PAST Q 2sg

Int. “Did you come”

G3 suffixes behave exactly like bare verbs and verbal G1 suffixes in this respect. It is reasonable to assume that they also form head-relations and they have the structure in (74). Since this structure has to be realized in the V-G3-X order via the Mirror Hypothesis, this gives the expected result in Table 3 (where X can only be agreement for some reason).

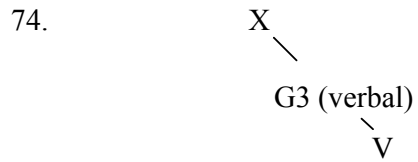
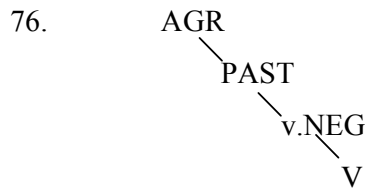

Table.3 Turkish Agreement Suffix on the Verbal G3 Suffixes

Glosses	Existent Structures Suffixation	Non-existent Structures Head-Final Free Morphemes
Verb-PAST(V)-1SG	gel-di <sub>G3</sub> -m	*gel-di m
Verb-COND(V)-1SG	gel-se <sub>G3</sub> -m	*gel-se m

Note also that V-G1-G3-X complex is also possible as in (75) with the representation of (76):

75. Gel -me -di -m  
 come-NEG-PAST-1SG  
 “I did not come”



In short, the explanation for V-X is the one below:

77. The explanation

V-X holds true because the verbal items occupy a complement position (and never a specifier position) in Turkish and a complementation relation where V is the complement of X must be realized in the inverse order of V-X at Spell Out via Mirror.

In this section, I argued that the suffixal status of the morpheme above the verbal item is related to the fact that verbal items can only occupy a complement position in Mirror Theoretic syntax. Evidence for the claim that verbal items always occupy a complement position comes from the fact that they cannot pass any test of phrasalhood that I introduced in this section.

#### 4.7. A Comparative Evaluation of Mirror and X-bar Theory

It will be good to end this section with a comparative analysis of the X-bar Theory and Mirror Theory in capturing V-X as a reflex of syntax. This will also enable us to remember the problems that motivated the employment of Mirror Theory and to evaluate whether we have been able to find solutions to them.

Firstly, let us consider the claim that V-X observation is correlated with the fact that verbal items cannot show phrasal behavior in terms of movement to a specifier position and in terms of coordination. I was able to express this, in the version of Brody's system that I adopted, by saying that verbal items occupy the complement position and the objects in this position cannot show phrasal behavior. However, the same claim seems to be difficult to express in X-bar Theory. This is because, verbal items always project a phrase in this theory. Therefore, it becomes difficult to explain why an object that always

projects a phrase cannot show phrasal behavior in terms of movement to a specifier position and in terms of coordination. Secondly, the ‘X-bar plus Head-Movement Approach’ to suffixhood could capture V-X only by assuming that an uninterpretable V feature is always strong. We noted that this is an explanation that is in need of another one. There is no reason why an [uV] feature cannot be weak. Thirdly, since the explanation based on strong uninterpretable features was syntactic, I also attempted to see whether there was evidence for the syntactic nature of head movement in Turkish. The evidence I reviewed remained unsatisfactory. This is compatible with my proposal since the way suffixes come together with roots is a Spell-Out phenomenon (i.e. non-syntactic) in this explanation.

I would like to raise one last point without following it to its full consequences. Given that being a suffix is a Spell-Out phenomenon, there may be no level in grammar where the affixal status of a morpheme may be relevant for a derivation. Neither can the affixal property of morphemes be argued to trigger movement, nor can there be filters that regulate the behavior of unbound morphemes. If Mirror is right, being a suffix in Turkish verbal domain is an epiphenomenon of the fact that syntax exists in a telescopic form and that verbal items can only occupy a complement position.

## CHAPTER V: FURTHER EVIDENCE

### 5.1. The Verbal Item Hypothesis

In the last section, I have argued that a constraint such as V-X exists in Turkish because verbal items cannot occupy a specifier position in Telescopic syntax. Evidence for this came from the fact that verbal items cannot behave as a phrase in Turkish. One possibility is that a language in which verbal items can behave as a phrase is not subject to the V-X condition. However, in this section, I would like to see whether a stronger position can be maintained. That is, I would like to see whether it is a universal constraint on verbal items that they cannot occupy a specifier position. If this expectation is met, there is the possibility that it will tell us something about the nature of being a verbal item in general. The hypothesis that I will tentatively propose is the following:

#### 78. The Verbal Item Hypothesis

There is no language in which a verbal item can behave as a phrase (i.e. can be a specifier). Therefore, all languages are subject to V-X.

There are two ways to approach V-X. The first one is to look for verbal items in a language and check whether there is always a suffix on the verb or not. V-X indicates that verbal items must be followed by a suffix whenever there is a morpheme above them.<sup>21</sup> The second one is to look for free morphemes in a language and try to see whether they ever

---

<sup>21</sup> In principle, there may be a structure where the verbal item is the highest object with no material above it. In such a scenario, the verb would be bare and V-X would be irrelevant as there is no X. For reasons that are unclear to me, in the languages that I worked on, this option is not empirically attested. There always seems to be a morpheme above the verbal items and this morpheme always seems to be suffixed to the verbal items.

take complements that are clearly verbal. If they do, this will violate V-X. I will use both tests whenever they are available for a given language.

Assuming that coordination is only possible with phrases (Kayne, 1994 i. a.), one prediction of the current theory is that there can be no coordination of verbal items.

Assuming that movement to a specifier position is possible only with phrases, movement for topicalization, focalization must be impossible with verbal items. Neither should there be movement of a verbal item alone to the specifier of a question-morpheme. In the cases of “VP fronting” (in X-bar terminology), what moves should be the null object that takes the verbal item as its complement (for example, an infinitival marker) rather than the verbal item itself.

In the next sections, I will review data from Japanese, Hindi, Basque and English (in comparison with German) to show that the stronger hypothesis works for these languages, too.

## 5.2. Japanese

### 5.2.1. V-X in Japanese

In the table below, I list the functional morphemes that can be found immediately above the verbal root in Japanese.

Table 4. Japanese Suffixes on the Verb Root (examples from Tsujimura, 2007)

Glosses	Existent Structures Suffixation	Non-existent Structures Free Morphemes
V-NONPAST	tabe-ru	*tabe ru
V-PAST	tabe-ta	*tabe ta
V-CAUS-PAST	ik-ase-ta	*ik ase-ta
V-INF	tanom-i	*tanom I
V-PASS-PAST	sikar-are-ta	*sikar are-ta
V-GER	tabe-te	*tabe te

Japanese seems to obey the constraint V-X. The morpheme immediately above the verb is never a free morpheme or a prefix. It is always a suffix.<sup>22</sup>

A problem for V-X constraint arises when we consider Japanese V+V clusters in (79) (Tsujimura, 2007 p. 169):

79. tabe hazime-ru

eat start-NONPAST

“start eating”

Such cases are problematic for V-X because the higher verbal head *hazimeru* ‘start’ does not seem to be suffixed to the first verbal morpheme *tabe* ‘eat’ (assuming that the second verb is the morpheme syntactically right above the first verb). It turns out, however, that in these structures, the first verb is actually marked with infinitival *-i* as in (80) (Heiko Narrog, p.c.); however, for some reason, this morpheme is phonologically null when it follows a verb that ends in vowel (Tsujimura, 2007 p. 154).

<sup>22</sup> In the next section, we will see evidence that they are not phrasal affixes.

- 80.a. but-i hazime-ru  
 hit-INF start-NONPAST  
 “start hitting”
- b. \*but hazime-ru  
 hit start-NONPAST  
 Int. “start hitting”

What needs to be shown now is that the infinitival marker in Japanese (traditionally called the Renyookei form) is a non-verbal element. Ouhalla (1991) argues that one aspect in which functional items differ from lexical items is that the former have a categorial-selectional (c-selectional) requirement while the latter require semantic selection. As far as functional categories are concerned, as a humble interpretation of Ouhalla’s claim, I will assume the following to be true:

81. There cannot be a functional morpheme such that it can select both verbal items and non-verbal items.

Therefore, if we can show that a functional morpheme that selects for a non-verbal element can also select for the infinitival, we would have evidence that the infinitival itself is also non-verbal. Suzuki (1989) explicitly argues for this position by showing that case markers in Japanese may appear on the infinitival form of the verb:

82. Tanaka-sensei-wa mainichi kofi -o o -nom -i -ni naru  
 TOP every day coffee-ACC HON-drink-INF-DAT Aux  
 “Mr. Tanaka drinks coffee every day” (Suzuki, 1989 p. 376)

Under the assumption that verbal elements cannot get a case marker, infinitive cannot be verbal. We, then, understand why the second verb in (80) does not have to be suffixed to the first V-Inf Complex. Their representation is like:

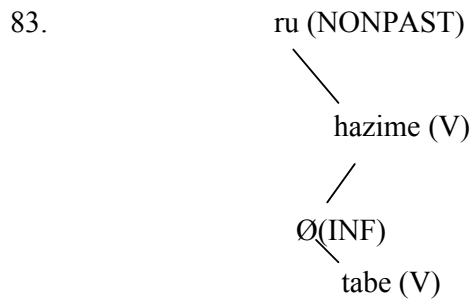

In this section, I argued that V-X constraint is at work in Japanese and that cases in which it seems that the morpheme above a verb is not suffixed to the verb can be analyzed as cases where there is a zero infinitival morpheme on the verb, which does not appear when the verb ends in a vowel.

### 5.2.2. On the Behavior of Verbal Items in Japanese

I have argued that V-X is a true generalization because verbal items cannot occupy a specifier position as a result of which they cannot behave as phrases. There can be neither coordination of verbal items nor so-called “VP” fronting as movement of the verbal items (and what they dominate) alone. In the literature, several cases in Japanese have been argued to show that verbal items *can* be moved or coordinated in this language.

Arguably, Japanese allows “VP” preposing to the spec of the focus particle as exemplified in Kimura (2006 p. 10):

84. [VP Ringo-o tabe]-mo John-ga t<sub>VP</sub> si-ta.  
 apple-ACC eat-ALSO John-NOM do-PAST  
 “John also ate the apples”

As noted in Kimura (2006, citing Kuroda, 1965), this is reminiscent of English do-support. When “verbal” material is fronted, the do-support mechanism saves the derivation by *si* ‘do’ being attached to the stranded Tense affix.<sup>23</sup> However, this analysis is incompatible with the claims of this thesis. Verbal items should not be able to move to a specifier position since this would mean that they can behave as a phrase and that they can occupy a specifier position. Note that the verb “tabe” ends in a vowel and it may be the case that it is still in the infinitival form but the vowel at the end is covert as we have seen in V+V clusters in (80). This would mean that when there is a verb that ends in a consonant, we would overtly see this morpheme. And this seems to be the case (Yasutada Sudo, p.c.):

85. Taroo-ga [uisukii-wo nom-i]-mo si-ta  
 Taroo-NOM whiskey-ACC drink-INF-ALSO do-PAST  
 “Taroo also drank whiskey”

The verb is in its infinitival form when other focus particles trigger movement (Heiko Narrog, p.c.):

---

<sup>23</sup> It should be noted that the do-support phenomenon poses a challenge to my claim that being a suffix is an epiphenomenon. This operation makes reference to the affixal status of a morpheme, which should not be possible. An alternative way of analyzing do-support phenomenon remains a task for future research.

86. Taro-ga [ uisukii -wo nom -i]<sub>j</sub> -sae *t<sub>j</sub>* si-ta  
 Taro-NOM whiskey-ACC drink-INF-EVEN do-PAST  
 “Taro even drank Whiskey”

What moves is then not the verbal item itself but the whole complex with the infinitival suffix. Then “VP preposing” analysis of (84) is not the right analysis for Japanese. This is further evidence for my claim that verbal items cannot show phrasal behavior in Japanese. The representation of (86) would be as in (87):

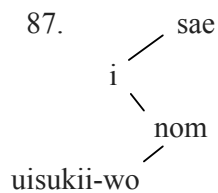

The coordinator in Japanese seems to be the morpheme *sosite* ‘and’. It can be used to coordinate nouns as in (88a) (Yasutada Sudo, p.c.) and adjective as in (88b) (from Namai, 2002: 345).

88. a. John *sosite* Mary  
 John and Mary  
 b. [sizuka *sosite* kirei]-de  
 quiet and pretty-COP

I will assume that *sosite* ‘and’ is the coordinator in Japanese. Yasutada Sudo (p.c.) informs me that it is impossible to coordinate verbal roots with *sosite* in Japanese.<sup>24</sup>

89. a. \*Hanako -ga Taroo-o [but *sosite kusugut*]-ta

Hanako-NOM Taroo-ACC hit and tickle -PAST

Int. “Hanako hit and tickled Taroo”

b. \*Hanako-ga Taroo-o [but *sosite kusugut*]-ru

Hanako-NOM Taroo-ACC hit and tickle -NonPAST

Int. “Hanako hits and tickles Taroo”

c. \*[but *sosite kusugut*]-i

hit and tickle -INF

Int. “to hit and tickle”

A possible problem that arises as far as Japanese is concerned is related to so-called VP-coordination. In the sentence below, the most direct analysis seems to be that there is VP coordination:

90. Taroo-ga kyoo ringo-o tabe *sosite* kinoo koohii-o nom-da

Taroo-NOM yesterday apple-ACC eat and today coffee-ACC drink-PAST

“Taroo ate apple yesterday and drank coffee today”

However, if Japanese allows the coordination of VPs and if coordination marks phrasal behavior, then we have to conclude that Japanese verbal items can show phrasal behavior.

---

<sup>24</sup> I am using verbs that end in a consonant. This is because, when the verb ends in a vowel, the infinitival suffix is null. Therefore, it is impossible to differentiate between the bare form and infinitive marked form of the verbs when they end in a vowel. On the other hand, Yasutada Sudo (p.c.) reminds me that in Japanese a consonant is not a legitimate coda and that there is the possibility that this is the explanation for the ungrammaticality of the cases above.

If this is true, then V-X cannot be a consequence of the fact that verbal items obligatorily occupy a complement position in Mirror Theoretic Syntax. More precisely, V-X cannot be a consequence of the fact that verbal items cannot show phrasal behavior.

One piece of evidence that gives support to the claim that this is a case of VP coordination is the fact that both conjuncts are understood to be in the past tense. In a sense, the past tense interpretation is distributed over both conjuncts. This is precisely what would be expected if this were a case of VP coordination as both VPs would be under the scope of the past tense head. In what follows, I will argue that there seems to be reason to believe that what we have in (90) is not VP coordination.

Consider the sentence below from Kato (2007). Kato indicates that the symbol & below corresponds to what is called ‘invisible coordination’. If this were a case of VP coordination, then the negation head would take both conjuncts under its scope. The interpretation would be the one in which the propositions in both conjuncts are negated. This does not seem to be the case however, as can be seen below.

91. Taroo-ga [kyoo ringo -o tabe] & [kinoo koohii -o nom -ana -katta].

T. -NOM today apple-ACC eat yesterday coffee-ACC drink-NEG-PAST

a. ‘Taroo ate an apple today and didn’t drink coffee yesterday’ (VP<sub>1</sub>&¬VP<sub>2</sub>)

b. \*‘Taroo didn’t eat an apple today and drink coffee yesterday’ (¬(VP<sub>1</sub>&VP<sub>2</sub>))

We realize that this coordination is not as symmetric as it should be in terms of interpretation. The impossibility of the interpretation in (91b) suggests that the negation is not shared between these two conjuncts. It can only affect the interpretation of the second conjunct. In fact, Kato notes that what is called Negative Concord Items (NCI) in Japanese are not licensed in the first conjunct but only in the second one.

92. a. John-ga [kyoo Taroo-o home] & [kinoo dare-mo sikar –ana -katta].

J.-NOM today T.-ACC praise yesterday who-MO scold-NEG-PAST

“John praised Taroo today and didn’t scold anyone yesterday.”

. b. \*John-ga [kyoo dare-mo home] & [kinoo Hanako-o sikar –ana -katta].

J.-NOM today who-MO praise yesterday H. -ACC scold-NEG-PAST

“John praised anyone today and didn’t scold Hanako yesterday.”

Were these examples a case of coordination of “VPs”, such an asymmetry would not be expected. The negation would be shared between two conjuncts. Therefore, I assume that this is not a case of coordination of verbal items.<sup>25</sup> In order to be able understand the nature of this coordination, we need to look closer into the structures.

It should not go unnoticed that the examples in (91) and (92) form another problem for the claims of this thesis. In such examples, it seems that the verb is uninflected. Since there is definitely some material above the verb, the verb being bare is a problem for V-X. We would expect the morpheme immediately above the verb to be a suffix on the verb. It turns out that the first verbal item in this sentence is actually in its infinitival form. When there is a verb that ends in consonant, the infinitival morpheme (Renyoukei form) is observable as can be seen from this example from Fukushima (1999 p. 301)

93. Hanako-ga Taroo -o but -i (sosite) kusugut-ta

Hanako-NOM Taroo-ACC hit-CONJ and tickle -PAST

“Hanako hit and tickled Taroo.”

---

<sup>25</sup> For an alternative analysis, see Kato (2007)

Fukushima notes that what he marks as “conjunctive” is the *Renyookei* (infinitival) form of the verb. We have seen above that verbs marked with this suffix can take ‘dative case’ as in (82), which shows that behavior-wise, they become non-verbal. If *sosite* ‘and’ is the coordinator of these phrases, then what we have cannot be a case of VP-coordination as the first conjunct is not a VP. I tentatively assume that Japanese allows coordination of infinitive and past tense. Of course, this is a topic of great interest for which more need to be said. However, I need to leave this issue as such.

All in all it seems that, in conformity with the expectations of the theory that we are building up, verbal items alone cannot behave as phrases in Japanese and this is why, I claim, this language is also subject to V-X.

### 5.3. Basque

#### 5.3.1. V-X in Basque

Arregi (2000) provides an analysis of the Basque aspect and tense system to give an explanation for the formation of simple and compound tenses in the Basque language. In the meanwhile, he provides a lot of data from Basque that seem to suggest that the V-X constraint that we are argued for is also active in Basque. In the two sentences below in (94), it seems to be the case that there is a suffix on the verb:<sup>26</sup>

94. a. Jon -ek liburu irakurr -i dau

Jon-ERG book read-PERF Aux.PRE

“John has read the book”

---

<sup>26</sup> I have changed the glosses slightly in order to make it compatible with the rest of the paper.

b. Jon asarra -tzen sa -n  
 Jon get.angry-IMPF Aux-PAST

“Jon used to get angry”

(Arregi, 2000 p.2)

If V-X is a true generalization, it should be the case that when there is a free morpheme, its complement is non-verbal. Thus, our hypothesis predicts the perfective and imperfective forms in Basque to be non-verbal. This is because, if the perfective and imperfective marker were verbal elements, then we would expect the auxiliary to follow them as suffix, in conformity with V-X constraint. Crucial for my purposes is Arregi’s observation that the imperfective suffix *t(z)en* is actually bimorphemic. In Arregi’s words, “it contains the suffix *-t(z)e* and the inessive case suffix *-n*” (p.13). If true, this clearly indicates that this is a non-verbal item. As for the perfective suffix, it should be noted that it can be followed by a (delimitative) case marker which gives the interpretation of future tense:

95. Mintza-tu -ko naiz.

speak-PERF-DEL PRE.1S

“I shall speak”

(from Haase, 2007)

With the assumption that only non-verbal elements can get case markers, we have evidence implying that perfective suffix is a non-verbal element in Basque.

In examples in (94), the functional morphemes (*-i*, *-tzen*) above the verb are suffixed to it. Is it the case that other functional morphemes (when they are above the verbal root) are also suffixed to the verb (or verbal suffix)? An observation of Arregi’s is interesting in this respect. Arregi argues that “that both movements [*movements of verbs to the participle heads*, IKB] are the consequence of the following morphosyntactic

requirement: *verbs must have inflection* (emphasis mine)” (p.5). It is well-known that inflectional elements may need verbs to attach to and may trigger head-movement of the verbal item. But the observation that verbs also need inflection in Basque is something surprising and this is in conformity with the expectations of V-X.

Normally, past tense in Basque is expressed by the auxiliary forms as in the following:

96. Mintza -tu nintzen.

    speak-PERF Aux

    “I spoke”

(from Haase, 2007)

I have argued that a free auxiliary in such sentences is possible thanks to the fact that there is a suffix on the verb (here, the participial marker -TU), which is itself non-verbal.

However, Basque has a dozen of so-called synthetic verbs to which the perfective and imperfective suffixes cannot attach. In the absence of these participles, no non-verbal item intervenes between the synthetic verb and the past tense marker. Instead, in these cases, the verb is followed immediately by a past tense morpheme. Then, the prediction would be that in such a scenario, the past tense morpheme is a suffix. This prediction seems to be borne out.

97. Jon-ek liburu ekua -n

    Jon-ERG book have-PAST

    “Jon had a book”

(from Arregi, 2000 p.3)

In this section, I presented evidence indicating that the inflection in Basque language is in conformity with the V-X constraint that I have been arguing for.

### 5.3.2. On the Behavior of Verbal Items in Basque

We have seen above that the Basque cases that we have considered obey the V-X constraint that I have been arguing for. Our theory predicts that this should correlate with the inability of verbal items to behave phrasally in this language. Neither should verbal items be able to move phrasally nor should they allow coordination. In this section, I would like to argue that both of these expectations are met also in Basque.

Ane Odria (p.c.) informs me that a verbal item cannot be followed by a question particle. Under the assumption that this particle triggers movement to its specifier position, we have evidence that verbal items do not show phrasal behavior in such constructions in Basque:

98. \*Maita -al -tzen zenituen?

love(V)-Q -IMPF Aux

Int. "Did you love them?"

Jon Ortiz de Urbina (p.c.) informs me that coordination of verbal roots in Basque is not a possibility either.

99. a. \*Liburuak sal eta maita -tzen ditu

books sell and love -IMP Aux

Int. "s/he sells and loves books."

- b. \*Liburuak sal eta maita -tu ditu  
 books sell and love-PERF/INF Aux  
 Int. “s/he sold and loved books.”

Whether there is VP movement or not in Basque in the context of do-support in this language is explicitly discussed in Haddican (2007). Haddican gives an analysis of do-support phenomenon in the Basque language and argues that an object that can move to a [Spec Foc] position must be a [+noun] in this language.

Haddican shows that the focalized items in Basque move to a designated position at syntax. This is the position immediately left adjacent to the main verb (that bears the aspectual marker) and the position left-adjacent to the negation morpheme *ez* in this language. He, then, gives evidence showing that the position of the focalized main verb is the same position as other focalized items in Basque. This is a position that cannot be occupied by unfocalized items. By this, he argues that the focalized verbal complex actually moves to a designated [Spec Foc].

In the environment of do-support in Basque, the main verb that moves to [Spec Foc] is inflected with the infinitival suffix, which is one of the suppletive forms of what Arregi calls the perfective morpheme *-TU* in Basque. Haddican argues that the perfective suffix *-TU* is actually a nominal infinitival in Basque. Its aspectual interpretation is provided by the movement of verb-infinitive complex to a null aspectual head.

Haddican further argues that what moves in Basque in the context of do-support is not the verbal item itself but the infinitival complex as in:

100. Ines [InfP etorr -i] egin -Ø t<sub>InfP</sub> da.

Ines come-INF do-PERF AUX

a) Ines has COME.

b) \* Ines has come, (non-verb focalization reading)

The exact details of the proposal are immaterial to the thesis. If we follow Haddican in this claim that the infinitival marker is a [+noun] element in Basque, what we see here is that what moves to [Spec Foc] in Basque in the context of do-support is a nominal element. In fact, Haddican states this as a constraint:

101. C(entral) and W(estern)Basque/Korean:

“Verbal constituents that move to FocP must be [+noun], i.e. be headed by a nominalizing affix.” (Haddican, 2007 p.751)

Haddican, by making reference to Manfredi (1993), notes that “it bears observing that (53) [the constraint in 101, IKB] appears to be more general (and in fact, maybe universal)”.

This constraint accords to the expectations of this thesis since it is further evidence that verbal items do not show phrasal behavior on their own. They can only be pide-piped along with a constituent that is itself non-verbal, here the infinitival marker.

In this section, I presented evidence indicating that the observation V-X in Basque is correlated with the fact that Basque verbal items cannot show phrasal behavior in terms of phrasal movement and coordination.

## 5.4. Hindi

### 5.4.1. V-X in Hindi

In this section, we will see what evidence can be amassed to show that Hindi obeys the V-X constraint. Below is a list of morphemes that appear immediately above the verb.

Table.5 Hindi Suffixes on the Verb Root (from Kumar, 2006)

Glosses	Existent Structures Suffixation	Non-existent Structures Free Morphemes
V-PERF	di-ye	*di ye
V-FUT	likh-egaa	*likh egaa
V-HAB	jaa-taa	*jaa taa
V-INF/GER	jaa-naa	*jaa naa
V-SUBJ	de-N	*de N
V-IMP	aa-o	*aa o

The Table 5 indicates that V-X constraint is at work in Hindi. The second question is this: Is it also true that whenever there is a free morpheme, its complement is non-verbal?

Some evidence that Hindi participles are non-verbal elements come from the facts of gender agreement in Hindi. In this language, gender agreement may appear on adjectives and nouns as noted in Kachru (2006 p. 46, 65):

102. a. kutta

dog

b. kutti

female

103. a. acch-a  
           good.M.SG  
 b. acch-i  
           good.F.SG

Rajesh Bhatt (p.c.) informs me that gender markers cannot appear directly on the verb in Hindi. Therefore, it seems that gender marking is a way of differentiating verbs from non-verbs in Hindi. We observe that gender agreement may appear on gerunds/infinitives (Bhatt, 2005):

104. Vivek-ne [kitaab par:h-nii] chaah-ii  
       Vivek-ERG book.F read-INF/GER.F want-PERF.F.SG  
       “Vivek wanted to read the book.”

Using this test further, we realize that habitual, perfective and past tense markers are also non-verbal in the sense that they are gender marked (Bhatt, 2005 p. 768).

105. a. Mona amruud khaa -tii thii  
       Mona.F guava.F eat-HAB.F be.PAST.F.SG  
       “Mona used to eat guavas.”  
 b. Ram-ne imlii khaa-yii thii  
       Ram.M-ERG tamarind.F eat-PRF.F be.PAST.FSG  
       “Ram had eaten tamarind.”



#### 5.4.2. On the Behavior of Verbal Items in Hindi

As expected in the context of the current theory, Rajesh Bhatt (p.c.) informs me that coordination of verbal items suspending the perfective morpheme is not a possibility in Hindi.

108. \*mEN-ne kitaabeN khariid aur bec-ii thiiN  
I -ERG books buy and sell-PERF.F.PL Aux  
Int. “I bought and sold books”

It is not possible to coordinate verbal roots suspending the infinitive marker.

109. \*aa aur jaa-naa  
come and go-INF  
Int. “to come and go”

Movement of verbal items to the specifier of a focus-related clitic is not a possibility, either.

110. a. \*mE-ne kitaabeN paRh –bhii -ii  
I-ERG books read-ALSO-PERF.F  
Int. “I have also read books”  
110. b. \*mE-ne kitaabeN bec –hii -yaa  
I-ERG books sell-EVEN-PERF  
Int. “I have even sold books”

Interestingly, I have not seen any argument for VP topicalization in Hindi. To the extent that this is true, this may be attributed to the fact that verbal items cannot show phrasal behavior.

In this section, I have argued that the fact that we observe V-X constraint in Hindi is correlated with the fact that Hindi verbal items cannot show phrasal behavior.

## 5.5. English

### 5.5.1. V-X in English

In this section, I will discuss an apparent problem that English poses for the theory that is being developed in this thesis. Then, I will attempt to argue that these problems have solutions that are motivated on independent grounds. The cases from English that are well-behaved in terms of V-X are given in the table below:

Table.6. English suffixes on the verb root

Glosses	Existent Structures Suffixation	Non-existent Structures Free Morphemes
V-GER	jump-ing	*ing jump
V-PAST	walk-ed	*ed walk
V-PASS	see-n	*n see
V-PRE.AGR	walk-s	*s walk

However, English also seems to have bare verbs that are not followed by a suffix. The infinitive is one such case:

111. to     come

INF   verb

This case poses an empirical challenge to the V-X generalization. If it is the case that the infinitive *to* is the morpheme syntactically right above the verb, then we would expect this structure to be realized as \**come-to* with *to* suffixed to *come* and not as *to come*. This problem is replicated with modal + verb clusters as in:

112. He     will come

3SG   FUT   verb

On the surface, it seems that the functional morpheme *will*, which is above the verb, is not suffixed to the verb. It is a free morpheme preceding it.

One escape hatch for the current theory could be that in English, the morphemes syntactically above the verb are not suffixed to the verb because in English verbal items can show phrasal behavior. Assuming that coordination is possible only with phrases, this seems to be true for the verbal items above. They allow coordination.

113. a. to     go   and   come (back)

INF   go   COOR   come

b. I     will   go   and     come (back)

1SG   FUT   verb   COOR   verb   (back)

This would mean that The Verbal Item Hypothesis, which says that all languages are subject to V-X, does not work in English. We, then, lose the possibility of understanding

the nature of being a verb as a configuration-related issue in general. Cross-linguistically, verbs can be either complements or specifiers.

However, a comparative analysis of the sentences in (113) with their German counterparts seems to suggest that such a weakening of the theory may not be necessary. That is, it seems that the cases in which the verb seems to be bare in English are exactly those cases where there is an infinitival suffix in German.

114. a. zu komm-en

to come-INF

“to come”

b. Er wird komm-en

He FUT come-INF

“He will come”

There is, then, the possibility that English verbs are actually suffixed by a zero infinitival suffix. The right analysis of English cases would be this:

115.a. to come-Ø

TO verb-INF

b. He will come-Ø

3SG FUT verb-INF

At this point I should note that, to my knowledge, English is the only language in Romance and Germanic sub-families that systematically lacks an overt infinitival suffix. The assumption that it has one (even though it is null) makes English more similar to other

related languages. For an internalist (and universalist) conception of the language faculty, this would be a positive aspect of the current proposal. Nevertheless, I agree that the claim that there is a zero morpheme in such cases should be accompanied by independent evidence to avoid arbitrary postulation of such objects. I have already given one such piece of evidence from comparative data with German. Is there evidence from English itself that postulation of this zero morpheme is warranted? I believe that there is.

Taking as their starting point the work by Raposo (1987) and Nunes (1995), Hornstein, Martins and Nunes (HMN, 2008) take the infinitival *to* to be a preposition. They use this claim in order to explain the asymmetries between the behavior of active and passive perception verbs. The data they attempt to provide an explanation for are the following:

116. a. John saw/heard/made them hit Fred

b. \*John saw/heard/made them to hit Fred

117. a. \*They were seen/heard/made hit Fred

b. They were seen/heard/made to hit Fred

In the active form, the presence of the preposition *to* gives rise to ungrammaticality. In the passive form, its absence gives the same result. HMN attempt to explain this asymmetry without assuming that the subcategorization frames of the verbs *see/hear/make* differ in their active and passive forms.

They argue that in both cases the verb of the small clause containing *hit* is headed by a zero nominal infinitival T. Following Raposo (1987) for Portuguese and Nunes (1995) for old and modern English, they assume that infinitives are case-bearing projections.

Let us consider the stage of Case Assignment in the derivation of the active sentence “I saw Mary leave” (HMN, 2008 p. 209):

118.

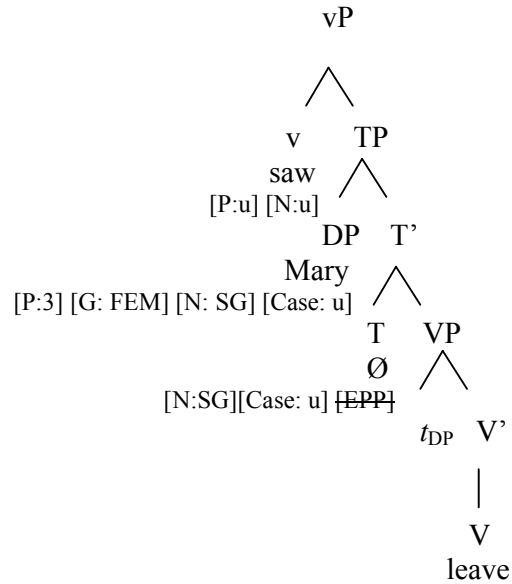

They argue that, by virtue of having an uninterpretable person feature, the matrix light verb *saw* can value Case features of the embedded infinitive and *Mary*. Since *Mary* and the infinitival head are equidistant, both of them can get into a checking relation with the probe matrix *v*. The matrix light verb first agrees with the embedded infinitive head and values its case feature. According to maximization principle of Chomsky (2001), the phi-features of a probe remain unaltered if not all of them are valued at the same time. The infinitive head does not have a person feature to value the unvalued person feature of the matrix light verb. Therefore, the unvalued features of the matrix light verb remain unaltered. The matrix verb, then, enters into a checking relation with *Mary*. The unvalued Case features of *Mary* and all the unvalued features of the matrix light verb get valued. The derivation converges.

Now consider the case with the passive sentence “The girls were seen to leave”

(HMN, 2008 p.213):

119.

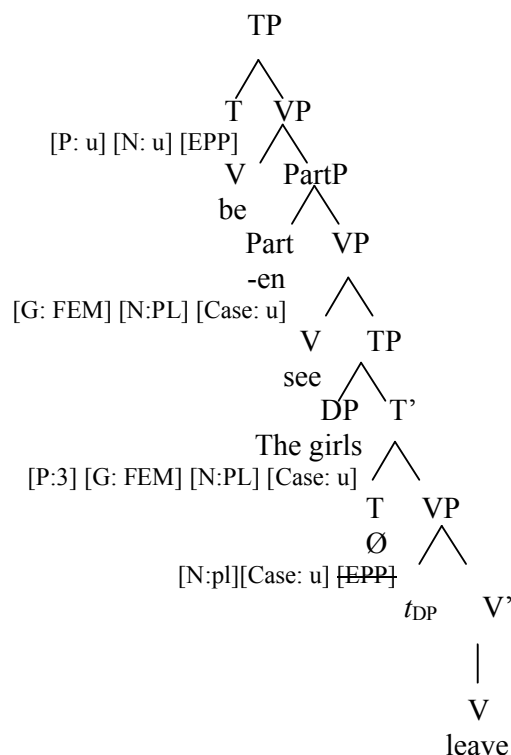

In this configuration, the only case assigner is the matrix T. The participle, the embedded subject *the girls* and the infinitive head have unvalued Case features. The matrix T first values the Case feature of the participle. It remains unaltered according to the maximization principle as the participle cannot value all of the unvalued features of the matrix T. Having unvalued features, the probe continues searching for a target. The participle does not behave as an intervener between the matrix T and *Mary* since the participle does not match all the features of *Mary*. *Mary* has a person feature that the participle lacks. However, the participle does intervene between the matrix T and the infinitive head because it matches the only feature (the number feature) of the infinitive

head. Thus, the infinitive head is not assigned Case. HMN argue that in this case, the preposition *to* is inserted as a case assigner (in a way reminiscent of “of insertion” in the *destruction of the city* versus *destroying the city*).

The analysis of *to* as a preposition is very much in accordance with the claims of this thesis. If it is a preposition, then its complement must be nominal. This can be achieved by the assumption that English bare verbs are actually headed by a zero infinitival suffix.

If *to* were the infinitival head that takes a verbal element as its complement, the similarity between the preposition *to* and this infinitival *to* in English would be just a case of homophony. That there is more than homophony in this similarity is suggested by the fact that in German the same preposition *zu* takes both nouns and verbs headed by an infinitival suffix as its complement.

120. a. *zu-r*      *Schule*

to-DET    school

“to the school”

b. *zu komm-en*

to come-INF

“to come”

In European Portuguese, too, the prepositional item *a* ‘to’ can take an infinitive marked verbs as its complement (HMN, 2008 p.202).

121. O João viu-te a sair.  
 the João saw-CL.2 SG.ACC TO leave-inf  
 “João saw you leaving”

Another argument that English “bare” verbs are actually headed by a nominal infinitival affix can be given by looking at the behavior of the complement of *be* in English. Consider the sentence below:

122. The person who ate the cake was him

We see that the complement position of *be* verb is occupied by an object in accusative case, *him*. Interestingly, “bare” verbs can also occupy this position:

123. All I did was love you

Assuming that verbs do not bear case (but assign it) and that the complement of the verb *be* bears accusative case (as is the case in 122), the complement here cannot be a verb. These data could be explained under the assumption that the bare verb in English is actually headed by a nominal infinitival suffix. It would be argued that it is this infinitival morpheme that bears case.<sup>27</sup> One prediction of this proposal would be that in a language

---

<sup>27</sup> Meltem Kelepir (p.c.) notes that once we assume that bare verbs in English are actually headed by a nominal infinitival element, we need to find an explanation why this complex cannot occupy the subject position as in :

i. \*Live in Istanbul is difficult.

I fail to have an account of why this sentence is not grammatical.

where the infinitival suffix is overt, the corresponding sentences without this suffix should be ungrammatical. This is true, e.g. in German:

124. \*Alles, was ich getan habe, war komm  
All, that I did, was come  
Int. "All I did was come"

In comparable constructions, the verb must bear infinitival suffix in German (Markus Pöchtrager, p.c.).<sup>28</sup>

125. Alles, was ich getan habe, war komm-en  
All, that I did, was come-INF  
Int "All I did was come"

Recall that following Ouhalla (1991), I assume that there cannot be a functional morpheme such that it can take both verbal items and non-verbal items as its complement. The behavior of the English negation marker *not* seems to go against this assumption. It seems that *not* can select both for verbal and non-verbal elements as in (126)

126. a. I will not come.  
b. I am not coming.  
c. Not everybody knows the answer.  
d. I want you not to go.

---

<sup>28</sup> Markus Pöchtrager (p.c.) notes that although this sentence is acceptable to him, it is somehow odd and it is not the most natural way of expressing the idea.

In (126a) the negation marker *not* seems to categorially select for a verbal element. In (126b, c, d) it seems that it also c-selects for a present participle, a quantifier and a preposition. That is, it seems that the negation morpheme in English can select both for verbal and for non-verbal elements.

The claim that English “bare” verbs are actually headed by an infinitival suffix becomes important here. In this scenario, the solution to this problem would be that in the first sentence *not* actually c-selects for a nominal infinitival head. The conclusion would be that, in English, too, there is no functional morpheme such that it can categorially select both for a verbal and a non-verbal item.

Given that *not* selects for a nominal infinitival rather than a verbal item, this also explains why the negation marker in English does not have to be a suffix. If *not* selected for a verbal item, we would expect it to be a suffix in conformity with V-X.

In the following part, I would like to argue that a comparative analysis of languages in which V-X is true by postulating zero morphemes and of languages in which V-X is overtly true indicates that there will (quite probably) be certain asymmetries between these languages.

In Turkish, where V-X is overtly true, we never get a case where a functional head c-selects both for a verbal and a non-verbal item even on the surface. The epistemic modality marker, for example, which can attach to non-verbal items as nouns and participles in (127a, b) cannot attach to verbal items as in (127c).

127. a. O     Ali-dir

He     Ali-EPIS

“He must be Ali”

- b. O gel -miş -tir  
 s/he come-PERF-EPIS  
 “It is probable that he came”
- c. \*O gel -dir  
 he come-EPIS  
 Int: “He probably comes”

On the other hand, if a functional morpheme selects for a verbal item, then it cannot select for a non-verbal item. The imperfective suffix *-Iyor* can only select for a verbal item (128a) and not for a non-verbal one (128b).

128. a. Gel -iyor -um  
 come-PROG-1SG  
 “ I am coming”
- b. \*Kızgın-iyor -um  
 angry-PROG-1SG  
 Int. “I am getting/being angry”

In English, on the other hand, we have seen that the cases where a functional head seems to c-select for both a verbal and a non-verbal element are better analyzed as cases where the verbal item is actually suffixed by a zero nominalizing morpheme. Assuming that what we have argued so far is on the right track, this makes the rule-of-thumb below a way of checking whether V-X is a true generalization in a given language.

129. The Rule-of-Thumb for V-X

In a language where V-X is overtly true (i.e. Turkish and German (leaving aside imperatives)), there cannot be a case where both a verbal and a non-verbal element are selected the same functional head. In a language where V-X is covertly true (i.e. true by postulating zero morphemes like the case with English infinitival suffix), there will (quite probably) be cases where it *seems* that a verbal item and a non-verbal item are selected by the same functional head.

However, although it seems that the verb shares the same complement position with a non-verbal element, this is only apparent. In fact, the verbal item is headed by a non-verbal suffix and this is what causes the illusion that verbs share the same environment with non-verbal items.

Lastly, given that English participles are not followed by suffixes, it must be the case that they are categorically non-verbal. Baker (2005) gives an analysis of English gerund *-ing* as a nominal inflectional element<sup>29</sup> and argues against an analysis of English gerund as a mixed category (i.e. both verbal and nominal). Baker, Johnson and Roberts (1989) argue that the English passive morpheme *-en* functions as an argument that receives case and a theta role. Following Freeze (1992), Kayne (1993) argues that the English possessive verb “have” is derived by incorporation of a preposition to the copula “BE”. He transposes this analysis to the auxiliary “have” and argues that “the two [auxiliary *have* and possessive *have*, IKB] are the same in the sense that both correspond to D/P<sub>e</sub> + BE. (They differ, of course, in that *have* as an auxiliary has a DP complement containing a participle substructure, whereas possessive *have* has a DP complement containing a QP/NP substructure)” (p. 112) With the assumption that only a non-verbal element can be taken as

---

<sup>29</sup> But see also Malouf (2000) and Pullum (1991) for arguments against this position.

a complement by D, the English perfect participle could be analyzed as non-verbal as expected.

In all these analyses, the non-verbal status of participles in English is either implied or explicitly argued for in a way that meets the expectations of the theory in this thesis.

### 5.5.2. On the Behavior of Verbal Items in English

In this section, I will argue that English verbal items do not show phrasal behavior. To the extent that it is true that English verbs are actually headed by an infinitival suffix, many cases of so-called “VP” fronting or “VP” coordination in English must be reanalyzed as movement and coordination of complexes headed by an infinitival element. I will argue that this reanalysis makes it possible to show that predicate fronting in Basque, Japanese and English in the context of do-support is actually more similar than what seems to be the case on the surface.

Let us start with so-called “VP” fronting in English. If it is true that the verb in English is actually headed by a zero infinitival suffix, then the item that moves in the construction below is not the verbal item itself. Rather, the item that moves is the complex headed by the infinitival element.

130. He said he would come with us, and

[<sub>Inf</sub> come-Ø with us], he will *t*<sub>Inf</sub>

This must also be true for predicate fronting in the context of do-support in English. The element that moves is not the verbal item itself. Rather, it is the infinitival element.

131. John said that he would come with us and

[<sub>Inf</sub> come-Ø with us], he did     *t*<sub>Inf</sub>

This claim is especially interesting when we compare it with do-support constructions in Basque and Japanese. In these languages, we have seen that in the context of do-support, the object that is fronted is not the verb itself. Rather, it is the complex headed by a nominalizing infinitival suffix. Let us remember the relevant examples from Basque (132a repeated from 100) and Japanese (132b repeated from 86).

132. a. Ines     [<sub>Inf</sub> etorr -i]     egin -Ø     *t*<sub>Inf</sub>     da.  
         Ines     come-INF     do-PERF             AUX

“Ines has COME”

b. Taro-ga     [<sub>Inf</sub> uisukii -wo     nom -i] -sae     *t*<sub>Inf</sub>     si-ta  
         Taro-NOM     whiskey-ACC     drink-INF-EVEN             do-PAST

“Taro even drank Whiskey”

This means that the category of the object that is fronted in the context of do-support phenomenon in English, Basque and Japanese is actually the same, namely the complex headed by an infinitival marker. Verbal-item fronting analysis for English would miss this similarity.

Another expectation of the current theory is that verbal items cannot be coordinated. That seems to true for English:

133.a. \*I am [come and go]ing back

b. \*I [walk and jump]ed the whole day

The cases in which verbal items seem to be coordinated can be understood as a coordination of verbs bearing an infinitival marker rather than the verbal items themselves.

134. I will [<sub>Inf</sub> walk-Ø] and [<sub>Inf</sub> jump-Ø] the whole day

In this section, I argued that the most promising cases of “VP”-fronting in English must be reanalyzed as the movement of a complex which is headed by an infinitival suffix. What looks like the coordination of verbal elements in English can also be reanalyzed as the coordination of the complexes headed by an infinitival suffix.

All in all, in this chapter of the thesis, I argued that the claim that the morpheme syntactically right above the verb is always a suffix (i.e. V-X) finds empirical support in Japanese, Hindi, Basque and English. I also showed that the presence of V-X constraint is correlated with the fact that verbal items are unable to show phrasal behavior in terms of movement and coordination in these languages. I argued that verbal items cannot be moved to the specifier of any topic, focus or focus-related particle and that they cannot be coordinated in these languages.

## CHAPTER VI: TWO NON-VERBAL ITEMS AND THEIR INFLECTION

### 6.1. The Non-Verbal Item Hypothesis

In the previous chapter, we saw that there is a designated structural position (i.e. the complement position) for verbal items in the telescopic syntax in all the languages we have looked at (and hopefully in any possible human language). The question that will be addressed in this section is whether other objects can occupy this complement position. Two non-verbal objects (nV objects) that I will be looking at will be nouns and non-verbal participles. The question that I will address is whether they occupy a complement position (b) or a specifier position (a) or both.

135. A non-verbal item as a specifier

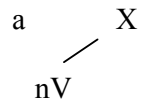

A non-verbal item as a complement

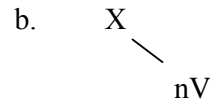

I will try to argue that non-verbal objects always show phrasal behavior. This, then, means that they cannot be in a complement position as in (b). I will argue that such objects always occupy a specifier position as in (a). Clearly, these two objects (nouns and participles) do not exhaust the list of non-verbal items as there are adjectives, adverbs, prefixes etc. I will leave an analysis of such objects for further research. However, I still believe that showing that nouns and participles always show phrasal behavior (in direct contrast with verbal items) will give us clues about the nature of the verbal/non-verbal distinction in grammar.

What does it mean for a non-verbal item to show only and always phrasal behavior?

They should pass at least one test that indicates phrasal behavior. They should allow



If non-verbal elements can only occupy a specifier position, then they can only show phrase-like behavior. And they should not show head-like behavior. The phenomenon of noun incorporation has been argued to be one such case where nouns seem to show head-like behavior. Baker (1988) argues that incorporation phenomena are the result of syntactic head-to-head movement. In the case of noun incorporation, the N head of an NP, which is in the complement position of a V moves and head-adjoins to this V node as a result of which a new V is formed as in:

138. VP

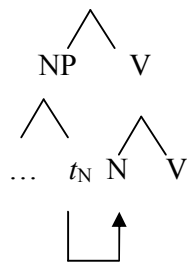

This movement obeys syntactic principles like the Empty Category Principle and this explains, for example, why it is impossible for subjects (or adjuncts) to undergo incorporation. This is so because the trace left by the lowering of the subject to V node would not be properly governed. The head-movement analysis of the direct object to the verb is taken as an explanation for the impossibility of excorporation (a well-known restriction on head-movement) and as an explanation why the verb behaves as a unit with the noun that incorporates into it.

If noun incorporation is a possibility, then, nouns can and in fact must occupy a complement position in Brody's syntax (as they can show head-like behavior). For the theory being developed here to be true, the head-incorporation analysis of noun-

incorporation (as in Baker, 1988) must be shown to be a case of either lexical or phrasal interaction.

In this section, I will basically try to argue that the hypothesis below is true:

### 139. The Non-Verbal Item Hypothesis

A non-verbal item (in this thesis, nouns and participles) occupies a specifier position (and never a complement position) in the sense used in Brody (2003). Therefore, they do not show the syntactic behavior associated with heads (i.e. suffixation, head-incorporation) but they do show syntactic behavior associated with phrases (i.e. coordination, phrasal movement, phrasal affixation).

To the extent that The Non-Verbal Item Hypothesis is true, we will come closer to a structural definition of being a verbal vs. a non-verbal item.

## 6.2. Turkish

### 6.2.1. Non-Verbal Items in Turkish

In this section, I will look at the nouns, participles and the inflection that appears on nouns and participles in Turkish. I will argue that nouns and participles are phrasal objects in Turkish and that their inflection is always phrasal.

That uninflected nouns allow coordination and that they can move to a specifier position in Turkish is clear:<sup>30</sup>

---

<sup>30</sup> The question of how to express coordination best within Brody's system remains as a task for future research.

140.a. Ali ve Ahmet gel -di -ler

Ali and Ahmet come-PAST-3PL

“Ali and Ahmet came”

b. Ali mi gel -di -Ø

Ali Q come-PAST-3SG

“Is it Ali who came?”

The question, then, is whether nouns *always* show phrasal behavior or not. What is their position, for example, when they are followed by a case marker as in (141)?

141. Ben Ali -yi gör -dü -m

I Ali-ACC see-PAST-1SG

“I saw Ali”

There is evidence showing that even in (141), namely where *Ali* is followed by a bound morpheme, the noun actually occupies a specifier position. We argued that coordination marks phrasal behavior. If an item can be coordinated, then it is in a specifier position. The nouns allow coordination even when they are followed by a case marker. This is a case of so-called suspended affixation (Lewis, 1986).

142. Ben [Ali ve Ahmet] -i gör -dü -m

I Ali and Ahmet-ACC see-PAST-1SG

“I saw Ali and Ahmet”

As noted in Kabak (2007 p. 335) (also in Lewis, 1986, and Orgun, 1996), the same seems to be the case with other inflectional elements on nouns:

143. a. Almanya ve Amerika -dan

Germany and America-ABL

“from Germany and America”

b. ev ve dükkan-lar -da

house and shop -PL-LOC

“in houses and shops”

c. Mert ve Can -la

Mert and Can-COM

“with Mert and Can”

d. Arda ve Can -in

Arda and Can-GEN

“Arda and Can’s”

(Kabak, 2007 p. 335)

The situation is no different with the dative case marker in Turkish:

144. [Ankara ve İstanbul] -a uğra -dı -k

Ankara and İstanbul-DAT visit-PAST-1PL

“we visited Ankara and Istanbul”

Therefore, we have evidence that nominal elements show phrasal behavior even when they are followed by inflectional elements.

In the second chapter of the thesis, I talked about suffixes that show verbal behavior, namely G1 and G3 suffixes, and showed they are always followed by a suffix. I have so far postponed a discussion of G2 non-verbal suffixes that are usually referred to as participles. These suffixes are the perfective (and evidential) morpheme *-mİş*, the progressive morpheme *-iyor*, the future tense morpheme *-yAcAk*, the necessitative morpheme *-mAlI* and the aorist morpheme *-Ar/-(I)r*.

One of the bound morphemes that can follow participles is the agreement marker from the z-paradigm (the so-called nominal paradigm of subject agreement, for discussion see Kornfilt, 1996, Kelepir, 2001, Enç, 2004, Good and Yu, 2005).

145. Biz gel -iyor -uz  
we come-PROG-1PL  
“we are coming”

Given that the participle is categorically non-verbal, in the current proposal it should not appear in a complement position. Therefore, it must be in a specifier position. Then, there must be evidence showing that the participles can show phrasal behavior. As is frequently noted (Kornfilt, 1996, Kelepir, 2001, Enç, 2004), the complex headed by a G2 non-verbal suffix allows coordination. In such a scenario, the subject agreement marker from the z-paradigm attaches to the whole coordinated phrase. In (146), the conjuncts share the first person plural subject.

146. Biz [gel-iyor ve gid-iyor]-uz  
 we come-PROG and go-PROG-1PL  
 “We are coming and going”

It should be noted that this is exactly the opposite of what we have seen in the interaction of verbal items with their suffixes. The coordination of verbal items was never a possibility. The fact that it is possible to coordinate non-verbal objects even when they are followed by a bound morpheme is evidence of their phrasal behavior. Given these observations, the affixation of this paradigm of subject agreement is phrasal. Therefore, the correct representation of (145) should be as in (147):

147.       uz  
           /    \  
         iyor  
               \  
               gel

Secondly, the complex headed by the progressive marker can move to the specifier of the question particle and the agreement marker attaches to this particle.

148. Sen gel -iyor mu-sun?  
 you come-PROG Q-2SG  
 “Are you coming?”

These two observations show that complexes headed by the progressive marker (a non-verbal G2 suffix) show phrasal behavior. Hence they must be in the specifier position.

Therefore, the affixation that targets them is not a case of real suffixation (of the kind that the Mirror gives us), but it is a case of phrasal affixation.

Another bound morpheme that can attach to participles (and nominals) is the epistemic marker *-Dir*. In conformity with the expectation of this thesis, objects headed by this G2 suffix can be coordinated even when they are followed by this bound morpheme.

149. Gel -iyor ve gid -iyor -dur  
come-PROG and go-PROG-EPIS  
“Probably, he is coming and going”

Again, movement of the participle into the specifier of the question particle is possible:

150. Gel -iyor mu -dur?  
come-PROG Q-EPIS  
“(Do you think) he is coming?”

As expected, the non-verbal suffixes show phrasal behavior even when they are followed by a bound morpheme. The inflection that follows them is phrasal affixes rather than suffixes. This shows that this is a kind of affixation that is not subject to Mirror.<sup>31</sup>

---

<sup>31</sup> I do not have a proposal about the nature of difference between free versus bound status of the morphemes that are immediately above a non-verbal element. That is, I do not have a proposal as to why Turkish non-verbal negation is a free morpheme following the noun while Turkish case markers are bound morphemes. My theory divides all morphemes into the groups of “suffixes” and “non-suffixes”. It is a question of great interest how finer distinctions among non-suffixal objects (i.e. distinction between phrasal affixes and free morphemes) should be explained.

### 6.2.2. Noun Incorporation in Turkish

Let us discuss the case of so-called noun incorporation of bare objects in Turkish. In the context of this thesis, the prediction is that there cannot be syntactic head incorporation of nouns given that nouns cannot be in a complement position in the first place. Therefore, bare objects cannot be incorporated into a verb.

Knecht (1986) includes an explicit discussion of incorporation of bare objects in Turkish. A canonical example of noun incorporation is given in (151)

151. Ali kitap oku –yor –Ø  
Ali book read-PROG-3SG  
“Ali is doing book-reading”

Knecht notes that, in the case of case-marked objects, bare objects resist displacement, they do not undergo topicalization, they disallow intervention of adverbials, and even non-derived modifiers (which are known to occupy preverbal position (Taylan, 1984)) cannot intervene between the bare objects and the verb (for detailed discussion see Öztürk (2005 p. 34 – 37)). Thus, Knecht concludes, this must be a case of real incorporation in the sense of Baker (1988) (see also Kornfilt, 2003 on noun-incorporation analysis of Turkish bare objects).

Öztürk (2005) argues that a head-incorporation analysis of bare objects in Turkish cannot be the right analysis. Citing Taylan (1986), Öztürk (2005) notes that focus/topic related particles like *–mI*, *–dA* and *bile* can intervene between the bare object and the verb. In the context of this thesis, this is a clear evidence for the phrasal status of the bare objects

as only phrasal items can move to the specifier of focus and question-related heads (the example in (152) is from Öztürk, 2005 p.39).

152. Ali kitap mı oku -du -Ø?

Ali book Q read-PAST-3SG

Ali did book reading!?

Another argument that Öztürk raises against a head-incorporation analysis of Turkish bare objects is that they can be coordinated (The example in (153) is from Öztürk, 2005 p. 39).

153. Ali kitap ve dergi oku -du -Ø

Ali book and magazine read-PAST-3SG

“Ali did book reading and magazine reading”

Turkish bare objects can topicalize under an appropriate discourse context as noted in Öztürk (2009 p. 339) among others:

154. Çayı ben  $t_i$  iç -me -di -m

tea I drink-NEG-PAST-1SG

“I did not do tea-drinking.”

This, also, suggests that bare objects in Turkish show phrasal behavior. Therefore, the head-incorporation analysis of Turkish bare objects cannot be right, which gives further credibility to the claim of this thesis that nouns cannot display head-like behaviors (see

also Arslan-Kechriotis, (2006) and Gracanin-Yüksek & İşsever (2011) on the phrasal status of Turkish bare objects).

### 6.3. Japanese

#### 6.3.1. Non-Verbal Items in Japanese

In this section, I will be interested in the nature of nouns, non-verbal suffixes and nominal inflection in Japanese. I will present evidence indicating that non-verbal items are phrasal objects in Japanese and that the inflection that appears on them is phrasal rather than suffixal.

The first question to be addressed is what the coordinator in Japanese is. Vermeulen (2006) (citing Koizumi (2000 p. 275)) notes that the Japanese particle *to* is generally taken to be a coordinator of nominals as in (155).

155. John-ga [Mary-to Bill] -o mita  
John-NOM Mary-and Bill-ACC saw  
“John saw Mary and Bill.”

Although this confirms the expectations of the thesis, as this is a case of suspended affixation, it seems to me that the analysis of the particle *to* as a coordinator is not clear-cut. Vermeulen notes that this particle cannot be used to coordinate any other category (adjectives for example). This is not what we find with coordinators in Turkish or English. Kotani (2002) notes that this particle is also used in non-coordinating environments with the meaning of ‘with’ and ‘against’.

156. a. John-ga      Mary-to      kita

John-NOM    Mary-WITH    came

“John came with Mary”

b. John-ga      Mary-to              kenkasuru

John-NOM    Mary-AGAINST    fight

“John fights against Mary”

This, then, makes the particle *to* more like a comitative marker than a coordinator. The Turkish comitative marker *ile* also cannot be used with adjectives but can be used in the functions illustrated in (156).

The coordinator in Japanese seems to be the morpheme *sosite* ‘and’. As we have seen in the discussion of verbal coordination in Japanese, this morpheme can be used to coordinate nouns (Yasutada Sudo, p.c.) as in (157a repeated from 88a) and adjectives (Namai, 2002) as in (157b repeated from 88b)

157. a. John *sosite* Mary

John and Mary

b. [sizuka *sosite* kirei]-de

quiet and pretty-COP

Assuming that it is *sosite* ‘and’ that is the coordinator in Japanese and assuming that coordination marks phrasal status, the relevant question is this: Can Japanese nouns be coordinated even when they are followed by bound morphemes? Yasutada Sudo (p.c.) informs me that this is possible:

158. a. John sosite Mary-ga  
           John and Mary-NOM
- b. John sosite Mary-o  
           John and Mary-ACC
- c. John sosite Mary-ni  
           John and Mary-DAT  
           To John and Mary

Further evidence for the phrasal status of nouns in Japanese when they are followed by a bound morpheme is provided by the fact that focus-related particles can intervene between the noun and the case marker (something which is impossible in Turkish) as noted in Vance (1993).

159. Keshigomu dake   -o   mot-te   kita  
       eraser       ONLY ACC   hold-GER   came  
       “They brought only erasers”

Yasutada Sudo (pc) informs me that the focus particle *dake* ‘only’ can also intervene between the noun and other case markers:

160. a. John dake   ga  
           John ONLY NOM  
           “only John”

b. John dake ni  
John ONLY DAT  
"only to John"

In section 5.3, I presented evidence indicating that in V + V compounds in Japanese, the first conjunct is actually headed by a zero infinitival suffix as in (161) repeated from (80a)

161. but-i hazime-ru  
hit-INF start-NONPAST  
"start hitting"

I also argued that this suffix is a non-verbal item in that a case marker can appear on it. Given that this is a non-verbal suffix, there must be evidence showing that it is a phrasal object. For example, it must be possible to coordinate it with other verbs in the infinitival form. Yasutada Sudo (p.c.) notes that this prediction is borne out:

162. tabe-Ø sosite but-i hazimeru  
eat-INF and hit-INF start  
"to start eating and hitting"

In this section, I showed that Japanese nouns show phrasal behavior both when they are bare and when they are followed by a bound morpheme (like case marker). I also provided evidence indicating that the complexes headed by a non-verbal suffix (like infinitive suffix) can show phrasal behavior.

### 6.3.2. Noun Incorporation in Japanese

In this section, I will present evidence from the Japanese literature indicating that a head-movement analysis of noun incorporation in Japanese cannot be the right analysis. To the extent that this is true, the phenomenon of noun incorporation in Japanese will not form counter-evidence to the claim that non-verbal objects cannot show head-like behavior.

An example of noun incorporation in Japanese is given below from Poser (1989):

163. Ainugo        -o        ai        kenkyuu    sita  
Ainu language-ACC   together   research   did  
“We studied Ainu together”

However, Poser (1989 p. 21) notes that there is some empirical evidence implying that the incorporation analysis of these constructions cannot be on the right track. For example, in the context of noun incorporation by head-movement, the noun and the verb must behave as a single unit. However, it is possible in Japanese to delete the noun leaving the verb:

164. Taroo-wa    seikoo sita. Ziroo-mo    Ø sita  
Taroo-TOP   success did Ziroo-ALSO Ø did  
Taroo succeeded. Ziroo did too.

This empirical fact is not compatible with the head-movement analysis of noun incorporation in Japanese. Sells (1995 p.286) also notes that phrasal particles can intervene between the bare noun and the verb in Japanese:

165. a. benkyoo-sae suru

study-EVEN do

'even study'

b. hakken-wa suru

discover-FOC do

'discover (focus)'

These examples show that Japanese nouns cannot undergo incorporation, which is in accordance with my claim that they are always specifiers and never complements in Brody's syntax.

## 6.4. Hindi

### 6.4.1. Non-Verbal Items in Hindi

In this section, I will be concerned with nouns, participles and non-verbal inflection in Hindi. I will present evidence indicating that nouns always show phrasal behavior and that non-verbal inflection is always phrasal.

Nouns can be coordinated in Hindi (Rajesh Bhatt, p.c.)

166. Ram aur Ramesh

Ram and Ramesh

It is also possible to coordinate non-verbal suffixed forms (i.e. participles) in Hindi as is the case with the perfective participle below (Rajesh Bhatt, p.c.). In the example below, the auxiliary *thiiN* is shared between the two conjuncts.

167. mEN-ne kitaabeN khariid-ii aur bec-ii thiiN  
 I-ERG books.F buy-PER.F and sell-PERF.F be.PAST.FP  
 “I had bought and sold books”

It is also possible to coordinate the complexes headed by an infinitival/gerund marker (Rajesh Bhatt, p.c.):

168. aa -naa aur jaa-naa  
 come-INF.M and go-INF.M  
 “to come and go”

Let us now look closer to the nominal inflection in Hindi to see if there is evidence indicating that the nouns are phrasal objects even when they are followed by a bound morpheme. Such structures are explicitly discussed in Butt and King (1999). The examples below show that it is possible to coordinate nouns in Hindi when they are followed by an accusative case marker (in 169a) or an instrumental case marker (in 169b).

169. a. Yasin -ne [kutt -e aur g<sup>h</sup>or-e] -ko dek<sup>h</sup>a he  
 Yassin.M.SG-ERG [dog-M.SG.OBL. and horse-M.SG.OBL.]-ACC see.PERF Aux  
 “Yassin saw the dog and the house”

b. Nadya                                    [lahor or    karac<sup>h</sup>i]-se            he  
 Nadya.F.SG.NOM            [Lahore and Karachi]-INST    Aux  
 “Nadya is from Lahore and Karachi”

Rajesh Bhatt (p.c.) informs me that the Ergative Case can also be shared between two coordinated nouns.

170. [Ram aur Ramesh] -ne  
 Ram and Ramesh -ERG

These facts are in conformity with my claim that nouns can only occupy a specifier position in syntax and can only show phrasal behavior. However, some data from Hindi pose empirical challenge to this claim. As noted in Butt and King (1999), the gender marker in Hindi does not allow coordination of nominals.

171. \* [[kutt                    aur    g<sup>h</sup>or] -e]                    -ko  
 dog                    and    horse-M.SG.OBL -ACC

This fact poses a challenge to the theory being developed in this thesis. Nouns should be able to show phrasal behavior even when they are followed by a gender marker. However, this is not true.

There may be a way to circumvent this problem. We may adopt the idea that agreement is a phenomenon that is triggered by an object that occupies a specifier position (i.e. spec-head agreement following Koopman, 2006 i.a.). Assuming that only phrasal

objects can occupy a specifier position, this would mean that if an object triggers agreement, then this object is a phrasal object.

Then, the fact that nouns in Hindi trigger gender agreement is something that shows that they are phrasal objects. The fact that they fail coordination test of phrasal behavior does not necessarily show that they are not phrasal.

If it were possible for verbal items to trigger agreement, the implications of this test would make the whole thesis untenable. This is so because it would mean that verbal items can also occupy specifier position. For the languages that we were concerned with, we have not seen any case where a verbal item triggers agreement. That is, we have not seen a case where there is an agreement marker that appears on the verb when the verb is ditransitive and another when the verb is intransitive etc. I will assume that this is true in general. This, then, saves the agreement test from overgenerating.

Another piece of evidence indicating that nouns are always phrasal in Hindi is that they can move to the specifier of phrasal particles even when followed by a case morpheme as noted in Butt and King (1999):<sup>32</sup>

172. a. Us -hi -ne kam ki-ya  
He-FOC-ERG work.M.SG.NOM do-PERF.M.SG.  
“That one himself/ only did the work”
- b. Tujh -hi -ko  
You.OBL.-FOC-DAT  
“to you (and not someone else)”

---

<sup>32</sup> There seems to be some dialectical variation in the acceptability of such constructions. Interestingly, in Turkish, such structures are impossible.

c. Saikal-hi-se

Bicycle-FOC-INST.

“with bicycle (focus)”

All in all, nouns and participles in Hindi show phrasal behavior as expected in this thesis. Their inflection is usually phrasal affixation. The problem that Hindi gender marking poses for the claims of the thesis can be avoided by following the assumption that an object that triggers agreement occupies a specifier position.

#### 6.4.2. Noun Incorporation in Hindi

The status of the so-called noun-incorporation in Hindi is explicitly discussed in Dayal (2011). What seems to be an example of noun incorporation in this language is given below (from Dayal, 2011 p. 127)

173. Anu-ne      kitaab paRhii

Anu-ERG book read-PERF

“Anu book-read (read a book)”

However, Dayal argues that Hindi bare objects have phrasal status even when they seem to be incorporated. Incorporated NPs, for one thing, allow coordination (as is the case in Turkish):

174. Anu kutta aur billi paaltii hai  
Anu dog and cat breed-IMPF be.PRES

“Anu breeds cats and dogs”

(Dayal, 2011 p.137)

They also can be scrambled to the topic (or focus) position under appropriate discourse conditions:

175. a. [<sub>F</sub>*kitaab*] Anu becegi, [<sub>F</sub> akhbaar] nahiiN

book Anu sell-FUT, newspaper not

“Anu will sell books not newspapers”

b. *kitaab* Anu bhii becegi

book Anu also sell-FUT

“Anu will definitely sells books” (Dayal, 2011 p.137)

This, then, shows that a head-movement analysis of bare objects in Hindi is not quite correct. This is so because nouns show phrase-like behavior in terms of coordination and movement. This is in conformity with my claim that nouns can only occupy a specifier position, as a result of which they cannot show head-like behavior.

## 6.5. Basque

### 6.5.1. Non-Verbal Items in Basque

It is time now to look at the nature of nouns and participles and their inflection in Basque. First of all, it should be noted that nouns (176a from Ane Odria, p.c.) and participles (176b, c from Jon Ortiz de Urbina) allow coordination in Basque:

176.a. Ane eta Mikel

And and Mikel

b. Liburuak sal-tzen eta maita-tzen ditu

books sell-IMPF and love-IMPF Aux

S/he sells and loves books

c. Liburuak sal-du eta maita-tu ditu

books sell-PERF and love-PERF Aux

S/he has sold and loved books

The theory we are building up makes us believe that nouns and participles will show phrasal behavior even when they are followed by a bound morpheme. Ane Odria (p.c.) informs me that this expectation is met in Basque. It is possible to coordinate nouns even when they are followed by a case marker or bound postposition:

177. a. [Ane eta Mikel] -ek ogi -a -Ø jan dute  
Ane and Mikel-ERG bread-art-ABS eat.PRF Aux(have)  
Ane and Mikel have eaten bread.

b. Peru-Ø [Paris eta Madile]-n egon da  
 Peru-ABS Paris and Madrid-LOC stay-PRF Aux(be)  
 Peru has been to Paris and Madrid.

c. Korrikalari-ak-Ø [Donostia eta Bilbo]-tik etorri dira  
 Runners-art-ABS Donostia and Bilbo -ABL come-PRF Aux(be)  
 The runners have come from Donostia and Bilbo.

In Basque, the determiner marker is a bound morpheme. It is also possible to coordinate nouns stranding the article suffix:

178. Mikel-ek [ baloi eta panpin]-a -rekin jolastu du  
 Mikel-ERG ball and doll -DET -INST play-PERF Aux(have)  
 Mikel have played with the ball and the doll.

In Basque, future tense is expressed by adding the delimitative case *-ko* to the perfective participle as in:

179. Mintza-tu -ko naiz.  
 speak-PERF-DEL PRE.1SG

“I shall speak”

(from Haase, 2007)

Participles can also be coordinated. In such a scenario, the delimitative case marker is shared between the two conjuncts (Jon Ortiz de Urbina, p.c.):

180. Liburuak [sal-du eta maita-tu] -ko ditu  
 books sell-PERF and love-PERF-DEL Aux  
 S/he will sell and love books

The data presented in this section shows that nouns and participles in Basque show phrasal behavior both when they are bare and when are followed by bound morphemes. This is in conformity with the claims of this thesis in the sense that it shows that nouns and participles in Basque are always in a specifier position in Mirror Theoretic syntax.

#### 6.5.2. Noun Incorporation in Basque

The status of bare objects in the context of noun incorporation in the Basque language is explicitly discussed in Oyharçabal (2007). An example of a noun incorporation structure in Basque would be this (from Oyharçabal, 2007 p.794):

181. Lo egin dut  
 sleep make.PERF AUX  
 “I slept. “

In a noun incorporation analysis of bare objects in Basque, it is argued that the noun *lo* ‘sleep’ is actually incorporated in the verb *egin* ‘make-PERF’ via head-movement.

Oyharçabal (2007) notes that the earlier analysis of Basque light verb constructions as cases of noun-incorporation is faced with several empirical problems. For instance, light verbs can be separated from their “incorporated” nouns in questions:

182. Non [egin duzu]<sub>i</sub> lo t<sub>i</sub> ?

where make.PERF AUX sleep

“Where did you sleep?”

In the example (182), the complex *egin duzu*, which includes the main verb and the auxiliary, is fronted leaving the “incorporated” noun behind. This is something unexpected in head-movement analysis as the noun and the verb should behave as a unit after incorporation.

Also, light verbs can also undergo ellipsis unlike what we would expect in the case of real incorporation (Oyharçabal, 2007 p.793):

183. Lan egin dut, ez lo

work make.PERF AUX NEG sleep

“I worked, not slept (I made work, not sleep)”

In such structures, it seems that the verbal complex *egin dut* is deleted in the second conjunct. This is not what would be expected in a head-movement analysis of noun incorporation. The N-V complex does not behave as a unit.

Lastly, it is possible to coordinate “incorporated” nouns:

184. Ele eta lan egin dut

conversation and work do.PERF Aux

“I chatted and worked”

(Oyharçabal, 2007 p.795)

This implies that nouns still show phrasal behavior in the context of noun incorporation. Therefore, a head-movement analysis of noun incorporation cannot be the right analysis for such constructions.

Oyharçabal does not rule out the possibility of an incorporation analysis for certain Basque dialects. I will tentatively assume that those dialects also do not employ noun-incorporation.

## 6.6. English

### 6.6.1. Non-Verbal Items in English

In this section, I will be concerned with nouns, participles and the inflectional items that appear on nouns in English.

In English, it is possible to coordinate nouns (185a) and when there is a determiner outside the coordinated structure, its semantics is shared among the nouns (186b):

185. a. Jack and John

b. my [friend] and [colleague]<sup>33</sup>

It is also possible to coordinate present, perfect and passive participles in English.

---

<sup>33</sup> As noted in Heycock and Zamparelli (2005 p. 204), this construction may only mean that my friend is also my colleague. However, Heycock and Zamparelli note that the coordinated items may also have a split reading as in ‘This [man and woman] are in love’, where the man and the woman are not, of course, the same person.

For an analysis of such possibilities, see Heycock and Zamparelli (2005).

186. a. She was crying and smiling at the same time.  
b. I have [bought] and [sold] many houses over the years.  
c. I had [bought many houses] and [sold them] before I was twenty.<sup>34</sup>  
d. They were tortured and killed.

Nouns can be coordinated in English even when they are followed by the possessive marker –s.

187. [John and Jack]’s money

However, nouns preceding the English the plural marker cannot be coordinated.

188. a. \*A great number of [cat and dog]s<sup>35</sup>  
b. \*We will need some [table and chair]s

Given that in the theory being developed here nouns are expected to always show phrasal behavior, the ungrammaticality of these sentences is a problem for the current theory. I do not have a proposal to avoid this problem.

All in all, nouns and participles usually show phrasal behavior in English. One exception for nouns is the case where they are followed by a plural marker.

---

<sup>34</sup> I do not have an account of how the difference between the size of coordinated items in the sentences (186b) and (186c) should be expressed. In X-bar Theory, this could be done by the assumption that in (186b) it is the complex V-Asp heads that are coordinated while in the sentence (186c), it is the whole AspPs that are coordinated. The theory being developed here does not give me a way of expressing this distinction by making reference to different projection levels as I assume (following Brody, 2003) that there is no projection level in the first place. The question of how to express such differences remain as a topic for future research. Many thanks to Martina Gracanin-Yüksek (p.c.) for pointing this out to me.

<sup>35</sup> Bradley Larson (p.c.) informs me that the only interpretation that is possible for a sentence like “we saw a lot of cat and dogs running around” is the strange situation where there were a lot of hybrid cat/dog animals running around. How this interpretation is possible is an interesting question.

### 6.6.2. Noun Incorporation in English

Baker (1988 p. 78) argues that the English language does not have noun incorporation and cases like “money-loser” or “tobacco-buying” which show similarity to noun-incorporation structures are actually lexical compounding. They differ from real cases of incorporation because they are necessarily deverbal as the resulting form cannot be used as the verbal root (with few exceptions). Their being lexical does not support or refute the claims developed in this thesis.

### 6.7. Modelling the New Lexicon<sup>36</sup>

In this section, I would like to propose a theory of lexical features that will determine the syntactic position that a lexical object will occupy in Mirror Theoretic syntax of Brody. This will enable us to formalize the conclusions reached in this chapter and previous chapters.

We have seen that adopting an antilexicalist reading of Brody’s Mirror Theory, the suffixal status of a functional morpheme could be understood as the consequence of occupying a unique syntactic position. In the hypothetical tree below, all the (circled) objects that select for a complement will be interpreted as suffixes at Spell-Out:

---

<sup>36</sup> It is thanks to Martina Gracanin-Yüksek (p.c.) that I realized that I needed a theory of lexical features to be able to express why the objects behave the way they do. I owe the presence of this section, but not its problems, to her.

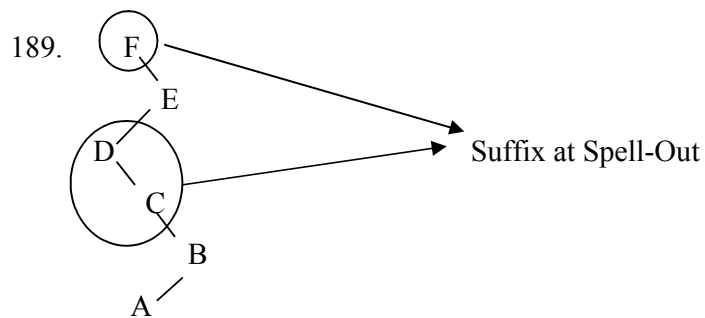

We have also seen that verbal items cannot appear in a specifier position, which is why, I argued, V-X holds. Verbal items always occupy a complement position.<sup>37</sup>

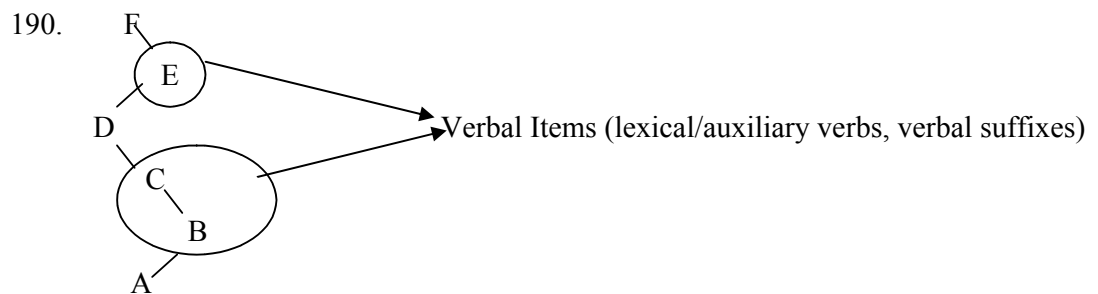

Lastly, I have argued that non-verbal objects (at least the two of them that this thesis is concerned with, namely nouns and non-verbal suffixes) cannot occupy the complement position that verbal items obligatorily occupy. Therefore, non-verbal items are always in specifier positions.

---

<sup>37</sup> See Uygun (2009) for a syntactic approach to verbal items in Turkish. See Baker (2003) and Kayne (2011) for other syntactic approaches to categories. It is a task of future research to compare the proposal made in this thesis with the proposals in these works.

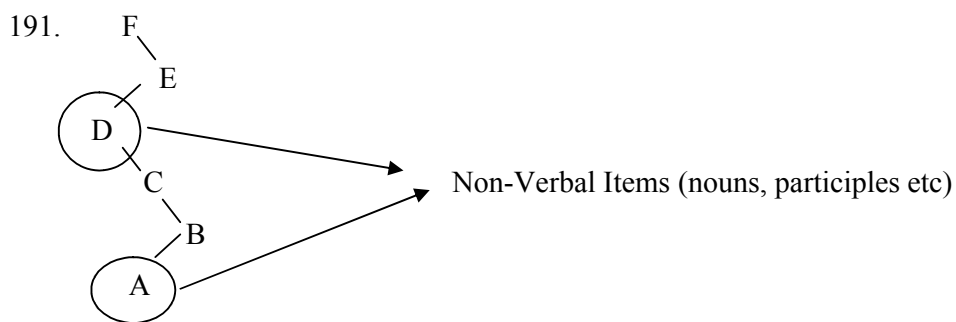

In the all the cases we have considered, we observed that a verbal root occupies the lowest position in a complementation line. Although it is an open question, I will assume that verbal items also differ from each other in the position they occupy as in:<sup>38</sup>

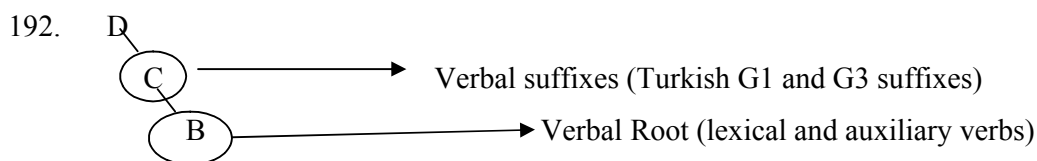

In the previous sections, I have used certain tests that, I claimed, indicate the syntactic position that a lexical object occupies. The question that I would like to address in this section is *why* a lexical object occupies the position it does. I would like to suggest that the configuration that a lexical object appears in is determined by selectional requirements in the lexicon and that certain taxonomic artefacts (such as verbs, verbal suffixes, non-verbal items and non-verbal suffixes) that are used to describe language actually correspond to unique structural positions.

<sup>38</sup> One problem for this claim would be V + V compounds. If the object that is immediately higher than verb can be a (lexical or auxiliary) verb, then we cannot define being a verb as occupying the lowest position in the complementation line. In order to avoid this conclusion, it must be true that in all cases of V + V compounds, the first verb is actually headed by a non-verbal suffix (null or overt). This is true in Japanese as the first conjunct in Japanese is headed by an infinitival marker (repeated from (80a).

- i. but-i hazime-ru  
hit-INF start-NONPAST  
“start hitting”

Whether it is also true cross-linguistically is an open question.

I will propose that lexical items differ with respect to features, which I call C and D features, that determine whether they will take a complement and/or will be taken as one.

It should be noted that I will not propose a full-fledged theory of lexicon. Rather, I will try to indicate the minimum configuration-related information that is needed to characterize the lexical objects that this thesis is concerned with.

Here is my proposal:

193. Selection

A selects B if A is immediately higher than B

and A is immediately higher than B if there is no X such that A is higher than X

and X is higher than B.

We need a feature to make sure that certain objects will obligatorily occupy a complement position. I will take this feature to be the feature C.

194. The feature C

A lexical object occupies a complement position if and only if it has the feature C.

We also need a feature to make sure that some objects will select for the objects that have the feature C. I will take this feature to be the feature D.

195. The feature D

A lexical object has the feature D if and only if it selects for a lexical an object with the feature C.

To see the consequences of the presence and absence of these features on the lexical items, let us assume that X, Y, Z and T are lexical items that differ in having one or both of these features or not.

Let X, Y, Z and T be lexical objects

Let X have only the feature C

Let Y have only the feature D

Let Z have both the feature C and the feature D

Let T have neither the feature C nor the feature D

Therefore, X is a lexical object that occupies a complement position as it has the feature C and that cannot select for a complement as it does not have the feature D. X corresponds to the verbal root. This can be a lexical verb or an auxiliary verb.

Y is a lexical object that cannot occupy a complement position as it lacks the feature C and that selects for a complement as it has the feature D. Y corresponds to a non-verbal suffix, i.e. to a suffix that selects for a verbal item but is itself not verbal. Turkish G2 suffixes, Hindi, English and Basque participles and Japanese infinitival suffix can be given as examples for such an object.

Z is a lexical object that occupies a complement position as it has the feature C and that selects for a complement as it also has the feature D. Z corresponds to a verbal suffix. Turkish verbal negation morpheme or verbal past tense morpheme can be given as examples.

T is a lexical object that cannot occupy a complement position and that cannot select a complement position. T corresponds to an item that is non-verbal and that is a non-suffix. Nouns, case markers (as phrasal affixes), adpositions, adjectives can be given as

examples. How to derive finer distinctions between such objects is a topic for future research.

This basically eliminates the need for [+/- suffix] and [+/- verbal] features not only from the lexicon but also from grammar in general. The primitives needed to address such objects are the features C and D which determine the syntactic position an object occupies.

What is the advantage of replacing [+ verbal] with the feature C and [+suffix] with the feature D?

In Chapter IV, I argued that a verbal item cannot show phrasal behavior. It should be noted that nothing intrinsic to being a verbal item explains this. To the extent that being in a complement position defines what it is to be a verbal item, we understand why verbal items cannot show phrasal behavior. It could not be otherwise since only an object that occupies a specifier position can show phrasal behavior. Also, nothing in the feature [+ suffix] tells us why (i) it has to appear on a verbal item and (ii) it cannot appear on non-verbal items. Defining suffix as the object that takes a verbal item as its complement tells us why these two observations are true. Needless to say, it is an empirical question whether the claims made in this thesis can be extended to other languages of the world.<sup>39</sup>

Let me bring this section to an end by reminding the reader of the predictions of the theory. I will use the sign ( - ) in order to express affixation that is produced under Mirror (i.e. suffixation) and the sign ( = ) to express phrasal affixation and cliticization. The

---

<sup>39</sup> Problematic cases include Hungarian nominal inflection, which usually does not allow suspended affixation (the examples are from Kiss, 2004 p. 134-135)

- i.        \*a ház    és    a    garázs -nál  
             the house and the    garage-ADESSIVE  
             Int: “at the house and the garage”

However, rarely a nominal inflectional element can be shared:

- ii.        feleség és anya    -ként  
             wife    and mother-ESSIVE  
             “as mother and wife”

Another problematic language is Finnish. I hope that in the future I will be able to analyze these cases closely and see if an analysis of noun inflection as phrasal affixation can be given.

absence of these signs implies that the object in question is free. Let us assume that X is the lexical item that is immediately higher than a verbal item, then

196.a. V-X (suffixation)

Ex: walk-ed

- b. \*V=X (phrasal affixation or cliticization)
- c. \*X=V (prefixation)
- d. \*V X (free morpheme following the verbal item)
- e. \*X V (free morpheme preceding the verbal item)

This indicates that the morpheme immediately above the verbal item cannot be a free morpheme, a prefix or a phrasal affix. Any time we see a morpheme of this sort, it should be possible to show that its complement is not verbal; otherwise, it is a counterexample.

Let us assume that Y is the lexical item that is immediately higher than a non-verbal (nV) item, then:

197. a. \*nV-Y (suffixation)

b. nV=Y (phrasal affixation)

(Repeated from (143) (Kabak, 2007))

Turkish

ev ve dükkan=lar=da

house and shop=PL=LOC

“in houses and shops”

c. Y=nV (prefixation)

(from Collins, 1962 as qtd in Dryer, 2005 p.210)

Tonga (Bantu; Zambia)

wakaboola a=Joni

he.came with=John

“He came along with John.”

d. nV Y (free morpheme)

(Repeated from 11. c.)

Turkish

öğrenci değil

student nV.NEG

“he is not a student”

e. Y nV (free morpheme, the articles in English)

a book

the book

This indicates that the morpheme immediately above a non-verbal item can be anything but a suffix.

It should be noted that in this thesis I have not discussed prefixes. It is only a hope, for the time being, that they can be shown to occupy a specifier position when they are syntactic objects.

Also, Brody (2003), following Kayne (1994), argues that specifiers always precede the objects that they are specifier of. Given that I argue that non-verbal items are always in the specifier position of the morpheme immediately higher than them, this predicts that non-verbal items will always precede the objects that they are specifier of. This is an

unfortunate conclusion since we know that in English, for example, articles precede the noun. I do not have a proposal as to what changes are needed in the theory to be able to express these facts. I leave it for future research. It should also be noted that the current theory correctly predicts that English articles are not suffixal objects.

All in all, in this section, I developed a theory of lexical features that formalized the conclusions reached in this chapter and in the previous chapters.

## CHAPTER VII: CONCLUSION

### 7.1. The Summary of the Claims

In this thesis, I argued that the suffixal and verbal status of a morpheme can be derived from the syntactic position that it occupies using the Mirror Theoretic syntax of Brody (2003).

I showed that the suffixal status of a morpheme is predictable from its syntactic environment. More specifically, I argued that in Turkish, Basque, Japanese, Hindi and English, the morpheme that is immediately above a verbal item has to be a suffix on this verbal item (V-X). Adopting an antilexicalist version of Brody's Mirror Theory, I argued that the suffixhood of the morpheme syntactically right above a verbal item is a consequence of the fact that verbal items always occupy a complement position in Brody's Mirror Theoretic syntax and the morphemes that show suffixal character select verbal items as their complement. The evidence for the claim that verbal items always occupy the complement position comes from the observation that verbal items cannot move to the specifier of topic, focus or focus-related morphemes and that verbal items cannot be coordinated. I argued that many cases that look like verbal item fronting or verbal item coordination are better analyzed as movement or coordination of infinitival elements.

I argued that not only is it the case that a verbal item must occupy a complement position, it is also the case that non-verbal items (in the thesis, nouns and participles) cannot occupy this position. They have to occupy a specifier position. I argued that this is why non-verbal items always show phrasal behavior. The evidence for the claim that non-verbal items always show phrasal behavior comes from the observation that non-verbal items can be coordinated both when they are bare and when they are followed by a bound

morpheme (creating the effect of so-called “suspended affixation”). I also presented evidence from the linguistic literature indicating that head movement analysis of noun incorporation in Turkish, Basque, Hindi and Japanese is faced with empirical challenges. Therefore, in these constructions, too, nouns cannot be argued to show head-like behavior.

I lastly developed a theory of lexical features where lexical features determine the position that a lexical object can occupy. This makes it possible to show that the objects called a verbal item, a verbal suffix, a non-verbal item and a non-verbal suffix correspond to designated positions in Mirror Theoretic syntax.

## 7.2. Questions for Future Research

The V-X constraint states that the morpheme immediately above a verbal item is a suffix on this verbal item. This is a very strong prediction about what a possible language should be like. Therefore, more cross-linguistic evidence is needed to verify that this constraint is correct for languages that have not been discussed in this thesis. Especially interesting is the case of morphologically poor languages like Chinese. It may be necessary that we need to postulate some zero morphemes for such languages. I believe that, for the V-X constraint to be meaningful, there must be independent evidence showing that the zero morphemes that are postulated for such languages are really there.

Also, my criticism of X-bar Theory is not conclusive. It is perfectly possible that there are other ways of deriving suffixhood from syntactic configuration in X-bar Theory that I failed to consider here. I believe that in later studies, this question must be addressed in further detail.

In the theory developed in this thesis, linguistic items have been divided into two big groups: suffixal objects and non-suffixal objects (leaving aside the issue of verbalness).

Among non-suffixal objects are phrasal affixes, clitics, prefixes and free morphemes.

Whether finer distinctions among non-suffixal objects can be derived from syntactic facts is again a topic for further research.

My claim that the morpheme immediately above a non-verbal object cannot be a suffix is faced with empirical challenges. One problem that I was confronted with has been to show that English plural morpheme is actually a phrasal affix. However, I failed in this. I am aware that it is difficult to argue that nominal inflection in Hungarian or Finnish is phrasal given that suspended affixation is usually not a possibility in these languages. Therefore, it may be necessary to come up with new tests that can differentiate phrasal and non-phrasal objects that will work for such languages. Of course, it may also be the case that the predictions of the theory developed in this thesis are just not true. I leave this issue for future research.

I believe that the question of how many of the taxonomic artefacts that we use to describe languages can be derived from syntactic facts is a very interesting one. This is why, I would like to end this thesis with expressing my hope that this question will be asked more frequently and directly in future works.

## REFERENCES

- Adger, D, Harbour, D and Watkins, L (2009). *Mirrors and Microparameters: Phrase Structure beyond Free Word Order*. Cambridge: Cambridge University Press
- Arregi, K. (2000). *Tense in Basque*. Ms. The University of Chicago
- Arslan Kechriotis, Z. C. (2006). *Case as an uninterpretable feature*. Ph.D. dissertation, Boğaziçi University, İstanbul.
- Aygen-Tosun, G. (1998). *The SPLIT INFL Hypothesis in Turkish*. M.A. thesis, Boğaziçi University, İstanbul.
- Baker, M. (1985). The Mirror Principle and Morphosyntactic Explanation. *Linguistic Inquiry*, 16, 373-415.
- Baker, M. (1988). *Incorporation: A theory of grammatical function changing*. Chicago: University of Chicago Press.
- Baker, M. (2003). *Lexical categories: verbs, nouns and adjectives*. Cambridge: Cambridge University Press.
- Baker, M. (2005) *On Gerunds and the Theory of Categories*. Ms, Rutgers University.
- Baker, M., Johnson, K. and Roberts, I. (1989). Passive Arguments Raised. *Linguistic Inquiry*, 20.2, 219-252.
- Bhatt, R. (2005). Long Distance Agreement in Hindi-Urdu. *Natural Language and Linguistic Theory* ,23, 757-807.
- Brody, M. (2003). *Towards An Elegant Syntax*. London: Routledge.
- Butt, M., and T. H. King. (1999). *The Status of Case*. Ms. University of Stuttgart and Stanford University.
- Butt, M. and G. Ramchand. (2005). Complex Aspectual Structure in Hindi/Urdu. In N. Ertischik-Shir and T. Rapoport (eds.), *The Syntax of Aspect*. Oxford: Oxford University Press.
- Chomsky, N. (1970). Remarks on Nominalization. In: R. Jacobs and P. Rosenbaum (eds.), *Readings in English Transformational Grammar* (p. 184 – 221). Waltham, Mass: Ginn.
- Chomsky, N. (1995). *The Minimalist Program*. Cambridge, Mass.: MIT Press.
- Chomsky, N. (2001). Derivation by phase. In M. Kenstowicz (ed.) *Ken Hale: A Life in Language*. Cambridge, Mass.: MIT Press

- Cinque, G. (1999). *Adverbs and Functional Heads*. Oxford: Oxford University Press.
- Dayal, V. (2011). Hindi pseudo-incorporation. *Natural Language & Linguistic Theory* 29.1, 123-167.
- Dryer, M. S. (2005). Position of Case Affixes. In M. Haspelmath, M. S. Dryer, D. Gil, and B. Comrie (Eds.) *The World Atlas of Language Structures* Oxford: Oxford University Press.
- Enç, M. (2004). Functional categories in Turkish. In A. Csirmaz, Y. Lee, & M. A. Walter (eds.), *Proceedings of the Workshop on Altaic Formal Linguistics I. MIT Working Papers in Linguistics*, 46, 208 – 226.
- Freeze, R. (1992) Existentials and Other Locatives, *Language*, 68, 553-595.
- Fukushima, K. (1999). Bound morphemes, coordination and bracketing paradox. *Journal of Linguistics*, 35, 297-320.
- Göksel, A. (1993). Levels of Representation and Argument Structure in Turkish. PhD Dissertation, University of London.
- Göksel, A. (2001). The auxiliary verb at the morphology-syntax interface. In E. Erguvanlı-Taylan (ed.) *The Verb in Turkish*, Amsterdam: John Benjamins.
- Gracanin-Yüksek, M. and İşsever, S. (2011). Movement of Bare Objects in Turkish. *Dilbilim Araştırmaları*, 2011.1, 33-49.
- Haase, M. (2007). *Tense and Aspect in Basque*. Ms. Universitaet Osnabrueck. Retrieved October, 10, 2011 from <http://www.buber.net/Basque/Euskara/tense.html>
- Haddican, B. (2007). On Egin: Do-support and VP Focus in Central and Western Basque. *Natural Language & Linguistic Theory*, 25, 735-764.
- Halle, M. and Marantz, A. (1993). Distributed Morphology and the pieces of inflection. In K. Hale and S. J. Keyser (Eds), *The View from Building 20*, (p. 111-176). Cambridge MA: MIT Press.
- Harley, H. (2004). Merge, conflation, and head movement: the first sister principle revisited. In K. Moulton and M. Wolf (Eds.), *Proceedings of NELS 34*, (p. 239-254). Amherst, MA: UMass, GLSA
- Heycock, C. and Zamparelli, R. (2005). Friends and Colleagues: Plurality, Coordination, and the Structure of DP. *Natural language semantics*, 17.3, 201-270.
- Holmberg, A. (2000). Deriving OV Order in Finnish. In P. Svenonius (ed.). *The Derivation of VO and OV* (p. 123 – 152). Oxford/New York: Oxford University Press.
- Hornstein, N. Martins, A. M. and Nunes, J. (2008). Perception and Causative Structures in English and European Portuguese. *Syntax*, 11.2, 198 – 222.

- Jackendoff, R. (1977) *X-Bar Syntax: A Study of Phrase Structure*. Cambridge, Mass: MIT Press
- Julien, M. (2002). *Syntactic Heads and Word Formation*. Oxford University Press. New York
- Kabak, B. (2007). Turkish suspended affixation. *Linguistics* 45.2 . 311- 347.
- Kachru, Y. (2006) *Hindi*. Amsterdam: John Benjamins
- Kamali, B. (2011). The question particle in Turkish: Consequences for the interfaces. In *Online complement to Proceedings of WCCFL 28. University of Southern California*.
- Kayne, R. (1993). Towards a modular theory of auxiliary selection. *Studia Linguistica*, 47.1, 3–31.
- Kayne, R. (1994). *The Antisymmetry of Syntax*. Cambridge, Mass.: MIT Press.
- Kayne, R. (1998). Overt vs. covert movement. *Syntax*, 1, 128–191.
- Kayne, R. (2011). Antisymmetry and the Lexicon in A.M. Di Sciullo, and C. Boeckx (Eds.), *The Bilingualistic Enterprise: New Perspectives on the Evolution and Nature of the Human Language Faculty* (p. 329 – 353), Oxford University Press, Oxford.
- Kato, T. (2006) *The CSC as an LF condition: Evidence from Neg-raising in Japanese*. Abstract submitted to Penn Linguistic Colloquium. Retrieved 25 April, 2012 from <http://www.ling.upenn.edu/Events/PLC/plc30/abstracts/18.pdf>
- Kelepir, M. (2001). *Topics in Turkish syntax: clausal structure and scope*. PhD Dissertation, MIT.
- Kelepir, M. (2012). *The presence/absence of Tense and Evidentiality in nominalized complement clauses: some insights from three Turkic languages*. Ms. Boğaziçi University.
- Kimura, N. (2006). *Predicate Fronting, (Non)-Agentive Subject Positions, and Cyclic Linearization in Japanese*. Ms. The University of Washington
- Kiss, K. (2002). *The Syntax of Hungarian*. Cambridge: Cambridge University Press.
- Knecht, L. E. (1986). *Subject and Object in Turkish*. PhD Dissertation, MIT.
- Koopman, H. (2005). Korean (and Japanese) Morphology from a Syntactic Perspective *Linguistic Inquiry*, 36, 601-63.
- Koopman, H. (2006). Agreement: in defense of the Spec head configuration. In Cedric Boeckx (Ed.) *Agreement systems* (p. 159-199). Amsterdam: John Benjamins.

- Kornfilt, J. (1996). On some copular clitics in Turkish. *ZAS Papers in Linguistics*, 6, 96 – 114.
- Kornfilt, J. (2003). Scrambling, subscrambling and case in Turkish. In S. Karimi (ed.) *Word Order and Scrambling* (p. 125 – 155), Malden, MA: Blackwell
- Kotani, Y. (2002). *Disambiguation of Coordinate Expressions in Japanese by Extracting Mutual Case Relation*, Ms. Tokyo U of Agriculture and Technology.
- Kumar, R. (2006). *Negation and licensing of negative polarity items in Hindi syntax*. New York/London: Routledge.
- Kural, M. (1993). V-to(-I-to)-C in Turkish. *UCLA Occasional Papers in Linguistics*, 11, 17 – 53.
- Kural, M. (1997). Postverbal Constituents in Turkish and the Linear Correspondence Axiom. *Linguistic Inquiry* 28.3
- Kuroda, S-Y (1965). *Generative grammatical studies in the Japanese language*. Ph.D. Dissertation. MIT.
- Lewis, G. L. (1986) (revised edition of 1967). *Turkish grammar*. Oxford: Oxford University Press,
- Lieber, R. (1980). *On the Organization of the Lexicon*. Doctoral dissertation, MIT.
- Malouf, R. (2000). *Mixed Categories in the Hierarchical Lexicon*. Stanford, Calif.: CSLI publications.
- Manfredi, V. (1993). Verb focus in the typology of Kwa/Kru and Haitian. In F. Byrne & D. Winford (Eds.), *Focus and grammatical relations in Creole languages* (pp. 3-51). Benjamins, Amsterdam/ Philadelphia.
- Matushansky, O. (2006). Head-Movement in Linguistic Theory. *Linguistic Inquiry*, 37.1, 69–109.
- Miyagawa, S. (2001). EPP, Scrambling and wh-in situ. In M. Kenstowics (ed.) *Ken Hale: A Life in Language* (p. 293- 338), Cambridge, Mass.: MIT Press.
- Namai, K. (2002). The Word Status of Japanese Adjectives. *Linguistic Inquiry*, 33.2, 340 – 349.
- Nunes, J. (1995). The diachronic distribution of bare and prepositional infinitives in English. In H. Andersen (Ed.). *Historical linguistics 1993: Selected papers from the 11th International Conference on Historical Linguistics* (p. 357–369). Amsterdam: John Benjamins.
- Ouhalla, J. (1991). *Functional categories and parametric variation*. London: Routledge.

- Orgun, C. (1996). Suspended affixation: a new look at the phonology-morphology interface. In U. Kleinhenz (Ed.) *Interfaces in Phonology*, (p. 251–261). Berlin: Akademie Verlag.
- Oyharçabal, B. (2007). Basque light verb constructions. In J. A. Lakarra and J. I. Hualde (Eds.) *Studies in Basque and Historical Linguistics*, (p. 787–806). Bilbao: Diputacion Foral de Gipuzkoa - Gipuzkoako Foru Aldundia & Universidad de Pais Vasco - Euskal Herriko Unibertsitatea
- Özsoy, A. S. (2001). On ‘small’ clauses, other ‘bare’ verbal complements and feature checking in Turkish. In E. Erguvanlı-Taylan (ed.), *The Verb in Turkish* (p. 213 – 237), Amsterdam: John Benjamins.
- Öztürk, B. (1999). *Turkish as a non-pro-drop language*. MA Thesis. Boğaziçi University.
- Öztürk, B. (2005). *Case, Referentiality and Phrase Structure*. Amsterdam: John Benjamins Publishing Company.
- Öztürk, B. (2009). Incorporating agents. *Lingua* 119, 334-358.
- Öztürk, B. (in press) Postverbal constituents in SOV languages. *Theoretical Approaches to Disharmonic Word Orders*, M. Sheehan and M. T. Biberauer (eds.), Oxford University Press.
- Pollock, J-Y. (1989). Verb Movement, Universal Grammar and the structure of IP. *Linguistic Inquiry*, 20, 365 – 424.
- Poser, W. (1989). Japanese Peripherastic Verbs and Noun Incorporation. To appear in *Natural Language and Linguistic Theory*.
- Pullum, G. (1991). English nominal gerund phrases as noun phrases with verb phrase heads. *Linguistics*, 29, 763-799.
- Raposo, E. P. (1987). Romance infinitival clauses and case theory. In C. Neidle and R. A. N. Cedeno (Eds.), *Studies in Romance languages*, (p. 237–249). Dordrecht: Foris.
- Rizzi, L. (1997). On the fine structure of the left-periphery. In L. Haegeman (Ed.) *Elements of Grammar*. (p. 281-337). Dordrecht: Kluwer.
- Ross, J. R. (1967). *Constraints on Variables in Syntax*. Ph.D. dissertation, MIT.
- Sells, P. (1995). Korean and Japanese morphology from a lexicalist perspective. *Linguistic Inquiry*, 26, 277 – 326.
- Sezer, E. (2001). Finite Inflection in Turkish. In E. Erguvanlı-Taylan (ed.), *The Verb in Turkish* (p. 1 – 45), Amsterdam: John Benjamins.

- Suzuki, T. (1989). A syntactic analysis of an honorific construction o ...-ni naru. In J. Fee & K. Hunt (Eds.), *The proceedings of the 8th West Coast conference on formal linguistics* (pp. 373–383). Stanford Linguistics Association, CSLI, Stanford University.
- Svenonius, P. (1994). C-selection as feature checking. *Studia Linguistica*, 48, 133–155.
- Taylan, E. E. (1984). *The Function of Word Order in Turkish Grammar*. Berkeley: University of California Press.
- Tsujimura, N. (2007). *An introduction to Japanese linguistics (2<sup>nd</sup> ed.)*. Oxford: Blackwell
- Ulutaş, S. (2006) *Verb Movement and Feature Percolation: Evidence from Turkish Relative Clauses*. MA Thesis. Bogazici University.
- Uygun, D. (2009). *A split model for category specification: Lexical categories in Turkish*. PhD Dissertation. Boğaziçi University.
- Vance, J. T. (1993). Are Japanese Particles Clitics? *The Journal of the Association of Teachers of Japanese*, 27.1, 3-33.
- Vermeulen, R. (2006). Case and coordination in Japanese. *WCCFL* 25, 417-425
- Yavaş, F. (1980). *On the Meaning of Tense and Aspect Markers in Turkish*. PhD dissertation, University of Kansas.
- Yu, A. C. and J. C. Good. (2000). Morphosyntax of two Turkish subject pronominal paradigms. *Proceedings of NELS* 30, 759-773.
- Zwart, J-W. (2001). Syntactic and Phonological Verb Movement. *Syntax*, 4.1, 34-62.
- Zwart, J-W. (2002). The antisymmetry of Turkish. *Generative Grammar @ Geneva* 3, 23-36.