

**DESIGN OF A VIRTUAL ENVIRONMENT FOR
DISCRIMINATION TASKS TO DETERMINE THE
PSYCHOMETRIC FUNCTION**

by

Taha Süleyman Hasekiöglu

B.S., in Biomedical Engineering, Rensselaer Polytechnic Institute, 2013

Submitted to the Institute of Biomedical Engineering
in partial fulfillment of the requirements
for the degree of
Master of Science
in
Biomedical Engineering

Boğaziçi University

2019

ACKNOWLEDGMENTS

I would first like to express my sincere gratitude to my thesis advisor Professor Burak Güçlü of the Institute of Biomedical Engineering at Bogazici University for his continuous support in my related research and for his immense patience and motivation.

I want to thank all my professors, the staff at the Institute of Biomedical Engineering at Boğaziçi University, and everyone at the Tactile Research Laboratory for all their support whenever I may need it. And many thanks to my dear friend from Mexico, Alejandro Vargas, whose contributions were invaluable.

Finally, I would like to thank my parents for all their support all my life and my brother, Yasin Hasekioğlu, for always being there in my times of need.

ACADEMIC ETHICS AND INTEGRITY STATEMENT

I, Taha Süleyman Hasekiöglu, hereby certify that I am aware of the Academic Ethics and Integrity Policy issued by the Council of Higher Education (YÖK) and I fully acknowledge all the consequences due to its violation by plagiarism or any other way.

Name :

Signature:

Date:

ABSTRACT

DESIGN OF A VIRTUAL ENVIRONMENT FOR DISCRIMINATION TASKS TO DETERMINE THE PSYCHOMETRIC FUNCTION

In this thesis, we used the Gazebo simulation software to develop a virtual environment for interactions of objects to perform psychophysical tasks to distinguish between objects at differing stiffnesses. The virtual environment is composed of a probing device, a cube, and a slider. The probing device is used to touch the cube which moves on the slider. The environment includes objects of different stiffnesses, and the user attempts to discriminate between these objects. To simulate the effect of deformation in the cube, we modeled the cube as a mass-spring-damper system, so the object generates a force proportional to the distance it is pushed by force generated from the probe contacting the cube. The virtual environment was tested by recording the step response of each cube with different k constants. The cube deformed according to the model. Six users were asked to perform psychophysical trials on the virtual environment for stiffness discrimination. Six identical cubes with different stiffnesses were used, where the stiffest cube was used as the reference. The subjects were asked to discriminate between each cube and the reference object. Then we plotted the psychometric curve and determined the discrimination threshold from the data produced. The experiment was done in three phases with twenty trials in each phase. In the first phase, the user would see the virtual environment and also listen to the auditory signal. In the second phase, the user was blindfolded and only received the audio signal. In the third phase, the auditory signal of the virtual environment was muted, and the user only received the visual signal, which was the distance the cube moved. The psychophysical trials show that the virtual environment can be used to determine the psychometric curve and discrimination threshold of the user's ability to discriminate between objects of different stiffnesses.

Keywords: Psychophysics, Psychometric Function, Virtual Environment, Stimulus, Discrimination Threshold.

ÖZET

AYIRT ETME DENEYLERİ İLE PSİKOMETRİK FONKSİYONUN BELİRLENMESİ İÇİN SANAL ORTAM TASARIMI

Bu tezde, farklı sertliklerde nesnelere arasında ayırım yapmak için psikofiziksel görevleri gerçekleştirmek üzere nesnelere etkileşimi için sanal bir ortam geliştirmek amacıyla Gazebo simülasyon yazılımını kullandık. Sanal ortam bir sondalama aygıtı, bir küp ve bir kaydırıcıdan oluşur. Sonda cihazı, kaydırıcıda hareket eden küpe dokunmak için kullanılır. Çevre, farklı sertlikte nesnelere içerir ve kullanıcı bu nesnelere arasında ayırım yapmaya çalışır. Küpteki deformasyonun etkisini taklit etmek için, küpü bir kütle yay sönümleyici sistemi olarak modelledik, böylece nesne, küp ile temas eden probdan üretilen kuvvet tarafından itilen mesafeye orantılı bir kuvvet oluşturur. Yayın k sabiti, her denemede farklı sertlik özelliklerine sahip “dokunma” nesnelere sahip algısını simüle etmek için manipüle edildi. Sanal ortam, her bir küpün adım yanıtını farklı k sabitleri ile kaydederek test edildi. Küp modele göre deforme oldu. Altı kullanıcıdan sertlik ayrımcılığı için sanal ortamda psikofiziksel denemeler yapmaları istendi. Dışında benzer olan ancak en sert küpün referans nesne olarak kullanıldığı farklı sertliklere sahip altı küp vardı. Deneklerden bu nesnelere ve referans nesne arasında ayırım yapmaları istendi ve biz psikometrik eğri çizdik ve üretilen verilerden ayrımcılık eşikini belirledik. Deney, her aşamada yirmi denemeyle üç aşamada yapıldı. İlk aşamada, kullanıcı sanal ortamı görür ve ayrıca işitsel sinyali dinlerdi. İkinci aşamada, kullanıcı gözü kapalı ve sadece ses sinyali aldı. Üçüncü aşamada, sanal ortamın işitsel sinyali susturuldu ve kullanıcı yalnızca küpün hareket ettiği mesafe olan görsel sinyali aldı. Bu, her geri bildirim türünün yanıtını karşılaştırmak için yapıldı. Psikofiziksel denemeler, sanal ortamın, kullanıcının görsel ve / veya sesli geri bildirimine dayalı farklı sertlikteki nesnelere arasında ayırım yapabilme yeteneğinin psikometrik eğrisi ve ayrımcılık eşikini belirlemek için kullanılabileceğini göstermektedir.

Anahtar Sözcükler: Psikofizik, Psikometrik fonksiyon, Sanal Ortam, Uyarıcı, Ayırt etme eşik.

TABLE OF CONTENTS

ACKNOWLEDGMENTS	iii
ACADEMIC ETHICS AND INTEGRITY STATEMENT	iv
ABSTRACT	v
ÖZET	vi
LIST OF FIGURES	viii
LIST OF TABLES	x
LIST OF SYMBOLS	xi
LIST OF ABBREVIATIONS	xii
1. INTRODUCTION and MOTIVATION	1
2. BACKGROUND and THEORY	2
2.1 Psychophysics and Psychometric Function	2
2.2 Simulation Environments	7
3. METHODS	10
3.1 The Virtual Environment	10
3.2 The Psychophysical Experiment	21
3.3 Participants	23
3.4 Data analysis and Curve fitting	23
4. RESULTS	25
4.1 Psychometric Curve for Audio and Visual Feedback	25
4.2 Psychometric Curves for Audio Feedback	32
4.3 Psychometric Curves for Visual Feedback	38
5. DISCUSSION	44
5.1 Comparison with other Stiffness Discrimination Environments	45
5.2 Limitations	46
5.3 Future Work	46
6. CONCLUSION	48
REFERENCES	49

LIST OF FIGURES

Figure 2.1	Representation of the Psychometric Function.	4
Figure 2.2	Description of the Method of Limits for Absolute Threshold [1].	5
Figure 2.3	Description of the Method of Constant Stimuli for Absolute Threshold [1].	6
Figure 2.4	Psychometric Function in 2-AFC Procedures [2].	7
Figure 2.5	Gazebo World Example.	9
Figure 3.1	The Virtual Environment on the Gazebo Simulator when it is started.	11
Figure 3.2	The Virtual Environment on the Gazebo Simulator when the probe is in contact with the cube.	12
Figure 3.3	Spring-Damper model of contact [3].	13
Figure 3.4	Free-Body Diagram of mass-spring-damper [4].	14
Figure 3.5	Step responses of a second-order system.	15
Figure 3.6	Architecture of the Virtual Environment.	16
Figure 3.7	Flow diagram of Virtual Environment Experiment.	17
Figure 3.8	Step Response to k_{ref} .	19
Figure 3.9	Step Response to k_1 .	19
Figure 3.10	Step Response to k_2 .	20
Figure 3.11	Step Response to k_3 .	20
Figure 3.12	Step Response to k_4 .	21
Figure 3.13	Step Response to k_5 .	21
Figure 3.14	Trial in the Virtual Environment.	22
Figure 4.1	Psychometric Function for User 1 with Visual and Audio Feedback.	26
Figure 4.2	Psychometric Function for User 2 with Visual and Audio Feedback.	27
Figure 4.3	Psychometric Function for User 3 with Visual and Audio Feedback.	28
Figure 4.4	Psychometric Function for User 4 with Visual and Audio Feedback.	29
Figure 4.5	Psychometric Function for User 5 with Visual and Audio Feedback.	30
Figure 4.6	Psychometric Function for User 6 with Visual and Audio Feedback.	31
Figure 4.7	Psychometric Function for User 1 with Audio Feedback.	32

Figure 4.8	Psychometric Function for User 2 with Audio Feedback.	33
Figure 4.9	Psychometric Function for User 3 with Audio Feedback.	34
Figure 4.10	Psychometric Function for User 4 with Audio Feedback.	35
Figure 4.11	Psychometric Function for User 5 with Audio Feedback.	36
Figure 4.12	Psychometric Function for User 6 with Audio Feedback.	37
Figure 4.13	Psychometric Function for User 1 with Visual Feedback.	38
Figure 4.14	Psychometric Function for User 2 with Visual Feedback.	39
Figure 4.15	Psychometric Function for User 3 with Visual Feedback.	40
Figure 4.16	Psychometric Function for User 4 with Visual Feedback.	41
Figure 4.17	Psychometric Function for User 5 with Visual Feedback.	42
Figure 4.18	Psychometric Function for User 6 with Visual Feedback.	43
Figure 5.1	Depiction of virtual environment used in Argelaguet et al [5].	45
Figure 5.2	Depiction of virtual environment used in Argelaguet et al [5].	47

LIST OF TABLES

Table 3.1	k constants used in the virtual environment to model stiffness.	18
Table 3.2	Difference intervals of k (N/m) tested in the trial.	22
Table 4.1	Discrimination threshold of each experiment with visual and audio feedback.	31
Table 4.2	Discrimination threshold of each experiment with audio feedback.	37
Table 4.3	Discrimination threshold of each experiment with visual feedback.	43

LIST OF SYMBOLS

u_t	Weber's fraction
I	Stimulus intensity
S	Perceived sensation of the stimulus
F_k	Force from spring
k	Spring constant
F_b	Force from damper
b	Damping constant
m	mass
t	time
P_c	Probability of correct discrimination
ζ	Damping ratio

LIST OF ABBREVIATIONS

2-AFC	Two-alternative choice
JND	Just noticeable difference

1. INTRODUCTION and MOTIVATION

This aim of this thesis is to design a virtual environment to develop psychophysical experiments to distinguish between objects at differing stiffnesses. It is a proof of concept of a simple virtual environment designed to present subjects to objects at various stiffnesses and have them discriminate the objects based on audio and visual stimulus at intensities proportional to the rigidity of each object.

Researchers use such simulation environments in the design and training of neuroprosthetics. Recently neuroprosthetics is an emerging field which aims to close the feedback loop in myoelectric prosthesis by adding an interface into the brain and also haptic sensors on the hand. This approach has proven to be a difficult task. Robotics simulators can be of use in developing robotic hand models to understand how the prosthesis should work and also in training people to use neuroprosthetics with brain-computer interfaces [6].

Telemedicine is also an important point of application for such a virtual environment. A virtual environment can be used in telemedicine with robotic-assisted surgery to train physicians and optimize the robotics for touching and gripping. In recent years, there has been staggering progress in the development of robotic systems for telemedicine such as the da Vinci Surgical System and others. As such systems become more widely used, intuitive virtual environments for physicians to train and operate in will become a necessity [7].

2. BACKGROUND and THEORY

2.1 Psychophysics and Psychometric Function

A response threshold is used to measure the performance of a psychophysical experiment. This response threshold is a given level of how often the subject can discriminate different stimulus intensities when compared to a fixed stimulus. The psychometric function provides such a response threshold [8], [9].

The psychometric function is referred to as the relationship between a physical stimulus and the subject's force-choice response to the stimulus and is used to model detection and discrimination tasks [10]. With psychometric functions, the relationship between the perceived performance and physical properties of the stimulus can be quantified. In other words, when the experimenter presents the subject with a stimulus where the strength of the stimulus is varying over a range in a rating task with two choices a plot of the detection probability as a function of the stimulus's intensity or difference in the stimulus's intensity is called the psychometric function. The discrimination probability is how often the subject successfully discriminates between the given stimuli [11]. In the case of this thesis, we used the Two-alternative force-choice (2-AFC) task.

The field of psychophysics studies the relations between physical stimuli and the subject's perceptions of the stimuli [12]. Gustav Theodor Fechner coined the term and forming the methodology of psychophysics in 1860 [13]. He worked closely with Heinrich Weber, who studied the sense of touch and light to determine the minimum discernible difference in intensity of stimuli or the just noticeable difference (JND) [14].

Weber and Fechner's research came to two significant results. The first of these known as Weber's law is that the just noticeable difference of a given physical stimulus

is a constant ratio of the reference stimuli. The law is described by

$$u_t = \frac{\Delta I}{I} \quad (2.1)$$

where I is the magnitude of the stimulus intensity and the change in I is the difference threshold required to produce a JND in sensation and u_t is a constant known as Weber's Fraction [15].

The second, known as Fechner's law, is that sensitivity to a stimuli changes based on the subject and the sense being affected and that the relationship between a stimulus (particularly loudness and brightness) and how it is perceived is logarithmic:

$$S = c \log I \quad (2.2)$$

where S is the perceived sensation of the stimulus, I is the magnitude of the stimulus, and c is a sense specific constant that should be determined based on the stimuli [15]. However, these laws have been shown to fail at low and higher intensities.

As mentioned above, researchers measure psychophysical tests through a response threshold. Generally, this is the absolute threshold or the difference threshold used in detection and discrimination tests, respectively. An absolute threshold is the smallest stimulus intensity that the subject can detect; researchers typically use an accuracy level of 50 percent detection. A difference threshold (or the just noticeable difference mentioned above) is the smallest difference in intensity between two stimuli that the subject can identify [14].

The detection threshold is determined from the psychometric function, mentioned above. The psychometric function is a plot of the proportion of stimuli detected or discriminated versus the stimulus intensity. In essence, Figure 2.1 depicts the theoretical psychometric function.

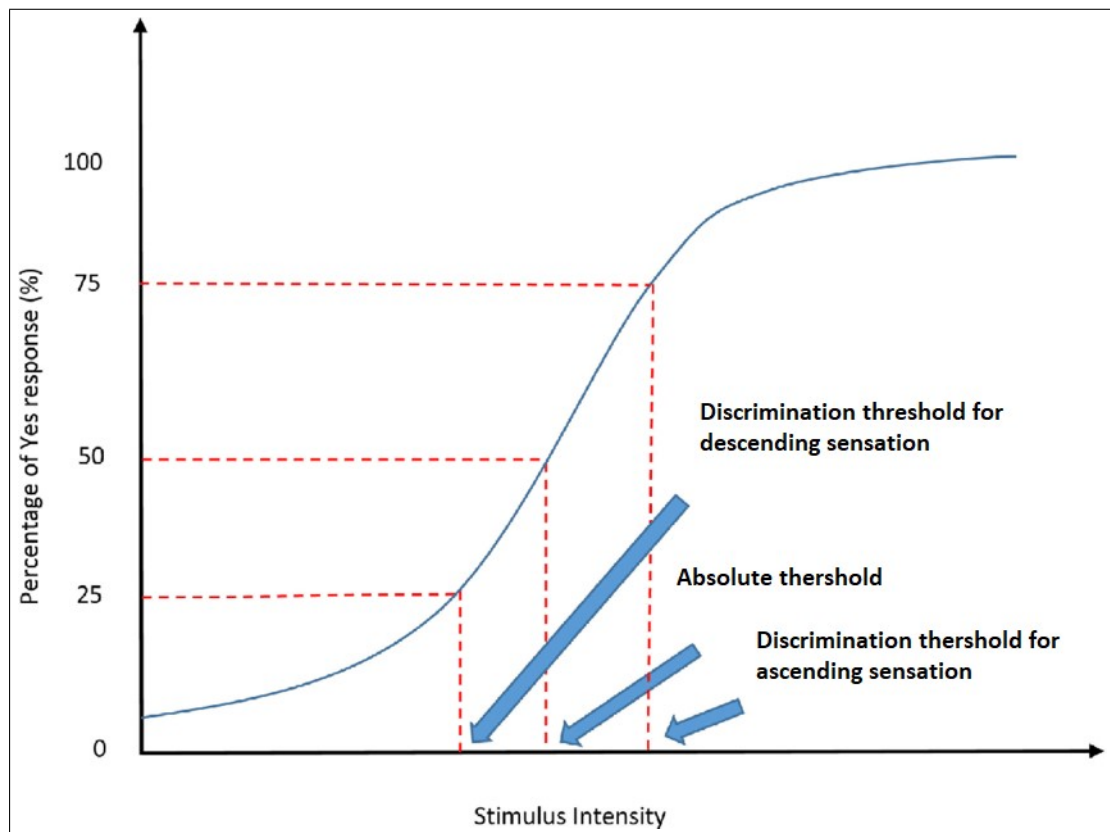

Figure 2.1 Representation of the Psychometric Function.

Three methods are typically used to measure a subject's perception of a stimulus to determine the absolute or discrimination threshold. These are the method of adjustment, the method of limits, and the method of constant stimuli [14].

In the method of adjustment, the subject is required to change the stimulus until they observe a difference against a reference stimulus or, some cases, background noise. The user then repeats this trial many times [16]. A drawback of the adjustment technique is that since the subject controls the stimulus, it can be difficult to standardize [14].

In the method of limits, the subject is exposed to comparison stimuli in gradually changing in intensity, upwards or downwards in small fixed steps. After each change in intensity, the subject reports when the subject can no longer detect or discriminate the stimuli in downward cases or when the subject begins to detect or discriminate

the stimulus. The absolute threshold is the average the stimulus intensity where the subject can identify the stimulus. The discrimination threshold is the average difference between the fixed stimulus and the final step of the comparison stimulus. Figure 2.2 depicts the experiment case for the absolute threshold [14], [17], [1].

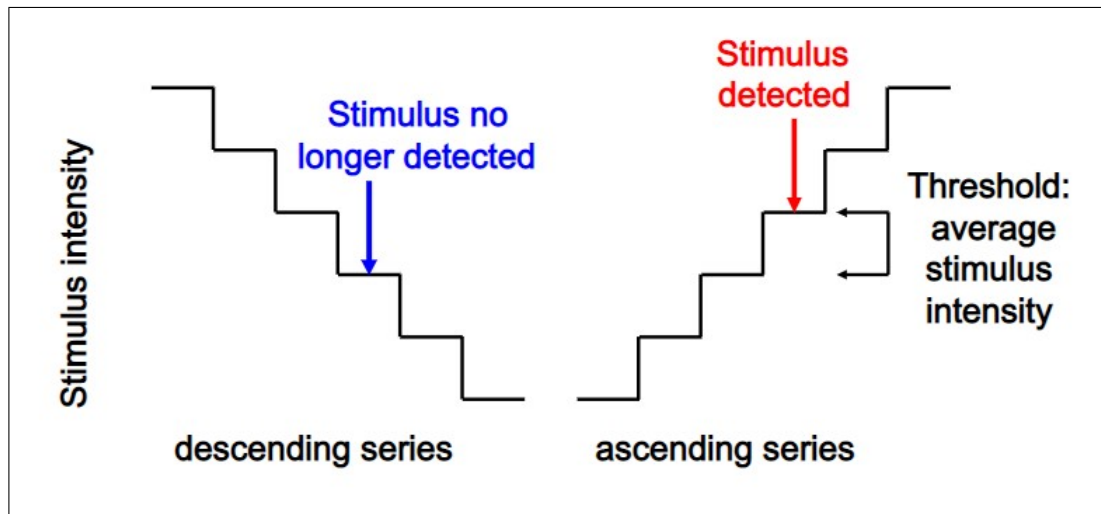

Figure 2.2 Description of the Method of Limits for Absolute Threshold [1].

In the method of constant of stimuli, the subject is exposed to various stimuli at varying intensity levels, or differences for discrimination tests) in a fixed range. The subject is presented with these stimuli multiple times in a random manner and is asked to detect each stimulus. In discrimination tasks, the subject is also presented with a comparison stimulus against a fixed comparison stimulus and is asked to differentiate the two stimuli. The subject's proportion of correct responses to total responses are then plotted against stimulus intensity, or difference to obtain the psychometric function, which is typically a sigmoid shape where the threshold of discrimination is taken at the stimulus intensity which crosses the 50 percent or 75 percent level of accuracy in the function. Figure 2.3 depicts the experiment case for the absolute threshold [14], [17], [1].

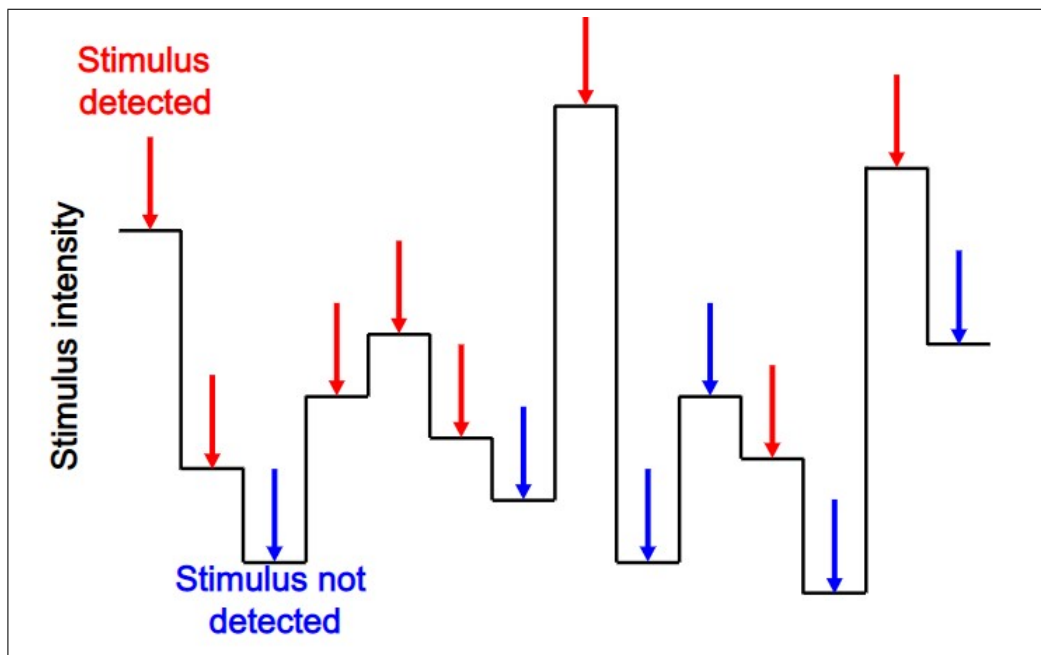

Figure 2.3 Description of the Method of Constant Stimuli for Absolute Threshold [1].

A widely used technique used for discrimination experiments is the 2 Alternative Forced Choice (2-AFC) procedure. Developed by Fechner, this method is used to assess where the proportion of discriminating a stimulus between two intensities reduces to chance [13]. In a 2-AFC task, the subject is presented with two stimuli intensities, where one of the stimulus alternatives in each trial is a fixed stimulus and the other changes in a fixed range. The subject is then asked to discriminate between the two stimuli. The proportion of correct responses is then plotted against stimulus intensity to obtain the psychometric curve as depicted in Figure 2.4 [18]. In the 2-AFC procedure, the percentages in the psychometric function range from 50 percent to 100 percent. That is because as the stimulus intensity becomes too small to detect, and the subject starts guessing the answer. The probability of correctly identifying the difference in stimulus intensity by chance is 50 percent for two alternatives. Researchers typically use a discrimination accuracy of 75 percent of the time for the discrimination threshold [2].

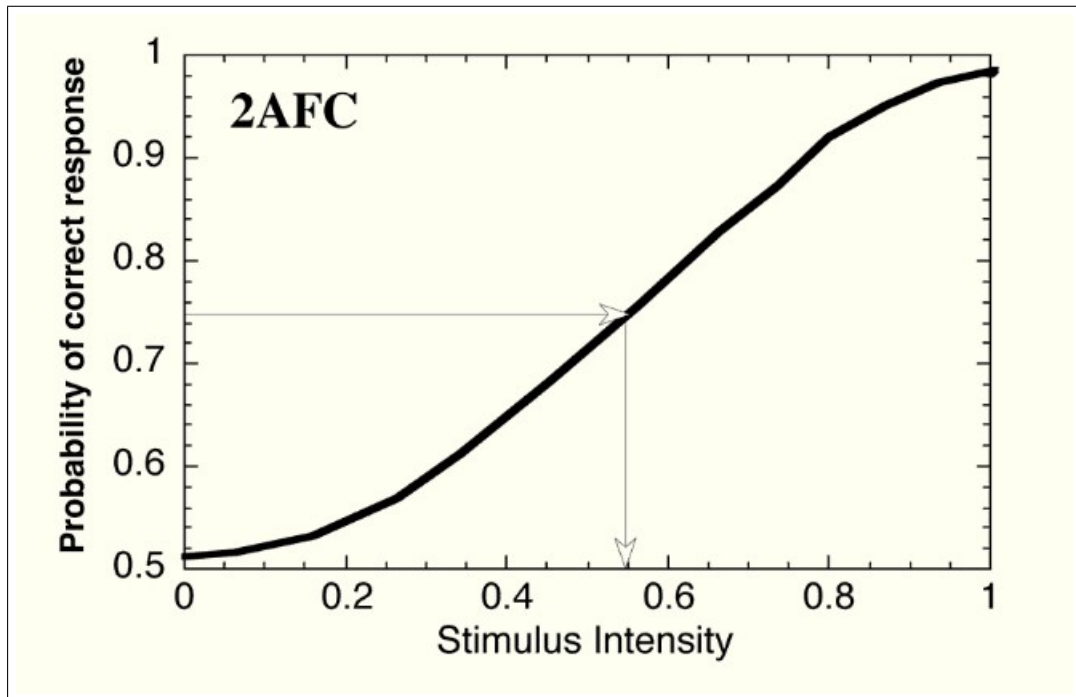

Figure 2.4 Psychometric Function in 2-AFC Procedures [2].

2.2 Simulation Environments

Starting in the 1930s virtual simulation environments were designed and used in training pilots for military aircraft; the Link Flight Trainer was the de facto pilot trainer of the time which was an electromechanical simulator controlled by motors that linked to the rudder and steering column to modify the pitch and roll. This technology later turned into modern flight simulators [19]. In the 1960s, virtual reality headsets gained traction. The Headsight, developed in 1961, was the first headset that could track motion through a video screen for each eye and a magnetic motion tracking system, which was linked to a closed-circuit camera [20]. The Headsight was used for immersive remote viewing of dangerous situations by the military. In 1965, Ivan Sutherland published his seminal paper where he described “the ultimate display” that could simulate reality to the point where one could not tell the difference from actual reality.³ The 1980s were a great time for virtual reality immersive technologies such as virtual reality goggles and gloves like VPL Research’s EyePhone HRX [21]. However,

these technologies were expensive and not very user-friendly. As computing power increased in the early 2000s, there was a leap in virtual reality technologies, and today we see many immersive virtual reality technologies on the market in industries such as the military, gaming, cinema, education, and many others. This leap has also changed the robotics industry, today we can see robots in many of these industries, much of which is designed in virtual environments. Medical applications of virtual environments include virtual surgery rooms and visual patient simulations for physician education and the design of biomedical robotics such as the Da Vinci Surgery table and robotic prosthetics.

Virtual environments have allowed designers to greatly reduce the costs of robot development and have also allowed the researcher's platforms to develop virtual environments for scientific research and professional training. Among these robot simulation environments, the Gazebo simulation environment stands out because it is a well-maintained open-source platform. The gazebo simulator is focused on environment design capable of simulating physical situations such as interactions between objects (grab, push, etc.).

The Gazebo software is a 3D dynamic simulator with the ability to accurately and efficiently simulate populations of robots in complex indoor and outdoor environments [22]. The Gazebo simulation software is maintained by Open Source Robotics Foundation, an active open source community. Figure 2.5 depicts the simulation environment of an example world in the Gazebo simulator.

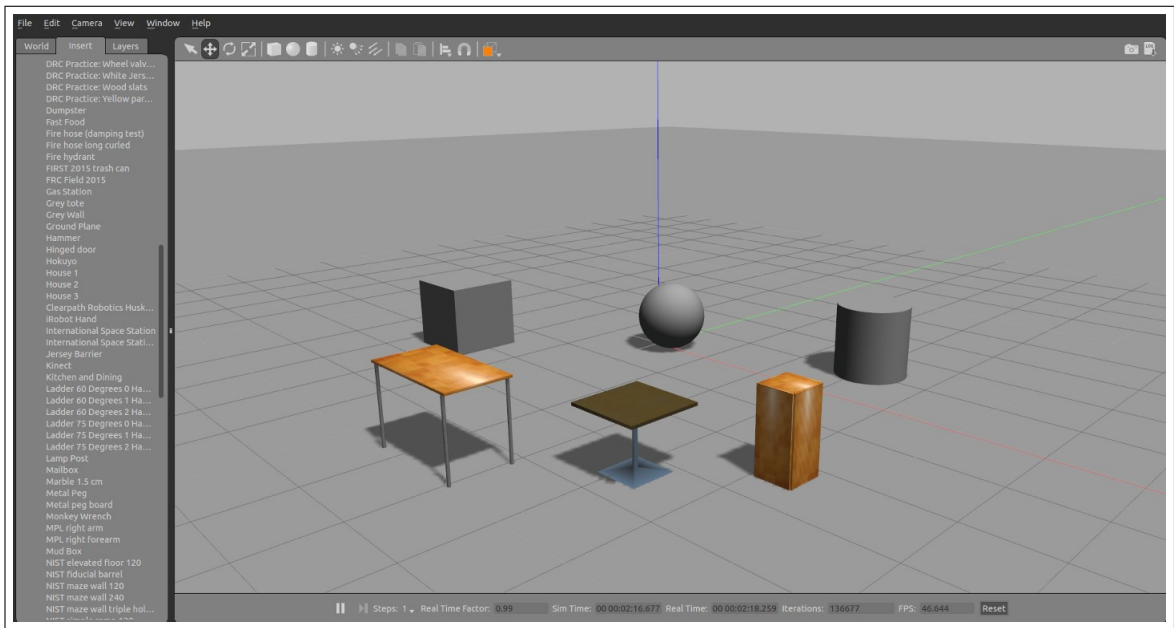

Figure 2.5 Gazebo World Example.

3. METHODS

3.1 The Virtual Environment

This thesis presents a design of a virtual environment where a subject's threshold for stiffness discrimination of a series of look-alike objects with varying stiffnesses against a control object can be derived using visual and audio stimuli.

The virtual environment was designed using the Gazebo simulator. The Gazebo simulation software running on a Linux operating system was used to develop a virtual environment for interactions of objects. The environment includes objects of different stiffnesses, and the user attempts to discriminate between these objects. Data from the virtual environment was then extracted and outputted via the computer's sound card. Finally, six subjects used the virtual environment for stiffness discrimination. There were six cubes which are similar on the outside but have different stiffnesses, where the stiffest cube was used as the reference object. The subjects were asked to discriminate between these objects and the reference object, and we plotted the psychometric curve and determined the discrimination threshold from the data produced.

The virtual environment is composed of three objects: a probing device, a cube, and a slider. The probing device is used to touch the cube which moves on the slider. The slider is used to constrain the movement of the cube. The cube is used as the object, which is "touched" by the probe to generate a response force. Figure 3.1 shows the virtual environment.

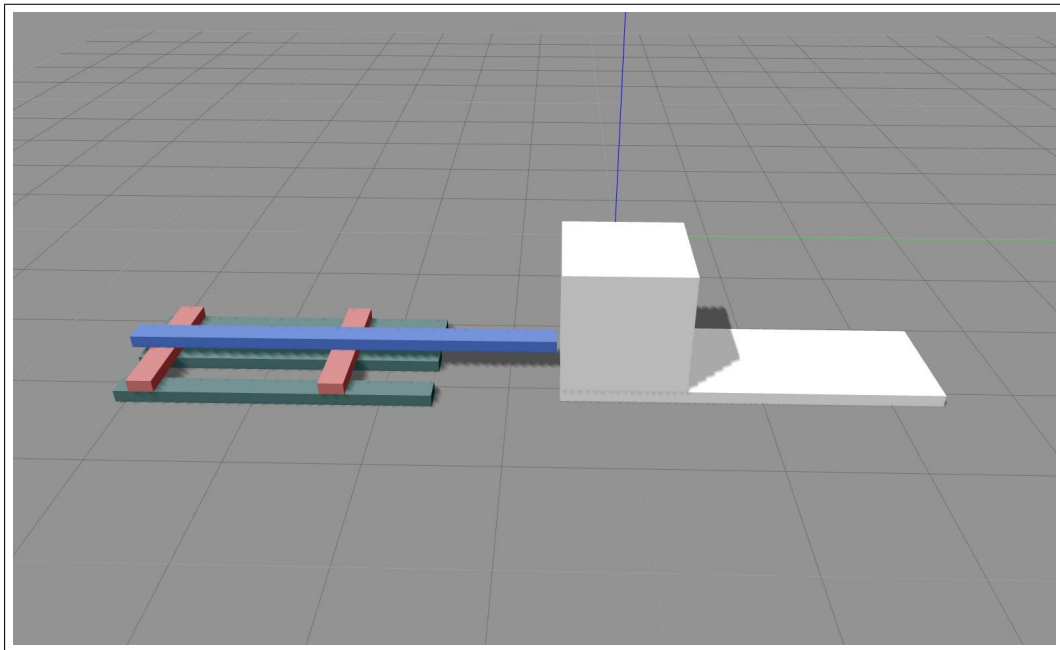

Figure 3.1 The Virtual Environment on the Gazebo Simulator when it is started.

Due to constraints in the Gazebo simulation environment, we were not able to directly deform the object. To simulate the effect of deformation, we modeled the cube as a mass-spring-damper system, so the object generates a force proportional to the distance it is pushed by force generated from the probe “touching” the box. The k constant of the spring was manipulated in each trial to simulate the perception of “touching” objects with different stiffness properties. Figure 3.2 shows the virtual environment while the probe is “touching” cube.

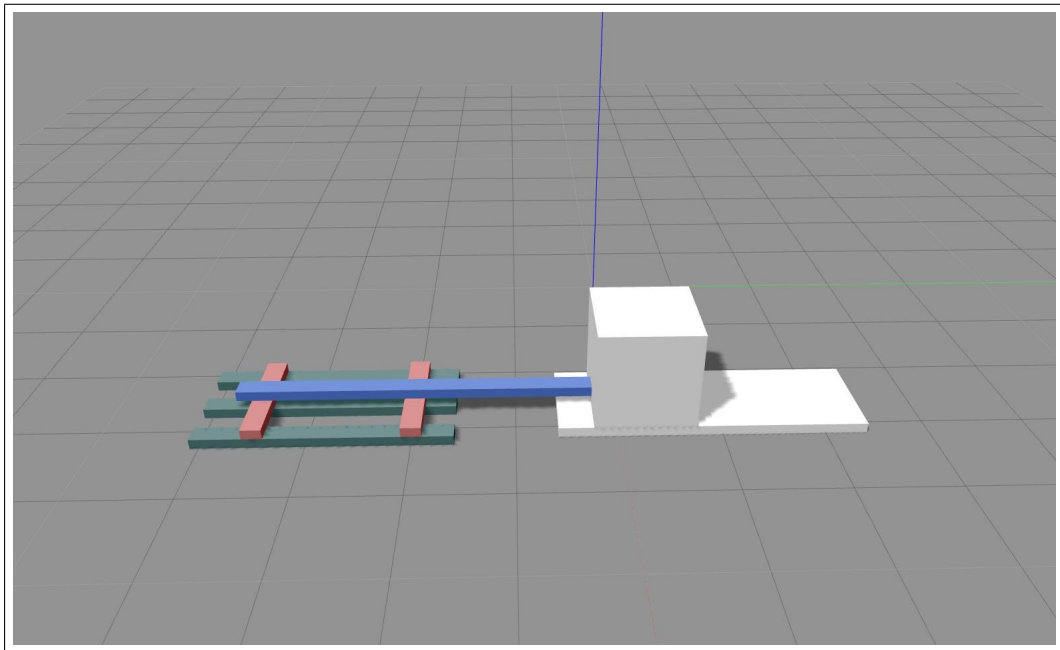

Figure 3.2 The Virtual Environment on the Gazebo Simulator when the probe is in contact with the cube.

We chose the mass-spring-damper model because a second-order system provided a step response where the rise time of the step response reduces as we increased the k constant of the spring as in the nature of the psychometric function.

Mihelj and Podobnik describe a parallel connection of a spring with stiffness k , and a damper with viscosity b is the most common way of modeling a stiff and grounded surface. Figure 3.3 depicts such a system where the viscous damping acts as a directed damper that is active during “touch” and passive when contact is broken. They explain that this enables realistic contact rendering [3].

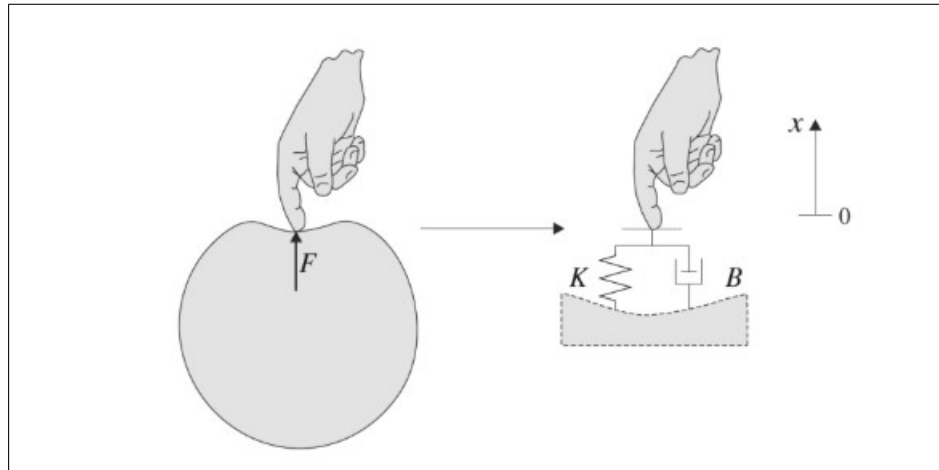

Figure 3.3 Spring-Damper model of contact [3].

A mass-spring-damper system is a second-order system, which has a spring and a damper attached to a mass, m , which moves laterally [4]. The forces which act on the box are shown in the free-body diagram of the system in Figure 3.4. The force generated the spring by extending is proportional to motion in the x -direction, determined by Hooke's law:

$$F_k = kx \quad (3.1)$$

where k is the spring constant and x is the distance extended.

The damper generates a force proportional to the velocity of movement in the x -direction:

$$F_b = b \frac{dx}{dt} \quad (3.2)$$

where b is the damping constant, x is the distance extended, and t is time.

The system of the equation of motion is then the sum of the forces generated by the spring and the damper, which, according to Newton's second law equals the mass times acceleration of the cube. In standard form, the equation becomes:

$$m \frac{d^2x}{dt^2} + b \frac{dx}{dt} + kx = F_{ext} \quad (3.3)$$

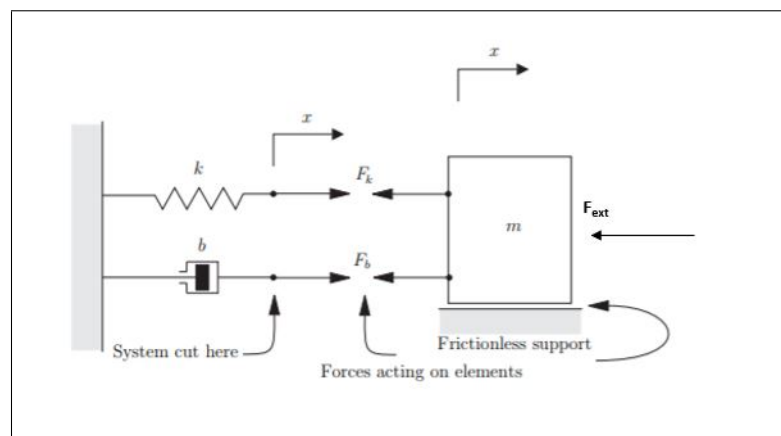

Figure 3.4 Free-Body Diagram of mass-spring-damper [4].

In determining the response of a second-order system, the pole locations are identified in terms of the damping ratio and natural frequency. The natural frequency, ω_n , is the frequency at which the system oscillates when damping of the system is zero.

The damping ratio, ζ , is the ratio of the actual damping to the critical damping. The damping ratio describes the decay of oscillations following a disturbance to the system. The system is described as:

$$\frac{1}{\omega_n^2} \frac{d^2x}{dt^2} + \frac{2\zeta}{\omega_n} \frac{dx}{dt} + x = 0 \quad (3.4)$$

When Eq. 3.3 is solved, the damping ratio, ζ , and the natural frequency, ω_n , can be

defined in terms of the variable in Eq. 3.3.

$$\omega_n = \sqrt{\frac{k}{m}} \quad (3.5)$$

and

$$\zeta = \frac{b}{2\sqrt{km}} \quad (3.6)$$

The response of the second-order system to a step input depends whether the system is overdamped ($\zeta > 1$), critically damped ($\zeta = 1$), or underdamped ($0 \leq \zeta < 1$). The response of each case to a step input is depicted in Figure 3.5. This is important because in the simulation, the probe is moved with a fixed force, and so acts as a step input to the system. The step response of the system, in this case, should be that of a second-order system [4].

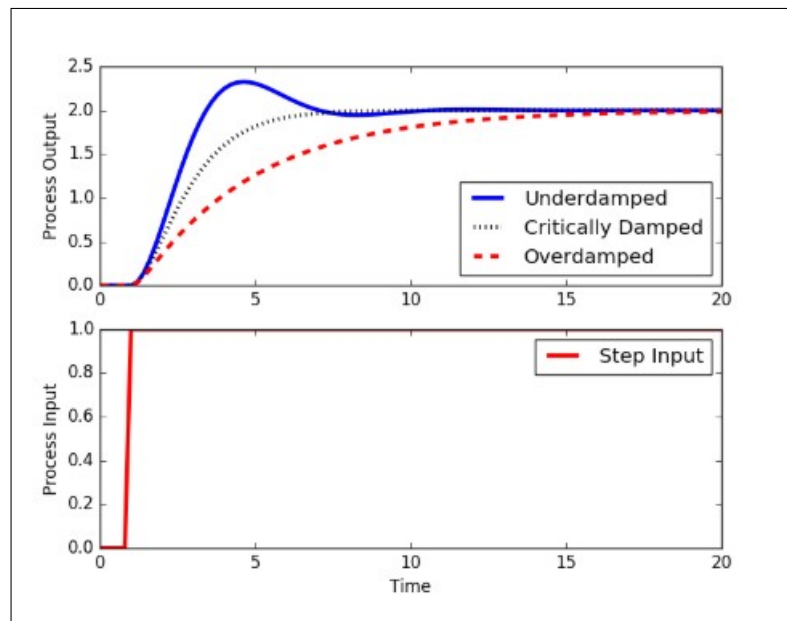

Figure 3.5 Step responses of a second-order system.

The Gazebo simulation environment is composed of a Gazebo Server and Gazebo Client. Once the Gazebo simulator is started, the Gazebo World and Gazebo Models are loaded into the Gazebo Server. We control the Gazebo simulation environment

through nodes which also publish the force and displacement data from the simulation to a text file.

The virtual environment for this thesis is controlled by two nodes, which will be referred to as the force node and contact node. The contact node defines the force sensor on the end of the probe that touches the cube. It is called the contact sensor because it is only active when the probe touches the cube and generates the sound signal based on how much the cube moves and then publishes the amplitude of the sound. The force node is used to generate the force on the probe to move and touch the cube. Also, the force node resets the position of the models after each trial and produces the message asking, “which cube is stiffer?” after each experiment. The node also functions to reset the Gazebo World for the next experiment. Figure 3.6 describes the architecture of the virtual environment and the functions of each node.

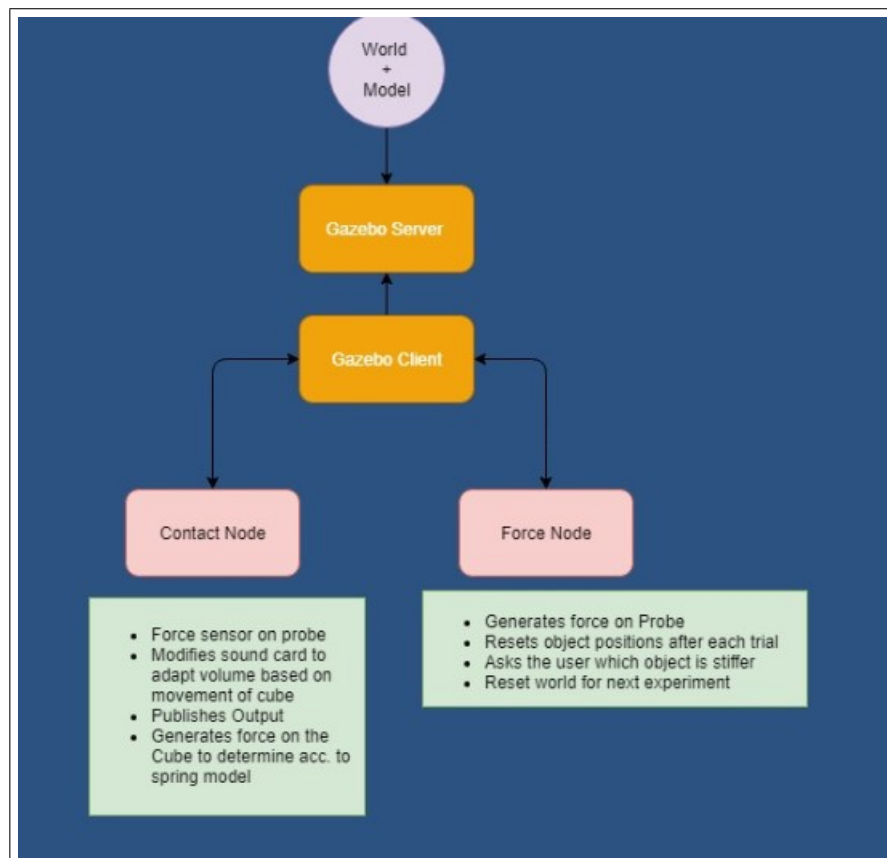

Figure 3.6 Architecture of the Virtual Environment.

The virtual environment works by starting the Gazebo simulator according to the World file configuration. Then the force node tells Gazebo to generate a force on the probe which pushes the probe to touch the cube. At this time, the contact node determines the k constant of the cube, and if the experimental or control cube should appear first. The trial then begins with the probe touching and moving the cube. When the probe touches the cube, a sound signal is generated based on how much the cube moves. This process lasts about five seconds. Then the force node resets the object position to reset the trial and generate the second cube. The trial process is repeated, and then the user is asked: “which cube is stiffer?” The user then answers, and then the Gazebo World is reset for the next experiment. Figure 3.7 shows a flow diagram of how the virtual environment works.

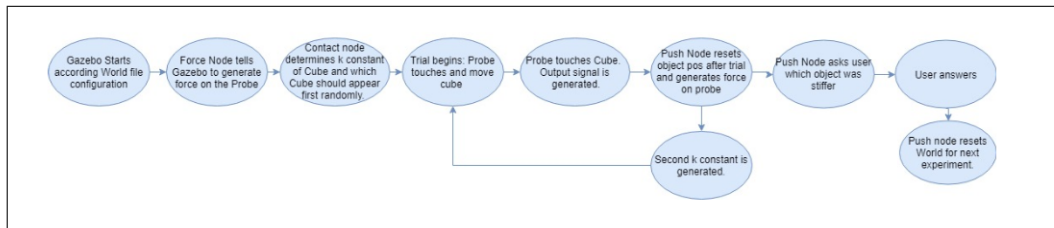

Figure 3.7 Flow diagram of Virtual Environment Experiment.

The virtual environment was designed with five different spring constants, k , and a reference constant, k_{ref} , to perform a psychophysical experiment. Each different spring constant is meant to act as a proxy value for a cube with different stiffnesses. When the cube is pushed by the probe objects with a greater k constant move further. The smaller the k value, the stiffer the object, since it would deform less under the same force. Thus, the stiffest object has the smallest k value. All of the experimental objects were able to deform more than the reference object such that $k_{ref} > k_5 > k_4 > k_3 > k_2 > k_1$. The values can be seen in Table 3.1. As the cube moves, an audio signal with increasing amplitude is produced.

Table 3.1

k constants used in the virtual environment to model stiffness.

k Constant	Value (N/m)
k_{ref}	5.0
k_1	2.4
k_2	2.7
k_3	3.1
k_4	3.5
k_5	4.1

The distance the cube moved according to each k value was linearly mapped to a value between 0-100 to standardize the numerical output of the system. As outputs, the system produces two stimuli, visual and auditory. The distance the cube moves in the environment is used as the visual stimulus and the audio signal as the auditory stimulus. The auditory range was selected to be tolerable to the user and discernable according to the Weber-Fechner law.

The step response for each k value was generated by plotting the output against time to show that the virtual environment is working properly. The step responses below (Figures 3.8-3.13) show that the output of the virtual environment is acting as the model suggests.

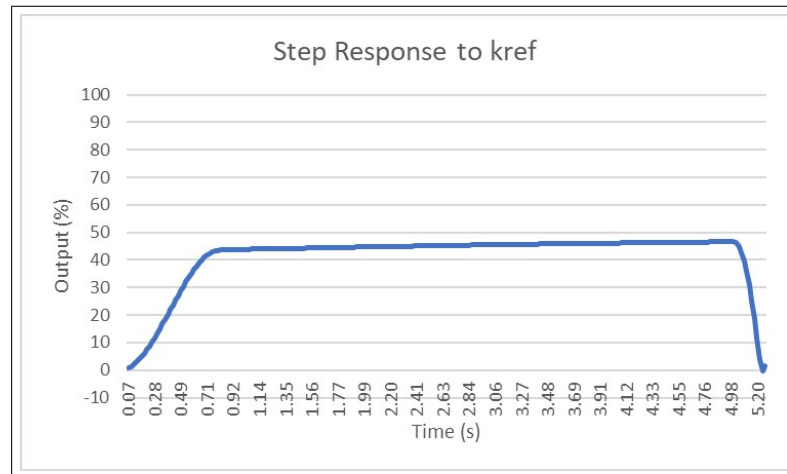

Figure 3.8 Step Response to k_{ref} .

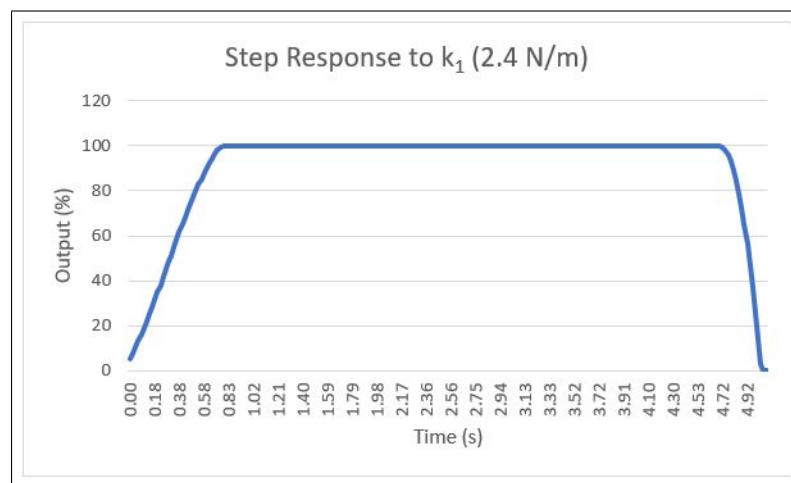

Figure 3.9 Step Response to k_1 .

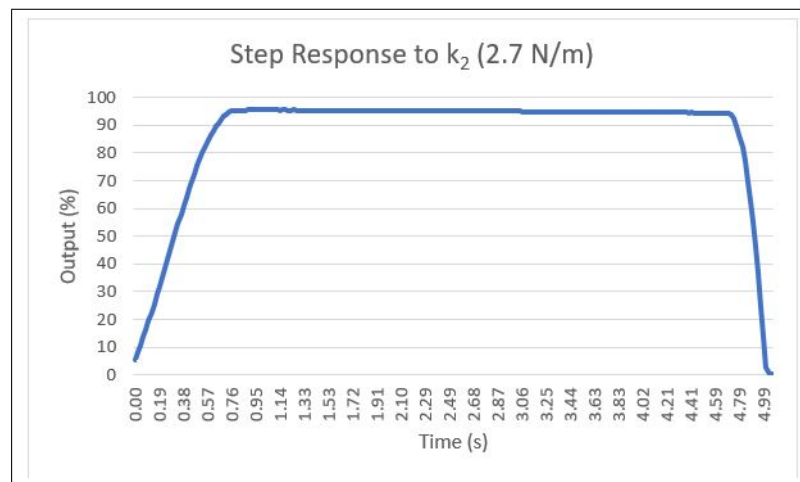

Figure 3.10 Step Response to k_2 .

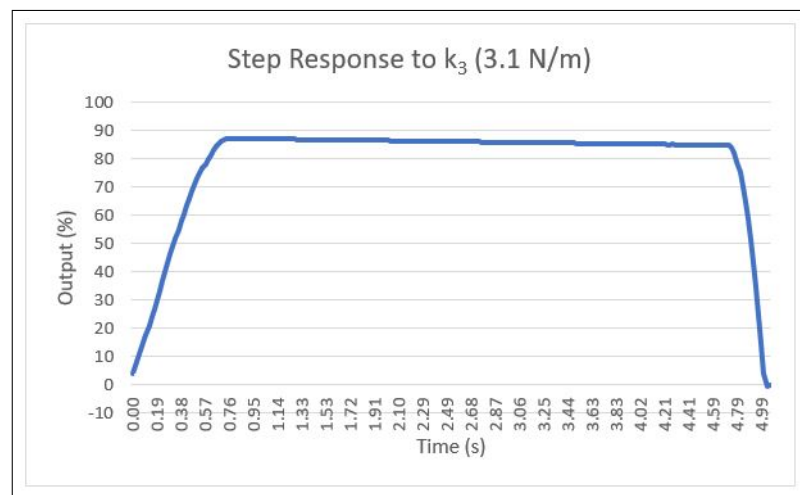

Figure 3.11 Step Response to k_3 .

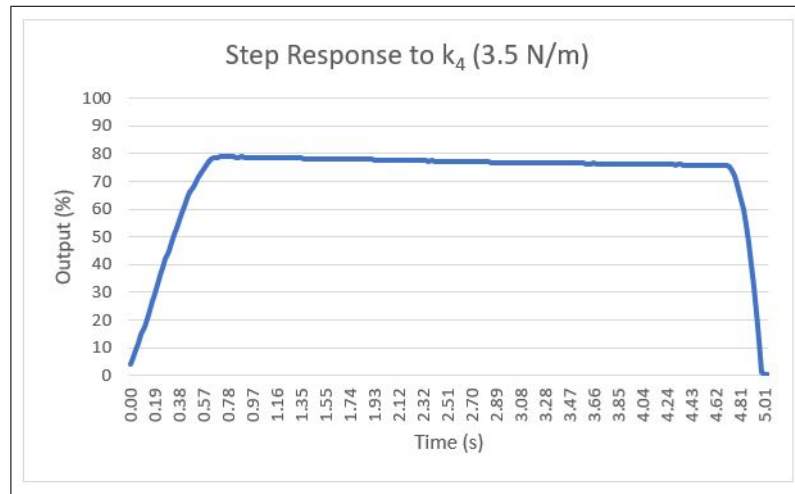

Figure 3.12 Step Response to k_4 .

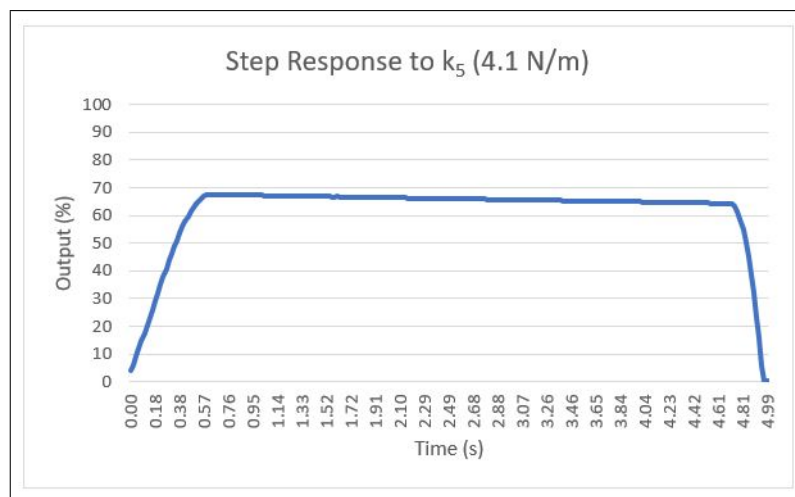

Figure 3.13 Step Response to k_5 .

3.2 The Psychophysical Experiment

The experiment was designed as a 2-Alternative Force Choice test, using the method of constant stimuli. The user was asked to determine the relative stiffness of two cubes. Of the cubes, one of them was the cube with k_{ref} , we will call this the reference cube, and the other cube was with the other k_{exp} values, we will call this the experimental cube. The order of the cubes and the experimental cube were selected at random. Each trial was set to last about five seconds, and the stimulus for each case

was about four seconds as can be seen in the step functions. About two seconds was left between each stimulus where the probe is pushed back. The process is described in Figure 3.7. The virtual environment then asks the user to select which cube was stiffer. The virtual environment then resets for the next trial. The experiment was repeated 20 times for each user.

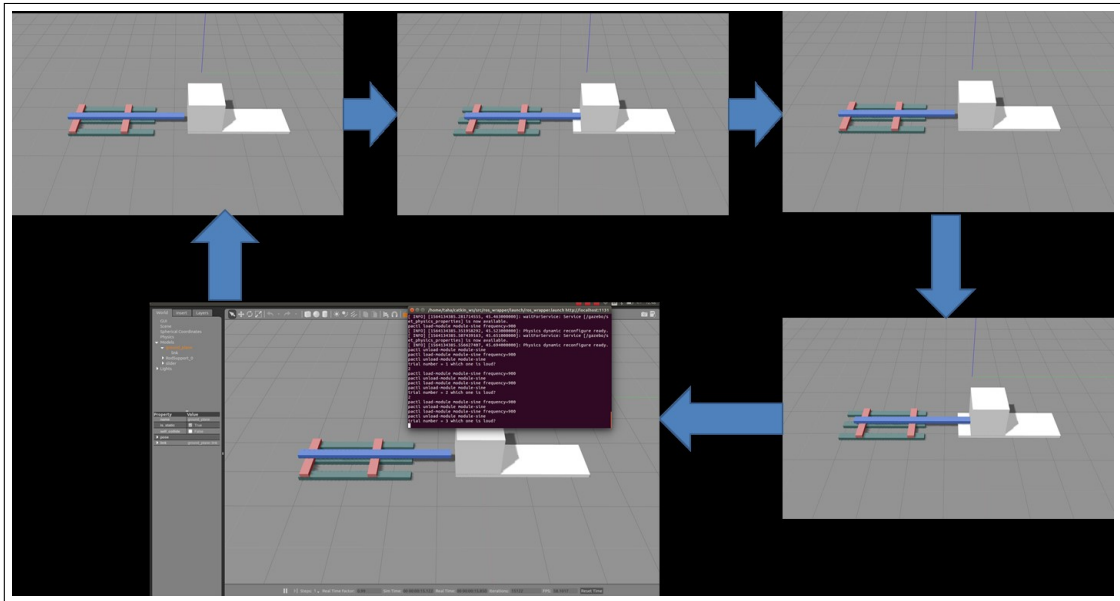

Figure 3.14 Trial in the Virtual Environment.

In the experiments, we aim to find the average discrimination threshold of the users based on the difference in k constants. Table 3.2 shows the values of each difference.

Table 3.2
Difference intervals of k (N/m) tested in the trial.

Δk	Difference Interval (N/m)
$k_{ref} - k_1$	2.6
$k_{ref} - k_2$	2.3
$k_{ref} - k_3$	1.9
$k_{ref} - k_4$	1.5
$k_{ref} - k_5$	0.9

The experiment was done in three phases. In the first phase, the user would see the virtual environment and also listen to the auditory signal. In the second phase, the user was blindfolded and only received the audio signal. In the third phase, the auditory signal of the virtual environment was muted, and the user only received the visual signal, which was the distance the cube moved. This was done to compare the response of each feedback type.

For each case, the proportion of the number of correct answers for each k_{exp} value to the total number of trials with the given k_{exp} value was plotted against the difference of each k_{exp} and k_{ref} , Δk . This was used to determine the psychometric function for each user. The 75th percentile on the curve was accepted to be the discrimination threshold or just noticeable difference of each user. The experiment was done on eight subjects. The average of these values was then used to determine an average psychometric function and discrimination threshold.

3.3 Participants

Six volunteers participated in the experiments. The subjects did not have any medical conditions which could interfere with the experiments. The procedure was approved by the Ethics Committee for Human Participants of Boğaziçi University, and it did not pose any harm to the participants.

3.4 Data analysis and Curve fitting

For each case, the proportion of the number of correct answers for each k_{exp} value to the total number of trials with the given k_{exp} value was plotted against the difference of each k_{exp} and k_{ref} , Δk . This was used to determine the psychometric function for each user. The 75th percentile on the curve was accepted to be the discrimination threshold or just noticeable difference of each user. The experiment

was done on six subjects. The average of these values was then used to determine an average psychometric function and discrimination threshold.

In plotting the psychometric curve, the data from the trials were fitted to a sigmoidal curve with nonlinear regression using the equation:

$$P_c = 0.5 + 0.5/(1 + e^{-(x-\alpha)/\beta}) \quad (3.7)$$

where P_c is the probability of correct discrimination, x is the difference in amplitude of the stimuli (N/m), α is the midpoint of the curve or discrimination threshold (N/m), and β is a parameter related to the slope ($1/\beta$) at the midpoint of the curve.

4. RESULTS

Six subjects, referred to as users, were tested using the above described Gazebo simulation to measure how they responded to changes in a cube's stiffness properties with visual and audio, only audio and only visual feedback. The users were asked to perform the 2-Alternative Forced Choice Task (2-AFC) described above with twenty repetitions of each task. Below we look at the psychometric curve and discrimination thresholds of each user for each case fit according to Eq. 3.7. All data analysis was done with MATLAB (Mathworks).

4.1 Psychometric Curve for Audio and Visual Feedback

This section analyzes the psychometric curves of each user, which performed the above-described 2-AFC task with audio and visual feedback to changes in the Cube's stiffness against the control cube with fixed stiffness.

Figure 4.1 shows the psychometric curve of User 1 for the 2-AFC task with audio and visual feedback. User 1 had a discrimination threshold of 2.09 N/m. The task showed a trend as expected, where User 1 showed a trend of identifying the difference in stiffness between the cubes as the difference in discrimination increased. However, in the cases of Δk_4 and Δk_5 where discrimination was expected to be most difficult, the results were not fitted to the curve. In larger differences, discrimination was more consistent.

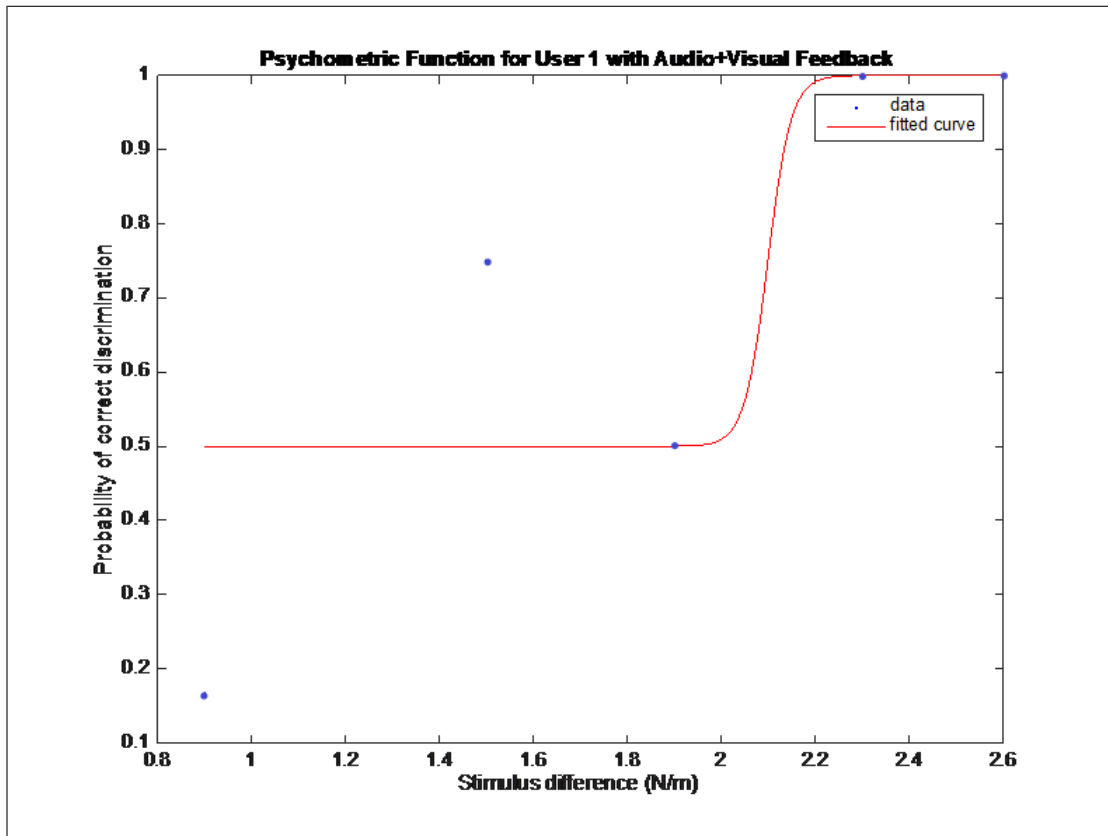

Figure 4.1 Psychometric Function for User 1 with Visual and Audio Feedback.

Figure 4.2 shows the psychometric curve of User 2 for the 2-AFC task with audio and visual feedback. User 2 had a discrimination threshold of 1.01 N/m. The task showed a trend as expected, where User 2 showed a trend of identifying the difference in stiffness between the cubes as the difference in discrimination increased. However, User 2 discriminated all of the cubes when the difference was larger than 1.5 N/m. The psychometric curve and discrimination threshold reflect that User 2 could be tested with smaller Δk values.

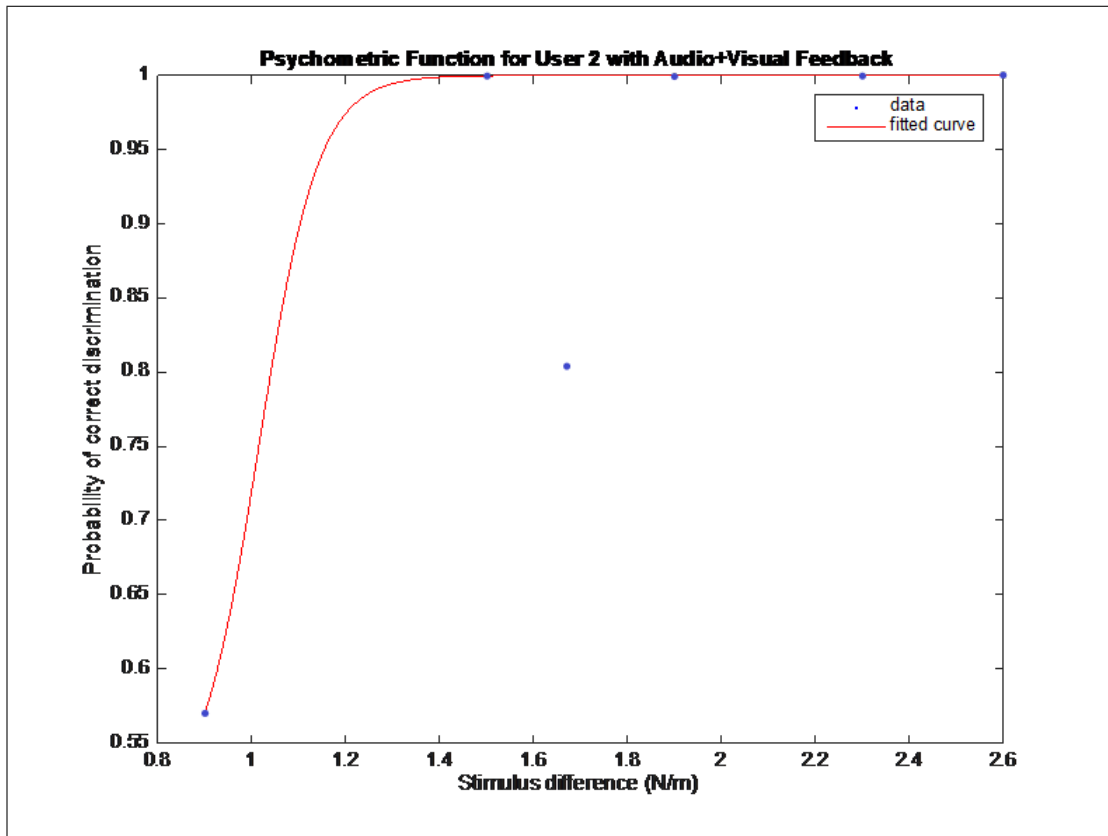

Figure 4.2 Psychometric Function for User 2 with Visual and Audio Feedback.

Figure 4.3 shows the psychometric curve of User 3 for the 2-AFC task with audio and visual feedback. User 3 had a discrimination threshold of 1.5 N/m. The task showed a trend as expected, where User 3 showed a trend of identifying the difference in stiffness between the cubes as the difference in discrimination increased. User 3 was unable to discriminate values mostly at Δk_5 ; this value may be below the perception of the subject. User 3 did better at larger differences and performed the discrimination task with 100 percent accuracy in the larger Δk values.

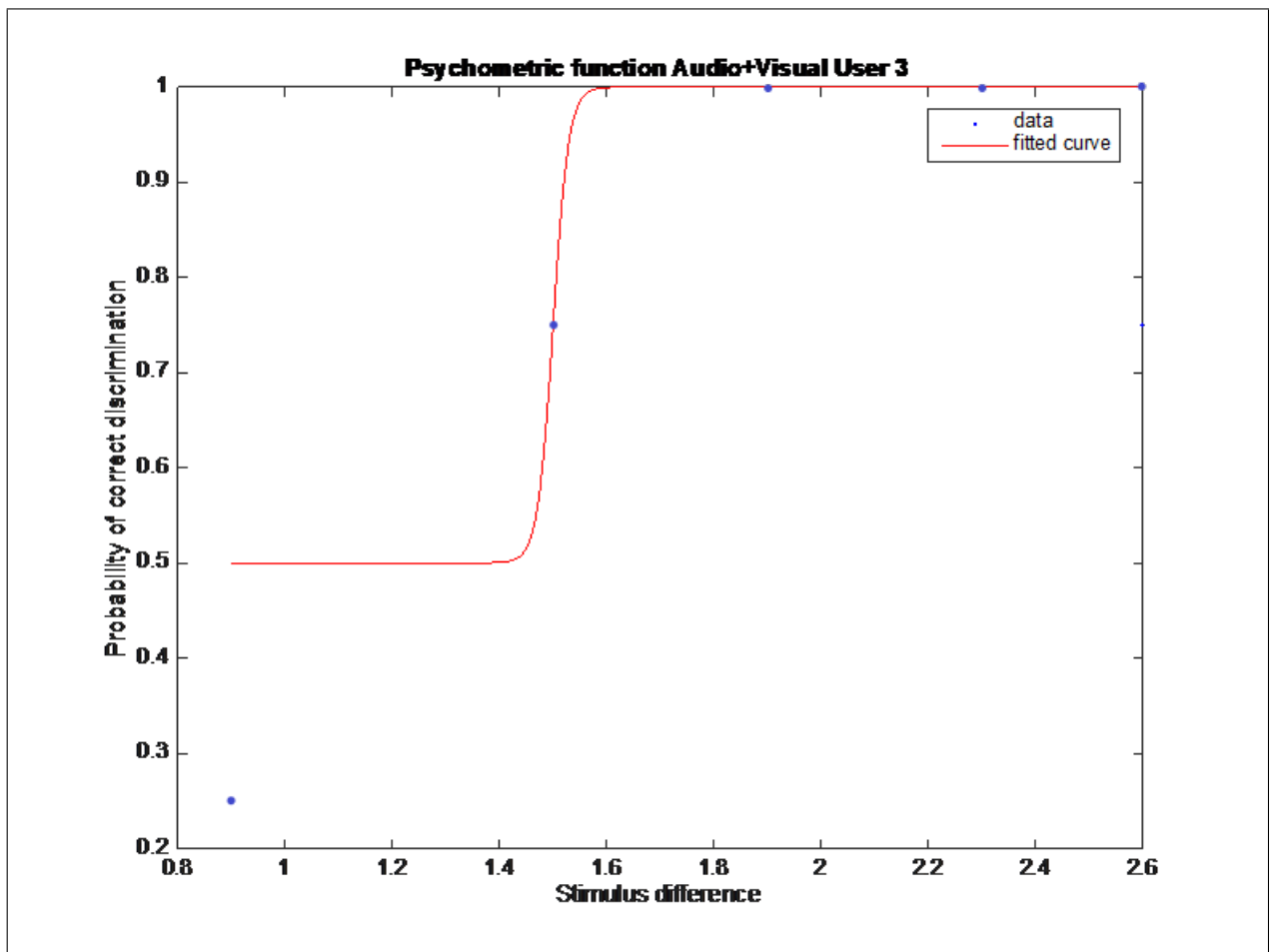

Figure 4.3 Psychometric Function for User 3 with Visual and Audio Feedback.

Figure 4.4 shows the psychometric curve of User 4 for the 2-AFC task with audio and visual feedback. User 4 had a discrimination threshold of 2.43 N/m. The task showed a trend as expected, where User 4 showed a trend of identifying the difference in stiffness between the cubes as the difference in discrimination increased.

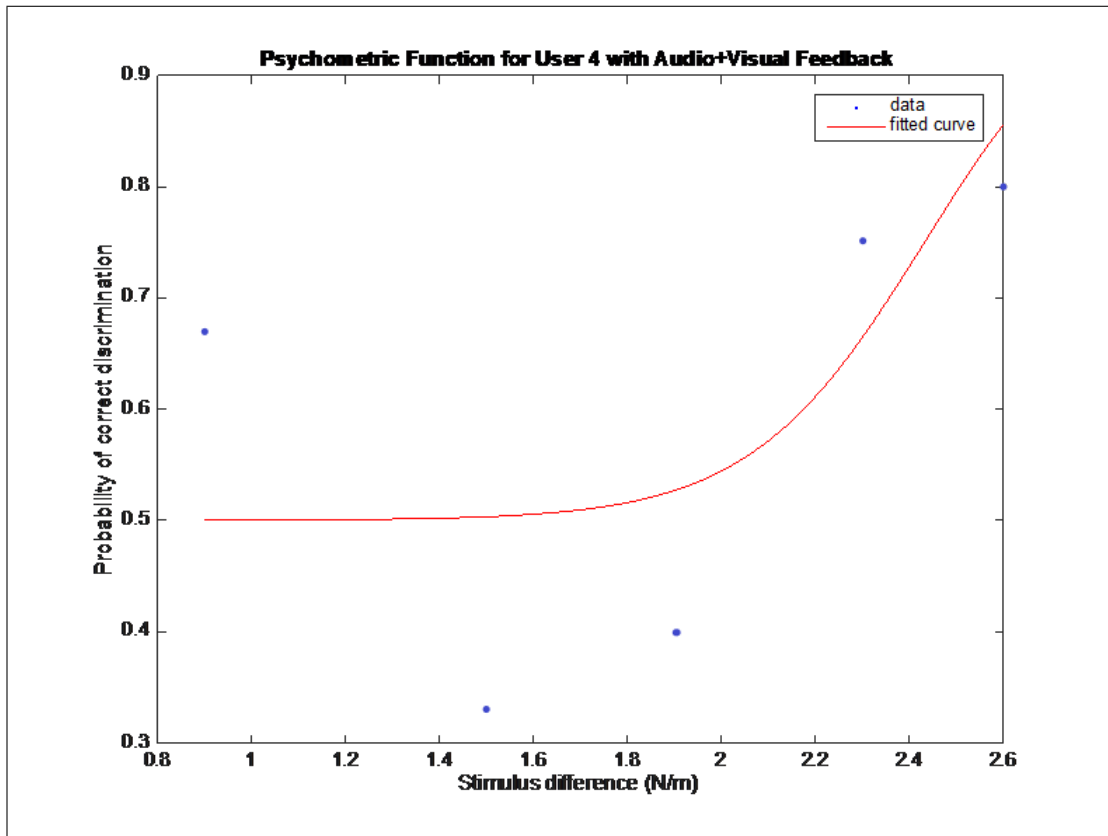

Figure 4.4 Psychometric Function for User 4 with Visual and Audio Feedback.

Figure 4.5 shows the psychometric curve of User 5 for the 2-AFC task with audio and visual feedback. User 5 had a discrimination threshold of 1.74 N/m. The task showed a trend as expected, where User 5 showed a trend of identifying the difference in stiffness between the cubes as the difference in discrimination increased. In the cases of Δk_4 and Δk_3 , User 5 showed an almost equal probability of discrimination. Thus Δk_4 and Δk_3 were not well fitted on the curve. Also, for Δk_1 and Δk_2 , User 5 discriminated performed almost all of the task correctly.

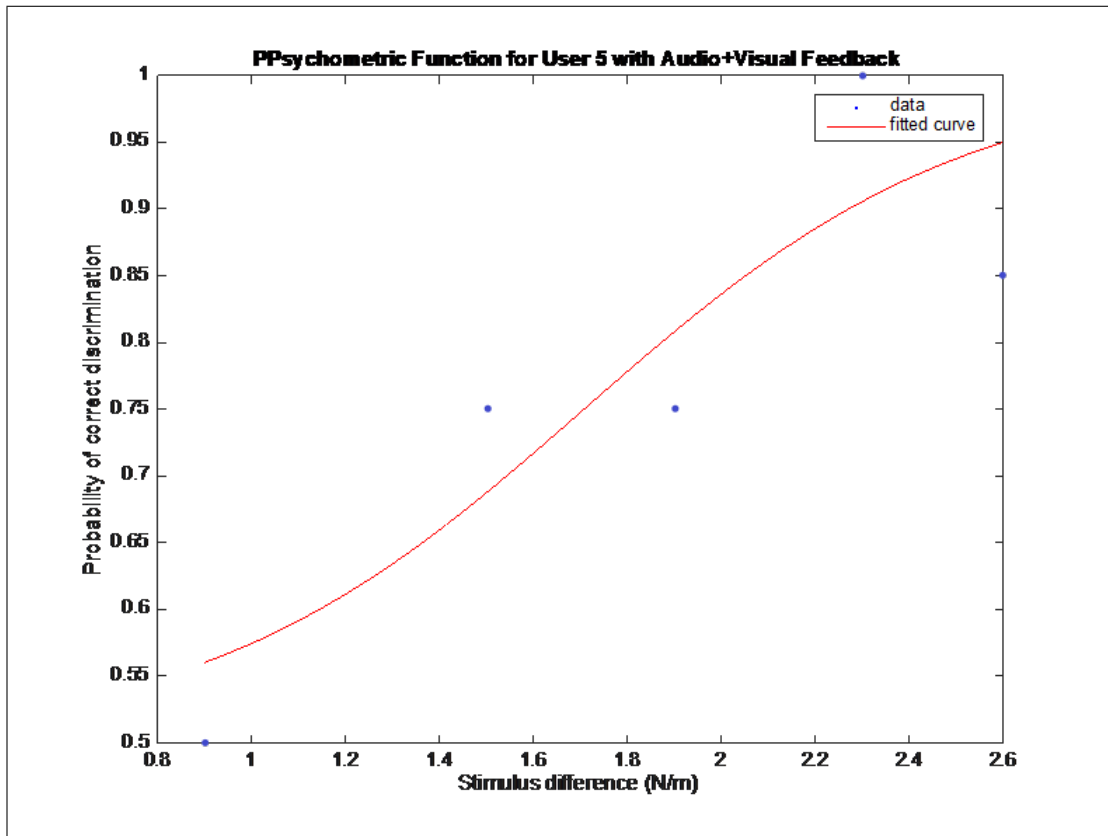

Figure 4.5 Psychometric Function for User 5 with Visual and Audio Feedback.

Figure 4.6 shows the psychometric curve of User 6 for the 2-AFC task with audio and visual feedback. User 6 had a discrimination threshold of 1.83 N/m. The task showed a trend as expected, where User 6 showed a trend of identifying the difference in stiffness between the cubes as the difference in discrimination increased. In the cases of Δk_3 , Δk_4 , and Δk_5 , User 6 showed an almost equal probability of discrimination. Thus Δk_3 , and Δk_4 were not well fitted on the curve. Also, for Δk_1 , User 6 discriminated performed all of the discrimination tasks correctly.

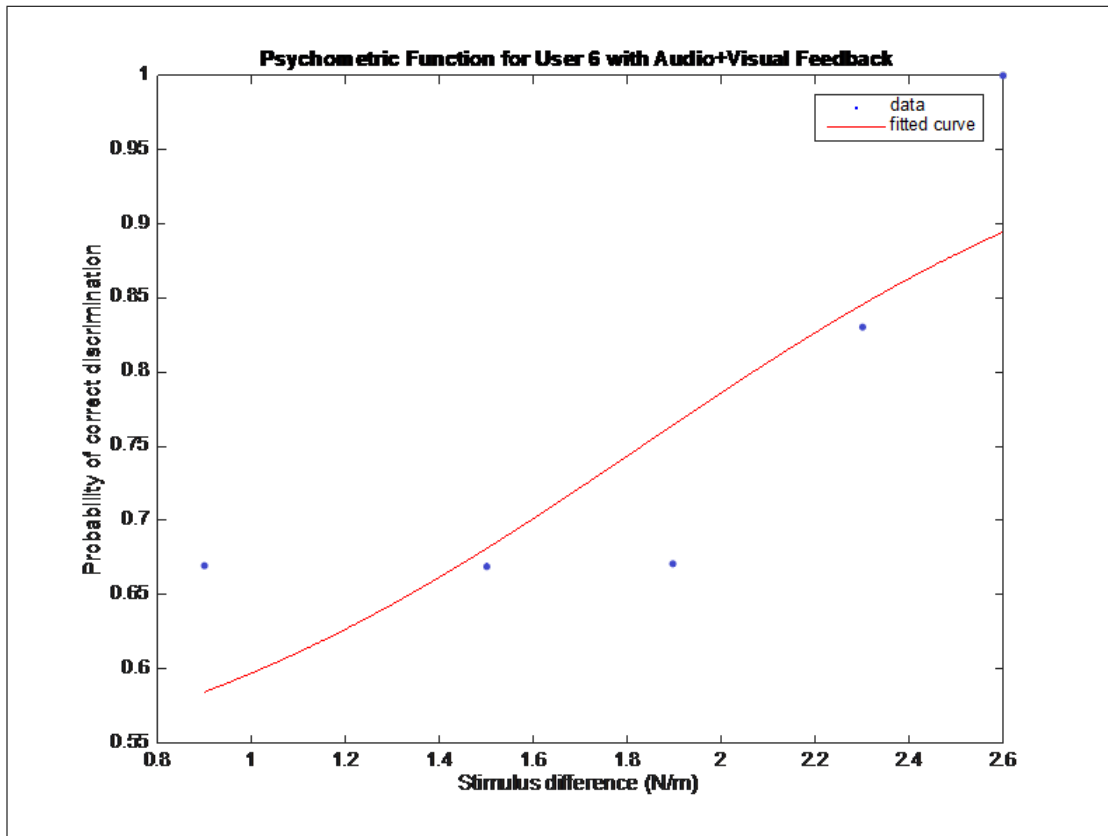

Figure 4.6 Psychometric Function for User 6 with Visual and Audio Feedback.

Table 4.1 shows a summary of discrimination thresholds found in the experiment with audio and visual feedback.

Table 4.1

Discrimination threshold of each experiment with visual and audio feedback.

User	Discrimination Threshold (N/m)
User 1	2.09
User 2	1.01
User 3	1.50
User 4	2.43
User 5	1.74
User 6	1.83

4.2 Psychometric Curves for Audio Feedback

This section analyzes the psychometric curves of each user, which performed the above-described 2-AFC task with audio feedback to changes in the Cube's stiffness against the control Cube with fixed stiffness.

Figure 4.7 shows the psychometric curve of User 1 for the 2-AFC task with audio feedback. User 1 had a discrimination threshold of 1.46 N/m. The task showed a trend as expected, where User 1 showed a trend of identifying the difference in stiffness between the cubes as the difference in discrimination increased. However, in the cases of Δk_3 and Δk_4 , Δk_4 had a larger probability of discrimination than Δk_3 , and Δk_3 was not fit on the psychometric curve. For Δk_1 , Δk_2 , and Δk_4 User 1 performed all of the discrimination tasks correctly.

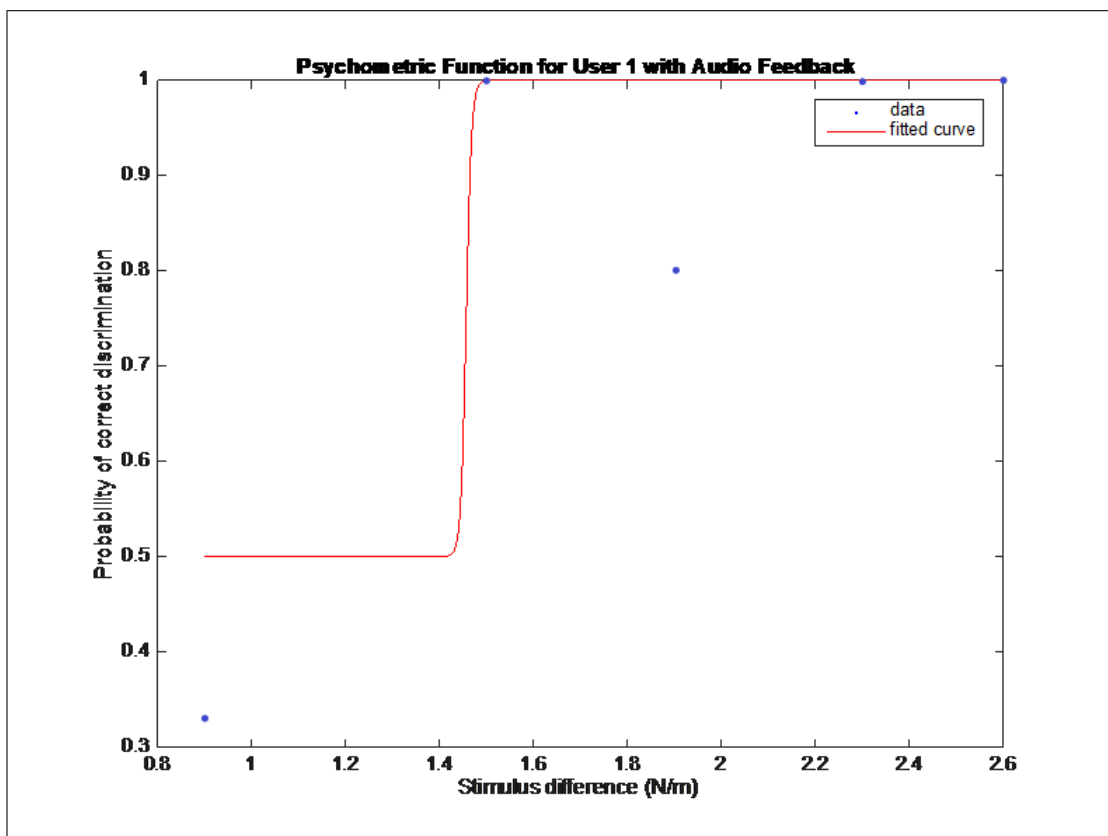

Figure 4.7 Psychometric Function for User 1 with Audio Feedback.

Figure 4.8 shows the psychometric curve of User 2 for the 2-AFC task with audio feedback. User 2 had a discrimination threshold of 0.86 N/m. The task showed a trend as expected, where User 2 showed a trend of identifying the difference in stiffness between the cubes as the difference in discrimination increased. However, User 2 performed almost all of the discrimination tasks correctly. Thus, the discrimination threshold for User was very small, and the user could have been tested with smaller Δk values.

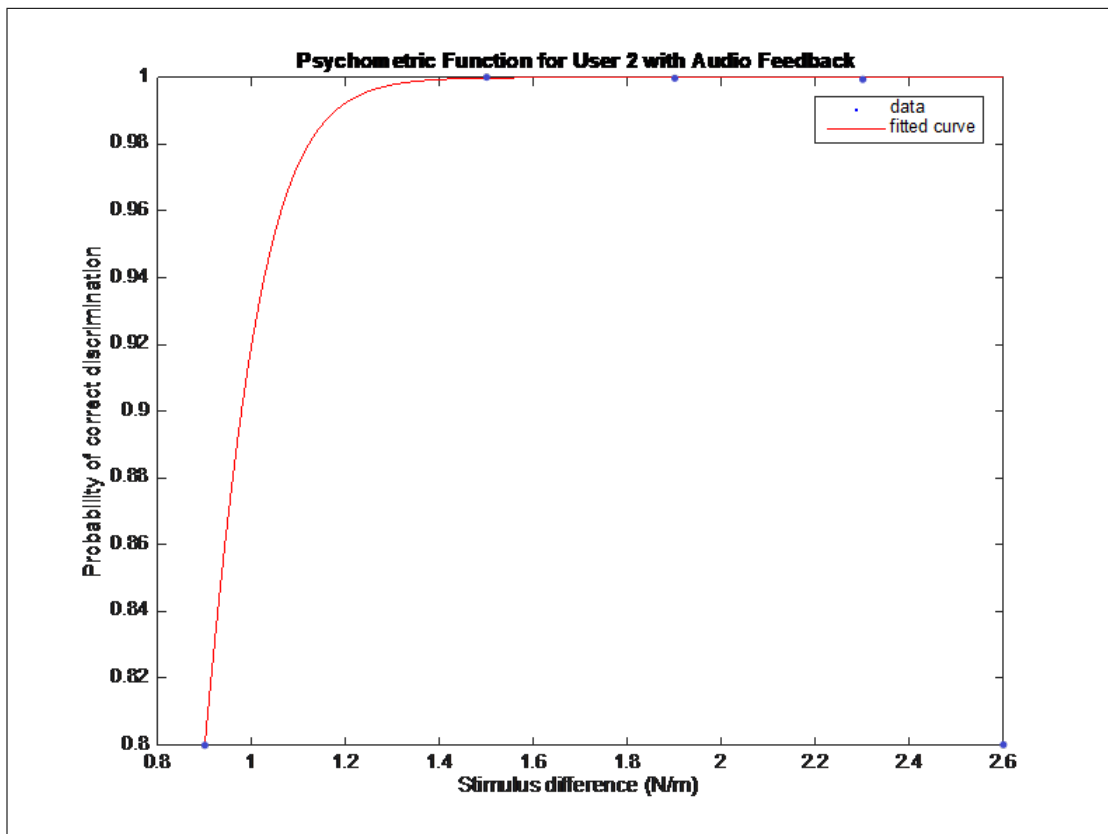

Figure 4.8 Psychometric Function for User 2 with Audio Feedback.

Figure 4.9 shows the psychometric curve of User 3 for the 2-AFC task with audio feedback. User 3 had a discrimination threshold of 2.3 N/m. The task showed a trend as expected, where User 3 showed a trend of identifying the difference in stiffness between the cubes as the difference in discrimination increased. However, in the cases of Δk_3 and Δk_4 , Δk_4 had a larger probability of discrimination than Δk_3 . Also, the probability of discrimination of Δk_3 , Δk_4 , and Δk_5 was very small, so the curve fit did not perform well.

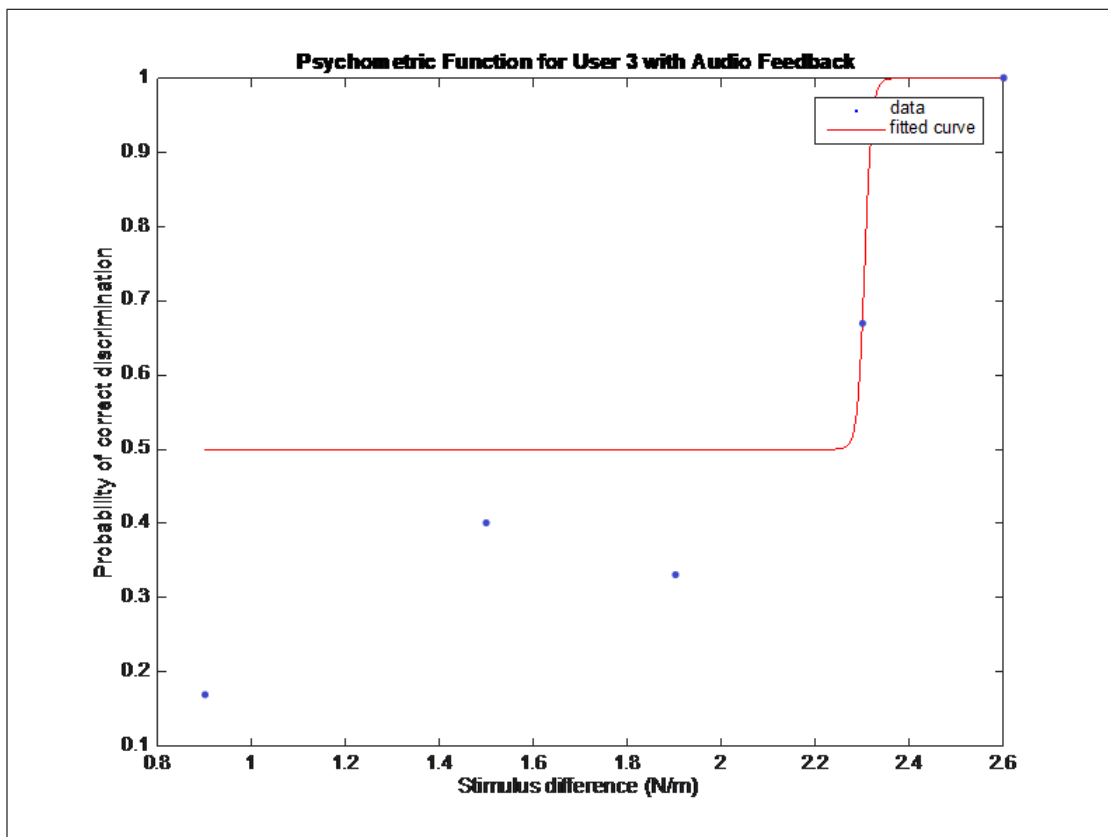

Figure 4.9 Psychometric Function for User 3 with Audio Feedback.

Figure 4.10 shows the psychometric curve of User 4 for the 2-AFC task with audio feedback. The discrimination threshold for User 4 could not be determined in these trials because no trend that showed better discrimination as Δk decreased was observed. Thus, curve fitting to Eq. 3.7 could not be performed.

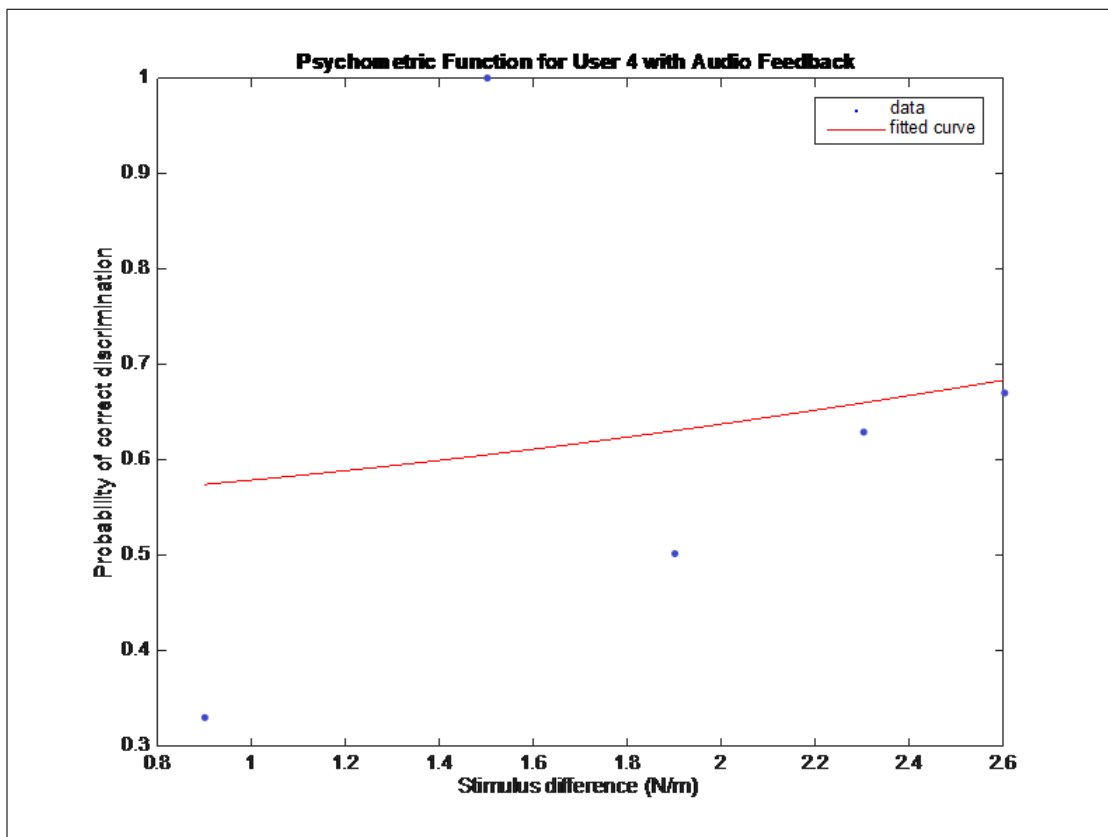

Figure 4.10 Psychometric Function for User 4 with Audio Feedback.

Figure 4.11 shows the psychometric curve of User 5 for the 2-AFC task with audio feedback. The discrimination threshold for User 5 could not be determined in these trials because no trend that showed better discrimination as Δk decreased was observed. Thus, curve fitting to Eq. 3.7 could not be performed.

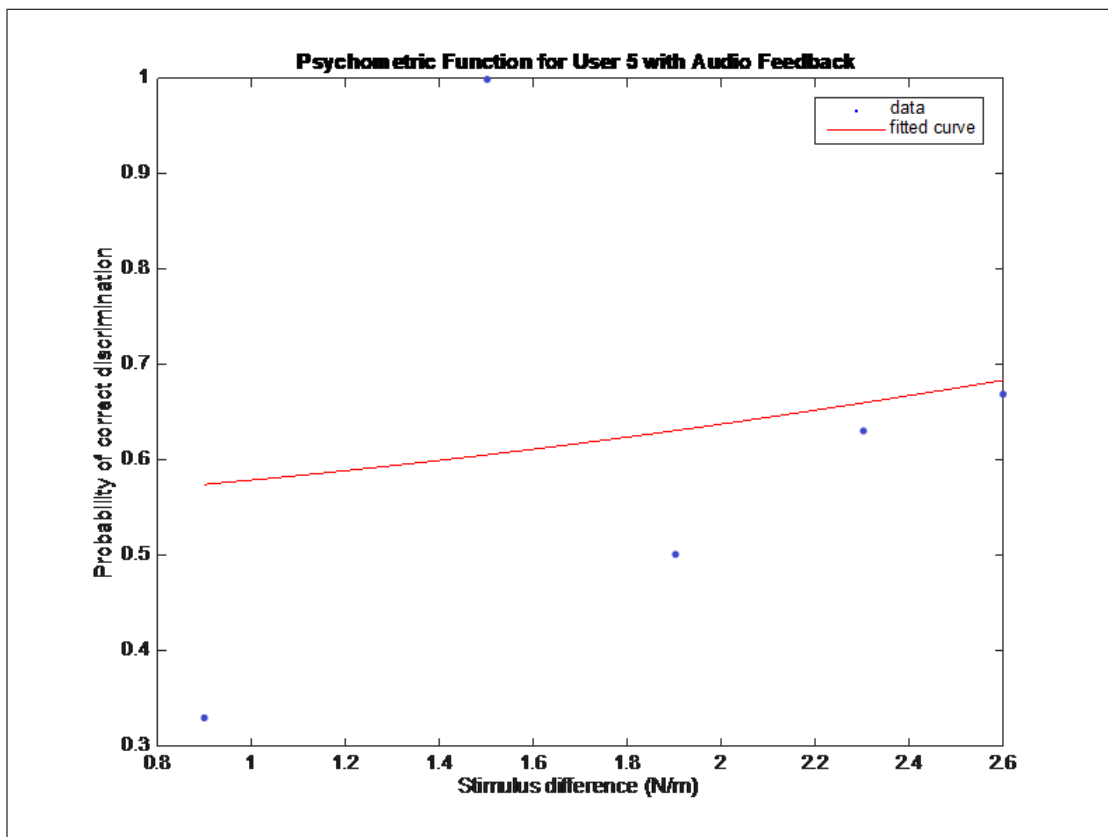

Figure 4.11 Psychometric Function for User 5 with Audio Feedback.

Figure 4.12 shows the psychometric curve of User 6 for the 2-AFC task with audio feedback. User 6 had a discrimination threshold of 2.47 N/m. The task showed a trend as expected, where User 6 showed a trend of identifying the difference in stiffness between the cubes as the difference in discrimination increased. However, in the cases of Δk_3 and Δk_4 , Δk_4 had a larger probability of discrimination than Δk_3 . Also, the probability of discrimination of Δk_5 was 0 percent; this may show that the User should be tested with larger differences.

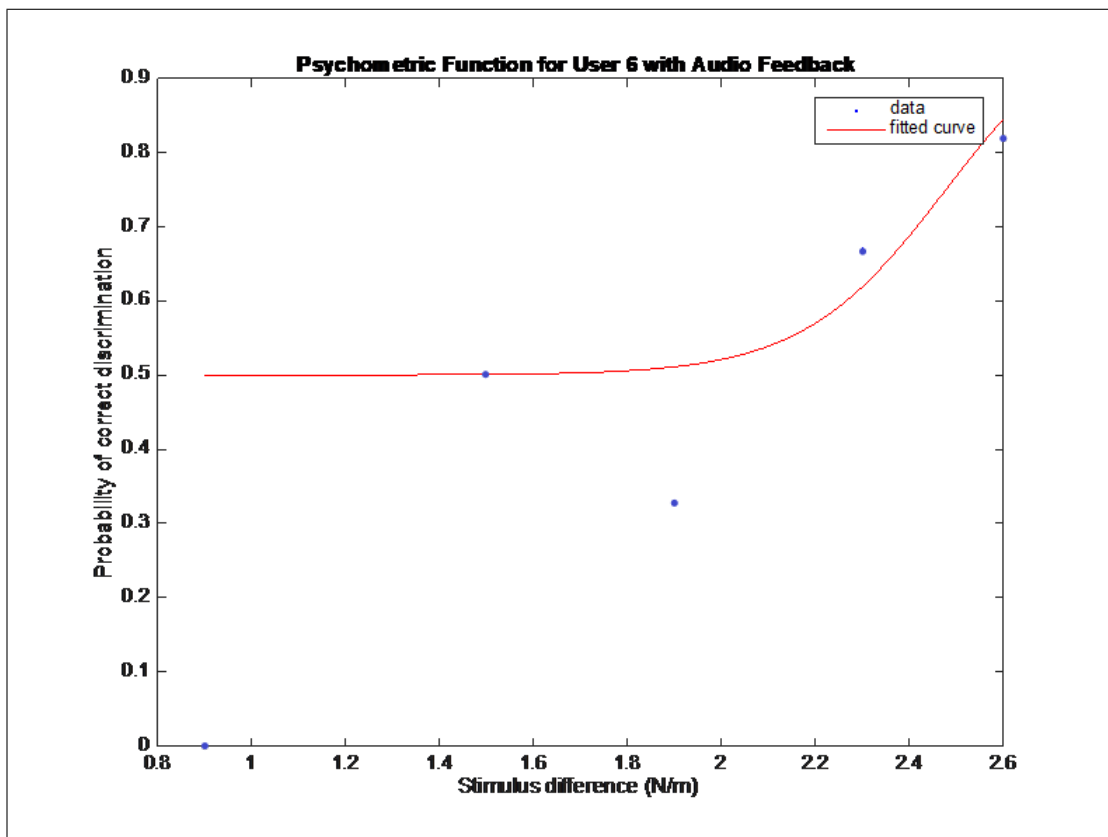

Figure 4.12 Psychometric Function for User 6 with Audio Feedback.

Table 4.2 shows a summary of discrimination thresholds found in the experiment with audio feedback.

Table 4.2
Discrimination threshold of each experiment with audio feedback.

User	Discrimination Threshold (N/m)
User 1	1.46
User 2	0.86
User 3	2.3
User 4	Could not be determined
User 5	Could not be determined
User 6	2.47

4.3 Psychometric Curves for Visual Feedback

This section analyzes the psychometric curves of each user, which performed the above-described 2-AFC task with visual feedback to changes in the Cube's stiffness against the control Cube with fixed stiffness.

Figure 4.13 shows the psychometric curve of User 1 for the 2-AFC task with visual feedback. The discrimination threshold for User 1 could not be determined in these trials because no trend that showed better discrimination as Δk decreased was observed. The user was successful in discriminating between the cubes in almost all tasks with an accuracy of greater than 75 percent in all tasks. Thus, curve fitting could not be performed.

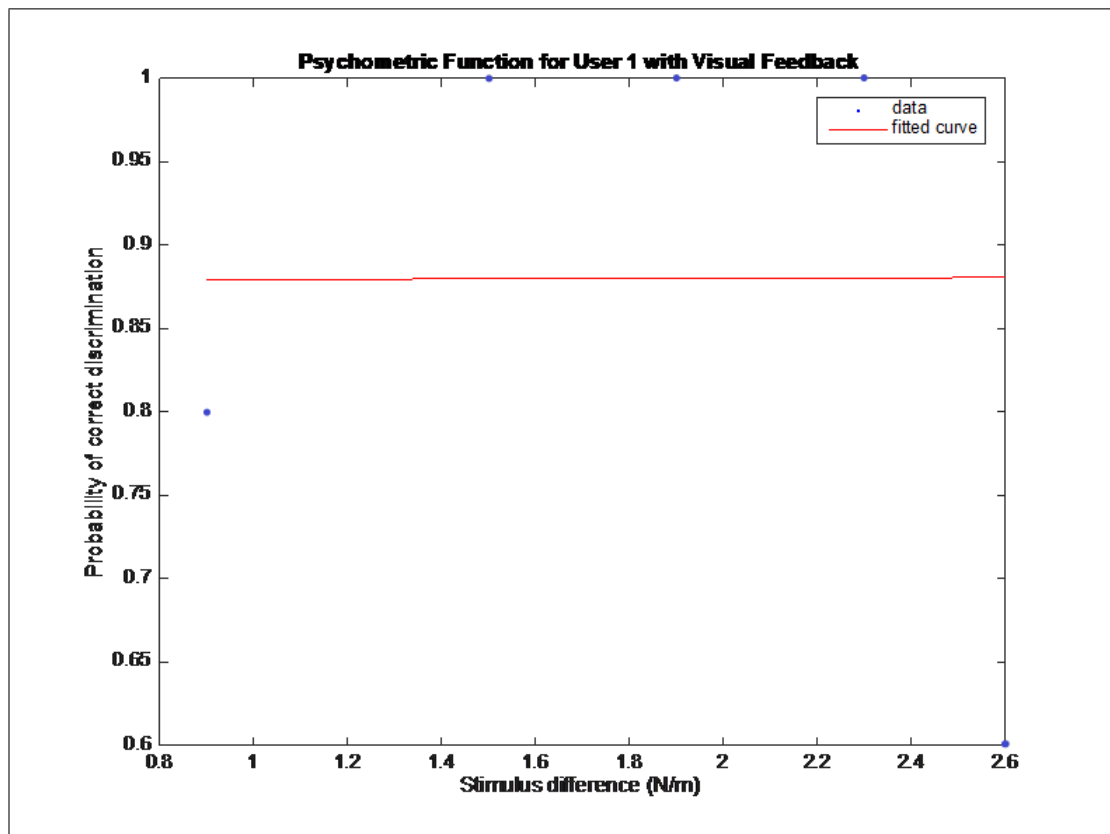

Figure 4.13 Psychometric Function for User 1 with Visual Feedback.

Figure 4.14 shows the psychometric curve of User 2 for the 2-AFC task with

visual feedback. User 2 had a discrimination threshold of 0.98 N/m. The task showed a trend as expected, where User 2 showed a trend of identifying the difference in stiffness between the cubes as the difference in discrimination increased. Discrimination tasks with Δk_5 were as expected, with a probability of discrimination of 60 percent. However, in the larger differences, User 2 answered all of the discrimination tasks correctly. Thus, the discrimination threshold for User 2 was very small, and the user could have been tested with smaller Δk values.

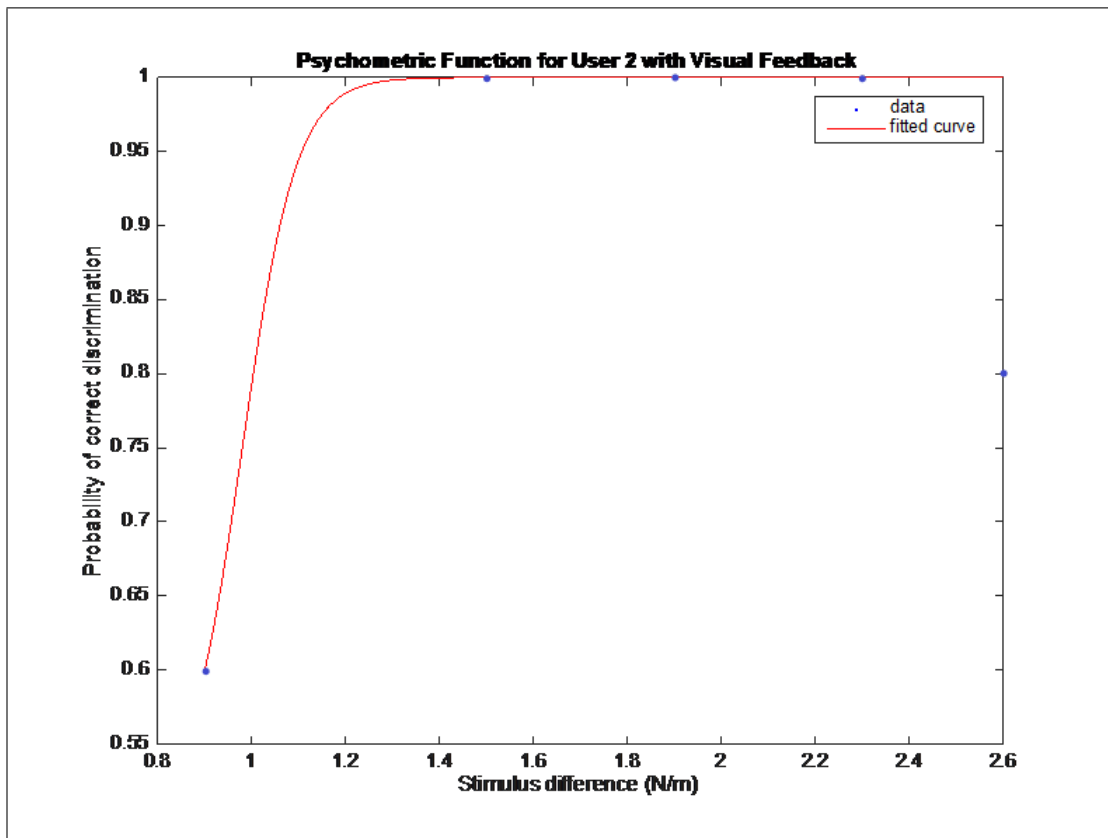

Figure 4.14 Psychometric Function for User 2 with Visual Feedback.

Figure 4.15 shows the psychometric curve of User 3 for the 2-AFC task with visual feedback. User 3 had a discrimination threshold of 0.95 N/m. The task showed a trend as expected, where User 3 showed a trend of identifying the difference in stiffness between the cubes as the difference in discrimination increased. Discrimination tasks with Δk_5 had a probability of discrimination of 67 percent. And, in the larger differences, User 3 performed all of the discrimination tasks correctly.

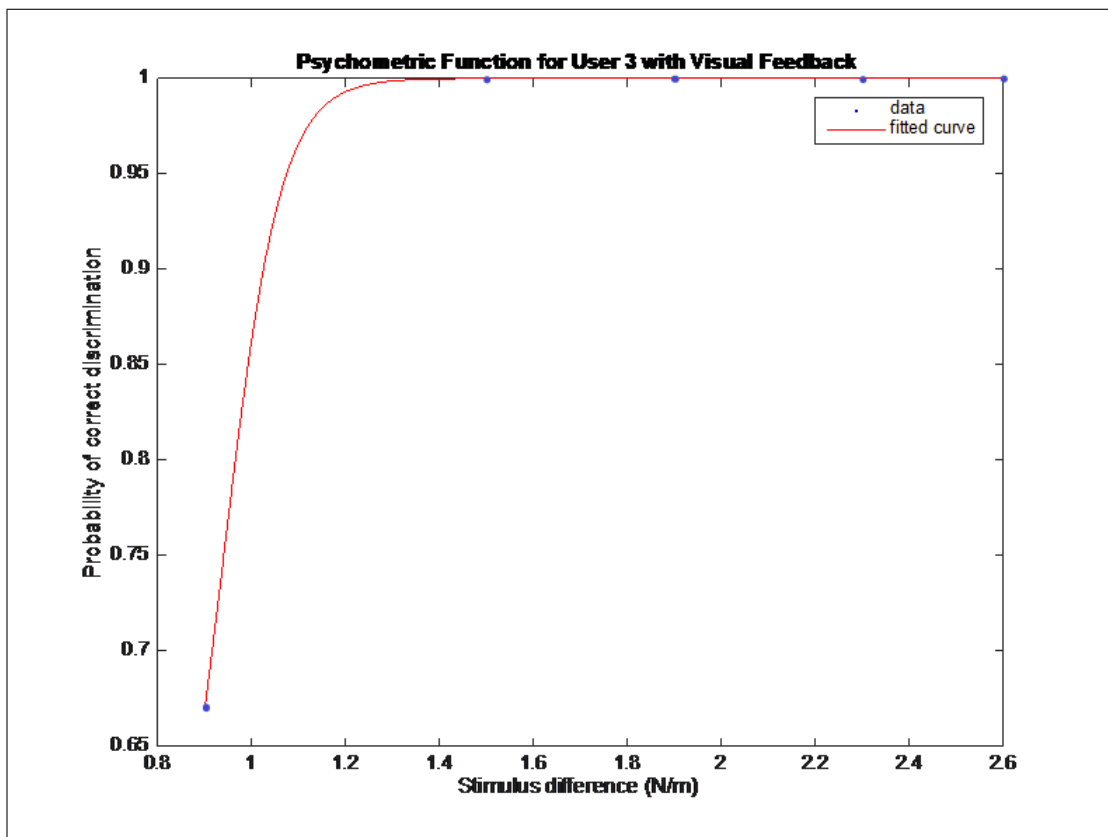

Figure 4.15 Psychometric Function for User 3 with Visual Feedback.

Figure 4.16 shows the psychometric curve of User 4 for the 2-AFC task with visual feedback. User 4 discrimination threshold could not be determined since the user correctly completed all tasks with an accuracy of greater than 75 percent. The task showed a trend as expected, where User 4 showed a trend of identifying the difference in stiffness between the cubes as the difference in discrimination increased.

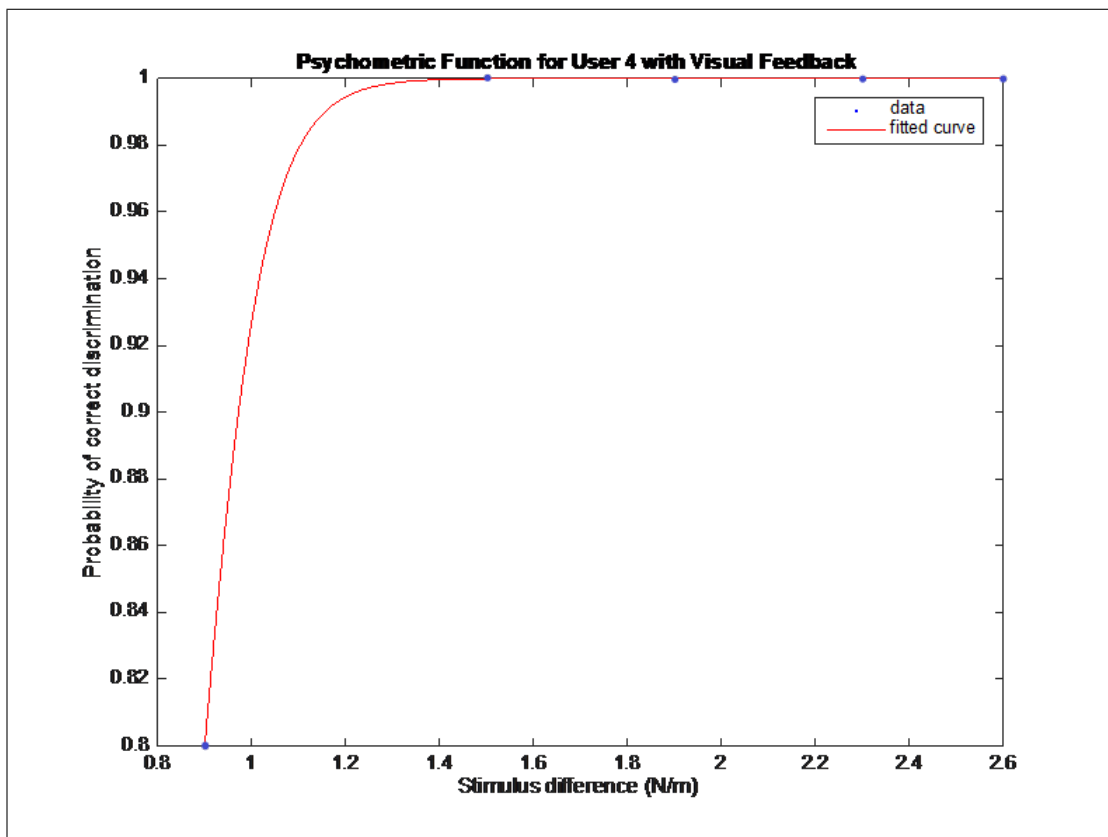

Figure 4.16 Psychometric Function for User 4 with Visual Feedback.

Figure 4.17 shows the psychometric curve of User 5 for the 2-AFC task with visual feedback. User 5 discrimination threshold could not be determined since the user correctly completed all tasks with an accuracy of greater than 75 percent. The task showed a trend as expected, where User 5 showed a trend of identifying the difference in stiffness between the cubes as the difference in discrimination increased.

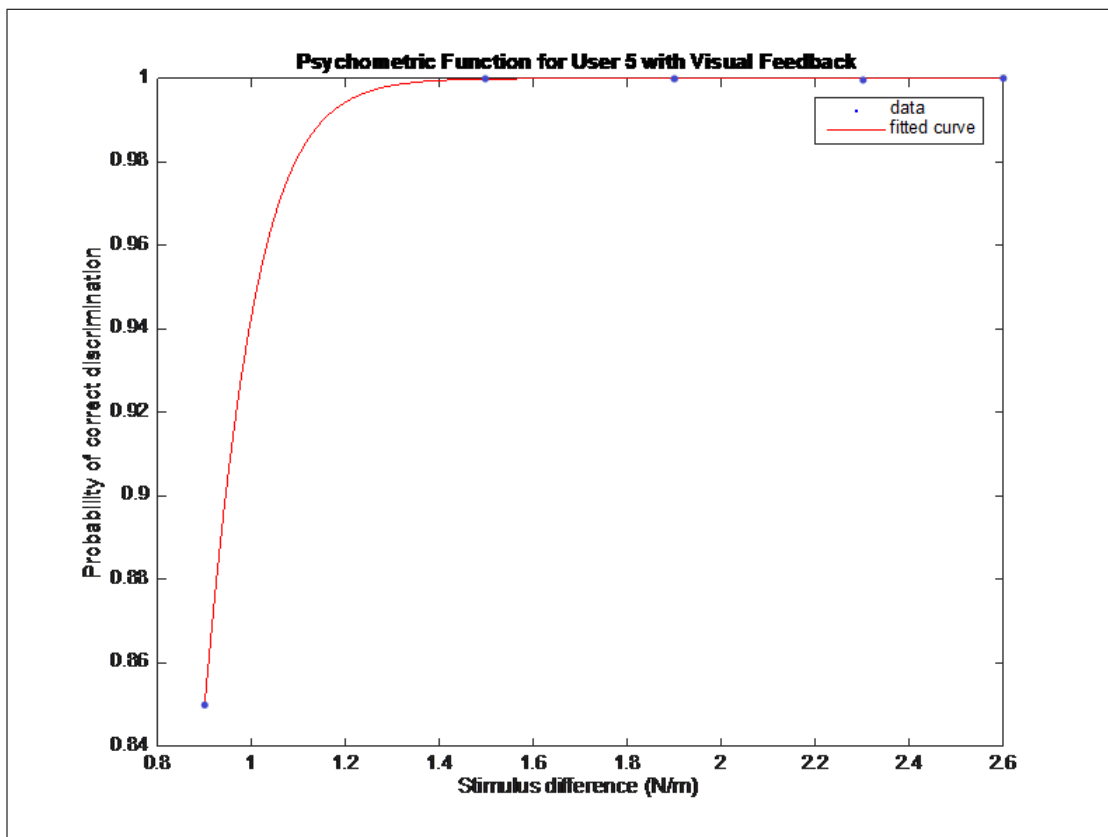

Figure 4.17 Psychometric Function for User 5 with Visual Feedback.

Figure 4.18 shows the psychometric curve of User 6 for the 2-AFC task with visual feedback. The discrimination threshold for User 6 could not be determined in these trials because no trend that showed better discrimination as Δk decreased was observed. Thus, curve fitting to Eq. 3.7 could not be performed.

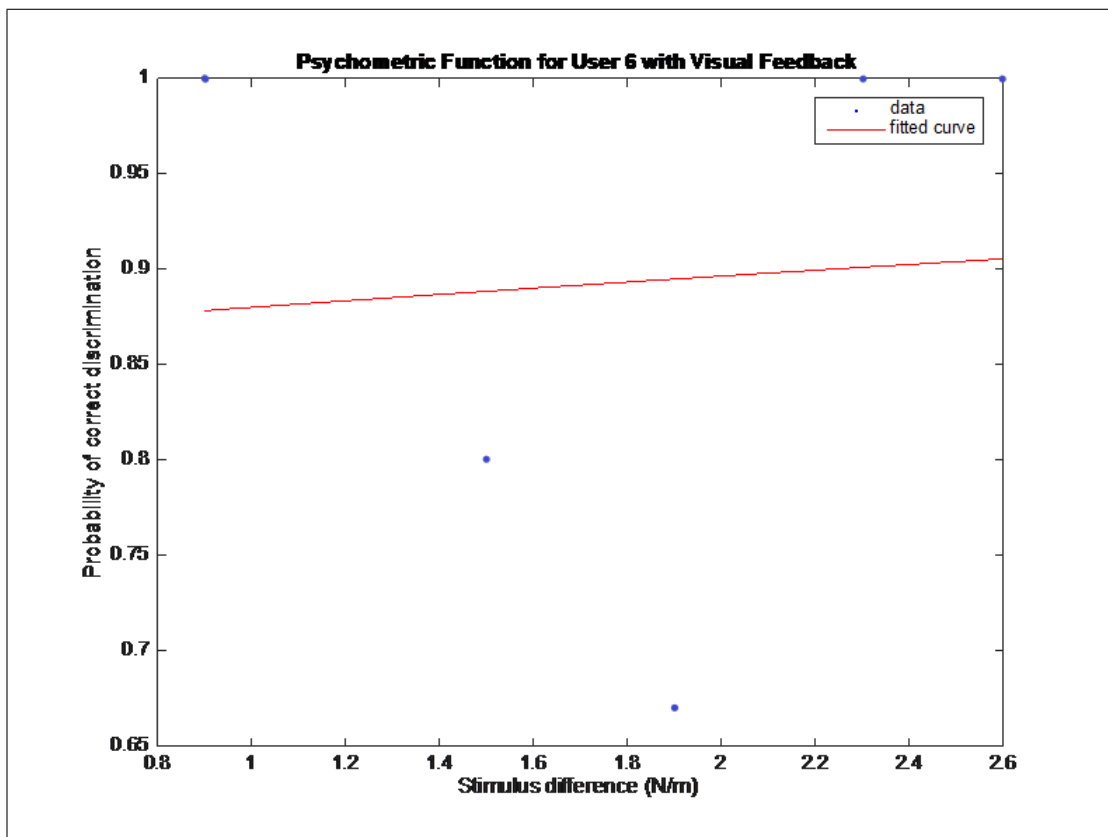

Figure 4.18 Psychometric Function for User 6 with Visual Feedback.

Table 4.3 shows a summary of discrimination thresholds found in the experiment with visual feedback.

Table 4.3
Discrimination threshold of each experiment with visual feedback.

User	Discrimination Threshold (N/m)
User 1	Could not be determined
User 2	0.98
User 3	0.95
User 4	Could not be determined
User 5	Could not be determined
User 6	Could not be determined

5. DISCUSSION

The aim of this thesis was to design a virtual environment to perform psychophysical tasks to discriminate between objects of various stiffnesses. Then we attempted to demonstrate that the virtual environment was functional in facilitating psychophysical trials by designing a discrimination task to distinguish between cubes of differing rigidity against a control cube.

As described above, the virtual environment was designed using the Gazebo simulation software, and a probe is used to generate the force on the object. The object then moves according to the mass-spring-damper model, which is used to model the deformation of the object. The distance the object moves and a sound generated from the simulation environment based on this movement is used as visual and audio feedback for the subject to distinguish between the relative stiffness of various objects against a control object.

The 2-AFC trials performed as part of this thesis show that the virtual environment works to design and implement psychophysical experiments to discriminate between the stiffness of objects presented to users with audio and visual feedback.

The results of the trials showed that the discrimination threshold varied widely among the subjects. Also, it was observed that in the trials with visual feedback, the subjects performed nearly all of the trials accurately. Since the subjects were able to discriminate the objects in most of the tasks, it was not possible to form the psychometric curve. The largest discrimination threshold was observed in the trials with audio feedback. In the trials where both audio Lecuona and Quesda show that in stiffness discrimination trials with multimodal feedback, audio feedback makes discrimination more difficult [23].

5.1 Comparison with other Stiffness Discrimination Environments

Argelaguet et al. show that pseudo-haptic feedback can be used to discriminate between objects in a virtual environment. In this trial, visual feedback is used to discriminate between objects in a collaborative scenario in which two users interact with a deformable object. In this trial, a virtual environment was used where the user was asked to push on alternating cubes to observe which one was stiffer based on visual feedback and then two users were asked to push on opposite ends of a cube to discriminate between the alternating cubes. The experiment design was similar to the one described in the paper, and the trials were performed successfully [5]. Figure 5.1 shows the virtual environment used in this study.

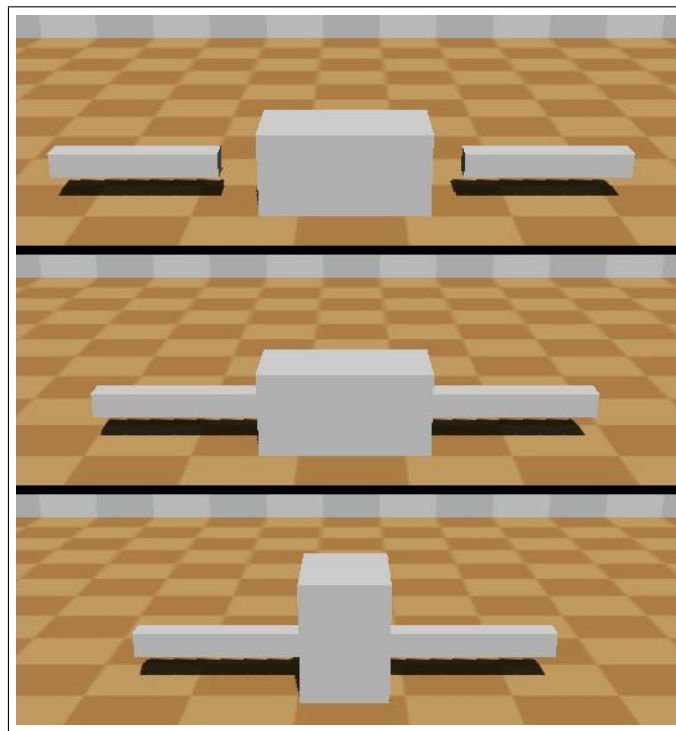

Figure 5.1 Depiction of virtual environment used in Argelaguet et al [5].

In contrast to the results in this thesis, the psychometric curve in Argelaguet et al.'s experiment with visual feedback was as expected and did not vary much when tests with one or two users. The reason for this may be that that in the case of

this environment the object is deformed and, in our environment, displacement of the objects is used to model deformation.

5.2 Limitations

The choice of the virtual environment, the Gazebo simulator, was based on the software being open source and compatible with multiple programming languages and other software. However, the simulator is Linux dependent, and we were unable to use the software with Microsoft Windows based software. Since the Lab's current software works on Microsoft Windows, we were not able to use the current setup for haptic feedback. Integrating the current setup with the virtual environment is a future aim to perform trials with vibrotactile feedback.

Also, the Gazebo environment was limited in terms of allowing for deformation of objects. Thus, we used the mass-spring-damper model described above. However, this made discriminating the stiffness of the object with visual feedback very easy for the user since the user could clearly see how the object moves. This can also be observed in the results of the trials, where each user performed nearly all of the tasks with visual feedback correctly.

5.3 Future Work

This research can be furthered by adding vibrotactile feedback trials to the experiments done. This will increase the scope of the virtual environment. In addition to uses in basic science, adapting the virtual environment to work with haptic feedback and wearable vibrotactile devices will provide information on tactile sensation in the finger or possibly other parts of the body. Neuroprosthetic and robotics applications can greatly benefit from a virtual environment which provides information and training space for tactile sensation. Also, the addition of a probe which the subject can control

could increase the range of psychophysical experiment types that can be done with the virtual environment.

Maereg et al. describe a wearable vibrotactile haptic device for stiffness perception, which is an example of some future work that can be done with the virtual environment described in this thesis. Maereg et al. use a virtual environment formed in the Unity 3D simulation engine and the Oculus Rift Head Mount Display. The virtual environment is used to compare the discrimination of stiffness on a virtual linear spring in three sensory modalities: visual feedback, tactile feedback, and their combination [24]. Figure 5.2 shows the virtual environment design, which can also be done using the virtual environment described in this thesis.

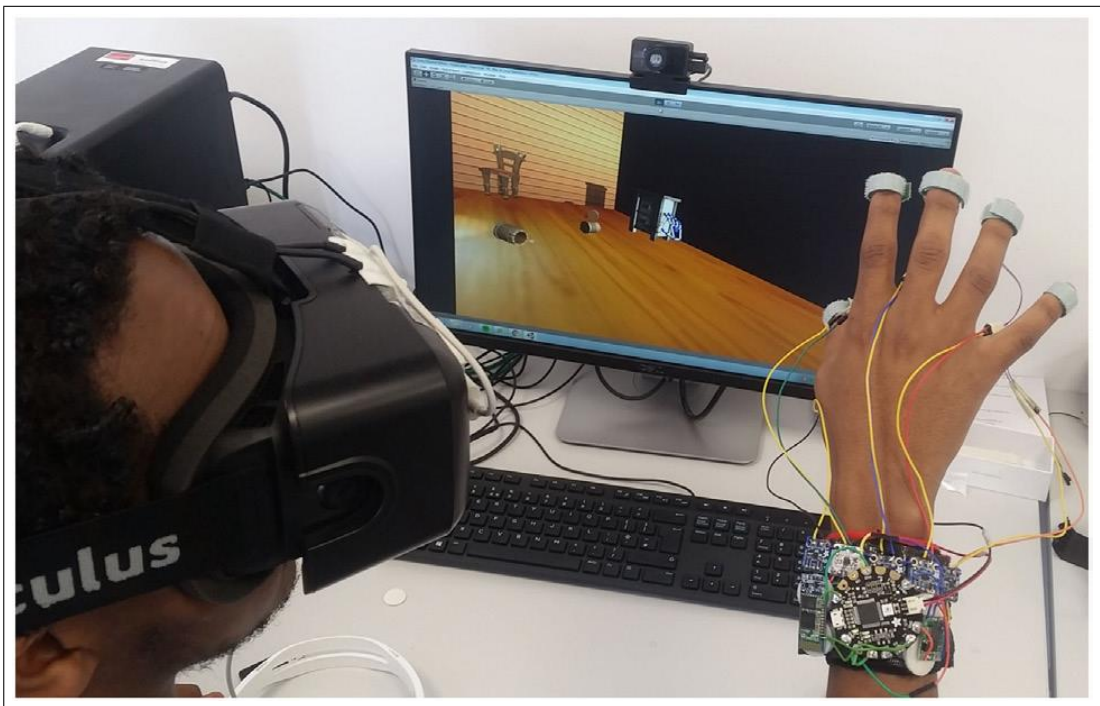

Figure 5.2 Depiction of virtual environment used in Argelaguet et al [5].

6. CONCLUSION

This thesis describes a virtual environment to perform psychophysical trials for stiffness discrimination using audio and visual feedback. The virtual environment was designed using the Gazebo simulation environment. The psychophysical trials show that the virtual environment can be used to determine the psychometric curve and discrimination threshold of the user's ability to discriminate between objects of different stiffnesses based on visual and/or audio feedback.

In conclusion, this virtual environment can be used in stiffness discrimination tasks. The audio and visual feedback modalities can be supplemented with vibrotactile feedback to determining grasping properties for neuroprosthetics and robotic arms.

REFERENCES

1. Jonas, L., “Royal holloway, university of london, department of psychology, advanced research methods course, lecture 9: Psychophysics, psychophysical methods, and signal detection theory notes,” 2014.
2. Montag, E. D., “Notes of lectures 4 and 5 from vision and psychophysics course at rochester institute of technology, center for imaging sciences.”
3. Mihelj, M., and J. Podobnik, *Haptics for Virtual Reality and Teleoperation*, Vol. 67, Springer Science & Business, 2012.
4. Trumper, D., “Mit opencourseware modeling dynamic and control lectures,” 2005. accessed: July 20, 2019 <https://ocw.mit.edu/courses/mechanical-engineering/2-003-modeling-dynamics-and-control-i-spring-2005/readings/>.
5. Argelaguet, F., T. Sato, T. Duval, Y. Kitamura, and A. Lecuyer, “Collaborative pseudo-haptics: Two-user stiffness discrimination based on visual feedback,” (Heidelberg, Berlin), pp. 49–54, International Conference on Human Haptic Sensing and Touch Enabled Computer Applications, Springer, 2014.
6. Borton, D., S. Micera, J. D. R. Millán, and G. Courtine, “Personalized neuroprosthetics,” *Science Translational Medicine*, Vol. 5, no. 210, 2013.
7. Stefano, G., “Robotic surgery: Fast forward to telemedicine,” *International Medical Journal of Experimental and Clinical Research*, Vol. 23, p. 1856, 2017.
8. Unger, B., *Psychophysics of Virtual Texture Perception*. PhD thesis, Carnegie Mellon University, Pittsburgh, Pennsylvania, 2008.
9. Bensmaia, S., M. Hollins, and J. Yau, “Vibrotactile intensity and frequency information in the pacinian system: A psychophysical model,” *Perception and Psychophysics*, Vol. 5, no. 67, pp. 828–841, 2005.
10. Wichmann, A. F., and N. J. Hill, “The psychometric function: I. fitting, sampling, and goodness of fit,” *Perception and Psychophysics*, Vol. 63.8, pp. 1293–1313, 2001.
11. Wichmann, F., and F. Jäkel, “Methods in psychophysics. stevens’ handbook of experimental psychology and cognitive neuroscience,” *Methods in Psychophysics*, Vol. 5, pp. 1–42, 2018.
12. Baird, J. C., and E. Noma, *Fundamentals of Scaling and Psychophysics, chapter 1*, John Wiley Sons, 1978.
13. Fechner, G. T., *Elemente der Psychophysik (2nd ed.)*, Vol. 2, Leipzig, Germany: Breitkopf Härtel, 1889.
14. Gescheider, G., *Psychophysics: The Fundamentals*, Mahwah, New Jersey: Lawrence Erlbaum Associates, 1997.
15. Schiffman, H., *Handbook of Research Methods in Experimental Psychology*, ch. 20, Psychophysics, pp. 441–469. Blackwell Publishing Ltd, 2003.
16. Cornsweet, T., “The staircase-method in psychophysics,” *The American Journal of Psychology*, Vol. 75, pp. 485–491, 1962.

17. A. Ehrenstein, and W. H. Ehrenstein, "Psychophysical methods," in *Modern Techniques in Neuroscience Research*, Berlin, Heidelberg: Springer, 1999.
18. García-Pérez, M., and R. Alcalá-Quintana, "Improving the estimation of psychometric functions in 2afc discrimination tasks," *Frontiers in Psychology*, Vol. 2, p. 96, 2011.
19. Angelo, J., "The link flight trainer: A historic mechanical engineering landmark, roberson museum and science center," (Binghamton, New York), ASME, 2000.
20. Virtual Reality Society, "History of virtual reality." Accessed July 20, 2019 <https://www.vrs.org.uk/virtual-reality/history.html>.
21. Veron, H., P. Hezel, and D. Southard, "Head-mounted displays for virtual reality." helmet- and head-mounted displays and symbology design requirements," *International Society for Optics and Photonics*, Vol. 2218, pp. 41–50, 1994.
22. Open Source Robotics Foundation, "Gazebo robotics simulator." accessed: July 20, 2019 <http://www.gazebo.org/>.
23. Reyes-Lecuona, A., and F. J. Cañadas-Quesada, *Engineering the User Interface: From Research to Practice*, ch. Interference of auditory information with haptic perception of stiffness in virtual reality, pp. 1–12. London, UK: Springer, 2008.
24. Maereg, A. T., A. Nagar, D. Reid, and E. L. Secco, "Wearable vibrotactile haptic device for stiffness discrimination during virtual interactions," *Frontiers in Robotics and AI*, Vol. 4, no. 42, 2016.