

FOR REFERENCE

A COMPUTER AIDED BIOFEEDBACK SYSTEM

NOT TO BE TAKEN FROM THE LIBRARY

by

I. MELIH AYBEY

B.S. in E.E., Bogazici University, 1983

Submitted to the Biomedical Engineering Institute

in partial fulfillment of the requirements for

the degree of

Master of Science

in

Biomedical Engineering

Bogazici University Library



39001100313454

14

Bogazici University

1986

# TABLE OF CONTENTS

## ABSTRACT

## TURKCE OZET

### I. INTRODUCTION

1.1 Purpose of this thesis .....	1
1.2 Definition of biofeedback .....	2

### II. THEORY

2.1 Basic Principles .....	3
2.2 Homeostatic Adaptive Control Systems .....	4
2.3 Control of input .....	6
2.4 Homeostasis in health and disease .....	11
2.5 Biofeedback and Homeostasis .....	12
2.6 Concept of Biofeedback .....	13
2.7 Biofeedback as a therapeutic method .....	15
2.8 Basic elements of treatment .....	16

### III. METHODS USED IN BIOFEEDBACK

3.1 Relaxation Session .....	19
3.2 Relaxation Training .....	19
3.3 Simple concentration .....	20
3.4 Alpha feedback .....	21
3.5 Mental imaginary .....	22

197685

3.6	Theta feedback .....	23
IV. SUMMARY OF BIOFEEDBACK TREATMENTS		
4.1	Treatment for tension headaches .....	25
4.2	Treatment for migraine headaches .....	34
4.3	Treatment for Raynaud's Disease .....	37
4.4	Treatment for asthma .....	41
4.5	Treatment for epilepsy .....	43
V. BIOFEEDBACK INSTRUMENTATION		
5.1	EMG feedback .....	51
5.2	Skin temperature feedback .....	54
5.3	EEG feedback .....	56
5.4	Heart rate and heart rhythms .....	59
5.5	Blood pressure .....	60
VI. BIOFEEDBACK EQUIPMENTS		
6.1	EMG feedback equipment .....	61
6.2	Temperature feedback equipment .....	63
6.3	GSR feedback equipment .....	64
6.4	EEG feedback equipment .....	65
VII. DIGITAL BIOFEEDBACK MONITOR		
7.1	Description of the system .....	68
7.2	Hardware .....	69

7.3 Machine code and Basic programs ..... 72  
7.4 User's manual ..... 74

VIII.DISCUSSION AND CONCLUSION ..... 78

APPENDIX A (ABBREVIATIONS)

APPENDIX B (FIGURES)

APPENDIX C (COMMERCIAL BIOFEEDBACK INSTRUMENTS)

REFERENCES

## ABSTRACT

Biofeedback is a psychological and medical therapy. It is used nearly in the entire range of human emotional and physical disorders. Its main difference from other methods is that the therapeutic process takes place in the mind-brain of the patient. The therapist and biofeedback machines only give him the right information and assist him. The patient is no longer the object of the treatment, he is treatment.

Biofeedback devices, unlike other medical devices, are not used in order to monitor a disordered physiological function. They are aimed to be used in training work to gain control over any physiological variable which may have no direct relation with the symptoms of the illness.

This thesis reviews the theory and applications of biofeedback and presents an original design of a computerized biofeedback system (DBM). The digital biofeedback monitor is a system which enables the therapist to analyse the data obtained during and after a biofeedback session by means of a digital computer. It can also be used by the patient for any kind of biofeedback treatment. Collected data related to the session can be stored onto a floppy disc for future references and analyses.

## Ö Z E T

Biyolojik geri besleme (biofeedback) psikolojik ve tıbbi bir tedavi şeklidir. insanın hemen hemen tüm ruhsal ve bedensel düzensizliklerinde kullanılabilen bu yöntem ile diğerleri arasındaki en önemli fark, burada tedavi sürecinin, hastanın beyin düşünme bölümünde gerçekleşmesidir. Terapist ile biyolojik geri besleme cihazları hastaya sadece doğru bilgi vermekte ve ona yardımcı olmaktadır. Söz konusu olan, artık bir hastaya terapist tarafından bir tedavinin uygulanması olmayıp hastada kendiliğinden bir sürecin gelişmesidir.

Biyolojik geri beslemede kullanılan cihazlar diğer tıbbi cihazların aksine, düzeni bozulmuş fizyolojik fonksiyonların izlenmesi değildir. Bu cihazların, hastalığa ait semptomlar ile doğrudan ilişkisi bulunmayabilen herhangi bir fizyolojik değişken üzerinde kontrol sağlama yeteneğinin geliştirilmesine yönelik olarak yürütülen eğitim çalışmalarında kullanılmaları amaçlanmaktadır.

Bu tez, biyolojik geri beslemenin teorisini ve uygulamalarını inceleyip bilgisayarlı bir biyolojik geri besleme sisteminin (DBM) orjinal tasarımını sunar.

Dijital biofeedback monitorü, terapistin biyolojik geri besleme seansında elde edilen verileri, bir dijital bilgisayarla anında ve daha sonra analiz edebilmesini sağlayan bir sistemdir. Ayrıca hasta tarafından da herhangi bir biofeedback tedavisi uygulaması amacıyla kullanılabilir. Seans ile ilgili toplanan veriler bir disket üzerinde saklanmak sureti ile ilerideki analiz ve başvurularda kullanılabilirler.

## I. INTRODUCTION

### 1.1 THE PURPOSE OF THIS THESIS

This thesis can be divided into two main parts. In the first part the theme BIOFEEDBACK is worked out. This part is purposed to be a detailed documentation for anyone who wants to learn the theoretical backgrounds of the biofeedback concept, current methods used in biofeedback, reports of the past biofeedback treatments, biofeedback instrumentation or specification of biofeedback equipments.

In an ordinary biofeedback application the level of the physiological variable is transmitted only to the patient and the physician has a knowledge about the session based on the patient's reports. In case the physician wants to observe the session closer, then he may disturb the patient and therefore change the environmental conditions of the patient.

The second part of the thesis is a project which can enable the physician to observe the session as well as save the data obtained during training and analyse it by means of a digital computer again and again for any reason. A thin cable connecting the biofeedback equipment to the computer unit, which may be located in another room, is sufficient to transfer the data related to the physiological variable to the computer. So the physician can observe the session simultaneously, add the patient's psychological state and environmental changes to this observations, and use

it to instruct the patient on how to go on the session. Obtained data can be stored on a floppy disc for future use. The physician can analyse past sessions of a patient to see the change in his performance.

## 1.2 DEFINITION OF BIOFEEDBACK

Biofeedback is the process of instrumentally monitoring and communicating internal bodily functions with the goal of developing a useful degree of conscious patient control over these functions. It is a technique widely accepted in such fields as psychiatry, psychology, neurology, physical medicine, occupational and physical therapy and speech pathology.

Introduction

## II. THEORY

### 2.1 BASIC PRINCIPLES

Biofeedback is the process or technique of learning voluntary control over automatic, reflex regulated bodily functions. The functions under training are either autogenic or failed due to trauma or disease.

The basic idea in biofeedback applications is to provide subjects or patients some information about what is going on inside their bodies. This is the only chance for the subject to influence the process. The foundation of biofeedback is related to two principles :

1-The principle of feedback : A sample of output is added to the system as input in a way to influence the output. Biofeedback is a special case of it related to biological systems.

2-Great truism of information theory : It says that a variable cannot be controlled unless information about the variable is available to the controller. [3]

In biofeedback the variable to be controlled belongs to the controller. Supplying information about its state to the controller closes the feedback loop. The word 'biofeedback' is likely to express the feedback systems in biological organisms, namely in living organisms, though it only deals with external psychophysiological feedback which is not naturally present.

Theory

In biofeedback applications usually a very complex signal related to the internal variable is processed into a very simple information which is supplied to the subject. The resulting signal may be analog or digital and audio or visual modality is used as the feedback path.

Each cell in the body contributes, in its own way, to the survival of the total organism by helping to maintain the stable conditions for life. The concept of the maintenance of stable internal environment was worked by W. B. Cannon, American physiologist, who used the name homeostasis to denote these carefully coordinated physiological processes. [9]

## 2.2 HOMEOSTATIC ADAPTIVE CONTROL SYSTEMS (HACS)

The purpose of all psychological and physiological mechanisms is the survival of the organism or of its own kind by means of homeostatic adaptive control systems. Essential psychophysiological variables are kept within critical limits by HACS using feedback control. A block diagram representation of the components of HACS is shown in Figure T-1.

State and Transformation of HACS : The state of HACS depends on the values of variables in the boxes plus the information just received at their input. A knowledge of the state of HACS and new inputs is enough to identify the new state. The behaviour of an organism is the result of a chain of psychophysiological states with the changes between states being represented

by transformations. Any specific state may be defined by the process of designating the values of the information in the arrows representing information channels between the boxes.

#### The Components of HACS:

1) Environmental influences ( Channel 1 ): Everything which is outside the organism and has an effect on the organism is in this group. It may in the form of energy or information. The purpose of exteroceptive sensory systems is to convey this information.

2) Sensory input channel ( Channel A ): This channel conveys information from external environment to the different sensors which are the members of the Central Nervous System.

3) Sensory input feedback channels ( Channels B and B' ): Although exteroceptive sensory systems play the role of a transducer, the Central Nervous System and the Muscular System can influence this system. By using feedback paths B and B' they can control sensory input to change the capacity to focus attention selectively from one sensory modality to another and to attend selectively within a particular part of the environment.

4) Muscle effector channel ( Channel C ): This channel carries the commands of the brain to the muscular system.

5) Feedback to the environment and effector to the environment ( Channel 2 ): After the transformation of commands of the brain by the muscular system into muscular action they are given to the environment either as information ( eg. in speech and gesture) or as energy (eg. in moving an

object). The only output mechanism of the brain to the environment is by activation of the muscular system.

6) Muscle feedback channel ( Channel D ): Channels for the feedback of muscle performance exist in proprioceptive fibers in muscle, as well as in other interoceptive and exteroceptive receptors which reflect what the muscle has done.

7) Autonomic effector channel ( Channel E ): Autonomic control channels are responsible for central control of autonomic functions ( eg. heart rate, skin temperature, tear secretion, etc. ) such that the regulation of these functions is possible. There are two systems associated with autonomic control channels: sympathetic and parasympathetic systems. As a result there are usually two associated channels to control a specific organ.

8) Interoceptive and autonomic feedback channel ( Channel F ): This channel carries information from visceral functions to the Central Nervous System. Evidences from autogenic training, yogic training and operand studies make it clear that these channels do not impinge upon consciousness due to a lack of discriminative learning. [3]

9) Central nervous system information flow channels ( Channels G,H ): Central processor in CNS calls cognitive and memory functions by using channel H. Channel G is the response of memory and cognitive units to the command transmitted by channel H. It consists of the elicited cognitive and mnemonic material presented for central processing and is associated with consciousness of thought or memory.

## 2.3 CONTROL OF INPUT

### Theory

In 1963 Ashby showed experimentally that a system can be brought to the desired state by controlling the input over a sequence of particular steps which consist of several states and transformations regardless of the beginning state. Therefore the control of the information channels which are the input parameters to a particular component is the main mechanism in control of state.

1) Control of sensory input (Channel 1 and A): Any decrease in the level of input signal to the exteroceptive sensory systems directly causes a reduction in output of these sensors. The function of exteroceptive sensory systems can be inhibited by using a foreign substance, usually a drug. Control of these systems can also be exerted by sensory overload where all modalities are maximally stimulated.

2) Control of sensory feedback (Channel B): Channel B is the feedback path from the Central Processor to the sensory systems. It is used to control the sensory systems. For example, concentrating the eye on a particular point of the visual world can be achieved by a feedback mechanism between the eye and the Central Processor.

3) Control muscle tension (Channel C): The commands of the brain to the muscular system is transmitted through Channel C. The quantity of information increases during complex motor tasks and always a high degree of organisation is present. Relaxation refers to the state where most of the muscle fibers are inactive which is a result of diminished signal flow through Channel C. Murphy and Leeds (1975) showed that for some individuals

before relaxation the memory was not accessible to consciousness and after relaxation a physiological reorganisation took place. It has also been showed that anxiety cannot exist in the presence of deep muscle relaxation. As a result, reduced stress level can be achieved simply by reducing muscle tension. Sleep is the only psychophysiological state with its own unique organisation where complete muscle relaxation occurs. [3]

4) Control of Muscle Feedback ( Channel D ): In order to control muscle tension a knowledge about the state of the muscle is necessary. Therefore for controlling muscle tension, monitoring of proprioceptive feedback from the muscular system is used. Jacopson showed that muscle tension cannot be controlled by humans since he is unable to recognize it. The method for muscle relaxation training utilizes discriminative learning of the recognition of muscle tension level.

5) Control of autonomic variables and control of interoceptive and autonomic feedback ( Channels E and F ): The control mechanisms of autonomic variables which are relatively automatic and involuntary consist of closed feedback loops which are normally not accessible by consciousness without discriminative training. Yogic training showed its power in controlling these variables. Trained yogis can control heart rate, skin temperature, etc.

6) Control of cognitive and mnemonic variables and the control of their feedback ( Channels G and H ): The observation of these variables is possible only through introspective consciousness. Muscular and sensory systems influence cognitive and mnemonic functions to a high degree. Unless the motor and sensory activities are lowered, the interference of cognitive

and mnemonic functions with these activities occurs.

7) Control of state through complex control information channels: In every specific state the specification of the information on all of the channels is different. Arousal level is the state where an average activity in all channels is observed. In high arousal state many channels are active whereas in low arousal level a few channels have important activity.

8) Yogic Asanas (postures): In typical application of yogic asana a specific muscle group is activated. First step is to stretch the muscle. As a result the feedback mechanism through channel D is activated and also processed by the Central Processor which results in the activation of the muscle fibers in the same group by means of reflex mechanism through channel C. So the asana has an alerting effect.

9) Yogic or Zen meditation: Meditation can be used to put the sensory system into a state of relative deprivation and stereotype. This can be achieved in a quiet and calm environment by using sensory feedback control. Cognitive and mnemonic functions are consciously controlled by voluntarily limiting the content of the thought.

10) Yogic autonomic Control: In case the preconditions above are fulfilled, then it may be possible to focus the attention consciously upon a specific autonomic function and so to gain control of it provided that the person is trained in an appropriate way.

11) Free associative state: It can be seen that any particular mental state can be defined by stating the contents of every information channel. Free associative state is defined as the state of free ready availability of floating thought and memory, namely channels G and H. However

it is obvious that this can not be achieved unless first the muscular and sensory systems are controlled.

12) Control of state through biofeedback: Biofeedback gives to the organism the chance to gain control of the state by means of establishing an external channel to the organism to provide information about a particular psychophysiological variable which is wanted to be taken under control.

Theory

## 2.4 HOMEOSTASIS IN HEALTH AND DISEASE

Homeostatic control systems are responsible for the balance of physiological variables inside the organism. When any variable leaves its normal range then it results in some disordered physiological or psychological functions which can be denoted as disease condition. However, the cause of disease is not defined by the effects of disease and usually correction of the effect by any means does not cure the disease since, as in most cases, it may be secondary effect of the deranged physiological variable.

It has been shown that external environment can influence the organism. [3]. So external environmental stress can stimulate the organism in such a way as to lead a change of the values of various homeostatically mediated physiological parameters beyond their normal limits. If the stress becomes chronic, then the homeostatic mechanism can reset itself at the new, abnormal value and remain there even after the stress is removed. Investigations of the cases in peptic ulcer, arthritis, hypertension, diabetes, migraine, and tension headaches resulted in recognition of stress as a pre-condition for the emergence of the disease.

In 1967 Holmes and Rahe carried out an investigation about the correlation of the major life events and incidence of illness. They found out that the incidence of illness during important times for the person such as marriage or death of a friend, regardless of the degree of happiness, increases compared to times when individuals live relatively more quiet.

## 2.5 BIOFEEDBACK AND HOMEOSTASIS

Biofeedback adds an extra external feedback loop to the present feedback loops of the organism which are parts of the Homeostatic Adaptive Control System. The diagram in Fig. T-2 indicates the information channels added due to biofeedback.

Channel 1 is the information flow channel from the Central Nervous System to the exteroceptive sensory systems. A typical application of this channel is the alpha feedback.

Channel 2 conveys information from the muscular system. EMG is a typical application of this channel.

Channel 3 is the information flow channel between exteroceptive systems and autonomic systems. Heart Rate and Skin Temperature Feedback are examples for application of this channel.

Biofeedback adds an extra external feedback loop to the present feedback loops of the organism which are parts of the Homeostatic Adaptive Control System. The diagram in Fig. T-2 indicates the information channels of HACS and added channels due to biofeedback.

The biofeedback process is highly dependent upon the kinds, quality and

accuracy of the information provided. The kinds of information are:

- 1) Biofeedback information which is the biofeedback signal,
- 2) Cognitively useful information which is background information that facilitates the use of biological information. This can be what the physiological activity does, how it behaves, how it is measured, what the instrument does, etc.
- 3) Strategy information such as clues or directions for changing physiologic activity by mental means,
- 4) Physiologically supporting information which is encouragement and reinforcement of performance that supports the learning experience,
- 5) Experiential information which is the internally desired information from memories and from associations of the newly perceived information from the biofeedback signal with internally perceived changes in mind and body states.

If all of these informations are accurate enough then the necessary pre-condition of biofeedback learning process is fulfilled. Therefore in biofeedback learning process and leaning to control biological activities the teacher must have access to the relevant information and the teacher must provide the information.

## 2.6 CONCEPTS OF BIOFEEDBACK

The major concepts concerned in biofeedback are :

- 1) Conditioning as biofeedback: The main work about biofeedback was

Theory

developed from operand conditioning theory which says that behaviour and learning result from appropriate rewarding of innate biological activities for performance. In biofeedback application a biofeedback monitor is used as a reward for correct performance.

2) Stress reduction as biofeedback: Biofeedback is used in reduction of tension and anxiety. The success of the stress reduction approach lies in the clinical effectiveness of a wide variety of relaxation therapies and research. The basis of the relaxation effect is the development of awareness on the discrimination of the feeling of relaxation, and the discrimination of fine differences between different levels of tension and relaxation. In this approach, the biofeedback information is used by the patient to facilitate his discrimination between tension levels, and procedurally, the technique may employ a variety of biofeedback signals.

3) Biofeedback as a cognitive mechanism: In the successful application of biofeedback two observable quantifiable events can be identified; the conceptual information of biofeedback procedure, ie, the instructions, the attitudes and physiological biofeedback information, and second, the result, which is learned, voluntary control over the selected physiological function. When the information reaching the brain is integrated, evaluated, put into memory, and the product of this brain activity is used to activate patterns of neural activity. As a result, discrete, channelled directions to control the selected physiological activity is achieved.

The results of studies on availability and the accuracy of the information about the process proved their role on the possibility of the control of

physiological functions. It can be said that an internal, presumably a cerebral, information-processing system is capable of discriminating productively useful information and activating physiological mechanisms to achieve specific, directed changes in physiological activity.

The concept of higher mental activity as the controller and normalizer of all physiologic systems can be viewed as an extension and definition of the stress reduction concept. By postulating a cerebral control system operating specifically to appreciate, to integrate and to direct biological activities, one can account for the influence of the numerous cognitive aspects of biofeedback procedures which appear to contribute to the widespread effectiveness of biofeedback in an extraordinary number of disorders.

## 2.7 BIOFEEDBACK AS A THERAPEUTIC METHOD

As an important point in the application of biofeedback is the assumption that self-control can reduce the symptoms of the illness, regardless of the reason why the illness occurred in the first place.

Behavioral medicine has emphasized the importance of having the patient actively participate in the treatment program. Biofeedback is a type of behavioral medicine: first, the problems it treats are medical ones, second, the patient is an important component in the treatment. The therapist can

tell the patient how to use the feedback equipment, but only the patient can actually produce the desired changes through compliance with the instructions and regular practice. Self control means that the patient has the capacity to alleviate symptoms through his or her own behaviour, and this independence is clearly a major advantage of this type of treatment.

## 2.8 BASIC ELEMENTS OF TREATMENT

The basic steps in treatment are :

- 1-Evaluation session
- 2-Baseline session
- 3-Goal setting session
- 4-Treatment session
- 5-Terminal treatment session
- 6-Follow up

1) Evaluation session: In this session the present problem is reviewed and discussed, the patient's past medical history is taken, and the permission is obtained to review past treatment with primary physicians and others consulted. A tentative decision may be made to undertake treatment and how it might be relevant to his present problem. The next session is explained to the patient and an appointment for the next session is made.

2) Baseline session: The patient is introduced to the treatment room, physiological measurement transducers are put on, about five minutes of resting baseline measurements are collected, and then measurements are made

while a relaxation exercise is presented, usually from a tape recording. Depending upon the complexity of the instrumentation, the physiological measurements may either be evaluated by the therapist at the time if simple or evaluated later if complex. After finishing the baseline measurement, the transducers are removed and the patient is given complete instructions in carrying out the home practice relaxation procedure with a cassette tape recording.

3) Goal setting session: The session begins with a discussion of the experience with the home practice exercises. After this has been satisfactorily dealt with, the therapist will present some general observations about the baseline session and indicate a tentative biofeedback parameter with which to work. Possible physiological and symptomatic goals are presented to the patient and discussed. After agreement is reached, these goals are noted by both for future reference in judging progress. Usually there is time then for the patient to have the appropriate transducer applied and to practice with the biofeedback parameter for the remainder of the session. Before leaving, the home practice assignment is reviewed.

4) Training session: Following the goal setting session, the patient enters into a series of sessions which begin with the discussion of the progress in home practice and of self observation of symptoms. The transducers are applied and the patient begins the practice work with the biofeedback parameter, which is usually carried on during much of the rest of the sessions.

5) Termination: When it becomes evident that the treatment goals are

reached and that symptoms are satisfactorily managed, the topic of termination can be introduced into the dialogue. This is usually at least two or three sessions before the last one planned. The patient's reactions to this are noted and responded to as indicated and when the time arrives treatment is terminated.

6) Treatment follow-up: Questionnaires can be routinely sent after periods following treatment or routine follow-up visits can be scheduled.

Theory

### III. METHODS USED IN BIOFEEDBACK

#### 3.1 RELAXATION SESSION

In a relaxation session the patient must feel himself comfortable. The two major principles to follow are that the body parts are as comfortable as possible and in a position where further relaxation will not cause them to fall by the force of gravity. To achieve comfort the hands should be loosely open, the legs uncrossed and the clothing not binding. The head and neck present particular problems because they are positioned by the unconscious and almost involuntary gravitational neck muscle reflexes and because they are often involved in the pathophysiology of stress related syndromes.

Once the subject has gotten comfortable, he may be asked to close his eyes, listen to the instructor's voice or tape, and let his mind go to the parts of the body to which the instruction refers. Then the exercise may be read in a clear, calm, slow voice. While the exercise is being read the therapist should carefully observe the subject to notice particular reactions to the exercise.

After the session has been terminated the patient is asked to leave his relaxed state and after a time to get up and walk in order to prevent him to stay in a state which is too relaxed for him.

#### 3.2 RELAXATION TRAINING

Methods

The main difference between relaxation training and relaxation session is that relaxation training depends on an end-point achievement. In this case the role and the responsibilities of both the patient and the therapist are different.

Relaxation training is similar to various forms of meditation, such as transcendental meditation, Zen meditation, Yogic meditation, and other types. Also it is not hard to recognize the similarity of all of these techniques to mild, self-limited hypnosis. The major difference between these techniques and relaxation training is the ease of learning both for the therapist and patients. This is also supported by use of a tape recorder and by elimination of all but the simplest instructions.

The patient must agree to practice the relaxation procedure twice a day (tape listening). The patient must tell the home practice as detailed as possible to the therapist.

### 3.3 SIMPLE CONCENTRATION

In some cases, ie an unusually nervous patient, tape listening is not enough to relax the patient. For such a patient the best course may be to interrupt the home practice with the tape temporarily and ask him to practice the elementary concentration exercise for a week or two.

In a typical elementary concentration exercise the patient is instructed to sit quietly in a comfortable chair three times a day. On each occasion he is to close his eyes and repeat the phrase "peaceful, one, peaceful, two, peaceful, three, ..." until he is interrupted by a distracting thought. Then he is to make how high he had been able to count and mark it down on a piece of paper for the therapist. This is then repeated two more times.

### 3.4 ALPHA FEEDBACK

It is the most widely used method of EEG feedback. Alpha feedback is used in the treatment of tension headaches, migraine, headaches, and general tension states. No matter what the mechanism of alpha production is, alpha training (as for that matter EMG or temperature training) is a method of inducing the patient to focus his attention upon an internal process. This is a universally used meditation technique- to focus attention upon a bodily process- and is well known for its effectiveness in teaching meditation.

Alpha training can be offered to most patients with most stress-related conditions for which EMG and finger temperature feedback have been used with about the same expectation of success if that patient's resting EEG frequency is within the range of 8-12 Hz.

It is important that alpha training sessions are carried out in a pleasant, quiet setting, without disturbances. The alpha training itself usually involves about 30 minutes of continuous work in a quiet room, with the task

being to keep the alpha tone as much of the time as possible and at as loud amplitude as possible.

### 3.5 MENTAL IMAGERY

Mental imagery can be thought of in one sense as pictures in the mind or ideas or it may be thought of more broadly as relating to one's cognitive functioning. It may be used as an adjunct to relaxation and as a tool to facilitate the biofeedback task.

Images can occur in all of the sensory modalities, but the usual is visual imagery. The capacity of imagery diminishes with increasing age.

Mental imagery can be useful adjunction to biofeedback therapy and to relaxation task. In biofeedback, the patient may be asked to develop an image of the aspect of physiology that is being fed back and imagine it changing in the desired way. Practically, measurements often show that a change is achieved. A typical EMG biofeedback application is an example for the case. When the frontalis muscle is instrumented and is resistant to change, such as may be the case in the early treatment session the patient can use imagery to visualise the muscle at its tense level and then manipulate the image to represent a change toward relaxation. The manipulation could be in the form of imaging something which represents tension following out of the muscle. If the image is successfully manipulated, usually there is an actual reduction in the amount of tension

### Methods

present in the muscle.

As an adjunct to the relaxation task, mental imagery can be employed to visualize passive and relaxing scenes and therefore bring about a lowering of tension or arousal for the time that the image is held in the mind's eye. Patients can be encouraged to visualize favorite scenes after a few approximate ones are suggested. Some scenes often suggested are a walk through the woods or a day out fishing, with elaborate attention to the detail that may be encountered with the experience being suggested. Guided imagery helps the patient to develop his own favorite passive scene that he will learn to visualize whenever he wishes to relax and avoid momentary tension. The scene should be passive and not contain other people. It is not necessary for the patient to tell the therapist about the scene he visualized.

### 3.6 THETA FEEDBACK

Theta waves are present in EEG records and have a frequency range of 6-9 Hz. In presence of this slow frequency theta waves the body, mind and emotions are quiet and the individual experiences an increasing imagery. Slow wave EEG biofeedback training is suggested as an aid to learning. But it is not used widely.

Theta feedback is similar to alpha feedback. The training goal will be based upon the patient's baseline measures of amplitude within the selected

### Methods

frequency bandwidth. The goal might include producing theta of an amplitude at least twice as great as that in the baseline measure and maintaining its production for at least half of the feedback period at 50 per cent of the time if one is using a per cent time analyser.

During theta training session the environmental conditions must be as in the case of alpha training and EEG electrodes are placed over the occipital region of the head on one side and the second reference electrode placed over a neutral side such as the earlobe that acts as a ground.

The theta training itself involves from 15 to 30 minutes of continuous work in a quiet room, with the task being to keep the theta tone on for as much of the time as possible. The training session may be once a week or as frequent as each day, but should be continued until at least 200 minutes of training time have accumulated.

Methods

#### IV. SUMMARY OF BIOFEEDBACK TREATMENTS

##### 4.1 TREATMENTS FOR TENSION HEADACHES

STUDY : Budzynski, Stoyva, Adler 1970

PATIENTS : Female, age 29; female, age 33; female, "middle-aged"; female, "young high school teacher"; male, "middle-aged"

BIOF. TREATMENT : Auditory feedback of frontal EMG during 30-min sessions, 2 or 3 times weekly for at least 5 weeks

OTHER TREATMENT : Daily home practise

##### \*\*RESULTS

SYMPTOMS : Average hourly headache activity, subjectively rated from 0 to 5, was reduced from a baseline average of .84 to .30 after the 4th week of training

BIO. FUNCTION : Average microvolt levels of EMG: baseline, 5.8; training week #1, 4.6; training week #2, 4.0; training week #3, 3.7; training week #4, 3.5

STUDY : Budzynski, Stoyva, Adler, Mullaney, 1973

PATIENTS : 2 males, 16 females; average age, 36; range, 22 to 44

BIOF. TREATMENT : Auditory feedback of frontal EMG during 30-min sessions, twice weekly for 9

OTHER TREATMENT : Home practice twice daily for 15 to 20 min

##### \*\*RESULTS

SYMPTOMS : Average hourly headache activity, subjectively rated from 0

Treatments

to 5, decreased from .5 during the baseline to .2 at the end of training to .1 at 3-month follow-up

BIO. FUNCTION : Average microvolt levels of EMG: baseline, 10; training, 3.9; 3-month follow-up, 3.9. Weekly headache activity was correlated (.90) with frontal EMG levels

STUDY : Chesney, Shelton, 1976

PATIENT : 22 females, 2 males

BIOF. TREATMENT : Auditory and visual feedback of frontal EMG during eight, 30-min feedback sessions twice weekly for 4 weeks

OTHER TREATMENT : None reported

**\*\*RESULTS**

SYMPTOMS : Average levels during first and fourth weeks: headache frequency, 4.8 and 2.8; duration, 5.3 and 6.3 hours; severity on a scale of 1 to 100, 52.3 and 32.5

BIO. FUNCTION : Data Unavailable

STUDY : Cox, Freundlich, Meyer, 1975

PATIENTS : 20 females, 7 males; age range: 16 to 64; symptom duration, 1 to 39 yrs; average age, 11

BIOF. TREATMENT : Auditory analogue feedback of frontal EMG during 30-min sessions twice weekly for four weeks

OTHER TREATMENT : Cue controlled breathing immediately following feedback and prior to each meal; relaxation as learned in feedback sessions twice daily; medication

Treatments

**\*\*RESULTS**

SYMPTOMS : Average levels during the baseline, 2-week follow-up, and 4-month follow-up: headache index, 1.7, .6, and .6; duration 95, 33, and 31; frequency, 18, .1, and 8; medication used, 34, 14, and 9; psychosomatic checklist scores, 32, 13, and 17

BIO. FUNCTION : Correlation between reductions in EMG and changes in headache activity: .42

STUDY : Diamond, Medina, Diamond-Falk, DeVeno, 1979

PATIENTS : 19 with muscle contraction headaches; 265 with combined muscle contraction and vascular headache

BIOF. TREATMENT : Auditory analogue feedback of frontal EMG for 10 min and finger temperature for 20 min, 2 to 10 times weekly for up to 4 weeks

OTHER TREATMENT : Relaxation exercises; home practice twice a day for up to 4 weeks

**\*\*RESULTS**

SYMPTOMS : Percent stating that biofeedback helped their headaches: muscle contraction alone, 72; combined muscle contraction and vascular headach, 73

BIO. FUNCTION : Data unavailable

STUDY : Epstein, Hersen, Hemphill, 1974

PATIENTS : Male, age 39; symptom duration, 16 years

BIOF. TREATMENT : Experiment one: auditory feedback of patient-selected music contingent upon reductions in frontal EMG during 24, 10-min sessions;

experiment two: 10-min auditory feedback and 10-min no-feedback segments in counter balanced order

OTHER TREATMENT : While an inpatient in hospital (Exp. 1) Sinequan 25 mg. q.i.d., Phenobarbital 1.5 mg/day, Dilantin 300 mg/day; While an outpatient (Exp. 2) a placebo was administered with home relaxation instructions

**\*\*RESULTS**

SYMPTOMS : Average in baseline #1, feedback #1, baseline #2, and feedback #2, in experiment one: headache intensity, 5.0, 3.5, 5.8, and 2.5; averages in baseline #1, feedback #1, and baseline #2 in experiment two: headache intensity, 6.2, 4.8, and 10.8; medication used, 3.2, 1.2, and 2.2; no headache was reported on 64 of 66 days during the follow-up

BIO. FUNCTION : Number of seconds per minute below criterion of 10 uV  
experiment one: baseline #1, 21; feedback #1, 37; baseline #2, 30; feedback #2, 45

STUDY : Epstein, Abel, 1977

PATIENTS : 2 males, 4 females; average age, 32.8

BIOF. TREATMENT : Feedback of frontal EMG during 16, 20-min sessions

OTHER TREATMENT : A 20-min "no-feedback" segment followed each feedback session

**\*\*RESULTS**

SYMPTOMS : Average hourly headache activity (rated 0-5): baseline, 2.2; treatment, 1.7; follow-up, 1.5

BIO. FUNCTION : Average uV level of frontal EMG: baseline, 19.4; feedback, 17.8; follow-up, 20.6

Treatments

STUDY : Feuerstien, Adams, Beiman, 1976  
PATIENTS : Female, age 67 with combined migraine and tension headache  
BIOF. TREATMENT : Feedback of frontal EMG for 20 min, once weekly for 6 weeks  
followed by feedback of cephalic vasomotor responses for 30 min, once weekly  
for 6 weeks  
OTHER TREATMENT : Home practice for 10 min, twice daily

\*\*RESULTS

SYMPTOMS : Average weekly headache frequency: baseline, 4.4; EMG  
feedback, 1.8; baseline, 3.3; CVMR feedback, 1.3; 8-week follow-up, 2.5;  
average intensity (rated 1 to 4): baseline, 2.8; EMG feedback, 1.5; baseline  
2.1; CVMR feedback, 2.6; 8-week follow-up, 1.3; average duration: baseline  
15.8; EMG feedback, 4.6; 8-week follow-up, 7.5; no headache reported for 3  
weeks during CVMR feedback; use of tranquilizers was reduced from 3 to 1  
during the study

BIO. FUNCTION : Frequency of vasospasm during baseline, feedback, and  
baseline of sessions 5 and 6: EMG feedback, 7.7, 5.3, and 2.9; CVMR feedback,  
.8, 1.1, and .4

STUDY : Freid, Lamberti, Sneed, 1977  
PATIENTS : 6 females; age range 31 to 47; 1 with tension headaches, 2  
with mixed tension and vascular headaches  
BIOF. TREATMENT : Home practice of skin temperature raising with a portable  
trainer twice daily  
OTHER TREATMENT : Autogenic phrases repeated twice daily for 2 weeks

preceding temperature training

**\*\*RESULTS**

SYMPTOMS : Number improved by more than 75%: 1 with tension headache, 1 with mixed tension and vascular headache; number improved very little or questionable: 1 with mixed tension and vascular headache

BIO. FUNCTION : Data unavailable

STUDY : Haynes, Griffin, Mooney, Parise, 1975

PATIENTS : 7 males, 14 females; average age 20.9; average symptom duration, 5.2 years

BIOF. TREATMENT : Feedback of frontal EMG during 20-min sessions, twice weekly for 3 weeks

OTHER TREATMENT : None reported

**\*\*RESULTS**

SYMPTOMS : Average levels during baseline, 1-week follow-up, and 5- to 7-month follow-up: frequency, 5.5, 1.5, and 1.2; intensity, 3.4, 1.7, and 4.1; duration, 4.7, 2.9, and 2.3; headache index, 82.1, 20.9, and 11.4

BIO. FUNCTION : Data unavailable

STUDY : Hutchings, Reinking, 1976

PATIENTS : 14 females, 4 males; average age, 23

BIOF. TREATMENT : Auditory analogue feedback of frontal EMG during 10, 15-min sessions

OTHER TREATMENT : Practice twice daily, especially when in "stress-producing situations"

Treatments

**\*\*RESULTS**

SYMPTOMS : By the end of a 28-day follow-up, 66% improved; composite headache scores (computed by multiplying the # of H.A. hours times the average intensity for that day) were reduced from 10 prior to treatment, to 6 during treatment, to 4 following treatment

BIO. FUNCTION : Average level of EMG in microvolts/min: 19 prior to treatment, 8 during treatment, 5 during the follow-up

STUDY : Kondo, Canter, 1977

PATIENTS : 18 females, 2 males; age range 19 to 38; symptom duration, 8 to 45 months

BIOF. TREATMENT : Auditory analogue feedback of frontal EMG during 20-min sessions every 1 or 2 days for 10 sessions

OTHER TREATMENT : None reported

**\*\*RESULTS**

SYMPTOMS : Average number of headaches decreased from approx. 5.3 during the 10 days preceding training to approx. 1.9 during training

BIO. FUNCTION : Average Mv levels of frontal EMG during the first and last 5 mins of session #1: 27 and 22; during session #10: 15 and 10

STUDY : McKenzie, Ehrisman, Montgomery, Barnes, 1974

PATIENTS : 6 females, 1 male; average age, 33; range, 28 to 42

BIOF. TREATMENT : Binary visual feedback of EEG activity twice weekly for 5 weeks

OTHER TREATMENT : None reported

Treatments

**\*\*RESULTS**

SYMPTOMS : Average number of headache hours per week: 41 before treatment, 8 during treatment, 7 at 1-month follow-up, 2 at 2-month follow-up  
BIO. FUNCTION : Data unavailable

STUDY : Philips, 1977b

PATIENTS : 15 with headaches at least twice weekly

BIOF. TREATMENT : Auditory feedback of frontal or temporal EMG during 20-min sessions twice weekly for 6 weeks

OTHER TREATMENT : None reported

**\*\*RESULTS**

SYMPTOMS : Average pretreatment, posttreatment, and follow-up levels: intensity, 1.1, .8, and .2; frequency, 5.4, 3.8, and 2.2; average number of medications used: 6.5, 8.5, and 2.6

BIO. FUNCTION : Average microvolt levels: pretreatment, 5.6, posttreatment, 2.9 and follow-up, 3.6

STUDY : Raskin, Johnson, Rondestvedt, 1973

PATIENTS : 6 males, 4 females; average age, 27; 4 had tension headaches

BIOF. TREATMENT : Auditory feedback of frontal EMG levels during 1-hour sessions 5 times weekly until EMG activity averaged less than 2.5 Mv for 25 min

OTHER TREATMENT : Instruction to relax specific muscle groups aided by feedback; training sessions without feedback interspersed; home relaxation

Treatment

once some progress was apparent; "pain medication for headache"

**\*\*RESULTS**

**SYMPTOMS** : 3 of 4 patients were rated as "markedly improved," and 1 as "moderately improved" in symptom intensity; "the 4 patients ... experienced considerable reduction in the frequency and intensity ... they learned to ... abort anticipated or beginning headaches and even to diminish the pain of an established headache"

**BIO. FUNCTION** : The group reduced EMG levels from an average of 14.1 mv/min during a 2-week baseline, to less than 2.5 mv/min during an average of 6 weeks of training (range 2 to 12 weeks)

**STUDY** : Reeves, 1976

**PATIENTS** : Female, age 20 with a 5-year history of headache

**BIOF. TREATMENT** : Auditory analogue feedback of frontal EMG during 20-min sessions, 3 times weekly for 6 weeks

**OTHER TREATMENT** : "Stress management" 15 min daily; "cognitive skills training"

**\*\*RESULTS**

**SYMPTOM** : Average hourly headache activity: baseline, 1.9; cognitive skills training, 1.2; biofeedback, .6; follow-up, .5

**BIO. FUNCTION** : Average levels of frontal EMG (Mv rms): baseline, 9; biofeedback, 5.9; follow-up, 5

Treatments

#### 4.2 TREATMENTS FOR MIGRAINE HEADACHES

STUDY : Andreychuk, Skriver, 1975

PATIENTS : 33 volunteers

BIOF. TREATMENT : Feedback of hand temperature for 45 min, once each week for 10 weeks

OTHER TREATMENT : None reported

##### \*\*RESULTS

SYMPTOMS : Average scores on a headache index for patients scoring high on a hypnotic induction profile: baseline, 156; last 5 weeks of training, 48; average scores for those scoring low on a hypnotic induction profile: baseline, 26; training, 17

BIO. FUNCTION : Data unavailable

STUDY : Bianchard, Theobald, Wiljiamson, Silver, Brown, 1978

PATIENTS : 25 females, 5 males; average age 39, range 21 to 77; average symptom duration 20 yrs, range 5 to 40

BIOF. TREATMENT : Visual feedback of finger temperature during 30-min sessions, twice weekly for six weeks

OTHER TREATMENT : Autogenic training and home practice of handwarming for 5 to 10 minutes, 2 to 3 times each day

##### \*\*RESULTS

SYMPTOMS : Average levels per week during the baseline, training, and 1 to 3 month follow-up: headache index, .74, .4, and .29; frequency, 3.2, 2.2, and 1.4; duration, 13.5, 7.6, and 2.0; medication index, 13, 7.6, and 6.7;

Treatment

intensity, 3.0, 1.9, and 1.4

BIO. FUNCTION : Data unavailable

STUDY : Diamond, Medina, Diamond-Falk, De Veno, 1979

PATIENTS : 123 with vascular headaches, 265 with combined vascular and muscle contraction headaches; age range 10 to 71

BIOF. TREATMENT : Auditory analogue feedback of frontal EMG activity for 10 min and finger temperature for 20 min, 2 to 10 times weekly for up to 4 weeks

OTHER TREATMENT : Relaxation exercises; home practice twice a day for up to 4 weeks

**\*\*RESULTS**

SYMPTOMS : Percent stating that biofeedback helped their headaches: vascular headache alone, 77; mixed vascular and muscle contraction, 73

BIO. FUNCTION : Data unavailable

STUDY : Drury, De Risi, Liberman, 1979

PATIENTS : 2 males, 2 females; age range 29 to 65

BIOF. TREATMENT : Auditory and visual feedback of finger skin temperature while silently repeating autogenic phrases for 30 to 40 min, once or twice weekly for 15 to 21 sessions

OTHER TREATMENT : Reading an article to generate favorable expectations; relaxation training, imagenary, and home practice

**\*\*RESULTS**

SYMPTOMS : Scores on a headache severity index (from 1 to 5) decreased by .9 to 1.5; one patient eliminated all medication; 3 others decreased usage

Treatment

by about 40%

BIO. FUNCTION : All patients raised finger skin temperature by at least 4 F within a session following 1 to 3 weeks of training

STUDY : Feuerstein, Adams, 1977

PATIENTS : 1 male, 1 female; average age 31

BIOF. TREATMENT : Auditory feedback of frontal EMG during six sessions and temporal blood flow feedback during 6 sessions, each 20 min long

OTHER TREATMENT : Home practice for 10 min two times each day

**\*\*RESULTS**

SYMPTOMS : Average levels per week during the baseline, training, and 9-week follow-up; frequency, 2.8, 1.4, and .8; duration, 13, 14 , and 5; intensity, 1.9, 3.3, and 1.7

BIO. FUNCTION : Data unavailable

STUDY : Feuerstein, Adams, Belman, 1976

PATIENTS : Female, age 67 with combined migraine and tension headache

BIOF. TREATMENT : Feedback of frontal EMG for 20 min, once weekly for 6 weeks followed by feedback of cephalic vasomotor responses for 30 min, once weekly for 6 weeks

OTHER TREATMENT : Home practice for 10 min twice daily

**\*\*RESULTS**

SYMPTOMS : Average weekly headache frequency: baseline, 4.4; EMG feedback, 1.8; baseline, 3.3; CVMR feedback, 1.3; 8-week follow-up, 2.5; average intensity (rated 1 to 4): baseline, 2.8; EMG feedback, 1.5;

Treatment

baseline 2.1; CVMR feedback, 2.6; 8-week follow-up, 1.3; average duration: baseline 15.8; EMG feedback, 5.3; baseline, 9.9; CVMR feedback, 4.6, 8-week follow-up, 7.5; no headache reported for 3 weeks during CVMR feedback; use of tranquilizers was reduced from 3 to 1 during the study

BIO. FUNCTION : Frequency of vasospasm during baseline, feedback, and baseline of sessions 5 and 6: EMG feedback, 7.7, 5.3, and 2.9; CVMR feedback, .8, 1.1, and .4

STUDY : Friar, Beatty, 1976

PATIENTS : 16 females, 3 males; average age 30

BIOF. TREATMENT : Auditory and visual feedback of skin temperature over the temporal artery during 8, 200-heartbeat trials in 3 weeks

OTHER TREATMENT : None reported

#### \*\*RESULTS

SYMPTOMS : Compared to average levels in a 30-day baseline, major attacks were reduced by 46%, number of episodes were reduced by 36%, intensity was reduced by 4%, and medication consumption was reduced by 45%

BIO. FUNCTION : Average pulse amplitude decreased by 16% during training

#### 4.3 RAYNAUD'S DISEASE

STUDY : Blanchard, Haynes, 1975

PATIENTS : Female, age 28

BIOF. TREATMENT : Feedback of changes in finger skin temperature during 2, 20-min sessions

Treatment

OTHER TREATMENT : None reported

**\*\*RESULTS**

SYMPTOMS : Prior to treatment, episodes of "painful vasoconstriction" occurred once monthly; by the 7-month follow-up, "the clinical problem of Raynaud's disease was mostly abated"

BIO. FUNCTION : Average hand temperature of 79 F rose to 91.1 F following training, and remained at 88.3 F at 7-month follow-up

STUDY : Jacobson, Hackett, Surman, Silverberg, 1973

PATIENTS : Male, age 31

BIOF. TREATMENT : Feedback of changes in finger skin temperature during 4, 15-min sessions

OTHER TREATMENT : Autohypnosis and thermal suggestions

**\*\*RESULTS**

SYMPTOMS : Initial complaint was blueness and tingling of hands; "by the last session, the patient could induce changes in both the color and temperature of his hands," and could grasp cold objects without experiencing a vasospasmodic attack

BIO. FUNCTION : Temperatures increased bilaterally from 3.9 C to 4.3 C during the final sessions; a 7 1/2 month follow up indicated that the subject was still as effective in controlling hand warmth as during training

STUDY : Peper (in Surwit, 1973)

PATIENT : Female, age 50

BIOF. TREATMENT : Feedback of changes in finger skin temperature during 10-min

Treatment

sessions, twice daily for 30 days

OTHER TREATMENT : Relaxation and autogenic training

**\*\*RESULTS**

SYMPTOMS : Following treatment, the patient "reported that for the first time in 30 years she could hold on to the cold steering wheel of her car without gloves"

BIO. FUNCTION : Basal finger temperature of 75 F increased to 85 F

STUDY : Surwit, 1973

PATIENTS : Female, age 21

BIOF. TREATMENT : Feedback of left hand temperature for 30 min, 14 times during a three-week period; this was followed one month later with 20-min sessions twice weekly for 16 weeks and then at weekly intervals for six months

OTHER TREATMENT : Relaxation, autogenic imagery, counseling, and assertiveness training

**\*\*RESULTS**

SYMPTOMS : "Vasospasms in left hand and face" prior to training; "markedly decreased attacks" following training; at one year follow-up, patient complained of pain even when skin temperatures were normal and reported losing all ability to control skin temperature

BIO. FUNCTION : After a year of training basal skin temperatures rose bilaterally from 23 C to an average of 26.6 C

STUDY : Surwit, Pilon, Fenton, 1978

Treatment

PATIENT : 32 females, age range 27 to 54

BIOF. TREATMENT : Visual feedback of changes in finger skin temperature during six, 45-min sessions in 11 weeks while performing autogenic relaxation response

OTHER TREATMENT : Autogenic training, home practice twice daily for 15 min, and a "response generalization" technique

**\*\*RESULTS**

SYMPTOMS : Average number of attacks decreased from 2.3 per day during the four weeks preceding training, to 1.6 during training; severity ratings also decreased

BIO. FUNCTION : Average increase of .3 C while listening to autogenic instruction; no other increases during the session; "the patients were able to maintain near normal levels of digital skin temperature after an hours exposure to ambient temperatures 17 C"

Treatment

## 2.4 TREATMENTS FOR ASTHMA

STUDY : Danker, Miklich, Pratt, Creer, 1975

PATIENTS : Study one: 6 male inpatients; age range 9 to 12; Study two:  
5 male inpatients; age range 8 to 12

BIOF. TREATMENT : Study one: visual feedback for increases in peak expiratory  
flow rates during sessions involving 10 consecutive blows; study two: same as  
study one with 20 blows per session and including 5 to 22 sessions in 5 weeks

OTHER TREATMENT : Medication

### \*\*RESULTS

SYMPTOMS : Data unavailable

BIO. FUNCTION : No improvement in peak flow rates in stud one; 3 of 5  
children showed a significant number of "improvement sessions" during study  
two

STUDY : Davis, Saunders, Creer, Chai, 1973

PATIENTS : 24 children, age range 6 to 15

BIOF. TREATMENT : Auditory analogue feedback of frontal EMG levels during  
Jacobsonian relaxation; each sessions lasted 30 mins, once daily for 5 days

OTHER TREATMENT : Medication

### \*\*RESULTS

SYMPTOMS : Data unavailable

BIO. FUNCTION : Levels of frontal EMG averaged 19 microamps during  
feedback; peak expiratory flow rates increased by an average of 5 L/min

Treatment

STUDY : Feidman, 1976

PATIENTS : 3 male and 1 female inpatients; age range 10 to 16

BIOF. TREATMENT : Auditory analogue feedback of changes in total respiratory resistance during 5-to 10-min sessions

OTHER TREATMENT : Medication

**\*\*RESULTS**

SYMPTOMS : Data unavailable

BIO. FUNCTION : Pre-to postfeedback changes expressed as a percent of the expected normal values: Peak flow, 63% to 66.8%; Maximum midexpiratory flow, 34.2% to 42%; Total respiratory resistance, 282% to 218%

STUDY : Khan, 1977

PATIENTS : 80 children; age range 8 to 15

BIOF. TREATMENT : Visual feedback for increases in FEV during 5 to 8, 50-min sessions in phase one; in phase two, the feedback was preceded by instigation of bronchoconstriction during 10 sessions

OTHER TREATMENT : Medication

**\*\*RESULTS**

SYMPTOMS : Aveage levels during the 1st, 2nd, 3rd, and 4th quarters of the years following completion of training: number of attacks 23, 18, 12, and 11; duration of attacks, 34, 27, 17, and 17; severity, 42, 33, 21, and 20

BIO. FUNCTON : Following instigation of bronchial constriction, FEV level returned to basal averages

STUDY : Khan, Staerk, Bonk, 1973

Treatment

PATIENTS : 20 children; age range 8 to 16

BIOF. TREATMENT : Visual and verbal feedback for increases in FEV during 15 sessions lasting up to 10 mins; one additional session at 1, 3, and 6 months after completion of training; instigation of bronchial constriction preceded feedback during the final 10 sessions

OTHER TREATMENT : Medication

**\*\*RESULTS**

SYMPTOMS : Average levels before and after training; medication frequency, 108 and 39; hospital emergency room visits, 88 and 13; number of attacks, 413 and 193; number of hospitalizations, 5 and 0

BIO. FUNCTION : Data unavailable

STUDY : Kotses, Glaus, Crawford, Edwards, Scherr, 1976

PATIENTS : 27 male and 9 female asthmatic children in a summer treatment camp; age range 8 to 16

BIOF. TREATMENT : Auditory analogue feedback of frontal EMG levels during up to 20-min sessions twice weekly for three weeks

OTHER TREATMENT : Medication

**\*\*RESULTS**

SYMPTOMS : Data unavailable

BIO. FUNCTION : Average uV levels of frontal EMG in weeks #1, 2, and 3: 16, 10, and 12; average increases in peak flow rates (L/min) during weeks #1, 2, and 3: 30, 28, and 27

#### 4.5 TREATMENTS FOR EPILEPSY

Treatment

STUDY : Cott, Pavloski, Black, 1979  
PATIENTS : 4 females, 3 males; age range 15 to 30  
BIOF. TREATMENT : Auditory and visual feedback for decreases in 4 to 7 Hz EEG activity for three people; feedback for decreases in 4 to 7 Hz activity and feedback for increases in 12 to 14 Hz for the remaining four; sessions lasted 40 mins, twice weekly for 6 weeks  
OTHER TREATMENT : Anticonvulsant medication

\*\*RESULTS

SYMPTOMS : Seizure frequency decreased for five people  
BIO. FUNCTION : 12 to 14 Hz activity increased in 3 people; 4 to 7 Hz activity decreased in five

STUDY : Finley, Smith, Etherton, 1975  
PATIENTS : Male, age 13 with 11-year history of convulsions  
BIOF. TREATMENT : EEG was recorded from approximately C3 and F3 with reference at A2; auditory and visual feedback for increases in 11 to 13 Hz activity and for decreases in 4 to 7 Hz activity during 45 sessions; each session lasted 50 mins, 3 times weekly for about 6 months  
OTHER TREATMENT : Valium 30 mg t.i.d, Phenobarbital 60 mg t.i.d.

\*\*RESULTS

SYMPTOMS : Seizure rate per hour: baseline, 8; sessions 1 to 34, 2.7; sessions 35 to 80, .7  
BIO. FUNCTION : Percent of 11 to 13 Hz activity in the EEG: baseline, 10; sessions 35 to 80, 55; percent of 4 to 7 Hz activity: baseline, 45; sessions

Treatment

1 to 34, 25; sessions 35 to 80, 19

STUDY : Finley, 1976  
PATIENTS : Male, age 15; same as studied by Finley, Smith, Etherton,  
1975  
BIOF. TREATMENT : EEG was recorded from approximately C3 and F3 with  
reference at A2; auditory and visual feedback for increases in 12 Hz activity  
in the absence of 5.5 Hz waveforms  
OTHER TREATMENT : Valium 30 mg t.i.d., Phenobarbital 60 mg t.i.d.

\*\*RESULTS

SYMPTOMS : Seizure rate per hour: before false feedback, .30; false  
feedback, .43; proportion of urine-loss events increased during false  
feedback

BIO. FUNCTION : Percent of 12 Hz activity in the EEG: before false  
feedback, 70; false feedback, 63 after false feedback, 75; percent of 5.5 Hz  
activity in the EEG: before false feedback

STUDY : Finley, 1977  
PATIENTS : Male, age 15  
BIOF. TREATMENT : EEG was recorded from approximately C3 and F3 with a  
reference at A2; auditory and visual feedback for 11 to 13 Hz activity in the  
absence of 4 to 7 Hz waveforms  
OTHER TREATMENT : Medication

\*\*RESULTS

SYMPTOMS : Seizure frequency decreased to less than one per hour

Treatment

BIO. FUNCTION : Percent of 5.5 Hz activity in the EEG: 15

STUDY : Johnson, Meyer, 1974

PATIENTS : Female, age 18; 10-year history of grand mal seizures

BIOF. TREATMENT : EEG was recorded from O(z) and T4 with ground on right ear; alpha feedback followed by training of 6.5 to 9.5Hz activity

OTHER TREATMENT : Two weeks of relaxation training; EMG training; medication

\*\*RESULTS

SYMPTOMS : Seizure rate was reduced from three per month during the baseline to 1.5 per month following 12 months of training; no more than one seizure per month was reported during the 3-month follow-up

BIO. FUNCTION : Data unavailable

STUDY : Kaplan, 1975

PATIENTS : 3 females, 1 male; seizure histories ranging from 6 to 21 years

BIOF. TREATMENT : EEG was recorded from about C4 with reference at A2.

Feedback for increases in 12 to 14 Hz activity during experiment one;

feedback for increases in 6 to 12 Hz activity in experiment two; sessions

lasted 30 mins, three times weekly for 3 to 4 months in experiment one and

for 5 to 6 months in experiment two

OTHER TREATMENT : Range of anticonvulsants

\*\*RESULTS

SYMPTOMS : Average frequency of seizures: 207 prior to feedback, 202 during experiment 1, 132 during experiment 2, and 60 after termination

Treatment

BIO. FUNCTION : No change in the proportion of 12 to 14 Hz activity present during experiment 1, no significant change in 6 to 12 Hz activity present during experiment 2

STUDY : Kuhlman, Allison, 1977

PATIENTS : 5 females; age range 14 to 42

BIOF. TREATMENT : EEG was recorded from C3 area; feedback of 9 to 14 Hz activity for 30 mins, three times weekly; false feedback (based on previous session EEG) for 30 mins, three times weekly for 4 weeks in phase one; feedback of 9 to 14 Hz activity for 30 mins, three times weekly for at least 8 weeks in phase two

OTHER TREATMENT : Anticonvulsants

**\*\*RESULTS**

SYMPTOMS : Seizure activity decreased by 40% for two of five patients in 14 weeks, and decreased by 25% for 3 patients in 9 weeks; seizure frequencies increased by 5% during false feedback

BIO. FUNCTION : No change in 9 to 14 Hz activity or in 3 to 6 Hz activity

STUDY : Luber, Bahler, 1976

PATIENTS : 6 studied by Seifert and Luber (1975) plus two additional patients

BIOF. TREATMENT : EEG was recorded from C3-T3 on the left hemisphere and C4-T4 on the right; auditory and visual feedback for increases in 12 to 14 Hz waveforms in the absence of 4 to 7 Hz activity; sessions lasted 40 mins, three times weekly for about 7 months

OTHER TREATMENT : Anticonvulsants

**\*\*RESULTS**

SYMPTOMS : Seizure frequency, duration and intensity decreased for some patients; two patients with multiple seizures per week have been seizure free for up to one month

BIO. FUNCTION : 12 to 14 Hz activity increased by 30% during the feedback sessions

STUDY : Seifert, Lubar, 1975

PATIENTS : 3 females, 3 males

BIOF. TREATMENT : EEG was recorded from left and right Rolandic cortex 10% and 30% off vertex with reference to ear; auditory and visual feedback of 6, 12 to 14 Hz waveforms lasting .5 seconds in the absence of 4 to 7 Hz activity during 30-min sessions, 3 times weekly for 3 to 4 months

OTHER TREATMENT : Anticonvulsants

**\*\*RESULTS**

SYMPTOMS : Seizure frequency decreased from an average of 72 per month before training to 24 per month after training

BIO. FUNCTION : Percent of 12 to 14 Hz activity in the EEG: baseline, 8.7; training, 12.7; training, 12.7; slow wave activity decreased during training

STUDY : Sterman, 1973

PATIENTS : 4 epileptics

BIOF. TREATMENT : EEG was recorded from approximately C3; visual feedback for increases in 12 to 14 Hz activity during 30- to 60-min sessions up to 2 times

Treatment

weekly

OTHER TREATMENT : Anticonvulsants

**\*\*RESULTS**

SYMPTOMS : Lowest rates of seizure activity were achieved in all patients

BIO .FUNCTION : Increases in 12 to 14 Hz activity was observed in all patients; decreases in abnormal low frequency discharge patterns

STUDY : Sterman, 1977a

PATIENTS : 1 female, 2 males; age range 19 to 28

BIOF. TREATMENT : EEG was recorded from approximately C3 and T3, and at P3 and O1. Visual feedback for enhancement or suppression of either 12 to 15 Hz, 6 to 9 Hz 18 to 23 Hz activity ; lab sessions for 1 to 3 weeks followed by home training for 30 mins 6 times weekly

OTHER TREATMENT : Anticonvulsants

**\*\*RESULTS**

SYMPTOMS : By the end of training, seizures had ceased in two patients and decreased by 50% in the third

BIO. FUNCTION : Training at both higher frequencies normalized the EEG, reducing abnormal low frequency paroxysms

STUDY : Sterman, 1977b

PATIENTS : Female, age 19; male, age 28 (same as studied by Sterman, 1977a)

BIOF. TREATMENT : Same as in Sterman, 1976

Treatment

OTHER TREATMENT : Anticonvulsants

\*\*RESULTS

SYMPTOMS : Seizure frequency improved; see case study

BIO. FUNCTION : Training at both higher frequencies reduced epileptiform activity and increased 12 to 15 Hz sleep spindles

Treatment

## V. BIOFEEDBACK INSTRUMENTATION

Main instruments used in biofeedback applications are EMG, EEG and skin temperature feedback instruments. Heart rate, blood pressure and GSR (galvanic skin response) measuring devices are used as secondary instruments.

### 5.1 EMG INSTRUMENTATION

Biofeedback applications from the musculoskeletal system can be broadly divided into feedback to diminish electrical potentials present in the muscle as in relaxation related biofeedback and feedback to enhance potentials as in neuromuscular re-education. Surface electrodes are always used except for special applications.

When a reduction in muscle activity, which brings lower arousal level or relaxation, is desired, then the recording site is the frontalis muscle located in the forehead. It has some advantages from the standpoint of relaxation training; it is often a direct expessor of stress within the musculoskeletal system. It is not a postural muscle and therefore its activity can be reduced to very low potentials without regard for positioning the patient, it is readily accessible for instrumentation. Any standart skin electrode such as the one provided with most biofeedback devices can be used. It must be placed on the forehead, approximately 1.5 inches above the center of each eyebrow. The skin oil may be removed with alcohol, and the area allowed to dry. A cotton-tipped applicator should be used to "twirl" small quantity of

conducting gel with an abrasive material on the site with the end-most surface of the cotton tip. Surface electrodes are usually affixed to the skin either holding them on the skin with an adhesive collar designed for that purpose.

For frontalis biofeedback applications two recording electrodes and a ground electrode in the middle of them are used. In most cases the resistance between any two electrodes in the system is less than 30 KOhm.

Some devices have logarithmic scales and usually do not require sensitivity or threshold settings. When using such a device, the task is simply to move the needle of the meter in the direction of the lower number until the goal is reached and maintained. On devices with linear scales, there are usually a choice of sensitivity ranges and threshold settings which the therapist may use. The therapist should set the sensitivity sufficient to allow small reductions in muscle activity to be detected, but insensitive enough to prevent the dial from reaching the top of the scale often in a session. As the patient learns control of muscle activity and is able to reduce it at will, the therapist will need to reset the machine to detect levels close to the goal.

For relaxation exercises other sites can also be chosen, such as the forearm, the thigh, the back of the neck, the jaw muscle of patients who brux or jaw clench, or the stump in phantom limb pain. For each of these sites, the electrodes should be placed approximately 2 inches apart over the most prominent part of the muscle or the most tense ridge. The skin preparation and

method of attachment are the same as for the frontalis muscle.

Movement which is a result of some muscle activity and ECG signals (in most EMG sites other than frontalis) can affect EMG signals. The most useful method to reduce ECG artifact is to place the two recording and ground electrodes on a straight line from the heart to the distal-most electrode. ECG artifact is recognizable by the electrical signal of the heart beat, causing the feedback signal to fluctuate in a detectable rhythmic way.

Goals in EMG feedback are determined by the pretreatment resting levels and the choice of muscle sites. When the frontalis is used, an average of 5uV is usually sought as the ultimate goal. It may be set as an initial goal also when the resting baseline level does not exceed 20uV. When 20uV is exceeded, the initial goal is usually to reduce the activity to one-half of the baseline levels. When using portable devices where microvolt levels are not available, an initial goal might be to reduce the dial reading to one-half of its level in the initial session and then revise the goal downward until an average of 5uV is reached.

When biofeedback is used to reinstate muscle function as in neuromuscular re-education, the biofeedback task is to increase levels of muscle activity, and the goal is some level above the baseline readings which is just the opposite of the case in relaxation training. In this case, selection of the target muscle must be based on the desired movement. All of the conditions in relaxation training with EMG applies as far as instrumentation is considered

while the machine settings are opposite. At the beginning of treatment, the machine is set to be very sensitive, and the threshold set low so that very small increases in muscle potential can be detected. The task is to increase the meter reading, and movement of the muscle will take place as a by-product of that increase. The same artifacts apply in this application, but the movement that is likely to contaminate the feedback signal may be from some other part of the body. EMG biofeedback goals for this application are often set by monitoring the same muscles on the opposite side of the body and determining the normal functional level for that muscle.

## 5.2 SKIN TEMPERATURE FEEDBACK

Changes in blood flow at the surface of the skin result in temperature variations detectable with temperature-sensitive instrumentation. Often a finger is selected for biofeedback application, but sometimes the palm of the hand or the forehead is used. Usually, a thermistor serves as a transducer. It is fixed to the skin during the session. When the finger is selected, then the thermistor is placed along the side of the finger and held in place with a length of tape. The tape should be wrapped around the finger at an angle rather than like a ring in order to reduce the possibility of restricting blood flow with tape.

A biofeedback machine takes the temperature information from the thermistor and feeds it to the subject in form of meter reading or tone. Sensitivity of the device refers to the value in degrees of the total visible scale. When the

patient is beginning the temperature task, the most useful setting is the most sensitive one, so that small changes are rewarded. At least ten minutes adjustment period is necessary, just after instrumentation of the patient, in order to have a stabilised transducer output.

First, the patient should be instructed to observe the meter face. If the meter moves in the direction which indicates that the temperature is decreasing, then the patient should say himself, "that's cooler", and vice versa. After a short period of identification, the patient is ready to begin learning to control temperature variations. When the needle moves in the desired direction, the the patient should be encouraged to reward himself by suggesting that the result is good and is what he wants to do. The patient should be able to move the temperature easily at least 1 1/2 degrees in either direction with subjective awareness of when the task is accomplished.

Climate and the ambient temperature effects the thermistor output to some extent. The position and place of the hand must be the same during each session because whether the hand is rested against some part of the body or whether it is used on a table or arm rest can influence the surface temperature. If the hand is held higher than the rest of the body, then it tends to be cool and if it is held low, then it tends warm. Therefore the level of the arm should remain constant during sessions. Another point is the position of fingers. If they are close each other then their temperature is higher than when they are apart so that air circulation between them can cool them. For this reason the relative position of fingers should also remain

constant in all biofeedback sessions.

### 5.3 EEG FEEDBACK

The signal can be detected from the surface of the scalp by applying EEG electrodes which are flat cup-shaped. In EEG feedback the main application is the alpha feedback.

Alpha frequencies within the EEG are most abundant over the occipital cortex. Therefore the active recording electrode should be placed in this region, determined by locating the external occipital protuberance (the bony process at the lower back portion of the skull) by moving the fingers up the center of the back of the neck until the most prominent point is found. From that point a distance of 1 in upward and 1 in to the left will locate the site for the left occipital electrode. If the right side is preferred, it may be located in the same manner, but by moving 1 in to the right of center. The site of second recording (or reference) electrode may be located by first imaging a line from the bridge of the nose across the top of the head to the external occipital protuberance, the prominent point located earlier. A second line should be imagined running from the external auditory meatus, the hole in the ear, on one side across the top of the head to the same location on the opposite side of the head. Where these imaginary lines cross at the top of the head is called the vertex. Starting at the vertex and moving 2 in along the imaginary line toward the left external auditory meatus will locate the site for the reference electrode if it is to be located on the left and recorded

against an electrode placed at the left occipital location. Active and reference electrodes must be on the same side since the two hemispheres emit asymmetrical electrical signals. The ground electrode may be placed on the ear lobe or the bony mastoid process behind the ear or on any other electrically quiet place on the head. Surface oil may be removed by wiping the area with alcohol and allowing the area to dry and EEG paste or cream should be applied. The electrode should be pressed into the mound of cream so that the cup of the electrode is filled with cream and the metal surface of the electrode is placed against the scalp rather than the hair.

With the electrodes in place, the impedance should be measured between each pair of electrodes and the other two pairs include the ground electrodes and the other two pairs include the ground electrode and each of the two recording electrodes. A valid impedance level for any instrument in current use is less than 10,000 Ohms, which is easily achieved with good application technique.

Required adjustments usually include setting the filters to detect only frequencies within the alpha bandwidth of 8-12 Hz. The sensitivity adjustment is sometimes labeled "amplitude" on an EEG machine. The threshold adjustment determines how much of the alpha that the machine is detecting is to be considered for feedback.

If the threshold is set so that only the peaks of average or greater height are rewarded with the feedback signal, then it appears to the patient that half of the peaks are as desired and half need improvement. This is a good level, since there is enough reward to give to the patient (early feeling of success) and still allow him to see that there is room for improvement. If on the other hand, the threshold is set too high so that only the very highest peaks are rewarded, the patient is likely to see the task as a source of frustration and react in a stressful manner to it, thus defeating the purpose of the entire biofeedback program. By setting the threshold so that 50 % of the total effort is rewarded in the early phases, and adjusting the threshold each time the patient reaches 70 % feedback, a balance can be maintained and the physiological skill can be shaped in the desired direction. Thirty minutes of feedback is the optimum amount for any feedback session and sessions should be planned so that during the course of treatment, the patient receives a total of not less than 300 minutes of EEG alpha feedback.

Goals for the alpha biofeedback must be set in light of the machine's method of quantifying EEG alpha abundance. If the machine reports percent time, then the goal may be to achieve 99 % time over a specified number of minutes. If the machine quantifies in a standard unit of measure, such as the microvolt, then the goal should be in the range of achieving 140 % over baseline amplitudes. In either case, it is important to continue the feedback sessions until 300 minutes of feedback time have been exceeded whether or not the amplitude goal has been reached.

Movement results in muscle signals which are so much greater than the EEG signal that the EEG is lost within them. For some people eye position is an important factor determining EEG alpha abundance. Alpha is increased in many people by simply closing the eyes, and when the eyes are strained in any position away from center, there may be a muscle twitching that occurs in the same frequency range as alpha and influences the feedback. Alpha is enhanced as the patient is able to maintain himself in a relaxed but alert state.

#### 5.4 HEART RATE AND HEART RHYTHMS

Heart rate and heart rhythms are sometimes fed back to the individual producing them by applying electrodes to the chest and putting the signal into a device which produces a feedback signal. Such devices are designed to provide feedback when the heart rate is increased, decreased or maintained within a pre-determined range. Standard clinical ECG electrodes can be used and the sites often selected include placing the active recording electrode on the chest in the space between the third and fourth ribs just to the left of the sternum. The reference electrode may be placed on the patient's left side, midway between the front and back of his body, in a space between two ribs. The ground electrode may be placed on the arm or leg. Skin preparation is not a major consideration. ECG signal is especially strong and slow compared to many other physiological signals, and there is very little that can create artifacts in it. The feedback signal may be a light or tone that tells the patient when he is doing the task or sometimes the actual ECG complex is shown

to the patient on an oscilloscope. Goals of heart rate feedback depends upon the particular condition being treated and the strategy used.

## 5.5 BLOOD PRESSURE

One method of blood pressure feedback is to detect changes in blood pressure through a microphone which rests over the radial artery pulse in the wrist. A second method is to detect the changes in the Korotkoff sound (heard by a stethoscope or microphone only at pressure levels between systolic and diastolic pressure) to indicate changes in the pressure. Another method can be described as follows: A blood pressure cuff is applied in the usual manner and inflated from 3 to 5 mm below diastolic pressure so that the Korotkoff sound is not detectable. In this type of instrumentation, the patient's task is to turn the sound on. To do so, the patient must cause a drop in diastolic pressure to below the inflation level, thus allowing the Korotkoff sound to be detected.

Instrumentation

## VI. BIOFEEDBACK EQUIPMENT

Biofeedback equipments consist of some modules. The functions of these modules are mainly amplifying, filtering, timing, gating, delaying, counting, integrating and displaying signals in auditory and visual modes. An equipment is particularly useful for the programming of complex experiments and is often used with multichannel physiological recorders (polygraphs).

### 6.1 EMG FEEDBACK EQUIPMENT

**FUNCTION :** The portable EMG biofeedback unit is designed to detect muscle activity and feedback suitable information to the subject about the activity level of the muscles measured. It functions as arrow 2 in Fig. T-2. It uses skin surface electrodes as transducer and has typical component configuration shown in Fig. E-1 of transducer, signal amplifier, signal processor and signal display.

**SAFETY :** The battery powered unit does not have the shock hazard of the line-powered units and is, therefore, recommended.

#### EQUIPMENT SPECIFICATIONS :

Input impedance : >1 MOhm  
Input configuration : differential input preamplifier  
CMRR (at power line freq.) : >80 dB

Bandwith : 20 Hz - 1 kHz  
Amplitude : 1-100 uV rms  
Time constant of O/P circuit : 0.25 sec - 1 sec  
Electrodes (type) : skin surface electrodes  
Electrodes (material) : Ag/AgCl (preferred), stainless steel  
Input equivalent noise : <1 uV

For monitoring muscle activity in the neck or back region, a lower frequency cut-off of 100-Hz can help to eliminate ECG artifacts. A built in circuit for measurement of electrode to electrode resistance is a very useful feature, but should give a relative indication on a meter and not just consist of a poor-contact warning light. For rejection of power line interference addition of a notch filter is recommended.

FEEDBACK MODALITIES : If both, auditory and visual modes of feedback are present, then this system is very valuable in EMG applications. The most common auditory feedback used is a clicking sound or tone that increases in frequency as the input signal increases in amplitude. Visual feedback is normally given by an analog meter that provides amplitude information as well as a means for comparing performance during and between sessions. Those instruments equipped with meters either provide a gain control, giving several fullscale sensitivity ranges, or they make use of a non-linear (usually log or semi-log display that covers a wide range of input amplitudes. The latter method has the advantage of providing a larger meter deflection for a given change in amplitude at the low end of the scale where further reduction

becomes more difficult. This method also eliminates the need to change ranges, and therefore to establish new goals, as relaxation progress. Digital numerical displays as a continuous visual feedback are not very practical.

## 6.2 TEMPERATURE FEEDBACK EQUIPMENT

**FUNCTION :** The portable skin temperature feedback instrument is designed to measure and display changes in skin temperature from a selected body site. The blood flow is controlled largely by autonomically mediated arteriolar changes and skin temperature is mainly controlled by the thermal transfer from blood flow to the part. As a result monitoring changes in blood flow gives an information about the state of autonomic systems to the input stages of sensory systems, so it fulfills the function of the arrow 3 in Fig T-2. The transducer is usually a thermistor which is usually taped to the skin with a small piece of adhesive tape. The temperature measurement is usually read from a meter calibrated to read in degrees.

**SAFETY :** Since most temperature feedback equipments are battery powered and portable, they do not have the shock hazard of the line-powered units.

**EQUIPMENT SPECIFICATIONS :** Most available instruments monitor one location for absolute temperature changes. The units should have a meter output and sensitivity should be changeable to permit full scale deflections ranging from several degrees Fahrenheit to 10-20 degrees. Without the high sensitivity

setting the subject may not be able to work as well with the instrument during the early stages of training.

An analog meter output is preferable to a digital readout as trends and small changes are more easily followed. Instruments are also available with auditory feedback in the form of a tone, the frequency of which is proportional to temperature. A light bar readout is also satisfactory provided the resolution is great enough to permit detection of changes on the order of 0.05 degrees Fahrenheit. An additional desirable feature is derivative feedback which indicates the direction of temperature change even before it is apparent on the temperature feedback display.

### 6.3 GSR FEEDBACK EQUIPMENT

**FUNCTION :** The purpose of portable modular galvanic skin resistance ( GSR ) feedback equipment is to detect and display changes in the skin resistance ( conductance ) caused by changes in the subjects emotional state. It therefore fulfills the function of arrow 3 in Fig. T-2 because GSR is a reflection of autonomic nervous system activity. This parameter is sometimes referred to as electrodermal response ( EDR ) or skin potential response ( SPR ), although the relation of the latter to autonomic activity has not been well studied.

**SAFETY :** Since instruments are battery operated they do not have the shock hazards of the power line units.

EQUIPMENT SPECIFICATION : GSR equipments should use alternating current method. A small AC voltage is applied to the skin and the resulting current flow is measured. Current density should be maintained below 10  $\mu$ A(DC or rms). The instruments should be capable of accepting basal skin impedance from 2 to 2000 kOhms and should reflect resistance changes as small as 200 Ohms. To display phasic changes adequately, the indicating device should be AC coupled to the input signal through a circuit having a time constant of 3 to 5 seconds.

FEEDBACK MODALITIES: While accurate measurements of the basal resistance level is sometimes done in research work and may someday be important clinically, at present only a relative indication of the amplitude and direction of transient resistance changes is usually provided. This is normally performed by an analog meter and/or changing tone.

#### 6.4 EEG ( BRAIN WAVE ) FEEDBACK EQUIPMENT

FUNCTION : Portable EEG feedback equipment is designed to detect and amplify electrical signals generated by the brain, discriminate among the various frequency components, and give information to the subject concerning the amplitude or frequency of these components. This equipment fulfills the function of feedback arrow 1 in Fig. T-2. Skin surface electrodes are used as signal transducer and other components are as shown in Fig. E-1, namely signal

amplifier, signal processor, and signal display. The types are alpha, theta and beta feedback equipments.

SAFETY : All part of the unit should be battery operated or be isolated electrically through the use of optical or magnetic ( transformer ) techniques.

EQUIPMENT SPECIFICATIONS :

Input configuration : differential input stage  
Input impedance : > 2 MOhms  
Input noise level : < 0.5 uV rms  
Input signal level : 1.5 uV - 35 uV rms  
CMRR (at power line freq.) : > 80 dB  
Input dc current : < 50 nA  
Bandwith (alpha & theta) : 4 Hz - 13 Hz  
Bandwith (beta) : 4 Hz - 28 Hz  
Electrodes : Ag/AgCl

A desirable feature is the incorporation of artifact inhibit circuits to squelch feedback resulting from movement artifact. One of the early stages of amplification should be AC coupled to prevent saturation of the amplifier due to electrode offset potential. An analog filter design with at least 18 dB per

octave attenuation of signals outside the passband is recommended. The filter section should have a flat  $\pm 1$  dB response across the band selected. An internal means of checking electrode to electrode resistance is desirable feature available in some units.

FEEDBACK MODALITIES : Although the means by which information is presented to the subject remains somewhat a matter of personal preference, auditory methods are preferable over visual since the subject can work with eyes open or closed, as desired. A steady tone which is made to warble when the feedback criteria are met has been found less alerting by some users when compared to techniques in which the tone is either on or off to signal success. Whichever method is utilized, feedback should appear to be instantaneous, lagging the onset of the triggering signal by not more than 0.5 seconds. It is important that information come as soon as possible and that the continuous discrimination of amplitude be given in some way.

Biofeedback Equipments

## VII. DIGITAL BIOFEEDBACK MONITOR

### 7.1 DESCRIPTION OF THE SYSTEM

Digital Biofeedback Monitor is a data acquisition system for biofeedback sessions. Firstly, it can be used during a biofeedback session to monitor the physiological variable under training by the physician, usually in another room and without disturbing the patient or changing his environmental conditions. Secondly, the data collected during a biofeedback session can be stored onto a disc, which enables the physician to compare different sessions of any patient in order to see the progress of the control over the physiological variable.

Another potential application of DBM is letting the patient see his physiological response on the screen. The monitor could be a better feedback signal than a visual meter or a sound signal.

Digital Biofeedback Monitor consists of a digital computer and an analog to digital converter module. The A/D (analog to digital) module gets the analog signal from an equipment used in biofeedback training such as EMG (Electromyogram), GSR (Galvanic Skin Response), thermometer for skin temperature feedback, converts it into a digital word and places it into the memory of the computer under the control of the associated computer program (A/D control program). Once the data is put into the memory, the computer can plot the graph which reflects the data obtained during the session on the CRT

Digital Biofeedback Monitor

screen, store it on a disc for future references. By using the data on disc or in memory any type of data processing work can be carried out.

First stage of the system is a preamplifier. This preamplifier has been adjusted to accept input signals as high as 200 mV which is also a full scale signal voltage. Any biofeedback equipment which has a dc output can be connected to this system by means of a 3.5 mm jack provided that the full scale signal level is equal or less than 200 mV.

## 7.2 HARDWARE

An AMSTRAD CPC 6128 is used as the digital computer of the system. CPC 6128 is a personal computer with a CRT monitor and integrated disc driver. A Z80A CPU controls the computer unit with a 4 MHz clock frequency. The computer unit consists of 128 Kbytes of RAM and 32 kBytes of ROM.

The expansion port of the computer is used to interface the A/D card to the computer. This port consists of data bus, address bus and control signals related to the computer. An address decode logic is used to select the the PIO (Peripheral Interface Adapter) at the addresses FBF0, FBF1, FBF2, FBF3 (all hexadecimal numbers) when IORQ signal of Z80 CPU is low. 2X74LS30, IC4 and IC6, eight input NAND gates, together with a 74LS04, IC5, 6XINVERTER serve as the address decoder circuit (Refer to Fig H-1). PIO interfaces the computer to the A/D circuit. The method used in analog to digital conversion is SUCCESSIVE APPROXIMATION METHOD. A/D circuit is implemented by a D/A (Digital to Analog)

converter, a 1408, IC2 and a successive approximation register, a MC14549, IC3, a current to voltage converter, LF 356 OP-AMP, IC9, a voltage comparator, LM 301 OP-AMP, IC10.

The working principle of the successive approximation method is as follows: When the necessary timing signals are received from the PIO, then SAR initiates a conversion cycle. First it puts 10000000 (binary) to the input of D/A which generates an associated output current which is converted by IC9 to voltage and compared with the input voltage by the comparator, IC10. If the input voltage is greater than the generated voltage, then second most significant bit is also set by SAR without clearing the most significant bit. If the case is just the opposite, then the most significant bit is reset while the second most significant bit is set. The process repeats itself in such a way that the subsequent bit is cleared or left as it is depending on the state of the comparator from the most significant bit to least significant one. At the end, after the eighth bit, an End Of Conversion signal is sent to the PIO by SAR, which completes A/D conversion cycle, and the present digital word is read by the computer using PIO. This word is placed into the memory (RAM).

At specific time intervals this process repeats itself till the end of the session is reached. The D/A converter, 1408, requires a stable reference current. This current is generated from a voltage regulator chip, IC8, a 78L05, and an adjustable resistor R3. This reference current has been adjusted to 1 mA. Since R4, resistor of the current to voltage comparator, is 10 kOhms

full scale voltage for sampling is 10 V, which is the product of reference current and R4. It means that 10 V corresponds to the digital word FF (255) and one digital unit (corresponding to the word 01) is  $10/256$  V, due to eight bit sampling. Two cascaded amplifiers (IC12 and IC11) amplify the input signal (full scale 200 mV) 50 times to reach the necessary level for sampling (10 V full scale).

A 4.7 V zener diode, D1, and R1 adjust the voltage levels between the comparator and the SAR D-input. IC7 functions as an oscillator to generate the necessary clock pulse for SAR, in form of a multivibrator, consisting of a resistor, R2, and a capacitor, C1, besides IC7.

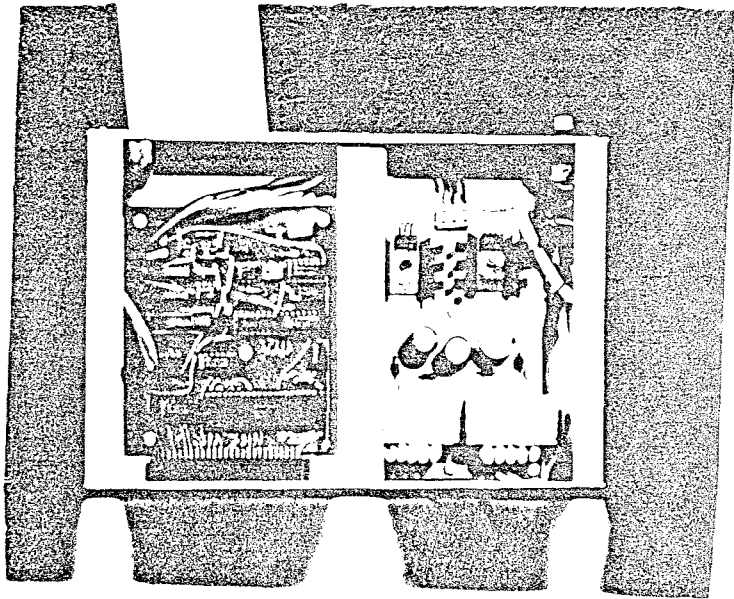
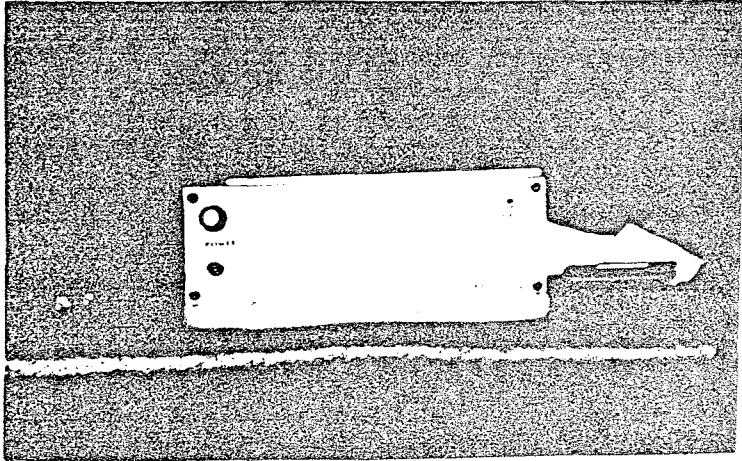



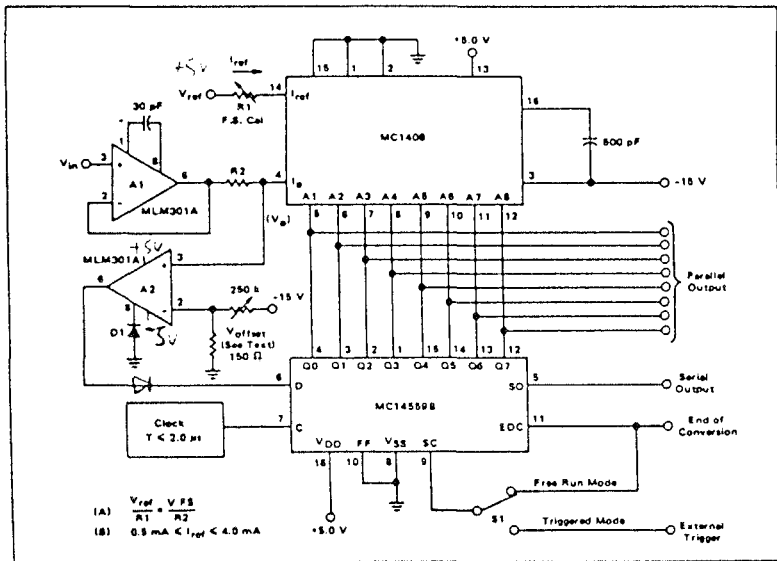

FIGURE 3 - 3-Bit Successive Approximation A/D Schematic Diagram

$$(1) I_o = I_{ref} \cdot X$$

$$\text{and}$$

$$(2) I_{ref} = V_{ref}/R1$$

Where  $I_o$  is the output current sink of the D/A.

The voltage on the output of the D/A,  $V_o$ , is a function of  $V_{in}$  and the output current of the D/A.

$$(3) V_o = V_{in} \cdot R2/R1$$

The comparator, A2, compares  $V_o$  to  $V$  offset which is  $-1/2$  LSB.

If  $V_o$  is greater than  $V$  offset the output of the comparator is a "one".

Full scale voltage (1111111), of the system as set up was 2.56 volts. This gives each LSB a value of 10 mV. Any value of full scale could be chosen as long as one does not saturate the input buffer amplifier (input voltage must stay about 1 volt below the positive supply of the op-amp to keep it out of saturation), and the Equations (A) and (B) are followed. Equations (A) and (B) are shown with Figure 3.

Calibration of the system is very easy. Simply put a voltage of full scale minus  $1/2$  LSB into the input and adjust the full scale calibrate pot (R) to make the transition from 11111110 to 11111111 occur at this point.

Now put an input of  $+1/2$  LSB into the system and adjust the offset adjust pot to set the 00000000 to 00000001 transition to occur at this point. Since the two adjustments described are somewhat interactive it may be necessary to go through the procedure more than once.

As stated earlier the system will run nicely at  $2 \mu\text{s/bit}$  giving a total conversion of  $(n+1) \times 2 \mu\text{s}$ . In this case,  $n$  is 8 so the system has a conversion time of  $9 \times 2$  or  $18 \mu\text{s}$ . The primary limit of speed in the system is the propagation delay time of the comparator (MLM301A) and the SAR. The propagation delay time for the 301A is on the order of  $1 \mu\text{s}$  with a 5 mV over drive. The propagation delay of the SAR is about 450 ns at 5 volts. Adding the prop delays gives about  $1.5 \mu\text{s}$ . When the setting time of the D/A is added in, about 250 ns, we see the total is  $1.75 \mu\text{s}$ . Hence the operational figure of  $2 \mu\text{s/bit}$ . Operational waveforms are shown in Figures 5 and 6.

Figure 4 shows a schematic of another system which is very similar to the one in Figure 3 except that the SAR is running on +12 volts and a MC1710C comparator is used with a one transistor level translator on its output. At 12 volts  $V_{DD}$  on the SAR its prop delay is typically 135 ns. The comparator and level translator has a total prop delay of about 50 ns. Now the total delay time is

135 ns for the SAR, 50 ns for the comparator and the 250 ns for the D/A.

This gives a total time of 435 ns/bit or a 2 MHz clock rate. Total conversion time for this system is  $500 \text{ ns} \times 9$  or  $4.5 \mu\text{s}$ . The cost of the high speed system is about the same as the lower speed version but it requires several more components and the addition of one more power supply, as well as requiring about 400 mW of power. Accuracy, calibration and operation of the high speed version are exactly the same as described for the lower speed system. Therefore, for clock speeds up to 500 kHz the circuit shown in Figure 3 is adequate. However where higher speeds are required, up to 2 MHz, the system shown in Figure 4 should be used.

would be truncated to 4-bits and the MC14549B used for the remaining 8. For more information on cascading of the SAR chips see the MC14559B data sheet.

In this treatise, only binary coded A/D systems have been discussed. All of the circuits shown here and the theory put forth apply equally well to systems of BCD coding, or in most cases to non-linearly weighted systems. The only stipulation being that the D/A used is monotonic. Everything in the circuits shown would be the same for these last two cases except that the D/A converters would have a different transfer function.

#### SYSTEM ACCURACY

The Successive Approximation A/D system has several

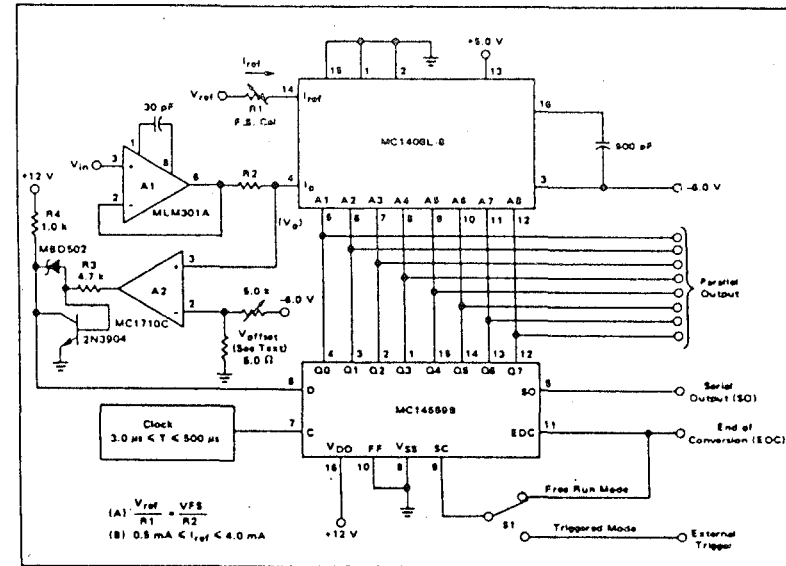

FIGURE 4 - 3-Bit Successive Approximation A/D Schematic Diagram, High Speed Version

Both of the A/D systems described in this paper are 8-bit systems. If desired a 4, 5, 6, or 7-bit system could be implemented using the same configuration as shown in Figure 3 or Figure 4. The only change being the truncation of the length of the SAR, see Figure 7. Note that for a 6-bit system only a 6-bit accurate D/A is required.

If a system of more than 8-bits is required, the MC14559B may be cascaded with the MC14549B to make an SAR of anything from 9 to 16-bits. For 12-bits the MC14559B

sources of error. They are, Quantization error, D/A accuracy, Comparator gain, Offset voltages of components, and D/A settling time. To get a feel for the relative magnitude of each of these, they will be examined individually in detail.

Quantization error is that error inherent in every A/D system. It comes from the fact that the smallest increment the system can resolve is  $\pm 1/2$  of a quantization unit. That is; an  $n$ -bit A/D has  $2^n$  equal quantization levels.

FIGURE 5 -

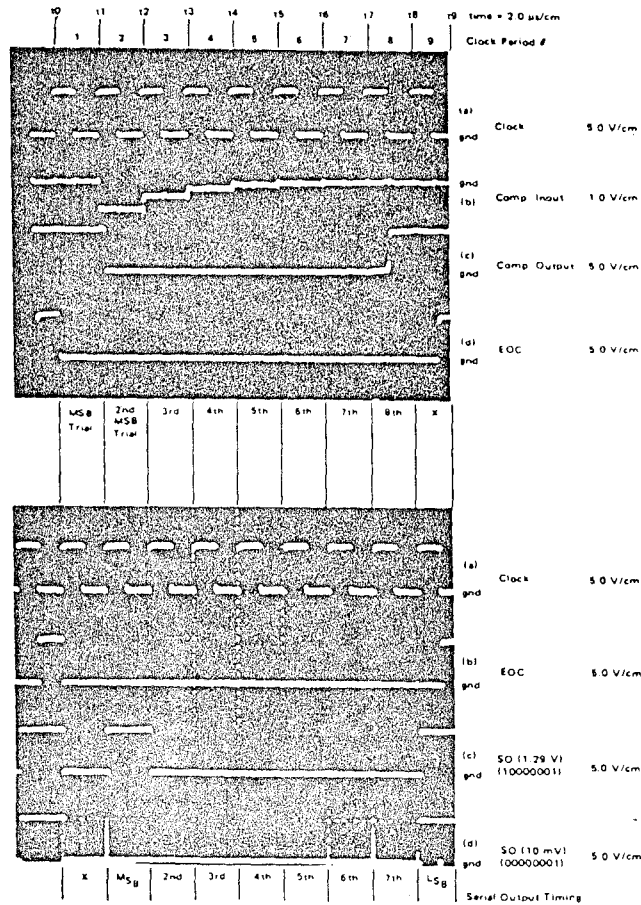

FIGURE 6 -

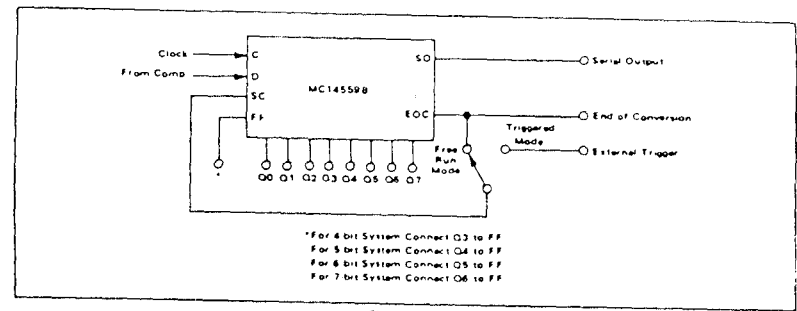

FIGURE 7 -

There are  $2^n$  possible digital words the A/D can give as an output, each representing one of the  $2^n$  discrete levels. Since there are no words in between these  $2^n$  words, a voltage that is between two levels must be represented by one or the other, usually the closest one. For example the actual value of the input voltage could be exactly halfway between two levels and the A/D would represent it with one or the other of the two words. In this case the system would be in error  $+1/2$  quantization unit if the upper level were read out, and  $-1/2$  quantization unit if the lower level were read out. The maximum error here is  $1/2$  quantization unit. In most A/D systems, and in particular this one, the quantization unit and the LSB are interchangeable. Given this, the S/A type of A/D has a built in quantization error of  $\pm 1/2$  LSB.

The digital-to-analog converter gives an analog output dependent upon the reference and the digital word on its inputs. The accuracy of the D/A depends on how closely the actual analog output of the D/A matches the ideal value described by the reference and the digital word input. In order for a D/A to be  $n$ -bit accurate, the analog output must not deviate from the ideal value by more than  $\pm 1/2$  of the least significant bit. The value of the LSB is  $1/2^n$  of reference.

The comparator is essentially a linear device and as such has a certain amount of voltage gain. If the voltage gain of the device is anything less than infinity, the differential input voltage required to switch the comparator output from one state to the other, call it  $V_d$ , is greater than zero. The value of  $V_d$  is simply the logic swing of the comparator divided by the open loop gain. If the differential input voltage to the comparator is less than  $V_d$ , the comparator's output cannot be guaranteed to be a logic one or zero. If we say the threshold of the comparator is half way through this uncertainty region, then we must allow an error of up to  $V_d/2$  due to the comparator's finite gain.

There are three sources of offset voltage error in the system of Figure 3. One is the offset voltage of the input buffer amplifier. Another is the offset voltage of the

comparator and the third is misadjustment of the offset adjust pot.

The first two offset voltages mentioned are inherent in the devices used and are fixed, usually they are on the order of about  $\pm 2$  mV for commercial grade components. They are fixed and can be easily compensated for by the offset adjustment. Once they are adjusted for, one only need be concerned with their changing value due to temperature or age.

In practice, the settling time of the D/A is usually not a source of error. It is mentioned here only as a figure of caution because if the D/A is not given time to settle it can be a source of error. In D/A specifications, a figure of time is given for the D/A to settle to some specific amount of accuracy. This means that once the digital word on the input of the D/A has been changed, a certain minimum amount of time is required before the D/A's analog output can be guaranteed fall within given accuracy limits. Therefore when designing an S/A system, the clock period must be long enough to give the SAR and comparator time to function in addition to giving the D/A time to settle to the desired accuracy. Note also that all of these events are sequential. That is, the SAR must give the proper address to the D/A, then the D/A must be allowed to settle and then time must be allowed for the comparator to react. All this must be allowed to happen within one clock period.

Given the sources of error as explained earlier, let us now examine the circuit of Figure 3 and try to estimate the total system accuracy.

First of all, there is the quantization uncertainty of  $\pm 1/2$  LSB. In addition to this we must add the error due to the D/A converter. Usually a D/A has an error specification of  $\pm 1/2$  LSB, although it could be better or worse, depending on the D/A.

In this example (Figure 3) the MC1408L can be purchased with accuracy specs of 6, 7 or 8-bits. 8-bit accuracy implies error of no more than  $\pm 1/2$  of one part out of 256 or  $\pm$  one part in 512. So for an 8-bit system as shown, the D/A contributes a maximum of  $\pm 1/2$  LSB. Since the

quantization error and the D/A error are independent, worst case error is simply the sum of one LSB. In addition, there is the error contributed by the comparator and the input buffer. As stated earlier, the offset voltages of the input and the comparator can be zeroed by the offset adjust pot, therefore only the changes due to temperature and aging need be added. Typical offset voltage drifts of these components are on the order of  $5 \mu\text{V}/^\circ\text{C}$ . So except for very wide temperature changes these drifts may be neglected.

The error due to the finite voltage gain of the comparator is also negligible for standard components. The MLM301A has a typical voltage gain of 200,000. For a 5 volt logic swing the uncertainty region is on the order of  $25 \mu\text{V}$ . With an LSB magnitude of 10 mV, (full scale of 2.56 volts) and the  $\pm 1$  LSB error due to the A/D quantization and the D/A error, the error due to the comparator is virtually zero.

The offset adjust pot in the system does more than just zero out the offset voltages of the input buffer and comparator. The primary purpose of this adjustment is to offset the scale of the D/A output  $1/2$  LSB. The reason for this is quite straight forward. It can be seen that the output of the S/A type A/D system is always less than or equal to the input voltage. In some cases the output of the A/D can be exactly equal to the input voltage, while at other times it can be as much as one LSB low. (Quantization error). When the  $+1/2$  LSB error due to the D/A is added, we have a maximum system error of  $+1/2$  LSB  $-1/2$  LSB. In order to make the error of the A/D symmetrical we simply offset the reference input of the comparator a negative  $1/2$  LSB. (Offsetting the comparator a negative  $1/2$  LSB is identically equal to raising the D/A output waveform  $1/2$  LSB). Now the error of the A/D is  $\pm 1$  LSB.

#### USES OF THE S/A

The Successive Approximation type of A/D system has a myriad of applications in the medium speed, medium accuracy A/D converter category. There are several reasons for its wide usage. Among these are, constant conversion

time ( $n + 1$  clock periods), gives both a serial and parallel output, high speed-accuracy product, ease of implementation, and low cost.

In multiplexing applications, that is when the A/D system is being used for multiple input signals, constant conversion time is very desirable. Some A/D system's conversion times are dependent upon the value of the input signal. This is undesirable in a multiplexing application because the worst case (i.e., longest) conversion time must be allowed for each input. This infers a non-optimum use of hardware and decreases system performance. Since the S/A system gives a constant conversion time that is independent of the input voltage, optimum use may be made of the system's speed.

In a communications application where the A/D output is to be sent to another location, the serial output of the S/A system is a natural. Unless the user desires to run multiple data lines, one for each bit of the A/D, the output of an A/D used in this manner must be changed from a parallel output to a serial output before the information can be sent to a remote location. As the S/A system inherently gives the serial output, a savings in both hardware and cost can be achieved.

The S/A system gives a very high speed-accuracy product. When one considers the speeds achievable coupled with the accuracies obtainable for a given cost system, the S/A has no peers in this category. For example, using the S/A system, an 8-bit A/D conversion can easily be accomplished in less than  $5 \mu\text{s}$ , at a total cost of less than \$20. When these same parameters are considered for other types of A/D's such as the Cyclic, Tracking, Parallel etc; the speed-accuracy product for a given system cost is considerably less.

As mentioned earlier, the new monolithic D/A's and SAR's have not only drastically reduced system cost, power, and size, but have increased reliability and temperature performance as well. The successive approximation type of A/D system was very popular before these components were available. Now, with the addition of these MSI building blocks the S/A system can do nothing but become more popular and its field of usage expand.



MOTOROLA Semiconductor Products Inc.

AN746  
Application Note

## A $3\frac{1}{2}$ DIGIT DVM USING AN INTEGRATED CIRCUIT DUAL RAMP SYSTEM

Prepared by  
Don Aldridge  
Applications Engineering

This application note describes the design of a  $3\frac{1}{2}$ -digit DVM (digital voltmeter) using the MC1405 and the MC14435 dual ramp A/D system. The performance criteria is that of a lab quality DVM with both  $3\frac{1}{2}$ -digit resolution and accuracy while still retaining a low cost and low parts count instrument. Features of the DVM include circuitry for a high impedance input, autopolarity and overrange indication.



MOTOROLA Semiconductor Products Inc.

APPLICATIONS INFORMATION (continued)

FIGURE 31 - ANALOG PRODUCT OF TWO DIGITAL WORDS (High-Speed Operation)

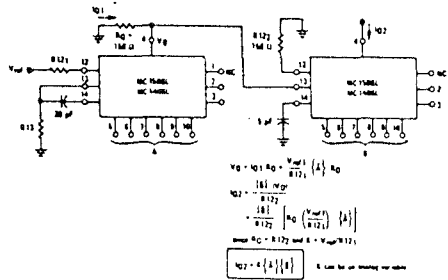

Two Digit BCD Conversion

MC1506L parts which meet the specification for 7 bit accuracy can be used for the most significant word when building a two digit BCD D-to-A or A-to-D converter. If both outputs feed the virtual ground of an operational amplifier, 10:1 current scaling can be achieved with a resistive current divider. If current output is desired, the units may be operated at full scale current levels of 4.0 mA and 0.4 mA with the outputs connected to sum the currents. The error of the D-to-A converter handling the least significant bits will be scaled down by a factor of ten.

FIGURE 32 - DIGITAL QUOTIENT OF TWO ANALOG VARIABLES or ANALOG-TO-DIGITAL CONVERSION

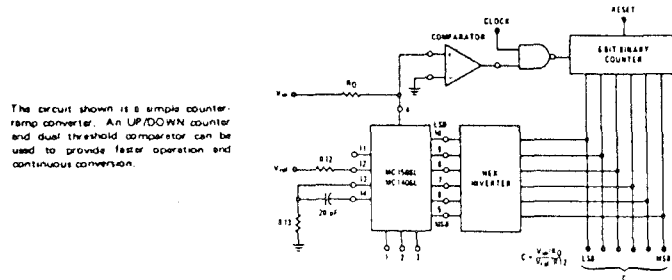

The circuit shown is a simple counter-ramp converter. An UP/DOWN counter and dual threshold comparator can be used to provide faster operation and continuous conversion.

Circuit diagrams utilizing Motorola products are included as a means of illustrating typical semiconductor applications; consequently, complete information sufficient for construction purposes is not necessarily given. The information has been carefully checked and

is believed to be entirely reliable. However, no responsibility is assumed for inaccuracies. Furthermore, such information does not convey to the purchaser of the semiconductor devices described any license under the patent rights of Motorola Inc. or others.



MOTOROLA Semiconductor Products Inc.

OUTLINE DIMENSIONS

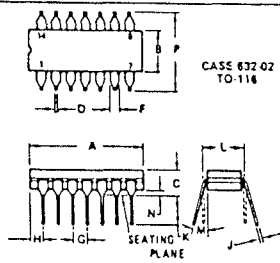

CASE 832 02 TO-118

Weight = 1.254 gms  
DIMENSION "L" TO CENTER OF LEADS WHEN FORMED PARALLEL.

All JEDEC dimensions and notes apply.

DIM	MILLIMETERS		INCHES	
	MIN	MAX	MIN	MAX
A	16.8	19.3	0.660	0.765
B	5.59	7.11	0.220	0.280
C	-	5.98	-	0.235
D	0.381	0.584	0.015	0.023
F	0.27	1.27	0.030	0.070
G	2.54 BSC	-	0.100 BSC	-
J	0.203	0.381	0.008	0.015
K	2.54	-	0.100	-
L	7.67 BSC	-	0.300 BSC	-
M	-	1.53	-	0.060
N	0.51	0.75	0.020	0.030
P	-	1.25	-	0.125



MOTOROLA Semiconductors

Specifications and Applications Information

EIGHT-BIT MULTIPLYING DIGITAL-TO-ANALOG CONVERTER

designed for use where the output current is a linear product of an eight bit digital word and an analog input voltage.

- Relative Accuracy  $\pm 0.1\%$  Error maximum (MC1508L-8, MC1408L-8)
- Seven and Six Bit Accuracy Available (MC1408L-7, MC1408L-6)
- Fast Settling Time - 300 ns typical
- Noninverting Digital Inputs are TTL and CMOS Compatible
- Output Voltage Swing - +0.4 V to -5.0 V
- High Speed Multiplying Input Slew Rate 4.0 mA/us
- Standard Supply Voltages +5.0 V and -5.0 V to -15 V

MC1508L-8  
MC1408L-8  
MC1408L-7  
MC1408L-6

EIGHT-BIT MULTIPLYING DIGITAL-TO-ANALOG CONVERTER

SILICON MONOLITHIC INTEGRATED CIRCUIT



TO-118 CERAMIC PACKAGE CASE 820

FIGURE 1 - D to A TRANSFER CHARACTERISTICS

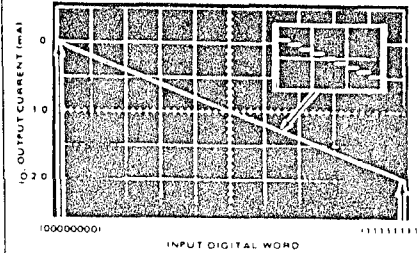
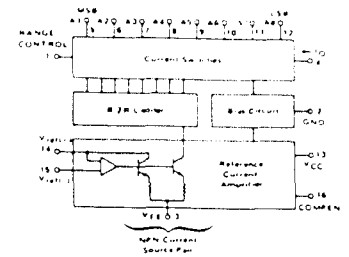

FIGURE 2 - BLOCK DIAGRAM



TYPICAL APPLICATIONS

- Tracking A to D Converters
- Successive Approximation A to D Converters
- 2 1/2 Digit Panel Meters and DVM's
- Waveform Synthesis
- Sample and Hold
- Peak Detector
- Programmable Gain and Attenuation
- CRT Character Generation
- Audio Digitizing and Decoding
- Programmable Power Supplies
- Analog Digital Multiplication
- Digital Digital Multiplication
- Analog Digital Division
- Digital Addition and Subtraction
- Speech Compression and Expansion
- Stepping Motor Drive

MTTL is a trademark of Motorola Inc.

© MOTOROLA INC. 1975

DS 9238 \*1

MAXIMUM RATINGS (T<sub>A</sub> = +25°C unless otherwise noted)

Rating	Symbol	Value	Unit
Power Supply Voltage	V <sub>CC</sub> V <sub>EE</sub>	+5.5 -16.5	V <sub>dc</sub>
Digital Input Voltage	V <sub>I</sub> thru V <sub>I12</sub>	0 to +5.5	V <sub>dc</sub>
Applied Output Voltage	V <sub>O</sub>	+0.5, -5.2	V <sub>dc</sub>
Reference Current	I <sub>14</sub>	5.0	mA
Reference Amplifier Inputs	V <sub>14</sub> , V <sub>15</sub>	V <sub>CC</sub> , V <sub>EE</sub>	V <sub>dc</sub>
Operating Temperature Range	T <sub>A</sub>	-55 to +125	°C
	MC1508LB MC1408L Series	0 to +75	
Storage Temperature Range	T <sub>stg</sub>	-65 to +150	°C

ELECTRICAL CHARACTERISTICS (V<sub>CC</sub> = +5.0 V<sub>dc</sub>, V<sub>EE</sub> = -15 V<sub>dc</sub>, I<sub>ref</sub> = 2.0 mA, MC1508LB T<sub>A</sub> = -55°C to +125°C, MC1408L Series T<sub>A</sub> = 0 to +75°C unless otherwise noted. All digital inputs at high logic level.)

Characteristic	Figure	Symbol	Min	Typ	Max	Unit
Relative Accuracy (Error relative to full scale (%)) MC1508LB, MC1408LB MC1408L: See Note 1 MC1408LB: See Note 1	4	E <sub>r</sub>	-	-	±0.19 ±0.39 ±0.78	%
Settling Time to within ±1/2 LSB (includes t <sub>PLH</sub> ) (T <sub>A</sub> = +25°C) See Note 2	5	t <sub>S</sub>	-	300	-	ns
Propagation Delay Time T <sub>A</sub> = +25°C	5	t <sub>PLH</sub> , t <sub>PHL</sub>	-	30	100	ns
Output Full Scale Current Drift		TC <sub>IO</sub>	-	-20	-	PPM/°C
Digital Input Logic Levels (MSB) High Level, Logic "1" Low Level, Logic "0"	3	V <sub>IH</sub> V <sub>IL</sub>	2.0 -	-	-	V <sub>dc</sub>
Digital Input Current (MSB) High Level, V <sub>IH</sub> = 5.0 V Low Level, V <sub>IL</sub> = 0.8 V	3	I <sub>IH</sub> I <sub>IL</sub>	-	0 -0.4	0.04 -0.8	mA
Reference Input Bias Current (Pin 15)	3	I <sub>15</sub>	-	-1.0	-5.0	µA
Output Current Range V <sub>EE</sub> = -5.0 V V <sub>EE</sub> = -15 V, T <sub>A</sub> = 25°C	3	I <sub>OR</sub>	0 0	2.0 2.0	2.1 4.2	mA
Output Current V <sub>ref</sub> = 2.000 V, R <sub>14</sub> = 1000 Ω	3	I <sub>O</sub>	1.9	1.99	2.1	mA
Output Current (All bits low)	3	I <sub>O(min)</sub>	-	0	4.0	µA
Output Voltage Compliance (E <sub>r</sub> ≤ 0.19% at T <sub>A</sub> = +25°C) Pin 1 grounded Pin 1 open, V <sub>EE</sub> below -10 V	3	V <sub>O</sub>	-	-	0.55, +0.4 -5.0, +0.4	V <sub>dc</sub>
Reference Current Slew Rate	6	SR I <sub>ref</sub>	-	4.0	-	mA/µs
Output Current Power Supply Sensitivity		PSRR <sub>I</sub> -1	-	0.5	2.7	µA/V
Power Supply Current (All bits low)	3	I <sub>CC</sub> I <sub>EE</sub>	-	+13.5 -7.5	+22 -13	mA
Power Supply Voltage Range (T <sub>A</sub> = +25°C)	3	V <sub>CCR</sub> V <sub>VEER</sub>	+4.5 -4.5	+5.0 -15	+5.5 -16.5	V <sub>dc</sub>
Power Dissipation All bits low V <sub>EE</sub> = -5.0 V <sub>dc</sub> V <sub>EE</sub> = -15 V <sub>dc</sub> All bits high V <sub>EE</sub> = -5.0 V <sub>dc</sub> V <sub>EE</sub> = -15 V <sub>dc</sub>	3	P <sub>D</sub>	-	105 190	170 305	mW

Note 1: All current switches are tested to guarantee at least 50% of rated output current.  
Note 2: All bits switched.



MOTOROLA Semiconductor Products Inc.

TEST CIRCUITS

FIGURE 3 - NOTATION DEFINITIONS TEST CIRCUIT

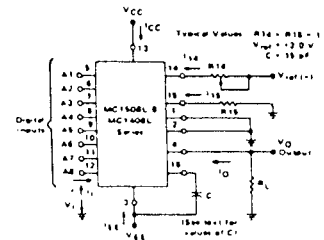

V<sub>1</sub> and I<sub>1</sub> apply to inputs A1 thru A8.

The resistor tied to pin 15 is to temperature compensate the bias current and may not be necessary for all applications.

$$I_O = K \left( \frac{A_1}{2} + \frac{A_2}{4} + \frac{A_3}{8} + \frac{A_4}{16} + \frac{A_5}{32} + \frac{A_6}{64} + \frac{A_7}{128} + \frac{A_8}{256} \right)$$

where  $K = \frac{V_{ref}}{R_{14}}$

and A<sub>N</sub> = 1 if A<sub>N</sub> is at high level  
A<sub>N</sub> = 0 if A<sub>N</sub> is at low level

FIGURE 4 - RELATIVE ACCURACY TEST CIRCUIT

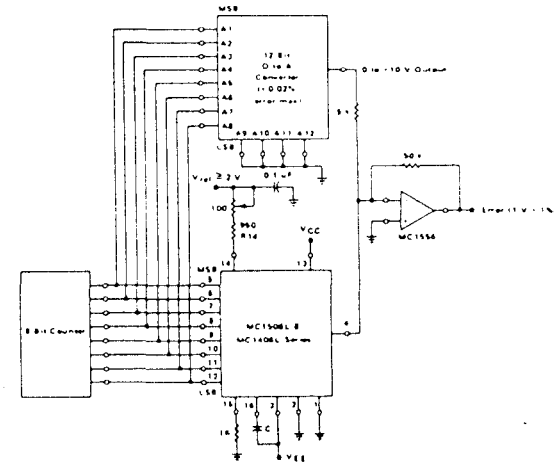
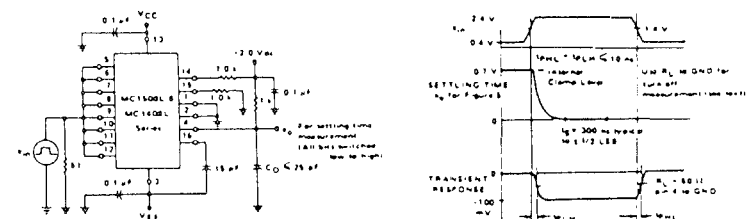

FIGURE 5 - TRANSIENT RESPONSE AND SETTLING TIME



MOTOROLA Semiconductor Products Inc.

TEST CIRCUITS (continued)

FIGURE 6 - REFERENCE CURRENT SLEW RATE MEASUREMENT

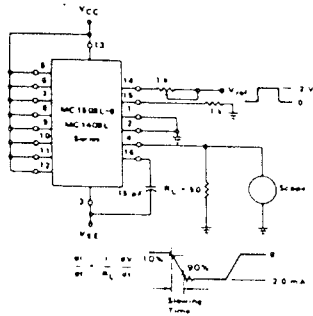

FIGURE 7 - POSITIVE Vref

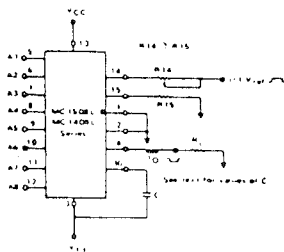
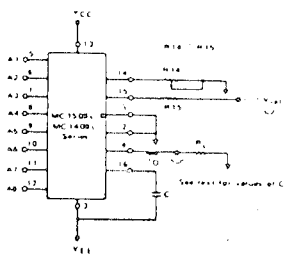

FIGURE 8 - NEGATIVE Vref



THERMAL INFORMATION

The maximum power consumption an integrated circuit can tolerate at a given operating ambient temperature, can be found from the equation:

$$P_{D(T_A)} = \frac{T_{J(max)} - T_A}{R_{\theta JA(Typ)}}$$

Where  $P_{D(T_A)}$  = Power Dissipation allowable at a given operating ambient temperature. This must be greater than the sum of the products of the supply voltages and supply currents at the worst case operating condition.

- $T_{J(max)}$  = Maximum Operating Junction Temperature as listed in the Maximum Ratings Section
- $T_A$  = Maximum Desired Operating Ambient Temperature
- $R_{\theta JA(Typ)}$  = Typical Thermal Resistance Junction to Ambient

OUTLINE DIMENSIONS

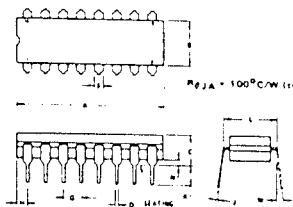

- 1 LEADS WITHIN 0.13 = 18.000 RADIIUS OF FACE POSITION AT SEATING PLANE AT MAXIMUM MATERIAL CONDITION
- 2 PEG INDEX NOTCH IN LEAD NOTCH IN CERAMIC OR IN DOT
- 3 DIM. 1 TO CENTER OF LEADS WHEN FORMED PARALLEL

Weight: 1.193 grams

DIM	MILLIMETERS		INCHES	
	MIN	MAX	MIN	MAX
A	19.0	19.81	0.750	0.780
B	6.71	6.88	0.264	0.275
C	4.08	3.28	0.160	0.129
D	8.90	8.91	0.350	0.350
E	1.42	1.85	0.055	0.074
F	7.54	8.52	0.297	0.335
G	8.51	8.74	0.335	0.344
H	2.78	3.31	0.109	0.131
K	3.18	3.30	0.125	0.130
L	3.32	3.33	0.130	0.130
M	1.01	1.01	0.039	0.039
N	6.52	6.92	0.257	0.273

CASE 620-02  
CERAMIC PACKAGE



MOTOROLA Semiconductor Products Inc.

FIGURE 9 - MC1508L-9/MC1408L-8 SERIES EQUIVALENT CIRCUIT SCHEMATIC DIGITAL INPUTS

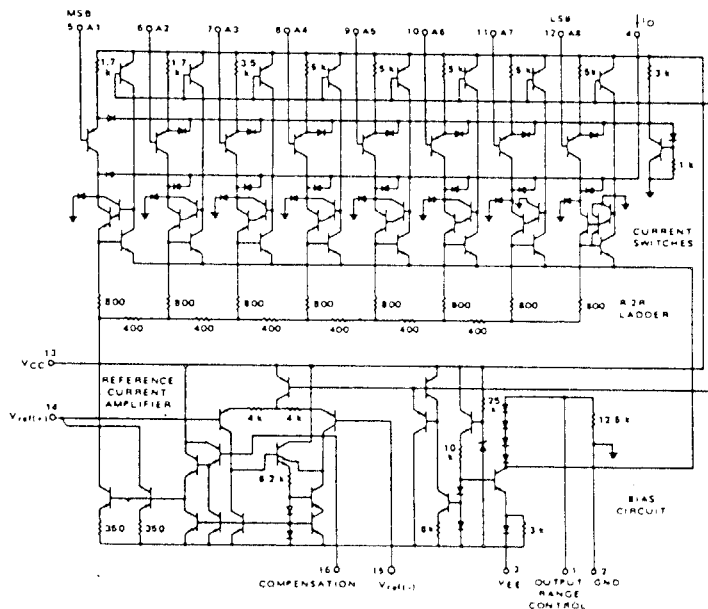

CIRCUIT DESCRIPTION

The MC1508L-9 consists of a reference current amplifier, an R-2R ladder, and eight high speed current switches. For many applications, only a reference resistor and reference voltage need be added.

The switches are noninverting in operation, therefore a high state on the input turns on the specified output current component. The switch uses current steering for high speed, and a termination amplifier consisting of an active load gain stage with unity gain feedback. The termination amplifier holds the parasitic capacitance of the ladder at a constant voltage during switching, and provides

a low impedance termination of equal voltage for all legs of the ladder.

The R-2R ladder divides the reference amplifier current into binary related components, which are fed to the switches. Note that there is always a remainder current which is equal to the least significant bit. This current is shunted to ground, and the maximum output current is 255/256 of the reference amplifier current, or 1.992 mA for a 2.0 mA reference amplifier current if the NPN current source pair is perfectly matched.



MOTOROLA Semiconductor Products Inc.

GENERAL INFORMATION

Reference Amplifier Drive and Compensation

The reference amplifier provides a voltage at pin 14 for compensating the reference voltage to current, and a turn-around circuit or current mirror for loading the ladder. The reference amplifier input current, I<sub>14</sub>, must always flow into pin 14 regardless of the setup method or reference voltage polarity.

Connections for a positive reference voltage are shown in Figure 7. The reference voltage source supplies the full current I<sub>14</sub>. For bipolar reference signals, as in the multiplying mode, R15 can be tied to a negative voltage corresponding to the minimum input level. It is possible to eliminate R15 with only a small sacrifice in accuracy and temperature drift. Another method for bipolar inputs is shown in Figure 25.

The compensation capacitor value must be increased with increases in R14 to maintain proper phase margin. For R14 values of 1.0, 2.5 and 5.0 kilohms, minimum capacitor values are 15, 37, and 75 pF. The capacitor should be tied to V<sub>EE</sub> as this increases negative supply rejection.

A negative reference voltage may be used if R14 is grounded and the reference voltage is applied to R15 as shown in Figure 8. A high input impedance is the main advantage of this method. Compensation involves a capacitor to V<sub>EE</sub> on pin 18, using the values of the previous paragraph. The negative reference voltage must be at least 3.0 volts above the V<sub>EE</sub> supply. Bipolar input signals may be handled by connecting R14 to a positive reference voltage equal to the peak positive input level at pin 15.

When a dc reference voltage is used, capacitive bypass to ground is recommended. The 5.0 V logic supply is not recommended as a reference voltage. If a well regulated 5.0 V supply which drives logic is to be used as the reference, R14 should be decoupled by connecting it to +5.0 V through another resistor and bypassing the junction of the two resistors with 0.1 μF to ground. For reference voltages greater than 5.0 V, a clamp diode is recommended between pin 14 and ground.

If pin 14 is driven by a high impedance such as a transistor current source, none of the above compensation methods apply and the amplifier must be heavily compensated, decreasing the overall bandwidth.

Output Voltage Range

The voltage on pin 4 is restricted to a range of -0.55 to +0.4 volts at +25°C, due to the current switching methods employed in the MC1508L-B. When a current switch is turned "off", the positive voltage on the output terminal can turn "on" the output diode and increase the output current level. When a current switch is turned "on", the negative output voltage range is restricted. The base of the termination circuit Darlington transistor is one diode voltage below ground when pin 1 is grounded, so a negative voltage below the specified safe level will drive the low current device of the Darlington into saturation, decreasing the output current level.

The negative output voltage compliance of the MC1508L-B may be extended to -5.0 V volts by opening the circuit at pin 1. The negative supply voltage must be more negative than -10 volts. Using a full scale current of 1.992 mA and load resistor of 2.5 kilohms between pin 4 and ground will yield a voltage output of 256 levels between 0 and -4.980 volts. Floating pin 1 does not affect the converter speed or power dissipation. However, the value of the load resistor determines the switching time due to increased voltage swing. Values of R<sub>L</sub> up to 500 ohms do not significantly affect performance, but a 2.5 kilohm load increases "worst case" settling time to 1.2 μs (when all bits are switched on).

Refer to the subsequent test section on Settling Time for more detail on output loading.

If a power supply value between -5.0 V and -1.0 V is desired, a voltage of between 0 and -5.0 V may be applied to pin 1. The value of this voltage will be the maximum allowable negative output swing.

Output Current Range

The output current maximum rating of 4.2 mA may be used only for negative supply voltages (typically more negative than -8.0 volts, due to the increased voltage drop across the 350-ohm resistors in the reference current amplifier).

Accuracy

Absolute accuracy is the measure of each output current level with respect to its intended value, and it depends upon relative accuracy and full scale current drift. Relative accuracy is the measure of each output current level as a fraction of the full scale current. The relative accuracy of the MC1508L-B is essentially constant with temperature due to the excellent temperature tracking of the monolithic resistor ladder. The reference current may drift with temperature, causing a change in the absolute accuracy of output current. However, the MC1508L-B has a very low full scale current drift with temperature.

The MC1508L-B/MC1408L Series is guaranteed accurate to within ±1/2 LSB at +25°C at a full scale output current of 1.992 mA. This corresponds to a reference amplifier output current drive to the ladder network of 2.0 mA, with the loss of one LSB = 8.0 μA which is the ladder remainder shunted to ground. The input current to pin 14 has a guaranteed value of between 1.9 and 2.1 mA, allowing some mismatch in the NPN current source pair. The accuracy test circuit is shown in Figure 4. The 12-bit converter is calibrated for a full scale output current of 1.992 mA. This is an optional step since the MC1508L-B accuracy is essentially the same between 1.5 and 2.5 mA. Then the MC1508L-B circuit's full scale current is trimmed to the same value with R14 so that a zero value appears at the error amplifier output. The counter is activated and the error band may be displayed on an oscilloscope, detected by comparators, or stored in a peak detector.

Two 8-bit D-to-A converters may not be used to construct a 16-bit accurate D-to-A converter. 16-bit accuracy implies a total error of ±1/2 of one part in 65,536, or ±0.00076%, which is much more accurate than the ±0.1% specification provided by the MC1508L-B.

Multiplying Accuracy

The MC1508L-B may be used in the multiplying mode with eight bit accuracy when the reference current is varied over a range of 256:1. The major source of error is the bias current of the termination amplifier. Under "worst case" conditions, these eight amplifiers can contribute a total of 16 μA extra current at the output terminal. If the reference current in the multiplying mode ranges from 16 μA to 4.0 mA, the 16 μA contributes an error of 0.1 LSB. This is well within eight-bit accuracy referenced to 4.0 mA.

A monotonic converter is one which supplies an increase in current for each increment in the binary word. Typically, the MC1508L-B is monotonic for all values of reference current above 0.5 mA. The recommended range for operation with a dc reference current is 0.5 to 4.0 mA.

GENERAL INFORMATION (Continued)

Settling Time

The "worst case" switching condition occurs when all bits are switched "on", which corresponds to a low-to-high transition for all bits. This time is typically 300 ns for settling to within ±1/2 LSB for 8 bit accuracy, and 200 ns to 1/2 LSB for 7 and 6 bit accuracy. The turn off is typically under 100 ns. These times apply when R<sub>L</sub> < 500 ohms and C<sub>0</sub> < 25 pF.

The slowest single switch is the least significant bit, which turns "on" and settles in 250 ns and turns "off" in 80 ns. In applications where the D-to-A converter functions in a positive going ramp mode, the "worst case" switching condition does not occur, and a settling time of less than 300 ns may be realized. Bit A7 turns "on" in 200 ns and "off" in 80 ns, while bit A6 turns "on" in 150 ns and "off" in 80 ns.

TYPICAL CHARACTERISTICS

(V<sub>CC</sub> = +5.0 V, V<sub>EE</sub> = -15 V, T<sub>A</sub> = +25°C unless otherwise noted.)

FIGURE 10 - LOGIC INPUT CURRENT versus INPUT VOLTAGE

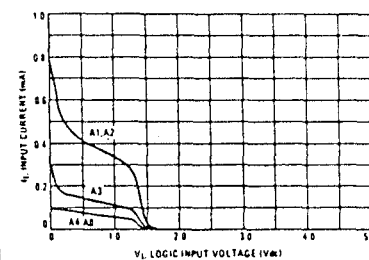

FIGURE 11 - TRANSFER CHARACTERISTIC versus TEMPERATURE (A5 thru A8 thresholds lie within range for A1 thru A4)

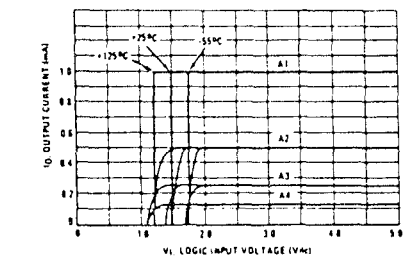

FIGURE 12 - OUTPUT CURRENT versus OUTPUT VOLTAGE (See test for pin 1 restrictions)

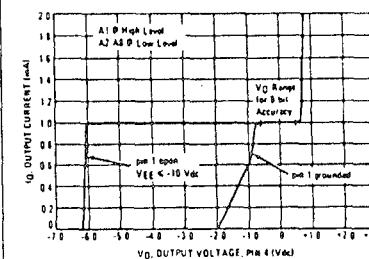
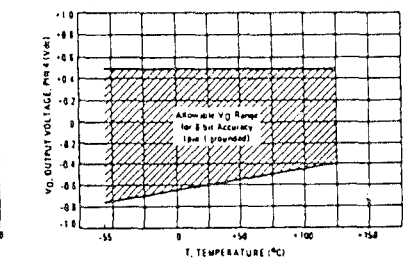

FIGURE 13 - OUTPUT VOLTAGE versus TEMPERATURE (Negative range with pin 1 open at -5.0 Vdc over full temperature range)



MOTOROLA Semiconductor Products Inc.



MOTOROLA Semiconductor Products Inc.

TYPICAL CHARACTERISTICS (continued)  
 $V_{CC} = +5.0\text{ V}$ ,  $V_{EE} = -15\text{ V}$ ,  $T_A = +25^\circ\text{C}$  unless otherwise noted

FIGURE 14 - REFERENCE INPUT FREQUENCY RESPONSE

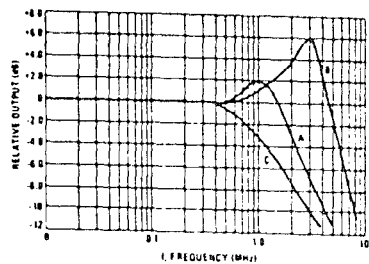

Unless otherwise specified:  
 $R_{14} = 815 - 10 \times 11$   
 $C = 15\text{ pF}$ , pin 16 to  $V_{EE}$   
 $R_4 = 50\text{ k}\Omega$ , pin 4 to GND

Curve A: Large Signal Bandwidth  
 Method of Figure 7  
 $V_{ref} = 2.2\text{ V}$  of offset 1.0 V above GND

Curve B: Small Signal Bandwidth  
 Method of Figure 7,  $R_L = 250\text{ }\Omega$   
 $V_{ref} = 50\text{ mV}$  of offset 200 mV above GND

Curve C: Large and Small Signal Bandwidths  
 Method of Figure 7, low and high,  $R_L = 50\text{ }\Omega$   
 $V_{ref} = 2.0\text{ V}$   
 $V_{EE} = 100\text{ mV}$  of offset at 0 V

FIGURE 15 - TYPICAL POWER SUPPLY CURRENT versus TEMPERATURE (all bits low)

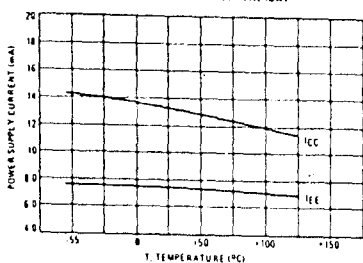
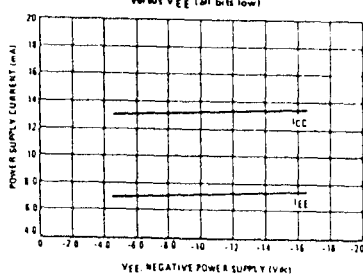
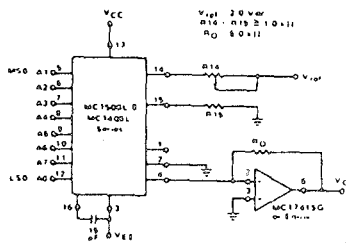

FIGURE 16 - TYPICAL POWER SUPPLY CURRENT versus  $V_{EE}$  (all bits low)



APPLICATIONS INFORMATION

FIGURE 17 - OUTPUT CURRENT TO VOLTAGE CONVERSION



Theoretical  $V_O$

$$V_O = \frac{V_{ref}}{R_{14}} \left[ \frac{A_1}{2} + \frac{A_2}{6} + \frac{A_3}{8} + \frac{A_4}{16} + \frac{A_5}{32} + \frac{A_6}{64} + \frac{A_7}{128} + \frac{A_8}{256} \right]$$

Adjust  $V_{ref}$ ,  $R_{14}$  or  $R_{10}$  so that  $V_O$  with all digital inputs at high level is equal to 0.001 volts

$$V_O = \frac{2\text{ V}}{14} \left[ \frac{1}{2} + \frac{1}{6} + \frac{1}{8} + \frac{1}{16} + \frac{1}{32} + \frac{1}{64} + \frac{1}{128} + \frac{1}{256} \right]$$

$$10\text{ V} \left[ \frac{256}{256} \right] = 0.001\text{ V}$$

APPLICATIONS INFORMATION (continued)

Voltage outputs of a larger magnitude are obtainable with this circuit which uses an external operational amplifier as a current to voltage converter. This configuration automatically keeps the output of the MC1508L-8 at ground potential and the operational amplifier can generate a positive voltage limited only by its positive supply voltage. Frequency response and settling time are primarily determined by the characteristics of the operational amplifier. In addition, the operational amplifier must be compensated for unity gain, and in some cases overcompensation may be desirable.

Note that this configuration results in a positive output voltage only. The magnitude of which is dependent on the digital input. The following circuit shows how the LM301AG can be used in a feedforward mode resulting in a full scale settling time on the order of 20  $\mu\text{s}$ .

FIGURE 18

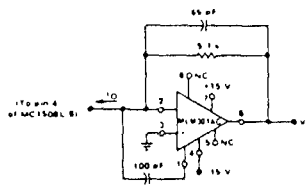

An alternative method is to use the MC1590C and input compensation. Response of this circuit is also on the order of 20  $\mu\text{s}$ . See Motorola Application Note AN-459 for more details on this concept.

FIGURE 19

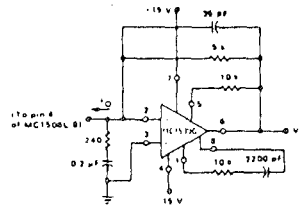

The positive voltage range may be extended by cascading the output with a high beta common base transistor, Q1, as shown.

FIGURE 20 - EXTENDING POSITIVE VOLTAGE RANGE

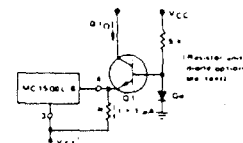

The output voltage range for this circuit is 0 volts to  $BVC_{BO}$  of the transistor. If pin 1 is left open, the transistor base may be grounded, eliminating both the resistor and the diode. Variations in beta must be considered for wide temperature range applications. An inverted output waveform may be obtained by using a load resistor from a positive reference voltage to the collector of the transistor. Also, high speed operation is possible with a large output voltage swing, because pin 4 is held at a constant voltage. The resistor (R1) to  $V_{EE}$  maintains the transistor emitter current when all bits are "off" and insures fast turn-on of the least significant bit.

Combined Output Amplifier and Voltage Reference

For many of its applications the MC1508L-8 requires reference voltage and an operational amplifier. Normally the operational amplifier is used as a current to voltage converter and its output need only go positive. With the popular MC1723G voltage inputs for both of these functions are provided in a single package with the added bonus of up to 150 mA of output current. See Figure 21. The MC1723G uses both a positive and negative power supply. The reference voltage of the MC1723G is then developed with respect to the negative voltage and appears as a common mode signal to the reference amplifier in the D to A converter. This allows use of its output amplifier as a classic current to voltage converter with the non-inverting input grounded.

Since  $\pm 15\text{ V}$  and  $\pm 5.0\text{ V}$  are normally available in a combination digital to analog system, only the  $-5.0\text{ V}$  need be developed. A resistor divider is sufficiently accurate since the allowable range on pin 5 is from  $-2.0$  to  $-8.0$  volts. The  $5.0\text{ }\mu\text{A}$  output current on the amplifier output is necessary for fast negative transitions.

Full scale output may be increased to as much as 32 volts by increasing  $R_{10}$  and raising the  $\pm 15\text{ V}$  supply voltage to 35 V maximum. The resistor divider should be altered to comply with the maximum limit of 40 volts across the MC1723G.  $C_{10}$  may be decreased to maintain the same  $R_{10}C_{10}$  product if maximum speed is desired.

Preliminary

# Z8300 Low Power Z80L<sup>®</sup> CPU Central Processing Unit



## Product Specification

December 1981

### Features

- The Z80L combines the high performance of the Z80 CPU with extremely low power consumption. It has the identical pinout and instruction set of the Z80. The result is increased reliability and lower system power requirements. This dramatic power savings makes the Z80L a natural choice for both hand-held and battery backup applications.
- The Z80L CPU is offered in three versions:  
Z8300-1—1.0 MHz clock, 15 mA typical current consumption  
Z8300-2—1.5 MHz clock, 20 mA typical current consumption  
Z8300-3—2.5 MHz clock, 25 mA typical current consumption
- The extensive instruction set contains 158 instructions, resulting in sophisticated data handling capabilities. The 78 instructions of the 8080A are included as a subset; 8080A and Z80 Family software compatibility is maintained.
- The Z80L microprocessors and associated family of peripheral controllers are linked by a vectored interrupt system. This system may be daisy-chained to allow implementation of a priority interrupt scheme. Little, if any, additional logic is required for daisy chaining.
- Duplicate sets of both general-purpose and flag registers are provided, easing the design and operation of system software. Two 16-bit index registers facilitate program processing of tables and arrays.
- There are three modes of high-speed interrupt processing: 8080 compatible, non-Z80 peripheral device, and Z80 Family peripheral with or without daisy chain.
- On-chip dynamic memory refresh counter.

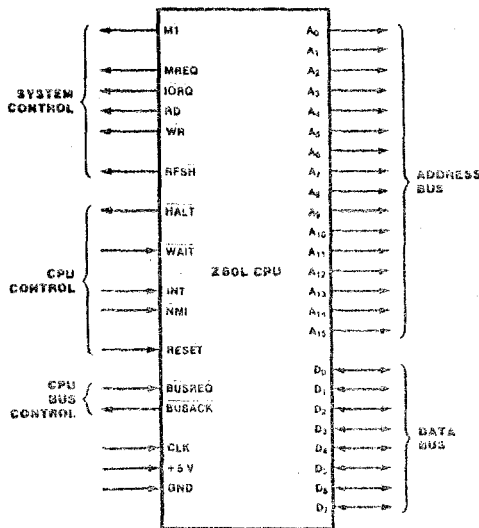

Figure 1. Pin Functions

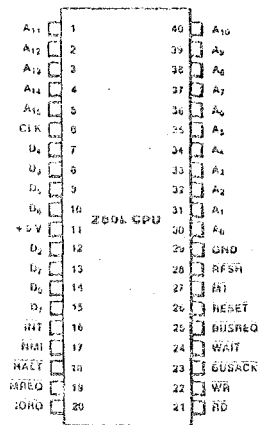

Figure 2. Pin Assignments

# Z8420 Z80<sup>®</sup> PIO Parallel Input/Output Controller



## Product Specification

December 1980

- Features**
- Provides a direct interface between Z-80 microcomputer systems and peripheral devices.
  - Both ports have interrupt-driven handshake for fast response.
  - Four programmable operating modes: byte input, byte output, byte input/output (Port A only), and bit input/output.

- Programmable interrupts on peripheral status conditions.
- Standard Z-80 Family bus-request and prioritized interrupt-request daisy chains implemented without external logic.
- The eight Port B outputs can drive Darlington transistors (1.5 mA at 1.5 V).

**General  
Description**

The Z-80 PIO Parallel I/O Circuit is a programmable, dual-port device that provides a TTL-compatible interface between peripheral devices and the Z-80 CPU. The CPU configures the Z-80 PIO to interface with a wide range of peripheral devices with no other external logic. Typical peripheral devices that are compatible with the Z-80 PIO include most keyboards, paper tape readers and punches, printers, PROM programmers, etc.

One characteristic of the Z-80 peripheral controllers that separates them from other interface controllers is that all data transfer between the peripheral device and the CPU is

accomplished under interrupt control. Thus, the interrupt logic of the PIO permits full use of the efficient interrupt capabilities of the Z-80 CPU during I/O transfers. All logic necessary to implement a fully nested interrupt structure is included in the PIO.

Another feature of the PIO is the ability to interrupt the CPU upon occurrence of specified status conditions in the peripheral device. For example, the PIO can be programmed to interrupt if any specified peripheral alarm conditions should occur. This interrupt capability reduces the time the processor must spend in polling peripheral status.

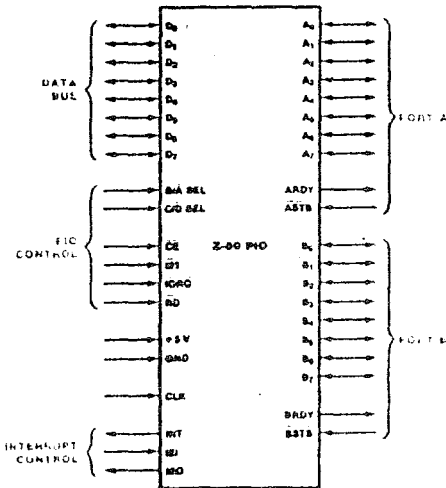

Figure 1. Pin Functions

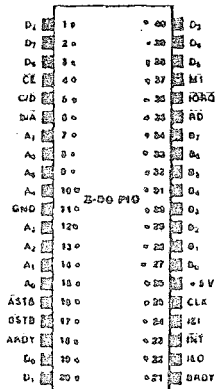
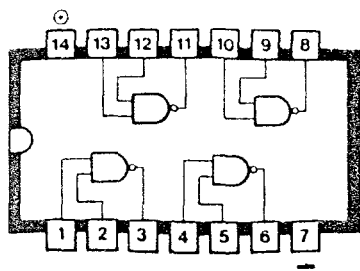

Figure 2. Pin Assignments

QUADRUPLE 2 INPUT NAND GATES

7400  
7403 open collector outputs  
7407 power driver (fan out = 30)



QUADRUPLE 2 INPUT NAND GATE WITH OPEN COLLECTOR OUTPUT

7401

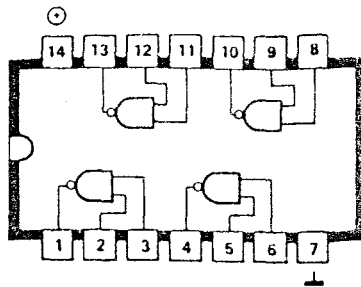

QUADRUPLE 2 INPUT NOR GATES

7402  
7428 power driver (fan out = 30)

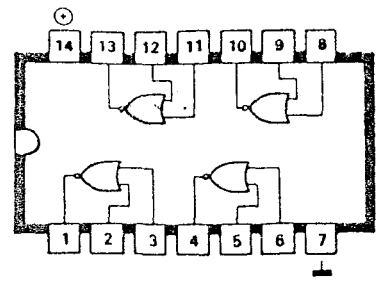

HEX INVERTERS

7404  
7406 open collector outputs  
7406 open collector high voltage outputs (max 30 V, fan out = 25)  
7416 open collector high voltage outputs (max 30 V, fan out = 25)

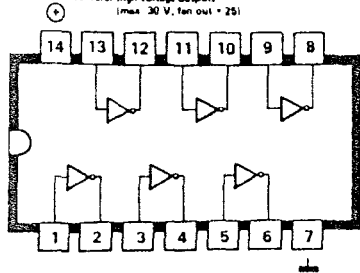

HEX BUFFER/DRIVER WITH OPEN COLLECTOR HIGH VOLTAGE OUTPUTS (max 30 V, fan out = 25)

7407

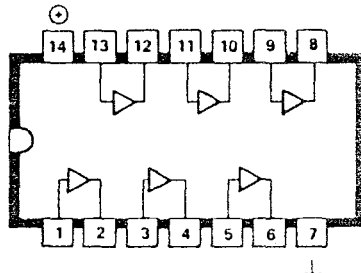

QUADRUPLE 2 INPUT AND GATES

7408  
7408 open collector outputs

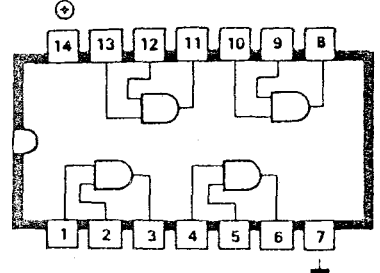

TRIPLE 3 INPUT NAND GATES

7410  
7412 open collector outputs

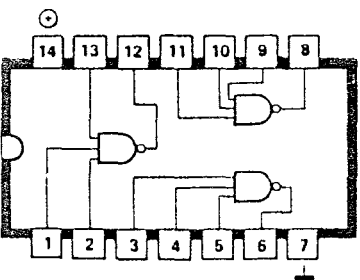

TRIPLE 3 INPUT AND GATE

7411

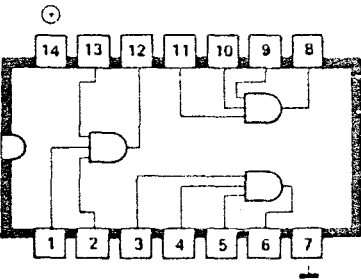

DUAL 4 INPUT NAND SCHMITT TRIGGER

7413

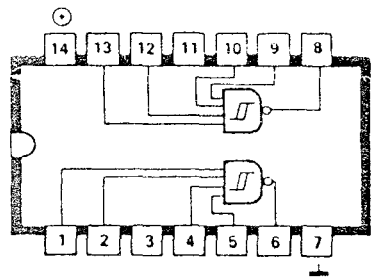

HEX SCHMITT TRIGGER INVERTER

7414

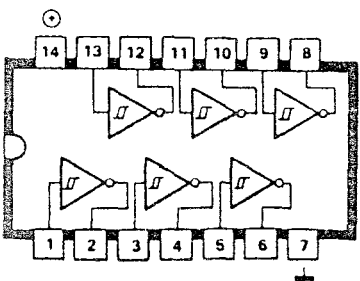

DUAL 4 INPUT NAND GATES

7420  
7440 power driver (fan out = 30)

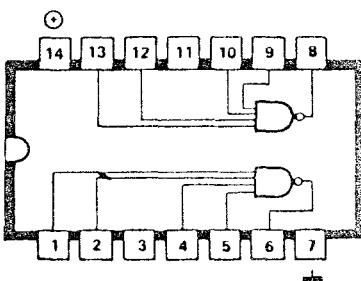

8 INPUT NAND GATE

7430

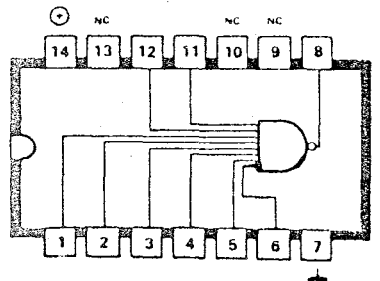

BCD TO DECIMAL DECODER-DRIVER WITH OPEN COLLECTOR OUTPUTS (max 30 V)

7445

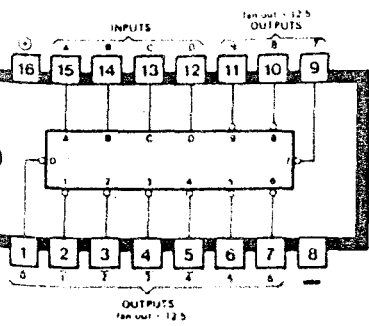

11-1 TO 7 SEGMENT DECODER/DRIVER

7447

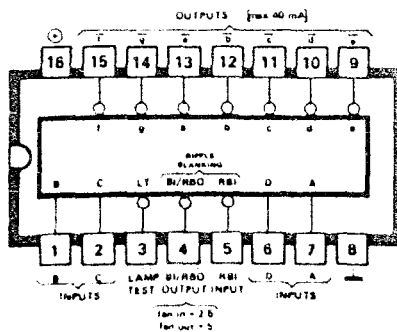

AND GATED J-K POSITIVE EDGE TRIGGERED FLIP-FLOP WITH PRESET AND CLEAR

7470

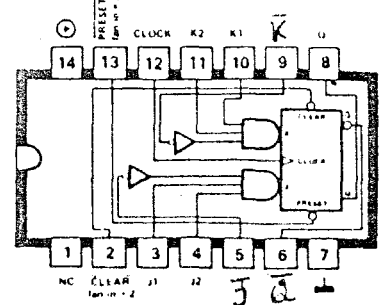

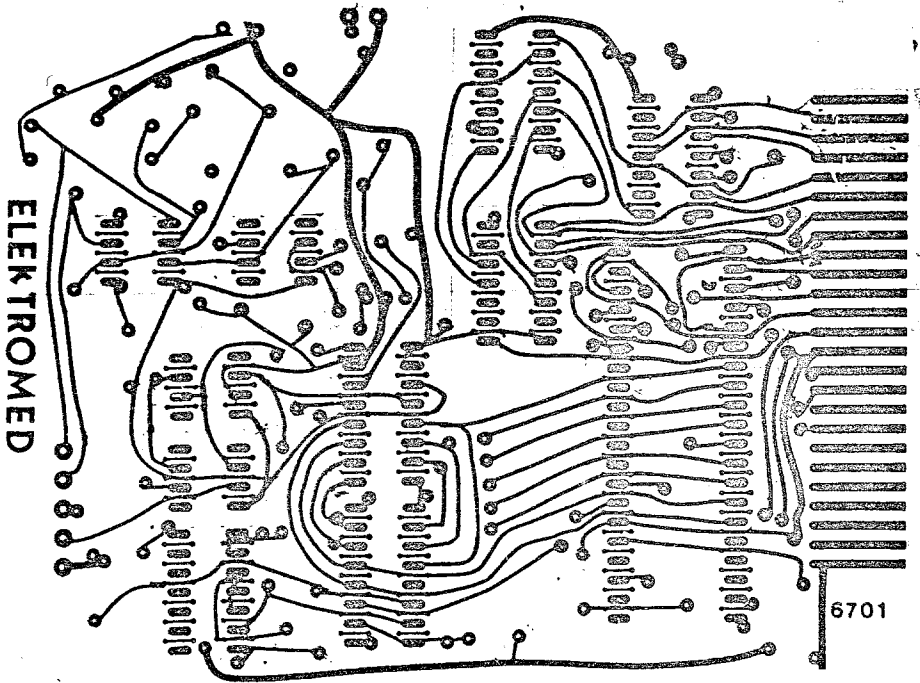
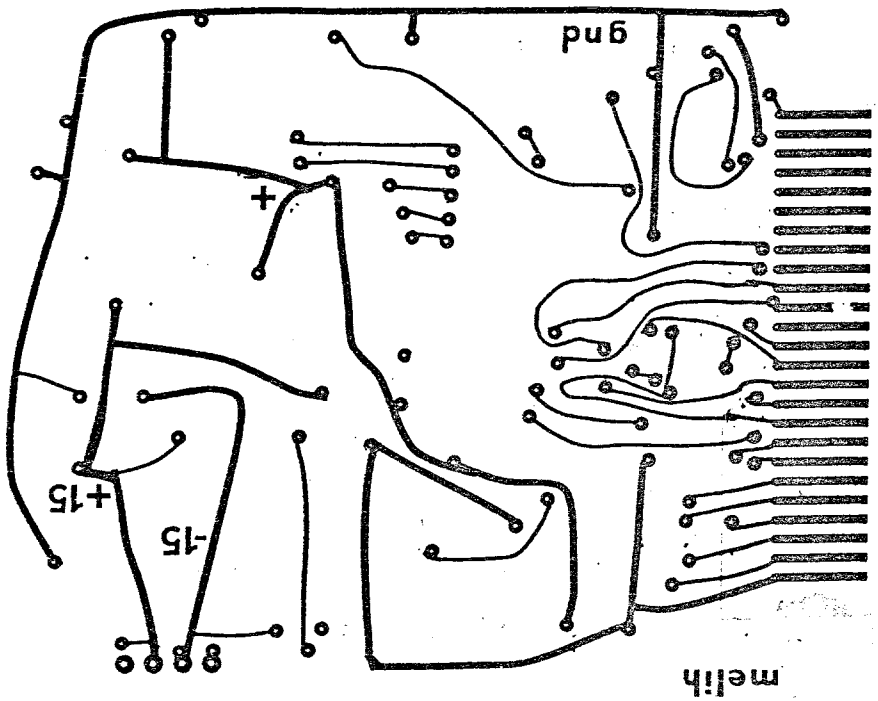

PRINTED CIRCUIT BOARD OF A/D INTERFACE MODULE

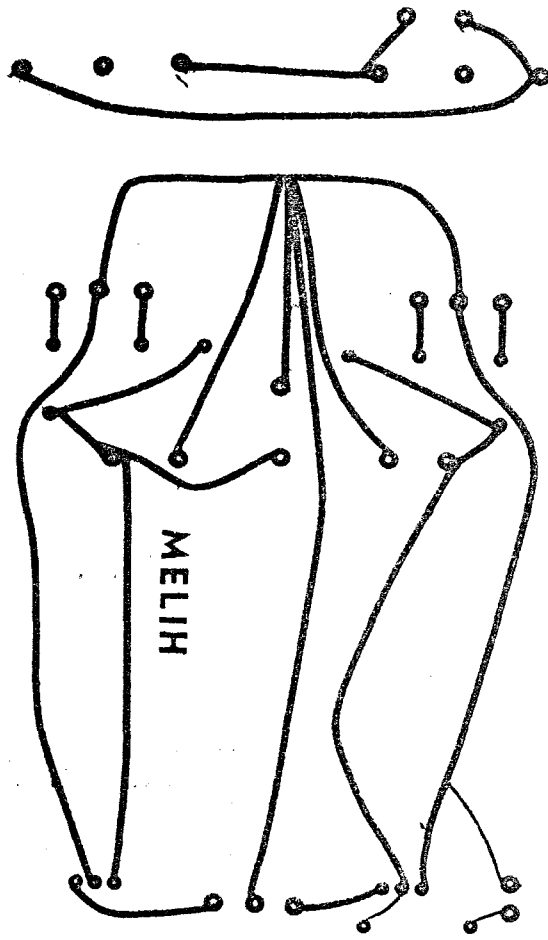

PRINTED CIRCUIT BOARD OF POWER SUPPLY UNIT

### 7.3 A/D CONTROL PROGRAM

This program is for Z80A CPU to control a successive approximation register and get associated data via a PIO, parallel input-output chip.

PIO addresses:

FBF0	PORT A
FBF1	PORT B
FBF2	Control Register of PORT A
FBF3	Control Register of PORT B

PROGRAM:

<u>Address</u>	<u>Code</u>		
PIO INITIALIZATION SUBROUTINE			
6003	21 4E 60	LD HL,#604E	;BEGIN OF THE DATA ADDRESS
6006	3E 00	LD A,0	
6008	77	LD (HL),A	
6009	3E 70	LD A,#70	
600B	23	INC HL	
600C	77	LD (HL),A	
600D	01 F2 FB	LD BC,#FBF2	;CRA
6010	3E 4F	LD A,#4F	;PORT A SET TO BYTE INPUT MODE
6012	ED 79	OUT (C),A	
6014	3E 03	LD A,#03	; INTERRUPT DISABLE WORD
6016	ED 79	OUT (C),A	
6018	01 F3 FB	LD BC,#FBF3	:CRB
601B	3E CF	LD A,#CF	;PORT B SET TO BIT I/O
601D	ED 79	OUT (C),A	
601F	3E FD	LD A,#FD	; I/O REGISTER CONTROL WORD
6021	ED 79	OUT (C),A	
6023	3E 03	LD A,#03	; INTERRUPT DISABLE WORD
6025	ED 79	OUT (C),A	
6025	C9	RET	;END OF PIO INITIALIZATION
A/D SERVICE SUBROUTINE			
6050	3E 02	LD A,#02	
6052	01 F1 FB	LD BC,#FBF1	;PORT B
6055	ED 79	OUT (C),A	;SC PULSE ON
6057	3E 00	LD A,0	
6059	ED 79	OUT (C),A	;SC PULSE OFF
605B	ED 7B	IN A,(C)	
605D	CB 47	BIT 0,A	; ? EOC ON
605F	CA 59 60	JP Z,#6059	; IF NO EOC THEN TEST ONCE MORE
6062	3E 00	LD A,0	
6064	ED 79	OUT (C),A	
6066	2A 4E 60	LD HL,(#604E)	;GET THE ADDRESS OF THE DATA TABLE
6069	23	INC HL	
606A	01 F0 FB	LD BC,#FBF0	;PORT A

```
606D ED 78      IN A,(C)      ;GET A/D DATA
606F 77        LD (HL),A
6070 11 4E 60  LD DE,#604E
6073 7D        LD A,L
6074 12        LD (DE),A
6075 7C        LD A,H
6076 13        INC DE
6077 12        LD (DE),A
6078 C9        RET
```

```

1 ON ERROR GOTO 6000
2 REM          PROGRAM: MONITOR.BAS
3 REM          BIOFEEDBACK MONITOR
4 MODE 2
5 HT$="PRESS ANY KEY TO CONTINUE":MEMORY &5FFF
6 !USER,0:LOAD"sar",&6000
7 CALL &6003
8 DATA 1-SESSION,2-GRAPH,3-SAVING DATA,4-LOADING DATA,5-BF. MONITOR
9 RESTORE 99:MODE 2:PRINT TAB(28);CHR$(24);" BIOFEEDBACK MONITOR ";CHR$(24):FOR I=10 TO 100
10 STEP 2:READ A$:LOCATE 33,I:PRINT A$:
11 NEXT:LOCATE 69,25:PRINT "Melih Aybey";
12 GOSUB 600:ON A GOTO 300,400,450,470,1500
13 GOTO 110
14 REM ***** SESSION *****
15 ADD=&7000:I=0:MI=0:FOR g=&7000 TO &7000+600:POKE g,0:NEXT
16 GOSUB 800
17 EVERY 150,1 GOSUB 900
18 WHILE I<600:WEND
19 PRINT REMAIN (1)
20 GOSUB 650:GOTO 100
21 GOSUB 700:GOTO 350
22 MODE 2:PRINT "PLEASE ENTER PATIENT'S CODE AND SESSION NUMBER CORRECTLY !":GOSUB 650:GOTO 100
23 CLS:GOSUB 500:!USER,1:SAVE FILE$,B,&7000,600:GOTO 100
24 MODE 2:PRINT "FILE DOES NOT EXIST IN THIS DISC.":GOSUB 650:GOTO 470
25 MODE 2:PRINT "PLEASE ENTER PATIENT'S CODE AND SESSION NUMBER CORRECTLY !":GOSUB 650:GOTO 100
26 MODE 2:PRINT TAB(20);" *DATA FILES PRESENT IN THIS DISC*":!USER,1:!DIR:GOSUB 500:LOAD FILE$,&7000:GOTO 400
27 LOCATE 1,18:LINE INPUT "PATIENT'S CODE : ",A$:IF LEN(A$)>8 OR LEN(A$)<1 GOTO 500
28 LOCATE 1,20:LINE INPUT "SESSION NUMBER : ",B$:B=VAL(B$):IF B<1 OR B>999 GOTO 510
29 IF B<10 THEN B$="00"+B$:GOTO 524
30 IF B<100 THEN B$="0"+B$:GOTO 524
31 FILE$=A$+"."+B$:RETURN
32 LOAD FILE$,&6000:GOTO 400
33 A$=INKEY$:IF A$="" GOTO 600 ELSE A=VAL(A$):RETURN
34 T=INT(80-LEN(Y$))/2
35 LOCATE 1,25:PRINT CHR$(24);TAB(T);Y$;TAB(80);SPC(1);CHR$(24);:RETURN
36 PRINT CHR$(24);TAB(W/2);Y$;TAB(79);CHR$(24):RETURN
37 Y$=HT$:GOSUB 610:GOSUB 600:RETURN
38 REM ***** GRAPH *****
39 ADD=&7000:GOSUB 800
40 FOR I=1 TO 600:ADD=ADD+1
41 Y=72+PEEK(ADD):X=24+I:PLOT X,Y
42 NEXT
43 RETURN

```

```

ON ERROR GOTO 6000
REM      PROGRAM: MONITOR.BAS
REM      BIOFEEDBACK MONITOR
MODE 2
HT$="PRESS ANY KEY TO CONTINUE":MEMORY &5FFF
!USER,0:LOAD"sar",&6000
CALL &6003
DATA 1-SESSION,2-GRAPH,3-SAVING DATA,4-LOADING DATA,5-BF. MONITOR
RESTORE 99:MODE 2:PRINT TAB(28);CHR$(24);" BIOFEEDBACK MONITOR ";CHR$(24):FOR I=10 TO 100
STEP 2:READ A$:LOCATE 33,I:PRINT A$:
NEXT I:LOCATE 69,25:PRINT "Melih Aybey";
GOSUB 600:ON A GOTO 300,400,450,470,1500
GOTO 110
REM ***** SESSION *****
ADD=&7000:I=0:MI=0:FOR g=&7000 TO &7000+600:POKE g,0:NEXT g
GOSUB 800
EVERY 150,1 GOSUB 900
WHILE I<600:WEND
PRINT REMAIN (1)
GOSUB 650:GOTO 100
GOSUB 700:GOTO 350
MODE 2:PRINT "PLEASE ENTER PATIENT'S CODE AND SESSION NUMBER CORRECTLY !":GOSUB 650:GOTO 100
CLS:GOSUB 500:!USER,1:SAVE FILE$,B,&7000,600:GOTO 100
MODE 2:PRINT "FILE DOES NOT EXIST IN THIS DISC.":GOSUB 650:GOTO 470
MODE 2:PRINT "PLEASE ENTER PATIENT'S CODE AND SESSION NUMBER CORRECTLY !":GOSUB 650:GOTO 100
MODE 2:PRINT TAB(20);" *DATA FILES PRESENT IN THIS DISC*":!USER,1:!DIR:GOSUB 500:LOCATE 1,18:GOTO 400
LOCATE 1,18:LINE INPUT "PATIENT'S CODE : ",A$:IF LEN(A$)>8 OR LEN(A$)<1 GOTO 500
LOCATE 1,20:LINE INPUT "SESSION NUMBER : ",B$:B=VAL(B$):IF B<1 OR B>999 GOTO 510
IF B<10 THEN B$="00"+B$:GOTO 524
IF B<100 THEN B$="0"+B$:GOTO 524
FILE$=A$+"."+B$:RETURN
LOAD FILE$,&6000:GOTO 400
A$=INKEY$:IF A$="" GOTO 600 ELSE A=VAL(A$):RETURN
T=INT(80-LEN(Y$))/2
LOCATE 1,25:PRINT CHR$(24);TAB(T);Y$;TAB(80);SPC(1);CHR$(24);:RETURN
PRINT CHR$(24);TAB(W/2);Y$;TAB(79);CHR$(24):RETURN
Y$=HT$:GOSUB 610:GOSUB 600:RETURN
REM ***** GRAPH *****
ADD=&7000:GOSUB 800
FOR I=1 TO 600:ADD=ADD+1
Y=72+PEEK(ADD):X=24+I:PLOT X,Y
NEXT I
RETURN

```

```

799 REM ***** SCREEN *****
800 MODE 2:LOCATE 25,2:PRINT "BIOFEEDBACK SESSION MONITOR"
805 LOCATE 3,4:PRINT STRING$(78,CHR$(140)):LOCATE 3,22:PRINT STRING$(78,CHR$(131))
807 FOR J=5 TO 21:LOCATE 3,J:PRINT CHR$(143):LOCATE 80,J:PRINT CHR$(143):NEXT
810 LOCATE 1,5:PRINT "20":LOCATE 1,13:PRINT "10":LOCATE 1,21:PRINT "0"
820 LOCATE 4,23:PRINT "0";TAB(28);"10";TAB(53);"20";TAB(78);"30";:PRINT TAB(71);"TIME [min
822 LOCATE 36,25:PRINT CHR$(24);" E-EXIT ";CHR$(24)
825 CALL &6003
830 RETURN
899 REM ***** SES-A/D *****
900 a$=INKEY$:IF A$="E" OR A$="e" THEN CLS:RUN
905 GOSUB 1000
910 I=I+1:IF I MOD 20=0 THEN MI=MI+1:LOCATE 1,25:PRINT SIL$:LOCATE 1,25:PRINT MI;". MINUTE
920 Y=72+PEEK(ADD)
930 X=24+I
940 PLOT X,Y
950 RETURN
999 REM ***** A/D *****
1000 CALL &6050:ADD=ADD+1:RETURN
1500 ADD=&7000:I=0:MI=0
1510 GOSUB 1800
1520 EVERY 3,1 GOSUB 1900
1530 WHILE I<600:WEND
1540 PRINT REMAIN (1):GOTO 1500
1800 MODE 2
1810 LOCATE 3,4:PRINT STRING$(78,CHR$(140)):LOCATE 3,22:PRINT STRING$(78,CHR$(131))
1820 FOR J=5 TO 21:LOCATE 3,J:PRINT CHR$(143):LOCATE 80,J:PRINT CHR$(143):NEXT
1830 LOCATE 1,5:PRINT "20":LOCATE 1,13:PRINT "10":LOCATE 1,21:PRINT "0"
1835 LOCATE 36,25:PRINT CHR$(24);" E-EXIT ";CHR$(24)
1840 CALL &6003
1850 RETURN
1900 a$=INKEY$:IF A$="E" OR A$="e" THEN CLS:RUN
1910 GOSUB 1000
1920 I=I+1:Y=72+PEEK(ADD):X=24+I
1930 PLOT X,Y
1940 RETURN
6000 IF DERR=146 THEN RESUME 460
6010 IF DERR=144 AND ERL=450 THEN RESUME 440
6020 IF DERR=144 AND ERL=470 THEN RESUME 463
6030 RUN

```

#### 7.4 BIOFEEDBACK MONITOR USER'S MANUAL

To use the system first connect one end of the connection cable to the expansion port of the computer and the other one to the back of the Digital Biofeedback Monitor Interface Unit (DBM I/F-U). Then insert the jack at one end of the connection cable, leading to the dc output of the biofeedback equipment, to the "INPUT" terminal of the interface unit, on the front panel of the box. After that switch on first B/F interface unit and then the computer. The switching sequence must be obeyed as explained above. Next, you must insert program disc into to the disc driver and type: run"monitor" [ENTER]. ([ENTER]=press ENTER key)

After a few seconds a program menu will appear on the screen. It consists of the following sections, each of them being accessible by a keypress of the associated number:

1-SESSION

2-GRAPH

3-SAVING DATA

4-LOADING DATA

5-B/F MONITOR

1-SESSION:

This mode is the session mode, accesible by hitting "1" key in menu. Its use

is to plot the graph of the physiological variable as a function of time during a biofeedback session such that a physician can monitor his patient's state from another room.

First connect the biofeedback equipment to the patient.

When the patient is ready, then press "1"- key to enter this section from menu. At this instant sampling and storage into the memory begins. Now you can observe on the screen the physiological variable being plotted as a function of time and the time elapsed from beginning of the session. At the end of the session, namely at 30. minute, a message line appears at the bottom line, where pressing any key will return you to the menu. If you want to exit before reaching the 30. minute, then press "E"- key, which will make the program to return to the menu.

## 2-GRAPH:

In this section you can observe the graph of the last data, loaded or sampled in a session. Pressing "2"- key in menu is sufficient to enter into this mode. In order to return to the menu press any key when a message line appears at the bottom line at the end of plotting.

## 3-SAVING DATA:

Once you have the data obtained in section 1, in the memory of the computer, you can store it onto a floppy disc for future references. To do this, press

"3"- key in menu, which will take you to a screen, in which patient's code is asked. You can type any alphanumeric characters followed by [ENTER] as a code. This code may be maximum eight characters long and will be used to name the file in which your last data is going to be stored. After that session number is asked. You can enter any number in the range of 1-999 in this stage. This number will appear as the extension of the filename. For example, if the patient's code is JACK and his session number is 4, then associated filename is constructed as "JACK .004". The program returns to menu if the given names are legal, otherwise these are asked again.

#### 4-LOADING DATA:

In order to analyse any old data, first you have to load the associated data file into the memory of the computer by using this section. When you press "4"- key in menu, then you are faced with a screen consisting of the list of the data files present in your disc. Each filename has two parts separated by a dot. The part before the dot is the patient's code and the other one after it shows the session number. To load any data type in patient's code followed by [ENTER] and after that session number followed by [ENTER]. In case of any error you are asked to do all once again, otherwise the loaded data is plotted just after loading, exactly in the same manner like in part 2.

#### 5-B/F MONITOR:

The system can be used also as a biofeedback monitor by the patient. The state

of the physiological variable under training can be followed on the screen instead of any analog or digital meter. In this case the level of the physiological variable is plotted on the screen as a function of time. The only difference from session-part is the speed of the sampling. In session mode a data for the whole session is collected for 30 minutes as a result sampling rate equals to one sample in every 3 seconds. In B/F monitor mode sampling rate increases to 50/3 samples/sec and is more convenient for the patient to use than the therapist where session mode is more appropriate for the therapist.

This section is designed for continuous monitoring. In case you want to leave it press E-key.

Digital Biofeedback Monitor

## VIII. DISCUSSION AND CONCLUSION

Homeostatic adaptive control systems are responsible for the survival of the organism. These systems use various types of closed loop control mechanisms, namely feedback, and keep essential physiological variables within critical limits. The state of these internal physiological variables are normally monitored only by Homeostatic Adaptive Control Systems, which are able to control them. Our natural monitoring devices are our senses which are only sensible to outside world. In case of the necessity to measure any physiological parameter special biomedical devices, which are designed for this purpose, are used. Our senses are not able to monitor any internal physiological parameter.

In order to control any variable its state must be known by the controller. We can not control any internal parameter since there is no information about them. Supplying such information will build a new, artificial feedback path from internal physiological parameters to our senses, closing the control loop and placing our mind as the controller of this closed loop control system. Only after that we have a chance to control associated internal parameter. This new, artificial closed loop control system is built up by biofeedback.

Biofeedback therapy differs from classical methods. A biofeedback device, which supplies information from internal physiological variables to the human's senses, together with the sensory organs comprises the feedback path

Discussion and Conclusion

of the system. This feedback path conveys information to the controller, namely to the brain of the patient. After this point on, all of the work is done by the mind-brain of the patient and the physician plays the role of an instructor.

A conventional biofeedback equipment is usually designed as to be a monitor for the patient. The physician can not follow his patient's session closely since he may disturb the patient, and the data about the physiological variable is lost just after the instant it is monitored. The Digital Biofeedback Monitor is designed to omit these shortcomings. Using it a physician can monitor his patient during a session in a distant place without disturbing him. After the end of the session the data related to the physiological variable can be stored on a floppy disc and can be used in comparing the data obtained in previous sections, which gives an idea about the patient's learning performance. Another application could involve the use of the DBM as a means of supplying useful feedback information (EMG, Pulse or other) to the patient. The DBM can prove to be more efficient than the sound or instantaneous visual methods. Future work should involve the assessment of the clinical usefulness of such a procedure.

#### Discussion and Conclusion

## APPENDIX A - ABBREVIATIONS

DBM	Digital Biofeedback Monitor
HACS	Homeostatic Adaptive Control Systems
CNS	Central Nervous System
EMG	Electromyogram
EEG	Electroencephalogram
GSR	Galvanic Skin Response
ECG	Electrocardiogram
CMMR	Common Mode Rejection Ratio
A/D	Analog to Digital converter
D/A	Digital to Analog converter
CRT	Cathode Ray Tube
CPU	Central Processor Unit
RAM	Random Access Memory
PIO	Parallel Input-Output
OP-AMP	Operational Amplifier
SAR	Successive Approximation Register
CRA	Control Register of PORT A
CRB	Control Register of PORT B
I/O	Input-Output
SC	Start Conversion
EOC	End Of Conversion

# COMPONENTS OF A BIOFEEDBACK SYSTEM

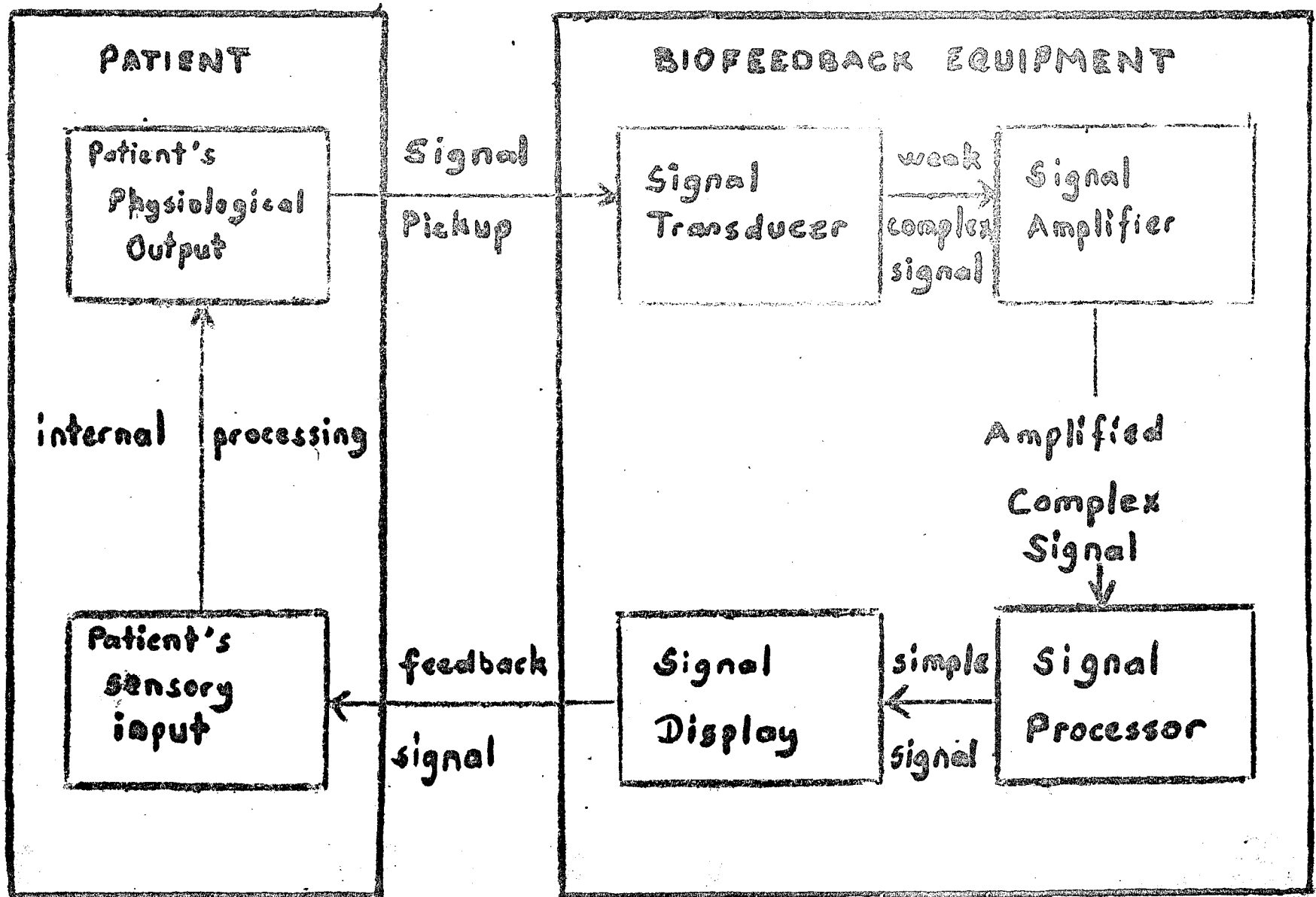

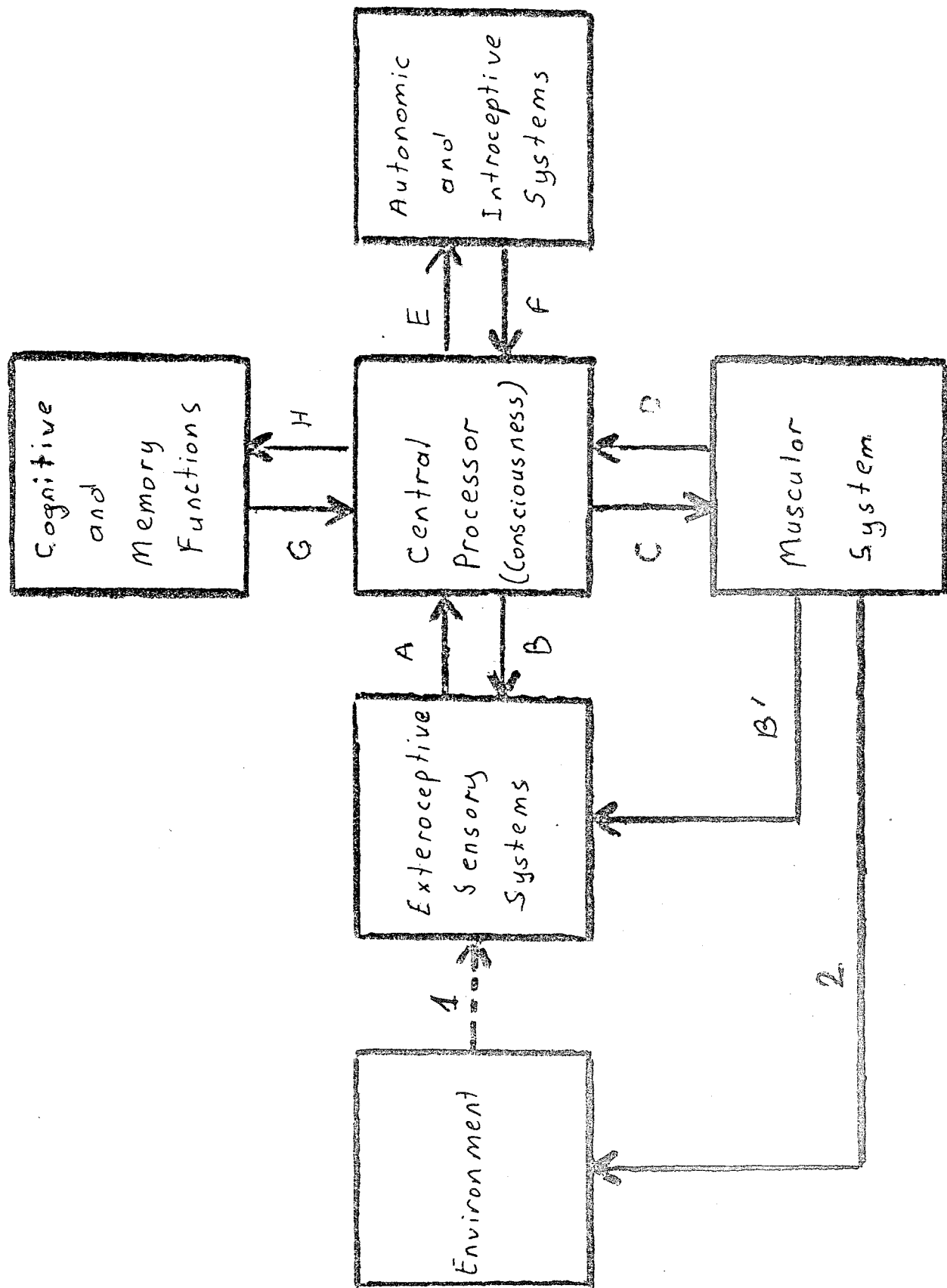
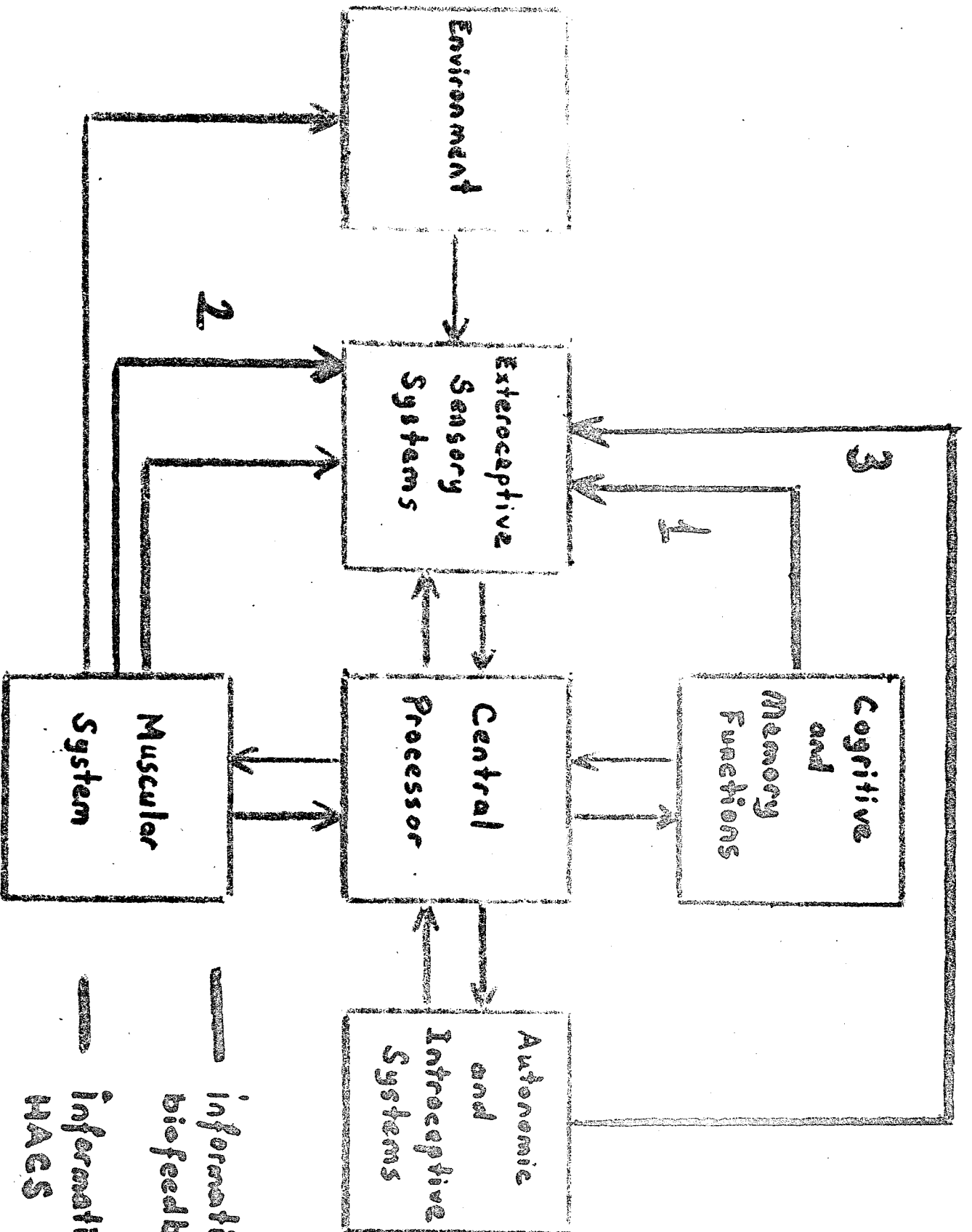

FIGURE T-1

# Biofeedback



2

1

3

- information channels due to biofeedback
- information channels due to MAES

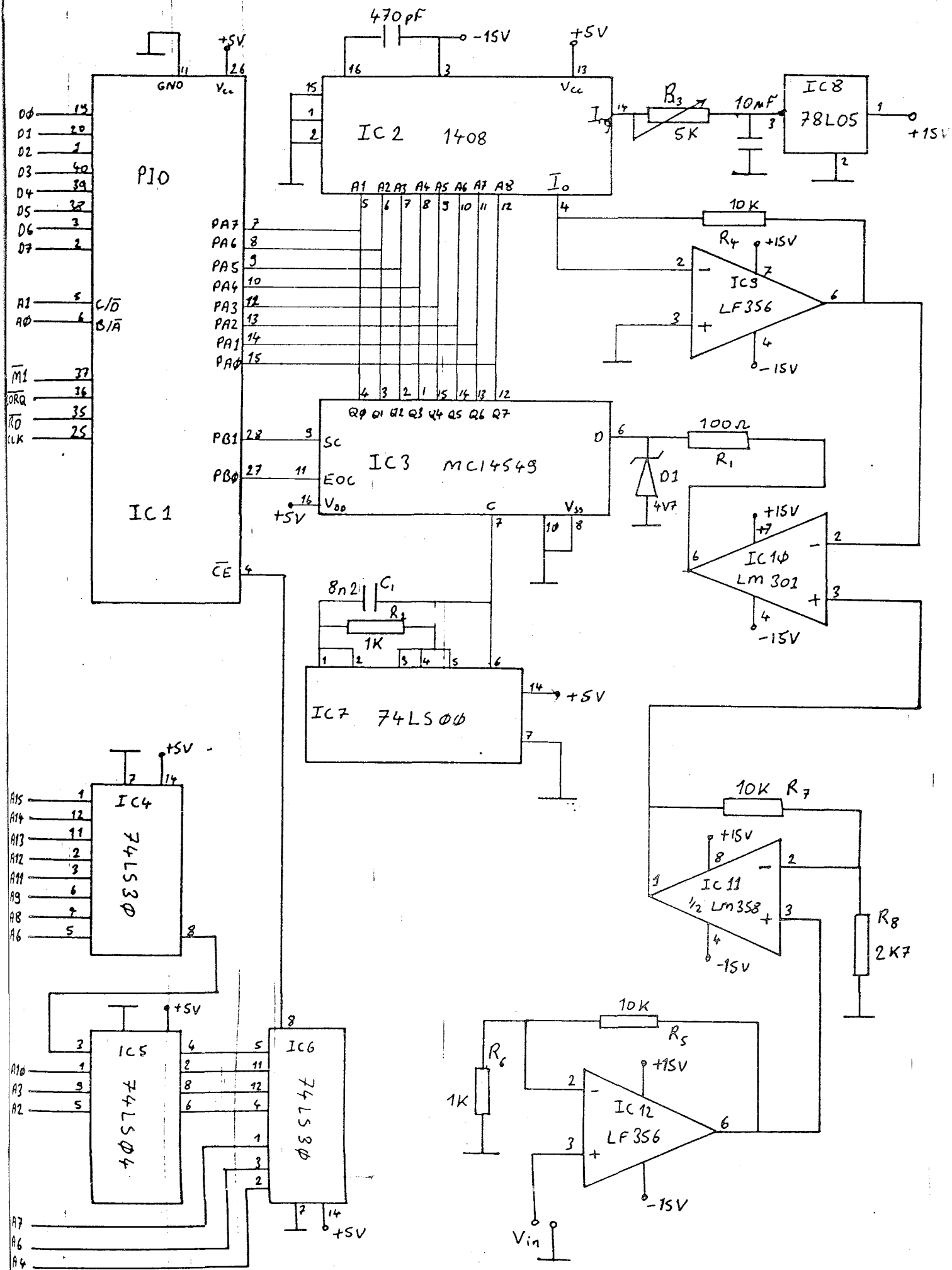

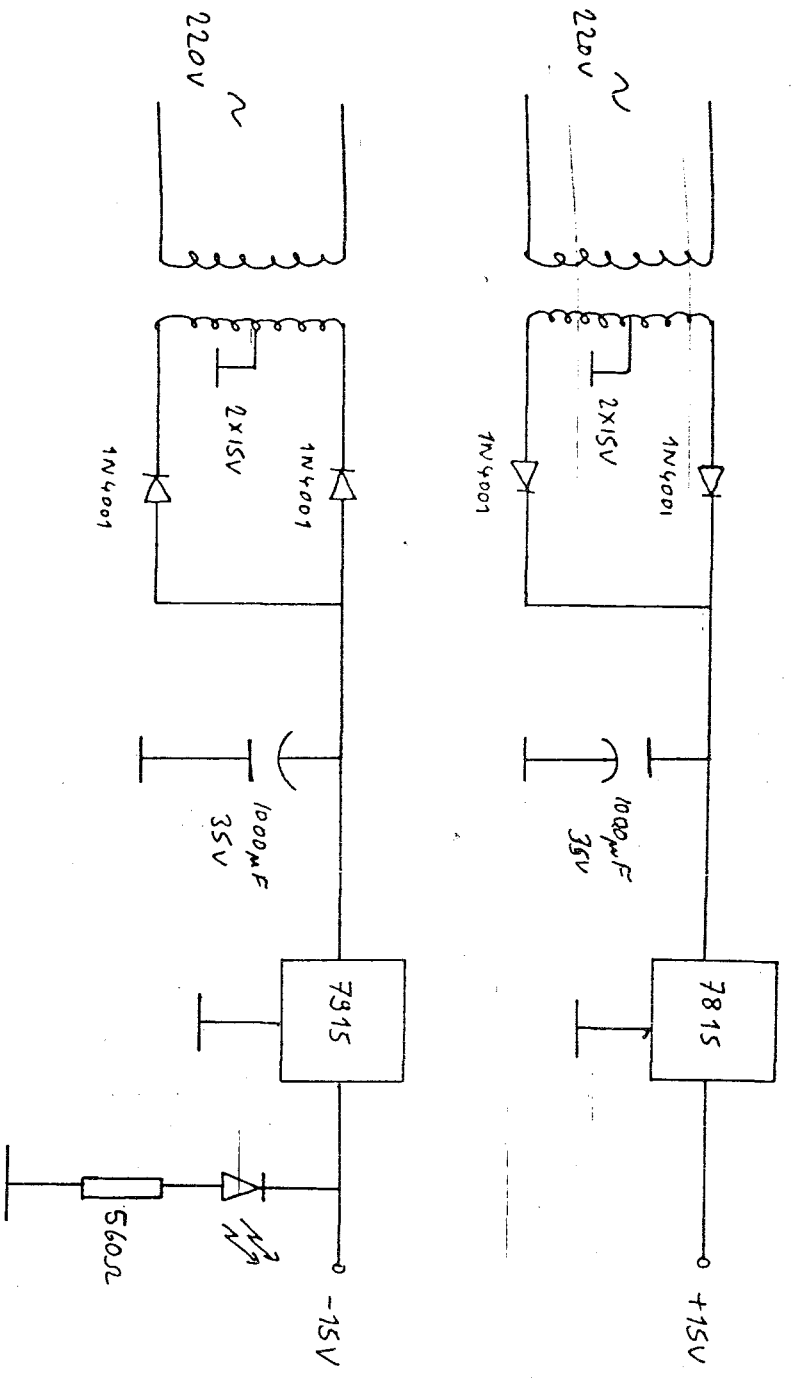

POWER SUPPLY UNIT

HT-1

# AUTOGEN<sup>®</sup>

**THE INSTRUMENT** The HT-1 EMG is an easy to use portable trainer with specifications which substantially exceed those of competing home training units (see reverse side).

Electromyographic feedback requires extensive filtering of non-EMG signals; the HT-1 provides a cleaner feedback signal than any competitive portable device. The instrument is housed in a tough outer shell which enhances durability and stability of the instrument over extended usage.

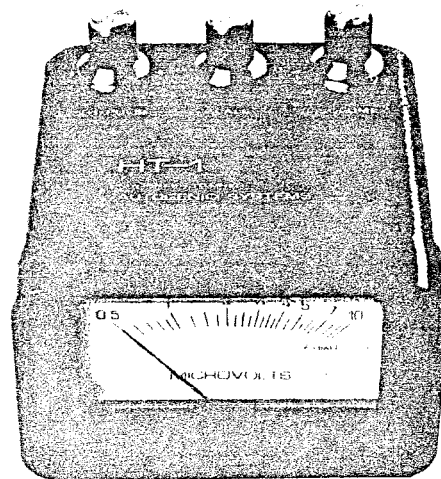

*electromyograph*

For Home and Clinical Training

## FEATURES

- COMPATIBLE WITH ALL AUTOGENICS<sup>®</sup> INSTRUMENTS
  - HIGH SENSITIVITY (0.4 MICROVOLTS RMS)
    - LARGE, EASY TO READ METER
    - FIVE SELECTABLE METER SENSITIVITY SCALES
  - TWO AUDIO FEEDBACK MODES
    - BUILT-IN SPEAKER
    - VOLUME CONTROL
  - INSTRUMENTATION OUTPUT FOR DATA ACQUISITION
    - ATTACHES TO HEADPHONES OR EXTERNAL SPEAKERS
    - BATTERY TEST FUNCTION

For Home and Clinical Training

## FEATURES

- COMPATIBLE WITH ALL AUTOGENICS<sup>®</sup> INSTRUMENTS
  - HIGH RESOLUTION
    - LARGE, EASY TO READ METER
    - FIVE SELECTABLE METER SENSITIVITY SCALES
  - TWO AUDIO FEEDBACK MODES
    - BUILT-IN SPEAKER
    - VOLUME CONTROL
  - INSTRUMENTATION OUTPUT FOR DATA ACQUISITION
    - ATTACHES TO HEADPHONES OR EXTERNAL SPEAKERS
    - BATTERY TEST FUNCTION

HT-2

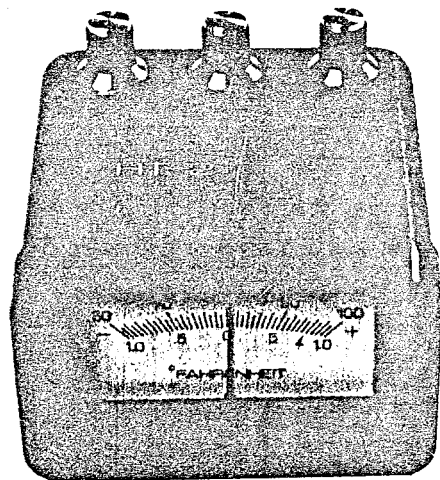

*temperature feedback monitor*

**THE INSTRUMENT** The HT-2 skin temperature trainer is an easy to use portable trainer which provides a unique array of features for home and office training applications. For optimum visual readout, the unit incorporates a zero-center meter selector with five selectable positive and negative deflection ranges and a resolution of up to .025 degrees Fahrenheit. The unit is compact without sacrificing meter readability which is a problem with many competitive portable instruments. The unit is housed in a tough outer shell which enhances durability and stability of the instrument over extended usage.

# AUTOGEN

**THE INSTRUMENT** The HT-3 Dermograph Trainer is an easy to use portable trainer which provides feedback of both skin conductance level and skin conductance response. Visual feedback is provided by a meter which incorporates six selectable sensitivity scales and provides substantially higher resolution and stability than competitive skin conductance trainers. The unit is compact without sacrificing meter readability which is a problem with many portable training units.

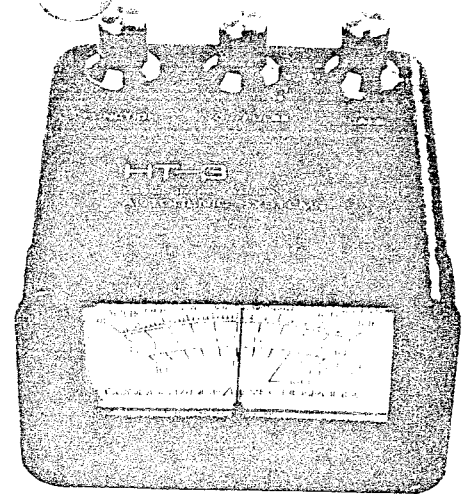

*feedback dermograph*

For Home and Clinical Training

## FEATURES

- COMPATIBLE WITH ALL AUTOGENICS\* INSTRUMENTS
  - HIGH SENSITIVITY
  - LARGE, EASY TO READ METER
  - SIX SELECTABLE METER SENSITIVITY SCALES
- TWO AUDIO FEEDBACK MODES
  - BUILT-IN SPEAKER
  - VOLUME CONTROL
  - INSTRUMENTATION OUTPUT FOR DATA ACQUISITION
- ATTACHES TO HEADPHONES OR EXTERNAL SPEAKERS
- BATTERY TEST FUNCTION

For Home and Clinical Training

## FEATURES

- COMPATIBLE WITH ALL AUTOGENICS\* INSTRUMENTS
  - COMPUTE-TIME INTERVAL SELECTOR
  - AUTOMATIC START/RESET CYCLE
  - LARGE, EASY TO READ DIGITAL DISPLAY
  - SMALL, LIGHTWEIGHT
  - HIGHLY ACCURATE
  - RECHARGEABLE BATTERIES

# HT-10

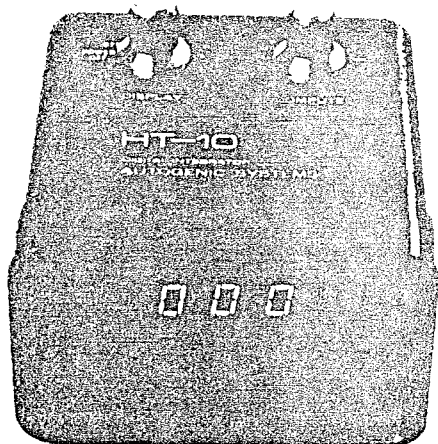

*digital integrator*

**THE INSTRUMENT** The HT-10 Digital Integrator is the smallest and most portable digital data acquisition instrument available for biofeedback applications. Despite its diminutive size, the HT-10 is capable of displaying and time-averaging physiological activity with an absolute accuracy of better than plus or minus 1 percent over a variety of selectable time intervals ranging from 1 second to 20 minutes. Time-averaged data is presented on the highly readable digital display over intervals of 10 seconds, 2.5 minutes, or over a time interval equivalent to that used for data recording.

## INDIVIDUAL INSTRUMENTS

## INTEGRATED SYSTEMS

MODEL	DESCRIPTION
<b>EMG</b>	
J33	Portable, single channel, audio and visual
J53	Portable, dual channel, ratio and Lite Bar™
P303	Clinical trainer, 4 audio modes and Lite Bar™
<b>CARDIO-VASCULAR</b>	
J42	Portable thermometer, digital display and Lite Bar™
P642	Clinical thermometer, 3 audio modes, digital display and Lite Bar™
BL907	Measures heart rate and changes in blood pressure (via pulse wave velocity)
<b>SKIN POTENTIAL RESPONSE</b>	
BL505	Clinical unit, measures changes in sympathetic activity
<b>DATA ACCUMULATORS AND RECORDERS</b>	
Q700	Data Accumulator for a percent time & time period integration scoring
Q740	Automatic digital printer
O910	Single channel strip chart recorder
Q920	Dual channel strip chart recorder
1.	<b>PORTABLE SYSTEM: J33 and J42</b> The two most widely used modes (EMG and thermal) in lightweight units with durable carrying case. A logical system for start-up. Battery powered.
2.	<b>REHABILITATION SYSTEM: J53, Q700, Q740</b> A basic physical/occupational therapy system. Includes a two channel portable EMG with ratio capability, quantification via digital display, print-out of integrated or percent time scores.
3.	<b>RELAXATION TRAINING: P303, P642, BL907, Q700</b> Measures complete physiological profile (EMG, Thermal, Blood Pressure, Heart Rate). Determines mode most responsive to stress/relaxation, and trains in any mode. System elements can be used singly or together.
4.	<b>PSYCHOTHERAPY SYSTEM: P303, Q700, BL505</b> Designed for use with verbal psychotherapy, desensitization and relaxation training, as well as teaching other self control abilities. Measures EMG and SPR (dermal response).
5.	<b>CARDIO-VASCULAR SYSTEM: J42, BL907</b> Continuous measurement of three cardiovascular variables — temperature, heart rate and changes in blood pressure (via pulse wave velocity). The ideal flexible system for treating cardiovascular problems.
6.	<b>CLINICAL BIOFEEDBACK SYSTEM: P303, Q700, P642, Q740</b> Clinic system with EMG/thermal modes, accumulator, percent time/time period integration and automatic digital printer. This is Cyborg's most popular clinical system. It is easy to use and the units can be used separately or together.
7.	<b>COMPREHENSIVE SYSTEM: P303, P642, Q700, BL907, BL505, Q910</b> All modalities with complete monitoring, training, data accumulation and recording capability. Excellent for education and research as well as sophisticated clinical practices

activity and translates them into an audible tone or visual readout.

**EMG 100T** monitors muscle tension in various muscle areas (forehead, jaw, etc.) to assist in relaxation training and muscle rehabilitation. It detects signals of less than .3 uV RMS and provides 1% accurate Raw and True d.c. RMS EMG outputs for research and data acquisition.

**HR/BVP 100T** is a dual function instrument that provides absolute heart rate and relative blood volume pulse amplitude feedback. The latter is an

extremely responsive measure, registering beat-to-beat changes in sympathetic arousal much more rapidly than temperature.

**BIOFEEDBACK 5** comes in a rugged carrying case with all accessories for each system, including interconnection and data acquisition cables, dual sensitivity meter, reverse temperature probe, headband with electrodes, 3 stainless steel electrodes, electrode gel, manuals and all batteries. #T2750 \$499.00 (9.95)

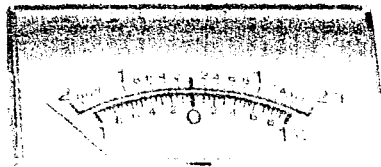
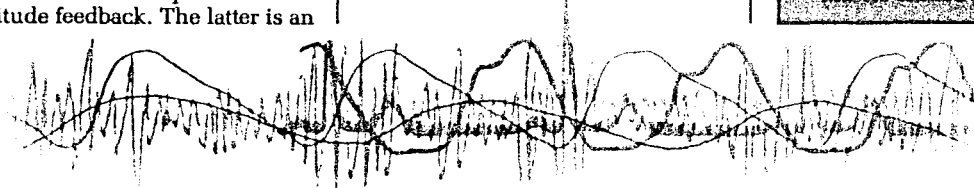
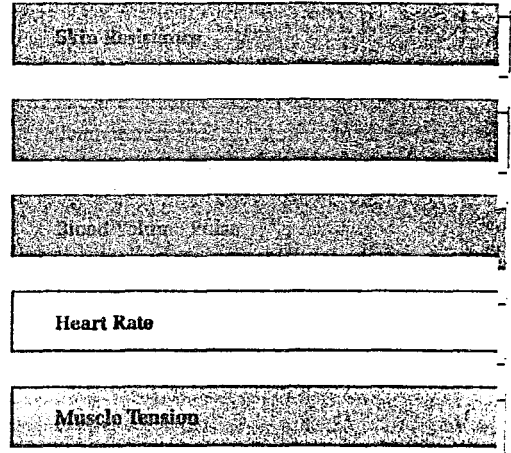

## BIOFEEDBACK 5 DIGITAL™

Includes the complete BIOFEEDBACK 5 system plus the TEMP/SC 200T, for absolute digital readout of all monitors in the set. TEMP/SC 200T also provides rapid absolute readout of temperature and skin conductance with enhanced tone feedback. (for fuller description see TEMP/SC 200T section). #T2751 \$699.00 (10.95)

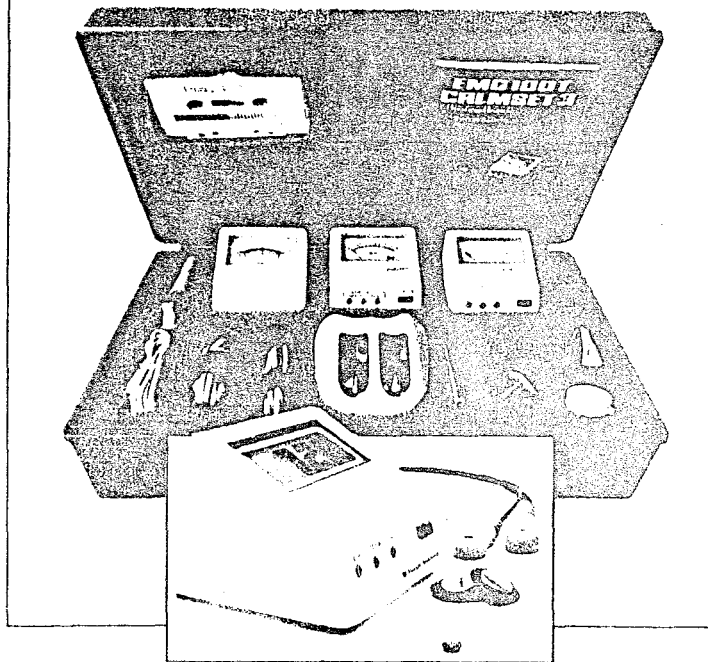

# GSR 2 GSR/TEMP 2™

Blood Volume Pulse

Heart Rate

Muscle Tension

■ GSR 2 uses biofeedback to help control tension by monitoring minute changes in galvanic skin resistance or skin pore size in response to stress. The unit turns itself on automatically at the touch of one's fingers. One can, through simple relaxation exercises, learn to lower the tone and thus lower his or her tension level. Instant feedback expedites this learning process by signalling the success of efforts that contribute to relaxation. Includes monitor, instructions, tape. #T2001 \$49.95 (3.95)

Deluxe GSR 1 handcrafted in solid walnut with gold-plated sensors. #T1915 \$79.95 (3.95)

■ Alternately, an increasing stress level causes peripheral vasculature to constrict, lessening blood flow to hands and feet and lowering extremity temperatures. GSR/TEMP 2, as well as providing an added visual readout of GSR, also monitors changes in extremity temperatures to help the user control tension. Increases in temperature (increased relaxation) produce an increase in meter reading or pitch; an optional probe reverses this relationship. Changes of less than .1°F (.05°C) can be monitored. Also included; a standard meter for GSR or temperature feedback, remote GSR sensors thermometer, tape, and carrying case. #T2100 \$99.95 (5.95)

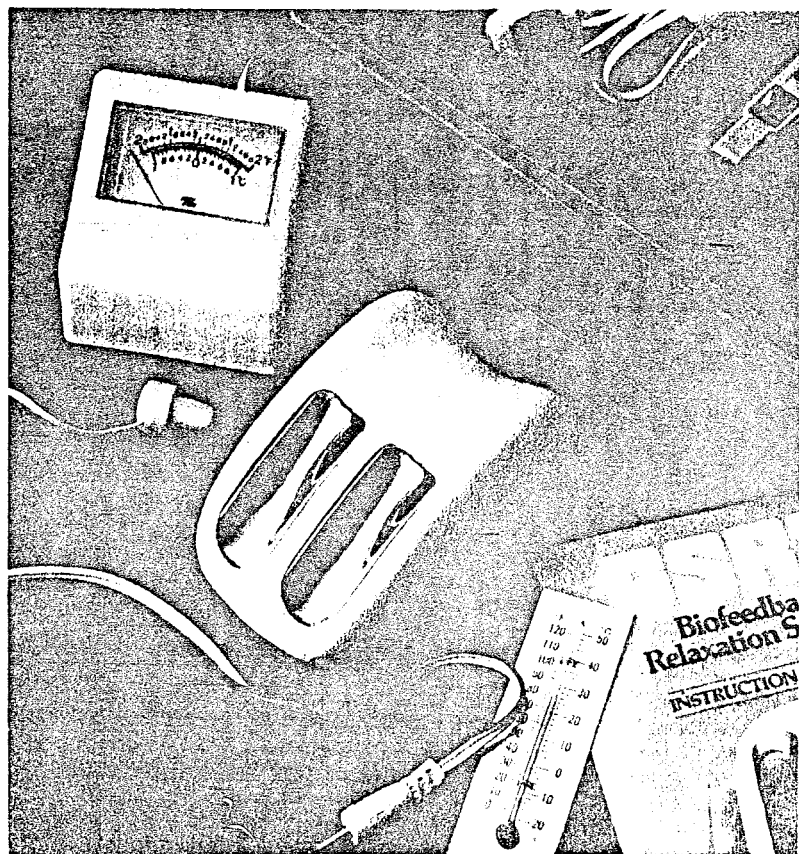

**GSR**  
 Skin Resistance range: 1,000 ohms to 3,000,000 ohms.  
 Resolution: < .5% of base resistance  
 Electrode current: < 45 microamps.  
**TEMP**  
 Temperature Range: 50°F (10°C) to 110°F (43°C)  
 Resolution: .1°F (.05°C)  
**GENERAL**  
 Variable Frequency Range: 50 to 20,000 Hz  
 2.5 mm output jack for 8 ohm earphone and meter.  
 3.5 mm input jack for temperature respiration, heart rate, BVP, EMG and remote sensors  
 Battery: 9V (included)

# HR/BVP 100T™

Heart rate monitors have long played a role in detecting cardiovascular problems and in the detection of anxiety. Now, Thought Technology combines a compact, highly accurate heart rate monitor with a blood volume pulse measurement in a single instrument to provide valuable relative and absolute feedback.

The HR/BVP 100T works independently or in combination with the GSR/TEMP 2 or TEMP/SC 200T systems. It can detect changes as small as a 1/2 beat per minute and blood volume pulse changes of 1% in both audio and visual modes. Thresholds can be set to facilitate

desensitization of phobias and anxiety or to minimize cardiac risk during home exercise or aerobic training by signalling excessive heart rate.

Blood volume pulse is a measurement of pulse amplitude at the fingertips caused by changes in the sympathetic nervous system. This provides extremely quick feedback of beat-to-beat changes in tension levels yielding results more rapidly than temperature monitoring.

System includes monitor with photoplethysmograph finger pickup, GSR output cable, instructions, tape, and carrying case.  
#T2400 \$199.95 (5.95)

Skin Resistance
Temperature
Heart Rate
Muscle Tension

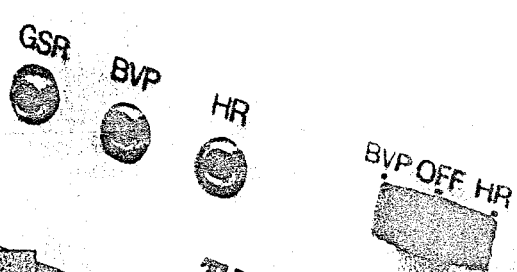
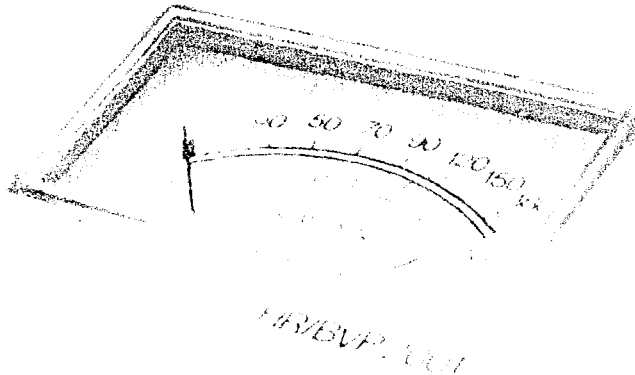
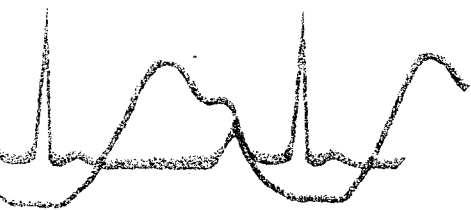

Specifications:	
Measurement range:	30-200 Beats/Min.
Input:	Finger Plethysmograph
Outputs:	HR: 100 mVdc
	BVP: 100 Beats/Min.
	BVP (raw): 200 mV Full Scale
GSR:	(connects to GSR 2 for audio feedback and to control other accessories connected to GSR 2 including Meter, Colmatone.)
Meter Functions:	Semi-Linear scale 30-200 Beats/Min. 0-100 for enhanced reading

*Handwritten notes:*  
5/11  
6/11  
7/11  
65  
63  
62

Thought Technology Ltd. In U.S.A. call toll free: 1-800-361-3651

# TEMP/SC 200T™

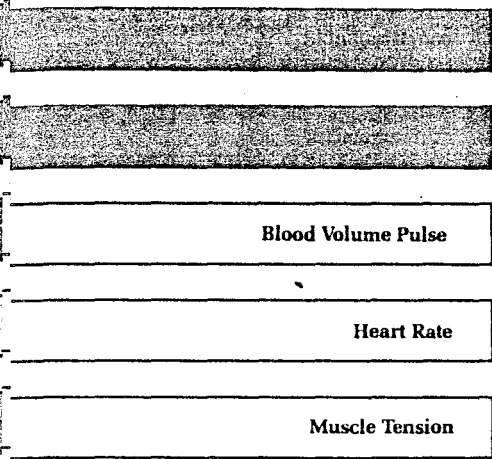

With TEMP/SC 200T, Thought Technology uses digital instrumentation to achieve a significant new level of accuracy without sacrificing the compactness and portability needed in the doctor's office, the clinic and at home. The digital readout and built-in speaker ensure superior accuracy and quality of visual and adjustable tonal feedback. Response in the temperature mode is rapid and offers .1°F visual, and less than .05°F audible resolution. Skin conductance as a mode of measurement is more accurate and responsive than GSR: ideally suited for both clinical and home training en-

vironments. TEMP/SC 200T provides two channel monitoring for data acquisition of SC and temperature as well as providing digital readout and tonal feedback for the EMG 100T and HR/BVP 100T for monitoring muscular activity, heart rate and blood volume amplitude.

System includes meter, temperature probe, stainless steel electrodes, SC cable with snap-on connectors, gel, carrying case, instruction manual, tape.

#T2650 \$199.95 (5.95)

Temperature only

#T2651 \$174.95 (5.95)

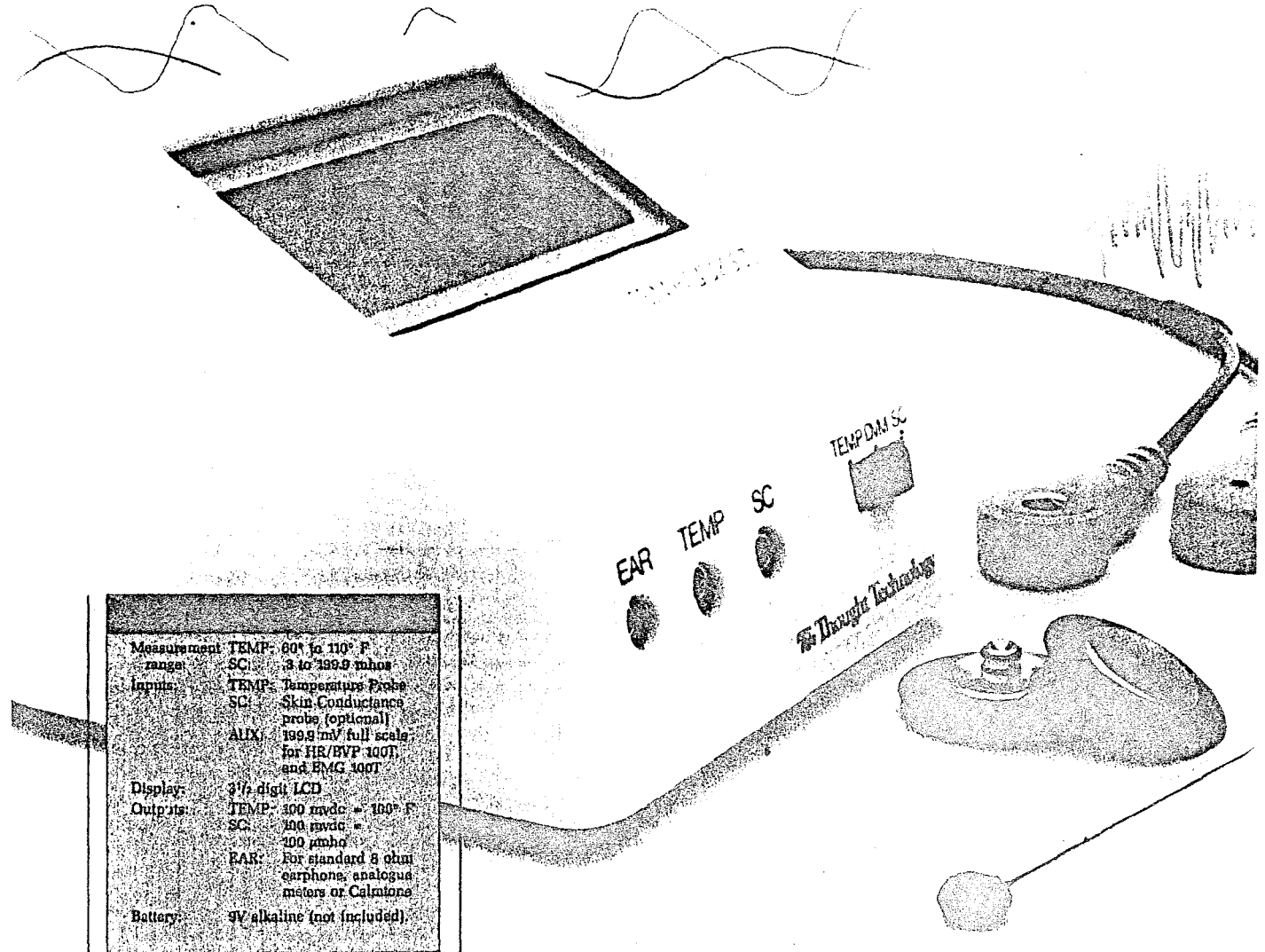

Measurement range:	TEMP: 60° to 110° F
	SC: 3 to 199.9 mhos
Inputs:	TEMP: Temperature Probe
	SC: Skin Conductance probe (optional)
	AUX: 199.9 mV full scale for HR/BVP 100T and EMG 100T
Display:	3 1/2 digit LCD
Outputs:	TEMP: 100 mVdc to 100° F
	SC: 100 mVdc
	100 $\mu$ hos
	EAR: For standard 8 ohm earphone, analogue meters or Caltronic
Battery:	3V alkaline (not included)

# EMG 100T™

# CALMSET 3™

Electromyography (EMG), measurement of muscle activity, is the mode of feedback most extensively used in both clinics and research for chronic pain, muscular disorder and relaxation training. It has also proved successful in muscle rehabilitation since it can often detect residual muscular activity.

EMG 100T represents a giant step forward in both performance and price for EMG monitors. With the accuracy required for research and data acquisition, it is also affordable enough to fit into any stress management package.

Athletes use EMG 100T to achieve superior performance through increased concentration and optimum use of energy.

EMG 100T is a two range monitor providing absolute EMG and when connected to the GSR yields relative and threshold information feedback through a variable tone.

System includes meter with 2 EMG ranges, stainless steel electrodes, cable with 3 snap connectors, electrode gel, GSR interconnect cable, belt loop attachment, cassette tape, instruction manual and carrying case. #T2320 \$199.95 (5.95)

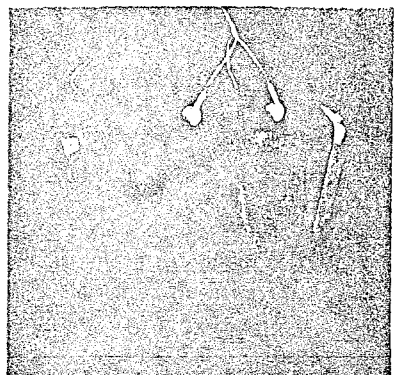
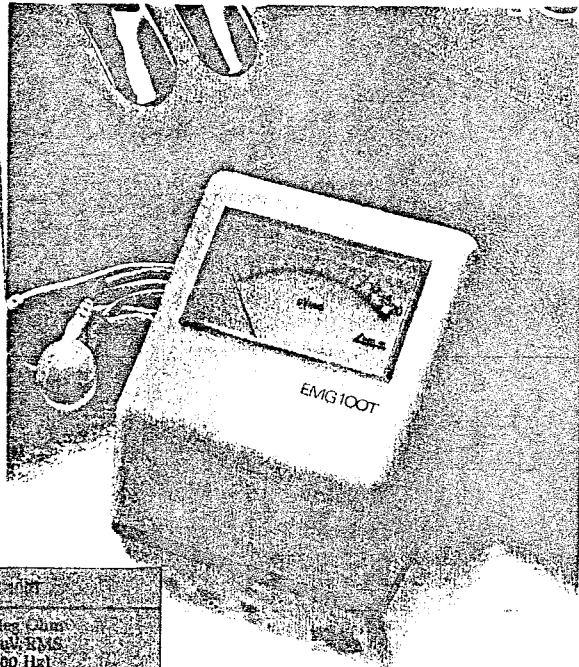
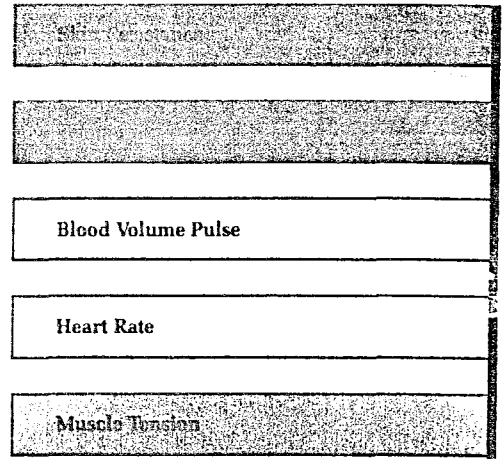

This lightweight headset meets clinical standards in monitoring EMG, GSR and Temperature. Yet it has been designed for home use, providing the simplicity of operation, convenience and privacy that makes relaxation training and muscle rehabilitation, without supervision, enjoyable and effective.

CALMSET 3 features sensitivity, pitch and volume controls for GSR, EMG and Temperature; headband with stainless steel electrodes extendible for use on other body areas; electrode gel, GSR finger electrodes, reverse temperature probe, carrying case. #T2510 \$199.95 (5.95)  
EMG Version only #T2521 \$169.95 (5.95)

Specifications:	EMG 100T
Input impedance:	100 Meg Ohms
Sensitivity:	> 0.2 uV RMS (100-200 Hz)
CMRR:	100 dB
Filters:	60 Hz powerline rejection: 80 dB
Band pass:	100-200 Hz
High pass:	40 dB/oct
Low pass:	20 dB/oct
Range:	2-400 uV RMS
Outputs:	
Raw (100-200 Hz):	100 mV - 100 uV
DC:	100 mVDC
	= 100 uV RMS
GSR:	connects to GSR 2 for data acquisition or TEMP/SG 200T for audio feedback or to control CALMTONE stereo controller.
Battery:	9V Alkaline (not included)

Specifications:	CALMSET 3
EMG:	as for EMG 100 T
GSR:	as for GSR 2
TEMP:	as for GSR/TEMP 2
Inputs:	
	3.5 mm jack for external electrodes, GSR electrodes, temperature probes, respiration sensor and HR/BVP 200T
	3.5 mm stereo jack for external audio signal.
Outputs:	
	3.5 mm jack for meter and CALMTONE Stereo Controller.

## REFERENCES

- 1) BIOFEEDBACK CLINICAL APPLICATIONS IN BEHAVIORAL MEDICINE  
by David S. Olton and Aaron R. Noonberg
- 2) STRESS AND THE ART OF BIOFEEDBACK  
by Barbara Brown
- 3) CLINICAL BIOFEEDBACK  
by Kenneth R. Gaarder
- 4) BIOMEDICAL INSTRUMENTATION AND MEASUREMENTS  
by L. Cromwell, F. J. Weibell, E. A. Pfeifer
- 5) A/D - D/A APPLICATION MANUAL  
by Motorola Semiconductors
- 6) LINEAR DATABOOK  
by National Semiconductors
- 7) Z80 CENTRAL PROCESSING UNIT PRODUCT SPECIFICATION  
by Zilog Inc.
- 8) Z80 PIO PARALLEL INPUT/OUTPUT CONTROLLER  
by Zilog Inc.
- 9) HUMAN PHYSIOLOGY  
by Vander, Sherman, Luciano