

SEISMIC STRENGTHENING OF EXISTING RC FRAME BUILDINGS  
BY STEEL PANELS

by

Başak SEZER

B.S., Civil Engineering, Yıldız Technical University, 2004

Submitted to the Kandilli Observatory and Earthquake Research Institute  
for Graduate Studies in Earthquake Engineering in partial fulfillment of  
the requirements for degree of  
Master of Science

Graduate Program in Earthquake Engineering

Boğaziçi University

2008

To my husband;

## ACKNOWLEDGEMENTS

I want to express my deepest gratitude to Dr. Waiel Mowrtage for his guidance, advice, motivation, criticism, encouragements in the scope of this research. I would never able to finish this thesis without his valuable suggestions.

I want to express special thanks to my husband Hakan Sezer for his help and invaluable support when I come across any kind of difficulties during my thesis study. I can never finish this without his support.

I want to thank to Gnkut Barka for his courage and patience during my graduate period and sharing his invaluable experience in civil engineering.

My parents Jale Kızıltan, Engin Kızıltan are always supported me and never left me alone in my life.

Finally, I am grateful to all instructors and assistants of Boğaziçi University, Kandilli Observatory and Earthquake Research Institute, Department of Earthquake Engineering for their valuable contributions to my academic knowledge.

## **ABSTRACT**

### **SEISMIC STRENGTHENING OF RC FRAME BUILDINGS BY STEEL PANELS**

Every major earthquake in Turkey causes a large number of buildings to suffer moderate damage due to poor construction. If a proper and fast retrofit is not applied, the aftershocks, which may sometimes come days or weeks after the main shock, can push a moderately damaged building into a major damage or even total collapse. Retrofitting these poorly constructed buildings using traditional methods may cost a lot of money, labor and time which make the choice of reconstruction better than retrofitting. This research presents a practical retrofit method for moderately damaged buildings, which increases the seismic performance of the structural system by reducing the displacement demand. Fabricated steel panels are used for the retrofit. They are light-weight, easy to handle, and can be constructed very quickly. Moreover, they are cheap, and do not need formwork or skilled workers. They can be designed to compensate for the stiffness and strength degradation, and to fit easily inside a moderately damaged reinforced concrete frame. To test the concept, a half-scale, single-story 3D reinforced concrete frame specimen was constructed at the shake-table laboratories of the Kandilli Observatory and Earthquake Research Institute of Bogazici University, and subjected to recorded real earthquake base accelerations. The amplitudes of base accelerations were increased until a moderate damage level is reached. Then, the damaged RC frames were retrofitted by means of steel panels and tested under the same earthquake. The seismic performance of the specimen before and after the retrofit was evaluated using Turkish seismic code (2007) standards, and the results were compared in terms of stiffness, strength, and deformability. The results have confirmed the effectiveness of the proposed retrofit scheme. In order to make this retrofit method easy to comprehend for civil engineers a real structure from Zeytinburnu is chosen to test the panels in a computer environment. Performance of the structure evaluated in the same way and effectiveness of the panels have confirmed again.

## ÖZET

### BETONARME ÇERÇEVE YAPILARIN ÇELİK PANELLER KULLANILARAK GÜÇLENDİRİLMESİ

Türkiye’de yaşanan büyük depremler, düşük kalitede inşa edilmiş pek çok binada orta derecede hasara neden olabilmektedir. Hızlı ve uygun bir güçlendirme yapılmadığı durumda günler ya da haftalar sonra görülebilecek artçı şoklardan sonra, bu orta hasarlı binalar büyük hasar seviyesine hatta tamamen göçme durumuna geçebilirler. İş gücü, zaman ve para kaybına neden olabilecek geleneksel güçlendirme yöntemleri ile bu binaların güçlendirilmesi kimi zaman yeni baştan inşa edilmelerini çok daha cazip kılar. Bu çalışmada, orta hasarlı binalara uygulanabilecek, deplasman talebini azaltarak yapının sismik performansını yükseltebilecek pratik bir güçlendirme yöntemi sunulmaktadır. Bu güçlendirme yönteminde fabrikada imalatı yapılmış çelik paneller kullanılmıştır. Bu panellerin seçilmesinin başlıca sebepleri; hafiflikleri, taşıma ve inşa kolaylıklarının yanı sıra ucuz olmaları, kalıp ihtiyacının olmaması ve bu iş için özel elemana ihtiyaç duyulmamasıdır. Bu konsepti test etmek için, ½ ölçekte 3 boyutlu betonarme bir çerçeve Boğaziçi Üniversitesi Kandilli Rasathanesi ve Deprem Araştırma Enstitüsü’nde inşa edilmiş ve gerçek bir deprem kaydı altında orta hasar seviyesine ulaşınca kadar test edilmiştir. Daha sonra hasarlı durumdaki betonarme çerçeve çelik panellerle güçlendirilmiş ve aynı deprem kaydı altında test edilmiştir. Numunenin güçlendirmeden önceki ve sonraki performansı Deprem Yönetmeliği (2007)’ye göre değerlendirilmiştir. Sonuçlar önerilen sistemin yararlılığını doğrulamaktadır. Ayrıca inşaat mühendisleri açısından daha kolay anlaşılabilmesi için paneller, Zeytinburnu’nda mevcut orta hasarlı bir binaya bilgisayar ortamında uygulanmış benzer şekilde performansı değerlendirilmiş ve tatmin edici sonuçlara ulaşılmıştır.

## TABLE OF CONTENTS

ACKNOWLEDGEMENTS .....	iv
ABSTRACT .....	v
ÖZET .....	vi
LIST OF FIGURES .....	ix
LIST OF TABLES .....	xii
LIST OF SYMBOLS / ABBREVIATIONS .....	xiii
1. INTRODUCTION .....	1
1.1. Global Retrofit .....	3
1.1.2. Addition of RC Structural Walls .....	4
1.1.3. Use of Steel Bracing .....	4
1.1.4. Seismic Isolation .....	5
1.1.5. Supplemental Energy Dissipation .....	6
1.2. Local Retrofit .....	7
1.2.1. Column Jacketing .....	7
1.2.2. Slab Column Connection Retrofits .....	9
1.3. Selected Technique .....	9
2. SHAKING TABLE TESTS .....	12
2.1. Test Specimen and Test Setup .....	12
2.2. Testing and Results .....	14
2.3. Drift Check of Test Specimen .....	20
3. MODELLING IN SAP2000 .....	21
3.1. Model Before Retrofit .....	21
3.1.1. Section Materials .....	22
3.1.2. Loadings .....	23
3.2. Xtract Model for Retrofit .....	28
3.3. Sap2000 Model for Retrofitted Frame .....	29
3.4. Drift Check According to SAP 2000 Results .....	31
4. BUILDING EXAMPLE .....	32
4.1. Seismic Evaluation of an Existing Building with Increasing Equivalent Earthquake Load Method .....	33
4.2. Bending Rigidities for Cracked Sections .....	35

4.3. Describing Section Materials .....	36
4.4. Describing Plastic Sections for Columns.....	37
4.5. Nonlinear Pushover Analysis under Sustained Loads .....	45
4.6. Performing Criteria of Increasing Equivalent Seismic Load Method .....	45
4.7. Obtaining Pushover Curve .....	46
4.8. Obtaining Modal Capacity Diagram and Capacity Curve .....	46
4.9. Calculation of Demanded Displacement.....	48
4.10. Second Pushover Analysis .....	50
4.11. Obtaining Modal Capacity Diagram.....	50
4.12. Calculation of Spectral Displacement.....	52
4.13. Determining Performance Level of the Building .....	55
4.14. Total Curvature Calculation .....	56
4.15. Assessment of Performance Level.....	60
4.16. Seismic Evaluation Retrofitted Building with Increasing Equivalent Earthquake Load Method .....	60
4.17. Describing Plastic Sections for Steel Plates.....	62
4.18. Nonlinear Pushover Analysis under Sustained Loads .....	63
4.19. Performing Criteria of Increasing Equivalent Seismic Load Method .....	63
4.20. Pushover Analysis .....	64
4.21. Obtaining Modal Capacity Diagram.....	64
4.22. Calculation of Spectral Displacement.....	65
4.23. Determining Performance Level of the Building .....	68
4.24. Assessment of Performance Level.....	72
5. CONCLUSIONS .....	73
REFERENCES.....	74

## LIST OF FIGURES

Figure 1.1. Collapse due to shear failure in columns (1992 Erzincan Earthquake) .....	1
Figure 1.2. Collapse due to soft storey (1995 Dinar Earthquake) .....	2
Figure 1.3. Selection of the retrofit scheme .....	2
Figure 1.4. Global modification of the structural system .....	3
Figure 1.5. Local modification of the structural system .....	3
Figure 1.6. Seismic isolation systems .....	5
Figure 1.7. Supplemental energy dissipation devices .....	7
Figure 1.8. Reinforced concrete jacketing in-situ view .....	8
Figure 1.9. Reinforced concrete jacketing in- schematic view .....	8
Figure 1.10. Retrofitted slab-column connections.....	9
Figure 1.11. Three alternatives to apply according with the architectural plan .....	11
Figure 2.1. Test specimen and cross section details .....	12
Figure 2.2. Testing setup.....	13
Figure 2.3. Shake table time history .....	14
Figure 2.4. Base shear -top displacement for frames before retrofit .....	15
Figure 2.5. Retrofitted specimen .....	16
Figure 2.6. Base shear -top displacement for retrofitted frames .....	16
Figure 2.7. RC column rotations before retrofit .....	17
Figure 2.8. RC column rotations after retrofit.....	17
Figure 2.9. Measuring plastic rotations occurred in the system.....	18
Figure 2.10. Base shear -top displacement for retrofitted frames under 0.56g.....	18
Figure 2.11. Shear failure occurred in the upper connection .....	19
Figure 3.1. Xtract model .....	21
Figure 3.2. Unconfined concrete material properties .....	22
Figure 3.3. S220 Material properties .....	22
Figure 3.4. Confined concrete material properties .....	23
Figure 3.5. Column section p-m relationship for 0° .....	23
Figure 3.6. Column section p-m relationship for 45° .....	24
Figure 3.7. Sap 2000 joint numbers of 2-D model .....	24
Figure 3.8. Scaled el-centro earthquake $acc_{max} = 0.33g$ .....	25
Figure 3.9. El-centro earthquake $acc_{max} = 0.33g$ .....	25

Figure 3.10. Base shear – top displacement hysteresis in sap2000 .....	26
Figure 3.11. Base shear vs top displacement curve for one bare frame in sap2000.....	26
Figure 3.12. Column rotations before retrofit taken from sap2000.....	27
Figure 3.13. Column rotations after retrofit taken from sap2000.....	28
Figure 3.14. Xtract model of retrofitting plates.....	29
Figure 3.15. P-M interaction diagram of steel plates.....	29
Figure 3.16. Sap2000 plate section.....	29
Figure 3.17. Base shear vs top displacement curve for one retrofitted frame in sap2000..	30
Figure 4.1. Position of selected building.....	32
Figure 4.2. Floor plan.....	34
Figure 4.3. Unconfined concrete model.....	36
Figure 4.4. Steel model .....	37
Figure 4.5. 40x25 column p-m relationship for 0° .....	38
Figure 4.6. 40x25 column p-m relationship for 45° .....	38
Figure 4.7. 55x25 column p-m relationship for 0° .....	39
Figure 4.8. 55x25 column p-m relationship for 45° .....	39
Figure 4.9. 50x25 column p-m relationship for 0° .....	40
Figure 4.10. 50x25 column p-m relationship for 45° .....	40
Figure 4.11. 25x60 column p-m relationship for 0° .....	41
Figure 4.12. 25x60 column p-m relationship for 45° .....	41
Figure 4.13. 25x50 column p-m relationship for 0° .....	42
Figure 4.14. 25x50 column p-m relationship for 45° .....	42
Figure 4.15. 25x40 column p-m relationship for 0° .....	43
Figure 4.16. 25x40 column p-m relationship for 45° .....	43
Figure 4.17. 15x50 beam section moment curvature relationship.....	44
Figure 4.18. Pushover curve for x direction.....	46
Figure 4.19. Capacity curve for x direction .....	48
Figure 4.20. ADRS .....	49
Figure 4.21. Pushover curve for x direction.....	50
Figure 4.22. Capacity curve for x direction .....	52
Figure 4.23. Equal areas rule.....	53
Figure 4.24. ADRS .....	53
Figure 4.25. 4-4 axis plastic hinges. ....	54

Figure 4.26. Performance assessment of C40x25 section.....	57
Figure 4.27. Performance assessment of C25x40 section.....	57
Figure 4.28. Performance assessment of C55x25 section.....	58
Figure 4.29. Performance assessment of C25x50 section.....	58
Figure 4.30. Performance assessment of panel section .....	59
Figure 4.31. Performance assessment of C25x60 section.....	59
Figure 4.32. Damage zone assessment in Turkish seismic code.....	60
Figure 4.33. Steel panel .....	60
Figure 4.34. Floor plan with panels .....	61
Figure 4.35. P-M relationship for panels .....	62
Figure 4.36. Pushover curve for x direction.....	64
Figure 4.37. Capacity curve for x direction .....	65
Figure 4.38. Equal areas rule.....	66
Figure 4.39. ADRS .....	66
Figure 4.40. 4-4 axis plastic hinges .....	67
Figure 4.41. Performance assessment of C40x25 section.....	69
Figure 4.42. Performance assessment of C25x40 section.....	69
Figure 4.43. Performance assessment of C55x25 section.....	70
Figure 4.44. Performance assessment of C50x25 section.....	70
Figure 4.45. Performance assessment of C25x50 section.....	71
Figure 4.46. Performance assessment of C25x60 section.....	71
Figure 4.47. Performance assessment of plate section .....	72
Figure 4.48. Damage zone assessment in Turkish seismic code.....	72

## LIST OF TABLES

Table 2.1.	Natural periods of test specimen.....	19
Table 2.2.	Performance limit calculation.....	20
Table 2.3.	Turkish earthquake resistant design code story drift limits.....	20
Table 3.1.	Comparing results of SAP 2000 and test for bare frame.....	27
Table 3.2.	Base shear and top displacement values of bare frame.....	28
Table 3.3.	Base shear and top displacement values of bare frame.....	30
Table 3.4.	Performance limit calculation.....	31
Table 4.1.	General characteristics of the building.....	33
Table 4.2.	Participated mass ratios belongs to the first natural period in x direction .....	45
Table 4.3.	Calculation of capacity diagram coordinates.....	47
Table 4.4.	Calculation of capacity diagram coordinates.....	51
Table 4.5.	Calculation of nonlinear spectral displacement .....	54
Table 4.6.	Strain limits.....	55
Table 4.7.	Example of total curvature calculation.....	56
Table 4.8.	Participated mass ratios belongs to the first natural period in x direction .....	63
Table 4.9.	Calculation of capacity diagram coordinates.....	64
Table 4.10.	Calculation of nonlinear spectral displacement .....	67
Table 4.11.	Example of total curvature calculation.....	68

## LIST OF SYMBOLS / ABBREVIATIONS

$ADRS$	acceleration displacement response spectra
$A_0$	effective ground acceleration coefficient
$A(T)$	spectral acceleration coefficient
$a_1(i)$	modal acceleration belongs to first mode
$(EI)_e$	cracked section bending rigidity
$(EI)_o$	section bending rigidity
$f_{cd}$	design compressive strength of concrete
$f_{ck}$	characteristic compressive cylinder strength of concrete
$f_{ctd}$	design tensile strength of concrete
$f_{yd}$	design yield strength of longitudinal reinforcement
$f_{yk}$	characteristic yield strength of longitudinal reinforcement
$n$	live load participation factor
$R$	structural behavior factor
$R_d(T)$	seismic load reduction factor
$S(T)$	spectrum coefficient
$T$	building natural vibration period
$T_A, T_B$	spectrum characteristic periods
$V_t$	in the equivalent seismic load method, total equivalent seismic load acting on the building.
$W$	total weight of the building calculated by considering live load participation factor
$\Delta_i$	story drift of $i$ 'th storey of building
$\Phi_t$	total curvature demand
$\Phi_p$	plastic curvature demand
$\Phi_y$	equivalent yielding demand
$\Gamma_{x1}$	modal participation factor belongs to the first mode

## 1. INTRODUCTION

The 1939 and 1992 earthquakes in Erzincan, the 1943 earthquake in Adapazarı, Hendek, the 1995 earthquake in Dinar, the 1998 earthquake in Adana, Ceyhan, and the 1999 earthquake in Düzce led to significant changes in the practice of seismic design, particularly in the high seismic regions of Turkey.

Prior to these events, most of the existing reinforced concrete structures were typically designed primarily for gravity loads and lateral forces that may be much smaller than that prescribed by the current codes. Also due to inadequate lap splice in the longitudinal reinforcements, lack of confinement in flexural hinge zones these deficiencies can significantly reduce the strength and ductility of a column (**Aboutaha, 1996**). While these existing structures were very vulnerable to seismic action even if located in areas that have long been considered of high seismic hazard, they were not able to withstand the ductility demand by the earthquake against the supplied strength some modifications should be adapted to the existing system in order to improve the structural performance.



Figure 1.1. Collapse due to shear failure in columns (1992 Erzincan Earthquake)



Figure 1.2. Collapse due to soft storey (1995 Dinar Earthquake)

A number of techniques may be used to retrofit concrete structures. Retrofitting may be carried out on a globally and locally while taking into account the selection scheme mentioned below.

#### Technical & Socio-economic issues

- |                             |                    |
|-----------------------------|--------------------|
| ✓ Structural compatibility  | ✓ Workmanship      |
| ✓ Materials/Technology      | ✓ Quality control  |
| ✓ Foundation system         | ✓ Duration of work |
| ✓ Structural irregularities | ✓ Functionality    |
| ✓ Cost vs importance        |                    |

Figure 1.3. Selection of the retrofit scheme

Global retrofitting is based on strength and stiffness, which involves global modifications to the structural system. Common global modifications include the addition of structural walls, steel braces, or base isolators. The other one local retrofitting is based on deformation capacity. In this approach, the ductility of components with inadequate capacities is increased to satisfy their specific limit states.

The member-level retrofit includes methods such as the addition of concrete, steel, or fiber reinforced polymer jackets to columns for confinement.

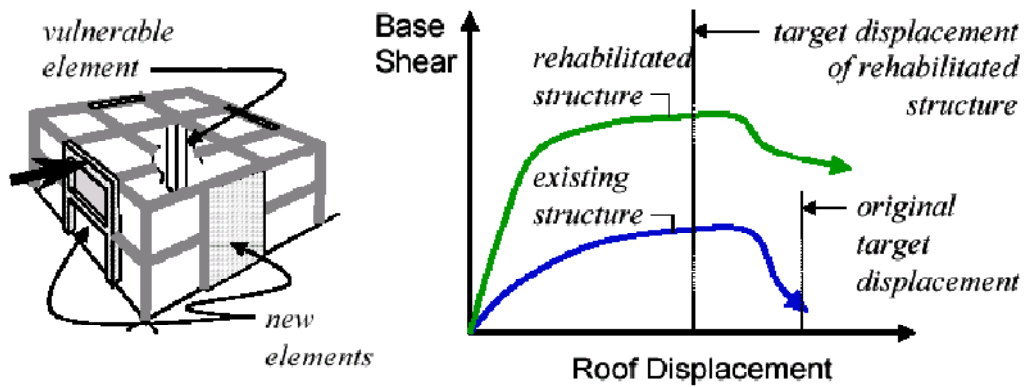

Figure 1.4. Global modification of the structural system

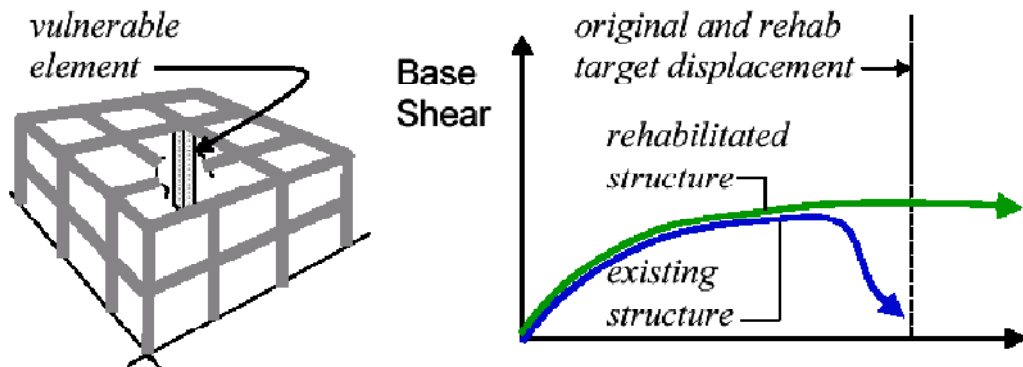

Figure 1.5. Local modification of the structural system

### 1.1. Global Retrofit

Structure-level retrofits are commonly used to enhance the lateral resistance of existing structures. Such retrofits for RC buildings include steel braces, post-tensioned cables, infill walls, shear walls, masonry infills, and base isolators. The methods described below are commonly used when implementing a structure-level retrofit technique.

### **1.1.2. Addition of RC Structural Walls**

Adding structural walls is one of the most common global retrofitting methods to strengthen existing structures. This approach is effective for controlling global lateral drifts and for reducing damage in frame members. Generally, repair of an existing shear wall or infilling one of the bays in the frame structure is used. In order to reduce time and cost, shotcrete or precast panels can be used. Many research studies have been conducted for structural walls, and findings corresponding to detailed interventions have been reported. The research shows that with the infilling process, details play an important role in the response of panels and the overall structure. The infilling process tends to stiffen the structure such that the base shear can increase. The overturning effects and base shear are concentrated at the stiffer infill locations. Therefore, strengthening of the foundation is typically required at these locations.

### **1.1.3. Use of Steel Bracing**

The addition of steel bracing can be effective for the global strengthening and stiffening of existing buildings. Concentric or eccentric bracing schemes can be used in selected bays of an RC frame to increase the lateral resistance of the structure. The advantage of this method is that an intervention of the foundation may not be required because steel bracings are usually installed between existing members. Increased loading on the existing foundation is possible at the bracing locations and so the foundation still must be evaluated. In addition, the connection between the existing concrete frame and the bracing elements should be carefully treated because the connection is vulnerable during earthquakes. Several researchers have reported successful results when using steel bracing to upgrade RC structures. Braces in tension tend to stretch and become slack when the load is removed. Subsequent loading cycles may be applied abruptly and may cause the premature failure of the braces. This condition can be alleviated by using high strength materials, such as 25 alloy steel strands, and/or initially prestressing the braces. Prestressed high slenderness ratio braces, also referred to as post-tensioned bracing systems, increase the initial lateral

stiffness of the frame and allow the braces to yield in tension without becoming slack upon removal of the load.

#### 1.1.4. Seismic Isolation

The seismic isolation, mainly considered for buildings and bridges, consists in setting a device which is flexible in the horizontal direction and very stiff in the vertical direction. Isolation systems are generally located between the foundation and the main structure. The main objective of the seismic isolation is to release the structures from the influence of ground accelerations using foundations that are flexible in the horizontal directions. The net effect is a reduction of the energy dissipation demand of the structural system, resulting in an increase of its performance. The base isolation technique has been used successfully worldwide in many buildings and other structures for earthquake protection. Although behavior of isolated buildings is satisfactory during the earthquakes, the large displacements at isolation level remain the foremost disadvantage. Due to insufficient or improper separation gap distances provided or occurrence of stronger than predicted design earthquake, especially at near fault locations, the base isolated buildings may collide upon the adjacent structures. Therefore it is imperative to investigate the response of base isolated buildings to the impact with the adjacent structures. The superstructure flexibility and isolator characteristic are crucial factors in the design of base isolated buildings.

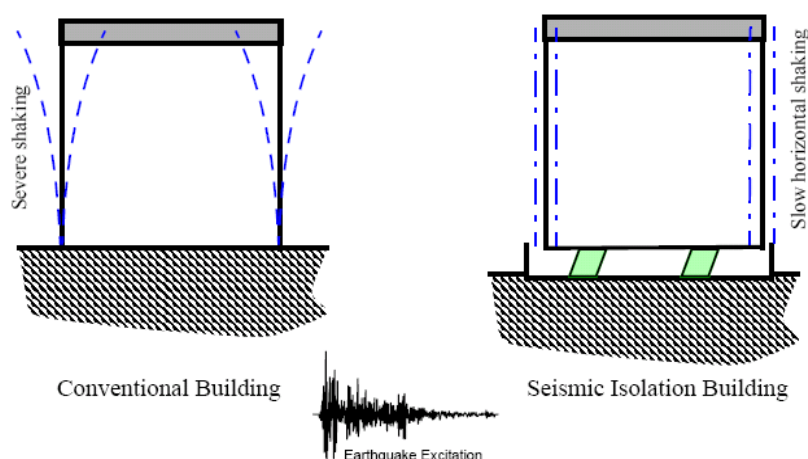

Figure 1.6. Seismic isolation systems

### **1.1.5. Supplemental Energy Dissipation**

An alternative and often more cost efficient retrofitting strategy compared to base isolation is installation of supplemental energy dissipation devices in structures as a means for passive or active structural control. The objective of structural control is to reduce structural vibrations for improved safety and/or serviceability under wind and earthquake loadings. Passive control systems reduce structural vibration and associated forces through energy dissipation devices that do not require external power. These devices utilize the motion of the structure to develop counteracting control forces and absorb a portion of the input seismic energy. Active control systems, however, enhance structural response through control forces developed by force delivery devices that rely on external power to operate. The actuator forces are controlled by real time controllers that process the information obtained from sensors within the structure. The severity of seismic demand on a structure is proportional to its stiffness and inversely proportional to its damping or energy dissipation capacity. Thus, installing supplemental energy dissipating devices in the structure reduces the seismic demand and results in increased safety of the structure and its contents from the damaging effects of earthquakes. A special concern regarding the use of energy dissipation devices in structures with high characteristic variability is the fact that the effectiveness of such devices is dependent on the deformation capacity of the structure. For structures that suffer from inadequate seismic detailing, which translates into insufficient deformation capacity, great caution must be exercised in use of these devices for seismic retrofitting. A feasible solution may be to combine this technique with deformation enhancement measures to ensure their effectiveness. This constitutes an important research area with valuable potential contribution and high potential benefits. On the other hand, FEMA356 (FEMA356,2000) discusses some negative aspects. While lateral displacements are reduced through the use of supplemental energy dissipation, the forces in the structure can increase not really if designed properly.

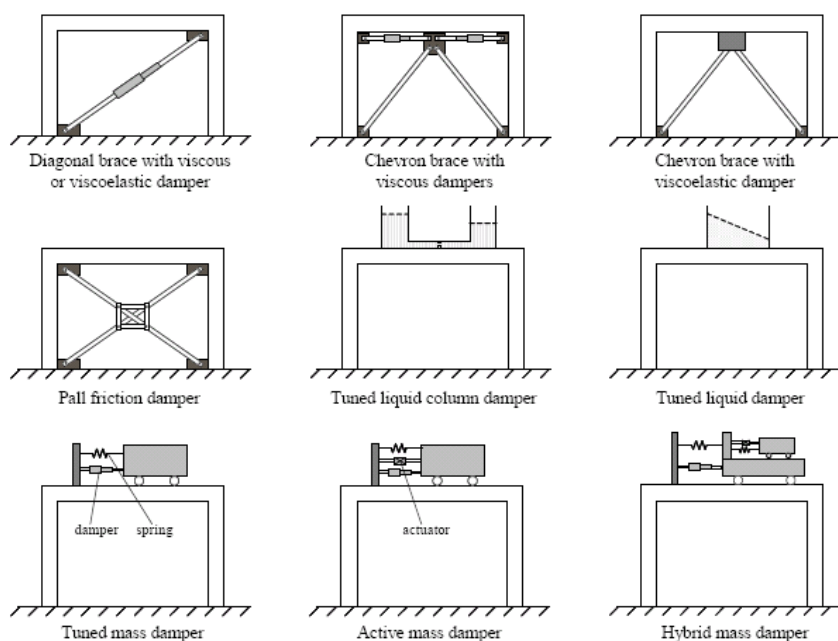

Figure 1.7. Supplemental energy dissipation devices

## 1.2. Local Retrofit

The member level retrofit approaches include the addition of concrete, steel, or fiber reinforced polymer jackets for use in confining RC columns and joints. In particular, in flat slab structures, punching shear failures are likely to occur if the slab is not designed for the combined effects of lateral and gravity loads. Therefore, local retrofits are mainly performed on slab-column connections.

### 1.2.1. Column Jacketing

Column retrofitting is often critical to the seismic performance of a structure. To prevent a story mechanism during an earthquake, columns should never be the weakest components in the building structure. The response of a column in a building structure is controlled by its combined axial load, flexure, and shear. Therefore, column jacketing may be used to increase strength so that columns are not damaged (**Bracci, 1995**).

It is very important to achieve an adequate anchorage between the existing ones and new columns. Welding is not necessary; however chipping off the concrete cover in

the existing column is required. Connection by means of bent bars welded to the vertical reinforcement. The concrete must be chipped off locally, in order to expose the vertical reinforcement bars in the areas where bent bars are going to be provided. In this way, concrete keys capable of transmitting shear forces are formed and the force transfer between the existing and the new concrete is achieved. The concrete cover in the tie region must be removed and each new tie must be welded to the existing one.



Figure 1.8. Reinforced concrete jacketing in-situ view

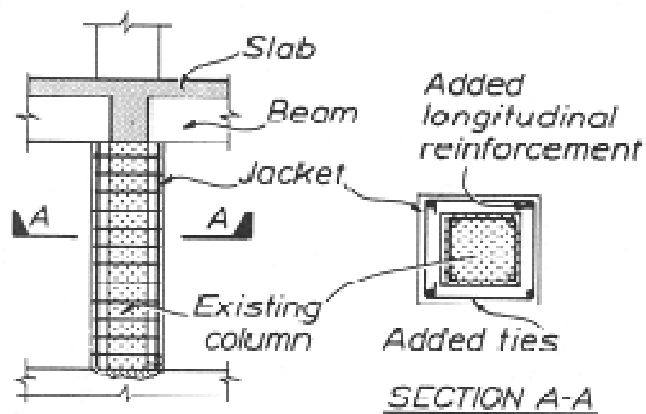

Figure 1.9. Reinforced concrete jacketing in- schematic view

### 1.2.2. Slab Column Connection Retrofits

In slab-column connections, punching shear failure due to the transfer of unbalanced moments is the most critical type of structural damage. The retrofitting of slab-column connections is beneficial for the prevention of punching shear failures.

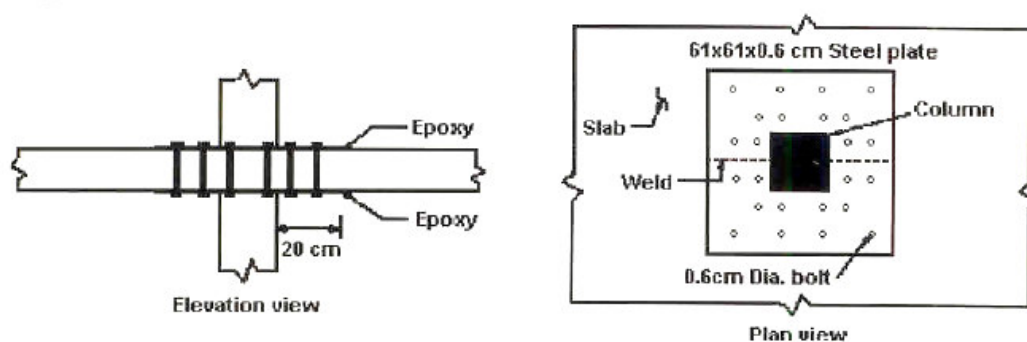

Figure 1.10. Retrofitted Slab-Column Connections

### 1.3. Selected Technique

Decision of retrofit or reconstruction needs a detailed study which may consume a considerable time period. Hence, an effective, fast, and economical solution is needed to rehabilitate deficient structures in order to avoid the severe damages or total collapse of these structures during earthquakes or aftershocks; thus saving lives and decreasing the need for shelter.

In this study brief introduction about the behavior of SPSW and the tests is presented.

The use of SPSW systems in reinforced concrete structures are needed first to improve the ductility of the reinforced structural members. In order to dissipate the energy by hysteresis damping of the SPSW the structure should go very high inter story displacement up to 2-5% and if the reinforced concrete columns are not ductile it will fail before it reaches this high displacement level.

Using thin steel plates with □ shape profiles is proposed to form steel panel which can be inserted in the mid of the bay of the reinforced concrete frame, to increase the stiffness of the structure and as a result resists considerable amount of the lateral forces caused by the earthquake as a result it is expected that the inter story drift to reduce existing nonductile structure can withstand this reduced drift.

The use of the proposed steel panel in retrofitting existing reinforced concrete building has the following advantages;

- (1) The panels are fabricated in the factory and it is easy to put in place reducing the construction cost.
- (2) It does not need any formwork in the case of reinforced concrete shear walls.
- (3) No need to evacuate the residence.
- (4) It can be installed in a short time compared with the other retrofit methods.
- (5) It does not add heavy weights to the structure compared with reinforced concrete shear walls.
- (6) It is cheaper compared with the traditional retrofitting methods such as using fiber reinforced plastics, dampers and etc.
- (7) Panels can be inserted without changing the architectural plan.
- (8) It increases the damping of the existing reinforced concrete structure.

In this research thin steel plates are proposed for temporary retrofitting of these non ductile reinforced concrete frame structures. Actually, the most important reason why the steel plate shear walls have been preferred as a lateral load-resisting system is that they have superior ductility, a robust resistance to degradation under cyclic loading, high initial stiffness, and when moment-resisting beam to column connections are present, inherent redundancy and a capacity for significant energy dissipation. Therefore, such systems can also be used for strengthening of steel buildings.

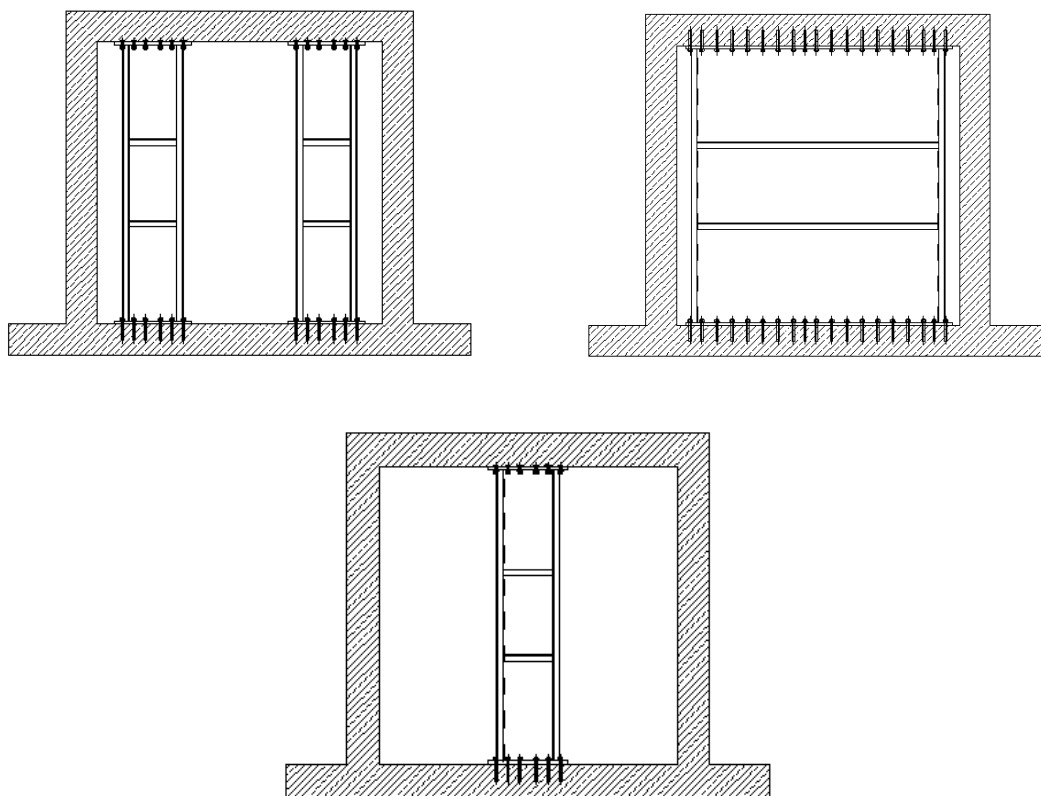

Figure 1.11. Three alternatives to apply according with the architectural plan

## 2. SHAKING TABLE TESTS

### 2.1. Test Specimen and Test Setup

Two identical one story  $\frac{1}{2}$  scale reinforced concrete bare frame specimens were constructed in the laboratory and cast at the same time using same concrete mix, to ensure identical concrete properties. Average compressive strength of concrete obtained from standard cylinder tests after 28 days was 16 Mpa. Each RC frame specimen had an identical reinforcement layout. No 8 bars with  $50 \text{ mm}^2$  cross-sectional area and 8 mm nominal diameter were used as longitudinal reinforcement. The stirrups were 8 mm in diameter and it was 100 mm spaced. After concrete harden the frames were connected by I-shape steel beams to form 3D model specimen shown in Figure.2.1.

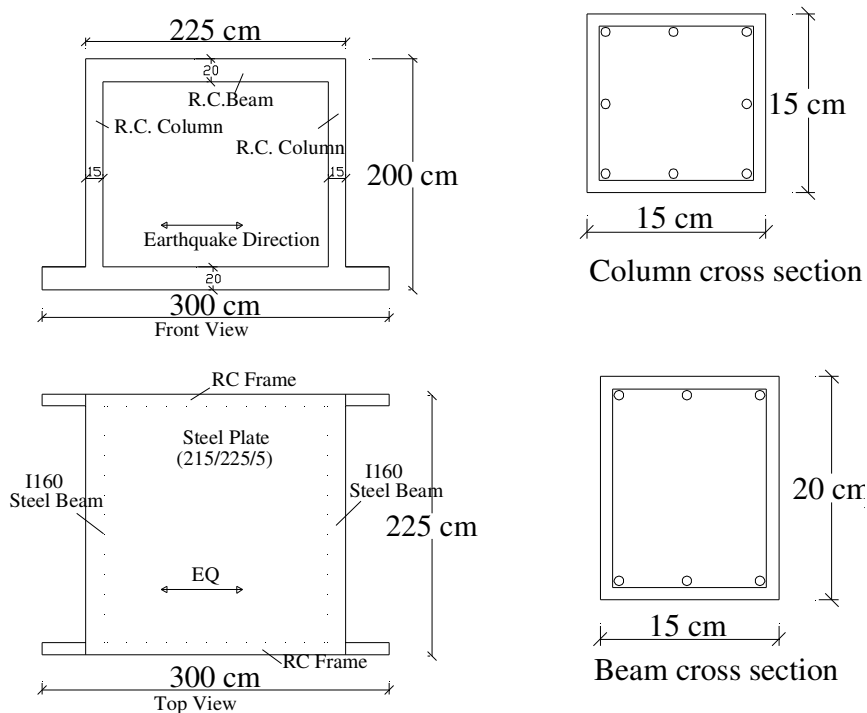

Figure 2.1. Test specimen and cross section details

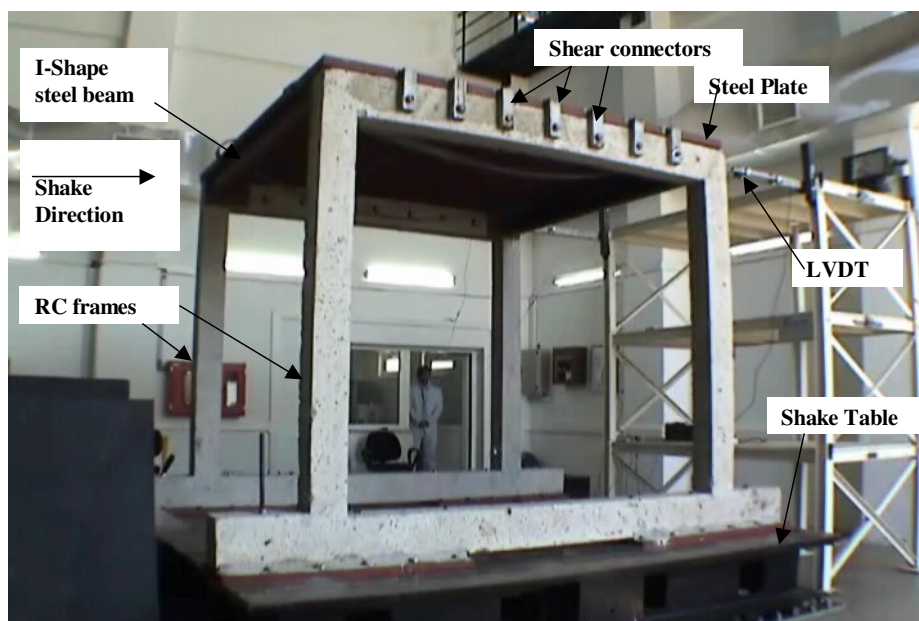

Figure 2.2. Testing Setup

Taking into account the similitude requirements, the artificial mass simulation has been applied as a method for model design of the specimen. Accordingly to simulate the mass of the model the beams of the RC frames were connected to 50mm thick steel plate by means of shear connectors. Bogazici University shaking table on which the 3D model specimen were installed is used to impose uni-axial earthquake motion to the specimen. This shaking table is a uni-axial horizontal vibration shake table driven by a servo-hydraulic actuator. It is 3 m x 3 m in plan and it is capable of shaking a 10-ton payload with 2 g acceleration (i.e. two times the acceleration of gravity in the horizontal direction). The shake table is ideally suited to seismic applications, because the hydraulic actuator can produce a stroke of  $\pm 12$  cm (24 cm total stroke). The actuator has a 3-stage servo-valve controlled by an analogue inner-loop control system (displacement based), and a digital outer-loop control system (acceleration feedback based). Table motion and data acquisition are carried out by a Data Physics 550 WIN digital data control and acquisition system. Three displacement transducers (LVDT) were placed at the top of the model specimen to measure the top displacements ( i.e mid top displacements, right top displacement, and left top displacement ) and one displacement transducer were place at the shaking table level to measure the shake table displacement as shown in Figure.2.2. Seven capacitive accelerometers were placed at

several points of the specimen to measure the dynamic response of the specimen, specially the top acceleration and out of plane accelerations.

## 2.2. Testing and Results

The model specimen have been subjected to the El Centro earthquake 1940(E-W component) applied in the longitudinal direction of the specimen. Because of the similitude requirements the time scale and the intensity of earthquake records have been altered to ensure that the shaking table motion will produce the required inelastic behavior of the model. The original record consisting of 1562 points with time step of 0.02 sec has been changed to the time step increment of 0.0141 sec .So the total span of the earthquake applied on the shaking table was 22 sec. The acceleration values of the record were not scaled. The amplitude of the scaled record was increased up to (0.33 g) at which a moderate damage level was reached (i.e plastic hinges occurs in the columns), and the base shear-top displacement hysteresis loops were recorded and presented in Figure 2.4.

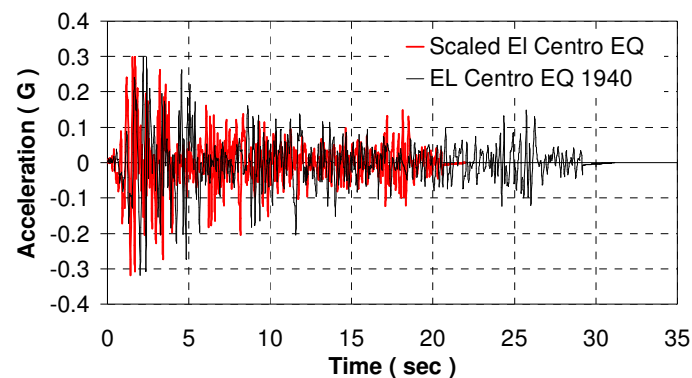

Figure 2.3. Shake table time history

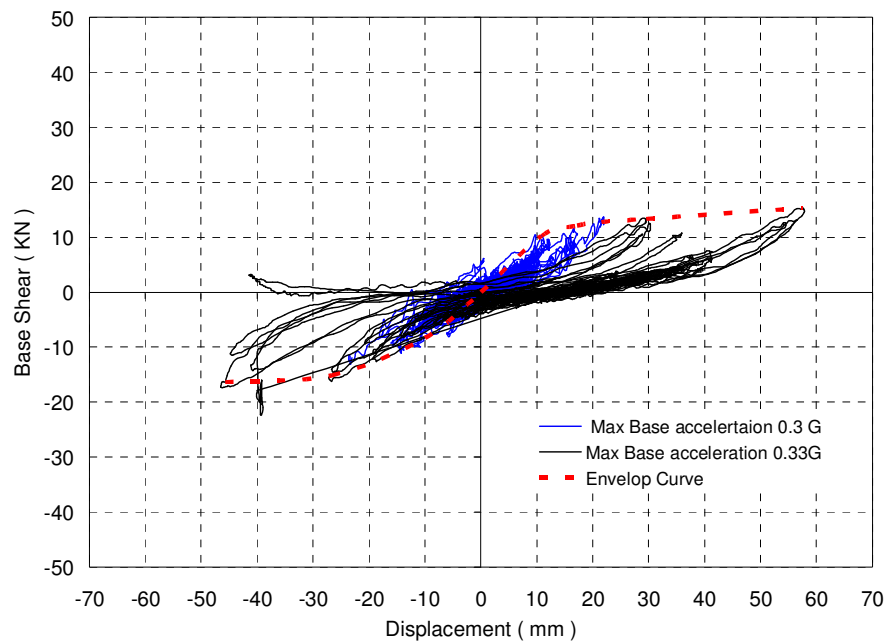

Figure 2.4. Base shear -top displacement for frames before retrofit

The moderately damaged specimen were retrofitted by adding to each RC frame two 350mm-wide fabricated steel panels near its columns and connect them with the upper and lower RC beams by means of epoxy anchored shear connectors as shown in Figure 2.5. Each steel panel was rigidly connected to the upper beam, however it was semi rigidly connected to the lower beam (i.e. base beam) by inserting a piece of rubber in between the steel panel connecting plate and the RC base beam. The retrofitted specimen were tested after one day of installation under the same scaled earthquake used before retrofitting, and the base shear - top displacement hysteresis loops were recorded and presented.

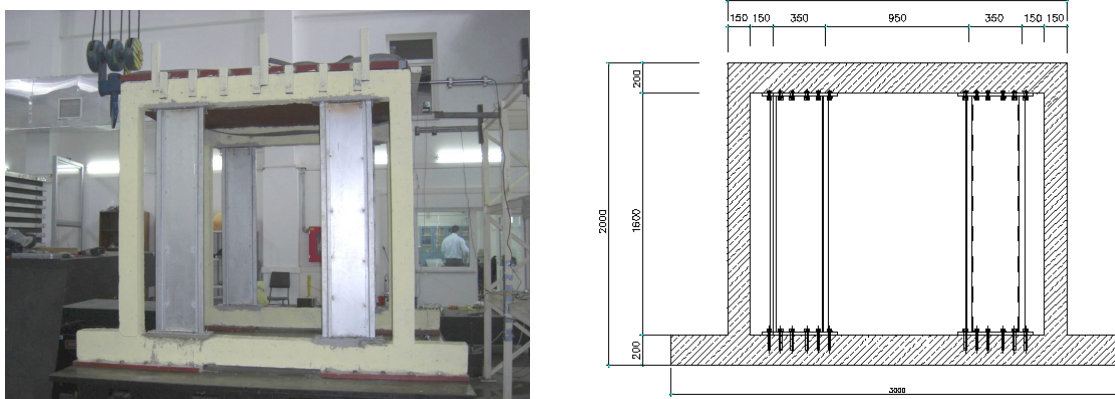

Figure 2.5. Retrofitted specimen

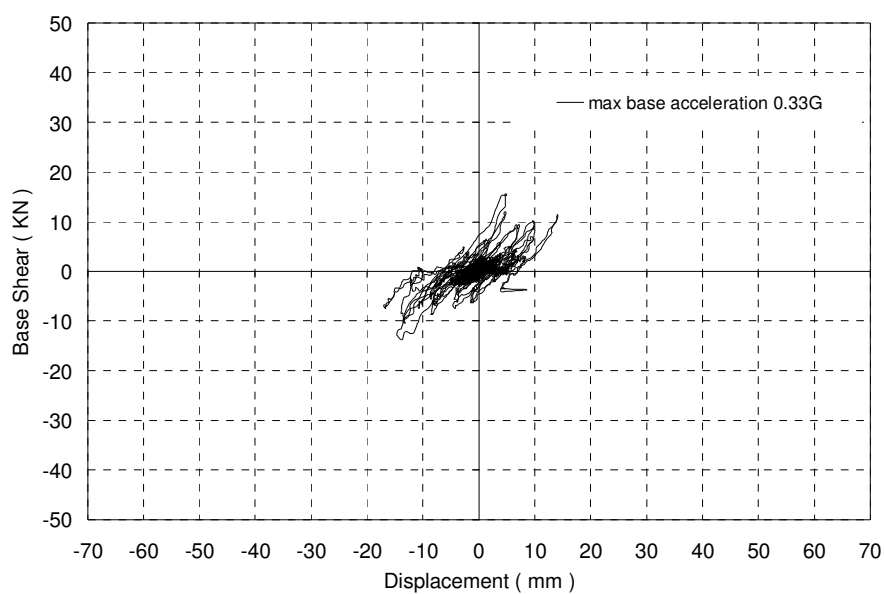

Figure 2.6. Base shear -top displacement for retrofitted frames

Also rotations of one of the RC column joint near the base were measured in order to realize, if the SAP2000 model represent well to our specimen. Non-retrofitted and retrofitted specimens and the results are plotted in Figure 2.7. and Figure 2.8. respectively.

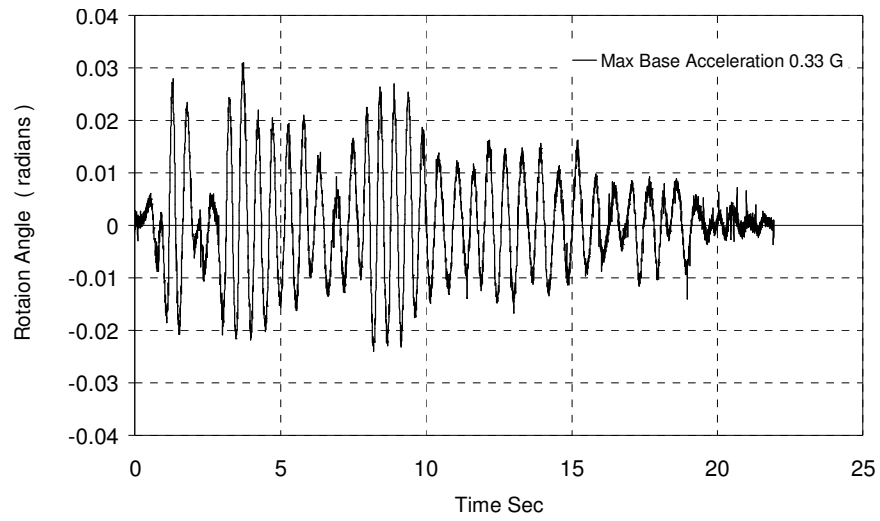

Figure 2.7. RC column rotations before retrofit

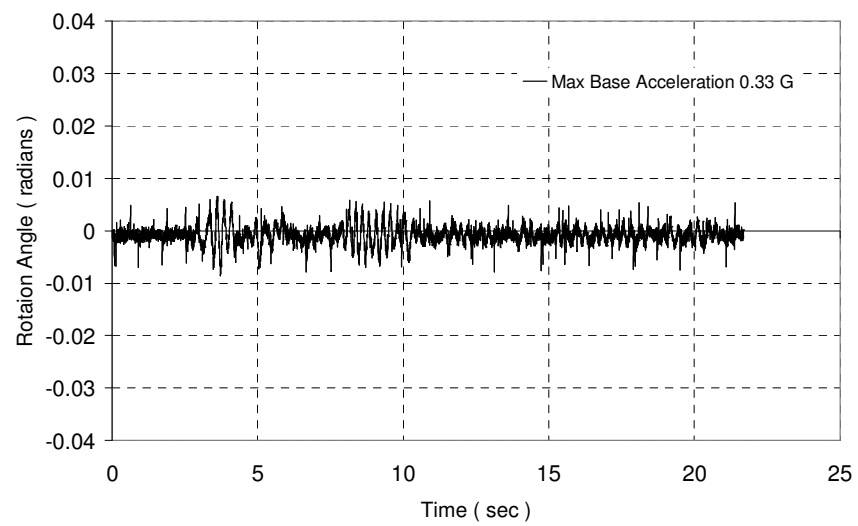

Figure 2.8. RC column rotations after retrofit



Figure 2.9. Measuring plastic rotations occurred in the system

In order to obtain the lateral load carrying capacity of the retrofitted specimen , base acceleration amplitude were increased up to 0.56g at which a shear failure occurred in the upper connection between the panels and the RC beams. In the end of tests the base shear-top displacement hysteresis curves of the retrofitted specimen were plotted and presented below.

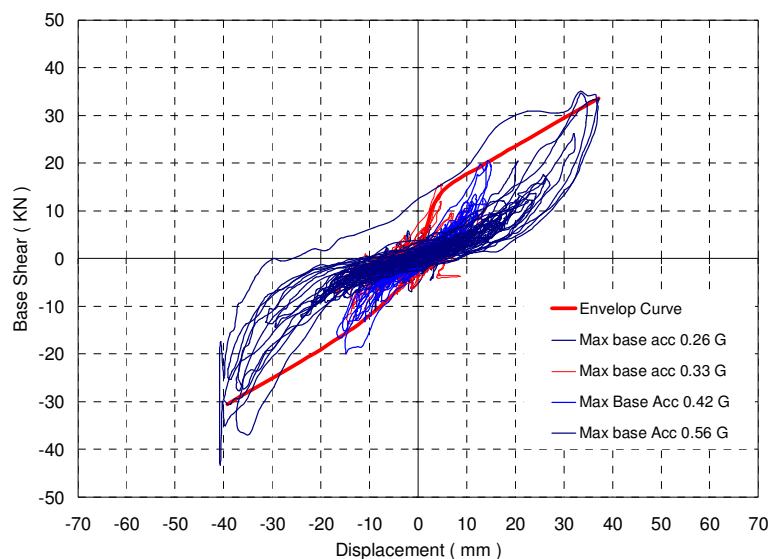

Figure 2.10. Base shear -top displacement for retrofitted frames under 0.56g



Figure 2.11. Shear failure occurred in the upper connection

Comparing the behavior of the specimen before and after retrofitting, it is clear that adding the lightweight panels to the RC frame specimen results in reduction of story drifts in half and increase the stiffness of the damaged frames. Some increase in the strength was observed as well. Free vibration tests were conducted before and after each test to measure the natural periods of the test specimen. Slight change of test specimen natural period was observed due to adding the light weight panel as shown in table below.

Table 2.1. Natural periods of test specimen

	Period Before Retrofit (sec)	Period After Retrofit (sec)
Test Specimen before damage	0.16 sec	0.12 sec
Test Specimen After damage	0.50 sec	0.40 sec

Damping of the test specimen before and after retrofit was calculated and it was 7 per cent and 28 per cent respectively.

### 2.3. Drift Check of Test Specimen

Table 2.2. Performance limit calculation

	H column (mm)	Top Displacement $\Delta$ (mm)	Drift % $\Delta/H$	Performance Limit
Before Retrofit	1800	56	0.0311	CP
After Retrofit	1800	36	0.0200	LS

Table 2.3. Turkish earthquake resistant design code story drift limits

Drift Ratio	Performance Level		
	MN	LS	CP
$(\delta_i)_{\max}/h_i$	0.008	0.02	0.03

### 3. MODELLING IN SAP2000

In order to realize how my computer model represents the specimen in the laboratory some structural properties need to be examined, so that nonlinear time history analyses applied to the computer model. Column, beam and, retrofitting plate properties represented to SAP 2000 computer program by means of XTRACT (Imbsen &Associades, Inc) computer program.

#### 3.1. Model Before Retrofit

##### Section Details:

X Centroid:	-.5864E-3 cm
Y Centroid:	2.346E-3 cm
Section Area:	225.0 cm <sup>2</sup>
El gross about X:	1.231E+6 N-m <sup>2</sup>
El gross about Y:	1.229E+6 N-m <sup>2</sup>
I trans (Confined1) about X:	4559 cm <sup>4</sup>
I trans (Confined1) about Y:	4550 cm <sup>4</sup>
Reinforcing Bar Area:	4.022 cm <sup>2</sup>
Percent Longitudinal Steel:	1.787 %
Overall Width:	15.00 cm
Overall Height:	15.00 cm
Number of Fibers:	42
Number of Bars:	8
Number of Materials:	3

##### Material Types and Names:

Unconfined Concrete:	■ c16
Strain Hardening Steel:	■ s220
Confined Concrete:	■ Confined1

##### Comments:

Section Type: Rectangular Column  
 Type of Reinforcing: Single Hoop  
 Transverse Reinforcing Bar Size: 8 mm  
 Spacing of Transverse Steel: 10.00 cm  
 Section Width: 15.00 cm  
 Section Height: 15.00 cm  
 Cover Thickness: 1.0000 cm  
 Number of Longitudinal Bars: 8  
 Longitudinal Bar Size: 8 mm  
 Cover Concrete: c16  
 Column Core Concrete: Confined1  
 Longitudinal Steel: s220

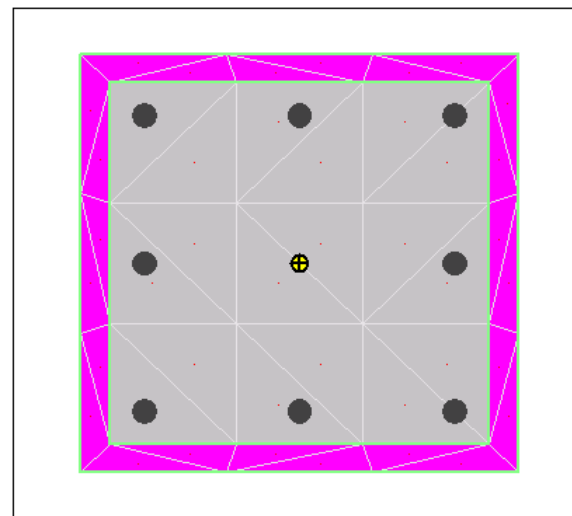

Figure 3.1. Xtract Model

### 3.1.1. Section Materials

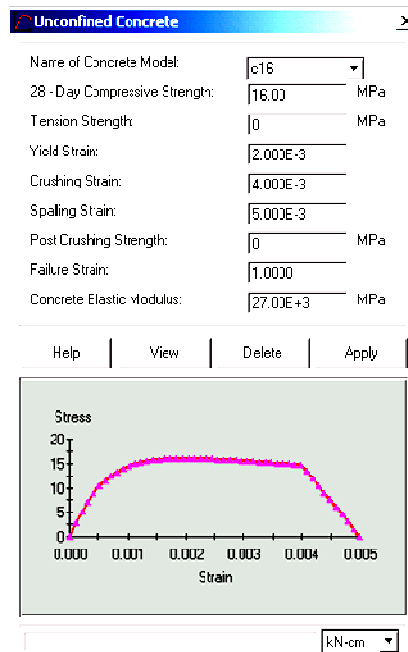

Figure 3.2. Unconfined concrete material properties

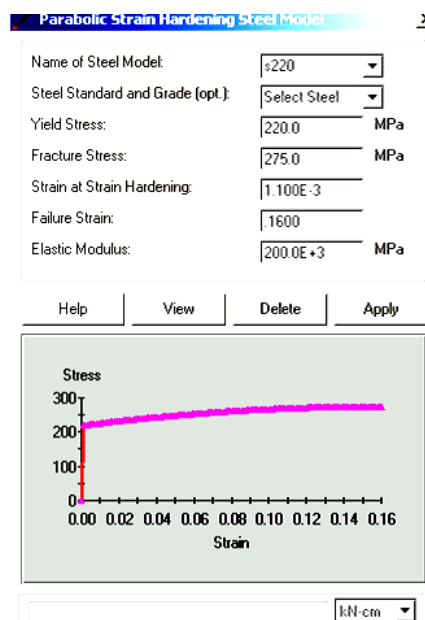

Figure 3.3. S220 Material properties

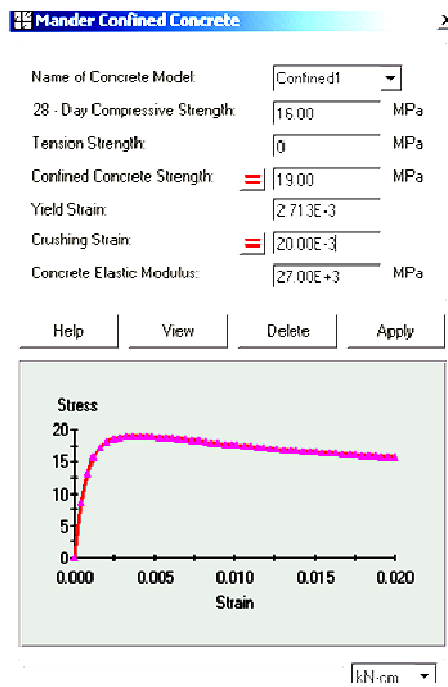

Figure 3.4. Confined concrete material properties

### 3.1.2. Loadings

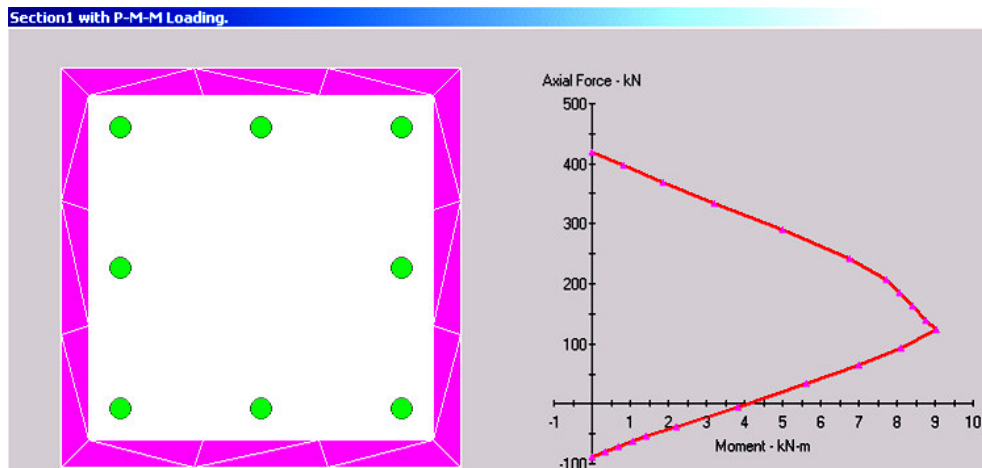

Figure 3.5. Column section p-m relationship for  $0^\circ$

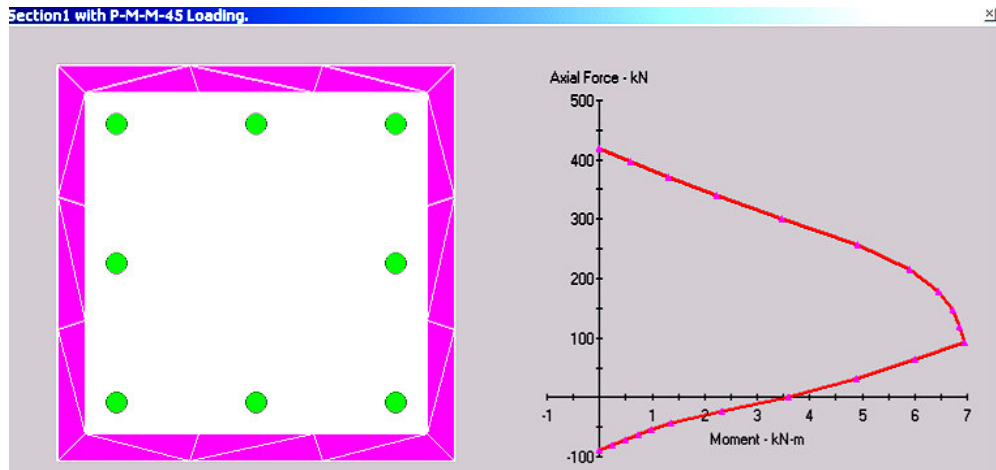

Figure 3.6. Column section p-m relationship for  $45^\circ$

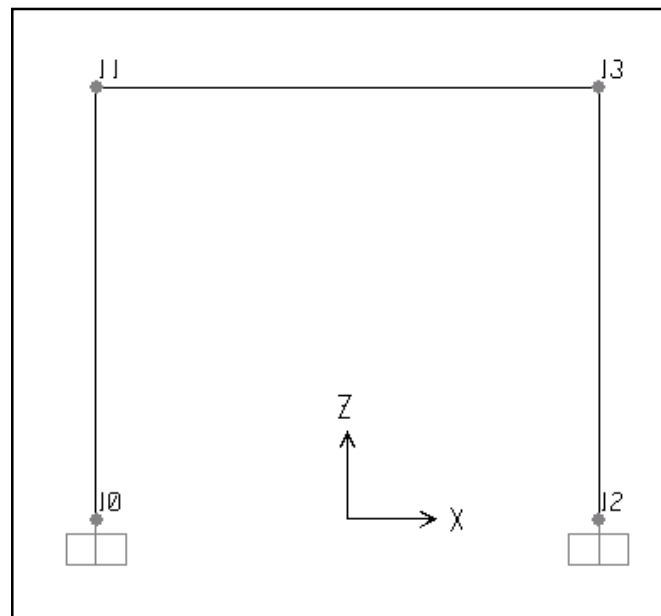

Figure 3.7. Sap 2000 joint numbers of 2-D model

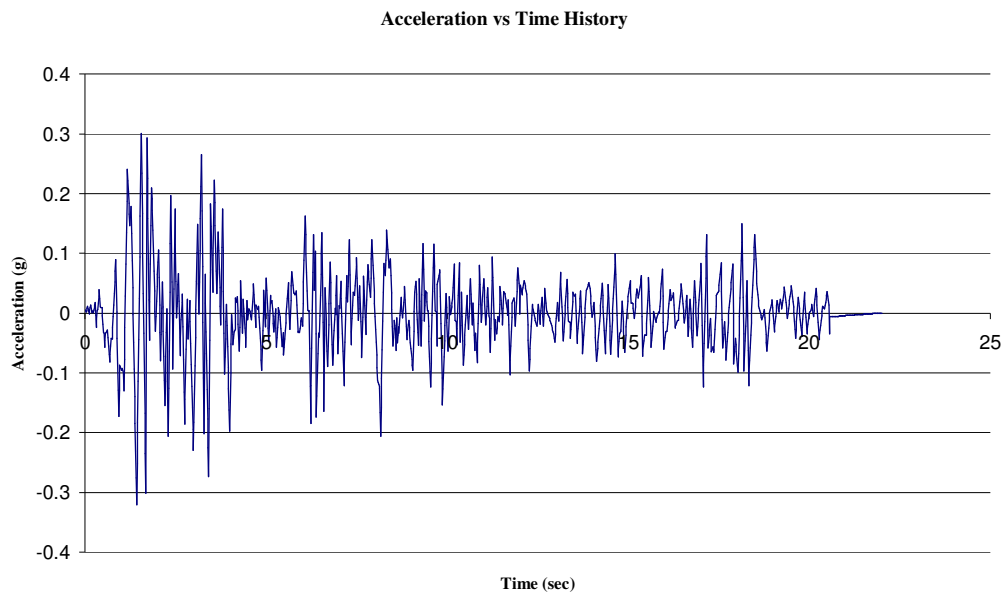

Figure 3.8. Scaled el-centro earthquake  $acc_{max} = 0.33g$

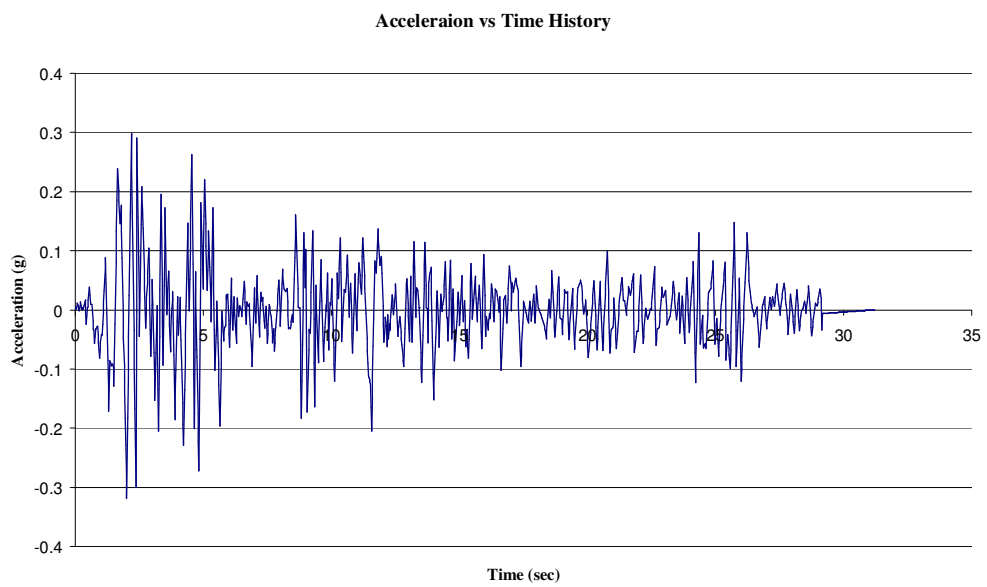

Figure 3.9. El-centro earthquake  $acc_{max} = 0.33g$

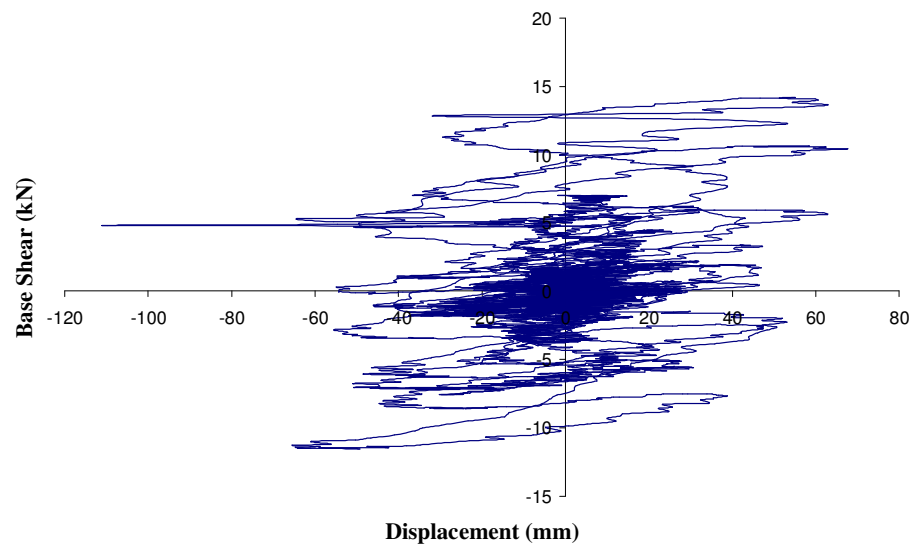

Figure 3.10. Base shear – top displacement hysteresis in sap2000

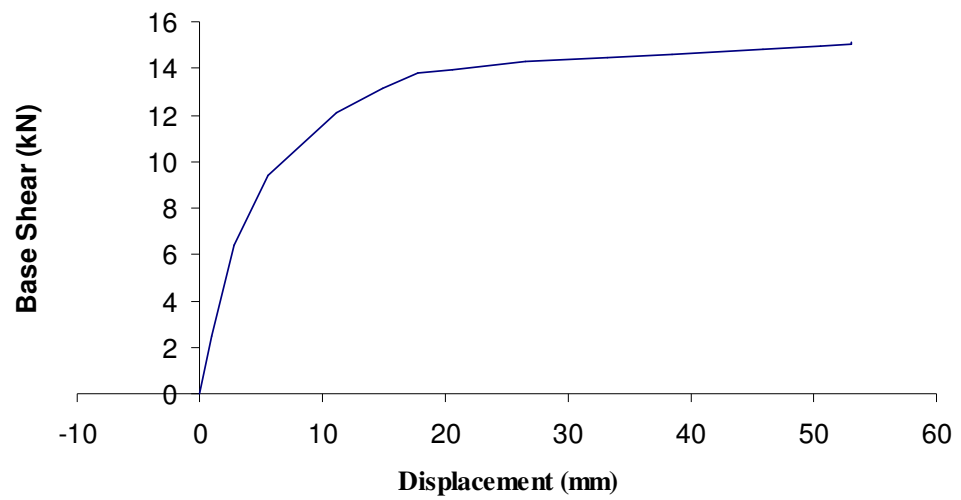

Figure 3.11. Base shear vs top displacement curve for one bare frame in sap2000

Table 3.1. Comparing results of SAP 2000 and test for bare frame

	Base Shear (kN)	Displacement (mm)
Test Specimen Before Retrofit	15.0	56.0
Computer Model Before Retrofit	14.7	54.0

Due to the fact that the values that describe the model and specimen are very similar to each other, we can say that the computer model represents well to the specimen, and we can compose the retrofitted model.

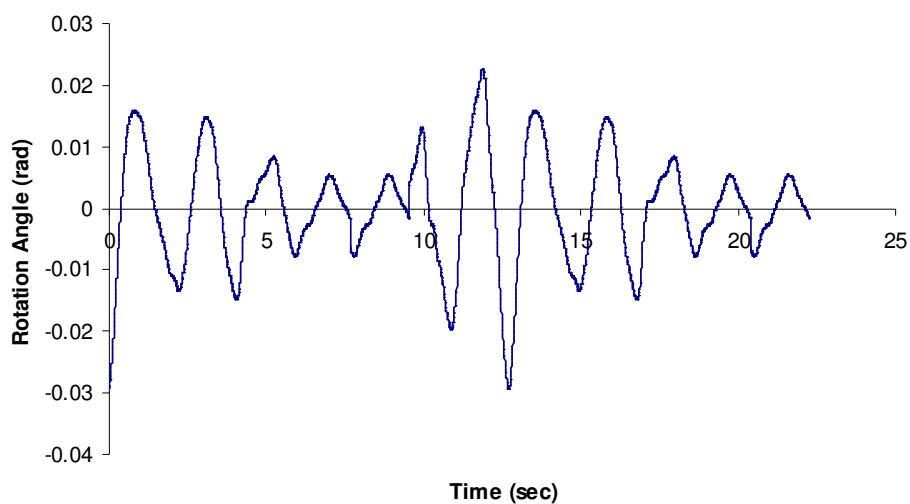

Figure 3.12. Column rotations before retrofit taken from sap2000

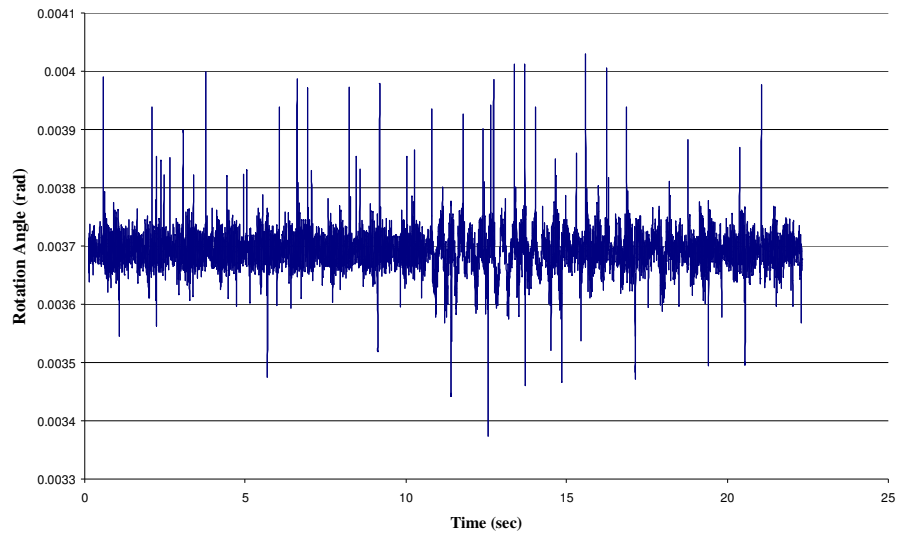

Figure 3.13. Column rotations after retrofit taken from sap2000

Table 3.2. Base shear and top displacement values of bare frame

	Before Retrofit (rad)	After Retrofit (rad)
Test Specimen Rotation	0.0320	0.005
Computer Model Rotation	0.0312	0.004

### 3.2. Xtract Model for Retrofit

In order to define steel plates and 40x40 mm square profiles its necessary to work with mm values in Xtract computer program, and it's also necessary ( due to working with very small values ) to remesh section before the analyze.

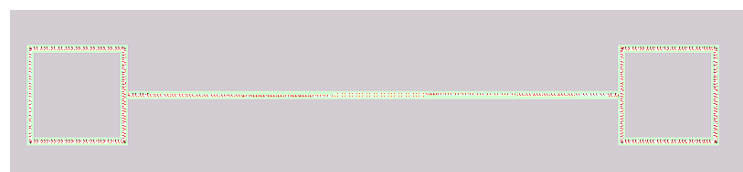

Figure 3.14. Xtract model of retrofitting plates

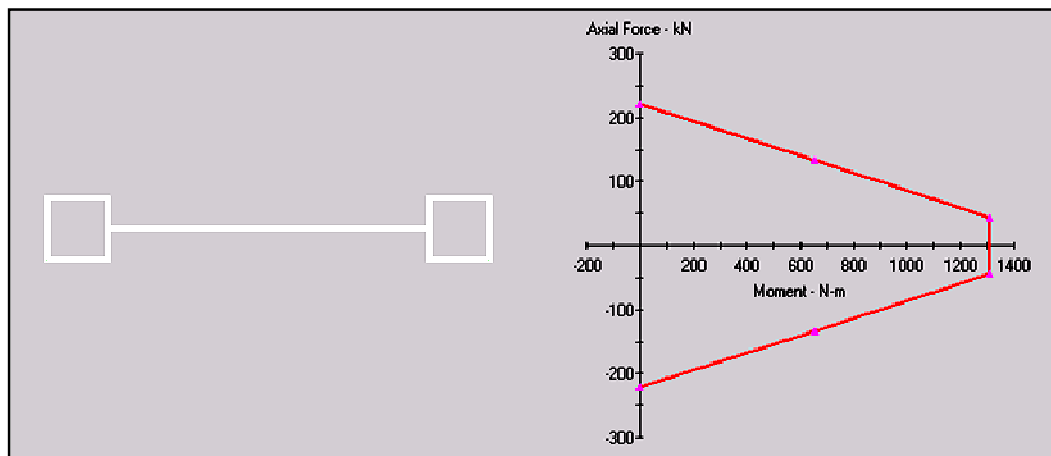

Figure 3.15. P-M interaction diagram of steel plates

### 3.3. Sap2000 Model for Retrofitted Frame

Steel plate sections introduced to the Sap2000 computer program by means of section designer like shown in the figure below.

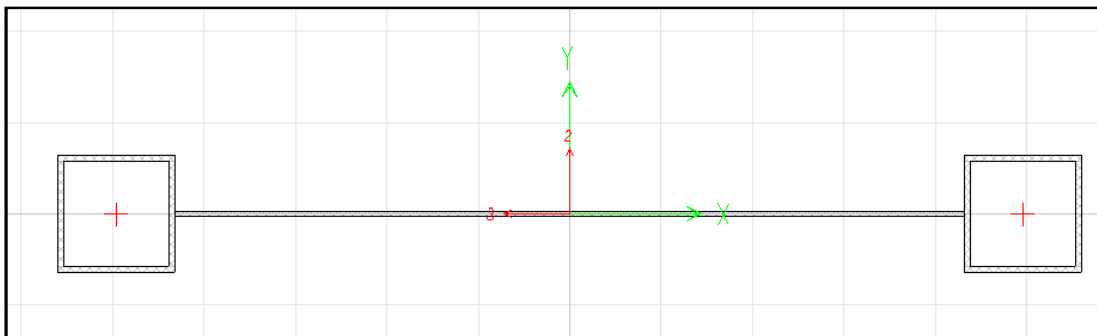

Figure 3.16. Sap2000 plate section

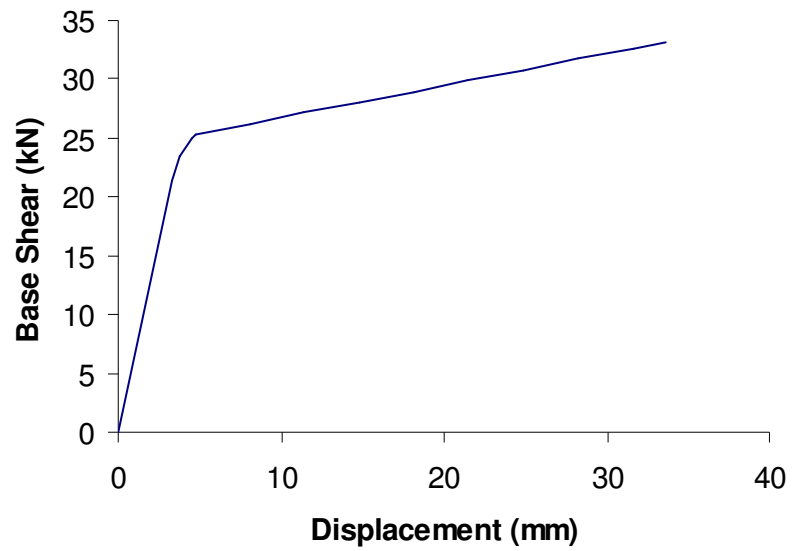

Figure 3.17. Base shear vs top displacement curve for one retrofitted frame in sap2000

Table 3.3. Base shear and top displacement values of bare frame

	Base Shear (kN)	Displacement (mm)
Test Specimen After Retrofit	35.0	36.0
Computer Model After Retrofit	33.17	33.6

### 3.4. Drift Check According to SAP 2000 Results

Table 3.4. Performance limit calculation

	H column (mm)	Top Displacement $\Delta$ (mm)	Drift % $\Delta/H$	Performance Limit
Before Retrofit	1800	54.0	0.0300	CP
After Retrofit	1800	33.6	0.019	LS

Difference between retrofitted test specimen and retrofitted computer model is % 5.23 in base shear and, % 6.67 in top displacement. Difference was % 2.00 and % 3.57 respectively before applying retrofit.

So that it can be said that model of plates not exactly represents the behavior of them when the results compared.

## 4. BUILDING EXAMPLE

In order to realize how we can retrofit a moderately damaged building by means of steel plate shear walls one example from Turkey / Zeytinburnu is chosen to retrofit and evaluate its performance.



Figure 4.1. Position of selected building

#### 4.1. Seismic Evaluation of an Existing Building with Increasing Equivalent Earthquake Load Method

Table 4.1. General characteristics of the building

##### **Building Information:**

Number of Story	5
Story Height	2.75m
Total Building Height	13.75m
Building Settlement Area	62.34 m <sup>2</sup>
Using Purpose	Residential

##### **Material Properties:**

Concrete	C16 $f_{ck}=16$ MPa
Steel	S220 $f_{yk}=220$ MPa
Concrete Elasticity Modulus [ $E_c$ ]	27000 MPa
Steel Elasticity Modulus [ $E_s$ ]	200000 MPa

##### **Project Parameters:**

Earthquake Region	1
Effective Ground Acceleration [ $A_0$ ]	0.4
Building Importance Factor [I]	1
Soil Type	Z3
Spectrum Characteristic Periods	$T_A=0.15s$ , $T_B=0.60s$
Live Load Participation Factor	$n=0.3$

##### **Loads:**

Concrete Density	25.00 kN/ m <sup>3</sup>
Wall Load	2.50 kN/ m <sup>2</sup>
Live Load	5.00 kN/ m <sup>2</sup>
Superimposed Dead Load	1.50 kN/ m <sup>2</sup>

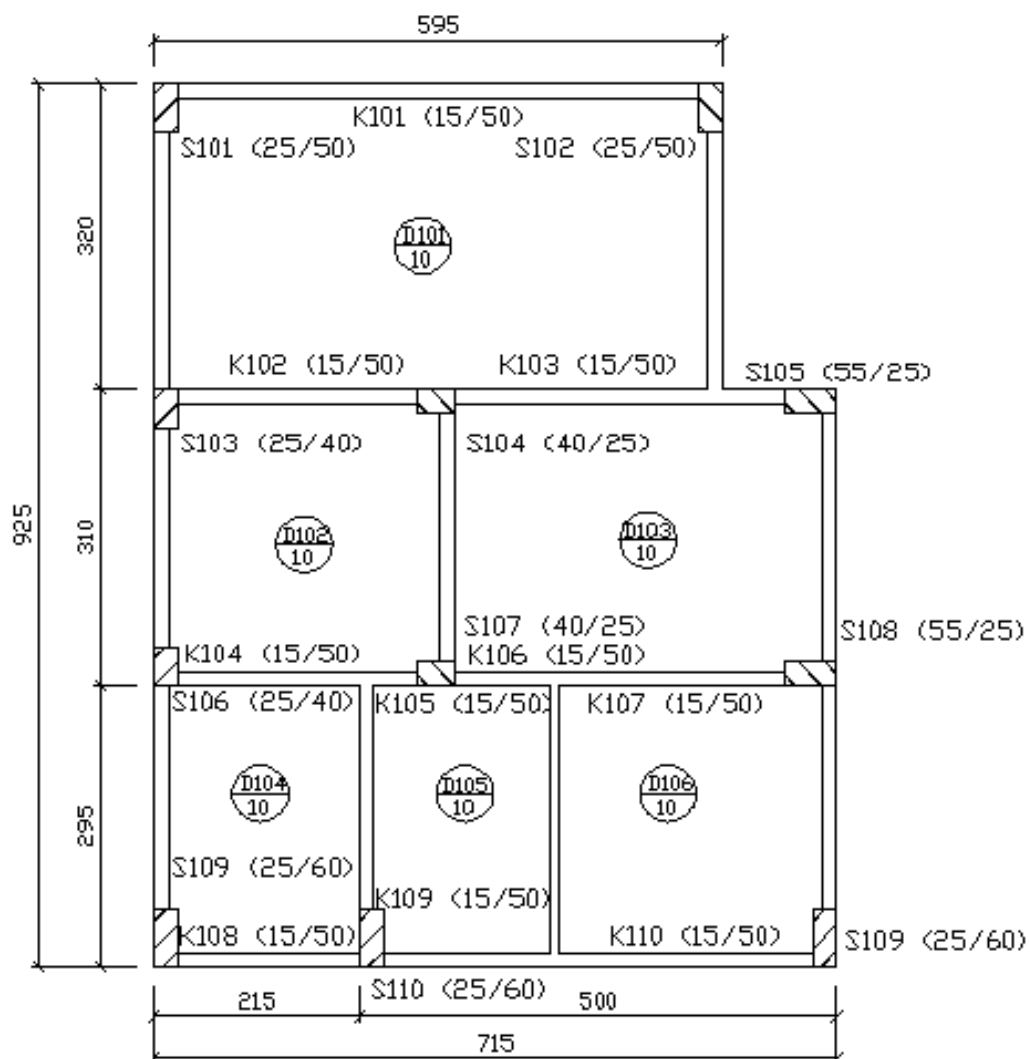

Figure 4.2. Floor plan

## 4.2. Bending Rigidities for Cracked Sections

According to The Turkish Seismic Code (TSC,2007) 7.6.4.6 for concrete members, subjected to the bending effect for elastic behavior before yielding, using cracked section bending rigidities is necessary.

- $A_c$ : section area,  
 $b$ : width of the section,  
 $EI_0$ : bending rigidity,  
 $f_{ck}$ : characteristic compressive strength,  
 $h$ : height of the section,  
 $N_d$ : axial force,  
 $h$ : height of the section,

For beams sample calculation;

$$h=50 \text{ cm } b=15 \text{ cm}$$

$$E_c=20000 \text{ MPa, } I_0=1.6 \text{ E-03 m}^4$$

$$0.4 EI_0=0.4 \times 20000000 \times 1.6 \text{ E-03} =12800 \text{ kNm}^2 \quad (4.1)$$

For columns sample calculation,

$$N_d/(A_c f_{ck}) \leq 0.10 \Rightarrow 0.40 EI_0 \quad (4.2)$$

$$N_d/(A_c f_{ck}) \leq 0.10 \Rightarrow 0.80 EI_0 \quad (4.3)$$

$$h=40 \text{ cm } b=25 \text{ cm}$$

$$f_{ck}= 16 \text{ MPa}$$

$$N_d= 98 \text{ kN}$$

$$A_c \times f_{ck}= 1600 \text{ kN}$$

$$N_d/(A_c f_{ck})=0.06$$

$$E_c = 20000 \text{ MPa, } I_0 = 5.2 \text{ E-03 m}^4$$

$$0.4 EI_0 = 0.4 \times 20000000 \times 5.2 \text{ E-03} = 41600 \text{ kNm}^2 \quad (4.4)$$

### 4.3. Describing Section Materials

Material properties are modeled in Xtract computer program and described to the SAP 2000.

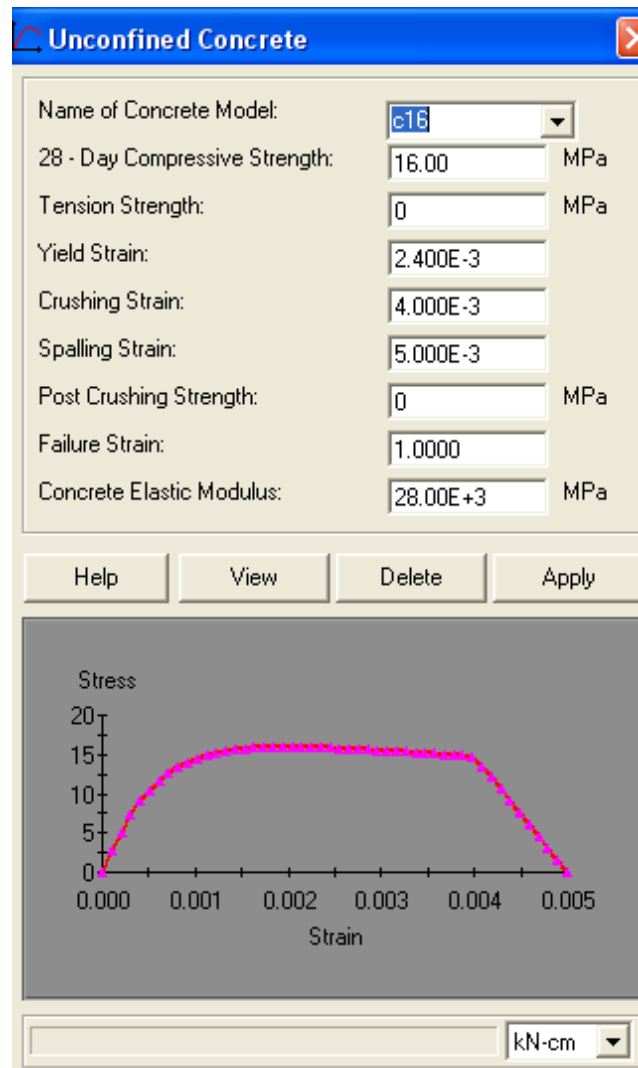

Figure 4.3. Unconfined concrete model

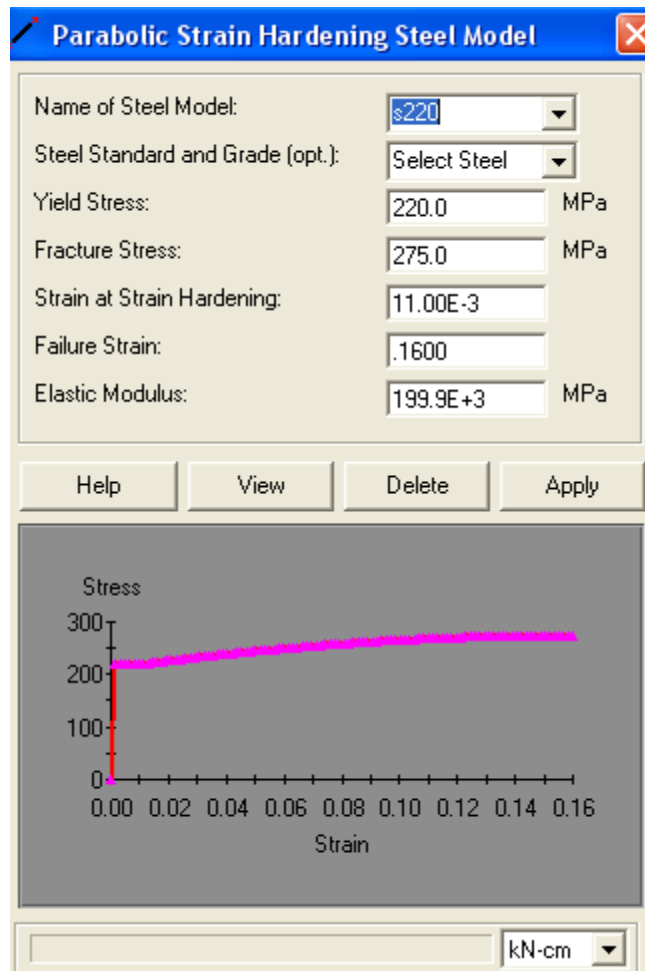

Figure 4.4. Steel model

#### 4.4. Describing Plastic Sections for Columns

According to The Turkish seismic code (2007) 7.6.4.5 interaction diagrams for columns will develop as being 3 dimensional. In order to satisfy this criterion interaction diagrams for  $0^\circ$ ,  $45^\circ$  and  $180^\circ$  were obtained by using Xtract computer program.

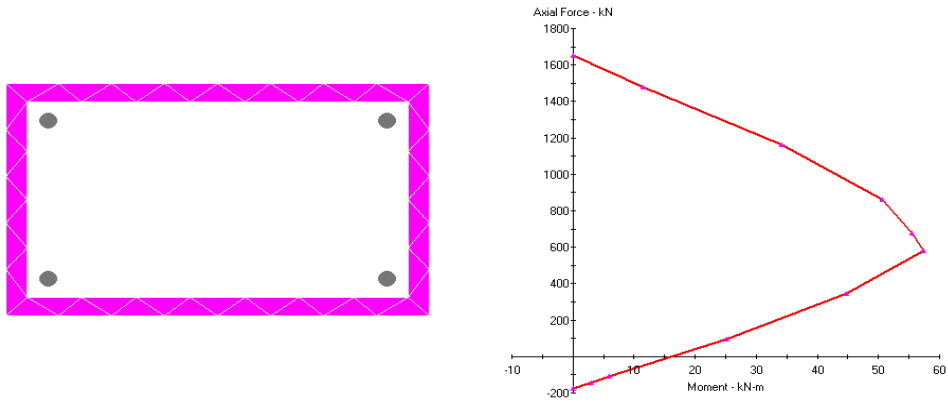

Figure 4.5. 40x25 column p-m relationship for 0°

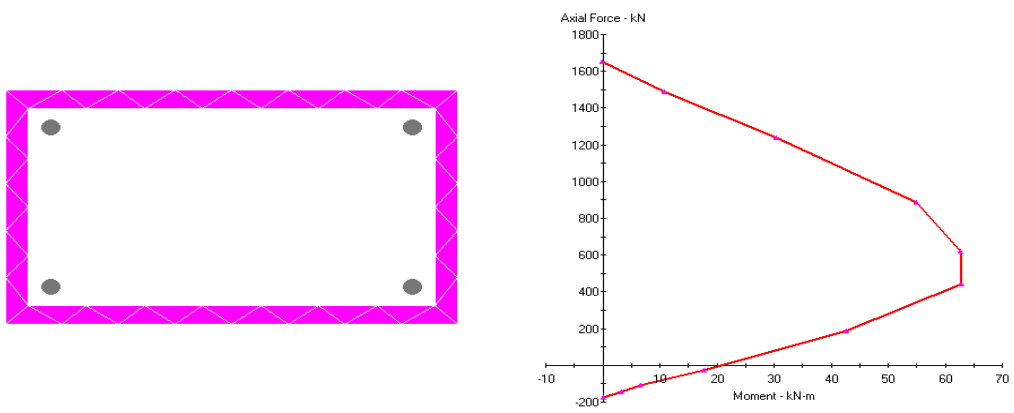

Figure 4.6. 40x25 column p-m relationship for 45°

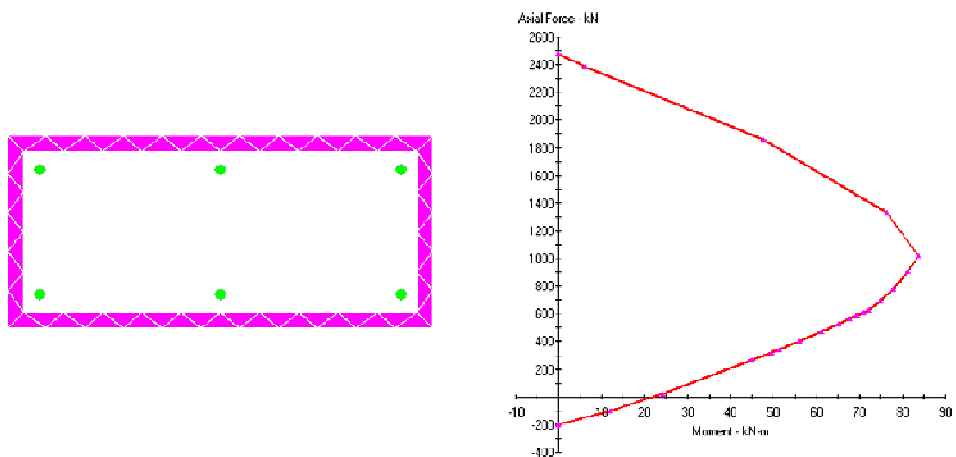

Figure 4.7. 55x25 column p-m relationship for 0°

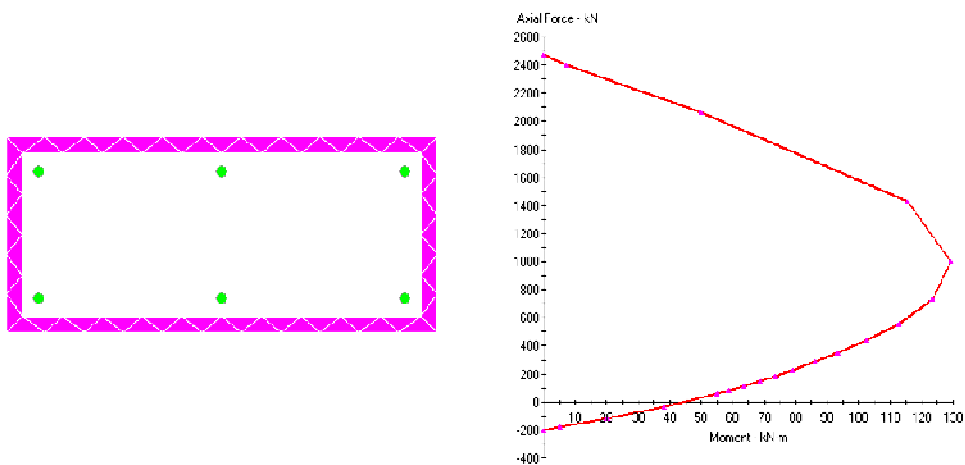

Figure 4.8. 55x25 column p-m relationship for 45°

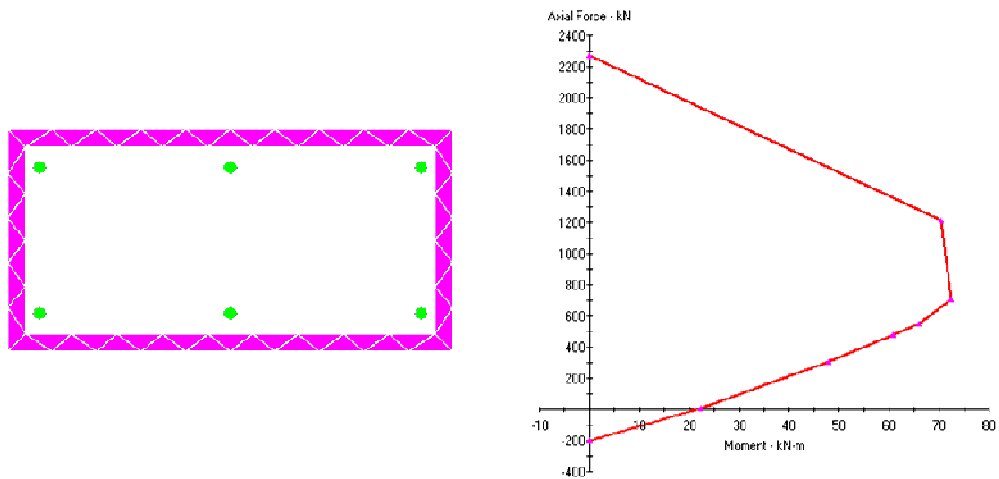

Figure 4.9. 50x25 column p-m relationship for 0°

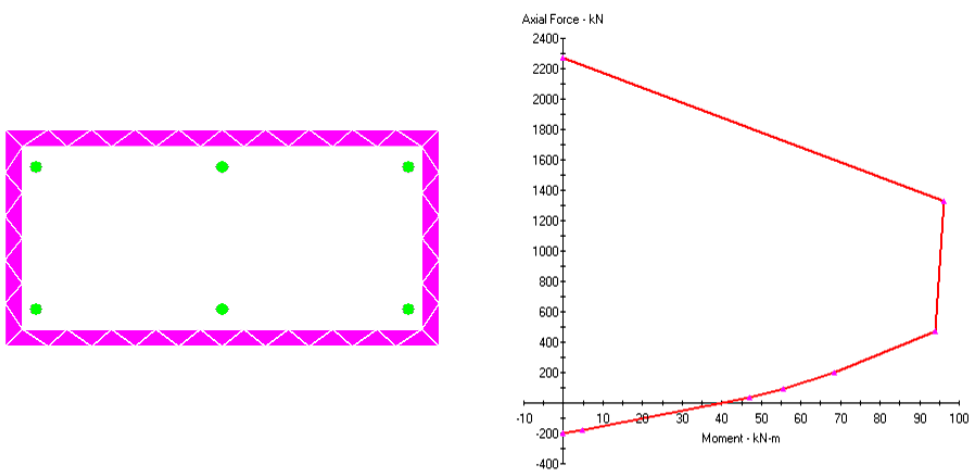

Figure 4.10. 50x25 column p-m relationship for 45°

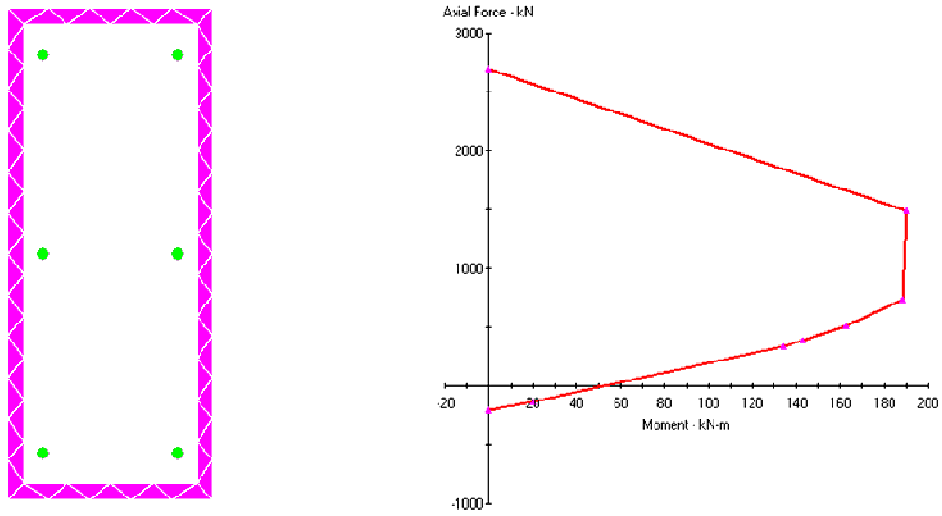

Figure 4.11. 25x60 column p-m relationship for  $0^\circ$

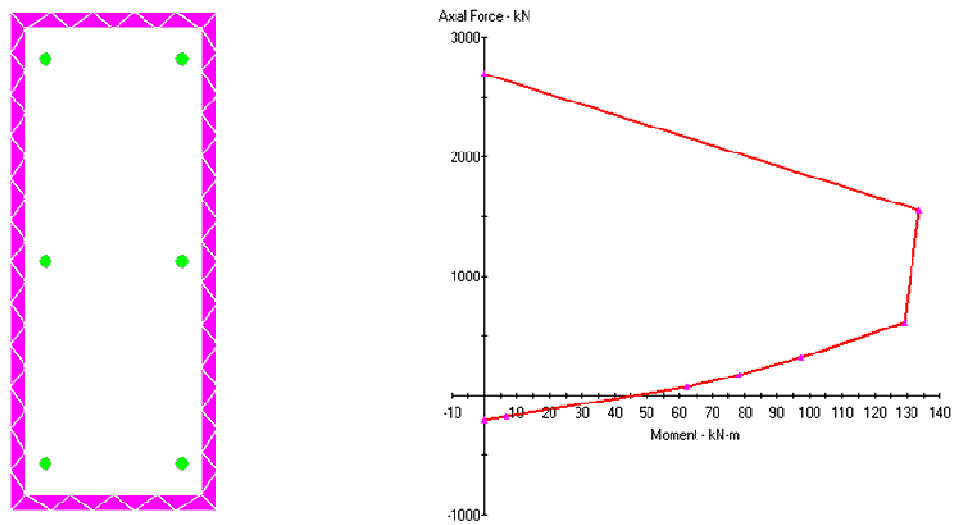

Figure 4.12. 25x60 column p-m relationship for  $45^\circ$

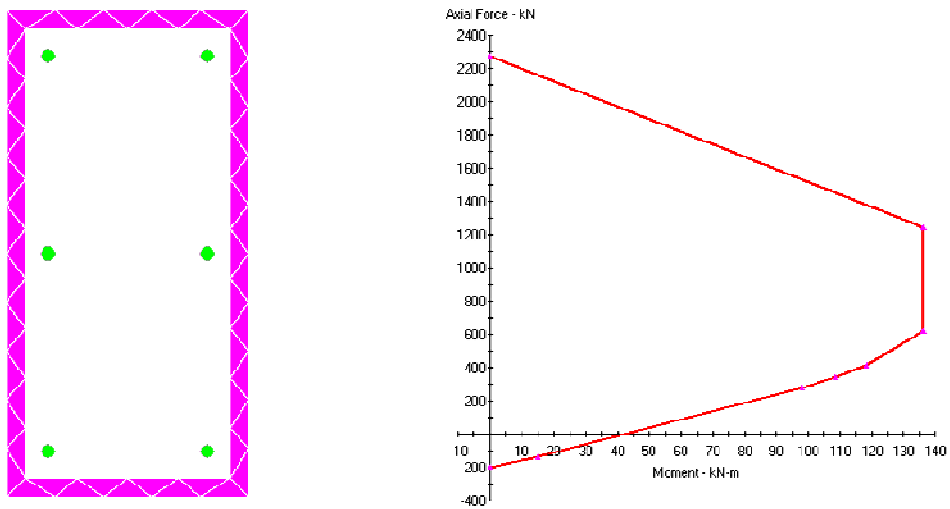

Figure 4.13. 25x50 column p-m relationship for  $0^\circ$

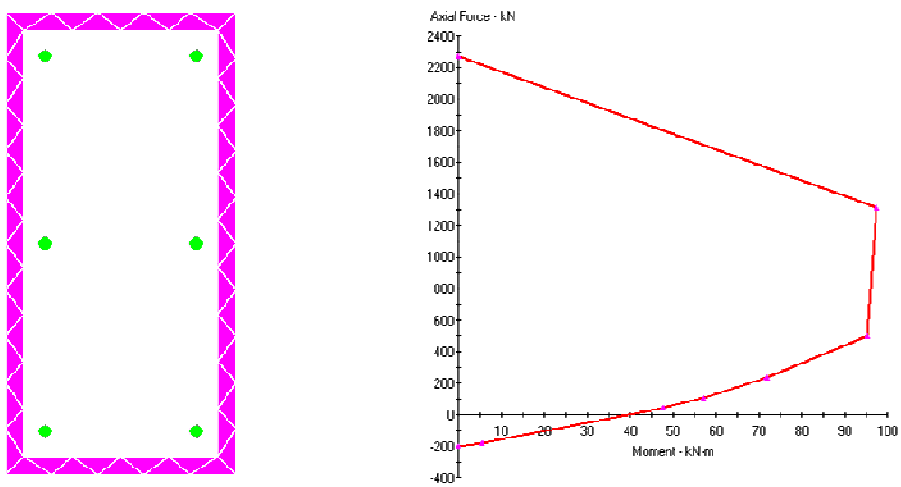

Figure 4.14. 25x50 column p-m relationship for  $45^\circ$

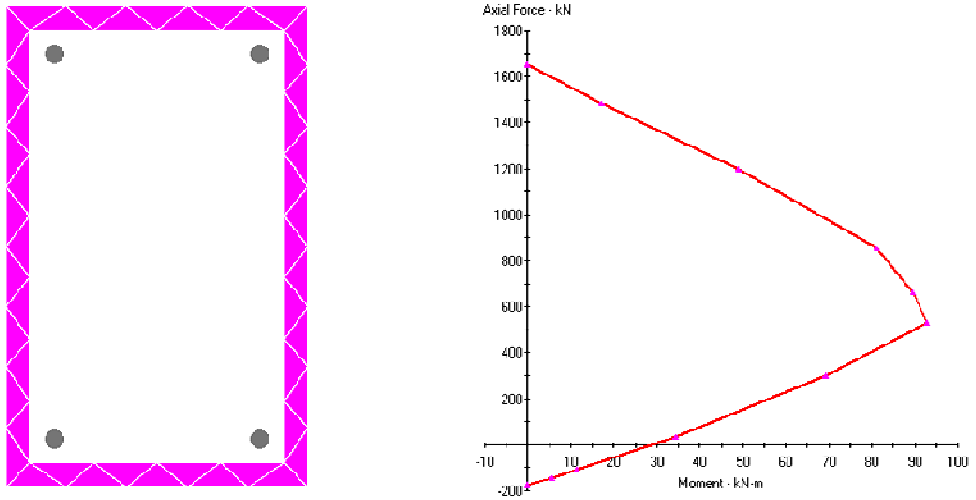

Figure 4.15. 25x40 column p-m relationship for  $0^\circ$

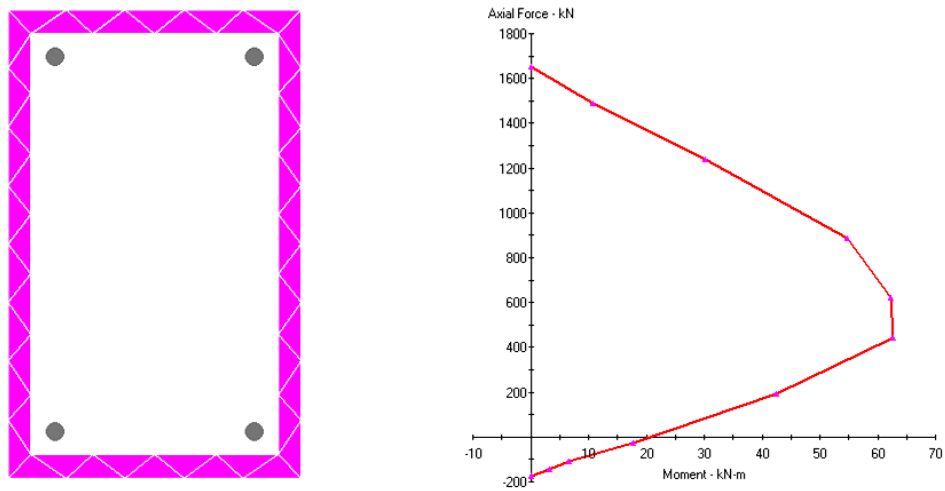

Figure 4.16. 25x40 column p-m relationship for  $45^\circ$

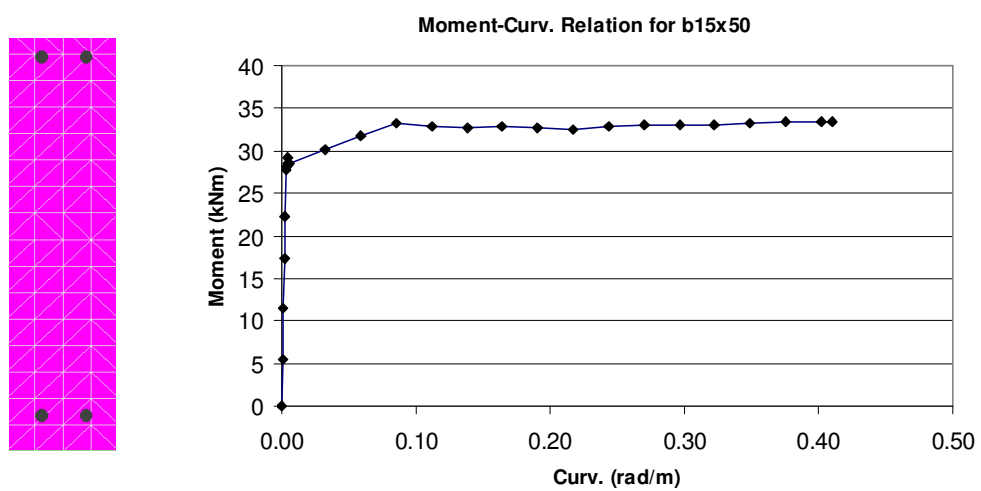

Figure 4.17. 15x50 beam section moment curvature relationship

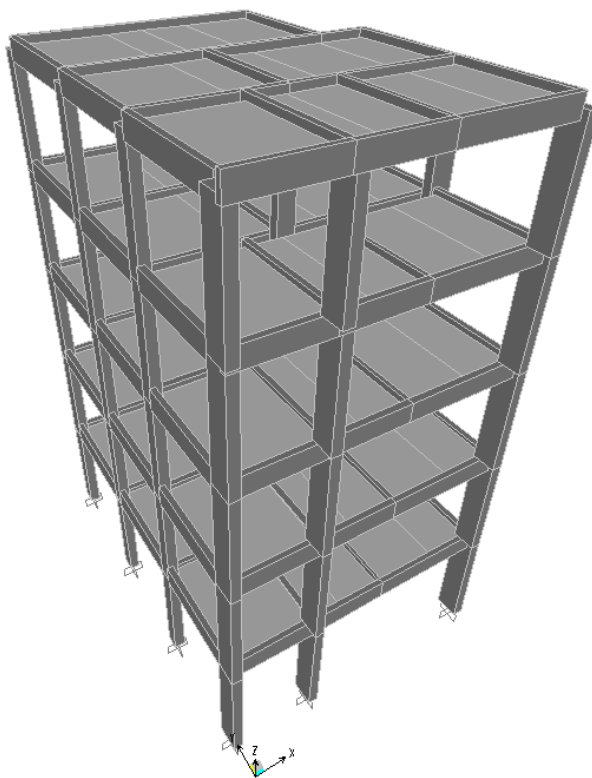

Figure 4.18. Sap 2000 3-d model

#### 4.5. Nonlinear Pushover Analysis under Sustained Loads

According to the Turkish seismic code (2007) 7.6.3(b) before the pushover analysis, a nonlinear static analysis case took into account which is compatible with the masses.

$$\text{Vertical Load Combination: } G+nQ = G+0.3Q \quad (4.5)$$

#### 4.6. Performing Criteria of Increasing Equivalent Seismic Load Method

According to the Turkish seismic code (2007) 7.6.5.2 to accomplish this analysis it is necessary that:

Total number of stories is required to be below 8

It is satisfied: Number of stories is 5

Torsional irregularity factor  $\eta_{bi}$  should be smaller than 1.4

It is satisfied due to the symmetrical plan of the building for both orthogonal axes.

In the earthquake direction that we considered, participated mass ratio should be greater than 0.7 for linear elastic behavior.

Table 4.2. Participated mass ratios belongs to the first natural period in x direction

Mode	Period (s)	Participated Mass		Check	
		X Direction	Y Direction		
1	0.54	0.83	0	>	0.7
2	0.52	0	0.74	>	0.7

For both direction participated mass ratio is greater than 0.7, so that increasing equivalent seismic load method is applicable.

#### 4.7. Obtaining Pushover Curve

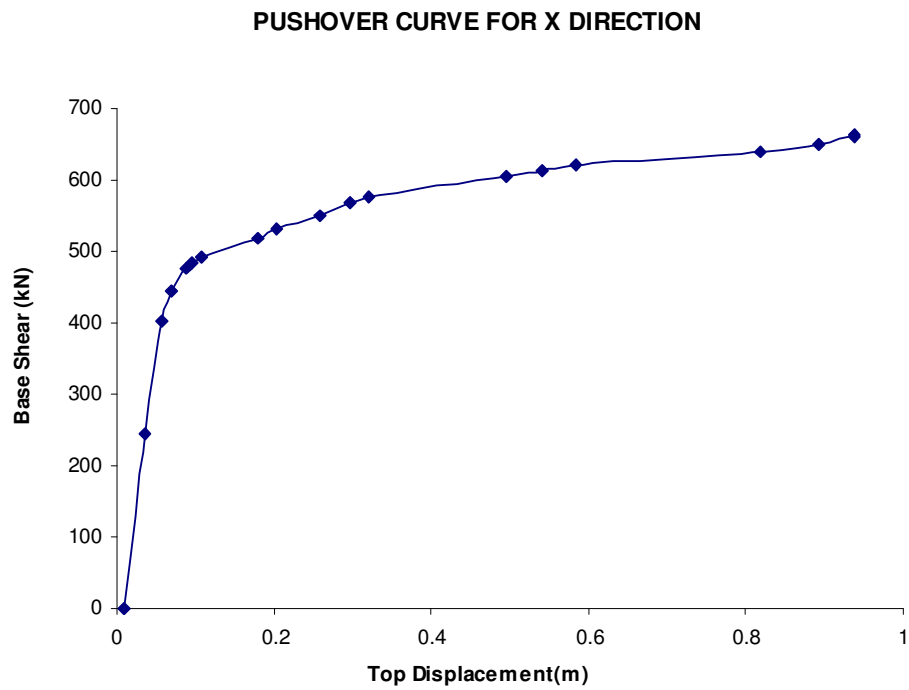

Figure 4.19. Pushover Curve for x direction

#### 4.8. Obtaining Modal Capacity Diagram and Capacity Curve

Pushover curve for x direction is changed to modal capacity diagram by means of using these formulas mentioned below.

Modal acceleration  $a_1^{(i)}$  (belongs to the first mode) at (i)th push step is calculated with the formula below;

$$a_1^{(i)} = \frac{V_{x1}^{(i)}}{M_{x1}} \quad (4.6)$$

Modal displacement  $d_1(i)$  (belongs to the first mode) at (i)th push step is calculated with the formula below;

$$d_1^{(i)} = \frac{u_{xN1}^{(i)}}{\Phi_{xN1} \Gamma_{x1}} \quad (4.7)$$

Table 4.3. Calculation of capacity diagram coordinates

$u_{xN1}^{(i)}$ (m)	$V_{x1}^{(i)}$ (kN)	$M_{x1}$	$\Phi_{xN1}$	$\Gamma_{x1}$	$d_1^{(i)}$ (m)	$a_1^{(i)}$ (m/s <sup>2</sup> )
0.00	0.00	212.00	0.088	13.09	0.00	0.00
0.03	243.97	212.00	0.088	13.09	0.03	1.15
0.04	402.03	212.00	0.088	13.09	0.04	1.90
0.06	444.63	212.00	0.088	13.09	0.05	2.10
0.07	477.22	212.00	0.088	13.09	0.06	2.25
0.09	485.37	212.00	0.088	13.09	0.08	2.29
0.10	493.31	212.00	0.088	13.09	0.09	2.33
0.11	517.43	212.00	0.088	13.09	0.09	2.44
0.18	530.86	212.00	0.088	13.09	0.16	2.51
0.20	549.88	212.00	0.088	13.09	0.17	2.59
0.26	568.81	212.00	0.088	13.09	0.23	2.68
0.30	575.93	212.00	0.088	13.09	0.26	2.72
0.32	604.30	212.00	0.088	13.09	0.28	2.85
0.50	648.09	212.00	0.088	13.09	0.43	3.06
0.54	673.07	212.00	0.088	13.09	0.50	3.17
0.58	735.10	212.00	0.088	13.09	0.71	3.47
0.82	744.70	212.00	0.088	13.09	0.77	3.51
0.89	751.53	212.00	0.088	13.09	0.82	3.54
0.94	751.53	212.00	0.088	13.09	0.82	3.54
0.94	752.31	212.00	0.088	13.09	0.82	3.54
0.94	752.32	212.00	0.088	13.09	0.82	3.54

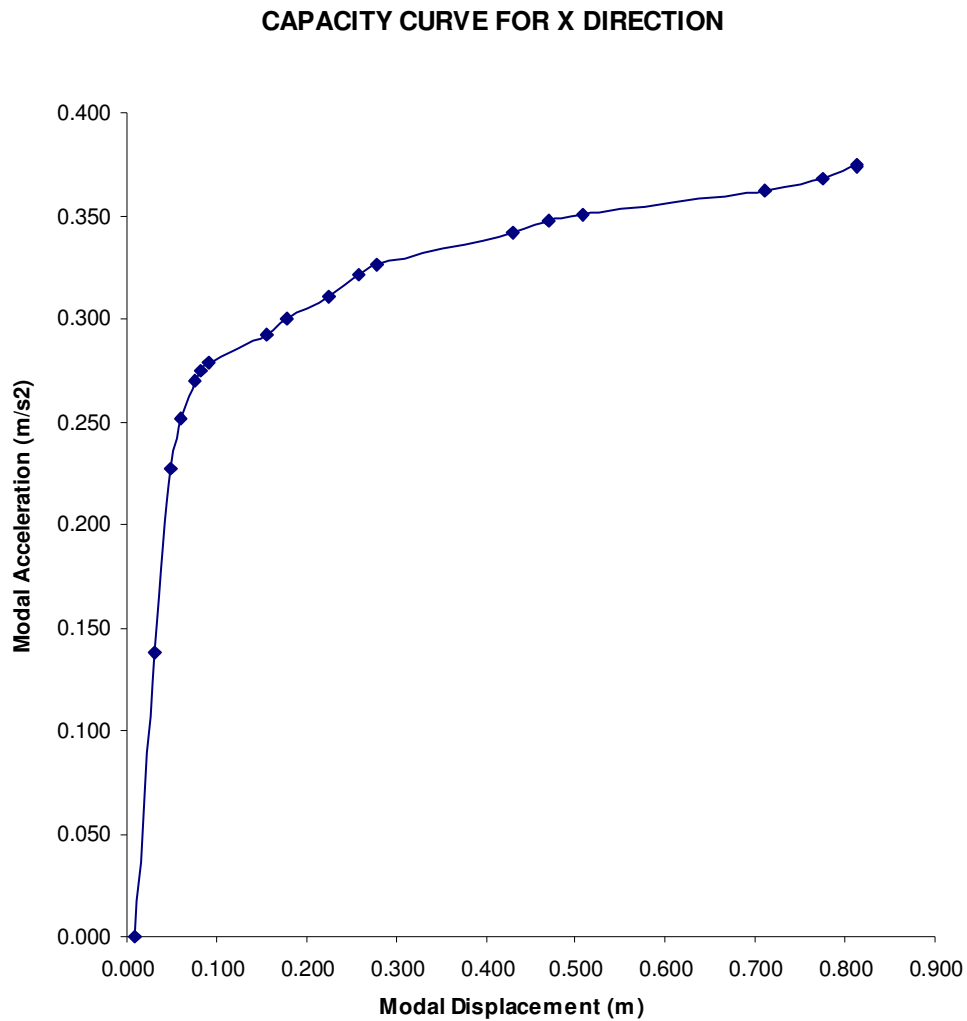

Figure 4.20. Capacity Curve for x direction

#### 4.9. Calculation of Demanded Displacement

Modal displacement demand is calculated by using formulas below.

Nonlinear spectral displacement ( $S_{di1}$ ) is obtained subjected to the linear spectral displacement ( $S_{de1}$ ) that has calculated as being base of first natural period.

$$S_{di1} = C_{R1} S_{de1} \quad (4.8)$$

Linear spectral displacement ( $S_{d1}$ ) is calculated from elastic spectral acceleration ( $S_{ae1}$ ) at the first step of the pushover analysis that belongs to the first mode.

$$S_{de1} = \frac{S_{ae1}}{(\omega_1^{(1)})^2} \quad (4.9)$$

### ADRS

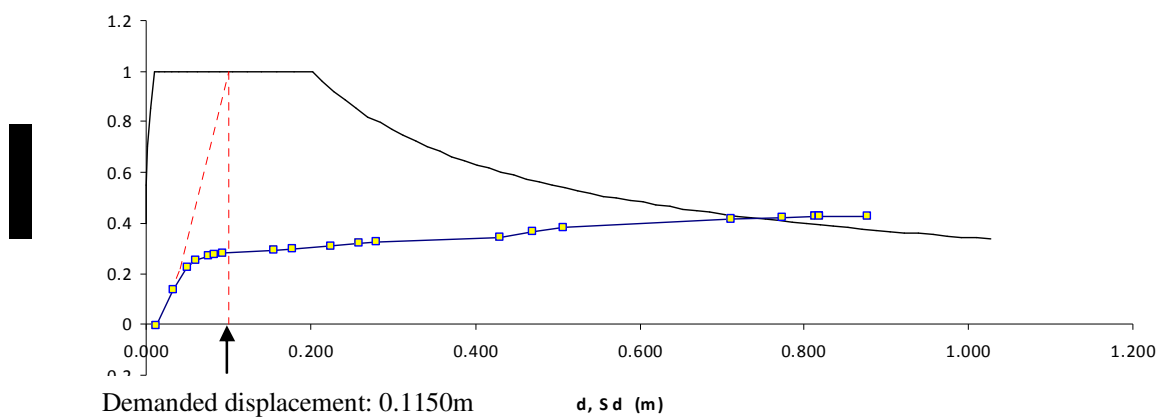

Figure 4.21. ADRS

Displacement that is demanded by the earthquake is calculated as being 11.50 cm, so that pushover analysis should be repeated up to this demanded displacement value.

#### 4.10. Second Pushover Analysis

Pushover analysis repeated in accordance with the displacement level demanded by earthquake.

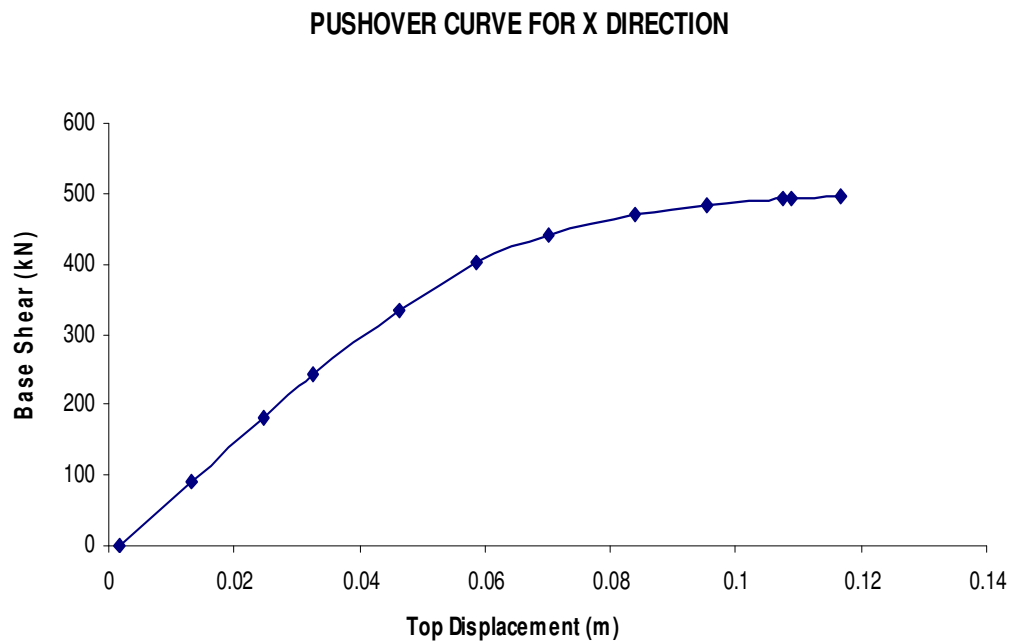

Figure 4.22. Pushover Curve for x direction

#### 4.11. Obtaining Modal Capacity Diagram

Pushover curve for x direction is changed to modal capacity diagram by means of using these formulas mentioned below.

Modal acceleration  $a_1^{(i)}$  (belongs to the first mode) at (i)th push step is calculated with the formula below;

$$a_1^{(i)} = \frac{V_{x1}^{(i)}}{M_{x1}} \quad (4.10)$$

Modal displacement  $d_1(i)$  (belongs to the first mode) at (i)th push step is calculated with the formula below;

$$d_1^{(i)} = \frac{u_{xN1}^{(i)}}{\Phi_{xN1} \Gamma_{x1}} \quad (4.11)$$

Table 4.4. Calculation of capacity diagram coordinates

$\mathbf{u}_{xN1}^{(i)}$ (m)	$\mathbf{V}_{x1}^{(i)}$ (kN)	$\mathbf{M}_{x1}$	$\mathbf{\Phi}_{xN1}$	$\mathbf{\Gamma}_{x1}$	$\mathbf{d}_1^{(i)}$ (m)	$\mathbf{a}_1^{(i)}$ (m/s <sup>2</sup> )
0.00	0.00	212.00	0.0880	13.09	0.00	0.00
0.01	91.26	212.00	0.0880	13.09	0.01	0.05
0.02	182.52	212.00	0.0880	13.09	0.02	0.11
0.03	243.97	212.00	0.0880	13.09	0.03	0.14
0.05	335.37	212.00	0.0880	13.09	0.04	0.19
0.06	402.03	212.00	0.0880	13.09	0.05	0.23
0.07	441.61	212.00	0.0880	13.09	0.06	0.26
0.08	469.21	212.00	0.0880	13.09	0.07	0.27
0.10	483.64	212.00	0.0880	13.09	0.08	0.28
0.11	492.12	212.00	0.0880	13.09	0.09	0.29
0.11	493.31	212.00	0.0880	13.09	0.09	0.29
0.12	496.71	212.00	0.0880	13.09	0.10	0.29

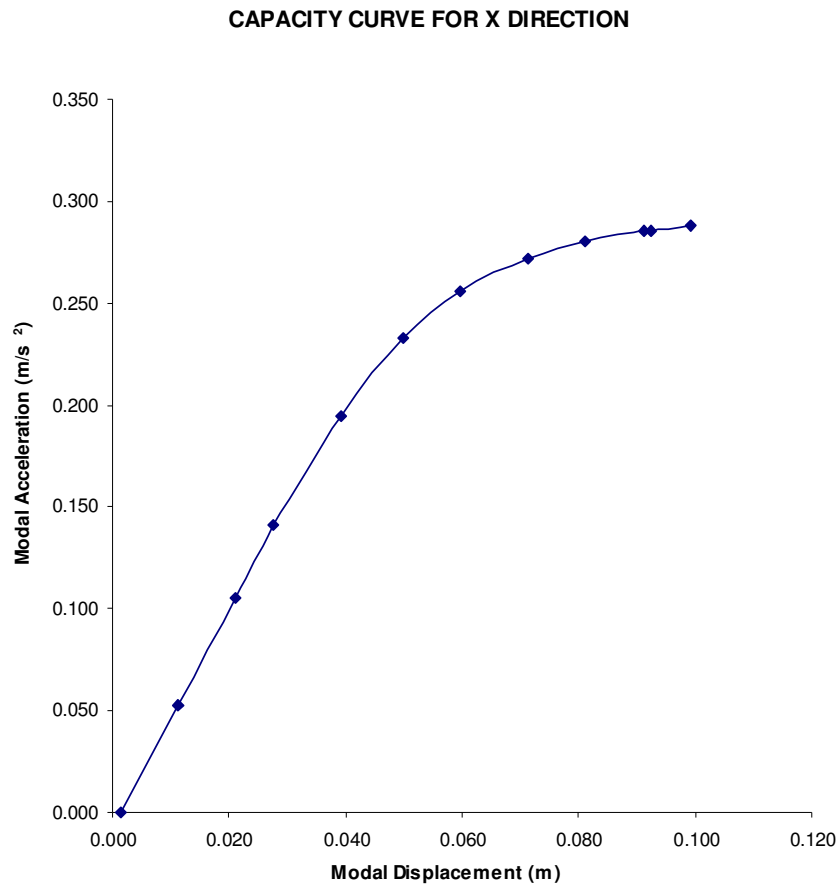

Figure 4.23. Capacity Curve for x direction

#### 4.12. Calculation of Spectral Displacement

Period of the system  $T_1 = 0.54 \text{ s} < T_B$  so that spectral displacement ratio (CR1) can not be assumed as equal to 1.

When it comes to strength reduction factor ( $R_y$ ), this value might be calculated as mentioned in Turkish seismic code (2007) with equal areas rule figured below;

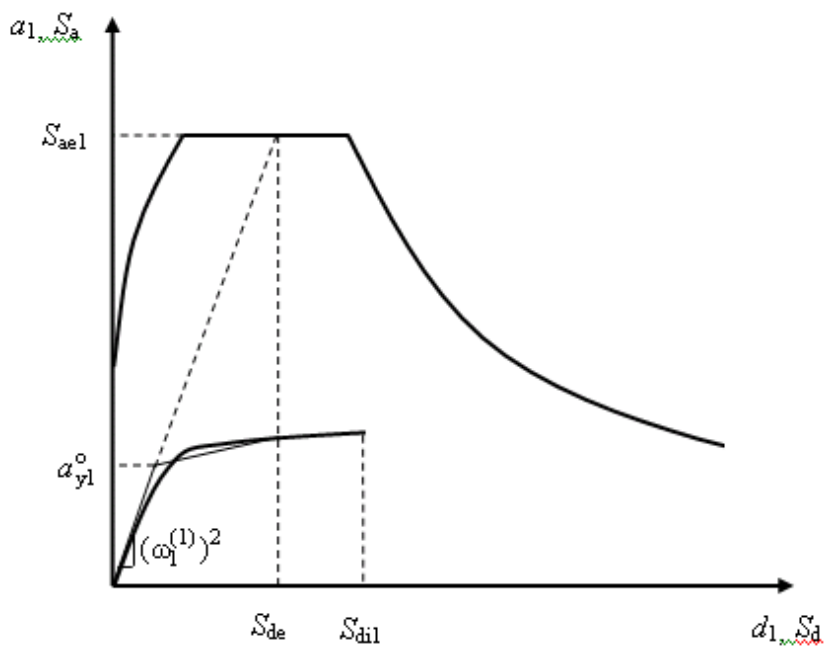

Figure 4.24. Equal Areas Rule

**ADRS**

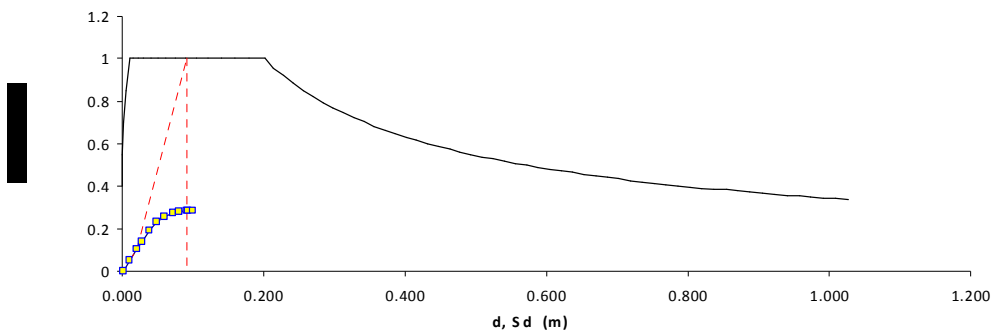

Figure 4.25. ADRS

Table 4.5. Calculation of nonlinear spectral displacement

$T_1$	$T_B$	$S_{de1}$	$R_y$	$C_{r1}$	$S_{di1}$
		$\frac{S_{ae1}}{(\omega_1^{(1)})^2}$	$\frac{S_{ae1}}{a_{y1}}$	$\frac{1 + (R_{y1} - 1)T_B / T_1^1}{R_{y1}}$	$C_{r1} * S_{de1}$
(s)	(s)	(cm)			(cm)
0.54	0.60	10.74	2.63	1.12	12.00

At the time when top displacement demand is satisfied plastic hinges figured below for x direction.

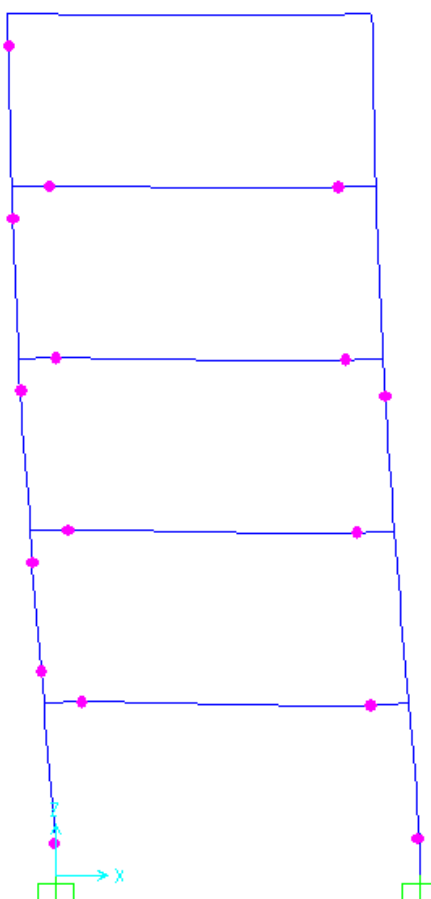

Figure 4.26. 4-4 Axis Plastic Hinges.

### 4.13. Determining Performance Level of the Building

By using strain capacities mentioned in the Turkish seismic code (2007) axial force vs. curvature diagrams are obtained by using xtract computer program.

Table 4.6. Strain limits

Damage Limit	Strain Limits		
	Unconfined Concrete	Unconfined Concrete	Steel
Minimum Damage	0.004		0.010
Life Safety		$0.004+0.0095(\rho_s/\rho_{sm})$	0.040
Collapse Prevention		$0.004+0.0013(\rho_s/\rho_{sm})$	0.060

In order to calculate yield curvature, M.J.N. PRIESTLY Formula is used.

- Circular column  $\Phi_y = 2.25 \epsilon_y/D$
- Rectangular column  $\Phi_y = 2.10 \epsilon_y/hc$
- Rectangular cantilever walls  $\Phi_y = 2.00 \epsilon_y/Iw$
- T-Section Beams  $\Phi_y = 1.70 \epsilon_y/hb$

#### 4.14. Total Curvature Calculation

Table 4.7. Example of total curvature calculation

Frame Section	Axial Force	Plastic Rotation	Plastic Hinge Length	Plastic Curvature	Yield Curvature	Total Curvature
	P (kN)	$\theta$ (rad)	Lp (m)	$\Phi_p$ (rad/m) $\Phi_p = \theta / Lp$	$\Phi_y$ (rad/m)	$\Phi_t$ (rad/m) $\Phi_t = \Phi_p + \Phi_y$
C40X25	224.523	0.077	0.200	0.383	0.006	0.389
C40X25	175.273	0.068	0.200	0.340	0.006	0.346
C40X25	216.444	0.058	0.200	0.290	0.006	0.296
C40X25	161.893	0.071	0.200	0.274	0.006	0.363
C40X25	271.965	0.061	0.200	0.236	0.006	0.313
C40X25	117.804	0.048	0.200	0.186	0.006	0.248
C40X25	107.857	0.062	0.200	0.157	0.006	0.318
C40X25	272.281	0.062	0.200	0.156	0.006	0.316
C40X25	111.093	0.056	0.200	0.140	0.006	0.285
C40X25	182.521	0.053	0.200	0.132	0.006	0.269
C40X25	123.312	0.052	0.200	0.131	0.006	0.267
C40X25	122.127	0.050	0.200	0.126	0.006	0.257

For columns performance evaluation is done by using P-M interaction diagrams, and for beams it was done by using moment-curvature relationship.

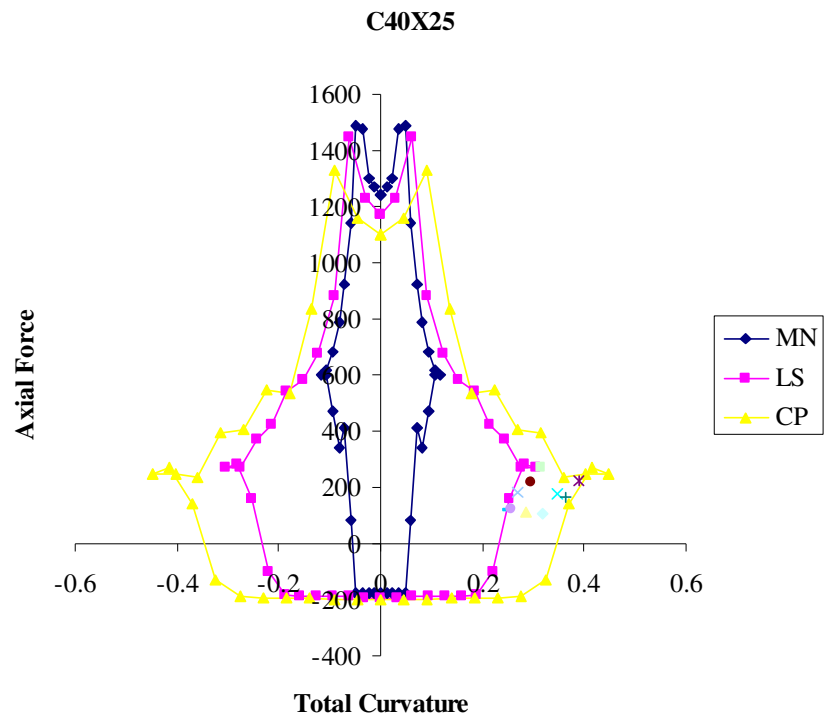

Figure 4.27. Performance assessment of C40x25 section

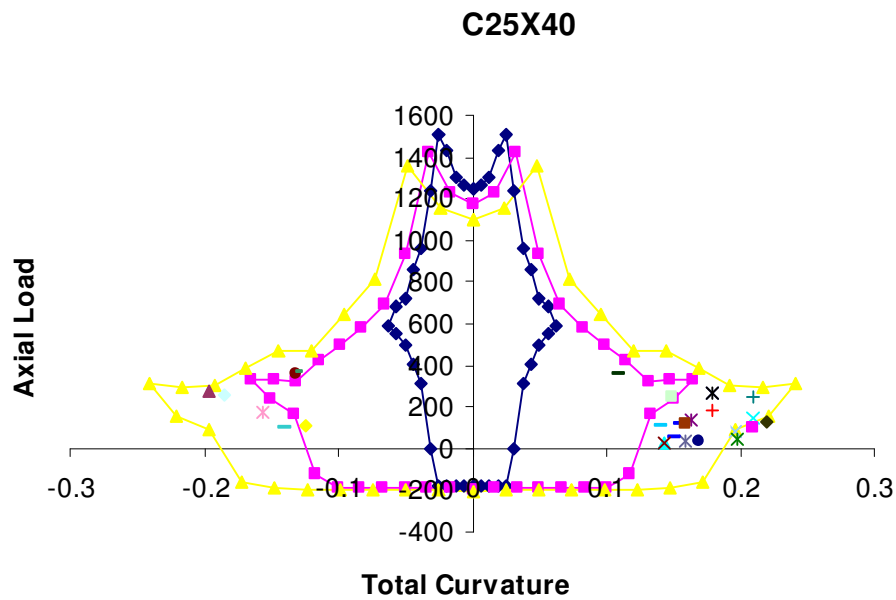

Figure 4.28. Performance assessment of C25x40 section

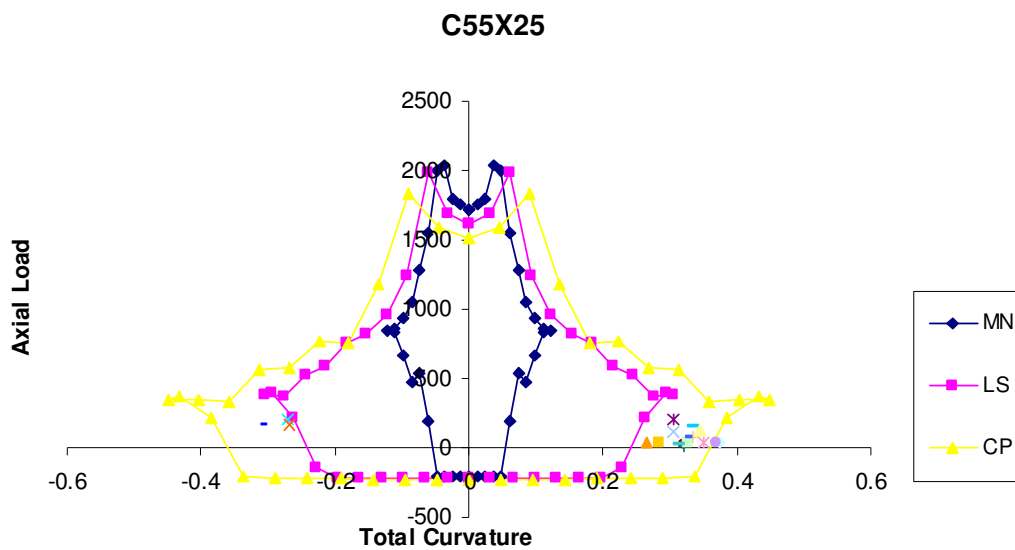

Figure 4.29. Performance assessment of C55x25 section

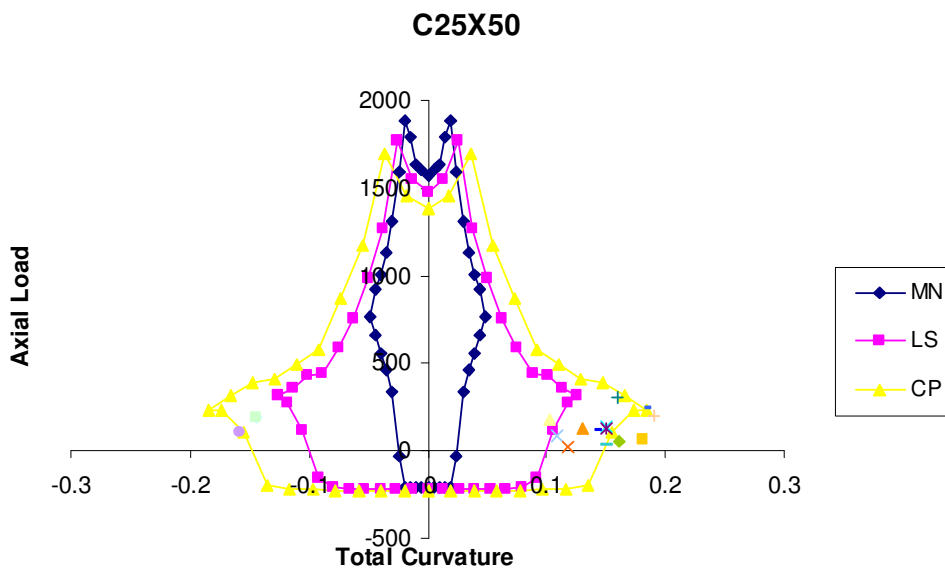

Figure 4.30. Performance assessment of C25x50 section

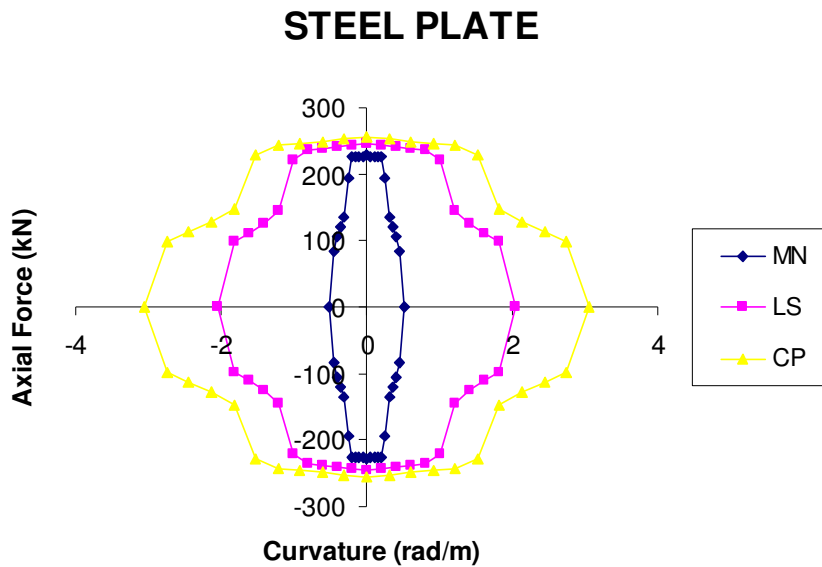

Figure 4.31. Performance assessment of panel section

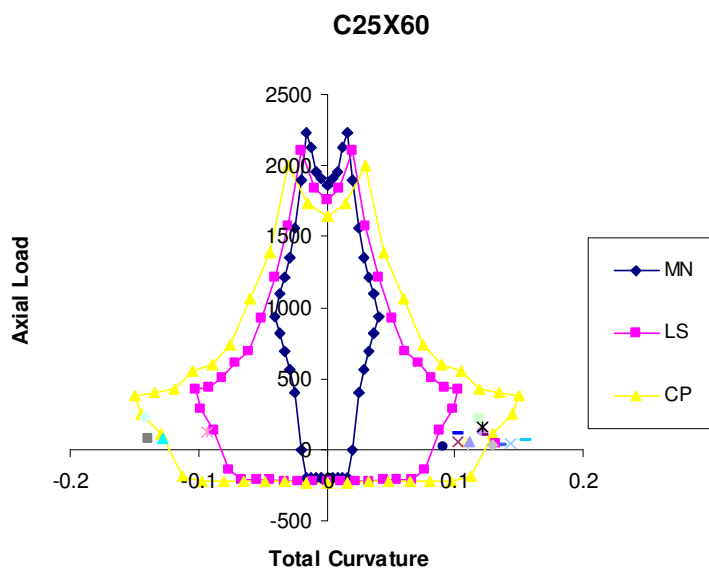

Figure 4.32. Performance assessment of C25x60 section

#### 4.15. Assessment of Performance Level

Whole structure took into account this system is between “*Life Safety*” and “*Collapse Prevention*” damage level. This region is called “*Advanced Damage Zone*” in Turkish seismic code (2007) like shown below;

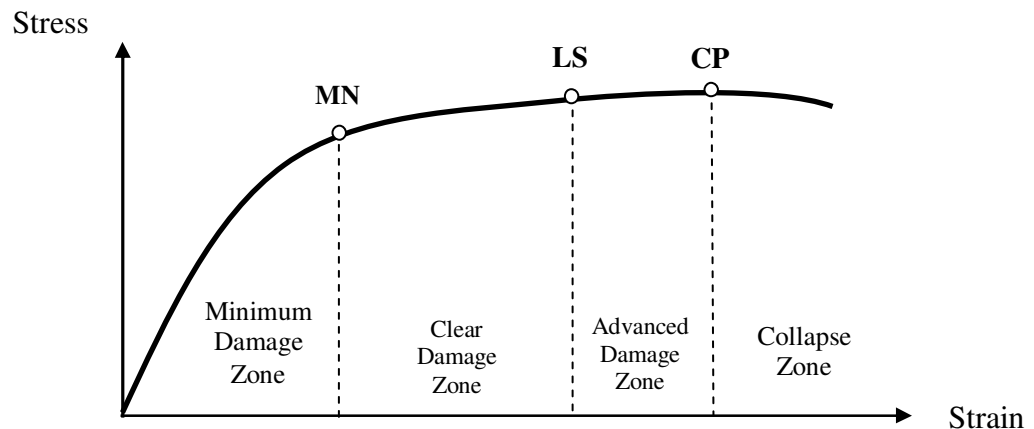

Figure 4.33. Damage zone assessment in Turkish seismic code

#### 4.16. Seismic Evaluation Retrofitted Building with Increasing Equivalent Earthquake Load Method

The analyzed building in previous section will be strengthened in this section by means of steel panels that figured below. Sap 2000 computer program is used to define steel panels. These panels are located like shown in the plan below, just in assumed earthquake direction x. Seismic performance assessment is also applied in x direction. Panels assumed to be fixed rigidity as being in columns. Neither section properties nor material properties of the existing building have changed in the model. Analysis results are evaluated in the following parts.

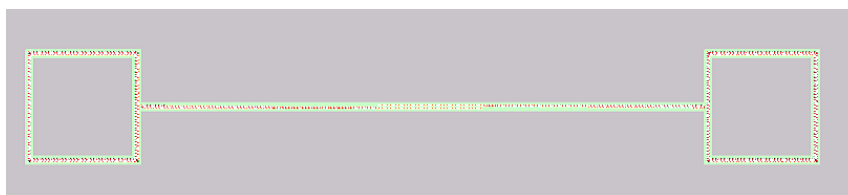

Figure 4.34. Steel Panel

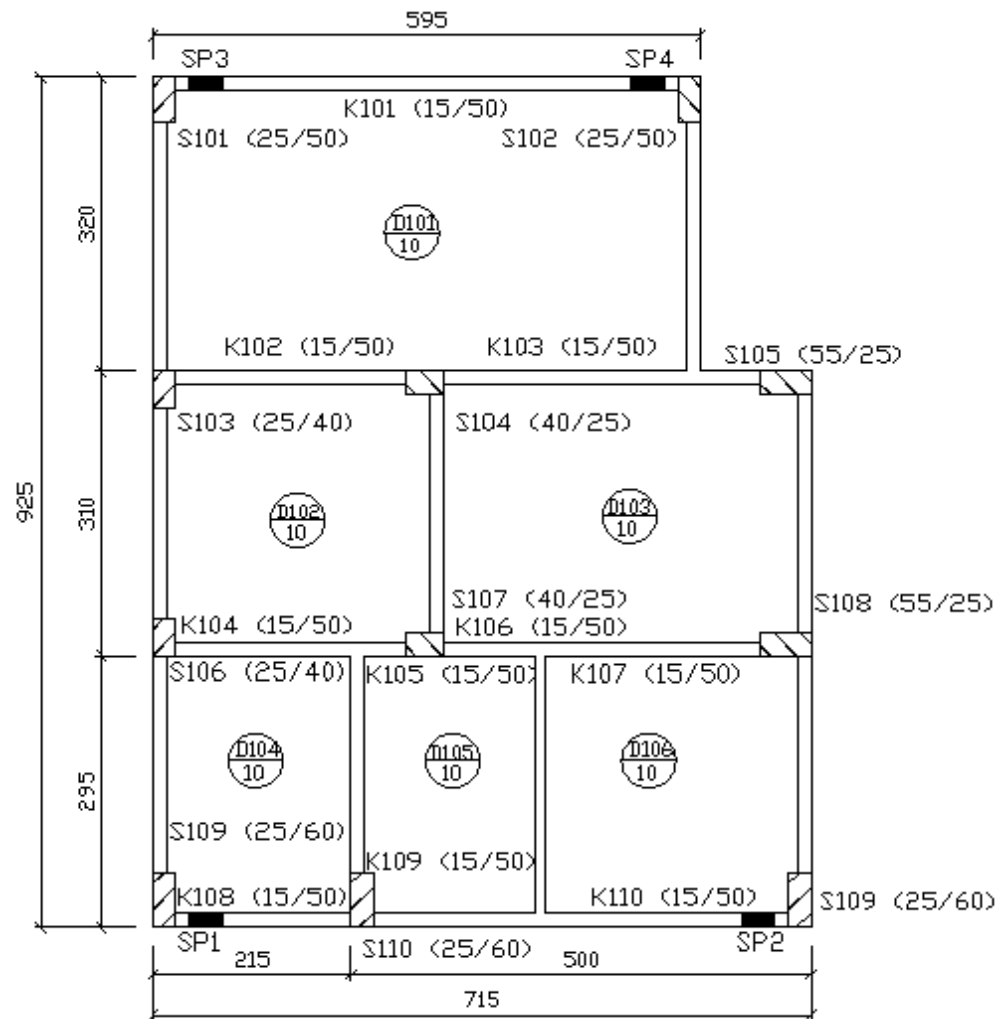

Figure 4.35. Floor plan with panels

#### 4.17. Describing Plastic Sections for Steel Plates

According to the Turkish seismic code (2007) 7.6.4.5 interaction diagrams for steel plates will be developed as being 3 dimensional. In order to satisfy this criteria, interaction diagrams were composed for  $0^\circ$ ,  $45^\circ$ , and  $180^\circ$  in xtract computer program as shown below;

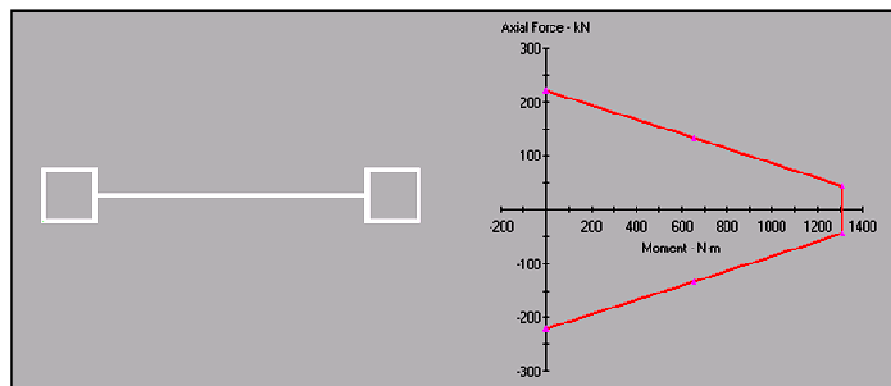

Figure 4.36. P-M relationship for panels

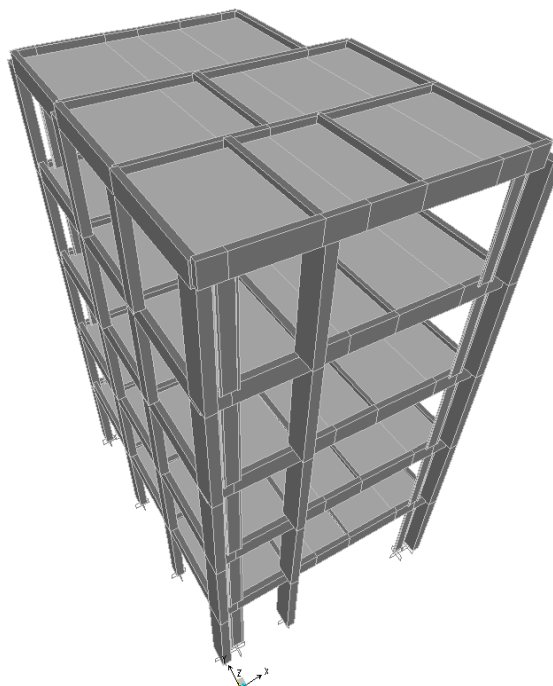

Figure 4.37. Sap 2000 3-d model for strengthened building

#### 4.18. Nonlinear Pushover Analysis under Sustained Loads

According to the Turkish seismic code (2007) 7.6.3(b) before the pushover analysis, a nonlinear static analysis case took into account which is compatible with the masses.

#### 4.19. Performing Criteria of Increasing Equivalent Seismic Load Method

According to the Turkish seismic code (2007) 7.6.5.2 to accomplish this analysis it is necessary that:

Total number of stories is required to be below 8

It is satisfied: Number of stories is 5

Torsional irregularity factor  $\eta_{bi}$  should be smaller than 1.4

It is satisfied due to the symmetrical plan of the building for both orthogonal axes.

In the earthquake direction that we considered, participated mass ratio should be greater than 0.7 for linear elastic behavior.

Table 4.8. Participated mass ratios belongs to the first natural period in x direction

Mode	Period (s)	Participated Mass		Check	
		X Direction	Y Direction		
1	0.43	0.74	0	>	0.7
2	0.41	0	0.71	>	0.7

For both direction participated mass ratio is greater than 0.7, so that it is possible to perform increasing equivalent seismic load method.

#### 4.20. Pushover Analysis

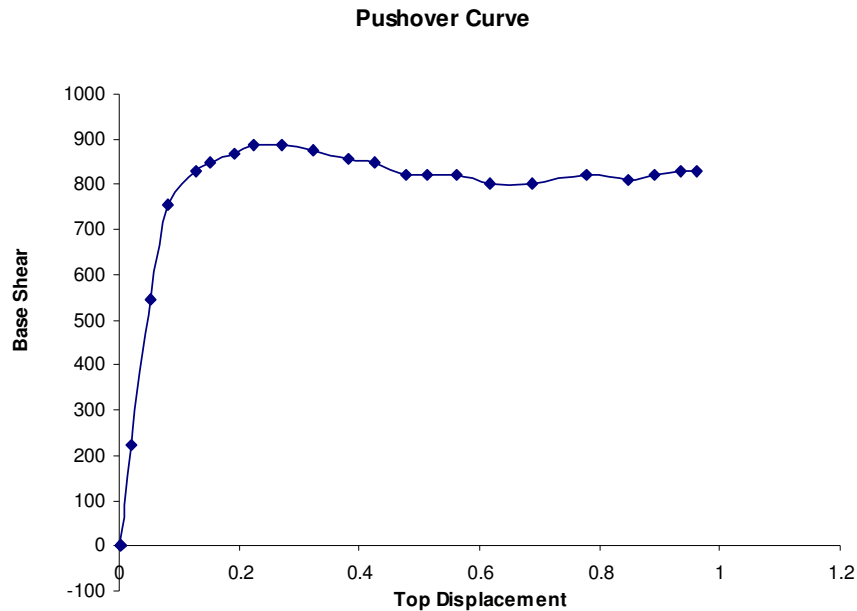

Figure 4.38. Pushover Curve for x direction

#### 4.21. Obtaining Modal Capacity Diagram

Table 4.9. Calculation of capacity diagram coordinates

$\mathbf{u}_{xN1}^{(i)}$ (m)	$\mathbf{V}_{x1}^{(i)}$ (kN)	$\mathbf{M}_{x1}$	$\mathbf{\Phi}_{xN1}$	$\mathbf{\Gamma}_{x1}$	$\mathbf{d}_1^{(i)}$ (m)	$\mathbf{a}_1^{(i)}$ (m/s <sup>2</sup> )
0.00	0.00	245.00	0.007	13.09	0.001	0.000
0.00	3.14	245.00	0.007	13.09	0.001	0.002
0.02	220.00	245.00	0.007	13.09	0.016	0.125
0.08	756.00	245.00	0.007	13.09	0.072	0.428
0.13	830.00	245.00	0.007	13.09	0.112	0.470

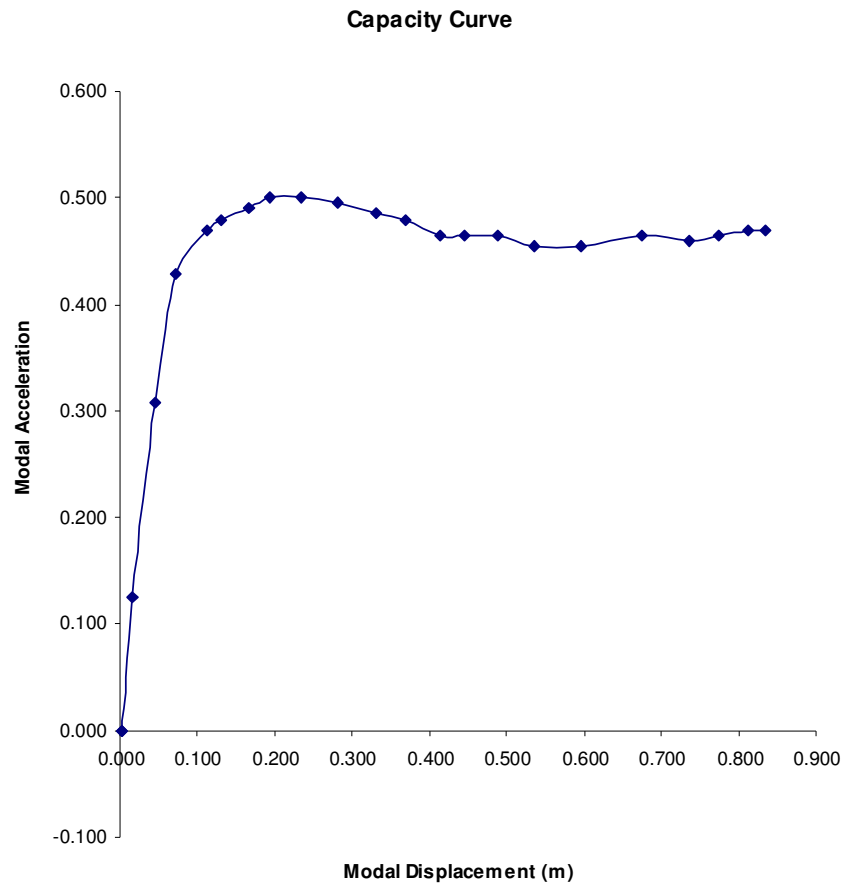

Figure 4.39. Capacity curve for x direction

#### 4.22. Calculation of Spectral Displacement

Period of the system  $T_1 = 0.43 \text{ s} < T_B$  so that spectral displacement ratio (CR1) can not be assumed as equal to 1.

When it comes to strength reduction factor ( $R_y$ ), this value might be calculated as mentioned in Turkish seismic code (2007) with equal areas rule figured below;

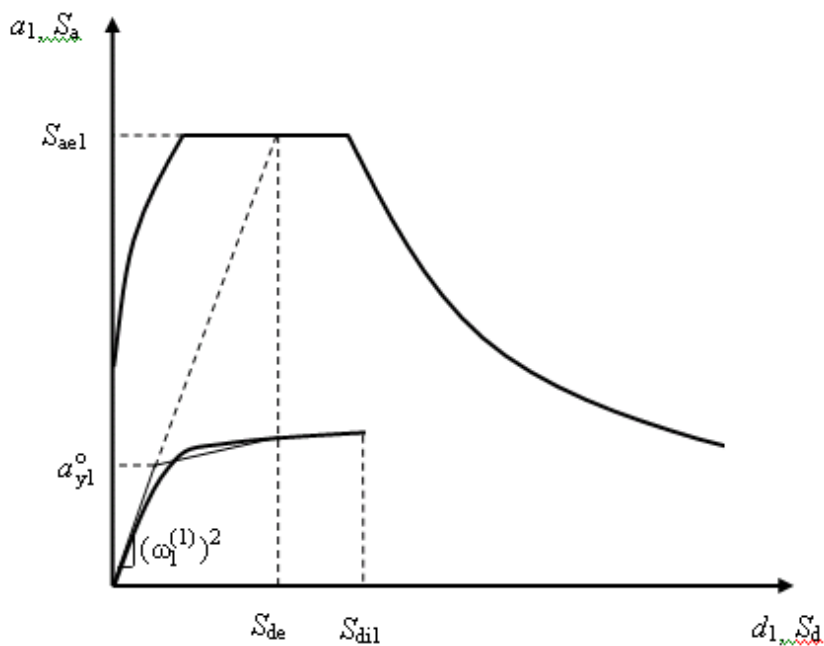

Figure 4.40. Equal areas rule

**ADRS**

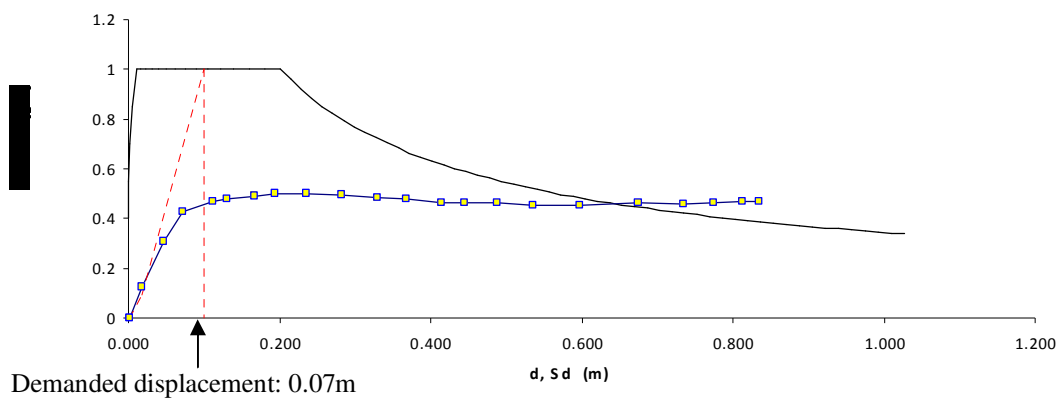

Figure 4.41. ADRS

Table 4.10. Calculation of nonlinear spectral displacement

$T_1$	$T_B$	$S_{de1}$ $\frac{S_{ae1}}{(\omega_1^{(1)})^2}$	$R_y$ $\frac{S_{ae1}}{a_{y1}}$	$C_{r1}$ $\frac{1 + (R_{y1} - 1)T_B / T_1^1}{R_{y1}}$	$S_{di1}$ $C_{r1} * S_{de1}$
(s)	(s)	(cm)			(cm)
0.43	0.60	6.4	1.3	1.09	6.98

At the time when top displacement demand is satisfied plastic hinges figured below for x direction.

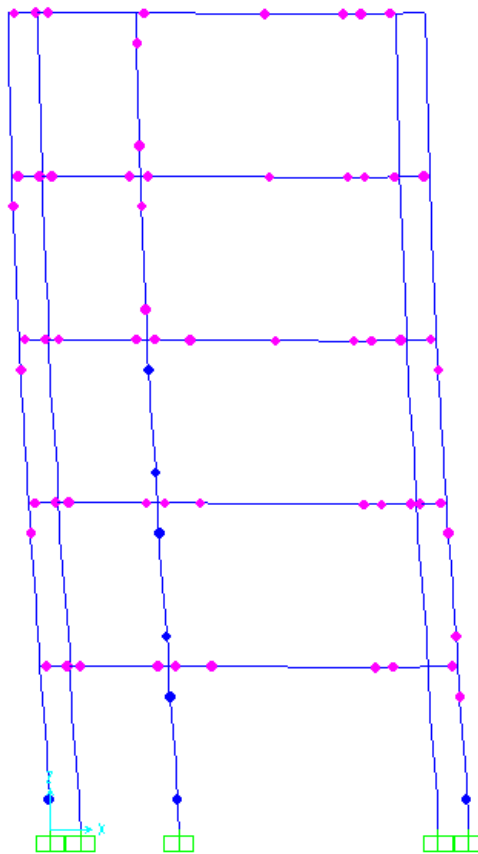

Figure 4.42. 4-4 axis plastic hinges

### 4.23. Determining Performance Level of the Building

Table 4.11. Example of total curvature calculation

Frame Section	Axial Force	Plastic Rotation	Plastic Hinge Length	Plastic Curvature	Yield Curvature	Total Curvature
	P (kN)	$\theta$ (rad)	$L_p$ (m)	$\Phi_p$ (rad/m) $\Phi_p = \theta/L_p$	$\Phi_y$ (rad/m)	$\Phi_t$ (rad/m) $\Phi_t = \Phi_p + \Phi_y$
C40X25	261.866	0.0058	0.200	0.029	0.006	0.035
C40X25	256.358	0.0060	0.200	0.030	0.006	0.036
C40X25	296.859	0.0186	0.200	0.093	0.006	0.099
C40X25	291.352	0.0058	0.200	0.029	0.006	0.035
C40X25	211.224	0.0058	0.200	0.029	0.006	0.035
C40X25	205.717	0.0122	0.200	0.061	0.006	0.067
C40X25	236.209	0.0076	0.200	0.038	0.006	0.044
C40X25	230.702	0.0074	0.200	0.037	0.006	0.043
C40X25	159.694	0.0092	0.200	0.046	0.006	0.052
C40X25	154.186	0.0088	0.200	0.044	0.006	0.050
C40X25	174.039	0.0080	0.200	0.040	0.006	0.046
C40X25	168.531	0.0084	0.200	0.042	0.006	0.048

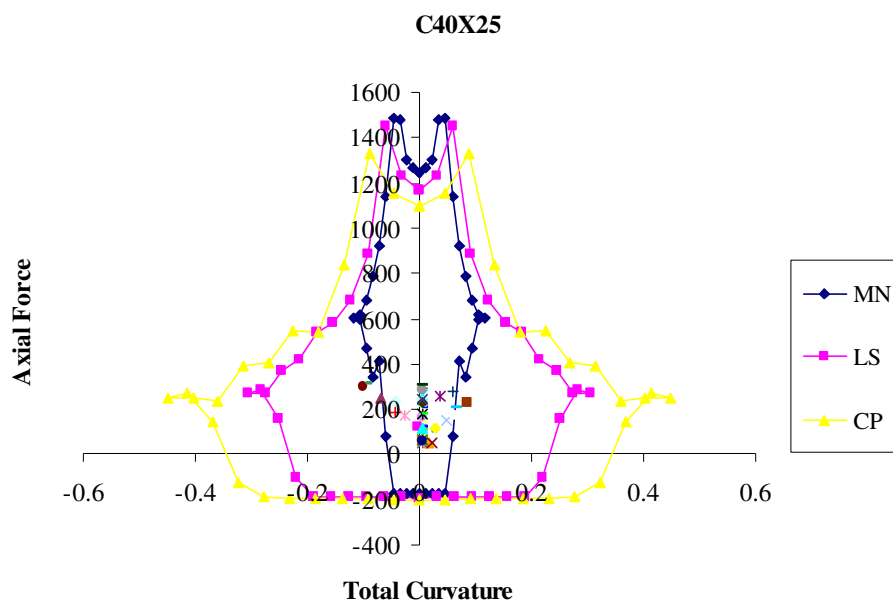

Figure 4.43. Performance assessment of C40x25 section

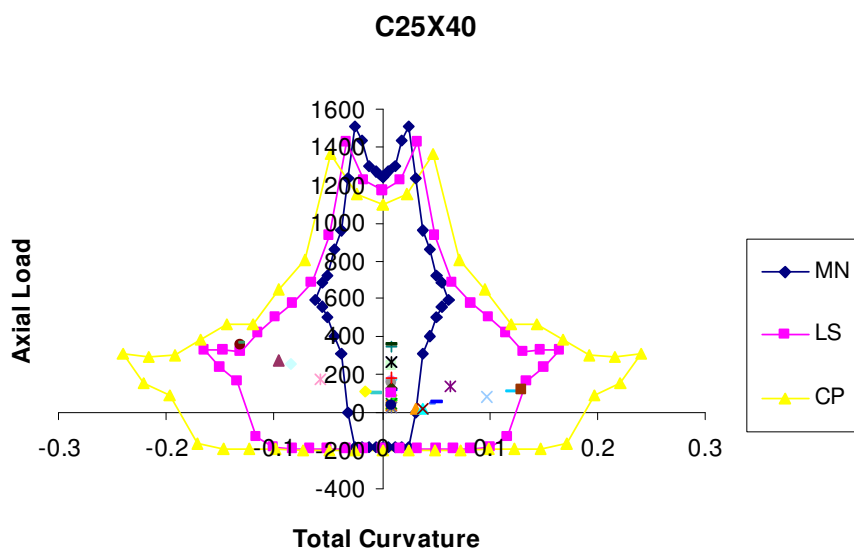

Figure 4.44. Performance assessment of C25x40 section

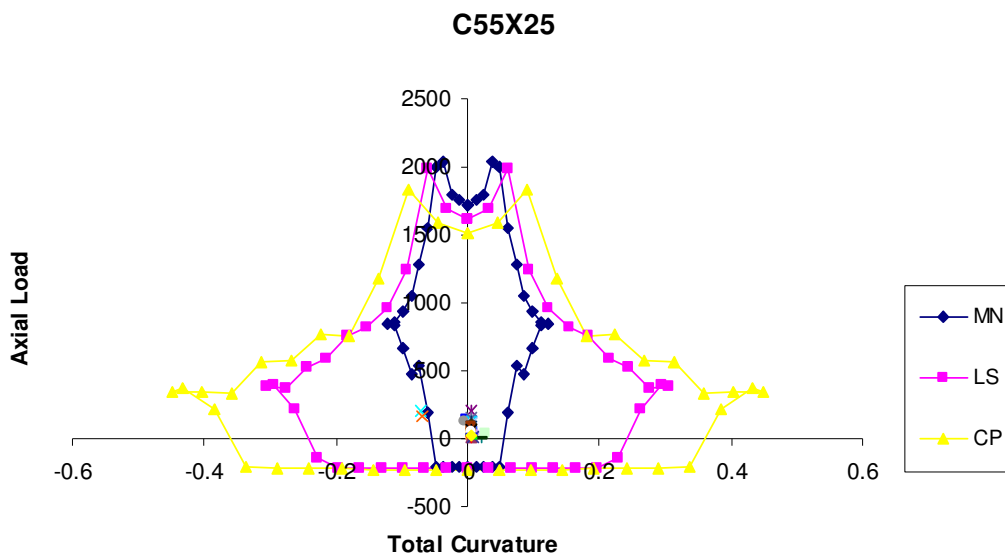

Figure 4.45. Performance assessment of C55x25 section

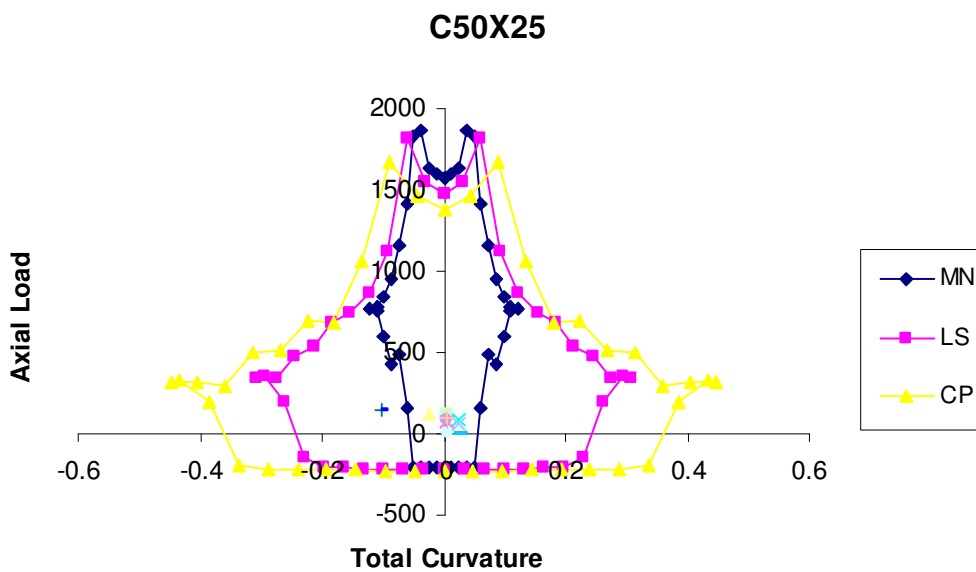

Figure 4.46. Performance assessment of C50x25 section

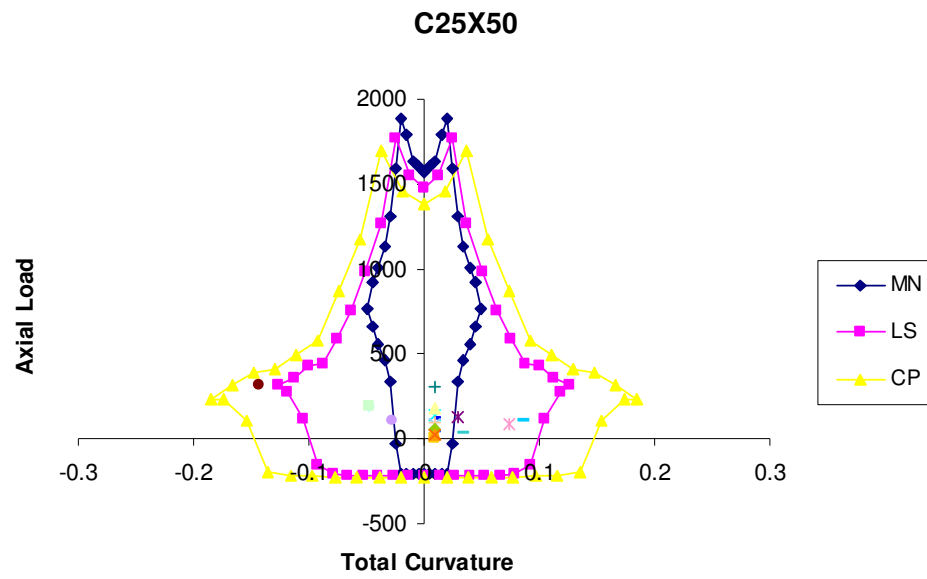

Figure 4.47. Performance assessment of C25x50 section

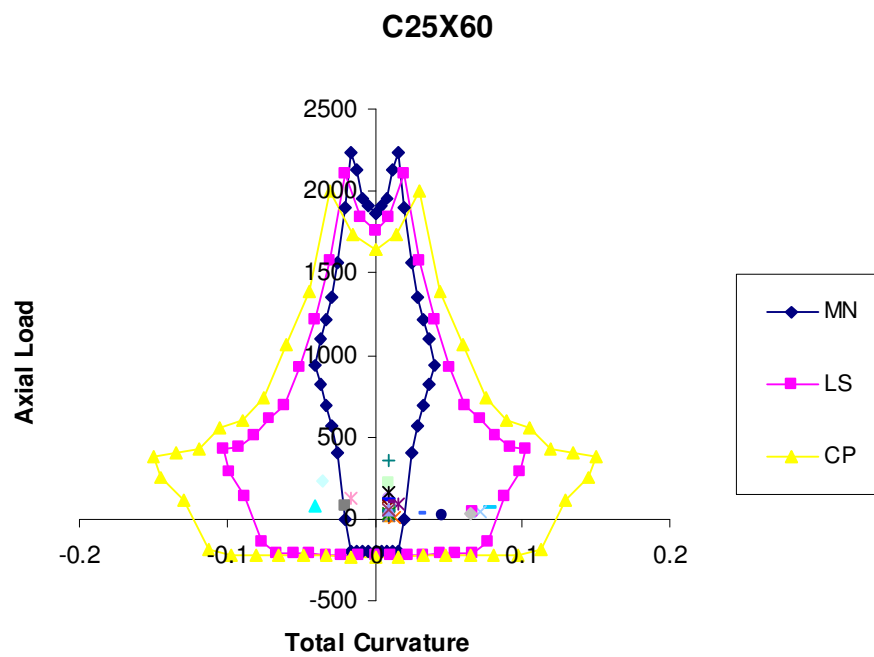

Figure 4.48. Performance assessment of C25x60 section

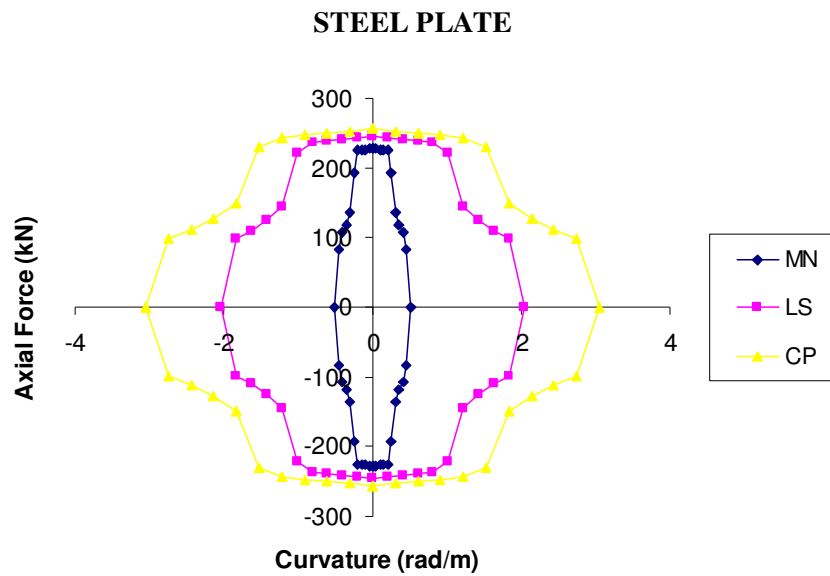

Figure 4.49. Performance assessment of plate section

#### 4.24. Assessment of Performance Level

Whole structure took into account this system is between “*Minimum Damage*” and “*Life Safety*” damage level. This region is called “*Observed Damage Zone*” in Turkish seismic code (2007) like shown below;

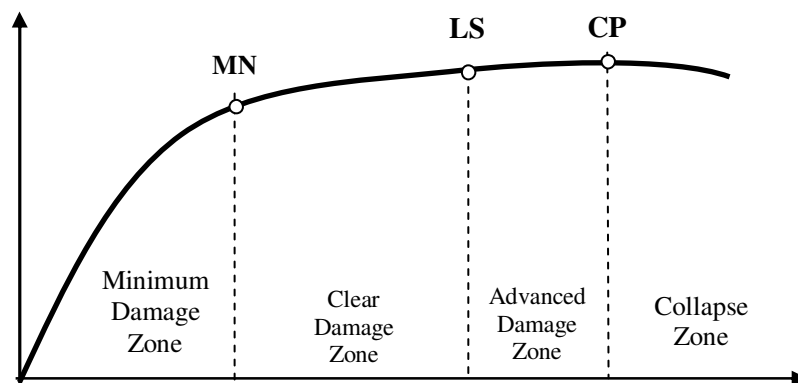

Figure 4.50. Damage zone assessment in Turkish seismic code

## 5. CONCLUSIONS

The retrofit technique proposed in this paper by using fabricated steel panels is a new finding (i.e. it is not applied before in the literature) and to test its effectiveness for retrofitting existing RC structures the early shake table test results in this paper drawn with the following conclusions;

Comparing the behavior of the specimen before and after retrofitting when they subjected to the same base excitation of maximum acceleration of 0.33g it is clear that adding the fabricated panels to the RC frame specimen results in five times reduction of story drift and an increase of the stiffness.

From measured joint column rotation and according to (TSC,2007) the performance of the reinforced concrete columns of the test specimen were improved from CP (i.e. column joint rotations 0.03 radians) in case of non retrofitted specimen to IO (i.e. column joint rotations 0.005) in case of retrofitted specimen.

It is clear that the strength of specimen was increased two times after retrofitted it by the proposed fabricated steel panels.

The proposed steel panels can be easily modeled in SAP2000 as a frame element and used to predict the pushover curve of the retrofitted structure.

The pushover analysis of the example RC building in Zeytinburnu shows that the building seismic performance was improved when it is strengthened by the proposed panels.

## REFERENCES

- ABOUTAHO, (1996). *Retrofit of Concrete Columns with Inadequate Lap Splices by the Use of Rectangular Steel Jackets*. Brussels: Earthquake Spectra.
- ATC40. (1996). *Seismic Evaluation and Retrofit of Concrete Buildings*. California: Applied Technology Council
- FEMA365. (2000). *Prestandart And Commentary For Seismic Rehabilitation O Buildings*. Washington: Federal Emergency Management Agency.
- HARRY, G. H. (1999). *Structural Modeling and Experimental Techniques*. New York: 2nd Ed, CRC Press LLC,
- KARADOGAN, MOURTAGE, SARUHAN, (1998). *ZENON Sandwich Type Shotcreted Slab Element*. Turkey: Laboratory Report.
- MOURTAGE, (2001) *Use of Shotcreted Panels For Strengthening and Construction of Low Rise Buildings*. Turkey: Civil engineering Faculty.
- PRIESTLY, M. N. J. (2003). *Myths And Fallacies in Earthquake Engineering*. The Mallet Milne Lecture.
- SAP2000. (1976-2007). *Static And Dynamic Finite Element Analysis of Structures*. Berkeley: Computers and Structures, Inc.
- TSC. (2007). *Specification for Buildings to be Built in Disaster Areas*. Istanbul: Mimistry of Public Works and Settlement Government of Republic of Turkey.
- X-TRACT. (2003). *Cros-Secion Analysis Program*. USA: Imbsen And Associates, Inc.