

APPLICATION OF BIOLOGICAL ACTIVATED CARBON (BAC) IN DRINKING
WATER TREATMENT

by

Kozet Yapsaklı

BS. in Env. Eng. Marmara University, 1999

M.S. in Env. Eng. Marmara University, 2002

Submitted to the Institute of Environmental Sciences in partial fulfillment of

the requirements for the degree of

Doctor

of

Philosophy

in

Environmental Technology

Boğaziçi University

2008

Dedicated to my family...

Their love and faith continue to be great sources of inspiration to me.

ACKNOWLEDGEMENTS

I wish to express my sincere thanks to Prof. Dr. Ferhan Çeçen for the opportunity to start and complete this research and for her guidance and support during all these years I have been in graduate program.

I would like to thank the members of my research committee, Prof. Dr. Ömer Akgiray, Assoc. Prof. Dr. Nadim Copty, Prof. Dr. Ayşen Erdinçler and Prof. Dr. Bahar İnce for providing their valuable time, effort and input to this research.

Dr. Bülent Mertoğlu deserves a special mention for always helping when I had a problem and for encouraging me during the final months. Also, one more time thanks to him for sharing his knowledge about molecular tools and for helping me in molecular analyses.

I want to thank all of my friends in Marmara University Environmental Engineering for their help and support. A special thanks to our undergraduate students Begüm Aydoğan, Çiğdem Aliyazıcıoğlu, Selen Solak and Sibel Çetin for their help in the laboratory works.

The financial support of this study by the Research Fund of Boğaziçi University (Project No: B.A.P. 05Y103D) and TUBITAK (Project No: ICTAG Ç110, Project No: ÇAYDAG 108Y101) is gratefully acknowledged.

Special thanks to Prof. Dr. Wolfgang Uhl for sharing his knowledge about his biofiltration model and feeling me comfortable during my stay in Dresden / Germany.

Lastly, I would like to express my thankfulness to my parents for their never ending love, constant encouragement and support. Without their continuous support, this work would never have seen the light of day.

ABSTRACT

Biological filtration represents an important process step for the production of high quality drinking water. Bacteria attached to the filter media as biofilm use biodegradable organic matter (BOM) present in the filter influent as a source of carbon and energy. The decrease of BOM levels through biofiltration is important with respect to the prevention of bacterial growth and related problems in the distribution system. The research presented in this thesis examined the applicability of biological activated carbon filtration using the water from the Ömerli Reservoir. The experimental results showed that, the choice of filter material is crucial in BAC systems. The ability of GAC to better adsorb and retain organic compounds increases their chance of being biodegraded by bacteria. Biological activity extended the service life of GAC columns. Thermally activated carbons adsorbed NOM better than chemically activated carbon. Likewise, this better adsorption resulted in higher biodegradation. DOC biodegradation was high and was related to the low specific ultraviolet absorption (SUVA) values in raw water. In the case of low SUVA values, ozonation may not be necessary to increase biodegradability of water. High nitrification efficiencies were observed in BAC columns filled with chemically and steam activated carbons. In-situ and membrane hybridization results indicated that *Nitrosomonas* species were the dominant ammonia oxidizing bacteria and *Nitrospira*-related species were the prevailing nitrite oxidizing bacteria. The results suggest that the real-time PCR analysis, the *amoA*/16S rRNA ratio, is an alternative method to understand nitrifying bacterial population and activity in BAC columns.

ÖZET

İçme sularında biyolojik filtrasyon yüksek kalitede su üreten önemli proseslerden biridir. Filtrede bulunan bakteri, sudaki biyolojik olarak ayrıştırılabilir organik maddeyi (BÇOK), karbon ve enerji kaynağı olarak kullanarak karbon yüzeyinde bakteriyel açıdan aktif bir tabaka oluşturur. Bu durumda, içme suyundaki organik karbon biyolojik olarak giderilir. Biyolojik olarak ayrıştırılabilir organik maddelerin giderilmesi içme suyu dağıtım şebekelerinde bakteri üremesi ve buna bağlı problemlerin giderilmesinde başlıca metot olarak görülmektedir. Bu tezin amacı, içme suyundaki organik maddenin biyolojik aktif karbon (BAK) süreci ile arıtılabilirliğini test etmektir. Bu amaçla Ömerli Rezervuarı suyu kullanılmıştır. BAK kolonları üzerindeki biyolojik aktivite aktif karbonun kullanım zamanını artırmıştır. Deneysel sonuçlar uygun Granüler aktif karbon (GAK) tipinin seçilmesinin BAK sistemlerinin başarısındaki en önemli etkenlerden biri olduğunu göstermiştir. Isı ile aktive edilmiş aktif karbon tiplerinin, kimyasal olarak aktive edilmiş tiplere göre NOM'u daha iyi adsorbladığı görülmüştür. Bu çalışmada yüksek biyolojik organik madde giderimi gözlemlenmiştir ve bu durumun ham sudaki SUVA değerlerinin düşük olması ile bağlantılı olduğu görülmüştür. GAK parçacıklarının organik maddeyi daha iyi adsorplayarak sistemde tutması, bakteri tarafından biyolojik olarak ayrıştırılma şansını artırmaktadır. Spesifik Ultraviyole Absorbans (SUVA) değerlerinin ham suda 2.5'tan küçük olması, biyolojik olarak arıtılabilirliğini artırmaktadır. SUVA değerlerinin küçük olması durumunda biyolojik olarak arıtılabilirliği artırmak için ozonlama yoluna gidilmeyebilir. Her iki GAK tipinde yüksek nitrifikasyon verimleri gözlemlenmiştir. FISH ve Slot-Blot deneylerinde *Nitrosomonas* ve *Nitrospira* bakterilerinin yaygın olarak kolonlarda bulunduğu gözlemlenmiştir. Çalışmamızda real-time PCR metodu, nitrifikasyon bakteri popülasyonu ve aktivitesini BAK kolonlarında tespitinde *amoA/16S* rRNA oranının başarılı bir şekilde kullanılabileceğini ortaya konmuştur.

TABLE OF CONTENTS

ACKNOWLEDGEMENTS.....	iv
ABSTRACT.....	v
ÖZET	vi
TABLE OF CONTENTS	vii
LIST OF FIGURES.....	xii
LIST OF TABLES	xviii
LIST OF SYMBOLS/ABBREVIATIONS.....	xix
1. INTRODUCTION.....	1
2. THEORETICAL BACKGROUND	3
2.1. Natural Organic Matter (NOM).....	3
2.1.1. Characterization of NOM.....	5
2.1.2. Chemical Characteristics of NOM.....	6
2.1.3. Effects of Conventional Treatment on NOM	7
2.1.4. Fractionation of NOM.....	8
2.1.4.1. Biodegradable Organic Matter (BOM)	9
2.1.5. NOM Removal.....	11
2.2. Granular Activated Carbon	13
2.2.1. Activated Carbon	13
2.2.2. Base Materials	15
2.2.3. Activation	15
2.2.4. Surface Chemistry of Activated Carbon	15
2.2.5. Reversible versus Irreversible Adsorption	16
2.2.6. NOM Adsorption	17
2.3. Biological Activated Carbon	21
2.3.1. Microbial Attachment to Surfaces	21
2.3.2. Microorganisms in Biofilms of Biological Filters.....	22
2.3.3. Biofilms in Drinking Water Biofilters	23
2.3.4. Ozone – Biological Activated Carbon System.....	26
2.3.5. Effects of Ozonation on Chemical Properties of NOM	28
2.3.6. Effect of Ozonation on Adsorptive Properties of NOM	28

2.3.7. Factors Affecting Biological Performance.....	29
2.3.7.1. Effect of Ozone Dose.	29
2.3.7.2. Effect of Filter Media.	30
2.3.7.3. Effect of Contact Time.	31
2.3.7.4. Effect of Backwashing.	33
2.3.7.5. Effect of Temperature.....	33
2.3.7.6. Effect of Oxidants in Filter Influent	34
2.3.8. Bioregeneration in BAC Columns	35
2.3.9. Desorption of Organic Compounds and Bioavailability	38
2.4. Modeling Biological NOM Removal in Drinking Water Treatment Filters.....	38
2.5. Nitrification in Biological Activated Carbon Column Systems	45
2.5.1. Nitrification Fundamentals.....	45
2.5.2. Ammonia in Drinking Water.....	46
2.5.3. Nitrification in Biofilters	48
2.6. Molecular Tools for Identification of Microorganisms	51
2.6.1. Polymerase Chain Reaction (PCR).....	52
2.6.2. Denaturing Gradient Gel Electrophoresis (DGGE)	54
2.6.3. Fluorescence In Situ Hybridization (FISH).....	56
2.6.4. Slot-Blot Hybridization	57
2.6.5. Real-time PCR.....	58
3. STATEMENT OF THE PROBLEM.....	60
4. MATERIALS AND METHODS	63
4.1. Batch Adsorption and Desorption Experiments	63
4.1.1. Reagents and Materials	63
4.1.1.1. Indigo Reagent.	63
4.1.1.2. Total Organic Carbon Standard	64
4.1.1.3. Granular Activated Carbon.....	64
4.1.2. Analytical Methods	65
4.1.2.1. Ozone Measurement.....	65
4.1.2.2. Total Organic Carbon Measurement.	66
4.1.2.3. Absorbance Measurements.....	67
4.1.3. Experimental Procedures.....	67
4.1.3.1. Determination of Optimum Ozone Dosage.	67

4.1.3.2. BDOC Measurement.	68
4.1.3.3. Determination of Point of Zero Charge (pH _{PZC}).	68
4.1.3.4. Surface Acidity of GAC 69	69
4.1.3.5. NOM Charge..... 70	70
4.1.3.6. Adsorption Experiments. 71	71
4.1.3.7. Desorption Experiments. 72	72
4.2. Optimization of BDOC Measurement 76	76
4.2.1. Reagents and Materials 76	76
4.2.2. Analytical Methods 76	76
4.2.2.1. BDOC Measurement. 76	76
4.3. Continuous-Flow Operation of BAC columns 78	78
4.3.1. Experimental Setup 78	78
4.3.1.1. Batch Suspended Growth Culture. 78	78
4.3.1.2. Column Setup..... 79	79
4.3.2. Experimental Methods 84	84
4.3.2.1. Dissolved Oxygen and pH Measurements..... 84	84
4.3.2.2. Preparation for DOC Measurements. 84	84
4.4. Molecular Microbiological Studies 85	85
4.4.1. Sample Collection and Preparation..... 85	85
4.4.2. DNA Extraction 86	86
4.4.3. Polymerase Chain Reaction (PCR)..... 87	87
4.4.4. Denaturing Gradient Gel Electrophoresis (DGGE) 89	89
4.4.5. Cloning and Sequencing..... 90	90
4.4.6. Fluorescence In Situ Hybridization (FISH)..... 91	91
4.4.7. Slot-Blot Hybridization 94	94
4.4.8. Real-time PCR analysis..... 95	95
4.5. Morphological Studies by Environmental Scanning Electron Microscopy (ESEM)..... 96	96
5. RESULTS AND DISCUSSION 97	97
5.1. Characterization of Raw Water Samples 97	97
5.1.1. Water Quality Parameters 97	97
5.1.2. Ozone Demand of Raw Water..... 98	98
5.1.3. UV–Visible Absorbance Spectrum of Raw Water 100	100
5.1.4. Optimum Ozone Dosage for Maximum Biodegradability 101	101

5.1.5. Change in Absorption Spectrum upon Ozonation	104
5.2. Batch Adsorption – Desorption Experiments.....	107
5.2.1. Charge on NOM.....	107
5.2.2. Point of Zero Charge (pH_{PZC}) of Several GAC Grades	109
5.2.3. Boehm Titrations	110
5.2.4. Equilibration Time for Adsorption and Desorption.....	110
5.2.5. Adsorption Isotherms	112
5.2.6. Desorption Isotherms	123
5.3. Optimization of BDOC Measurement	129
5.3.1. BDOC Exertions of Standard Solutions.....	130
5.3.2. BDOC Exertions of NOM Samples.....	133
5.4. Continuous-Flow Column Experiments.....	136
5.4.1. Enrichment of Inoculum for BAC Columns	136
5.4.2. Choosing the Most Suitable GAC Type for Biofilters.....	140
5.4.3. Continuous-Flow Column Operations	141
5.4.3.1. Comparison of DOC Removal in GAC and BAC Columns.....	142
5.4.3.2. Sampling from the Ports of Sterile GAC Columns.....	146
5.4.3.3. BAC Columns	149
5.4.3.4. Operation of CAgran.	149
5.4.3.5. Operation of Norit 1240	170
5.4.3.6. Comparison of Biodegradation Efficiencies in the Norit 1240 and CAgran Columns	173
5.4.3.7. Effect of Ozone on Removal Efficiency.	177
5.4.3.8. ESEM Pictures	177
5.4.4. Modeling DOC Biodegradation with Uhl’s Model	180
5.5. Nitrification in BAC Columns and Molecular Investigation of Nitrifying Bacteria	183
5.5.1. Column Operation.....	183
5.5.2. Molecular Investigation of Nitrifying Population	193
5.5.2.1. Fluorescent in-situ Hybridization (FISH).....	195
5.5.2.2. Slot-Blot Hybridization.	196
5.5.2.3. Real-time PCR	198
5.5.2.4. DGGE.....	203

6. CONCLUSIONS AND RECOMMENDATIONS.....	206
7. REFERENCES.....	210
TOC AND TN CALIBRATION CURVES	240
LANGMUIR ISOTHERMS BASED ON DOC MEASUREMENTS.....	241
FREUNDLICH ISOTHERMS BASED ON UV MEASUREMENTS.....	242
ESEM IMAGES OF SAMPLES TAKEN FROM BAC COLUMNS	244
SIMULATION RESULTS OF UHL'S MODEL	246
ATTACHMENT: CD-ROM: ESEM AND FISH PICTURES	

LIST OF FIGURES

Figure 2.1	Fractionation of organic matter (Volk and LeChevallier, 2000).....	8
Figure 2.2	Electron microscope photos of a GAC particle (Sontheimer et al., 1988) ..	14
Figure 2.3	Adsorption column (a) Column with MTZ (b) Column without MTZ (Snoeyink and Summers, 1999)	18
Figure 2.4	Adsorption column breakthrough curve (Snoeyink and Summers, 1999)...	19
Figure 2.5	Effect of biodegradation and presence of nonadsorbable compounds on the shapes of breakthrough curves (Snoeyink and Summers, 1999)	20
Figure 2.6	Schematic diagram that illustrates the processes occurring in a biofilter (Hozalski and Bouwer, 2000)	26
Figure 2.7	Concentration Profiles at Different Times during Bioregeneration (Andrews and Tien (1981) and Speitel (1985)).....	36
Figure 2.8	Transformations of nitrogen in biological systems	46
Figure 2.9	Overview of polymerase chain reaction (PCR) principles.	53
Figure 2.10	Overview of denaturing gradient gel electrophoresis experiment.....	55
Figure 2.11	Overview of fluorescence in situ hybridization (FISH) steps.....	56
Figure 2.12	Overview of slot-blot hybridization experiment.	58
Figure 4.1	Processes applied to the water samples prior to adsorption and desorption experiments	74
Figure 4.2	The overall adsorption experiments	75
Figure 4.3	Batch reactor used to enrich the microorganisms in Ömerli water	79
Figure 4.4	Experimental setup used in biofiltration experiments	81
Figure 4.5	BAC setup	83
Figure 4.6	View of columns at the first day and at 187 th day of operation	84
Figure 4.7	Procedures for molecular identification.....	85
Figure 4.8	Phylogenetic tree inferred from comparison of 16S rRNA sequences. Target organisms for probes Nso190, Nso1225, Nsm156, Nsv443, NEU, NIT3, and Nb1000 are indicated by brackets. The bar represents 0.1 estimated change per nucleotide.	93
Figure 5.1	Change in ozone concentration with applied ozone	99

Figure 5.2	UV-Visible absorbance spectrum of the raw and ozonated (2 mgO ₃ /mgDOC) water	101
Figure 5.3	DOC profiles of the ozonated water samples during BDOC test.....	102
Figure 5.4	BOD observed with respect to ozone dosage.....	103
Figure 5.5	Relationship between the (a)UV ₂₅₄ (b) UV ₂₈₀ absorbance (c) SUVA and biodegradability as shown by BDOC	105
Figure 5.6	Surface charge of NOM in different water samples between pH 3-9	108
Figure 5.7	Surface charge of the activated carbon samples.....	109
Figure 5.8	Adsorption equilibrium time for raw water samples	111
Figure 5.9	Desorption equilibrium time for raw water samples	112
Figure 5.10	Freundlich isotherms of Norit 1240 (I: Nonadsorbable fraction left over at high GAC doses, II: Adsorption at medium doses, III: Adsorption at low GAC doses)	113
Figure 5.11	Freundlich isotherms of Row Supra (I: Nonadsorbable fraction left over at high GAC doses, II: Adsorption at medium doses, III: Adsorption at low GAC doses)	114
Figure 5.12	Freundlich isotherms of HD 4000 (I: Nonadsorbable fraction left over at high GAC doses, II: Adsorption at medium doses, III: Adsorption at low GAC doses)	114
Figure 5.13	Freundlich isotherms of Cagran (II: Adsorption at medium doses)	115
Figure 5.14	Freundlich adsorption isotherms belonging to II. Region (Adsorption at medium doses) for raw water.....	117
Figure 5.15	Freundlich adsorption isotherms belonging to II. Region (Adsorption at medium doses) for ozonated water.....	117
Figure 5.16	Freundlich adsorption isotherms belonging to II. Region (Adsorption at medium doses) for biologically treated water	118
Figure 5.17	Freundlich adsorption isotherms belonging to II. Region (Adsorption at medium doses) for ozonated - biologically treated water.....	118
Figure 5.18	Relationship between the acidic surface functional groups and adsorption	122
Figure 5.19	Correlation between the DOC and UV ₂₅₄ in raw and ozonated water.....	123
Figure 5.20	Desorption isotherms for raw water	125
Figure 5.21	Desorption isotherms for ozonated water	125

Figure 5.22	Desorption isotherms for biologically treated water	126
Figure 5.23	Desorption isotherms for ozonated - biologically treated water	126
Figure 5.24	BDOC exertion for 1 mg/L Acetate-C.....	131
Figure 5.25	BDOC exertion for 2.5 mg/L Acetate-C.....	132
Figure 5.26	BDOC exertion for 5 mg/L Acetate-C.....	133
Figure 5.27	BDOC exertion for the raw water samples	134
Figure 5.28	BDOC exertion for the ozonated water samples	135
Figure 5.29	Daily influent and effluent DOC profiles of the batch reactor between days 0-40	137
Figure 5.30	Daily influent and effluent DOC profiles of the batch reactor between days 40-140	138
Figure 5.31	Daily influent and effluent NH_4^+ -N profiles of the batch reactor	139
Figure 5.32	Normalized DOC in the effluent of sterile GAC and BAC of CAgran.....	142
Figure 5.33	Normalized DOC in the effluent of sterile GAC and BAC of Norit1240 .	144
Figure 5.34	Influent and effluent NH_4^+ -N concentrations in sterile GAC columns	145
Figure 5.35	Influent and effluent NO_3^- -N concentrations in sterile GAC columns.....	145
Figure 5.36	Concentrations along the length of the sterile Norit 1240 column fed with raw water.....	147
Figure 5.37	Concentrations along the length of the sterile CAgran column fed with raw water	148
Figure 5.38	Influent and effluent DOC concentrations in the two continuous-flow BAC columns (CAgran and Norit 1240) tested with raw and ozonated water (RW: Raw Water; OW: Ozonated Water).....	150
Figure 5.39	Influent and effluent BDOC values of the continuous-flow BAC columns tested with raw water (RW: Raw Water).....	153
Figure 5.40	Influent and effluent BDOC values of the continuous-flow BAC columns tested with ozonated water.....	154
Figure 5.41	Concentrations along the length of the CAgran fed with raw water at different bed volumes (10000 BV corresponds to 125 days after start-up)	156
Figure 5.42	Concentrations along the length of the CAgran fed with raw water at different bed volumes (10000 BV corresponds to 125 days after start-up)	157
Figure 5.43	Percent biodegradability of raw water and ozonated water	161

Figure 5.44	Influent and effluent UV_{254} concentrations in continuous-flow BAC columns tested with raw water.....	162
Figure 5.45	Influent and effluent UV_{254} concentrations in continuous-flow BAC columns tested with ozonated water.....	163
Figure 5.46	Influent and effluent UV_{280} concentrations in continuous-flow BAC columns tested with raw water.....	164
Figure 5.47	Influent and effluent UV_{280} concentrations in continuous-flow BAC columns tested with ozonated water.....	165
Figure 5.48	Influent SUVA values in raw and ozonated water.....	166
Figure 5.49	Relationship between SUVA and DOC biodegradation in raw water.....	167
Figure 5.50	The overall average removal in terms of specific parameters (RW: Raw Water, OW: Ozonated Water).....	168
Figure 5.51	Influent and effluent pH values of the continuous-flow BAC columns (RW: Raw Water, OW: Ozonated Water).....	169
Figure 5.52	Concentrations along the length of the Norit 1240 fed with raw water at different bed volumes (10000 BV corresponds to 125 days after start-up)	171
Figure 5.53	Concentrations along the length of the Norit 1240 fed with ozonated water at different bed volumes (10000 BV corresponds to 125 days after start-up).....	172
Figure 5.54	ESEM picture of the virgin CAgran.....	178
Figure 5.55	ESEM picture of the CAgran at the 240th day of operation.....	178
Figure 5.56	ESEM picture of the virgin Norit 1240.....	179
Figure 5.57	ESEM picture of the Norit 1240 at the 240th day of operation.....	179
Figure 5.58	Comparison of model simulation with experimental data from the CAgran column fed with ozonated water at Day 130.....	181
Figure 5.59	Comparison of model simulation with experimental data from the CAgran column fed with ozonated water at Day 185.....	181
Figure 5.60	Influent and effluent NH_4^+ -N values of the continuous-flow BAC columns tested with raw and ozonated water (RW: Raw Water, OW: ozonated Water).....	184
Figure 5.61	Influent and effluent NO_2^- -N values of the continuous-flow BAC columns tested with raw and ozonated water (RW: Raw Water, OW: Ozonated Water).....	187

Figure 5.62	Influent and effluent NO_3^- -N values in the continuous-flow BAC columns tested with raw water	189
Figure 5.63	Influent and effluent NO_3^- -N values in the continuous-flow BAC columns tested with ozonated water	190
Figure 5.64	Influent and effluent TN values in the continuous-flow BAC columns tested with raw water	191
Figure 5.65	Influent and effluent TN values in the continuous-flow BAC columns tested with ozonated water	192
Figure 5.66	In situ identification of nitrifiers in Norit 1240 fed with raw water at Day 125. Samples were hybridized with <i>Nitrosomonas</i> and <i>Nitrospira</i> -specific probes (labeled with Cy3). All microorganisms stained with DAPI (blue). Blue and red couples represent the same fields of the microscopic view..	196
Figure 5.67	Relative differences of NOB in BAC columns. Intensity of the bands is directly proportional to the amount of target DNA. For efficient comparison DIG labeled 1 ng pBR328 control DNA (linearized with BamHI) was applied to each membrane.....	197
Figure 5.68	The ratios of <i>amoA</i> /16S rRNA in BAC column samples (RW: Raw Water, OW: Ozonated Water)	200
Figure 5.69	Quantitative real-time PCR data and construction of (a) universal 16S rRNA and (b) <i>amoA</i> amplification standard curves. DNA standards are expressed as gene copy numbers.	202
Figure 5.70	DGGE profiles of PCR-amplified <i>amoA</i> gene fragments retrieved from 5 different samples.	203
Figure 5.71	A neighbor-joining trees of <i>amoA</i> clones. The significance of each branch is indicated by bootstrap values. The scale bar represents 0.05 inferred substitutions per nucleotide position.	204
Figure A.1	An example of TOC calibration curve.....	240
Figure A.2	An example of TN calibration curve	240
Figure B.1	Langmuir adsorption isotherms of different GACs tested with raw water	241
Figure C.1	Freundlich isotherms for the Row Supra based on UV_{254} parameter	242
Figure C.2	Freundlich isotherms for the Norit 1240 based on UV_{254} parameter	242
Figure C.3	Freundlich isotherms for the CAgran based on UV_{254} parameter.....	243
Figure C.4	Freundlich isotherms for the HD 4000 based on UV_{254} parameter.....	243

Figure D.1	Ectoparasitic Protozoa: trichodinids identified in ESEM image.....	244
Figure D.2	Worm like higher organisms found in BAC columns	244
Figure D.3	Various organisms found in BAC columns	245
Figure E.1	Simulation results of the effect of temperature on the BDOC removal along the bed depths.....	246
Figure E.2	Simulation results of the effect of hydraulic loading on the BDOC removal along the bed depth.....	246
Figure E.3	Effect of maximum specific bacterial growth rate on BDOC removal along the bed depth	247
Figure E.4	Effect of initial BDOC concentration on the removal efficiency at various bed depths with a hydraulic loading of 1m/h.....	247

LIST OF TABLES

Table 2.1	Important Functional Groups in Dissolved Organic Carbon (Thurman, 1985)	6
Table 2.2	Main GAC product families in potable water treatment	15
Table 4.1	Properties of activated carbon grades used in the study	65
Table 4.2	Potentiometric endpoint pHs of alkalimetric titrations.....	70
Table 4.3	Summary of studies examining biological drinking water filters	80
Table 4.4	Biological Activated Carbon (BAC) set-up in this study	81
Table 4.5.	Experimental analyses and their measurement methods	84
Table 4.6	Amplification primer pairs used in polymerase chain reaction (PCR).....	88
Table 4.7	Oligonucleotide probes and hybridization conditions applied in this study	92
Table 4.8	Fluorescent microscope filter sets	94
Table 5.1	Raw water characterization	98
Table 5.2	Characterization of organic content based on absorption measurements..	104
Table 5.3	Surface functional groups on GACs used in this study	110
Table 5.4	Freundlich adsorption isotherm constants belonging to II. Region: Adsorption at medium doses.....	119
Table 5.5	Freundlich desorption isotherm constants	127
Table 5.6	Modifications to the original BDOC method.....	129
Table 5.7	Comparison of average DOC biodegradation with influent biodegradable DOC (BDOC) concentration.....	152
Table 5.8	Examples of the calculation of the theoretical and actual oxygen consumptions.....	159
Table 5.9	DOC removals typically achieved by pre-ozonation-biofiltration.....	176
Table 5.10	Simulation parameters for Uhl's Model	180
Table 5.11	Sampling information for Slot-Blot Hybridization and DGGE	194
Table 5.12	Semi-quantitative slot blot hybridization results in a BAC Column.....	198
Table 5.13	Copy numbers of <i>amoA</i> and 16S rRNA genes and the ratios of <i>amoA</i> /16S rRNA in BAC column samples as determined by real-time PCR assay. ..	199
Table B.1	Langmuir coefficients of different GACs.....	241

LIST OF SYMBOLS/ABBREVIATIONS

Symbol	Explanation	Units used
AMO	Ammonia Monooxygenase	
ANAMMOX	Anaerobic Ammonia Oxidation	
AOB	Ammonia Oxidizing Bacteria	
AOC	Assimilable Organic Carbon	(mg L ⁻¹)
BAC	Biological Activated Carbon	
bCc	Bacterial Content per Unit of Biovolume	(mg.µm ⁻³)
BDOC	Biodegradable Dissolved Organic Carbon	(mg L ⁻¹)
BOD ₅	Biochemical Oxygen Demand	(mg L ⁻¹)
BOM	Biodegradable Organic Matter	
BV	Bed Volume	
bV	Mean Biovolume of the Heterotrophs	(µm ³)
CFU	Colony Forming Unit	
COD	Chemical Oxygen Demand	(mg L ⁻¹)
DIG	Digoxigenin	
DBPs	Disinfection By-Products	
DBPs	Disinfection By-Products	
DGGE	Denaturing Gradient Gel Electrophoresis	
DOC	Dissolved Organic Carbon	(mg L ⁻¹)
E _a	Arrhenius Activation Energy	(J.mol ⁻¹)
ε _{bed}	Filter Porosity	
EBCT	Empty Bed Contact Time	(min)
ESEM	Environmental Scanning Electron Microscope	
FISH	Fluorescence In Situ Hybridization	
GAC	Granular Activated Carbon	
HAA	Haloacetic Acid	
HAO	Hydroxylamine Oxidoreductase	
k _d	Decay Coefficient of Bacteria	(h ⁻¹)

$k_{\text{prot,gr}}$	Growth Rate Coefficient of Protozoa	(ml.CFU ⁻¹ .h ⁻¹)
K_s	Monod-Half Rate Constant	(mg L ⁻¹)
L_{MTZ}	Length of Mass Transfer Zone	
μ_{max}	Maximum Growth Rate of Bacteria	(h ⁻¹)
MCL	Maximum Contaminant level	
MLVSS	Mixed Liquor Volatile Suspended Solids	(mg L ⁻¹)
MPN	Most Probable Number	
m_s	Maintenance Coefficient	
MTZ	Mass Transfer Zone	
NDIR	Non Dispersive Infrared	(CFU.ml ⁻¹)
N_{P17}	Concentration of <i>Pseudomonas fluorescens P17</i>	
N_{NOX}	Concentration of <i>Spirillum NOX</i>	
NOB	Nitrite Oxidizing Bacteria	
NOM	Natural Organic Matter	
PCR	Polymerase Chain Reaction	
pH_{PZC}	Point of Zero Charge	
R_0	Universal Gas Constant	
$r_{\text{prot,gr}}$	Rate of Protozoan Proliferation	(CFU.h ⁻¹ .ml ⁻¹)
$r_{\text{s,cat}}$	Production Rate of the Biodegradable Substrate by Surface Catalytic Processes	(mg.L ⁻¹ .d)
$r_{\text{s,gr}}$	Rate of Substrate Consumption by Bacterial Growth	(mg.L ⁻¹ .d)
$r_{\text{s,maint}}$	Rate of Substrate Consumption by Maintenance Requirements	(mg.L ⁻¹ .d)
$r_{\text{x,att}}$	Bacterial Attachment Rate to the Surfaces	(CFU.h ⁻¹ .ml ⁻¹)
$r_{\text{x,det}}$	Bacterial Detachment Rate	(CFU.h ⁻¹ .ml ⁻¹)
$r_{\text{x,gr}}$	Rate of Bacterial Proliferation	(CFU.h ⁻¹ .ml ⁻¹)
$r_{\text{x,mort}}$	Rate of Bacterial Mortality	(CFU.h ⁻¹ .ml ⁻¹)
$r_{\text{x,graz}}$	Rate of Bacterial Decimation by Grazing Protozoa	(CFU.h ⁻¹ .ml ⁻¹)
RSD	Relative Standard Deviation	(%)
SCFH	Standard Cubic Feet per Hour	(ft ³ h ⁻¹)

THM	Trihalomethanes	
TN	Total Nitrogen	(mg L ⁻¹)
TOC	Total Organic Carbon	(mg L ⁻¹)
X _{att,max}	Maximum Attached Bacteria Concentration	(CFU.mL ⁻¹)
X _{sus}	Suspended Bacteria Concentration	(CFU.mL ⁻¹)
Y _{P17}	Yield Coefficient for <i>Pseudomonas fluorescens</i> <i>P17</i>	(μg C.CFU ⁻¹)
Y _{x/s}	Yield Coefficient	(mg bC.mg DOC ⁻¹)
Y _{NOX}	Yield Coefficient for <i>Spirillum NOX</i>	(μg C.CFU ⁻¹)

1. INTRODUCTION

The presence of organic and inorganic electron donors in water causes significant problems such as trihalomethane formation following disinfection with chlorine, taste and odor problems, regrowth of bacteria in distribution systems, and reduced bed life of Granular Activated Carbon (GAC) columns. Several European countries (e.g., France, Germany, Netherlands) and Japan include biological processes in the treatment train in an effort to remove nutrient levels in the treated water and thus obtain biologically stable water, which limits the growth of microorganisms in distribution pipes and reservoirs.

Biological treatment (e.g., biofiltration involving, for example, biologically active GAC filters, anthracite, or sand) is based on aerobic biofilm processes that offer several advantages over physicochemical processes in regard to drinking water treatment. Granular activated carbon provides a large surface area for the accumulation of microorganisms as a biofilm. Three important factors affecting biodegradable organic matter removal by biofilters are the presence of chlorine in the backwash water, media type, and temperature.

The advantages provided by biofiltration are the following:

1. Biotreatment removes organic compounds (total and assimilable organic carbon), thus reducing bacterial growth in water distribution systems and producing biostable water.
2. Taste and odor compounds can be removed (e.g., geosmin and 2-methyl isoborneol). Ozonation followed by biofiltration provide an effective treatment for these compounds.
3. Biotreatment, using GAC filtration, can also remove ammonia from water and reduces the formation of chlorine demand (theoretical consumption is 7.6 mg of Cl_2 per mg of N-NH_4).
4. Trihalomethane precursors and other disinfection byproducts may be removed. A comparison of chemical and biological treatments shows that the latter produces drinking water with lower mutagenic activity.
5. Iron and manganese may be removed.

6. Xenobiotics (e.g., petroleum hydrocarbons, halogenated hydrocarbons, pesticides, chlorinated phenols, and benzenes) may be biodegraded and removed.

In this study, the applicability of biological activated carbon was tested for the water of Ömerli Reservoir with regard to Dissolved Organic Carbon (DOC) bio-removal. In order to investigate the applicability, batch adsorption and desorption isotherm experiments were done to choose the optimum type of GAC. Afterwards, continuous-flow biofiltration experiments were conducted with the chosen GAC types. The impact of ozonation and GAC type on biodegradation efficiencies in biological activated carbon (BAC) columns were evaluated. Finally, nitrification in BAC columns was studied and a molecular investigation was done with respect to nitrifying bacteria using fluorescence in situ hybridization (FISH), slot-blot hybridization, polymerase chain reaction (PCR) and denaturing gradient gel electrophoresis (DGGE) techniques. These results were compared and evaluated with the data of real-time PCR, cloning and DNA sequencing data.

In Chapter 1, a brief description of the biological activated carbon is given along with the aim of thesis. Chapter 2 provides the theoretical background information from relevant literature. In Chapter 3, the main reasons of dealing with this subject are briefly explained. The objectives and methodology of the study are also presented in this chapter. Chapter 4 provides all the information about the materials and methods. Chapter 5 presents the main findings of this study and consists of three sections. The first section of Chapter 5 includes the characterization of Ömerli water and includes the batch adsorption and desorption isotherm experiments. The second section in Chapter 5 includes biofiltration experiments for the removal of DOC and ammonium nitrogen. In the last part of Chapter 5, molecular identification of nitrifying bacteria in BAC columns is presented. Finally, Chapter 6 provides conclusions and discussions about the significance of research. The chapter ends with recommendations and suggestions for future research.

2. THEORETICAL BACKGROUND

Pertinent literature concerning the granular activated carbon (GAC) adsorption, natural organic matter (NOM), biological activated carbon (BAC) in drinking water are reviewed in this chapter. The purpose of this review is to survey relevant background information to evaluate the state of art with respect to biofiltration for use in drinking water treatment.

2.1. Natural Organic Matter (NOM)

Natural organic matter (NOM) is the all-encompassing term used to describe the non-synthetic organics ubiquitously present in surface waters (Moore, 2000). NOM is generally recognized as a complex mixture of organic acids with small amounts of neutral and basic components present in natural waters (Glaze, 1990). Most of these materials result from the decomposition of biological material. Physicochemical composition of NOM is influenced by several biogeochemical processes occurring in aquatic environments. These include fixation of carbon by algae and aquatic plants, transformation and biodegradation of organic materials, partitioning between solid and liquid phases, photodegradation, and oxidation (Aiken and Cousaris, 1995). In addition, runoff and storm events flushing organic matter from soil and plant debris, diffusion from sediments, and living or decayed vegetation are also major contributors to the organic matter matrix in natural waters (Krasner et al., 1996).

NOM consists of humic and non-humic fractions. The humic fraction is more hydrophobic than the non-humic fraction (Liao et al., 1982) and it comprises humic and fulvic acids having carboxylic and phenolic moieties (Kitis, 2001). On the other hand, the non-humic fraction is more hydrophilic and includes biochemically well-defined compounds such as hydrophilic acids, proteins, lipids, aminoacids and carbohydrates. Humic substances are complex and multi-component in nature and cannot be described in specific molecular terms. Humic substances in NOM are about 50% and may be as high as 50-90% in highly colored waters. Therefore, humic substances may be the most important NOM and should be eliminated from drinking water sources. Other constituents of NOM

(e.g., amino acids, carbohydrates, carboxylic acids) are generally present in such low concentrations that qualitative and quantitative analyses of specific molecules are difficult (Volk and LeChevallier, 2000). As a result of its heterogeneous and ill-defined character, the amount of organic matter is usually expressed in terms of the concentration of total organic carbon (TOC) or dissolved organic carbon (DOC) (Yavich et al., 2004). Most methods for measuring DOC in water are based on high-temperature catalytic oxidation, ultraviolet/persulphate oxidation or some combination of these processes.

The presence of NOM has significant impacts on the water quality in natural and engineered systems. Geochemical processes in aquatic systems are often controlled by NOM due to its role as proton donor and/or acceptor and as pH buffer, its effect on the transport and degradation of pollutants, and its precipitation in mineral dissolution and precipitation reactions. NOM may control the depth of photic zone in surface waters, influence the bioavailability of nutrients, and serve as a carbon source for the microbial growth (Aiken and Cotsaris, 1995). NOM can also bind microbially significant substrates such as carbohydrates and proteins (Steinberg and Muenster, 1985). NOM enhances mobilization and transport of hydrophobic organic compounds (e.g., pesticides), metals (e.g., lead, cadmium, copper and mercury) and radionucleoides (e.g., plutonium and uranium). Thus, many chemicals that are considered to be virtually immobile in aqueous systems can migrate far beyond the distances predicted by structure and activity relationships (Aiken and Cotsaris, 1995). In addition, their bioavailability and geochemical cycling can be changed after they complex with NOM (Steinberg and Muenster, 1985).

The presence of NOM in natural water poses a broad range of problems in drinking water treatment and water distribution systems. These problems relate to the ability of NOM to serve as a precursor for formation of regulated Disinfection By-Products (DBPs), to act as substrate for biological re-growth in distribution systems, to bind regulated metals and hydrophobic organic chemicals and transport them through water treatment plants and distribution systems, to cause taste and odor in drinking water, to impair the effectiveness of treatment processes (e.g., fouling of the membranes), and to exert increased coagulant and disinfectant/oxidant demands (Jacangelo et al., 1995)

For a given water source, DOC values fluctuate over time. Spatial variations in the organic matter could be related to factors such as algal blooms, rainfall, snowmelt, drought, watershed characteristics, and pollutant discharges (Volk and LeChevallier, 2002). Overall, dissolved organic matter levels fluctuate during water treatment according to a pattern that depends on the raw water characteristics and the treatment processes.

2.1.1. Characterization of NOM

It is relatively difficult to analyze and characterize NOM due to its heterogeneous and complex structure. DOM isolates or fractions obtained by reverse osmosis have been characterized using a range of proximate (e.g. elemental analysis) and sophisticated spectroscopic techniques including pyrolysis GC/MS, ^{13}C -NMR and IR/FTIR. Although these spectroscopic techniques provide insight into the composition of DOM, they are only semi-quantitative, require large quantities of DOM for analysis, and are not practical for use by treatment plant operators for in-situ assessment of changes in the DOM composition after different treatment processes (Kitis, 2001).

DOM can also be characterized by non-specific simple parameters such as specific ultraviolet absorbance (SUVA), which is the UV absorbance measured at a fixed wavelength (λ , in nm) divided by DOC concentration:

$$SUVA_{\lambda} = \frac{UV_{\lambda} (cm^{-1}) \times 100}{DOC (mg / L)} \quad (2.1)$$

UV_{λ} is usually in cm^{-1} and DOC in mg/L. A conversion factor of 100 is used to express the unit of SUVA as $m^{-1}/(mg \text{ DOC}/L)$.

Measuring the UV absorbance of DOM solutions in the range of 254-280 nm reflects the presence of unsaturated double bonds or π - π electron interactions such as in aromatic compounds (Lawrance, 1980; Traina, 1990; Novak et al., 1992, Çeçen, 1993; Çeçen and Aktaş, 2001). The magnitude of absorbance at a particular wavelength is also a function of the amount of organic carbon present in solution. Therefore, in order to compare the characteristics of different DOMs, UV absorbance at a particular wavelength

must be normalized by the DOC concentration. The normalized value is also called absorptivity or SUVA. SUVA provides a quantitative measure of unsaturated bonds and/or aromaticity within NOM. Increase in SUVA generally reflects higher humification, aromaticity and hydrophobicity of DOM.

SUVA can be determined in a short period of time, using a small volume of sample, and does not require extensive sample pretreatment. The equipment needed to make DOC and UV absorbance measurements is available in most treatment plants and straightforward to operate.

2.1.2. Chemical Characteristics of NOM

The important acidic, neutral, and basic functional groups present in dissolved organic carbon are listed in Table 2.1. Humic substances carry a negative charge at pH values typically encountered in water treatment processes, which is due primarily to the presence of carboxylic and phenolic groups.

Table 2.1 Important Functional Groups in Dissolved Organic Carbon (Thurman, 1985)

Functional Group	Structure	Where Found
	Acidic Groups	
Carboxylic acid	R-CO ₂ H	90% of all dissolved organic carbon
Enolic hydrogen	R-CH=CH-OH	Aquatic humus
Phenolic OH	Ar-OH	Aquatic humus-phenols
Quinone	Ar=O	Aquatic humus-quinones
	Neutral Groups	
Alcoholic OH	R-CH ₂ -OH	Aquatic humus, sugars
Ether	R-CH ₂ -O-CH ₂ -R	Aquatic humus
Ketone	R-C=O(-R)	Aquatic humus, volatiles, keto acids
Aldehyde	R-C=O(-H)	Sugars
Ester, lactone	R-C=O(-OR)	Aquatic humus, tannins, hydroxy acids
	Basic Groups	
Amine	R-CH ₂ -NH ₂	Amino acids
Amide	R-C=O(NH-R)	Peptides

Carboxylic acid groups are one of the most important functional groups in aquatic dissolved organic carbon, because they impart acidity and aqueous solubility upon organic

molecules (Thurman, 1985). In addition, the carboxylic acid group is chemically and biologically stable.

In the typical pH range of natural surface waters (pH 6 to 9), organic acids exist as ions and represent roughly 90% of the organic carbon in water (Thurman, 1985). When dissociated, organic acids are more soluble, which is one reason that organic acids represent such a large fraction of organic carbon in natural waters.

Because neutral functional groups contain oxygen, they can form hydrogen bonds with water, resulting in an increased solubility for compounds containing these groups.

Amines and amides are the important basic functional groups in natural organic matter. These groups are found in amino acids, polypeptides and aquatic humic substances. In general, they are important because they form hydrogen bond with water and increase solubility, however, due to their basicity, sediments sorb them (Thurman, 1985)

2.1.3. Effects of Conventional Treatment on NOM

In conventional treatment for suspended solids removal consisting of coagulation, sedimentation and rapid sand filtration processes, some part of NOM is removed. The removal efficiency of NOM may be around 30% in many cases (Randtke, 1988). Conventional treatment methods remove primarily the hydrophobic organic fraction (humic substances) and large molecules, leaving the hydrophilic compounds affected to a small extent (Jacangelo et al., 1995). The removal efficiency depends on the characteristics of the organic matter (structure, molecular size, functionality), the inorganic water matrix, and the operation and design of treatment plant (Volk and LeChevallier, 2002).

NOM reduction during coagulation, flocculation, and sedimentation is achieved through precipitation and adsorption to the floc. Some research has shown that chlorination of humic substances increased the biodegradable fraction of NOM. The number of carboxylic groups increased, and the mean size of the molecules was reduced after chlorination of fulvic acids (Hambusch et al., 1993).

The low NOM removal may have several causes. One cause may be the low SUVA of raw waters. Low SUVA values ($<4 \text{ L/mg}^{-1} \cdot \text{m}^{-1}$) denote a DOC low in humic material and difficult to remove by coagulation (Edzwald, 1994). A second cause may be that coagulation of DOC is not very effective when raw water DOC is low (Volk et al., 2000). Volk and Lechevalier (2002) observed only 10% DOC removal at a mean raw water DOC of 2.06 mg/L. A third cause may be the lack of enhanced coagulation (coagulation at low pH levels) at the plants. Enhanced coagulation has been shown to improve DOC and Biodegradable Dissolved Organic Carbon (BDOC) removals. Raw water characteristics, plant design, and cost considerations may limit the implementation of enhanced coagulation at certain sites because of lack of acid-feed equipment, difficulty in lowering the pH of high-alkalinity waters, or corrosion control processes (Volk and Lechevallier, 2002).

2.1.4. Fractionation of NOM

NOM can be divided into two fractions. The first, biodegradable organic matter (BOM), can be used by bacteria as a source of energy and carbon. The second fraction is refractory to biodegradation (e.g., nonbiodegradable) and has little effect on bacterial regrowth (Volk and LeChevallier, 2000). Fractionation of organic matter is presented in Figure 2.1.

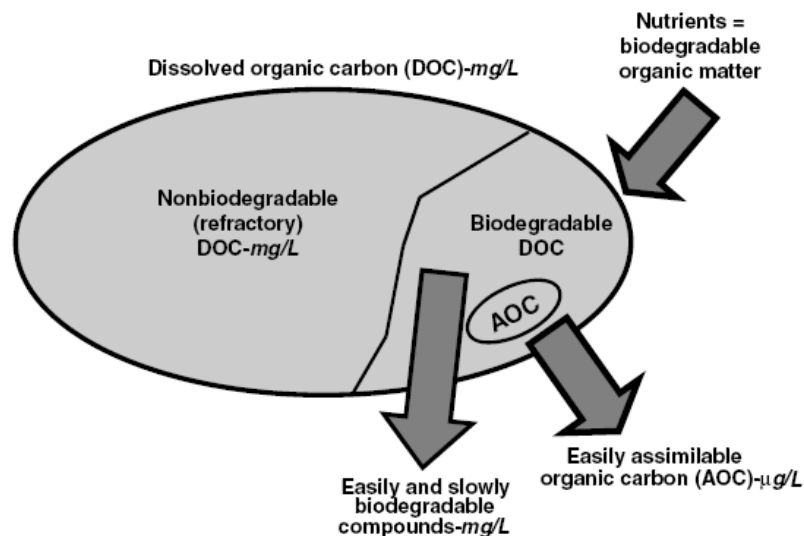


Figure 2.1 Fractionation of organic matter (Volk and LeChevallier, 2000)

Biodegradable organic materials have generally been considered to be carbohydrates and small-molecular weight compounds, whereas nonbiodegradable materials were assumed to be complex molecules such as humic substances. However, some studies have shown that this classification should be used with caution (Volk et al., 1997). Biodegradable compounds include both low- and high-molecular-weight compounds. Some low-molecular-weight molecules can be directly used for metabolism. Other compounds such as humic substances, which constitute most of the DOC, can be partially degraded by bacteria after enzymatic action.

2.1.4.1. Biodegradable Organic Matter (BOM). BOM in water promotes bacterial growth and may be related to the occurrence of coliform bacteria and organisms like *Asellus*, *Nais*, etc. (AWWA, 1995) in the protected biofilm environment and the localized loss of the chlorine residual in distribution systems (LeChevallier, 1990). Excess biological growth in a distribution system can lead to undesirable tastes and odors, corrosion (Levy et al., 1986), turbidity and consumption of dissolved oxygen (Zhang et al., 2002) and increased risk of gastroenteric illnesses (Payment et al., 1991). Reducing the concentration of BOM during treatment may be an effective way to control the bacterial quality of water without excessive use of disinfectants (Volk and LeChevallier, 2000 and Laurent et al., 1998).

BOM, as a very general definition, cannot be measured by a standard method such as BOD₅ or COD. Several biological tests have been developed to assess the level of BOM in water (Huck, 1990). These bioassays are mainly based on two concepts: Easily assimilable organic carbon (AOC) measures the growth of a bacterial inoculum in response to the amount of nutrient in the water, and biodegradable dissolved organic carbon (BDOC) measures the fraction of DOC assimilated and mineralized by heterotrophic microorganisms (Volk and LeChevallier, 2002). Although AOC and BDOC are useful surrogates for BOM, each suffers from limitations (Huck, 1990; Kaplan et al., 1994).

Assimilable Organic Carbon (AOC):

AOC typically comprises just a small fraction (0.1– 9.0%) of the TOC (van der Kooij, 1990). AOC method uses the metabolic diversity of three bacterial strains to degrade a very broad spectrum of organic substrates usually occurring in drinking water.

The inoculum is a mixture of pure bacterial strains cultivated under laboratory conditions (such as *Pseudomonas fluorescens P17* and *Spirillum NOX*). Bacterial growth is monitored in the water samples by measuring the colony counts, adenosine triphosphate measurements and turbidity.

AOC is calculated as the sum of the product of viable counts for each strain and the inverse of the yield of the respective strain on acetate. It is expressed as μg acetate-C equivalents per L, i.e.,

$$\text{AOC} = \frac{N_{P17}}{Y_{P17}} + \frac{N_{NOX}}{Y_{NOX}} \quad (2.2)$$

N_{P17} and N_{NOX} are the bacterial concentrations and Y_{P17} and Y_{NOX} are the yield coefficients for P₁₇ and NOX respectively.

Biodegradable Dissolved Organic Carbon (BDOC)

In contrast to the AOC method, the measurement of BDOC aims at the determination of organic carbon concentrations that can be removed from water. Thus, it is not the amount of biomass formed in the test, which is determined, but the decrease in dissolved organic carbon concentration.

In the procedure of original BDOC measurement developed by Servais et al. (1987), the sample is filter sterilized (by filtering through 0.45 μm filter) and then reinoculated with part of the sample that was filtered through 2 μm pore size for the removal of particle and the protozoa. Incubation at 20°C in the dark is carried out for a period of up to 30 days. Carbon utilization is monitored by regularly measuring the dissolved organic matter concentration. BDOC is calculated from the difference between the initial concentration and the plateau at minimum (DOC may increase slightly after a certain time as a result of bacterial lysis).

As this method requires relatively long incubation times a newer BDOC method with sessile bacteria, i.e., an increased bacterial inoculum was developed by Joret et al.

(1988). The inoculum usually consists of sand taken from from rapid filters in a drinking water treatment plant which was washed until no more DOC washout could be observed.

In another modification of the BDOC method, the sample is circulated through a bed of sintered glass beads with sessile bacteria (Frias et al., 1992).

Using BDOC as a surrogate for BOM, Servais and colleagues (1993) have proposed a maximum BDOC concentration of about 0.15 mg/L in order to consider the water as biologically stable, i.e. water which does not support the growth of microorganisms to a significant extent in the water distribution system (Rittmann and Snoeyink, 1984). However, the maximum allowable BOM concentration entering the distribution system is highly site specific and depends on numerous physical and chemical parameters of the water and the distribution system. In the absence of better information, many engineers have chosen the reduction of post ozonation BDOC levels to their pre-treatment levels as a treatment goal for BOM reduction in biofilters (Reckhow et al., 1993).

2.1.5. NOM Removal

The presence of NOM in drinking water is problematic due to the formation of trihalomethanes (THMs) and other halogenated compounds during disinfection with chlorine. Many of these disinfection byproducts (DBPs) are either carcinogenic or potentially carcinogenic and their presence in drinking water is being increasingly regulated by USEPA (Pontius, 1999). The maximum allowable THM concentration according to USEPA is 80 µg/L, while this limit is 100 µg/L in European Union Standards. It is expected these limits will be lowered to 50 or even 20 µg/L in future. Currently, THMs are not being regulated by Turkish Standards (TSE). However, as a country aiming at joining the European Union and having high TOC concentrations in water resources, Turkey will be dealing with regulating these limits in the near future. Since conventional processes, such as coagulation, may not meet current and future requirements for the control of disinfection by-products, alternative treatment technologies must be investigated (Yavich, 2004).

Potential treatment methods investigated decreasing both carcinogenic and mutagenic activity of treated waters include biological processes such as slow sand filtration, fluidized beds, river bank and dune filtration, biological active filters, biological activated carbon (BAC), and packed-bed reactors (Dalmacija et al., 1992). Reported removal of DOC by the aforementioned biological methods varies widely, from 5 to 90% depending on specific systems and environmental conditions. In addition, the majority of these processes showed significant decreases in AOC and DBP potential formation, both specific indicators of drinking water quality (Carlson and Silverstein, 1998).

Some other water treatment methods, including activated carbon adsorption and enhanced chemical coagulation, have been shown to remove NOM to varying degrees; however, these methods have associated costs- for example, relatively high capital costs for activated carbon process and disposal of excess waste sludge from enhanced coagulation (Carlson and Silverstein, 1997).

Biological treatment for NOM has several advantages (Carlson and Silverstein, 1997):

- No/few harmful compounds produced.
- Few residuals (excess biomass being removed during filter backwashing) which are easier to dispose of than many chemical water treatment sludges
- Less costly process equipment than activated carbon adsorption process
- Efficient removal of biodegradable organics (i.e. precursors of DBPs)

In contrast, it has several limitations;

- Adaptation of biomass is required, especially regarding poorly biodegradables.
- Vulnerability to fluctuations and other unfavorable conditions.
- No removal of non – biodegradables. (i.e. many organic micropollutants)

2.2. Granular Activated Carbon

2.2.1. Activated Carbon

Activated carbons are a class of carbonaceous materials which, depending upon the details of their preparation technique, exhibit a higher degree of porosity, an extensive internal surface area, and widely varied pore size distribution and surface chemistry (Moore, 2000). On an atomic scale, activated carbons are composed of hexagonally arranged carbon atoms in a short-ranged layered structure that is similar to that of graphite (Byrne and Marsh, 1995). These so-called graphene layers are stacked only approximately parallel to each other over distances of just a few nanometers. Accordingly, the space that makes up the volume of smaller pores (i.e. micropores) in GAC is slit-like because of imperfect, roughly parallel alignment of graphene layers.

The six-ring C atoms in basal planes show a low reactivity. However, C atoms at the edges of the basal planes and in the cross-links are much more reactive. Here, a range of C surface oxides can be created, e.g. by reaction with the molecular oxygen (Norit Carbon Corporation, 2002). In potable water practice, this relates to the phenomenon of oxygen uptake during start up of a fresh GAC filter. GAC's tendency to chemisorb oxygen is higher compared with any other species in water (Moore, 2000).

The adsorptive capacity of activated carbon is due to its extensive internal surface area and porosity (Derbyshire et al., 1995), in addition to the chemical nature of its surface. Indeed, the distribution and sizes of the pores found in an activated carbon play an important role in the adsorption process. Accordingly, pore sizes have been characterized by International Union of Pure and Applied Chemistry (IUPAC) (Sing, 1985) into three categories as follows: micropores ($<20\text{\AA}$), mesopores ($20\text{-}500\text{\AA}$), and macropores ($>500\text{\AA}$). The electron microscope photos in Figure 2.2 illustrate the extreme difference in the diameter of the pores. The macropores are clearly visible at all magnifications, while even at the greatest magnification (1 micron per cm) micropores are difficult to see.

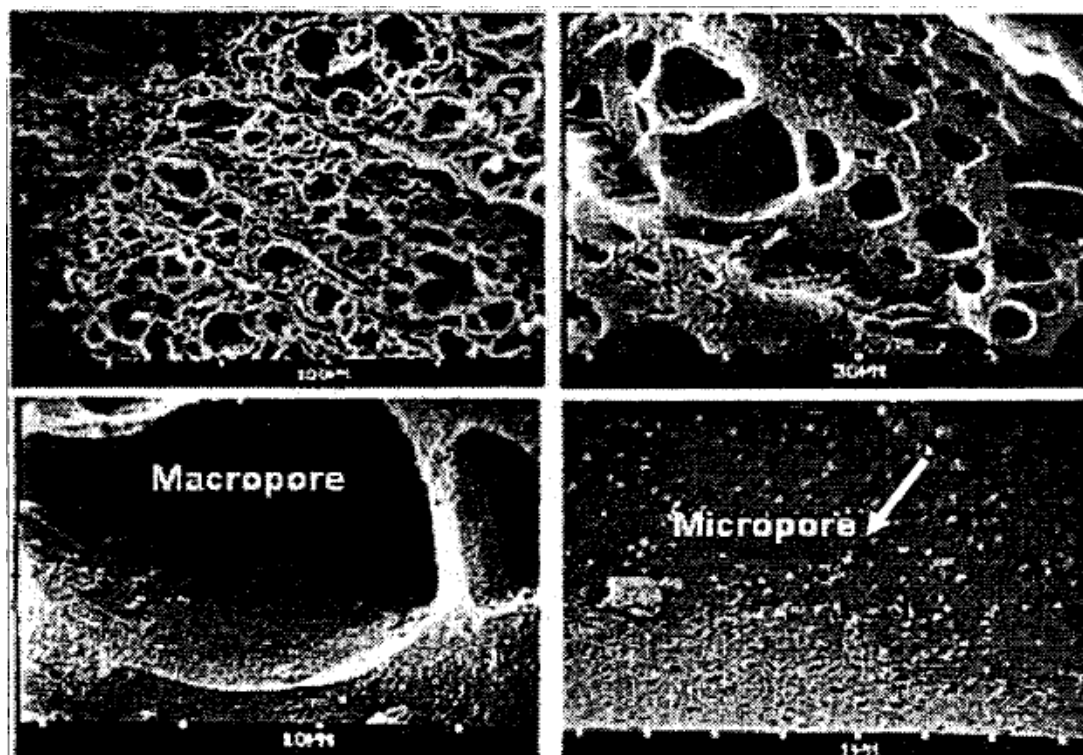


Figure 2.2 Electron microscope photos of a GAC particle (Sontheimer et al., 1988)

Micropores typically contribute most to the extensive surface area of activated carbons, and they have been correlated to the removal of small organic compounds from solution. In contrast, mesopores are generally important for adsorption of larger molecules (Derbyshire et al., 1995), which might not otherwise fit into micropores. The macropores are frequently considered less important for adsorption of organics during water treatment. Instead, they are thought to function as feeder pores for the transport of adsorbate molecules into the mesopores and micropores. Generally, a large volume of micropores is related to a high specific surface area and proficient removal of small molecules (Snoeyink, 1990). However, for water treatment applications, mesopores can also be important (Rodriguez-Reinoso, 1997). This is because many NOM molecules are simply too large to fit into the micropores.

2.2.2. Base Materials

GAC can be manufactured from any material that contains a large fraction of carbon. Most widely applied base materials are coal, wood, peat and coconut. On a limited scale GAC is produced from feed stocks like olive stones, palm kernel shells and pitch. Depending on the production process applied, other additives like binder are needed.

Table 2.2 shows the main GAC product families applied in potable water treatment. These products represent over 90 % of the total usage which is installed in potable water treatment plants worldwide (Norit Carbon Corporation, 2002).

Table 2.2 Main GAC product families in potable water treatment

Base Material	Coal	Peat	Wood	Coconut
Shape	Irregular	Extruded	Irregular	Irregular
Activation Process	Steam	Steam	Chemical	Steam

2.2.3. Activation

During activation, the internal porosity is created in the carbonaceous base material. Focused on GAC products used in potable water treatment, two different processes are applied in dedicated kilns:

1. Steam Activation: Steam being used as oxidant at temperatures in the range 800-1000°C.
2. Chemical Activation: Controlled carbonization in the presence of phosphoric acid at temperatures in the range of 500-700°C.

2.2.4. Surface Chemistry of Activated Carbon

Both chemical and physical factors are involved in the adsorption of target contaminants by activated carbons. Some important variables in the process are molecular structure of the contaminant, surface chemistry of the activated carbon, solution chemistry,

temperature and pH (Sontheimer et al., 1988; Morris and Newcombe, 1993; Newcombe, 1994). GAC contains some non carbon elements, usually from 5 – 20 % by weight (Sontheimer et al., 1988). These non carbon elements are mainly metal and surface bound oxygen (Terzyk, 2001). These surface elements are usually a function of the source material for the GAC as well as the activation process. For example, if the GAC was chemically activated, residual amounts of the activating agent will be integrated into the carbon structure. Surface oxide functional groups such as carboxylic, hydroxyl, carbonyl, lactone and carboxylic acid are believed to occur at the crosslinks and along the edges of crystalline planes (Sontheimer et al., 1988).

During the adsorption of NOM onto GAC, the chemistry of the NOM and that of the carbon surface can interact with each other. A negatively charged carbon surface can repel a negatively charged organic molecule, while a positive surface can enhance the attraction of negatively charged organics. Carbon functional groups can interact with NOM or the functional groups in NOM.

Perhaps the most commonly examined feature of surface chemistry is the point of zero charge (pH_{PZC}), which is the pH at which GAC surface carries a net charge of zero. Accordingly, for solution pH values greater than pH_{PZC} , the carbon carries a net negative surface charge; while for pH values below pH_{PZC} the carbon carries a net positive surface charge. The pH_{PZC} of an activated carbon can give an indication of the role that electrostatics might play during adsorption.

2.2.5. Reversible versus Irreversible Adsorption

Reversibility of adsorption is especially important in biological systems where bioregeneration is considered. Irreversible adsorption can be due to chemisorption between an adsorbate and the GAC surface, or because of chemical reactions that are catalyzed by GAC surface (Yonge et al., 1985). Physical adsorption, which is generally reversible, occurs when weaker van der Waals forces or charge transfer complexes are formed between the adsorbate and the adsorbent. In contrast, chemisorption involves interactions between the functional groups on the carbon surface and the adsorbing molecules forming chemical bonds that are resistant to desorption. Strong sharing of electrons or surface-

catalyzed chemical reactions may explain many instances of irreversible adsorption and govern the extent of irreversibility.

The extent of irreversible adsorption is a function of several factors and difficult to predict. Most notably, irreversible adsorption is influenced by the strength of the bonding between adsorbed NOM molecules and the adsorbent surface (Yonge et al., 1985). At low surface loading, a higher fraction of the sorbed material will be irreversibly adsorbed due to these high energy surface reactions. Properties of the adsorbate and the GAC surface, as well as the solution chemistry, all affect the chemical bonding and irreversible adsorption. (Grant and King, 1990). Availability of oxygen can also influence the degree of reaction on GAC surfaces, especially for phenolic compounds. Oxidative polymerization of phenolic compounds onto activated carbon due to the presence of oxygen can also be the reason for irreversible adsorption (Jonge et al., 1996; Vinitnantharat et al, 2001)

2.2.6. NOM Adsorption

Granular activated carbon (GAC) is widely applied in the production of potable water all over the world. Most organic components of water, including NOM, are readily adsorbed onto activated carbon. The extent of adsorption depends on a number of factors such as charge, size and polarity of the adsorbate, and the relationship between the adsorbate structure and activated carbon surface (Summers and Roberts, 1988).

2.2.6.1. Mass Transfer Zone and Breakthrough Curves for Packed Bed Reactors. The region of an adsorption column in which adsorption is taking place, the mass transfer zone (MTZ), is shown in Figure 2.3a. The activated carbon behind the MTZ has been completely saturated with adsorbate at $C_e = C_0$, and the amount adsorbed per unit mass of GAC is $(q_e)_0$. The activated carbon in front of the MTZ has not been exposed to adsorbate, so the solution concentration and adsorbed concentration are both zero. Within the MTZ, the degree of saturation with adsorbate varies from 100 percent ($q = [q_e]_0$) to zero. The length of the MTZ, L_{MTZ} , depends upon the rate of adsorption and the solution flow rate. Anything that causes a higher rate of adsorption, such as a smaller carbon particle size, higher temperature, a larger diffusion coefficient of adsorbate, and/or greater strength of adsorption of adsorbate (i.e., a larger Freundlich K value), will decrease the length of the

MTZ. In some circumstances, L_{MTZ} will be reduced sufficiently that it can be assumed to be zero, yielding the ideal plug-flow behavior, as shown in Figure 2.3b. If LMTZ is negligible, analysis of the adsorption process is greatly simplified. The breakthrough concentration C_B for a column is defined as the maximum acceptable effluent concentration. When the effluent concentration reaches this value, the GAC must be replaced. The critical depth of a column $L_{critical}$ is the depth that leads to the immediate appearance of an effluent concentration equal to C_B when the column is started up. For the situation in which C_B is defined as the minimum detectable concentration, the critical depth of an activated carbon column is equal to the length of the MTZ. The length of the MTZ is fixed for a given set of conditions, but $L_{critical}$ varies with C_B . The critical depth, the flow rate Q , and the area of the column A , can be used to calculate the minimum empty bed contact time (EBCT) (Snoeyink and Summers, 1999).

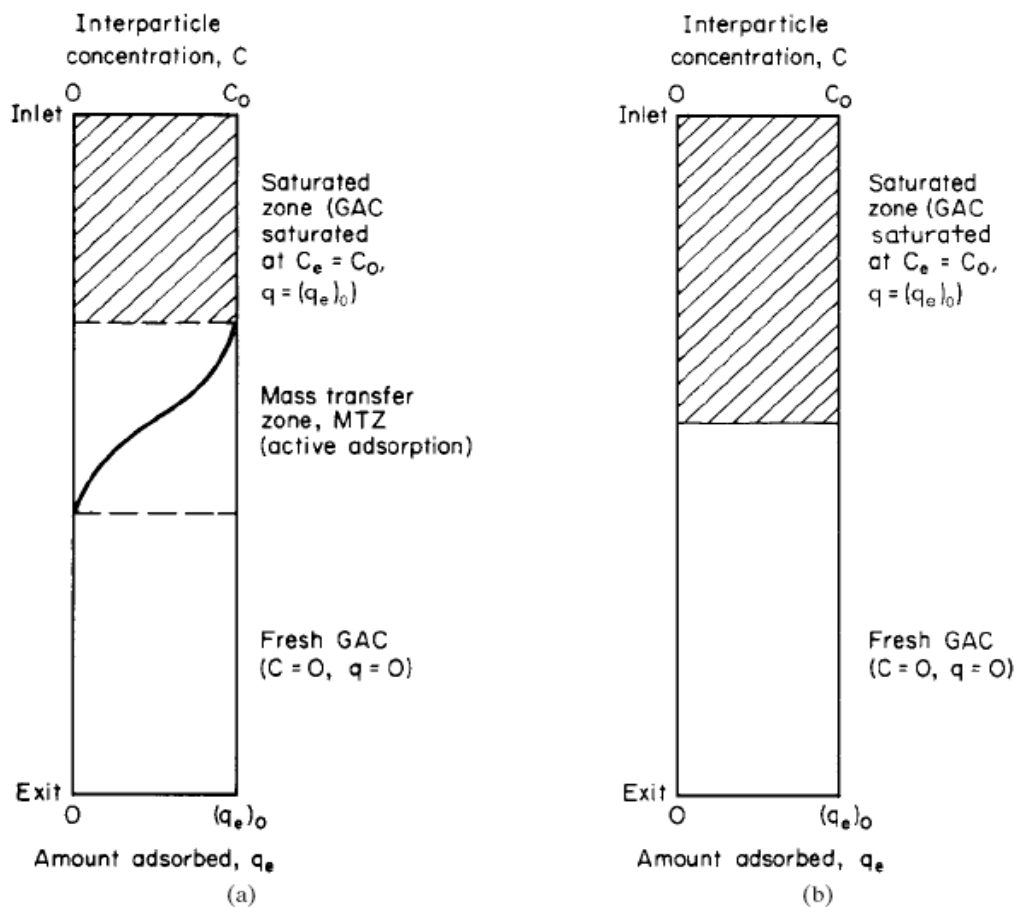


Figure 2.3 Adsorption column (a) Column with MTZ (b) Column without MTZ (Snoeyink and Summers, 1999)

The breakthrough curve is a plot of the column effluent concentration as a function of either the volume treated, the time of treatment, or the number of bed volumes (BV) treated ($BV = V_B/V$, where V_B is the volume treated). The number of bed volumes is a particularly useful parameter because the data from columns of different sizes and with different flow rates are normalized. A breakthrough curve for a single adsorbable compound is shown in Figure 2.4. The shape of the curve is affected by the same factors that affect the length of the MTZ, and in the same way. Anything that causes the rate of adsorption to increase will increase the sharpness of the curve, while increasing the flow rate will cause the curve to “spread out” over a larger volume of water treated. The breakthrough curve will be vertical if $L_{MTZ} = 0$, as shown in Figure 2.3b. As shown in Figure 2.4, the breakthrough capacity, defined as the mass of adsorbate removed by the adsorber at breakthrough, and the degree of column utilization, defined as the mass adsorbed at breakthrough/mass adsorbed at complete saturation at the influent concentration, both increase as the rate of adsorption increases (Scott and Summers, 1999).

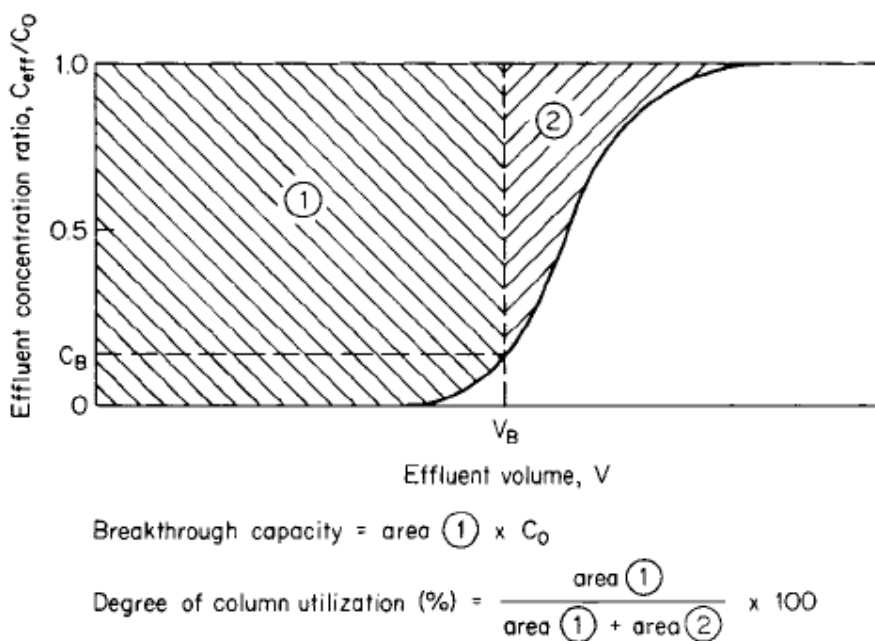


Figure 2.4 Adsorption column breakthrough curve (Snoeyink and Summers, 1999)

Breakthrough curves are strongly affected by the presence of nonadsorbable compounds, the biodegradation of compounds in a biologically active column, slow adsorption of a fraction of the molecules present, and the critical depth of the column

relative to the length of the column. Immediate breakthrough of adsorbable compounds occurs if the L_{MTZ} is greater than the activated carbon bed depth (compare curves A and B in Figure 2.5). Nonadsorbable compounds immediately appear in the column effluent, even when the carbon depth is greater than the L_{MTZ} (compare curves B and C in Figure 2.5). Removal of adsorbable, biodegradable compounds by microbiological degradation in a column results in continual removal, even after the carbon is saturated with adsorbable compounds (see curve D in Figure 2.5). If a fraction of compounds adsorbs slowly, the upper part of the breakthrough curve will be similar to that produced by biodegradation but will slowly approach $C_{eff}/C_0 = 1$.

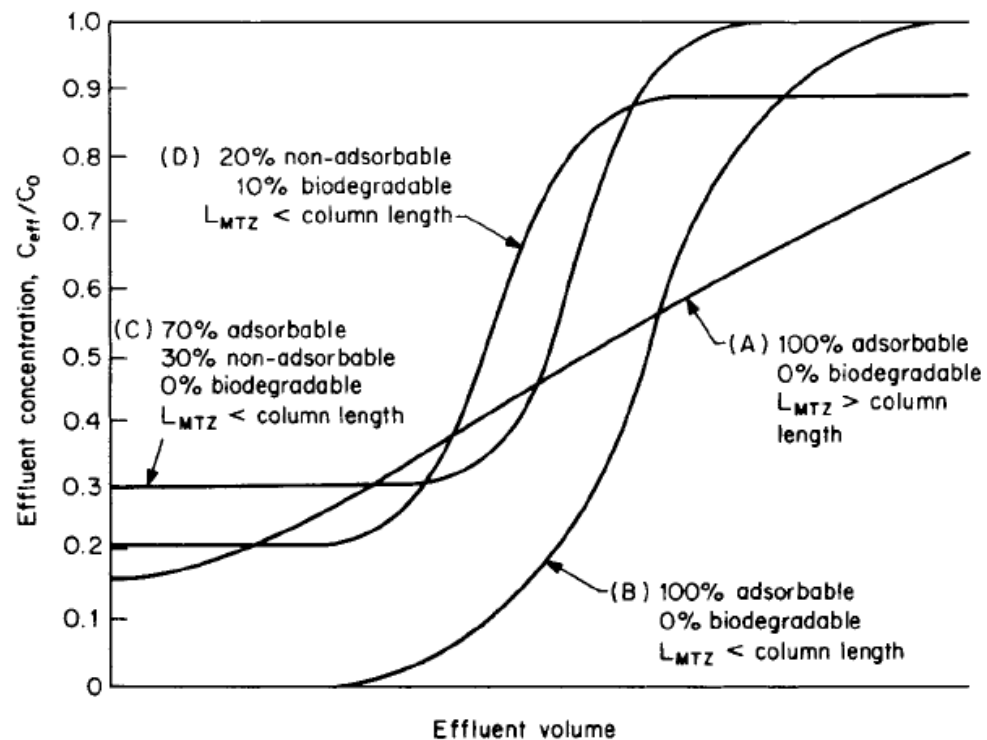


Figure 2.5 Effect of biodegradation and presence of nonadsorbable compounds on the shapes of breakthrough curves (Snoeyink and Summers, 1999)

2.3. Biological Activated Carbon

2.3.1. Microbial Attachment to Surfaces

Bacteria and other microorganisms are naturally occurring in water supplies. The number of bacteria leaving a sand filter, which usually precedes treatment with GAC, is very low (less than 100 viable cells per milliliter of drinking water). This number is greatly increased when bacteria present in the influent to GAC reactor attach to the GAC surface.

Organisms preferentially attach to a surface due to a number of reasons (Characklis, 1981):

1. Microorganisms may utilize more readily nutrients concentrated at surfaces than dissolved nutrients.
2. Extracellular enzymes diffuse away more slowly in the presence of a surface thus catalyzing reaction of organics more efficiently
3. Surfaces may remove substances inhibiting bacterial growth
4. Biopolymer production may adsorb nutrients and concentrate extracellular enzymes resulting in enhanced growth rates

GAC is home to an ecosystem of bacteria and protozoans due to its well-suited surface and macropores. The rough, pitted surface of GAC provides shelter from fluid shear forces; enriches substrates, nutrients and oxygen concentrations; and contains functional groups that enhance the attachment of microorganisms (Weber et al., 1978; Voice et al., 1992). In many cases, it has been shown that use of GAC media results in more bioactivity as compared to other filtration media, including anthracite and sand (Urfer et al., 1997). The key difference between GAC and other potential carriers of biomass are its adsorptive properties.

Using Environmental SEM (ESEM) analyses Aktaş and Çeçen (2006b) showed that microorganisms were attached both to the external surface and to the internal cavities of PAC particles. Similarly, using SEM analyses, Vuoriranta and Remo (1994) showed that bacteria (filamentous and rod-shaped) were present only inside the holes and pores, but not on the surfaces of GAC particles in a fluidized bed reactor. Walker and Weatherley (1998)

showed that bacteria successfully colonized the macropore structure of GAC. Another report (Abu-Salah et al., 1996) using SEM analysis showed that bacteria attached on both the internal cavities and outer surface of PAC particles.

2.3.2. Microorganisms in Biofilms of Biological Filters

The low concentrations and multiple components of BOM in drinking water favor the growth of oligotrophic, heterotrophic bacteria known as oligotrophs. Oligotrophs are characterized as being able to survive and metabolically function when the substrate concentration is very low (Atlas and Bartha, 2000). If there are substantially high levels of ammonia in the source water, autotrophic bacteria (nitrifiers) may be the dominant bacteria. Bacteria are the dominant microorganisms in the microbial ecosystems of drinking water filters. However, different studies have shown that higher organisms, e.g., heterotrophic protozoans (Servais et al., 1991), annelids (Beaudet et al., 1996), metazoa (Uhl, 2000a) and moulds and yeast like fungi (Grabinska et al., 2004) are present in biofilters.

Based on several literature sources on biomass levels in biofilters (reported as phospholipids), Urfer (1998) provided an estimation of the number of bacteria in the top part of the filters. The biomass ranged between 10^9 to 10^{10} cells per cm^3 filter media, using conversion factors from Findlay et al. (1989). These numbers are about an order of magnitude higher than those reported by Servais et al. (1991) using different methods. The typical cell concentration in the bulk liquid of biofilters was reported in the range of 10^4 to 10^5 per mL (Servais et al., 1991; Lu and Huck, 1993). Activated carbon filters have much higher densities in bacteria than that of sand filters (Uhl, 2000a).

Uhl (2000a) reported that in drinking water treatment a decrease can usually be observed in suspended bacteria concentration from the influent to the effluent of biofilters, if the influents are not directly disinfected.

Increases in bacterial concentrations are mainly restricted to initial phases of operation of such filters of 30-150 days. The reasons are not completely clear, but it is assumed that inorganic and organic nutrient sources for phosphate and/or nitrogen may be

released from the solid media during early operation, thus increasing the yield of heterotrophic bacteria on organic substrates (Uhl, 2000a).

Up to the present, the real microbial community was not investigated in detail in biofilters of drinking water treatment. The identification of microorganisms in drinking water biofilters is limited to cultivation dependent methods. Only a small percentage of the microorganisms in the natural environment are cultivable (Amann et al., 1995), and this in turn has limited the ability of researchers to study the general composition of microbial communities. Therefore, significant bias can enter our understanding of microbial communities in the biofilters when using cultivation-dependent methods. It has long been known that the direct visualization of microorganisms in a natural sample by staining and microscopy yields a population count one to two orders of magnitude higher than that measured by culturing from the same sample (Staley and Konopka, 1985; Amann et al., 1995). Molecular tools can fill the lacking information about the microbial communities as well as their populations in the drinking water biofilters.

2.3.3. Biofilms in Drinking Water Biofilters

In biologically active filters, biodegradable electron donor substrates are oxidized through redox reactions catalyzed by bacterial enzymes. Dissolved oxygen usually serves as the electron acceptor for the biological oxidation of substrate in biofilters. The most relevant electron donors in drinking water are BOM, NH_4^+ , Fe^{2+} , Mn^{2+} , NO_2^- , dissolved H_2 and several reduced species of sulphur (Rittmann and Huck, 1989). Different bacteria are required for these donor substrates. BOM degradation uses BOM as both a carbon source and electron donor. In drinking water biofilters, the dissolved oxygen concentrations are often 1 to 2 orders of magnitude higher than BOM. Therefore, oxygen is not normally the bioreaction rate limiting factor in drinking water biofilters (Liu, 2001).

In addition to process considerations, NOM is generally thought to have a significant fraction of hard-to-degrade organic compounds, which may require complex sequences of specialized enzymes to reduce molecules to a size which can be transported across bacterial membranes. Combining biofilm morphology with the recalcitrance of NOM molecules has led to a proposed model of biofilm NOM removal. Specifically, a

recalcitrant NOM molecule that is removed from water may be first sorbed to a biofilm allowing a longer detention time within the biofilm to accommodate slow biodegradation. Thus, the factors which affect biosorption are particularly important in determining the effectiveness of biological processes for the removal of NOM (Liu, 2001).

Biofilm formation is the net result of a number of processes including adsorption, desorption, attachment, microbial growth and endogenous decay (Characklis and Marshall, 1990). Attachment is usually considered to be important during the initial development period and negligible during the dynamic steady-state period (Liu, 2001).

Biofilms are generally considered to be composed of two major components (Characklis and Marshall, 1990):

- a) Microbial cells.
- b) Extracellular Polymeric Substances (EPS) which are synthesized by attached bacteria.

Thus, the biofilm can be considered as an organic polymer gel with living microorganisms trapped within it. The physical and chemical properties of biofilms produce a unique structure similar to a porous gel containing 90-95% water. The EPS matrix contains many chemically active sites which have been shown to complex inorganic cations as well as sorb organic molecules (Characklis and Marshall, 1990). Until recently, mature biofilms are thought to be relatively uniform in thickness. However, over the past few years increased resolution in analytical techniques has changed the concept of a relatively homogenous biofilm layer. New research indicates that biofilm contains interstitial voids, channels and cell clusters which complicate the water-biofilm interface as well as internal mass transport in the biofilm (de Beer et al., 1993). Overall, it appears that the contact between biofilm and water is much greater than had been previously assumed, increasing the importance of both the chemical interactions between contaminants in water and biofilm and the transport of water contaminants through biofilm pores and channels (Carlson and Silverstein, 1998).

Because EPS is a significant component of biofilm, the chemical nature of EPS significantly affects many interactions between dissolved contaminants and the biofilm.

The main structural monomers of biofilm EPS polymers include glucose, galactose, mannose, galacturonic acid and glucuronic acid (Characli and Marshall, 1990). EPS also contains pyruvate, uronic acids and neutral sugars which dramatically affect overall biofilm characteristics (Morgan et al., 1990). The dominant functional groups of sugar-acid residues in EPS are carboxyl and hydroxyl acids, which are ionized at neutral pH values producing negative biofilm surface charge at conditions found in most environments (Morgan et al., 1990). The net negative surface charge of biofilms is likely to influence sorption and transport of charged aqueous contaminants, particularly decreasing diffusion of negatively charged NOM molecules within the biofilm, compared with neutral or positively-charged molecules which would have more favorable electrostatic interaction with the negatively charged EPS (Carlson and Silverstein, 1998).

Substrate (nutrients) to be used by microorganisms within the biofilm must be transported by diffusion across the stagnant liquid layer into the biofilm matrix, since the only source of the substrate is the bulk liquid. Substrate utilization by the biofilm creates a substrate concentration gradient in the biofilm and a driving force for the nutrient diffusion into the biofilm (Figure 2.6). Biodegradable organics, suspended cells and other particulates (not shown), dissolved oxygen, and other dissolved nutrients are pumped into the top of the filter and flow down through the filter bed. Biomass accumulates on the filter media due to deposition and growth as water containing bacteria and BOM flows through the filter. Biodegradation of substrate and growth of cells also occurs in the bulk liquid.

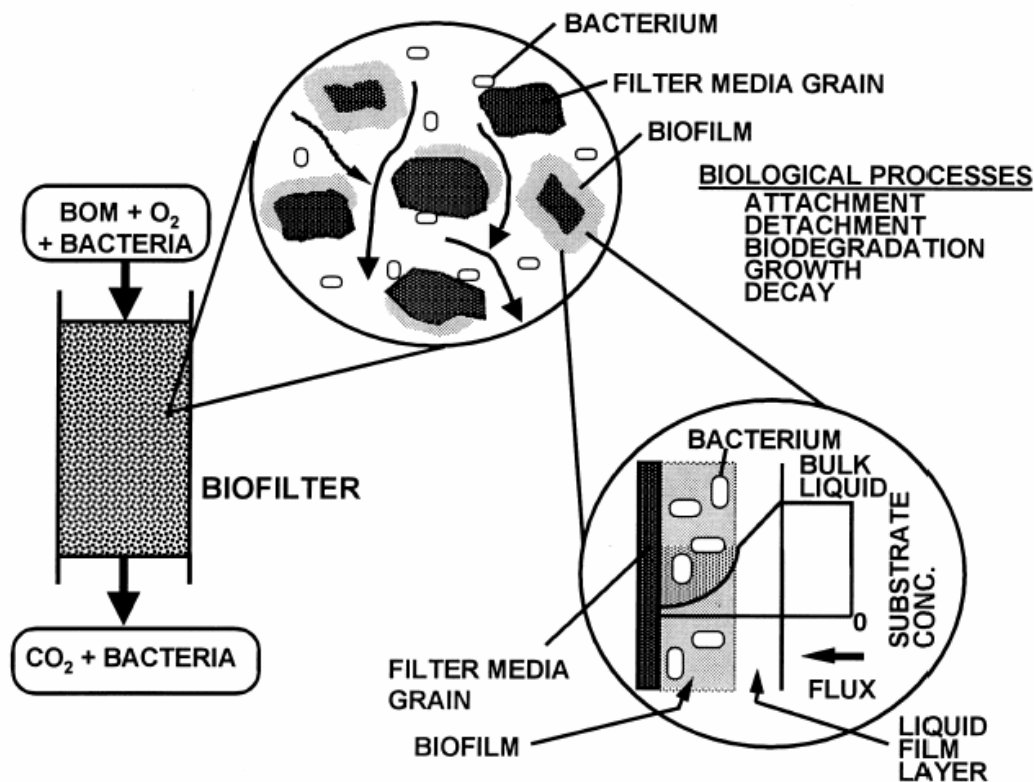


Figure 2.6 Schematic diagram that illustrates the processes occurring in a biofilter (Hozalski and Bouwer, 2000)

It is shown in literature that, under conditions of potable water treatment, bio-activity will develop on any GAC grade. In practice, differences regarding bio-activity between GAC grades are limited. Wood based GAC initially shows an increased nitrification activity at low temperatures, however, an aging effect was observed after several years (Andersson et al., 2001). Effect of different GAC types on bioactivity should be investigated and well-understood in order to choose the best type in terms of biodegradation. More detailed knowledge about the interactions between treatment conditions and biodegradation in GAC filters may lead to a more efficient use of GAC filters in water treatment.

2.3.4. Ozone – Biological Activated Carbon System

Ozonation-biological activated carbon treatment is one of the most promising processes among advanced drinking water treatment processes. The GAC, which has

bioactivity on its surface and removes significant amounts of DOC by biodegradation is especially called biological activated carbon (BAC) (Nishijima and Speitel Jr., 2004). Because biofiltration usually is not capable of removing biorefractory substances, pre-oxidation processes should be applied. Ozone is an oxidant which is frequently used for this purpose. Combination of ozonation with biological treatment has the advantage on reduction of biological regrowth potential over other advanced drinking water treatment processes, because biological treatment can remove biodegradable organic matter selectively. Ozonation converts nonbiodegradable organic matter to biodegradable organic carbon (BDOC) by breaking the structure of NOM and enhancing the transformation of higher molecular weight compounds into lower molecular weight compounds, such as carboxylic acids (Win et al., 2000).

The main advantage of BAC filtration in water treatment is to remove the biodegradable compounds which comprise the most undesirable fraction of organic matter (Servais et al., 1992). Moreover, a recalcitrant NOM molecule that is removed from water may first be sorbed to the biofilm, allowing a longer detention time within the biofilm to accommodate slow biodegradation (Carlson and Silverstein, 1998).

However, excess biomass can cause clogging of BAC filters and high head losses. On the other hand, a weak biofilm does not efficiently remove chemical oxygen demand (COD) and total organic carbon (TOC) (Scholz and Martin, 1997).

A BAC filter works as a bioreactor in which two parallel processes take place: adsorption on activated carbon and biodegradation. During the biodegradation process the organic compounds (both previously adsorbed and dissolved in water) are metabolized by microorganisms (Chudyk and Snoeyink, 1984; Servais et al., 1992). The phenomenon of metabolization of adsorbed chemicals is known as bioregeneration. With bioregeneration, the lifetime of a BAC filter can be extended and the activated carbon does not require frequent expensive regeneration. Some authors suggest that biosorption is another important mechanism of removal of natural organic matter by microorganisms attached to activated carbon. Biosorption is defined as removal of dissolved and colloidal organic compounds, metals and inorganic compounds from an aqueous solution by sorption into or onto biofilms or bacterial flocs (Carlson and Silverstein, 1997).

2.3.5. Effects of Ozonation on Chemical Properties of NOM

Ozone reacts with NOM either through direct reactions, involving molecular ozone, or by indirect reactions involving radical oxidation species produced from ozone decomposition. Both types of reactions occur during typical water treatment and the extent of each type depends on the conditions and nature of the water quality.

Ozonation causes substantial structural changes to the humic substances which include; a strong and rapid decrease in color and UV-absorbance (254) due to a loss of aromaticity and depolymerization (Camel and Bermond, 1998); a small reduction in TOC (e.g., 10 % at 1 mg O₃/mg C); a slight decrease in the high apparent molecular weight fraction, and a slight increase in the smaller fractions; a significant increase of the carboxylic functions; formation of ozonation byproducts (Graham, 1999); conversion of humic into nonhumic material and increase in polarity (Nishijima and Speitel, 2004). These byproducts have been reported to be mainly aldehydes (formaldehyde, acetaldehyde, glyoxal, methylglyoxal) and carboxylic acids (formic, acetic, glyoxylic, pyruvic and ketomalonic acids) (Camel and Bermond, 1998). The shift of molecular distribution to lower values is important in enhancing the biodegradability of NOM because low molecular compounds are more easily transported across the cell membrane and are attacked by metabolic enzymes (Nishijima et al., 2004). UV absorbance at 254 represents the existence of unsaturated carbon bonds including aromatic compounds, which are generally recalcitrant for biodegradation, and decrease of UV absorbance results in the increase of biodegradability (Nishijima et al., 2004).

2.3.6. Effect of Ozonation on Adsorptive Properties of NOM

It is important to know the change of adsorbability in NOM by ozonation preceding GAC adsorption. Ozonation may have negative effect on GAC adsorption of NOM due to the increases in polarity and hydrophilicity and positive effect due to the decrease in molecular weight. Kim et al. (1997b), showed that ozonated NOM has lower adsorbability to GAC than NOM without ozonation. Benedek et al. (1979) showed the same result, however, they also showed that ozonated NOM after biostabilization has almost the same adsorbability as NOM without ozonation.

Nishijima and Speitel (2004) studied the adsorption and desorption characteristics of BDOC produced by ozonation. They found that BDOC produced by ozonation showed the same or lower adsorption capacity than non-BDOC after biodegradation. The adsorption rate of BDOC on GAC was lower than that of non-BDOC. BDOC produced by ozonation had low desorbability and majority of BDOC produced were not replaced by non-BDOC.

2.3.7. Factors Affecting Biological Performance

The removal rate of biodegradable organic matter is important to the design and operation of drinking water biofilters and the fate of nutrients available for bacterial growth in distribution systems.

2.3.7.1. Effect of Ozone Dose. It is well established that ozonation increases the fraction of natural organic matter (NOM) that is biodegradable. In many cases, the substantial increase in BOM upon ozonation may encourage bacterial growth in the distribution system, especially if ozonation is not followed by biofiltration (LeChevallier et al., 1996). In all but a few drinking water situations, carbon rather than nitrogen or phosphorus is the limiting substrate for bacterial growth. Thus, increase in BOM upon ozonation generally considerably enhances biological activity in filters following ozonation (DeWaters and Digiano, 1990). Often, biofiltration following ozonation can reduce BOM concentration to approximately preozonation levels (Urfer et al., 1997).

In their work Carlson and Amy (1997) observed that $\text{BDOC}_{\text{rapid}}$ increased with an ozone dose up to approximately $1.0 \text{ mg O}_3 / \text{mg DOC}$, at which point the concentration leveled out. At this optimum dose, the maximum fraction BOM was converted to filter-removable BDOC. Increasing the ozone dose further will only result in release of more BDOC to the distribution system, an increase in the operating cost.

Similarly, Yavich et al. (2004) observed that most pronounced increase in biodegradable organic matter was seen at an ozone dose of $0.5 \text{ mg O}_3 / \text{mg C}$ for Huron River water. An increase in the dose to $1.0 \text{ mg O}_3 / \text{mg DOC}$ resulted in only a slight increase in BDOC concentration.

2.3.7.2. Effect of Filter Media. The selection of filter media, often a central question when biofiltration is used, is important because of its major cost implications (Urfer et al., 1997). Experimental investigations have examined both adsorptive medium (GAC) and nonadsorptive media (anthracite and sand) for biological BOM removal. Little biogrowth seems to occur in the GAC micropores because their small diameter (1-100 nm) does not allow the penetration of bacteria, which typically have a diameter >200 nm. Consequently, the specific surface area (unit surface per unit volume of filter) available for biomass attachment might be higher in a sand filter compared with a GAC filter, because the effective size of the sand is usually smaller than GAC. However, the macroporous structure and irregular surface of GAC offer suitable bacterial attachment sites, providing increased protection from shear stress as explained in Section 2.3.2. In addition, GAC has the ability to adsorb and remove potentially inhibitory chemicals and to adsorb and retain slowly biodegradable components that can be biodegraded by attached bacteria, leading to the continuous bioregeneration of the GAC (Chang and Rittmann, 1987; Aktaş and Çeçen, 2006a, 2006b).

Most GAC used in water treatment plants today is made from various kinds of natural coal, which are both inexpensive and readily available. In the past 15 years, however, wood-based GAC has emerged as a viable media alternative and has been used successfully in pilot and full-scale filter applications in the United States and Europe (Grens and Werth, 2001). In general, GAC produced from soft or hard wood will produce a soft-textured activated carbon, whereas a soft or hard coal will produce a medium-hard or hard-textured activated carbon product. The relative hardness of filter grain is considered to be essential in assessing the long-term durability (or abrasion resistance) of the media (Cleasby, 1990). GAC durability is important because of its impact on filtration costs

LeChevallier et al. (1992) compared biological GAC-sand and anthracite-sand filters in parallel using preozonation. TOC removals averaged 51 % for GAC-sand and 26 % for anthracite-sand with raw water TOC of approximately 3 mg/L. This major difference in the effluent TOC concentrations suggests that part of the removal of TOC might be attributable to adsorption on GAC surface.

A pilot study conducted by Krasner et al. (1993) showed that GAC-sand filters established aldehyde removal sooner and were more resistant to temporary perturbations such as intermittent chlorination and out-of service periods. Additionally, GAC-sand outperformed anthracite-sand in removing, glyoxal, a less readily biodegradable aldehyde. This study also showed that a carbon based GAC and a wood based GAC yielded similar biological removals of formaldehyde and glyoxal.

Merlet et al. (1992) compared a wood-based GAC with a macroporous structure and a common coal-based GAC with a more microporous structure at full scale. The concentration profiles of both DOC and BDOC were not different in the two GAC filters with an empty bed contact time (EBCT) of 25 minutes; ammonia removal, however, was significantly improved in the wood-based GAC.

Liu et al. (2001) suggested that GAC filters were able to tolerate chlorinated backwash water much well than anthracite filters did, both at low and high temperatures.

2.3.7.3. Effect of Contact Time. A number of researchers have shown that contact time significantly influences BOM removal within biological filters (DeWaters and Digiano, 1990; Huck et al., 1994; Zhang and Huck, 1996). Contact time, usually expressed as empty bed contact time (EBCT), is therefore a key design and operating variable. Recently, modeling has provided additional justification for this experimentally observed finding. Zhang and Huck (1996) have introduced the concept of the dimensionless contact time, which incorporates EBCT, specific surface area of the medium, and parameters related to substrate biodegradability and diffusivity. A simplification of this – the normalized EBCT, equal to the product of EBCT and specific surface area- may represent a useful design parameter. In practice, either filter depth or hydraulic loading can be changed to increase the EBCT.

Several researchers have shown that the contact time and not the hydraulic loading is the key parameter for biological BOM removal and that for a given EBCT, BOM removal is independent of hydraulic loading in the range typically used in rapid filtration (Huck et al., 1997). This empirical finding suggests that external mass transfer may play a minor role in BOM removal under conditions typical for drinking water treatment because

for a given EBCT, the increase in flow velocity did not increase the rate of removal. Because influent BOM concentration and the amount of BOM removed were observed to be directly proportional, the removal of BOM can be approximated by a first order model (Huck et al., 1997). Consequently, increasing EBCT will improve removals but less than proportionally. Thus the incremental benefit of using very long contact times is likely small, which has been shown both theoretically and experimentally (Huck et al., 1997).

Carlson and Amy (1998) investigated the effect of hydraulic loading rate and EBCT on DOC removal under both nonsteady-state and steady-state biomass conditions using anthracite media. BOM formed during ozonation limited the removal of BDOC during biofiltration with two exceptions: nonsteady-state BOM loading conditions and inadequate EBCT (<2 min). Both of these conditions were limited by biomass formation. If the bed depth is too shallow or the hydraulic loading rate is too much, then the amount of biomass formed will be less than the potential biomass that could be formed, and the biofiltration process performance will be suboptimal.

Yavich et al. (2004) investigated the relationship between the ozone dosage and the minimum EBCT required for removing BDOC_{fast} (easily biodegradable BDOC). Studies with Lake Lansing have shown that increasing the ozone dose from 1.5 mg O₃ /mg DOC to 3 mg O₃ /mg DOC resulted in the increase in formation of BDOC_{fast}, hence decreased the EBCT_{min} from 17.3 to 15.4 minutes.

Hozalski et al. (1995) have reported data from a laboratory-scale investigation on biological treatment. Sand filters were fed with ozonated NOM cocktails (2-3.6 mg O₃/mg TOC), and the authors reported no significant differences in TOC removal between filters operated at 4, 10, and 20 min of EBCT. However, the operational mode of the biofilters in this study may not have simulated rapid filtration conditions: (1) the filters were not backwashed, possibly leading to a high amount of biomass attached to the media, (2) the O₃-to-TOC ratio was high, possibly leading to the formation of large amounts of easily biodegradable material, and (3) the hydraulic loading was about two orders of magnitude lower than is common in full-scale rapid filtration, resulting in low shear stress, which is favorable to the growth of a thick biofilm.

2.3.7.4. Effect of Backwashing. The success of biological filtration requires that the amount of biomass be carefully managed during the filtration cycle and that biomass losses during backwashing be controlled. Because biofilters accumulate both biological and nonbiological particles, the difference in the detachment of these groups of particles during backwashing will influence the optimization of backwash strategies for biofilters (Huck et al., 1997). Because a constant hydrodynamic force is exerted by the fluidized backwash water, the relative removals of nonbiological particles and bacteria depend on their adhesive strength with the media (Ahmad and Amirtharajah, 1998). Compared with hydrophilic colloids, hydrophobic colloids produce a deeper primary minimum. Consequently, bacteria attach more strongly to the GAC surface than clay particles do. This indicates that hydrophobic particles (bacteria) are more difficult to detach from surfaces than hydrophilic particles (Ahmad and Amirtharajah, 1998).

Although some treatment plants use nonchlorinated backwash water for their biofilters, others are operated with chlorinated backwash water either for every backwashing or intermittently. Therefore, it is important to understand how chlorinated backwash water affects BOM removal and the amount of biomass in filters.

Miltner et al. (1995) conducted a pilot plant study focusing on the effect of chlorine in the backwash water of anthracite-sand biofilters operated at an EBCT of 9.2 min. The authors reported that the biomass concentrations (measured as phospholipid) at the top of the filter were approximately one order of magnitude lower for the first filter compared with the second filter which is backwashed with nonchlorinated water.

With regard to the effect of chlorine in the backwash water of biofilters, the duration of backwashing procedure – i.e., the period of chlorine exposure (similar to the contact time concept for disinfection)- is likely a relevant factor, as is the chlorine concentration in the backwash water. Thus, vigorous backwashing for a short period of time might be preferable to a longer, less powerful backwashing procedure if the backwash water contains chlorine (Huck et al., 1997).

2.3.7.5. Effect of Temperature. Many drinking water sources experience seasonal temperature variations. Theoretically, BOM removal in biofilters would be expected to

increase at higher temperatures, because both microbial kinetics and mass transfer are more rapid. These effects, however, may be influenced by the media type.

Liu et al. (2001) reported that BOM removal patterns within the biofilters were related to temperature. However, the temperature's effect was more significant under unfavorable conditions (chlorine in backwash water, anthracite media, and refractory BOM components).

Moll et al. (1999) worked with bench-scale sand biofilters treating NOM isolated from surface water operated at parallel at 5, 20 and 35 °C to isolate the effect of temperature from other water quality and operational parameters, which also vary seasonally. The biofilter operated at 5°C achieved significantly lower removal of NOM and NOM fraction that reacts with disinfectants compared to the filters operated at 20 and 35 °C, which had similar performance levels.

Both studies presented data supporting others' results, which indicate that the amount of biomass is not the rate-limiting factor for the removal of BOM, under certain conditions.

2.3.7.6. Effect of Oxidants in Filter Influent. In some cases, oxidant residuals, e.g., ozone, hydrogen peroxide, chlorine and monochloramine may be present in biofilter influents, and their potential effects on BOM removal are of concern. In this regard, the filter media is important: GAC decomposes chlorine and other oxidants through redox reactions at the surface (Boere, 1991). Therefore, biological activity can be established in GAC filters even if the filter influent is chlorinated. However, chlorine in the influent of GAC filters can lead to a structural deterioration of GAC.

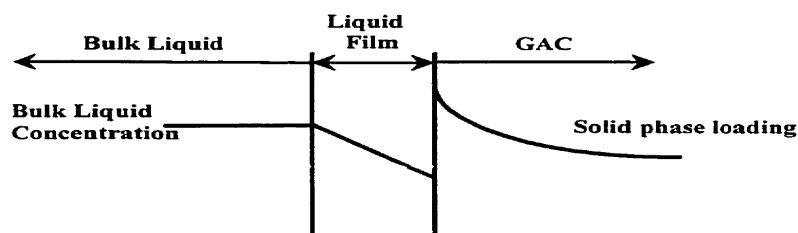
Weinberg et al. (1993) have observed that ozone residuals of 0.1-0.2mg/L inhibited bacterial development in pilot scale anthracite-sand filters and therefore reduced biofiltration performance.

2.3.8. Bioregeneration in BAC Columns

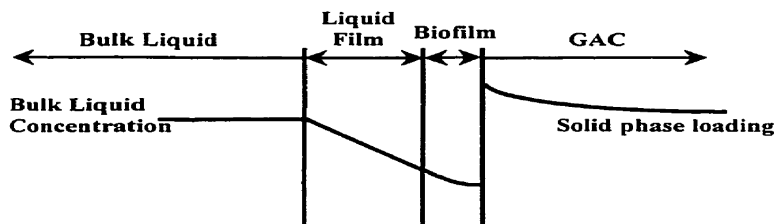
Bioregeneration is the renewal of GAC adsorption capacity as a result of desorption of sorbed contaminants and subsequent biodegradation. Bioregeneration can maintain adsorption capacity, prolong GAC service life, and treat spent GAC. GAC adsorbs toxic and slowly biodegradable contaminants and protects bacteria from fluid shear, allowing growth and acclimation of microorganisms (Bouwer and McCarthy, 1981). Concurrent biodegradation and adsorption provides more stable operation than either process operating independently, especially when influent concentrations suddenly increase (Voice et al., 1992). Bioregeneration allows recycling and reuse of GAC, and requires much less energy to destroy sorbed contaminants as compared to thermal regeneration (Kim and Pirbazari, 1989).

Bacteria in GAC columns can be detrimental to adsorber performance (Olmstead and Weber, 1991). The presence of a biofilm on GAC particles increases the mass transfer resistance during adsorption and adsorption capacity may diminish due to competition with adsorber metabolites or other bacterial byproducts. Metabolic end products of some compounds may be irreversibly adsorbed, reducing the mass of target contaminants that can be removed by adsorption (Schultz and Keinath, 1984).

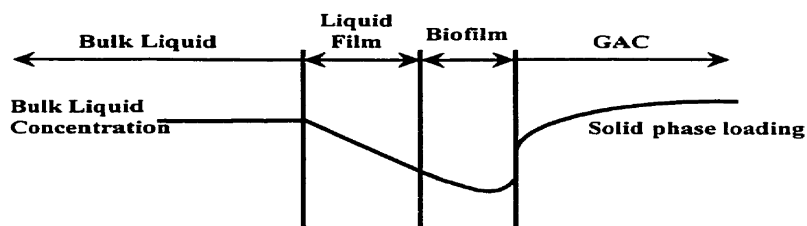
Adsorption, desorption and biodegradation each contribute to bioregeneration. Li and DiGiano (1983) first presented theories of the interactions among these mechanisms during bioregeneration. Figure 2.8 (Speitel, 1985) presents hypothetical concentration profiles for a single GAC particle at different times during bioregeneration.



a) Initial period of adsorption; negligible biomass



b) Development of biofilm



c) Bioregeneration

Figure 2.7 Concentration Profiles at Different Times during Bioregeneration (Andrews and Tien (1981) and Speitel (1985))

Figure 2.7a shows the concentration profiles in the bulk liquid, laminar liquid film surrounding the particle, and in the internal pores of the particle during the early stages of contact. Initially no biofilm is present on the outer surface of the GAC particle, and contaminants are removed by adsorption only (Figure 2.7a). Solid phase loading is not in equilibrium with the bulk liquid phase concentration, and contaminants diffuse from the bulk liquid into the GAC. It is important to note that the distribution ratio between the solid and the liquid phase concentration can be very large because many organics are adsorbed strongly. Bulk substrate concentration will be low because adsorption equilibrium has not been reached yet. The solid phase concentration, q (mass of substrate adsorbed per mass of GAC), will decrease with distance away from the solution interface until equilibrium with the feed solution occurs. As adsorption continues, the carbon loading, q , increases at all positions within the particle. Simultaneously, substrate concentration adjacent to the

particle increases until equilibrium between the solid and liquid phase is reached. The increase in bulk substrate concentration encourages microbial growth and biomass attachment onto the GAC.

After initial establishment of the biofilm (Figure 2.7b), contaminants diffuse into the biofilm, where a portion of the organic matter is biodegraded by the limited amount of biomass. Net radial flux of contaminants remains into the GAC. Solid phase loading continues to increase as adsorption remains the primary mechanism of contaminant removal from the liquid phase.

As the biofilm thickens and the biodegradation rate increases, bioregeneration commences (Figure 2.7c). Liquid phase organic contaminants that diffuse into the biofilm are consumed. Biodegradation reduces the organic matter concentrations in the biofilm and at the boundary between the biofilm and the exterior surface of the GAC. In response to the change in direction of the biofilm and the exterior surface of the GAC, reversibly adsorbed contaminants desorb from the GAC.

Bacteria are generally too large to fit inside the GAC pores; thus, biodegradation occurs only in the biofilm. A concentration minimum is established in the biofilm, indicating diffusive mass transfer from both the liquid and solid phases into the biofilm and bioregeneration of GAC.

Either desorption or biodegradation will typically limit the rate of bioregeneration. Goeddertz et al. (1988) found that the effectiveness of their BAC process was dependent on the biodegradation rate. If the mass loading rate of contaminant to the BAC column was greater than the biodegradation rate, the adsorption capacity was eventually exhausted. Hutchinson and Robinson (1990) found that desorption kinetics controlled the bioregeneration rates in an off-line system.

Complete bioregeneration can occur only if the liquid concentration decreases to zero due to biodegradation; otherwise, some portion of the contaminant remains adsorbed and has no concentration gradient that drives desorption from the GAC. In reality,

complete bioregeneration may be impossible because minimum substrate concentrations achievable by biodegradation are non-zero (Speitel et al., 1987).

2.3.9. Desorption of Organic Compounds and Bioavailability

The rate of contaminant desorption from the solid phase may limit biotransformation of NOM including soil and GAC. Desorption from GAC (or any other adsorbent) occurs in response to changes in global or local operating conditions of an adsorber such as (Thacker et al., 1983):

1. A decrease in the liquid phase concentration, which creates a concentration gradient that drives the substrate out of the solid phase and into the liquid.
2. Displacement of adsorbed solutes by competitive adsorption
3. Some other change in the liquid phase (such as pH) that alters equilibrium conditions and decreases adsorbability.

Strong adsorption of compounds to GAC, and thus lack of desorption can limit bioregeneration (Speitel et al., 1989)

2.4. Modeling Biological NOM Removal in Drinking Water Treatment Filters

One of the fastest and most cost effective methods for evaluating a treatment process such as biofiltration is through use of a simulation model. Although not a substitute for laboratory experiment or pilot tests, properly designed and calibrated models permit the extension of limited experimental results to many cases which would be too time consuming and costly to evaluate otherwise. In order to enable the design of biofilters for NOM-removal in drinking water treatment without prior experimental on site investigations, models were developed which aimed to give a closed description of the processes taking place in such bioreactors.

A lot of modeling work has been done yet. A review of the literature revealed limited information on the modeling of drinking water biofilters, particularly under non-steady-state conditions.

Rittmann and McCarty (1978) developed one of the first models for description of steady-state conditions in completely mixed fixed bed bioreactors for drinking water treatment.

Later Saez and Rittmann developed a pseudo analytical solution for this model, which is commonly referred to as S_{\min} model. Wang and Summers (1995) developed a model which is suitable to describe the removal of biodegradable organic carbon (BDOC) in deep bed filters.

Also Hozalski (1997) developed a model for biofiltration. His goal was to explicitly simulate the effect of filter-backwashing on the removal of biodegradable organic matter.

A model which does not need calibration for the specific site or the measurement of site-specific parameters like bacterial concentration as a function of bed depth was developed by Billen et al.(1992) and called Chabrol- Model. This model aims to predict the kinetics of BOM removal in biological filters for different substrates combinations.

Uhl's model (2000b) can be used for design of bioprocesses for NOM removal without further on site experimental work and this model gives a closed description of the processes as biodegradation, attachment and detachment of bacteria taking place in the filter bed as a function of bed depth.

2.4.1. Uhl's Model

The model developed treats the filter bed as fixed bed plug flow reactors. Based on a broad review of literature on biodegradation in natural and technical aquatic environments, the following assumptions were made:

- Mainly bacteria that can be counted by the heterotrophic plate count method (HPC-bacteria) are actively growing and utilizing biodegradable NOM for growth.
- The HPC bacteria as well as the biodegradable substrate can be treated as a statistical unit, i.e., homogenous with respect to degradation capabilities, growth kinetics and biomass yield.

- The bacteria are capable to degrade the substrate at any low substrate concentration. No physiological threshold exists.
- Bacteria attaching to the media surfaces have the same physiology as suspended bacteria and therefore growth and substrate consumption can be described with the same kinetic relationships and parameter values.
- There is no direct uptake of the adsorbed substances. If already adsorbed substances are degraded, they are first desorbed as a result of decreased concentrations in the liquid phase and diffuse into the liquid before taken up.

Balancing biodegradable NOM, i.e. substrate with concentration S , in a reactor volume element of length dz yields

$$\left(\frac{\partial S_z}{\partial t}\right) = r_{s,gr} + r_{s,maint} + r_{s,cat} - \frac{Q}{A \times \epsilon_{bed}} \times \left(\frac{\partial S_z}{\partial z}\right) \quad (2.3)$$

where the index z indicates bed depth. $r_{s,gr}$ and $r_{s,maint}$ are the rates of substrate consumption by bacterial growth and maintenance requirements and $r_{s,cat}$ is the production of the biodegradable substrate by surface catalytic processes. Q is the volumetric flow rate, A is the filter bed area and ϵ_{bed} is the filter porosity.

Suspended bacteria concentration (X_{sus}) are balanced as:

$$\left(\frac{\partial X_{sus,z}}{\partial t}\right) = -\frac{1}{\epsilon_{bed}} (a_{bed} \times j_{x,att} - a_{bed} \times j_{x,det}) - \frac{Q}{A \times \epsilon_{bed}} \times \left(\frac{\partial X_{sus}}{\partial z}\right) \quad (2.4)$$

where $j_{x,att}$ and $j_{x,det}$ are the fluxes of suspended bacteria to the surface and detaching from the media surface respectively. Growth of suspended bacteria is neglected as their concentration was found to be several orders of magnitude lower than the concentration of attached bacteria.

Analogously, attached bacteria concentration (X_{att} , in bacteria per unit filter volume) are balanced as

$$\left(\frac{\partial X_{att,z}}{\partial t} \right) = (a_{bed} \times j_{x,att} - a_{bed} \times j_{x,det}) + (r_{x,gr} + r_{x,mort} + r_{x,graz}) \quad (2.5)$$

where $r_{x,gr}$, $r_{x,mort}$ and $r_{x,graz}$ are the rates for bacterial proliferation, mortality and their decimation by grazing protozoa.

The growth rate is described by the Monod-equation with temperature dependency according to the Arrhenius-law:

$$r_{x,gr} = \mu_{max} \frac{S}{K_s + S} X_{att} \quad (2.6)$$

and

$$\mu_{max}(T) = \mu_{max} T_{meas} \exp\left(\frac{-E_a}{R_0} \left(\frac{1}{T} - \frac{1}{T_{meas}}\right)\right) \quad (2.7)$$

with μ_{max} the maximum growth rate and K_s the Monod-half rate constant, E_a the Arrhenius activation energy, R_0 the universal gas constant and T_{meas} the temperature at which $\mu_{max}(T_{meas})$ was determined

Substrate depletion rate due to conversion into biomass is described by

$$r_{s,gr} = -\frac{1}{Y_{x/s}} \cdot \frac{1}{\epsilon_{bed}} \cdot r_{x,gr} \cdot (bV \cdot bCc \cdot \frac{1000ml}{l}) \quad (2.8)$$

where $Y_{x/s}$ is the yield coefficient for biomass from substrate (mg bacterial carbon per mg substrate carbon), bV is the mean biovolume of the heterotrophs entering and leaving the filter and bCc the bacterial content in mg bacterial carbon per unit of biovolume. Mass transfer of substrate to the attached bacteria is considered not to be a rate limiting process. The simulations by Wang and Summers (1994) had shown that mass transport would play

a negligible role. Also, in his studies, Urfer (1998) had found that reaction rate was always limiting, not the mass transfer.

Bacterial mortality, ($r_{x,mort}$) is described by

$$r_{x,mort} = -k_d \cdot X_{att} \quad (2.9)$$

with k_d the decay coefficient.

Substrate consumption for maintenance requirements with the maintenance coefficient m_s by

$$r_{s,maint} = -m_s \cdot X_{att} \quad (2.10)$$

For kinetic description of grazing by protozoa it has to be considered that the rate at which a single protozoa is grazing bacteria is proportional the sessile bacteria concentration, i.e. the rate of protozoan proliferation $r_{prot,gr}$ is described by

$$r_{prot,gr} = -k_{prot,gr} \cdot X_{att} \cdot X_{prot} \quad (2.11)$$

with the rate coefficient $k_{prot,gr}$ in ml/CFU.h. The protozoan concentration is diminished by mortality with the rate coefficient $k_{d,prot}$. The relationship between protozoa and bacteria is a typical predator-prey-relationship. If the time period in relation to the time required for one amplitude is investigated, the concentrations can be treated as in quasi steady state. For such a situation the rate of grazing by protozoa is equal the rate of bacterial proliferation and decay and the grazing rate can be expressed with

$$r_{X,graz} = -\left[\frac{(\mu_{max} - k_d) \cdot S - k_d K_s}{K_s + S} \right] \cdot X_{att} \quad (2.12)$$

The rate of bacterial attachment to the filter media is usually described by the Iwasaki-law which is equivalent to a first order rate equation. As bacterial attachment to

surfaces can mostly be described by a Langmuir-type adsorption isotherm, kinetic constants for attachment and detachment were derived from adsorption isotherms determined in batch experiments. From this approach the rate of bacterial attachment to the surface, $r_{x,att}$ is described by

$$r_{x,att} = -k_{att,bed} \cdot X_{sus} \cdot (X_{att,max} - X_{att}) \quad (2.13)$$

with the rate coefficient $k_{att,bed}$ for attachment. $X_{att,max}$ is the maximum attached bacteria concentration according to the Langmuir relationship.

For the rate of detachment also the Langmuir-relationship is used. Furthermore it is taken into account that there is only a limited probability that bacteria formed by proliferation of already attached bacteria remain attached. Commonly, proportionality between growth rate of attached bacteria and detachment is found. Taking this into account yields

$$r_{x,det} = -k_{det,bed} \cdot X_{att,bed} + f_{det} \cdot r_{x,gr} \quad (2.14)$$

where $k_{det,bed}$ is the rate coefficient for detachment from the Langmuir relationship and f_{det} is a dimensionless factor between 0 and 1.

Principally the model is suited for dynamic simulations. At first quasi-steady-state calculations were carried out. They aimed to give impression about the steady state situations expected and to compare them with measured results.

For simulation equations, following equations have to be integrated from the reactor inlet to the bed depth at the reactor outlet. Integration was carried out numerically with a fourth order Runge-Kutta method with variable step length.

$$\frac{dS}{dz} = \frac{\varepsilon_{bed}}{\nu} (r_{s,gr} + r_{s,maint} + r_{s,cat}) \quad (2.15)$$

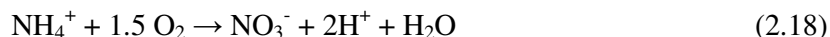
$$\frac{dX_{sus}}{dz} = -\frac{1}{v}(r_{x,att} - r_{x,det}) \quad (2.16)$$

$$\frac{X_{att}}{X_{att,max}} = \left[1 + \frac{k_{det}}{k_{att} X_{sus}} - \frac{(1-k_{det})\mu_{max} S}{(K_s + S)k_{att} X_{sus}} + \frac{k_d \frac{[(\mu_{max} - k_d)S - k_d K_s]}{K_s + S}}{k_{att} X_{sus}} \right]^{-1} \quad (2.17)$$

2.5. Nitrification in Biological Activated Carbon Column Systems

2.5.1. Nitrification Fundamentals

The recycling of nitrogen in the environment is essential to life's existence. Nitrification, a multi-step biological process, is an important part of the nitrogen cycle and also an integral component of water treatment systems. The overall reaction that defines nitrification is the conversion of ammonia to nitrate. Nitrate is a more oxidized form of nitrogen that can be utilized by plants and other bacteria. It is accomplished by members of a group of bacteria called autotrophs. Autotrophic micro-organisms oxidize inorganic constituents to obtain energy for growth and maintenance, while they obtain carbon for the production of new biomass by the reduction of carbon dioxide. Organic matter is not required for the growth of autotrophic bacteria. Nitrification is actually a two-step reaction. Ammonia is first oxidized to hydroxylamine (NH_2OH), an intermediate, by ammonia monooxygenase (AMO) and NH_2OH is further oxidized to nitrite by hydroxylamine oxidoreductase (HAO) (Jianlong and Ning, 2004). This reaction is carried out by chemolithoautotrophic ammonia-oxidizing bacteria (AOB).

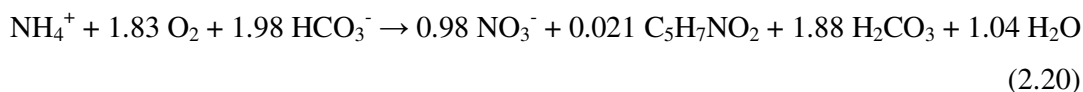


The second step is the oxidation of nitrite-nitrogen to nitrate-nitrogen by nitrite-oxidizing bacteria (NOB).



Nitrite oxidation is mediated by nitrite oxidase, and is believed to proceed without the formation of any chemical intermediates.

Under steady-state conditions these two reactions will be in balance and the overall reaction will go essentially to completion. Including the synthesis of new biomass (expressed as the typical composition of biomass), the overall reaction is:



Equation 2.20 illustrates the stoichiometry of nitrification reaction. The oxygen required for complete oxidation of ammonia is 4.57 mg of O_2 for each mg of N oxidized, with 3.43 mg O_2 /mg used for nitrite production and 1.14 mg O_2 /mg nitrite oxidized. When synthesis is considered, the amount of oxygen required is less than 4.57 mg O_2 /mg N (Metcalf and Eddy, 2003).

Bicarbonate alkalinity is also consumed in the reaction to both neutralize the acid produced (i.e. ammonia-nitrogen is a base while nitrate-nitrogen is an acid) and as required for the synthesis of new biomass (from carbon dioxide which is present as bicarbonate alkalinity). The overall transformations of nitrogen in biological systems are depicted in Figure 2.8.

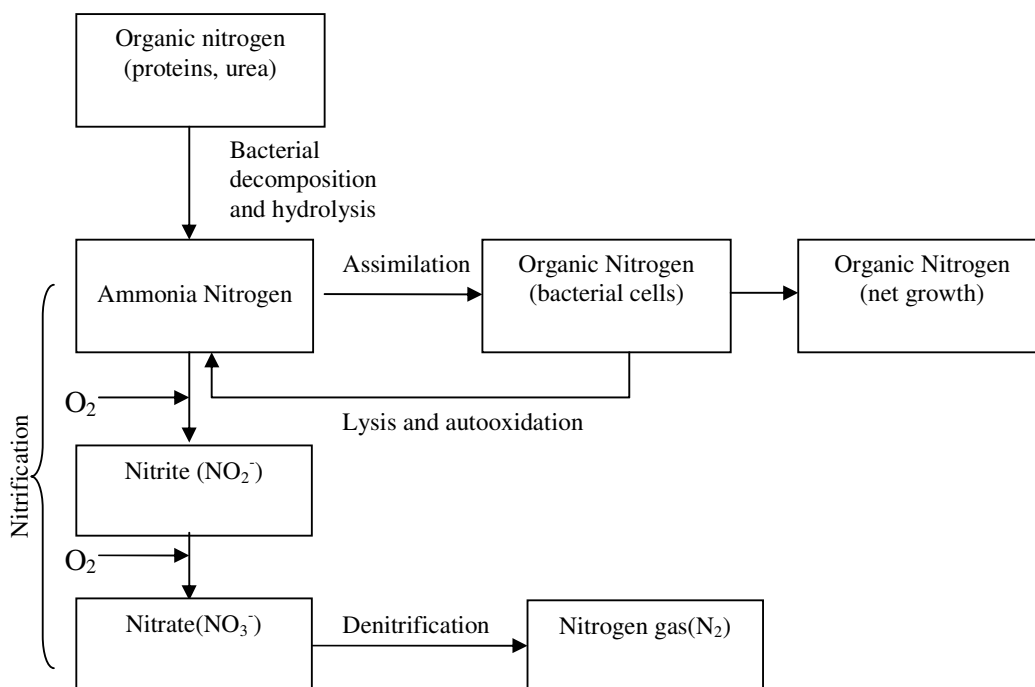


Figure 2.8 Transformations of nitrogen in biological systems

2.5.2. Ammonia in Drinking Water

Nitrogen occurs in raw surface water used for drinking water production under the form of organic nitrogen, ammonia, nitrite, and nitrate, all of which are undesirable in drinking water. The European Community has regulated some of these substances in the

EC standards for nitrogen compounds in potable water (EC 80/779, 1980): 10 mg/L of nitrate (NO_3^- -N), 0.1 mg/L of nitrite (NO_2^- -N), and 0.05 mg/L of ammonia (NH_4^+ -N). The Environmental Protection Agency (USEPA, 2000) recommended a value of below 0.02 mg/L NH_4^+ -N. Increasing concentrations of ammonia in raw water and the possible future restriction of legislation underline the emergency to look for processes capable of producing better quality of drinking water.

The presence of ammonia in source waters is undesirable since;

- It reduces the aesthetic quality of drinking water such as color and odor.
- It serves as electron donor for nitrifiers and nitrogen source for other microorganisms respectively, which facilitates bacterial growth and the formation of biofilm in the distribution system.
- Since ammonia is a chlorine-consuming agent, the chlorine demand during disinfection increases, which results in the formation of mutagenic disinfection byproducts (DBPs) such as THMs and HAAs. (Bouwer and Crowe, 1988; Diehl et al., 2000; Lipponena et al., 2002).

Ammonia can be removed by both physicochemical and biological processes in drinking water production. Physicochemical ammonia removal in drinking water can be done using processes like ion exchange, zeolite filtration, micro filtration, reverse osmosis or chemical oxidation. Break point chlorination is one alternative to treat ammonia by chemical means. It consists of a continual addition of chlorine to the water up to the point where the chlorine enquiry is met and all present ammonia is oxidized. In addition, a high chlorination level usually induces, by reaction between organic matter and chlorine, the formation of disinfection by-products such as trihalomethanes (THM), known to be potentially carcinogenic. An alternative to break point chlorination is ion-exchange which provides a technique which is responsive to shock loading and can operate at lower (and higher) temperatures. A significant drawback of ion-exchange is the need for regeneration which can incur associated reagent costs. Another possible drawback is that desorption may occur due to shift in the exchange equilibria when the ammonia concentration in the influent drops. This may result in the discharge of ammonia into the eluent stream.

At present, biological processes, like fluidized bed bioreactors (Summerfelt, 2006), moving bed biofilm reactors (Rusten et al., 2006), trickling filters (Tekerlekopoulou and Vayenas, 2008), membrane bioreactors (Urbain et al., 1996; Li and Chu, 2003), submerged bio-oxidation, ozone - BAC (Takeuchi et al., 1997; Uhl and Gimbel, 2000; Andersson et al., 2001; Yu et al., 2007; Traenckner et al., 2007) and other biofiltration processes are applied for nitrification. Nitrification, the biological conversion of ammonia to nitrite and nitrate is the common method of ammonia oxidation in wastewater and water treatment (Bouwer and Crowe, 1988; Metcalf & Eddy, 2003).

2.5.3. Nitrification in Biofilters

Filtration on biological granular activated carbon (GAC) was proved to be efficient in removing biodegradable dissolved organic carbon (BDOC) (Servais et al., 1991, 1992) and this process can also be used to simultaneously remove ammonia (Bablon et al., 1988; Niquette et al., 1998) by biological oxidation. In water treatment plants where post chlorination is applied as disinfection, the presence of ammonia is especially problematic. Theoretical consumption of chlorine is $7.6 \text{ mg Cl}_2 / \text{mg NH}_4\text{-N}$. To be on the safe side, $10 \text{ mg Cl}_2 / \text{mg NH}_4\text{-N}$ is used in practical applications. Therefore, even a small amount of ammonia removal can decrease the applied chlorine concentration. If nitrification is properly optimized, nitrite accumulation in the system can be greatly reduced which results from incomplete oxidation of ammonia.

Different filter media types, like GAC (Uhl and Gimbel, 2000; Andersson et al., 2001), sand (Kihn et al., 2000; Traeckner et al., 2008), combined zeolite and ion exchange resins (Miladinovic and Weatherley, 2008), sand-anthracite dual media (Wert et al., 2008), GAC-sand dual media (Yu et al., 2007) were used for nitrification by biofiltration by several authors (Bablon et al., 1988; Kihn et al., 2000).

Kihn et al. (2000) developed a technique to estimate fixed nitrifying biomass by potential nitrifying activity measurement. The production of oxidized forms of inorganic nitrogen (nitrates and nitrites) was measured after an incubation of 2 cm^3 of colonized solid support in the presence of a 5 mL nitrifier medium containing $10 \text{ mg/L NH}_4\text{-N}$ for 30

min at 32 °C. The production rate of oxidized nitrogen in optimal conditions was measured and converted into nitrifying biomass by using the maximum specific oxidizing activity.

Recently, another study to estimate the nitrifying biomass was conducted by Traeckner et al. (2008). An analytical approach based on balancing growth, decay and biomass removed by backwashing was proposed. The method was developed and applied in pilot-scale rapid sand filters for drinking water treatment.

Andersson et al. (2001) investigated the impact of temperature on nitrification in BAC filters both in pilot-scale and full-scale with an average $\text{NH}_4\text{-N}$ concentration of 0.4 mg/L. The results indicated a strong temperature impact on nitrification activity. Ammonia removal capacities ranged from 40 to 90 % in pilot filters, at temperatures above 12 °C, while more than 90 % ammonia was removed in the full-scale filters for the same temperature range. At moderate temperatures (4-10 °C), filters removed 10-40 % of incoming ammonia.

Yu et al. (2007) tried to explain the mechanism of nitrogen loss that observed in the full-scale biofilters. The nitrogen and DO balances indicated that about one third of $\text{NH}_4^+\text{-N}$ was lost and the actual DO consumption was about 30 % lower than the theoretical dissolved oxygen demand if nitrification was regarded as the only pathway to remove $\text{NH}_4^+\text{-N}$. They concluded that anaerobic ammonia oxidation (ANAMMOX) was the probable pathway for this observation. However, no molecular biological tools were applied in order to clarify this situation.

In pilot-plant studies, Wert et al. (2008) found that variable filtration rates (4.8–14.6 m/h) did not affect the removal of BOM. However, nitrification performance was reduced by 60 % at higher filtration rates (14.6 m/h). Therefore, lower filtration rates were recommended to develop nitrification within a biofilter. In the same study, they also found that chlorinated backwash water allowed the development of biological filtration for BOM removal, but inhibited the development of nitrification.

Nitrification in drinking water pipe surfaces was also investigated by several researchers. For example, Pintar and Slawson (2003) studied the establishment of

ammonia-oxidizing bacteria (AOB) in chloraminated distribution systems in a bench-scale distribution system. The potential significance of temperature and disinfectant residual associated with chloramination in full-scale drinking water distribution systems was assessed.

Lipponen et al. (2004) applied the traditional most probable number (MPN) enumeration and molecular biological techniques to study the population dynamics of nitrifiers during the biofilm development on PVC pipes connected to two full-scale chloraminated drinking water distribution systems.

2.6. Molecular Tools for Identification of Microorganisms

One of the most fundamental discoveries made by microbiologists during the last decade has been the realization that the vast majority of bacteria in the environment have not yet been cultured (Amann et al., 1995). Using molecular biological tools and employing the 16S rRNA gene as a marker, microbiologists have been able to identify the presence of novel, uncultured organisms in situ. These 16S rRNA-based approaches have led to estimates of prokaryotic biodiversity and surveys of the microbial community structure of many environments (Britschgi and Giovannoni, 1991; Ward et al., 1992; Wise et al., 1997).

At present, one of the most burning questions is the relationship between the microbial communities as described by these culture-independent methods and community structure assessment based on culturing. Investigators exploring the wide range of microbial diversity with universal- or domain-specific 16S rRNA probes or primers have only rarely reported the isolation of novel organisms whose presence was suggested by sequence analysis (Kane et al., 1993; Suzuki et al., 1997).

The identification of microorganisms after prior cultivation shows two serious disadvantages: first, environmental studies indicate that only 0.1-10% of all bacteria can be cultivated. Second, several studies proved the existence of cultivation shifts which means that some microbial groups are favored under cultivation conditions whereas other groups have no chance to compete. The consequence is not only that the main part of archaea or bacteria cannot be detected in environmental samples but also that the detected microorganisms do not represent the "real" population structure. For this reason, culture independent methods, such as rRNA based molecular techniques, are important tools for examination of microorganisms in their environment.

The 16S rRNA molecule is an excellent marker to infer phylogeny because it is found in all cellular life form. It comprises highly conserved regions interspersed with more variable ones. The variable regions allow the comparison of sequences, and some of the conserved portions can be recognized as signature sequences for the domains *Archaea*, bacteria, or eukaryote (Head et al., 1998). Conserved regions also allow the development

of useful primers or probes (Giovannoni et al., 1988), which enable the amplification or identification of sequences down to species level.

The applications of rRNA-based nucleic acid techniques to the analysis of treatment systems today range from a simple identification of isolates over the detection of bacterial diversity and population dynamics to attempts at fully and quantitatively describing the complex microbial communities. Several rRNA based methods have been developed to identify and quantify microorganisms in environmental samples such as polymerase chain reaction (PCR), denaturing gradient gel electrophoresis (DGGE), fluorescence in situ hybridization (FISH) and slot-blot hybridization. These are powerful techniques in the identification of microbial populations in combination with cloning and DNA sequencing.

2.6.1. Polymerase Chain Reaction (PCR)

Polymerase chain reaction has rapidly become one of the most widely used techniques in molecular biology for many reasons: it is a rapid, inexpensive and simple means of producing relatively large numbers of copies of DNA molecules from minute quantities of source DNA material even when the source DNA is of relatively poor quality.

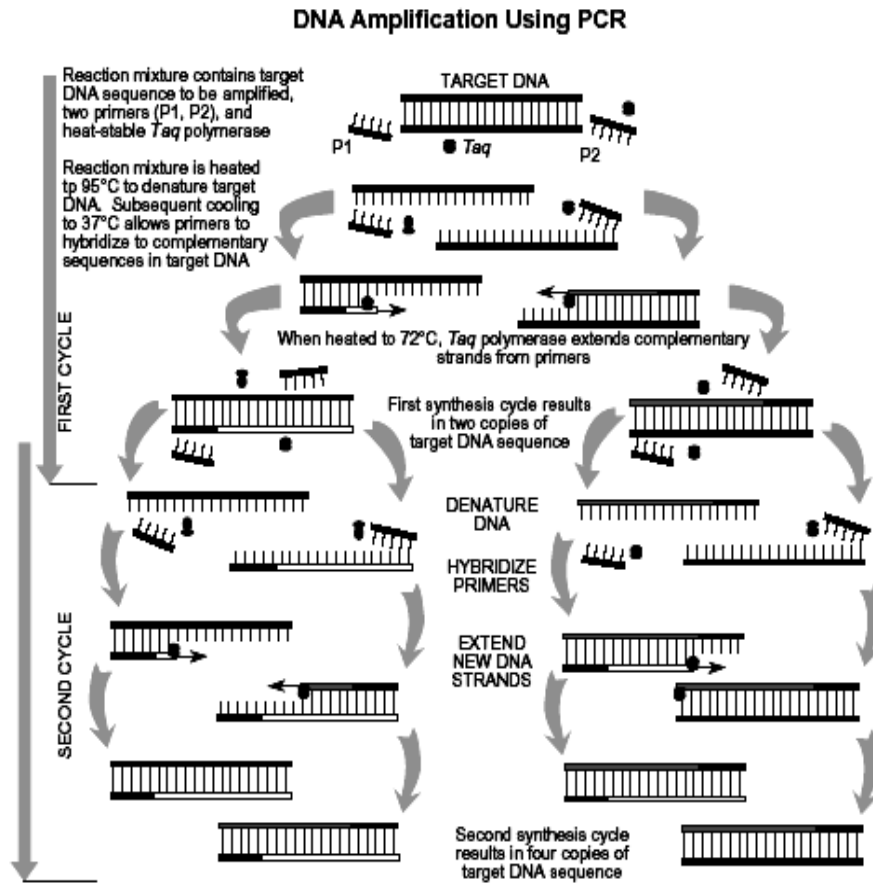


Figure 2.9 Overview of polymerase chain reaction (PCR) principles.

There are three basic steps in PCR. First, the target genetic material must be denatured—that is, the strands of its helix must be unwound and separated by heating to 90–96°C. The second step is hybridization or annealing, in which the primers bind to their complementary bases on the now single-stranded DNA. The third is DNA synthesis by a polymerase. Starting from the primer, the polymerase can read a template strand and match it with complementary nucleotides very quickly. The result is two new helices in place of the first, each composed of one of the original strands plus its newly assembled complementary strand (Figure 2.9).

All PCR really requires in the way of equipment is a reaction tube, reagents, and a source of heat. But different temperatures are optimal for each of the three steps, so machines now control these temperature variations automatically. To get more of the DNA you want, the process must be repeated by denaturing the present DNA. The amounts will

double every time. With the cycle of rapid heating and cooling controlled automatically, nature-aided by scientist-supplied primers, polymerase, nucleotides, and chemical reagents-does the rest. Each cycle takes only 1-3 minutes, so repeating the process for just 45 minutes can generate millions of copies of a specific DNA strand. Once the primers have been characterized and obtained, PCR can do in a week work that used to take a year.

The amplification product is visualized by agarose gel electrophoresis. Although the PCR technique was originally used for genetic and clinical purposes, this technique has been used to detect and monitor microorganisms in complex environmental samples for a number of years (Bej et al., 1991b). By exponentially amplifying a target sequence, PCR significantly increases the probability of detecting rare sequences in mixtures of DNA. Numerous studies have reported the detection of specific microorganisms in water, soils and sediments by PCR amplification without the need for cell cultivation (Bej et al., 1991a).

2.6.2. Denaturing Gradient Gel Electrophoresis (DGGE)

DGGE is a gel-electrophoretic separation procedure for double stranded DNA's of equal size but with different base-pair composition or sequence (Muyzer and Smalla, 1998). In principle, the method is sensitive enough to separate DNA's on the basis of single point mutations. This technique is gaining increased popularity in microbial ecology for analyzing the diversity of total bacterial communities. Briefly, the 16S rRNA genes are amplified using the appropriate primer pair, one of which has a G+C "clamp" attached to the 5' end that prevents the two DNA strands from completely dissociating even under strong denaturing conditions. During electrophoresis through a polyacrylamide gel containing denaturants, migration of the molecule is essentially arrested once a domain in a PCR product reaches its melting temperature (Figure 2.9). Following staining of the DNA, a banding pattern emerges that represents the diversity of the rRNA gene sequences present in the sample. The intensity of an individual band is a semi-quantitative measure for the relative abundance of this sequence in the population.

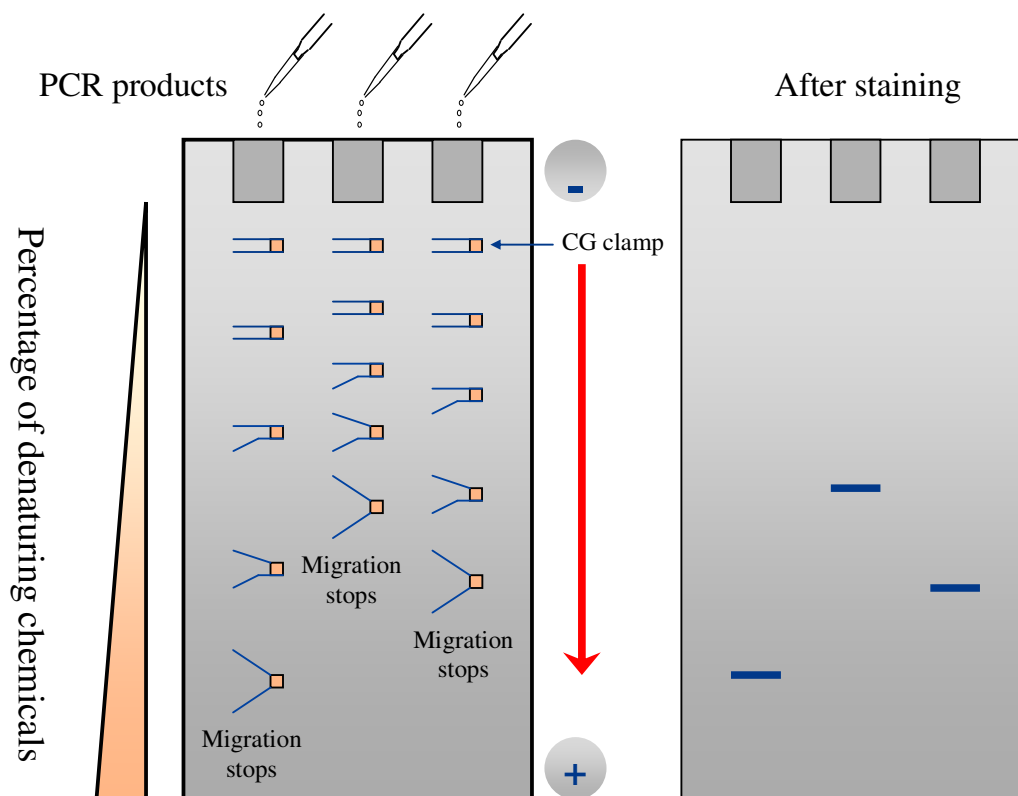


Figure 2.10 Overview of denaturing gradient gel electrophoresis experiment.

Whereas DGGE analysis of rDNA PCR products is a powerful tool to analyze diversity and dynamics of microbial communities, it has severe limitations in the analysis of community structures, and is like any other method prone to specific biases:

- The method involves extraction of nucleic acids and subsequent PCR, which may both cause some bias: Not all cells lyse under the same conditions and preferential amplification of certain templates can occur (Suzuki and Giovannoni, 1996). Therefore, different intensities of DGGE bands must not be interpreted as quantitative measures of the abundance of species relative to each other.
- Separation of DNA fragments with high resolution is restricted to a maximum size of about 500 bp. Consequently, the phylogenetic information that can be retrieved by sequencing is relatively little. In case of full identity with an rRNA sequence in a database it might be sufficient for identification, but in cases in which only distantly related sequences are available classification becomes difficult if not impossible.

- The main difficulty, however, is the “one band-one species” hypothesis. Especially in complex communities bands might originate from two or more fragments that co-migrate on the denaturing gradient gel. Furthermore, single species might result in two or more DGGE bands due to inter-operon micro-heterogeneity (Nübel et al., 1996).

2.6.3. Fluorescence In Situ Hybridization (FISH)

Fluorescence in situ hybridization (FISH) with rRNA-targeted probes is a staining technique that allows phylogenetic identification of bacteria in mixed assemblages without prior cultivation by means of epifluorescence and confocal laser scanning microscopy, or by flow cytometry (Amann et al., 1996). FISH with polynucleotide DNA probes and FISH with oligonucleotide probes targeted to mRNA has also been described by several authors (Trebesius et al., 1994; Wagner et al., 1998; DeLong et al., 1999).

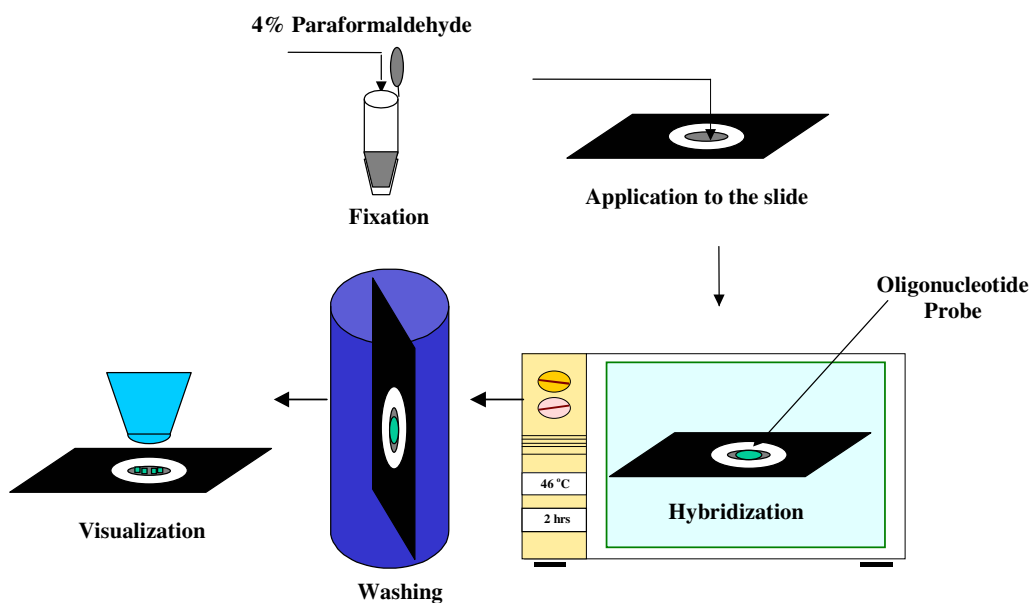


Figure 2.11 Overview of fluorescence in situ hybridization (FISH) steps.

The principles of in situ hybridization with fluorescently labeled, rRNA-targeted oligodeoxyribonucleotides are quite straightforward. First, the morphology of the cells in the examined sample has to be stabilized and the cell walls and membranes have to be

permeabilized for the penetration of the probes. This can be both achieved with fixatives, which are usually based on aldehydes and/or alcohols. Subsequently, the probes are applied in an adequate hybridization buffer and incubated at an adequate hybridization temperature (usually between 35 and 50°C) for one to several hours. Washing steps are applied to remove unbound and part of the non-specifically bound fluorescent probe and the sample can subsequently be analyzed by epifluorescence microscopy (Figure 2.11). Several probes labeled with spectrally different fluorochromes can be simultaneously used on one sample, e.g. a fluorescein-labeled probe that emits green light upon blue excitation, together with the orange-red Cy3. The sensitive visualization of the latter requires a CCD camera.

2.6.4. Slot-Blot Hybridization

This technique is useful to measure the amount of a specific 16S rRNA in a mixture relative to the total amount of rRNA. Briefly, total DNA and RNA are isolated from the sample, bound to a filter using a dot or slot manifold device and hybridized with labeled oligonucleotide probes. The amount of label bound to the filter is a measure of the specific rRNA target present, and the relative amount of rRNA may be estimated by dividing the amount of specific probe by the amount of labeled universal probe hybridized under the same conditions. Obviously, the relative amount of rRNA sequence does not reflect the true abundance of the microbe since cells of different species have different ribosome contents and the number of ribosome within one strain will vary with growth phase. Nevertheless, the relative quantity of rRNA provides a reasonable measure of the relative physiological activity of a specific population.

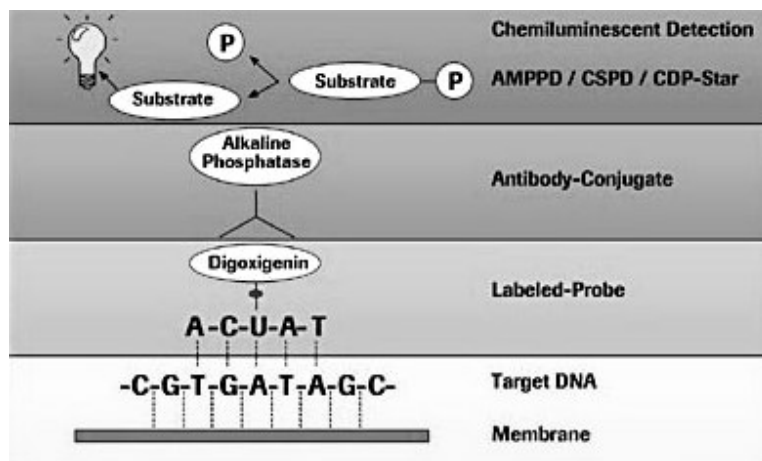


Figure 2.12 Overview of slot-blot hybridization experiment.

For dot blot or slot blot hybridization total RNA or DNA is extracted from an environmental sample and immobilized (“blotted”) on a nylon membrane (Stahl et al., 1988). DNA oligonucleotide probes are labeled with ^{32}P (Stahl et al., 1988), or – with a significant loss of sensitivity non-radioactively with digoxigenin (DIG) (Manz et al., 1992). Hybridization conditions are optimized by adjusting the final wash temperature to provide adequate sensitivity and specificity relative to RNA extracted from reference organisms. Processing of the membrane including prehybridization, hybridization, and washing takes several hours. Subsequently, bound probe is quantified by phosphorimaging or densitometry after autoradiography in case of ^{32}P or enzymatic antibody detection of probe-conferred DIG, respectively. The relative abundance of a certain 16S rRNA is expressed as a fraction of total 16S rRNA in the sample, which is determined by hybridization of a universal oligonucleotide probe (Stahl et al., 1988). The DIG System is an effective system for the labeling and detection of DNA, RNA, and oligonucleotides. The protocols for labeling with digoxigenin (Figure 2.12) and subsequent detection are based on well-established, widely used methods.

2.6.5. Real-time PCR

Recently developed molecular tools include sequence analysis of the 16S rRNA and *amoA* genes to reveal AOB populations and communities in various environments. In combination with clone libraries or denaturing gradient gel electrophoresis (DGGE), the application of specific PCR amplification provides clarification of the ammonia oxidizing

community in detail. Implementation of fluorescence in situ hybridization (FISH) makes it possible to analyze complex communities of ammonia-oxidizing bacteria and estimate their numbers. A novel methodological approach for quantifying the bacterial abundances in the environment is real-time PCR. This method is a fast and accurate tool to obtain an insight into the community size of nitrifiers and denitrifiers in both natural and engineered environmental samples (Dionisi et al., 2002; Okano et al., 2004; Petersen et al., 2004).

The LightCycler system (Roche) enables RT-PCR to be carried out in small capillaries, capable of holding up to 20 μ L of sample, contained within a rotor-like carousel that is heated and cooled in an air stream. One of the greatest advantages that the LightCycler instrument offers in comparison to conventional thermal cyclers is that the formation of amplification products can be monitored in real time. Currently, the LightCycler system supports two fluorescence-based methods for the detection of amplification products: SYBR Green and hybridization probes. The undoubted advantage that the LightCycler system offers over all other real-time systems is reaction speed. High-speed thermal cycling is achieved using air instead of thermal blocks. Due to the special design of the thermal chamber, samples are held under uniform temperature conditions. The unique capillary sample tube system ensures efficient heat transfer to the PCR samples. As a result, the time needed for each PCR cycle, including measurement of the sample fluorescence, is minimized to approximately 15 to 20 s. A 30-to 40-cycle PCR run is typically completed within 20 to 30 min, with quantitative PCR methods capable of being completed in less than 1 h.

In real-time PCR analyses, quantification is based on the threshold cycle C_t , which is inversely proportional to the logarithm of the initial gene copy number. The threshold cycle values obtained for each sample should be compared with a standard curve to determine the initial copy number of the target gene (Geets et al., 2007). Real-time PCR is a method used to detect PCR amplicons during the early exponential phase of the amplification reaction based on the fluorescent dye SYBR-Green I (Molecular Probes), which binds to double-stranded DNA during PCR amplification.

3. STATEMENT OF THE PROBLEM

The objective of drinking water treatment is to supply consumers a high quality water with respect to bacteriology, toxicology and aesthetics. The type and level of treatment required depend on the quality of raw water utilized. The presence of natural organic matter (NOM) in raw water sources is one of the major concerns of water utilities, especially with respect to its reactions with disinfectants and its utilization as a substrate by microorganisms. Components of NOM can react with disinfectants during disinfection of water to form disinfection by-products, some of which are of health concern. Biodegradable NOM can serve as a carbon and energy source for microorganisms present in water, which results in microbial regrowth problems in distribution systems. Some of these microorganisms may be pathogenic. NOM can also have a negative effect on the color, taste and odor of drinking water. Conventional treatment with coagulation, flocculation, sedimentation, filtration and chlorination was not originally designed to remove NOM in drinking water and thus has limited control on NOM. Additional treatment, such as that provided by biological processes will be needed to economically control the biodegradable fraction of NOM.

In addition to NOM, the presence of ammonia is also associated with biofilm growth. Although ammonia in water does not pose a direct health concern, nitrification of significant levels of ammonia may cause problems. When nitrification occurs uncontrollably in the distribution system, the biological stability of the distribution system is disrupted, which can cause a number of water quality problems (Rittmann and Snoeyink, 1984). The autotrophic bacteria responsible for nitrification are abundant in many source waters, and can grow readily in distribution systems if ammonia and oxygen are available. The occurrence of nitrification in distribution systems is common and has been well-documented (Rittmann and Snoeyink 1984; Odell et al., 1996; Fleming et al., 2005). For example, biological activity has been shown to promote corrosion of some metals (Lee et al., 1980; Bremer and Wells, 2001). In the case of nitrifying bacteria, the corresponding pH drop associated with the biological oxidation of ammonia directly impacts the corrosion of distribution system. In addition, the nitrifying bacteria support the development of undesirable heterotrophic biofilms by supplying organic carbon substrates; these biofilms

produce metabolic byproducts that adversely affect the taste and odor of the water (Suffet et al. 1996). Incomplete nitrification of ammonia can result in increased levels of the toxic nitrite ion. Because the United States Environmental Protection Agency's (U.S. EPA) maximum contaminant levels (MCLs) apply at the entry point into the distribution system rather than within the distribution system, monitoring of contaminants such as nitrite and nitrate are normally not conducted at the consumer's tap. In addition to this, the removal of ammonia before chlorination decreases the formation of undesirable chlorinated by-products.

Filtration on biological granular activated carbon (BAC) proved to be efficient in removing biodegradable dissolved organic carbon (BDOC) and this process can also be used to simultaneously remove ammonia by biological oxidation. The main objective of this study is to study the applicability of biological activated carbon (BAC) in drinking water treatment for the Ömerli raw water.

In the first part of the study, batch experiments were conducted to determine the optimum conditions and materials to be used in subsequent continuous-flow biofiltration experiments. Based on this, the objectives of the first part were as follows:

- to investigate the relationship between the ozone dosage and the BDOC amount. Finding the optimum ozone dosage to achieve the maximum biodegradability is important in biofiltration since it generally results in higher biodegradation.
- to investigate the adsorption of NOM in Ömerli water onto four types of granular activated carbons.
- to investigate the desorption of NOM from the activated carbons.

In the second part of the study, continuous-flow biofiltration experiments were performed in order to investigate:

- the differences in bio-removal efficiencies of chemically and thermally activated carbons.
- the effect of ozonation on biodegradation efficiency.

- nitrification performance in chemically activated and thermally activated BAC columns.
- the microbial diversity of nitrifiers in these BAC columns.

4. MATERIALS AND METHODS

The main objective of the study is to investigate the applicability of biological activated carbon (BAC) in drinking water treatment for the Ömerli raw water. In the first stage of the experiments, batch adsorption and desorption were conducted to predict the results in continuous-flow GAC columns and determine the most suitable GAC types for biofiltration. In the second stage, continuous-flow biofiltration experiments were done by selecting two of the four tested GAC types. Finally, the last phase consisted of application of molecular methods to bacteria which colonized GAC surfaces.

4.1. Batch Adsorption and Desorption Experiments

4.1.1. Reagents and Materials

Organic free distilled water was used for the cleaning of all glassware and ultrapure water was used for the preparation of reagents used in the experiments. Ultrapure water produced with a Sartorius water purification system, which treated deionized water with ion exchange and UV disinfection. The TOC of the distilled water was less than 0.35 mg/L and that of ultrapure water was less than 0.15 mg/L in all cases.

Raw water samples were supplied from the Ömerli reservoir, which supplies water to some regions in Istanbul at a rate of 1,000,000 m³/d. According to the year round measurements, the dissolved organic carbon (DOC) and total organic carbon (TOC) of the source varied between 3.5 – 5.8 mg/L and 4.1 – 6.0 mg/L, respectively. The raw water samples were filtered as soon as they arrived in the laboratory. Filtering through 2 µm cellulose acetate filters was done to exclude organisms like protozoa and algae.

4.1.1.1. Indigo Reagent. Liquid phase ozone concentration was determined by the indigo method (Standard Methods, 1995). This method uses the decolorization of indigo upon its reaction with ozone at pH below 4. The decrease in absorbance is linear with increasing concentration. The decolorization of indigo can be detected at 600nm.

Preparation of indigo reagent was done with potassium indigotrisulpanate supplied from Riedel-de Haen Company. Indigo stock solution was prepared according to Ozone (Residual) / Indigo Colorimetric Method stated in Standard Methods, Method No: 4500. The method is quantitative, selective and simple; it replaces methods based on the measurement of total oxidant.

For the preparation of indigo stock solution, 500 mL distilled water and 1 mL concentrated phosphoric acid were added to a 1 L volumetric flask. With stirring, 770 mg potassium indigo trisulfonate, $C_{16}H_7N_2O_{11}S_3K_3$ was added and filled to mark with distilled water. The stock solution is stable for 4 months when stored in dark.

Indigo reagent was prepared by taking 200 mL of the indigo stock solution, 10 g sodium dihydrogen phosphate (NaH_2PO_4) and 7 mL of concentrated phosphoric acid and diluting it to 1L flask. When the absorbance of the solution decreases to less than 80 % of its initial value, it is prepared fresh.

4.1.1.2. Total Organic Carbon Standard. A 1000 mg/L Potassium Hydrogen Phthalate (KHP) TOC analyzer calibration standard was obtained from Tekmar-Dohrmann. Proper dilutions were made with ultra pure water obtained Merck Company to construct the calibration curve from the stock solution. An example TOC calibration curve was presented at the Appendix A section.

4.1.1.3. Granular Activated Carbon. All activated carbon samples used in this study were obtained from Norit Company, the Netherlands and the samples were used without pretreatment. CAggran, which has a very open (meso and macro) pore structure type, is a wood based granular activated carbon. It has been produced by chemical activation using phosphoric acid. Row 0.8 Supra is a peat-based and chemically activated extruded activated carbon type. GAC 1240 and Hydrodarco 4000 are produced by heat activation and are both coal-based GAC grades. Physicochemical characteristics of different virgin GAC grades are summarized in Table 4.1.

Table 4.1 Properties of activated carbon grades used in the study

Activated Carbon	Row Supra	GAC 1240	HD 4000	CAgran
Origin	Peat	Coal	Lignite coal	Wood
Physical Form	Extruded	Granular	Granular	Granular
Activation Method	Thermal	Thermal	Thermal	Chemical
Total Surface Area (BET) (m ² /g)	1150	1175	700	1400
Apparent Density (g/L)	390	480	400	225
Moisture (%)	5	2	8	12
Iodine Number (mg/g)	1050	1075	600	850
Molasses Number	350	230	330	165
Total pore volume (cm ³ /g)	1.08	0.83	1.00	1.75
Micro pore ($\phi < 2\text{nm}$) (cm ³ /g)	0.34	0.35	0.15	0.26
Meso pore ($\phi < 2\text{-}50\text{nm}$) (cm ³ /g)	0.24	0.22	0.50	0.60
Macro pore ($\phi > 50\text{nm}$) (cm ³ /g)	0.50	0.26	0.35	0.89

4.1.2. Analytical Methods

4.1.2.1. Ozone Measurement. Liquid phase ozone concentration during the ozone demand experiments was determined by the colorimetric method (Standard Methods, 1995). This method uses the decolorization of indigo upon its reaction with ozone at pH below 4. The decrease in absorbance is linear with increasing concentration. The decolorization of indigo can be detected at 600 nm. During the experiments, sample was continuously drawn at a rate of 19.6 mL/min from the reactor by a peristaltic pump, while another pump was drawing indigo reagent at the same time. Indigo reagent and the ozonated solution tubings were connected to single tubing by a tee and the absorbance of the mixture was measured by the spectrophotometer.

An oxygen-feed corona discharge ozone generator (PCI Model GL-1 type) was used for the ozonation of the raw water samples. The ozone gas was sparged into reactor using 10 cm ceramic porous type commercial ozone diffuser. Teflon tubing was used for all the connections from the ozone generator to the reactor vessel. The ozone generator produces 787.5 mg O₃/min ozone for 32 SCFH oxygen flowrate and 100 % ozone output. The rate of ozone applied in the experiments was 4 SCFH oxygen flowrate and 5% ozone output.

Calculation of the concentration of ozone in the liquid phase is based on spectrophotometric procedure and the formula used for this procedure is given in

$$mgO_3 / L = \frac{35 \times \Delta A}{f \times b \times V} \quad (4.1)$$

where:

ΔA = difference in absorbance between sample and blank

b = path length of cell, cm (2.5 cm)

V = volume of the sample, mL (19.6mL)

$f = 0.42$

The factor f is based on a sensitivity factor of 20,000 / cm for the change of absorbance (600 mm) per mole of added ozone per liter. It corresponds to an absorption coefficient for aqueous ozone, $\epsilon = 2950/M.cm$ at 258 nm.

4.1.2.2. Total Organic Carbon Measurement. The measurement of TOC and DOC is critical for the outcome of this study. TOC and DOC were determined by the combustion method (Standard Methods 5310 B) using a Teledyne-Tekmar Apollo 9000 model TOC analyzer. The only difference between the TOC and DOC measurements is that, in case of DOC determination, the sample was passed through a 0.45 μ m syringe driven filter (Millipore). All samples were acidified with 21% phosphoric acid by the analyzer automatically to reduce the pH to less than 2.0 and purged to remove inorganic carbon as

CO₂. Carbon in the sample is first converted to CO₂ by the combustion furnace for TOC analyses. Carrier gas (99.9% pure dry air) then sweeps the dried CO₂ through a nondispersive infrared (NDIR). The gas flow through the combustion tube was 200 ± 10 cc/min. Each sample was analyzed three times. The average RSD of the results was 0.6 %. To ensure the reliability of the results, the blank (distilled water) was introduced prior to the sample analysis and also at regular intervals. Calibration check was also done to check the stability of the TOC analyzer once every week.

4.1.2.3. Absorbance Measurements. Absorbance measurements were carried out at wavelengths 254 and 280 by a Shimadzu UV- 2450 Model UV-Visible double beam spectrophotometer with 1cm quartz cell. Measuring the UV absorbance of DOM solutions in the range of 254-280 nm reflects the presence of unsaturated double bonds or π - π electron interactions such as in aromatic moieties of DOC (Lawrance, 1980). From the results of the UV₂₅₄ (m⁻¹) measurements the SUVA can be calculated. The stability and internal consistency of the measurements were checked by analyzing blank water samples every 4-5 measurements. The sample cells were washed and cleaned periodically to prevent accumulation of residues on the cell walls and their interference with the measurements.

The UV absorbances at wavelengths of 254 and 280, which are the wavelengths commonly employed for natural waters, were measured in fixed wavelength mode (Kitis, 2001). The same wavelengths were chosen in the studies of Çeçen, 1999; Çeçen and Aktaş, 2001. It is generally observed in natural waters that UV absorbance peaks around 254 nm and decreases with increase in wavelength.

4.1.3. Experimental Procedures

4.1.3.1. Determination of Optimum Ozone Dosage. Raw water samples were ozonated at different O₃/DOC ratios in order to find the optimum ozone that produces the maximum amount of BDOC. In this study, the ozone application rate was kept constant at 4.92 mgO₃/min. The liquid volume in the reactor was kept constant in all experiments. Higher dosages were maintained by extending the time of ozone application.

4.1.3.2. BDOC Measurement. BDOC was measured by the method originally developed by Servais et al. (1987). The sample solution was sterilized by filtration through a 0.45 μm pore size membrane filters (Millipore) and raw water which is filtered through a 2 μm pore size filter was added as inoculum. The solution was then incubated at 20°C in the dark for 28 days. Samples were taken to check the rate of decrease in the TOC content every two days. The BDOC amount corresponds to the difference between the initial and final concentration of DOC during 28 days of incubation. The loss of DOC represents the amount of DOC which is mineralized by heterotrophic biomass. It should be noted that TOC may increase slightly after a certain time as a result of bacterial lysis.

4.1.3.3. Determination of Point of Zero Charge (pH_{PZC}). The most commonly examined feature of surface chemistry is the pH of the point of zero charge (pH_{PZC}), which is the pH at which the GAC surface carries a net charge of zero. Accordingly, for solution pH values greater than pH_{PZC} the activated carbon carries a net negative surface charge, while for pH values below pH_{PZC} the carbon carries a net positive surface charge.

pH_{PZC} measurements were conducted using a technique analogous to that of Newcombe (1994). In producing the results, all titrations were conducted in duplicate, under nitrogen and at 25°C. Approximately 0.25 mL of 0.05M HCl was titrated into 200 mL of NaCl solution which would bring the pH down to 4. The solution was stirred and bubbled with nitrogen for 50 minutes. Then, the nitrogen bubbler was raised out of solution and fixed so that it remained about 2 cm above the solution. Subsequently, NaOH was added to raise the solution pH to about 10. In the case of blanks, titration was then begun, with sufficient time between 0.01 mL additions of HCl. Titration continued until pH 4.

During the titrations with activated carbon, 0.1 g of GAC was added to the vessel after the addition of base. The solution was stirred for 30 minutes to allow the carbon to equilibrate with the solution. 0.05 mL of HCl additions continued until the solution pH reached 4.

The relative surface charge was determined from the difference between the surface titration curves and the blank curves using the equation:

$$|\sigma_0| = n/m \quad (4.2)$$

where

$|\sigma_0|$ = magnitude of relative surface charge (mmol/g)

n = difference between the blank and activated carbon curves (mmol)

m = mass of GAC (g).

The relative surface charge data of GAC were plotted with respect to pH at two electrolyte concentrations (0.1 M and 0.01 M NaCl). The pH at which the two curves intersect is considered to be the pH at which the absolute charge on the GAC surface is zero (pH_{PZC}), since this is the only point where the surface charge is independent of the electrolyte concentration (Newcombe et al., 1993). The curves are then shifted with respect to the y-axis until the surface charge at pH_{PZC} is situated at zero surface charge. The resultant plot gives the absolute surface charge with respect to pH.

4.1.3.4. Surface Acidity of GAC. Acidic surface functional groups on GAC surface were characterized with the alkalimetric titration technique (Boehm, 1966). 200 mg of GAC samples were contacted with 25 mL of base solutions of different strengths (0.05 N NaHCO_3 , Na_2CO_3 , and NaOH) for 48 hours. After equilibration, the carbon samples were separated from solution by centrifuging. 0.05 M HCl was used to titrate under nitrogen the unreacted or unadsorbed base remaining in solution. Titration to different end point pH values allowed the characterization of different functional groups on GAC surface (Table 4.2). The amount of base reacted with GAC surface was calculated by taking the difference between the amounts of acid titrant consumed to titrate the remaining base in a sample and in a control vial (without GAC) to the same end point pH.

Table 4.2 Potentiometric endpoint pHs of alkalimetric titrations

Base Solution	Potentiometric End Point pHs	Acid Strength, pKa	Surface Functional Group(s)
NaHCO ₃	4.40	<6.40	Carboxylic (Strong)
Na ₂ CO ₃	4.40	6.40-10.30	Carboxylic (Weak)
NaOH	8.30	10.30-15.70	Phenolic

4.1.3.5. NOM Charge. Titration of NOM was conducted by the technique of Newcombe and Drikas (1997). A known solution of 200 mL NOM was equilibrated in 0.01 M NaCl for 50 minutes at a constant temperature of 25 °C. All titration experiments were done using nitrogen gas to prevent dissolution of gases as well as purge the dissolved carbon dioxide. A known amount of 0.05 M NaOH was added to raise the pH and NOM titration was performed down to pH 3 using 0.01 M of HCl. A blank titration was also done under the same conditions. The difference between the blank curve and the NOM titration curve gave the total titratable acid groups present per milligram of NOM between pH 9 and 3. This pH range is considered to reflect the ionization of carboxyl groups (Collins et al., 1986).

As the NOM was already in solution, the initial degree of ionization was unknown. As this is a difficult value to determine, an approximation must usually be made. From a work by Newcombe et al. (1994), it was assumed the NOM would be fully protonated (degree of ionization, $\alpha=0$) at pH 3. This was taken as the starting point of the titration for both the blank and the NOM solution. It is likely that there will be some degree of ionization of NOM at this pH, however, as the main aim of the titration is to determine the charge behavior of the NOM between pH 3 and 9, the errors caused by the assumption that $\alpha=0$ at pH will be neglected. One major error involved in this method is the accuracy of the pH determination. The titration curves display an extended plateau around pH 3, therefore a small error in the pH value will cause a substantial error in the calculated volume of base required to reach a particular pH.

4.1.3.6. Adsorption Experiments. Isotherm experiments were conducted using the variable-dose completely mixed batch reactor (CMBR) bottle point technique at a constant temperature (25°C) using a mechanical shaker in a water bath (GFL 1083). The equilibration experiments at a chosen GAC concentration (75 mg/L) indicated that an adsorption time of 24 h was sufficient to reach equilibrium for all GAC types tested. Therefore, 24 h of mixing was selected for all batch isotherm experiments. Adsorption isotherms were conducted using GAC within the range of 5 – 10,000 mg/L for water samples. In spite of the fact that this is an unrealistically high range, this dosage was chosen to estimate the amount of nonadsorbable DOC. Duplicate adsorption isotherm experiments were conducted at the same conditions for each GAC sample and water. The chosen GAC types were equilibrated with water samples in 300 mL glass flasks which were sealed with screw capped glass caps under oxic conditions (200 mL solution volume). 24 different GAC concentrations were used to perform the adsorption test for each carbon and water. One flask was used as a blank (without GAC) in order to estimate the biodegradation that may take place over the course of experiments. Since the equilibration experiments lasted for 24 h, the effect of biodegradation was limited. The loss of DOC due to biodegradation during adsorption experiments was less than 1.5% in ozonated water samples and less than 1% in raw water samples. Isotherms were conducted at the original pH of natural water samples without buffer addition. Final pH values after equilibration of GAC with water were between 7.2-7.8. Then, the water samples were analyzed for DOC, UV absorbance at 254 and 280 nm (UV₂₅₄ and UV₂₈₀), pH and BDOC.

The Freundlich equation given below is widely used for activated carbon applications:

$$q = K_f \times c_e^{1/n} \quad (4.3)$$

where

q= adsorption capacity of activated carbon (mg TOC adsorbed / g activated carbon)

c_e=equilibrium TOC concentration

K_f and 1/n are Freundlich constants (Freundlich exponent and slope)

Freundlich Isotherms

If the data fits the model, plotting $\log(q)$ versus $\log(c_e)$ yields a straight line with a slope of $1/n$ and $\log(K_f)$ is the value of the $\log(q)$ at $c_e=1$ ($\log(c_e)=0$). The constant, K_f , in the Freundlich equation is related primarily to the capacity of the adsorbent for the adsorbate, and $1/n$ is a function of the strength of the adsorption (Snoeyink, 1990). For fixed values of c_e and $1/n$, the larger the value of K_f , the larger the capacity, q . For fixed values of K_f and c_e , the smaller value the value of $1/n$, the stronger the adsorption bond. The value of $1/n$ for the adsorption of most organic compounds by activated carbon is <1 . When $1/n$ is close to 1 (i.e., steep slopes), it indicates a high adsorptive capacity at high equilibrium liquid phase concentrations and rapidly diminishing capacities at lower equilibrium concentrations. When $1/n \ll 1$ (flat slopes), the capacity tends to be independent of c_e , and the isotherm becomes horizontal. In this case, the value of the q is essentially constant. If the value of $1/n$ is large, this means that the adsorption bond is weak, and the value of q changes markedly with small changes in c_e .

4.1.3.7. Desorption Experiments. Desorption isotherms were constructed according to the batch-displacement technique. This technique consists of placing the GAC which was loaded in adsorption experiments into ultra-pure water for a sufficiently long time so that equilibrium was reached between the solid and bulk liquid. The detailed procedure is as follows: After adsorption equilibration, the supernatant was removed. Then, 100 mL of ultra-pure water was added to the flasks which contain the loaded GAC and the mixture was shaken for 24 hours in a constant temperature shaker (25°C) until equilibrium was reached. The pH of the deionized water was 6.0 ± 0.1 . pH adjustment was not done prior to or during desorption experiments. During the equilibration time desorption took place from the GAC to the bulk liquid. Afterwards, the DOC concentration was measured in the liquid phase. Desorption isotherms were constructed based on the DOC loading still remaining on the GAC surface after desorption; i.e.,

$$q_{des} = \frac{\text{Mass of NOM adsorbed} - \text{Mass of NOM desorbed}}{\text{Mass of GAC}} \quad (4.4)$$

where q_{des} is the DOC loading remaining on GAC after desorption. Mass of NOM adsorbed is the amount of NOM adsorbed onto the GAC during adsorption experiments. Mass of NOM desorbed can be calculated by the following formula

$$\text{Mass of NOM desorbed} = [(c_e)_{des} - (c_0)_{des}] \times V \quad (4.5)$$

where $(c_e)_{des}$ is the equilibrium DOC concentration at the completion of the desorption test, $(c_0)_{des}$ is the DOC concentration of the ultra-pure water and V is the volume of the ultra-pure water (100 mL) in the flask. Then, data for each carbon type were plotted as q_{des} versus $(c_e)_{des}$ and fitted into the Freundlich type isotherm equation.

The loading remaining on the GAC surface has also been used for the construction of desorption isotherms in the studies of Aktaş and Çeçen (2006a, 2006b). In the same study, desorption was conducted successively until equilibrium was reached and a succession of desorption steps produced a desorption isotherm. However, in the current study a succession of desorption steps is not possible due to low equilibrium concentrations observed after desorption.

Process Water for Adsorption and Desorption Experiments

Adsorption and desorption studies were conducted with the following water samples (Figure 4.1).

1. Raw water samples taken from the Ömerli Reservoir

2. Ozonated Ömerli Water (2mg O₃/ mg DOC):

Raw water samples were first ozonated at different O₃/DOC ratios. Ozonation was done in a 20 L bottle and the ozone application rate was kept constant at 4.92 mgO₃/min. It was possible to extend ozonation time and increase the ozone dose per DOC as desired. The ozone dose which produced the maximum amount of BDOC was denoted as optimum ozone dose and the water sample (as specified in the Results section) was named Ozonated Ömerli water.

3. Biologically treated Ömerli water:

This water contained nonbiodegradable DOC only: The biodegradable portion of organic matter was removed from raw water by application of the BDOC procedure. The leftover DOC at the end of 28 days of incubation was assumed to consist of nonbiodegradable organic matter only.

4. Ozonated - biologically treated water:

Raw water was first ozonated at the optimum ozone dosage and then the biodegradable portion in the ozonated water was removed by application of the BDOC procedure.

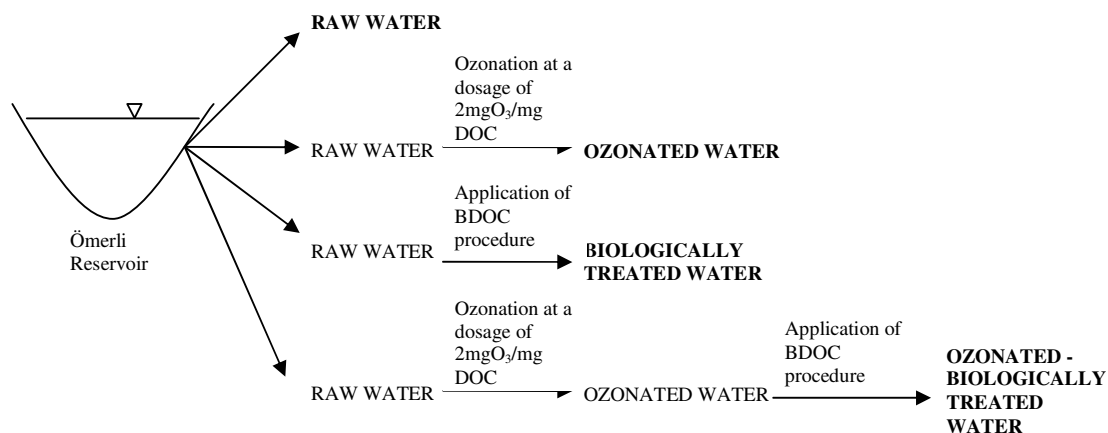


Figure 4.1 Processes applied to the water samples prior to adsorption and desorption experiments

Figure 4.2 shows the overall processes applied to raw water samples in the scope of adsorption experiments.

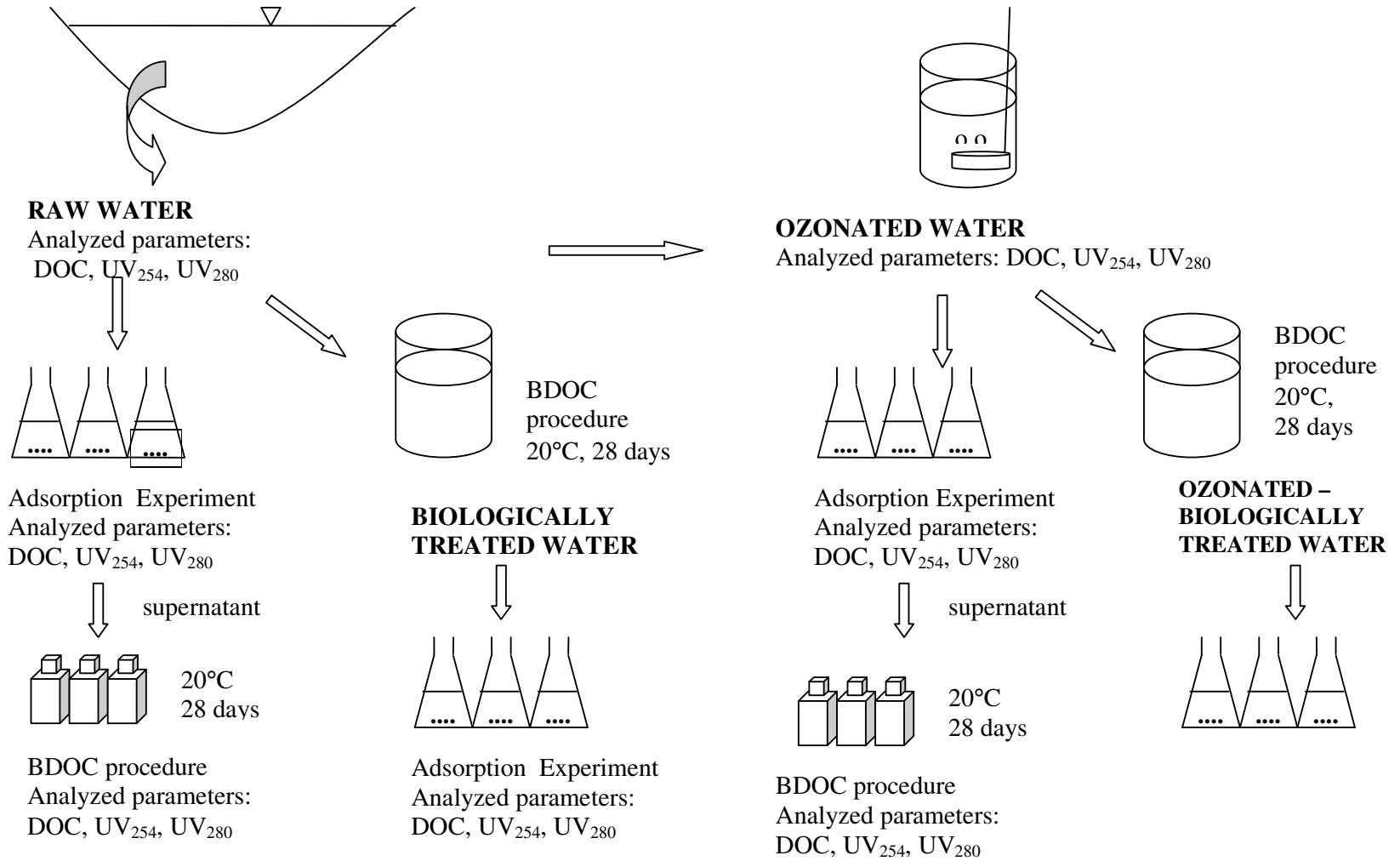


Figure 4.2 The overall adsorption experiments

4.2. Optimization of BDOC Measurement

Biodegradable dissolved organic carbon (BDOC) measures the amount of dissolved organic carbon (DOC) that is biodegradable. The original batch BDOC method (Servais et al., 1985) uses the inoculum that originates from the same water sample (indigenous inoculum). To satisfy the requirement, the water sample is filtered and inoculated with the sample itself. Details of the original BDOC measurement protocol were provided in Section 4.1.3.2. Modifications to improve the BDOC measurement technique is the topic of this section.

4.2.1. Reagents and Materials

BDOC measurement modifications were tested for raw water and ozonated water samples as well as acetate solutions at different concentrations.

4.2.2. Analytical Methods

4.2.2.1. BDOC Measurement. BDOC was measured in duplicate for each sample and inoculum tested which is similar to the method developed by Servais et al (1987). A brief description of the method is as follows: The raw water and ozonated water samples were filtered through a 0.45 μ m glassfiber filter paper (Schleicher & Schuell, Germany), measured for DOC and inoculated with seed at different proportions.

Instead of using the water sample itself as an inoculum, the bacteria that grow on a suspended growth system were used. The indigenous bacteria in Ömerli water were enriched by supplementing oxygen and feeding the system formerly with glucose and acetate and later with Ömerli water only. Therefore the suspended growth system contains bacteria that originate from the reservoir and are acclimated to both readily and slowly biodegradable DOC by producing special enzymes. Different seeding ratios like 1:100, 1:250 and 1:500 were tested to determine the optimum seed ratio. The inoculum was also tested on a readily biodegradable substrate (acetate). Acetate solutions at different concentrations (1 mg/L, 2.5 mg/L and 5 mg/L Acetate-C) were prepared. Necessary nutrients like MgSO₄, CaCl₂, FeCl₃ and phosphate buffer were used in amounts that were

added in the Biochemical Oxygen Demand (BOD) experiments (5210B, Standard Methods). The mixture was incubated at 20°C in an incubator (TS-606-G, WTW) for 28 days. DOC was measured again after incubation. The difference between the first and 28th day DOC reading was BDOC. Samples were also taken at regular intervals to see the trend for BDOC formation with respect to days.

4.3. Continuous-Flow Operation of BAC columns

Continuous-flow BAC column experiments were conducted in lab-scale columns to facilitate comparisons to full-scale adsorption systems.

Ömerli reservoir water was filtered as soon as it arrived to the laboratory through 5µm polypropylene cartridge filter. Polypropylene filters can be used for DOC determinations and were found not to leach any contaminants that cause erroneous DOC measurements (Karanfil et al, 2003). Approximately 120 L of water is sent to the laboratory from the treatment plant at one time. This corresponds to nearly 1 week of supply to the columns. In order to prevent biodegradation, water samples were kept at 4 °C till they were pumped to the columns.

4.3.1. Experimental Setup

4.3.1.1. Batch Suspended Growth Culture. For four months prior to the start up of columns, the bacteria existing in the Ömerli water were enriched by adding readily biodegradable substrates (acetate and glucose) and by supplying air in a four liter batch reactor. During this enrichment, fresh Ömerli water was added to the reactor every day to supply the necessary nutrients as well as to enable bacteria to produce specific enzymes for biodegradation of this DOC. The reactor was also fed with 0.6 mg/L NH_4^+ -N to enrich nitrifiers. When the volatile suspended solids (VSS) concentration in the reactor reached 140 mg/L, the acetate / glucose supplementation was stopped and the reactor was only fed with Ömerli water. This way, the reactor was run for about three months and the VSS concentration dropped to 70 mg/L due to endogenous decay. At that time, the bacteria were contacted with GAC in a mechanical shaker overnight and the mixture was transferred to the columns. Figure 4.3 shows the batch reactor used to enrich Ömerli water.



Figure 4.3 Batch reactor used to enrich the microorganisms in Ömerli water

The batch reactor operation was continued until the column operation was stopped, because the culture from this reactor was used as a seed for the BDOC measurement.

4.3.1.2. Column Setup. For the determination of the most suitable column depth, diameter and flow rate, a detailed summary of studies have been compiled in literature. Table 4.3 shows the summary of studies performed about biological drinking water filters. In the light of the studies compiled the following set-up was selected. (Table 4.4).

Table 4.3 Summary of studies examining biological drinking water filters

Study	Media Type	Diameter (cm)	Column Depth (cm)	EBCT (min)	Hydraulic Load	Biofilter Development	Ozone Dose (mgO ₃ /mg DOC)	Temperature (°C)	DOC _{inf} (mg/L)
Grabinska et al, 2004	Charcoal	2	100	60	1 m/h	57 days	2 mg O ₃ /L		8.6
Nishijima et al., 1998	GAC	6	100	15			2.5	20	2
Kameya et al., 1997	GAC	5.1	91	6	9 m/h			15	
Kim et al,1997	GAC		3	15			3 mg O ₃ /L	16	2.3
Asami et al, 1999	GAC	10	70	15	2.44 m/h	2 months			2-3
Sholz and Martin, 1997	GAC	12	30	15	1.2 m/h				
Yavich et al, 2004		25	40	15-20	0.01-0.015 m/h	4 months	<1		6-8
Nishijima and Speitel, 2004	GAC	1.4	25	15	9.4 m/h	10 days (w/inoculum)	1-2	25	8
Carlson and Amy, 2001	Anthracite		210	3.2-6.4	5-9.7m/h	60 days	1		
Chaiket et al., 2002		7.6	51	5	7.3 m/h				
Moll et al., 1999	Sand	2.54	40	7	3.6 m/h	1 month	1.3	5-20-35	

Table 4.4 Biological Activated Carbon (BAC) set-up in this study

Number of Columns	4
GAC grades used	CAgran, Norit 1240
Column Height	1 m
Column Diameter	2 cm
Hydraulic Loading	1.67 m/h
GAC depth	50cm

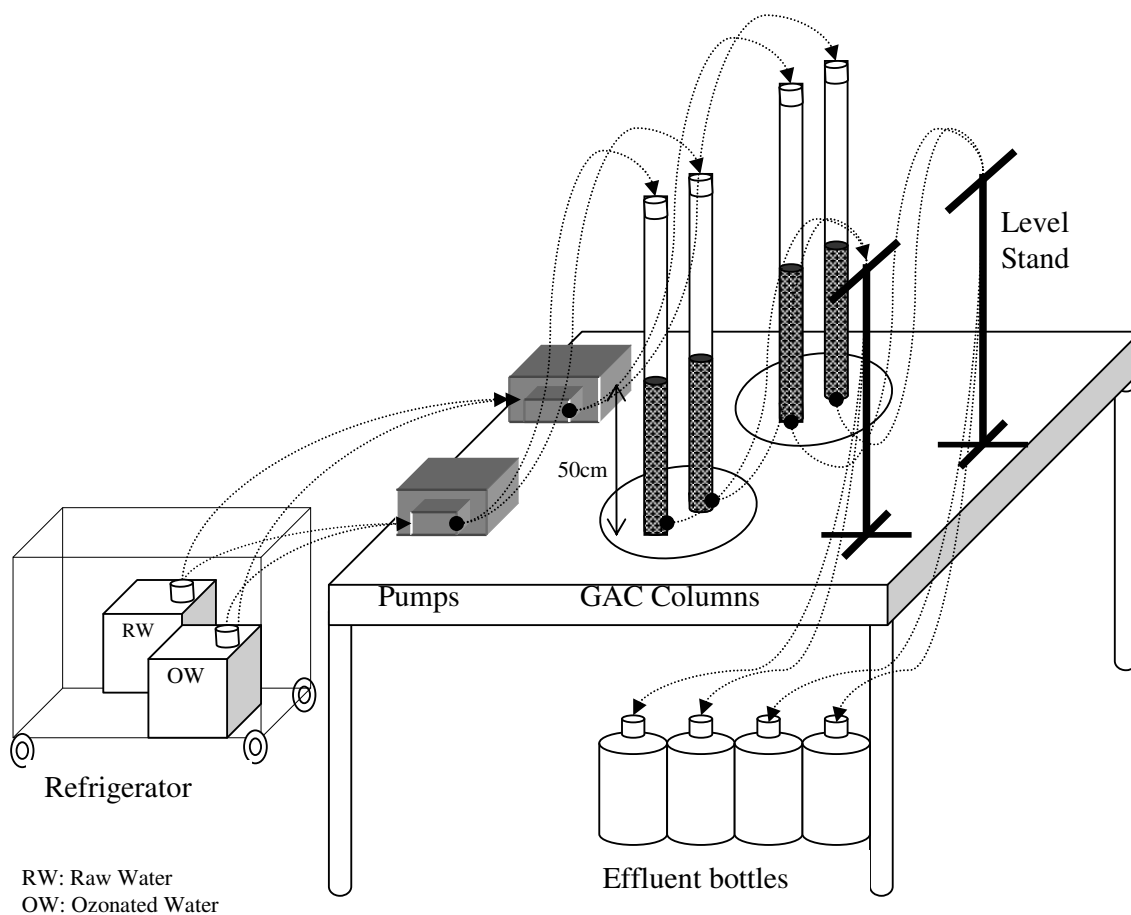


Figure 4.4 Experimental setup used in biofiltration experiments

The scheme of the set-up is shown in Figure 4.4. The experimental setup is made of plexiglass. Three different ports located at 25, 50 and 75 cm below the top level of the

column was provided for water sampling. In addition to this, GAC sampling ports were also placed next to water sampling ports. Stainless steel valves that were covered with filters (in order to prevent GAC leakage when water sampling) were placed on the water sampling ports. The columns use 50 cm of the 1 m depth. This is because when backwashing is required due to bacteria clogging, the empty part can provide space for media expansion. The empty bed contact time (EBCT) in the columns is 18 minutes.

Influent water was pumped to the column using two peristaltic pumps (Watson Marlow, 323S). For a typical column the influent flow rate was 10.2 mL/min, which is equivalent to a hydraulic loading of 1.67 m/h. All columns were operated in down-flow mode.

The columns were operated in a temperature-controlled room at 25 °C. Two of the four tested GAC types (Section 4.1.1.3.) were used in continuous-flow biofiltration experiments. Each GAC column was operated with both raw water and ozonated water in parallel at separate columns. Therefore, there are four columns in the whole experimental set-up. Two of them receive raw water, and the other two receive ozonated water. The raw water is ozonated at a rate of 2 mg O₃ /mg DOC at laboratory conditions. This dosage was found to produce the maximum amount of BDOC without mineralizing the DOC by more than 5 %. This will be explained later in the “Results and Discussion” section. After ozonation the water was purged with oxygen gas to promote the desorption of ozone gas, and allowed to stand one hour for self decomposition. Then the ozonated water container was placed into the refrigerator and left there overnight prior to column test.

GAC samples were saturated with distilled water overnight. Prior to transferring the GAC, the column was partially filled with distilled water to keep the GAC particles submerged during column assembly and to prevent entrapment of air within the GAC bed. Hydraulic arrangements were done by the use of level stand in order to guarantee at least 10 cm of free water height above the media. This way, even in the situation of any pump failure or electricity blackout in which water cannot be pumped, the water level was at least 10 cm above the media.

The effluent bottles contain the effluent water. The weight of the bottles was measured every day in order to check the flow rate of each pump.

Prior to starting the column operation, in order to accelerate the bacterial activity within the filter, the enriched culture of bacteria from Ömerli water was established and this culture was contacted with the GAC overnight. Details of this process are presented in 4.1.1.1. Therefore, from the first day of the column operation the columns were biologically active.

The hydraulic loading was adjusted to 1.67 m/h in order to achieve laminar flow within the media. The influent and the effluent water were analyzed for DOC, $\text{NH}_4^+\text{-N}$, $\text{NO}_2\text{-N}$, $\text{NO}_3^-\text{-N}$, Total Nitrogen, pH, UV_{254} , UV_{280} and BDOC every day. 2h- composite samples were collected in the influent. The photos of experimental setup are shown in Figures 4.5 and 4.6.



Figure 4.5 BAC setup

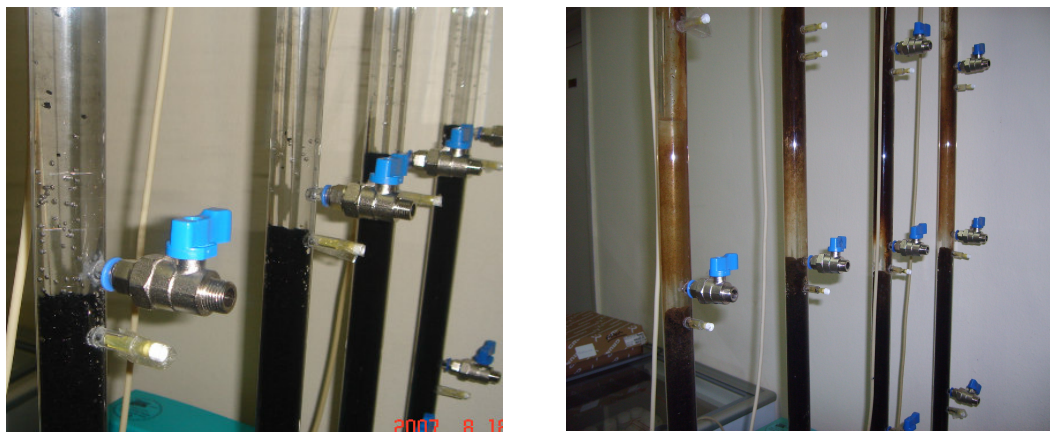


Figure 4.6 View of columns at the first day and at 187th day of operation

4.3.2. Experimental Methods

Experimental analyses and their measurement methods are listed on Table 4.5.

Table 4.5. Experimental analyses and their measurement methods

Analysis	Method
NH_4^+ -N	Method 4500-NH ₃ C (Nesslerization Method) in Standard Methods (APHA, AWWA, WEF, 1998)
NO_2^- -N	Diazotization Method (Hach Method 8057)
NO_3^- -N	Cadmium Reduction Method (Hach Method 8192)
PO_4^{3-}	Amino Acid Method (Hach Method 8178)
Total Nitrogen	Chemiluminescence Detector of the TOC analyzer (Apollo 9000)

4.3.2.1. Dissolved Oxygen and pH Measurements. The dissolved oxygen concentrations and pH were measured by using HACH HQ 40d Multimeter.

4.3.2.2. Preparation for DOC Measurements. Water samples were passed through 0.45 μm syringe driven PVDF filter (Millipore). In order not to leach any organic material into the filtered water, 15 mL of deionized water was passed through the filter. Then 5 mL of sample was passed prior to the sample filtration.

4.4. Molecular Microbiological Studies

4.4.1. Sample Collection and Preparation

In this study, the diversities of nitrifying species in BAC columns were monitored and analyzed by using fluorescence in situ hybridization (FISH), slot-blot hybridization, polymerase chain reaction (PCR) and denaturing gradient gel electrophoresis (DGGE) techniques. These results were compared and evaluated with the data of real-time PCR, cloning and DNA sequencing data to clarify the function of nitrifying population. The experimental procedure followed in the identification of microorganisms is given in Figure 4.7.

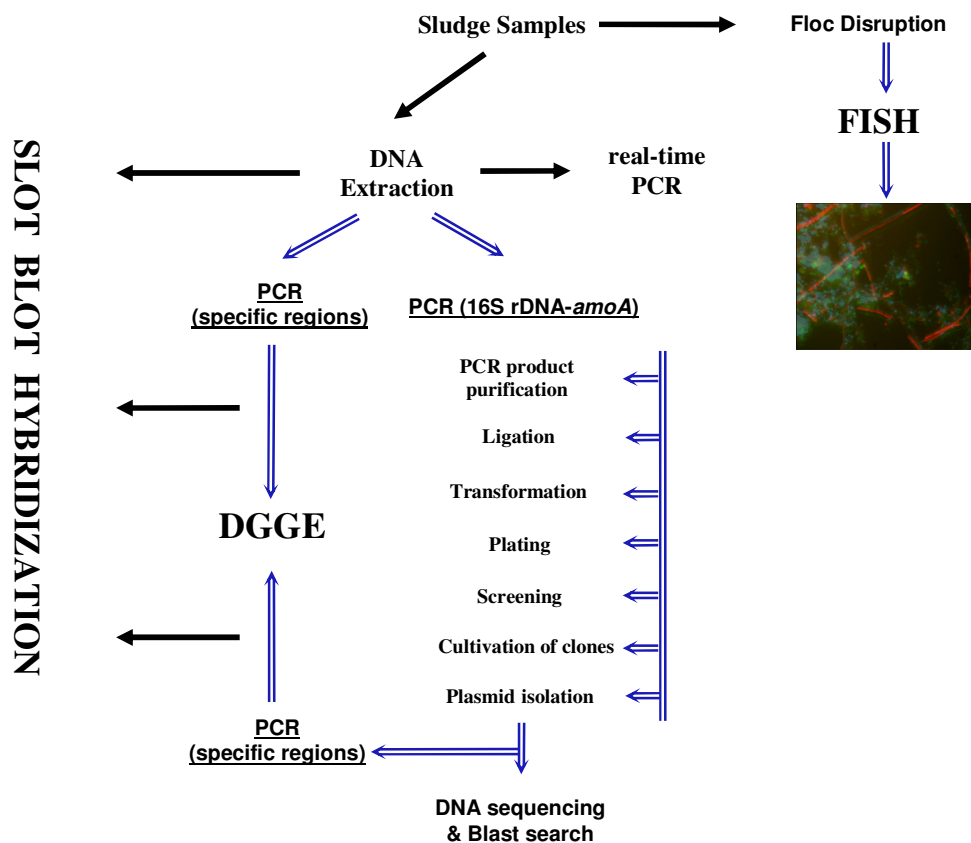


Figure 4.7 Procedures for molecular identification.

After biological activated carbon samples were taken from the columns, FISH fixation and DNA extraction were done immediately. Extracted DNA samples and fixed cells were stored at -20°C. For identification of microbial communities in the columns, samples were collected at different time periods. At Day 0, sample was taken from the batch culture which is used for bacterial enrichment. At Day 125, samples were taken from the each BAC column. At Day 220, GAC samples were taken from each port of the columns.

4.4.2. DNA Extraction

A lot of DNA isolation protocols are available and almost every study uses its own method for extracting DNA. In all of them bacterial cells have to be lysed to release DNA. The cell lysing can be done chemically, with enzymes or mechanically using bead-beating to damage the cell wall. When the microbial DNA is released, DNA-dissolving solutions and/or DNA-binding materials are used to isolate DNA from other compounds in the solution. In the last step DNA is precipitated, collected and dissolved in water or buffer.

The FastDNA[®] SPIN kit (Q-BIOgene) protocol, which is the basis of our DNA extraction procedure, is an effective and widely accepted DNA isolation technique for many applications. The kit comes complete with all buffers and reagents required for DNA extractions. However, in our study the pellets were mechanically bead beaten for 10 s at maximum speed (Mini BeadBeater-8, Biospec Products) for DNA isolation instead of FastPrep Instrument. A modified FastDNA protocol is described that adds several simple steps (0.6 g zirconium/silica beads instead of Lysing Matrix A) to the procedure, resulting in removal of amplification inhibitors (Hermansson and Lindgren, 2001).

Microorganisms in samples (1 mL) were transferred to 2 mL eppendorf tubes using automatic pipette. The samples were centrifuged and the supernatant was discarded. 1000 µL TE buffer (10 mmol/l Tris/HCl, 1mmol/l EDTA, pH 8.0) and approximately 0.6 g zirconium/silica beads (diameter 0.1 mm Biospec Products Inc., Bartlesville, OK) were added to the samples. The cells were disrupted using FastPrep-24 Instrument (MP Biomedicals) for 10 s at maximum speed for DNA isolation. The supernatant was separated by centrifugation at 14000 rpm for 10 min. Subsequently, 600 µL of Binding

Matrix (Bio 101) was added and the tubes were incubated at room temperature for 5 min. The matrix pellet was spun for 1 min and the supernatant was discarded. The pellet was resuspended gently with 500 µl SEWS-M solution (Bio 101). DNA of binding matrix was eluted by gently suspending in 100 µl DES followed by a 2-3 min incubation. It was spun 1 min at 14000 rpm and supernatant was transferred to a new tube. The isolated DNA was used for PCR after judging the quality of the extract by agarose gel electrophoresis and ethidium bromide staining.

Agarose gel electrophoresis separates DNA fragments according to their size. To pour a gel, agarose powder 0.8% (wt/vol) was mixed with 1 x TAE (Tris-acetate-EDTA) electrophoresis buffer to the desired concentration and then heated in a magnetic stirrer until completely melted. Most commonly, ethidium bromide (final concentration 0.5 µg/mL) is added to the gel at this point to facilitate visualization of DNA after electrophoresis. After cooling the solution to about 60°C, it was poured into a casting tray containing a sample comb and allowed to solidify at room temperature.

After the gel had solidified, the comb was removed, using care not to rip the bottom of the wells. The gel, still in its plastic tray, was inserted horizontally into the electrophoresis chamber and just covered with 1 x TAE buffer. Samples containing DNA mixed with loading buffer were then pipeted into the sample wells, the lid and power leads were placed on the apparatus, and a current was applied. DNA migrates towards the anode, which is usually colored red. Gel was electrophoresed at 150 V for 40 min. When adequate migration had occurred, DNA fragments were visualized by staining with ethidium bromide. To visualize DNA or RNA, the gel was placed on an ultraviolet transilluminator.

4.4.3. Polymerase Chain Reaction (PCR)

The utility of PCR was examined by amplifying DNA isolated from BAC columns for slot blot hybridization, denaturing gradient gel electrophoresis (DGGE) and cloning. Almost the entire sequences of the 16S rRNA and variable regions of the *amoA* genes were amplified to obtain more accurate phylogenetic information about nitrifying microorganisms. PCR primer pairs used in this study for amplification of DNA isolates are shown in Table 4.6.

Table 4.6 Amplification primer pairs used in polymerase chain reaction (PCR)

Primer	<i>E.coli</i> numbering	Target	Sequence (5' - 3')	Reference
27 for	8-27	16S bacteria	AGA GTT TGA TCC TGG CTC AG	Ficker, 1999
1510 rev	1510-27	16S bacteria	GGT TAC CTT GTT ACG ACT T	Ficker, 1999
<i>amoA</i> -1F	-	<i>amoA</i> forward	GGG GTT TCT ACT GGT GGT	Rotthauwe, 1997
<i>amoA</i> -2R	-	<i>amoA</i> reverse	CCC CTC KGS AAA GCC TTC TTC	Rotthauwe, 1997
<i>amoA</i> -1F clamp	-	<i>amoA</i> forward with GC clamp	CCG CCG CGC GGC GGG CGG GGC GGG GGC ACG GGG GGG GTT TCT ACT GGT GGT	Nicolaisen and Ramsing, 2002

4.4.3.1. PCR Amplification of bacterial 16S rDNA gene. Nearly full-length bacterial 16S rDNA fragments were amplified by PCR with the general bacterial 16S rDNA primers, 27 forward and 1510 reverse. The PCR amplification reaction was performed in a Progene thermocycler (Techne, Cambridge, UK) and the following program was used: pre-denaturation (95°C, 5 min), 30 cycles of denaturation (95°C, 60 sec), annealing (52°C, 90 sec), elongation (72°C, 90 sec) and final elongation (72°C, 10 min). The reactions were subsequently cooled to 4°C. Amplifications were performed in accordance with the manufacturer's recommendations by using 0.5 µM each primer, 1.5 U of Taq DNA polymerase (MBI Fermentas), 1 x PCR buffer, 1.5 mM MgCl₂, 1.25 mM of each dNTP. The template genomic DNA was diluted 10 times, due to humic acid inhibition, and 2 µL was added to a final volume of 50 µL.

After all amplification, PCR products were analyzed on ethidium bromide-stained 1 % agarose gels. No amplified products were observed in the negative control reaction, and expected size (1.5 kb) of amplified products was obtained.

4.4.3.2. PCR Amplification of *amoA* gene. Primers targeting *amoA*-1F and *amoA*-2R (Rotthauwe et al., 1997) of ammonia-oxidizing bacteria from the β-subdivision of the group *Proteobacteria* were used to obtain amplicons of partial *amoA* sequences. PCR amplification of a 491-bp fragment of the *amoA* gene was carried out in a total volume of 50 µL in 0.5-mL PCR tubes. PCR with *amoA* primers was carried out at a cycling regime of 4 min at 95 °C, then 35 cycles of each 1 min 95 °C, 45 s 60 °C, and 1 min 72 °C. Final extension was carried out for 5 min at 72 °C. Amplifications were performed in accordance

with the manufacturer's recommendations by using 0.5 μM each primer, 1.5 U of Taq DNA polymerase (MBI Fermentas), 1 x PCR buffer, 1.5 mM MgCl_2 , 1.25 mM of each dNTP and 2 μL template DNA (10 times diluted). No genomic template control PCR reactions were performed using only water instead of DNA.

4.4.3.3. PCR Amplification of *amoA* genes with GC-clamp for DGGE analysis. For DGGE analysis of *amoA* gene, 50 μL PCR reactions were performed with the primer pairs *amoA*-1F Clamp/*amoA*-2R [35.5 μL dH_2O , 5 μL buffer (100 nM Tris-HCl pH 8.8, 750 mM KCl, 15 mM MgCl_2); 5 μL dNTP (1.25 mM of each dNTP); 1 μL *amoA*-1F Clamp (50 pmol/ μL); 1 μL *amoA*-2R (50 pmol/ μL); 5U Taq DNA polymerase (MBI Fermentas); and 2 μL template. The PCR thermocycling regime using for this PCR was: 92 $^\circ\text{C}$ for 1 min, 35 cycles of 95 $^\circ\text{C}$ for 30 s, 57 $^\circ\text{C}$ for 30 s, 72 $^\circ\text{C}$ for 45 s; the last cycle had a 5-min final extension.

4.4.4. Denaturing Gradient Gel Electrophoresis (DGGE)

DGGE is a gel-electrophoretic separation procedure for double stranded DNA's of equal size but with different base-pair composition or sequence (Muyzer and Smalla, 1998). In principle, the method is sensitive enough to separate DNA's on the basis of single point mutations (Sheffield et al., 1989).

Briefly, the *amoA* genes are amplified using the appropriate primer pair, one of which has a G+C "clamp" attached to the 5' end that prevents the two DNA strands from completely dissociating even under strong denaturing conditions. During electrophoresis through a polyacrylamide gel containing gradient denaturants, migration of the molecule is essentially arrested once a domain in a PCR product reaches its melting temperature. Following staining of the DNA, a banding pattern emerges that represents the diversity of the *amoA* gene sequences.

DGGE of the PCR amplified *amoA* was performed with the BioRad D-Code Universal Mutation Detection System (BioRad) in accordance with Nübel et al. (1996). The PCR product was loaded onto 1-mm-thick 8 % (wt/vol) polyacrylamide (ratio of acrylamide to bisacrylamide, 37.5:1) gels containing a 25 to 55 % linear denaturing

gradient for *amoA* 16S rDNA. Initially high voltage (200 V for 5 min) was applied to the samples to bring the DNA into the gel and then a lower voltage was used for the rest of the run. The denaturing gradient gels were electrophoresed in 0.5 × TAE buffer (40 mM Tris, 20 mM acetic acid, 1 mM Na-EDTA; pH 8.0) at 100 V and 60°C for 15 hours.

Silver-staining and development of gels was performed as described in Sanguinetti et al. (1994). The procedure consisted of an initial pre-stain fixation for 3 min in 10% ethanol, 0.5% acetic acid, staining for 10 min in fixing solution plus 0.2% silver nitrate, washing of gel in water for 2 min and development for approximately 45-60 min in 1.5% NaOH and 0.3% formaldehyde and 80 µg/L sodium borohydrate in deionized water. Following the staining, gels were fixed for a further 5 min and washed in deionized water to provide a permanent record of the experiment. Subsequent to this second fixation, gels were racked for 7 min in 25% ethanol and 10% glycerol preservation solution and covered with porous hydrophilic cellophane. Finally, gels are dried overnight at 37°C.

4.4.5. Cloning and Sequencing

As DGGE gels contain many bands in one lane because of the microbial complexity in BAC columns, cloning and sequencing techniques were used to find out which band corresponded to which species. The phylogenetic analysis of ammonia oxidizing bacteria was started with the purification of PCR products of *amoA* genes using the QIAquick PCR purification kit (Qiagen) prior to cloning. Then, the purified amplicons were ligated into the pTZ57R/T vector (Fermentas) and were cloned in competent *E. coli* JM109 cells using the InsT/Aclone™ PCR Product Cloning Kit (Fermentas) with ampicillin selection and blue/white screening, following the manufacturer's protocol. White colonies were picked up from each cloned sample and reamplified. Subsequently, PCR amplicons of clone inserts were screened by denaturing gradient gel electrophoresis to determine the representative clones for sequencing. The reamplification product was also evaluated by DGGE to verify the purity and correct the mobility of the reamplified product. The reamplified product was compared with the raw samples; it should give one band and match the raw sample.

Before DNA sequencing, the plasmids of selected transformants were purified using the Wizard Plus SV Miniprep DNA purification kit (Promega). DNA sequences were analyzed in SeqLab Sequence Laboratories (Göttingen, Germany). Afterwards, a similarity search, in the GenBank database, with the derived partial *amoA* sequences from the clones, was performed using the BLAST search program available on the internet (www.ncbi.nlm.nih.gov). Sequences were aligned by using the multiple alignment Clustal W programs (Thompson et al., 1994). Neighbor-joining phylogenetic trees were constructed with the Molecular Evolutionary Genetics Analysis package (MEGA version 2.1) (Kumar et al., 2001) with the Jukes-Cantor algorithm and the robustness of the phylogeny was tested by bootstrap analysis with 1000 iterations.

4.4.6. Fluorescence In Situ Hybridization (FISH)

Fluorescence in situ hybridization (FISH) is a microbial method that allows the detection of whole bacterial cells, target groups or species of interest in natural systems via the labeling of specific nucleic acids with fluorescently labeled oligonucleotide probes. Specificity of probe binding to the target site depends on the hybridization and washing conditions. Hybridization probes are added to a defined, stringency determining buffer at saturation concentrations to maximize probe binding. During hybridization the samples are incubated at elevated temperature in an airtight vessel saturated with water and formamide vapors of additional hybridization buffer to avoid concentration effects due to evaporation. The washing step is performed at a slightly higher temperature and serves mainly to rinse off excess probe molecules at conditions that prevent unspecific binding.

In this study, microorganisms in BAC columns were harvested by centrifugation at $14,000 \times g$ for 5 min and each cell pellets were resuspended in 750 μL of a solution containing freshly prepared 4% paraformaldehyde (PFA) in water (Raskin et al., 1994). PFA fixation solution was prepared by mixing 1 drop of 10 M NaOH, 2 g of PFA, and 16.5 mL of 3 x phosphate-buffered saline with 33 mL of ddH₂O. Then PFA solution was heated to 60°C and cooled on ice, the pH was adjusted to 7.2, and finally the solution was filtered through a 0.45- μm -pore-size filter. After preparation of solution, cells were resuspended in PFA by vortexing the preparation for approximately 60 s and then were incubated at room temperature for 4 h or overnight. Next day, cells were recovered by

centrifugation and washed in a solution containing 900 μ L of phosphate-buffered saline (130 mM NaCl plus 10 mM sodium phosphate, pH 7.2). The final cell pellet was resuspended in a solution containing 500 μ L of PBS and an equal amount of absolute ethanol and stored at 4°C.

Fixed cells were spotted on gelatin-coated [0.1% gelatin and 0.01% KCr(SO₄)₂] multiwell glass slides (10 wells/slide; 4 μ l of sample/well) and allowed to dry at room temperature (Raskin et al., 1994). The slides were then dehydrated by immersing them in 50% ethanol for 3 min, in 80% ethanol for 3 min, and then in 100% ethanol for 3 min and finally were air dried.

Table 4.7 Oligonucleotide probes and hybridization conditions applied in this study

Probe	Sequence (5' - 3')	Target site ^a	Target organism(s)	% of formamide ^b	References
EUB338	GCTGCCTCCCGTAGGAGT	16S (338-355)	<i>Bacteria</i> domain	20	Amann, 1990
ALF1b	CGTTCGYTCTGAGCCAG	16S (19-35)	<i>αproteobacteria</i>	20	Manz, 1992
BET42a	GCCTTCCCACTTCGTTT	23S (1027-1043)	<i>βproteobacteria</i>	35	
GAM42a	GCCTTCCCACATCGTTT	23S (1027-1043)	<i>γproteobacteria</i>	35	
NSO1225	CGCCATTGTATTACGTGTGA	16S (1225-1244)	<i>Ammonia oxidizing β-proteobacteria</i>	35	Juretschko, 1998
NSO190	CGATCCCCTGCTTTTCTCC	16S (190-208)	<i>Ammonia oxidizing β-proteobacteria</i>	55	Mobarry, 1996
NSM156	TATTAGCACATCTTTCGAT	16S (156-174)	<i>Nitrosomonas spp.</i>	5	
NSV 443	CCGTGACCGTTTCGTTCCG	16S (444-462)	<i>Nitrospira spp.</i>	30	
NB1000	TGCGACCGGTCATGG	16S (1000-1012)	<i>Nitrobacter spp</i>	35	
NIT3	CCTGTGCTCCATGCTCCG	16S (1035-1048)	<i>Nitrobacter spp</i>	40	Wagner, 1996
NTSPA662	GGAATCCGCGCTCCTCT	16S (662-679)	<i>Nitrospira genus</i>	35	Daims, 2000

^a rRNA position according to *E. coli* numbering.

^b Percentage of formamide in the hybridization buffer.

Hybridizations were performed at 46°C for 2 h with a hybridization buffer (0.9 M NaCl, 20 mM Tris/HCl, pH 8.0, 0.01% SDS) containing each labeled probe (30 ng/well for Cy3). Target organisms for labeled probes were indicated in Figure 4.8. To ensure the optimal hybridization stringency, formamide was added to the hybridization solution (Table 4.7). After hybridization, unbound oligonucleotides were removed by rinsing with washing buffer containing the same components of the hybridization buffer except the probes.

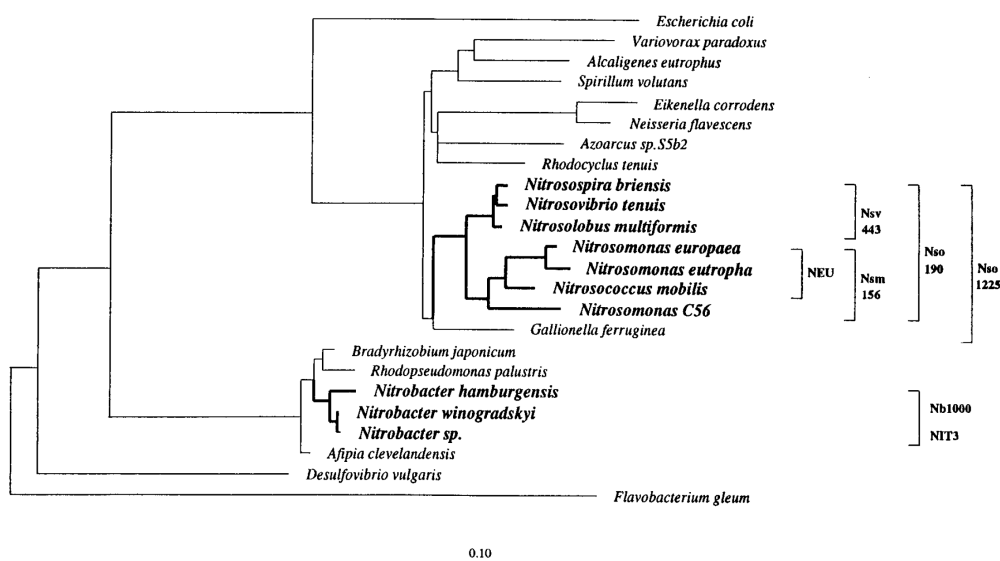


Figure 4.8 Phylogenetic tree inferred from comparison of 16S rRNA sequences. Target organisms for probes Nso190, Nso1225, Nsm156, Nsv443, NEU, NIT3, and Nb1000 are indicated by brackets. The bar represents 0.1 estimated change per nucleotide.

For detection of all DNA, the samples were additionally stained with 4,6-diamidino-2-phenylindole (DAPI) for 10 min in the dark, finally rinsed again with distilled water, and immediately air-dried. The slides were mounted with Vectashield (Vector Laboratories) medium to prevent photo bleaching (Mertoglu et al., 2005). The slides were examined with Leica DM-LB fluorescent microscope and digital images of the slides were captured with Leica DC350F digital camera. For optimal fluorescence detection, the excitation and emission filters should be centered on the dye's absorption and emission peaks. To maximize the signal, one can choose excitation and emission filters with wide bandwidths. Leica DM-LB fluorescent microscope in our study has three dichroic mirror/filter combinations (Table 4.8).

Table 4.8 Fluorescent microscope filter sets

Filter Cube	Excitation Range	Excitation Filter	Dichromatic Mirror	Suppression Filter
A4	UV	BP 360/40	400	BP 470/40
L5	blue	BP 480/40	505	BP 527/30
Y3	green	BP 545/30	565	BP 610/75

4.4.7. Slot-Blot Hybridization

Slot blot hybridization was performed with DIG-labeled oligonucleotide to investigate the variations and activity of nitrite oxidizing bacteria (NOB). DIG-labeled oligonucleotide probes targeting *Nitrospira* (GGA ATT CCG CGC TCC TCT) and *Nitrobacter* (CCT GTG CTC CAT GCT CCG) were used to investigate the nitrite oxidizing population. All microorganisms were detected by using Universal specific oligonucleotide probe UNIV1390 (GAC GGG CGG TGT GTA CAA). PCR-amplified 16S rRNA bacterial genes were used to quantify relative differences of NOB during the operational period of BAC columns with relative hybridization signal intensity.

For experimental procedures, the manufacturer's protocol was followed. DNA products were heated at 95 °C for 10 min and chilled on an ice bath. Then, 5 µl of each amplification mixture was spotted on a nylon membrane using a Minifold II slot blotter (Schleicher and Schuell, Fredriksberg, Denmark) and UV-fixed (Vilber Lourmat, France). After UV-crosslinking, the membrane was cut into slices and dried to ambient air. For hybridization, the membrane slices were each pre-incubated in a 50-mL falcon tube in a hybridization oven at optimum hybridization temperature for 30 min with 10 mL of pre-hybridization buffer (Boehringer Mannheim GmbH, Biochemica).

Hybridization and detection of oligonucleotide probes were achieved by DIG (digoxigenin) System (Boehringer Mannheim GmbH, Biochemica) according to the manufacturer's protocol. DIG-labeled oligonucleotide probes were hybridized for more than six hours with DIG Easy Hybridization buffer (Boehringer Mannheim GmbH). After washing, anti-DIG alkaline phosphatase conjugate was applied so that antibody hapten

complex could be formed. Subsequent enzyme-catalyzed color reaction with BCIP (5-bromo-4-chloro-3-indolyl phosphate) and NBT (nitroblue tetrazolium salt) produced blue precipitates on the membrane.

4.4.8. Real-time PCR analysis

Ammonia oxidizing bacteria (AOB) were analyzed by real-time PCR using primers that targeted the *amoA* gene with a LightCycler device (Roche, Mannheim, Germany). The standard SYBR Green detection was carried out using the LightCycler FastStart DNA Master SYBR Green I kit (Roche, Mannheim, Germany) following the manufacturer's protocol. SYBR Green is a fluorescent dye that binds unspecifically to double-stranded DNA. Fluorescent emission is directly proportional to the amount of amplification product and was automatically measured at the end of the annealing period of each cycle at 84°C and 530 nm to monitor the progress of amplification. Reactions were performed in a volume of 20 µL. The reaction mixture contained 2 µL, 1x Mastermix (Roche); 2 µL, 25 mM MgCl₂; 1.25 µM concentrations of each primer, PCR grade distilled water and 2µL diluted template DNA. Real-time PCR was started with an initial denaturation at 95°C for 10 min. Subsequently, the cycling program was followed by 40 cycles of 5 s of denaturation at 95°C, 20 s of annealing at 57°C, and 45 s of elongation at 72°C. The temperature transition rates were programmed at 20°C/s. Fluorescence was detected after each cycle at 84°C to avoid detection of primer dimers (Petersen et al., 2004). In all applications, negative controls without template DNA were subjected to the same procedure to detect any possible contamination.

The specificity of amplified PCR products were assessed by performing a melting curve analysis, gradual denaturation with a temperature transition rate of 0.1°C /s from 65°C to 95°C with a continuous monitoring of fluorescence. The melting temperature (T_m) of PCR products is the temperature at which 50% of the strands of the target gene have dissociated, and was derived from the inflection point of the fluorescence (F) versus temperature (T) curves, or the peak value of the $-dF/dT$ versus T curves (Ririe et al., 1997). An external standard curve showing the relationship between *amoA* and 16S rDNA copy numbers and C(t) values was constructed using serial dilutions of a known copy number of target genes. The R² values were greater than 0.98 for all of the standard curves. Standard

copy number of *amoA* gene was prepared from PCR products of previously cloned *Nitrosomonas eutropha*. The concentration of amplified DNA was determined by measuring absorbance at 260 nm with the Shimadzu UV2450 spectrophotometer (Shimadzu Co., Kyoto, Japan).

4.5. Morphological Studies by Environmental Scanning Electron Microscopy (ESEM)

ESEM images were obtained by a Philips XL30-FEG Environmental SEM operating at the wet mode. Environmental SEM analyses eliminated the requirement of sample preparation, which is necessary in conventional SEM. In ESEM analysis, samples were placed in the microscope after filtering through 0.45 µm Millipore filters and the temperature was applied as 25°C and pressure was 0.3-0.6 Torr. This method gave much better views of microorganisms. Magnification was up to 15000 times.

5. RESULTS AND DISCUSSION

5.1. Characterization of Raw Water Samples

5.1.1. Water Quality Parameters

Raw water samples were brought from the Ömerli reservoir, which supplies water to some regions in Istanbul at a rate of 1,000,000 m³/d. It is the biggest reservoir of Istanbul in terms of water supply potential. The reservoir provides approximately 48 % of the city's drinking water. It is located in northeast (approximately 30 km) of the city. Morphologically, the reservoir has a surface area of 23.5 km² and a volume of 2.2x10⁶ m³ (www.dsi.gov.tr). There are four main streams which are feeding the reservoir at present, which are; Ozan, Gökçebeyli, Ballica and Kömürlük. The fifth stream named Paşaköy which was feeding the reservoir until 2004 has been connected to the Riva Stream via a tunnel (3 m diameter and 6 km length) by ISKI in order to prevent domestic and industrial wastewater inputs into the reservoir. Due to the input of very small amounts of domestic wastewater and due to the present organic carbon content of the source, the whole water body is mesotrophic. Ömerli reservoir supplies water to five treatment plants, namely, Orhaniye, Osmaniye, Muradiye, Ertuğrul Gazi and Emirli.

The reservoir has a big water intake structure in the middle of the lake with sluice gates at different elevations. Taking the water at different water elevations provides the flexibility to withdraw water from the depth that has a better quality. Therefore, depending on the season, water samples withdrawn from the most convenient elevation were regularly supplied to the laboratory. As soon as the water sample arrived to the laboratory, some water quality parameters were measured. Table 5.1 shows the average values of these measurements along with minimum, maximum values and standard deviations and represents the average values of approximately 60 measurements.

Table 5.1 Raw water characterization

	Average (S.D.) ¹	Minimum Value	Maximum Value
TOC, mg/L	4.06 (0.63)	2.95	5.12
DOC, mg/L	3.65 (0.53)	2.85	4.89
NH ₄ -N, mg/L	0.34 (0.29)	0.15	0.98
NO ₃ -N, mg/L	0.66 (0.39)	0.16	1.45
NO ₂ -N, mg/L	0.03 (0.02)	0.004	0.05
pH	7.85 (0.49)	7.53	8.27
Alkalinity, mg/L as CaCO ₃	58.28 (5.70)	47.5	68.77
Hardness, mg/L as CaCO ₃	78 (6.30)	54	90
Conductivity, μ S/cm	255 (35)	200	395
Fe ²⁺ , mg/L	0.02 (0.01)	0.01	0.125
Mn ²⁺ , mg/L	0.07 (0.04)	0.03	0.354
UV ₂₅₄ , cm ⁻¹	0.093 (0.02)	0.067	0.211
UV ₂₈₀ , cm ⁻¹	0.073 (0.02)	0.052	0.175
SUVA, L/mg ⁻¹ .m ⁻¹	2.54 (0.559)	1.99	5.26

¹ S.D., standard deviation

Values shown on Table 5.1 are the average of year round measurements. TOC and DOC values are higher at summer months (data not shown) due probably to the lack of enough rain to the catchment area. This causes the organic carbon to concentrate at the source.

5.1.2. Ozone Demand of Raw Water

Ozone demand is the amount of ozone consumed by oxidizable material in the water like Fe²⁺, Mn²⁺, H₂S, and organic matter. Some factors that affect the ozone demand are temperature, pH, alkalinity, and organic content etc (Langlais et al., 1991). The ozone demand for water must be determined empirically by continuously monitoring the ozone concentration in water during ozone application.

Ozone concentration data obtained at an ozone application rate of $9.84 \text{ mgO}_3 / \text{min}$ was used to find the time required to satisfy the ozone demand. The ozone demand experiment was conducted in a 7 L vessel. DOC of the raw water at the time of the experiment was 3.03 mg/L . The experiment was performed at 20°C of water temperature. Figure 5.1 shows the ozone demand and accumulation and decay of ozone in raw water.

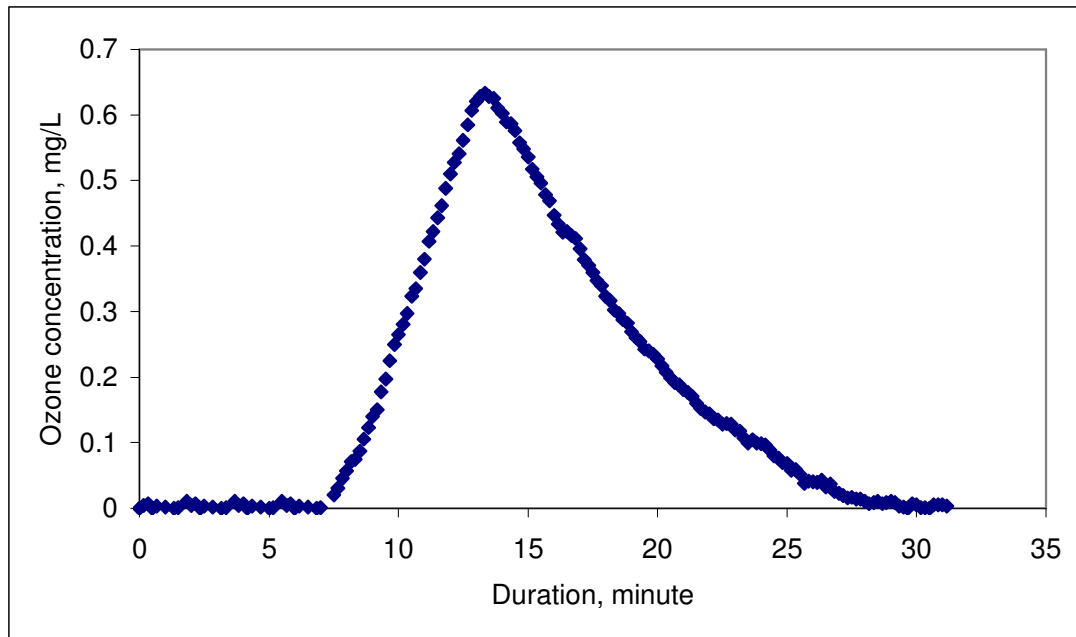


Figure 5.1 Change in ozone concentration with applied ozone

As can be seen in Figure 5.1, when ozone is applied to the water, there is no change in the ozone concentration for the first 7.33 minutes. This shows the ozone demand of water. The amount of ozone needed for oxidation is expressed in terms of ozone dosage. Therefore, the time should be converted into ozone concentration. The following formula was used for this purpose:

$$\text{Ozone Demand} = \frac{\text{Ozone application rate}(\text{mgO}_3 / \text{min}) \times \text{Time}(\text{min})}{\text{Ozonated water volume}(\text{L})} \quad (5.1)$$

The time term in Equation 5.1 indicates the time required for ozone to remove all oxidizable material. Solving Equation 5.1 gives an ozone demand of 10.3 mg/L for the raw water. Mousset et al. (1997) and Cho et al. (2003) reported that most of the ozone demand is due to the reaction of ozone with natural organic matter. NOM consumes the dissolved ozone by direct reaction with molecular ozone. Other ozone demanding substances such as iron, manganese, hydrogen sulfide contribute to ozone consumption in direct relation with their concentration.

Dissolved ozone residual appears after the applied dose surpasses the ozone demand. Then, there is a sharp increase in ozone concentration, which shows the ozone accumulation phase. When ozone application is stopped ozone decomposition takes place.

5.1.3. UV–Visible Absorbance Spectrum of Raw Water

In general, the NOM in water would absorb light in UV (200-400 nm) and visible (400-700 nm) regions and uncharacteristic spectra would be produced. There is no apparent difference between the spectra for humic and fulvic acids. It has been shown that no maximum or minimum peaks are present on the UV-Visible spectra of aqueous solutions of humic acids (Choudhry, 1984) and the optical absorbance decreases as the wavelength increases.

Although the NOM with different origins may have different elemental compositions and other chemical properties, their spectra are similar. In general, light absorbance of humic substances in the water will increase with the degree of aromatic rings in the humic substances, the ratio of carbon in aromatic nuclei to carbon in aliphatic or alicyclic side chains, the total carbon contents in the water, and the molecular weights of humic acids. The direct measurement of the UV spectrum provides convenient and useful information for characterization of NOM.

The broad diversity of the chromophores in NOM molecules causes the different absorbance bands to overlap and merge so that the overall UV absorbance spectrum of natural water resembles a single, smooth hump as shown in Figure 5.2.

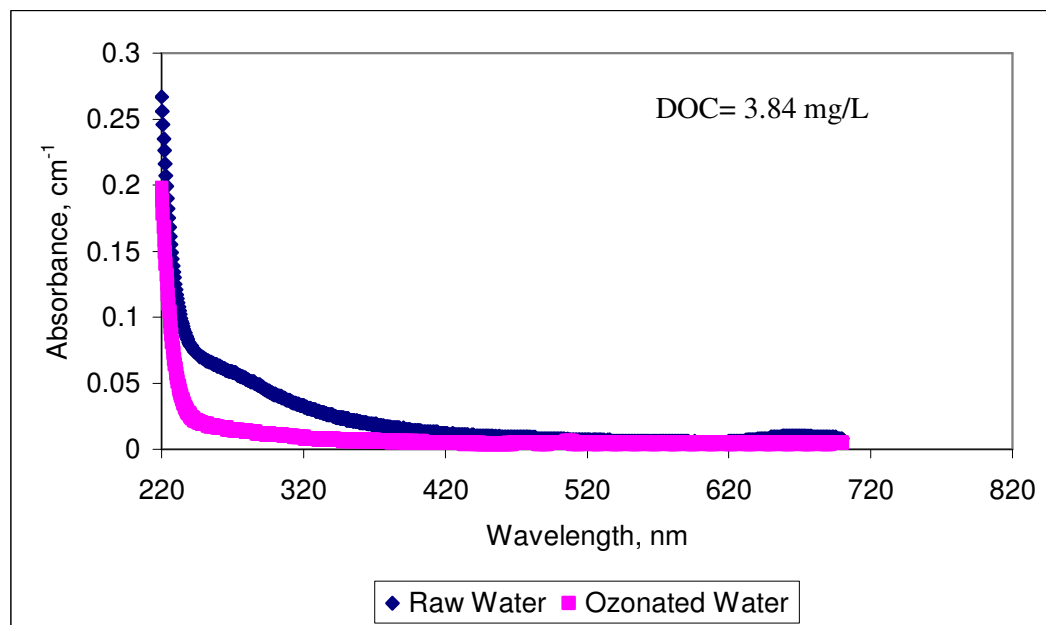


Figure 5.2 UV-Visible absorbance spectrum of the raw and ozonated (2 mgO₃/mgDOC) water

Key features of the spectra include a shoulder in the range of 210 – 230 nm and a gradual decrease in the absorbance at wavelengths greater than 230 nm for both samples. Ozonation dose was adjusted so that it did not result in DOC mineralization, but only in breaking of the aromatic structure (2 mgO₃/mgDOC). Therefore, the DOC concentration after ozonation was the same as that of raw water. However, ozonation does induce major changes in the chemistry of NOM. Since ozone oxidizes aromatic rings and since the UV absorbance is sensitive to the concentration of those functional groups, the decrease in absorbance caused by ozonation is significant.

5.1.4. Optimum Ozone Dosage for Maximum Biodegradability

In combined ozone and biologically activated carbon (BAC) applications, BDOC is removed by biodegradation on GAC surface. Usually, the major objective of ozonation in these situations is to maximize the production of BDOC, which can be removed by subsequent biodegradation. However, excessive ozone application can also lead to the complete mineralization of DOC which should be avoided because mineralization by oxidation with ozone is much more costly than by biodegradation in practice. Therefore, in

order to find the optimum ozone application rate, different ozone dosages were applied to the raw water in the range of 0.5 - 3 mg O₃/ mg DOC. Increasing the ozone dosage beyond 2 mg O₃/mg DOC resulted in a distinct decrease in the initial DOC of samples. The aim here is not to oxidize the organic matter by ozonation, but rather to find the optimum ozone dosage to achieve the maximum biodegradability. Therefore, higher ozone dosages resulting in more than 5% decrease in the initial DOC were not tested. The optimum ozone dosage experiment was repeated twice under fixed experimental conditions. In each experiment the average of triplicate DOC measurements was taken.

After ozonation, water samples were filtered through 0.45 µm pore size glass fiber filters and raw water, which is filtered through 2 µm pore size filter, was added as an inoculum. The solution was then incubated at exactly 20°C in the dark for 28 days. DOC concentration was measured regularly to check the rate of decrease in the DOC content during the course of incubation. Figure 5.3 shows the decrease in DOC during the 28 days of incubation period.

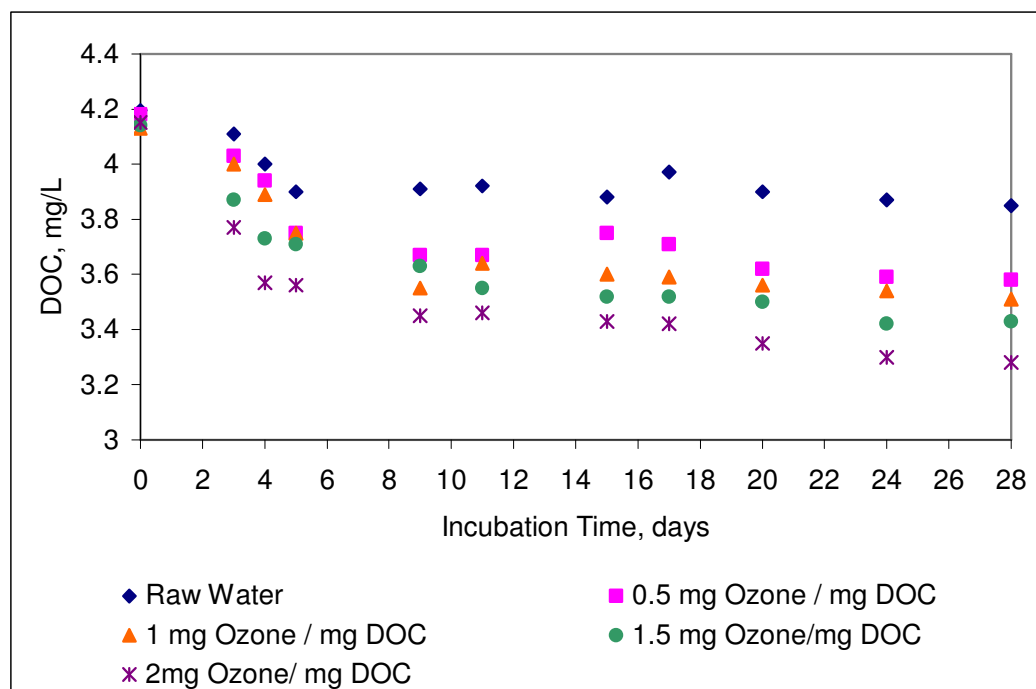


Figure 5.3 DOC profiles of the ozonated water samples during BDOC test

As shown in Figure 5.3, increasing the ozone dosage resulted in a continuous decrease in DOC during the incubation period of 28 days. However, a rapid decrease in TOC during the 5 days was replaced by a relatively inconsiderable decrease for the remaining days of incubation. From these results, it can be deduced that rapidly forming BDOC ($BDOC_{\text{rapid}}$) can be obtained within 5 days while the remaining decrease in TOC content only contribute to slowly forming BDOC ($BDOC_{\text{slow}}$).

The BDOC amount was simply found by subtracting the final DOC at the end of 28 days of incubation period from the initial DOC using the data presented in Figure 5.3. These results can be used to obtain the relationship between the applied ozone dosage per DOC and the BDOC formation. BDOC formation with respect to ozone dosage is illustrated as shown in Figure 5.4. Error bars at each data point indicate 95% confidence intervals for duplicate tests.

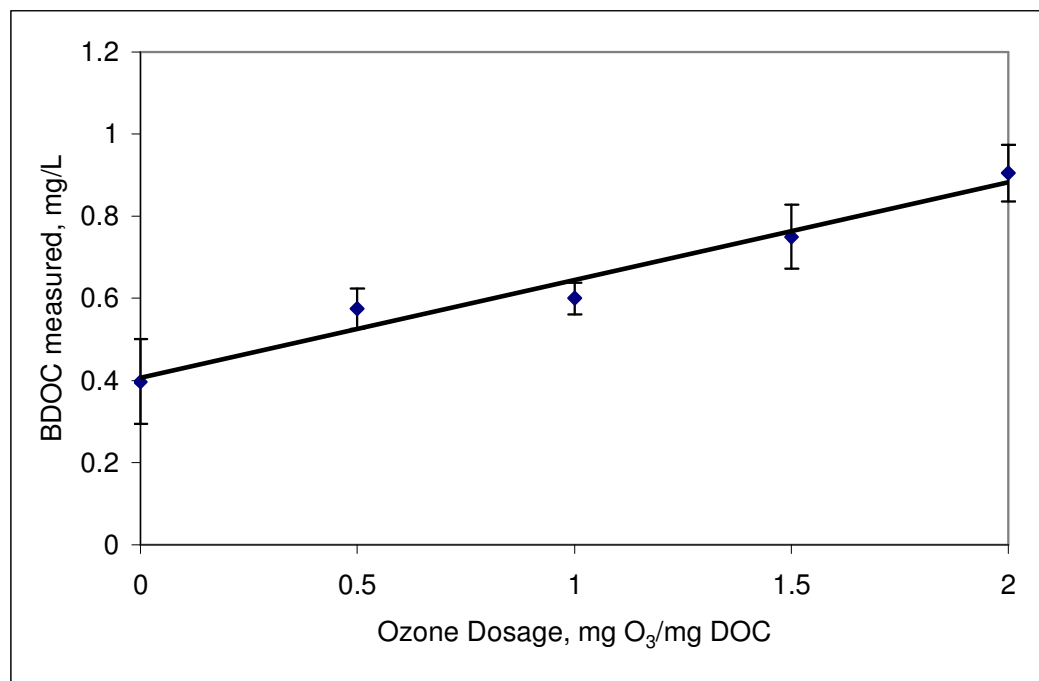


Figure 5.4 BOD observed with respect to ozone dosage

As expected, ozonation increased the biodegradability of organic matter. For ozone doses ranging from 0.5 to 2 mg O₃/mg DOC, BDOC increased linearly. As mentioned, ozone doses higher than 2 mg O₃/mg DOC resulted in organic carbon mineralization. Therefore, this dosage is the optimum for Ömerli raw water to produce the maximum amount of BDOC and higher ozone dosages should not be employed in biofiltration experiments.

In literature, different optimum ozone dosages were reported which result in maximum BDOC formation. Several researchers have reported optimum ozone doses as low as 0.25-0.5 mg O₃/mg DOC (Volk et al., 1993; Roche et al., 1994; Yavich et al., 2004). The organic matter in the Ömerli water samples seems to be more refractory to ozonation than in other studies. However, it should be considered that other researchers report high optimum doses of about 2-2.5 mg O₃/mg C (Malley et al., 1993; Owen et al., 1995; Shukairy et al., 1994). This can be attributed to the differences in type and amount of organic matter in water resources. Various organic and inorganic constituents can compete for ozone, accelerate or hinder the self decomposition of ozone, scavenge free-radicals, and affect mass transfer characteristics (Gürol, 1985). Therefore, the experience with one water cannot be extrapolated to another one without characterization of the water.

5.1.5. Change in Absorption Spectrum upon Ozonation

The change in UV absorbance and SUVA values with ozonation has been examined for the Ömerli water. The results are summarized in Table 5.2.

Table 5.2 Characterization of organic content based on absorption measurements

mgO ₃ /mgDOC	Initial DOC, mg/L	UV ₂₅₄ , cm ⁻¹	UV ₂₈₀ , cm ⁻¹	SUVA, m ⁻¹ /(mg DOC/L)
0	4.295	0.057	0.034	1.33
0.5	4.18	0.055	0.032	1.32
1	4.13	0.045	0.024	1.09
1.5	4.14	0.038	0.022	0.92
2	4.15	0.036	0.022	0.87
2.5	3.85	0.030	0.019	0.78

Table 5.2 shows that, up to an ozone dose of 2 mg O₃/mg DOC, the percent decrease in the initial DOC is as low as 3.4 % whereas for UV₂₅₄, UV₂₈₀ and SUVA, they are 36.8 %, 35.3 % and 34.6 % respectively. Thus, even if there is no significant decrease in DOC upon ozonation, in terms of UV absorbing species a significant removal is observed. This is due to the fact that UV absorbances are more specific parameters than DOC. Ozonation up to the dosage of 2 mg O₃/mg DOC, breaks only the aromatic structure of the NOM molecule, but does not result in mineralization. Since the UV absorbance is sensitive to the concentration of those functional groups (aromatic rings), breaking the structure of aromatic rings results only in the decrease in UV absorbance. The unsaturated carbon bonds including aromatic compounds which absorb UV in the range of 254-280 nm are generally recalcitrant for biodegradation. Considering the results presented in both Figure 5.4 and Table 5.2, it was seen that the decrease in the UV absorption resulted in the increase of biodegradability of water samples. The correlation between the increase in biodegradability and decrease in UV absorbance is demonstrated in Figure 5.5.

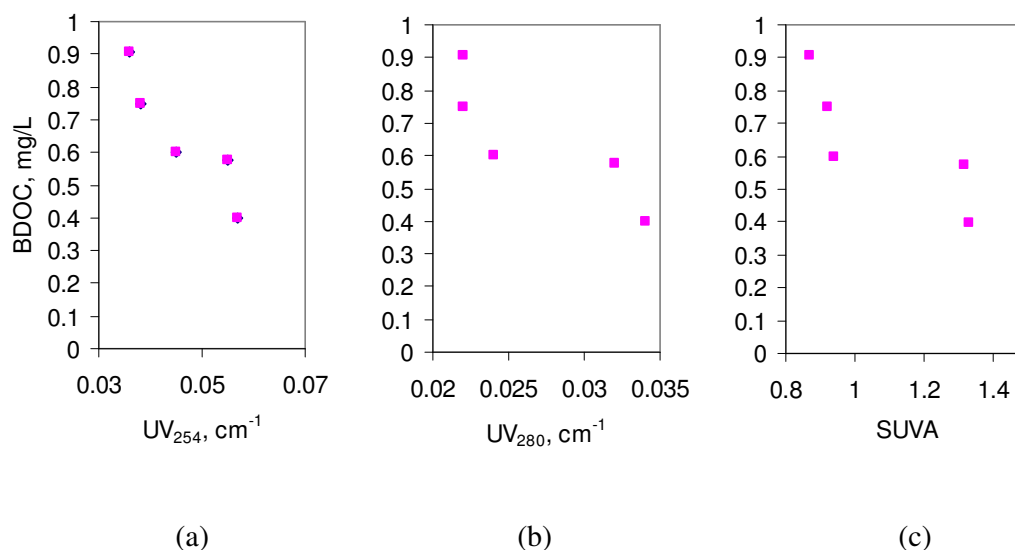


Figure 5.5 Relationship between the (a)UV₂₅₄ (b) UV₂₈₀ absorbance (c) SUVA and biodegradability as shown by BDOC

Both UV absorbances and SUVA values in the water decrease with ozonation, and this reduction is coupled with the increase in BDOC concentration, which is the indicator of biodegradability. The Pearson's product momentum correlation coefficient (r_p) for the relationship was used for linear estimation of the strength and direction of the correlation.

Each of the negative correlation was strong (-0.85 for UV₂₈₀ and BDOC, -0.82 for SUVA and BDOC). On the other hand, the strongest correlation was obtained by the correlation between the UV₂₅₄ and BDOC with a Pearson's coefficient of -0.92.

5.2. Batch Adsorption – Desorption Experiments

Batch adsorption – desorption experiments and all charge determinations were conducted with four granular activated carbon grades (explained in detail in Section 4.1.3.3.) and with the following water samples (explained in detail in Section 4.1.3.7.):

1. Raw water samples
2. Ozonated water samples
3. Biologically treated water
4. Ozonated – biologically treated water

In order to evaluate the effect of electrostatic charge on adsorption-desorption, the charge on NOM and GAC were determined. Numerous studies have shown that the surface chemistry of activated carbons can substantially influence adsorption of organics (including NOM). A better understanding of surface chemistry can help in choosing the appropriate carbon for a particular adsorption.

5.2.1. Charge on NOM

The charge of NOM for all types of water samples was determined in the pH range of 3 to 9. Newcombe et al. (1996) found that electrostatic NOM effects at pH values around 3 are negligible and that NOM is fully protonated. This was taken as the starting point of titration for the NOM solution and assumed that the charge of NOM at pH is zero.

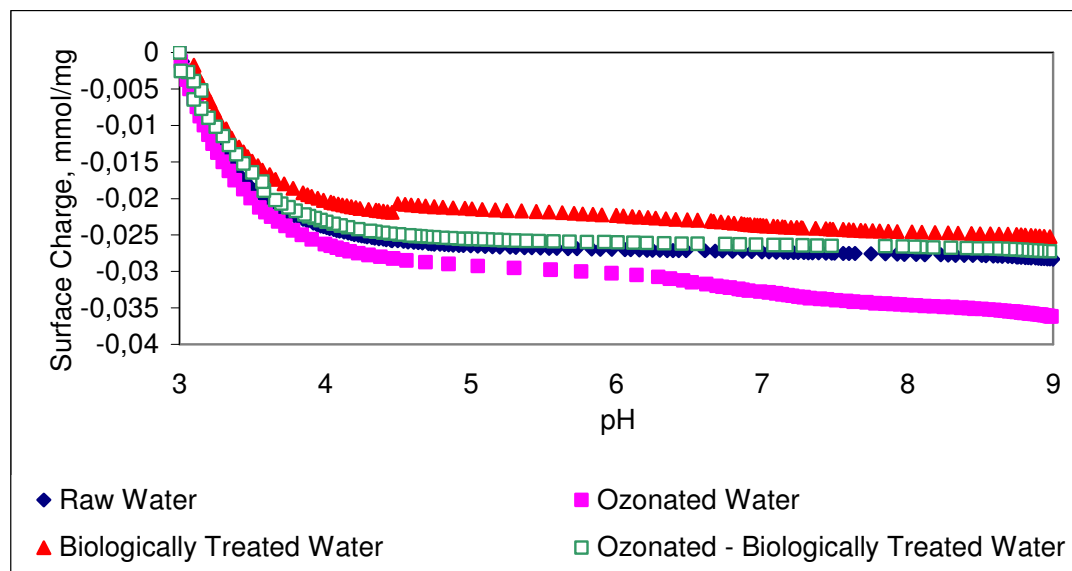


Figure 5.6 Surface charge of NOM in different water samples between pH 3-9

Figure 5.6 suggests that the charge on NOM is very much dependent on pH and increases with pH. The curves reached a plateau at higher pH values, which denote the full ionization of the carboxyl groups on NOM as reported by Newcombe et al (1997). As expected, ozonation increased the charge on NOM 30% compared to raw water (-0.027 mmol/mg DOC to -0.034 mmol/mg DOC) at pH 7.6. The increase can be explained by the formation of more polar compounds which are hydrophilic (Amy et al., 1988) as a result of cleavage of larger molecules during ozonation. Moreover, the charge of NOM is less in biologically treated water samples compared to raw water. The charge difference was found to be significant at a 95% confidence interval ($p < 0.05$) from a statistical point of view. This means that, BDOC has a more negative charge than the nonbiodegradable portion in DOC. During biological removal of NOM, some biodegradable groups in NOM like amino acids, fatty and aromatic acids, carbohydrates, certain humic substances are biodegraded. Similarly, in biological treatment of ozonated water samples, the same compounds plus organic ozonation by-products, e.g. aldehydes, carboxylic acids and aldo/keto acids (Agbekodo et al., 1996) are removed by biodegradation. Elimination of BDOC from solution may play a role in decreasing the negative charge.

5.2.2. Point of Zero Charge (pH_{PZC}) of Several GAC Grades

The point of zero charge (pH_{PZC}) is the pH at which the GAC surface carries a net charge of zero. For a solution pH greater than the pH_{PZC} , the activated carbon carries a net negative surface charge, while for pH values below this value the carbon has a net positive charge. The net surface charge of the GACs was determined by titration and is shown in Figure 5.7.

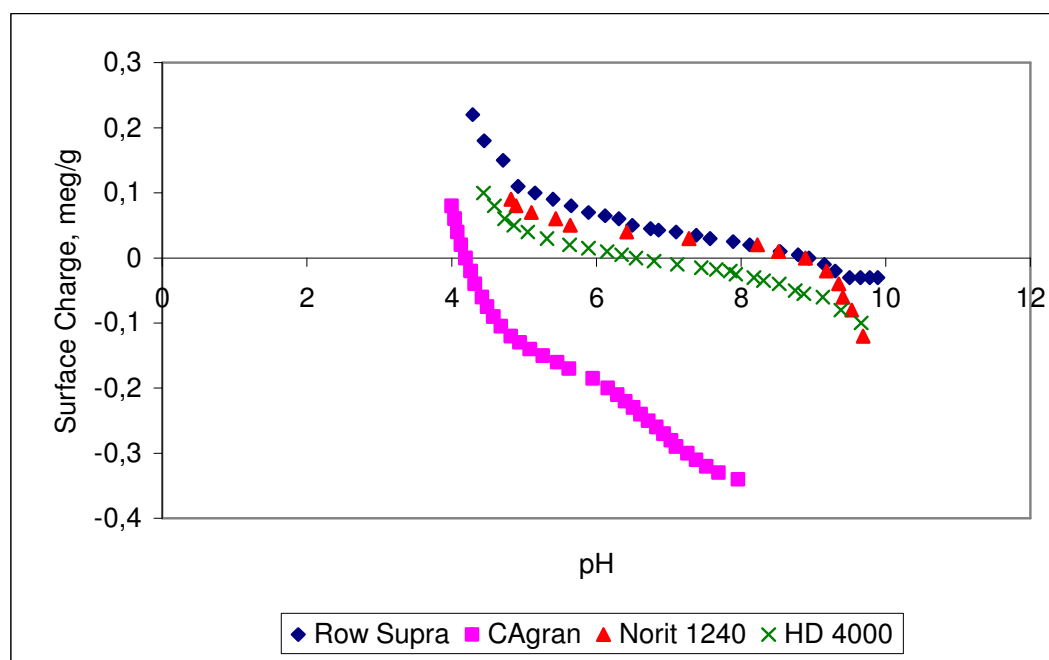


Figure 5.7 Surface charge of the activated carbon samples

The net surface charge of Norit 1240 and Row Supra is mainly positive. Norit 1240 and Row Supra have pH_{PZC} of 8.9 and 8.95, respectively. However, CAgran is negatively charged at pH values higher than 4.2. For HD4000, the surface charge varies from positive at pH 6.5 to negative at higher pH values. It is worth noting that the average pH value during the adsorption tests was 7.6. This means that at the current situation, Norit 1240 and Row Supra is positively charged, CAgran and HD4000, on the other hand, is negatively charged. As far as electrostatics forces are concerned, a positively charged activated carbon should be proficient in adsorbing the negatively charged adsorbate, e.g. NOM.

5.2.3. Boehm Titrations

The total acid neutralization capacity and acidic surface functional groups on the GAC surface were characterized with an alkalimetric titration technique (Boehm, 1966) and the results were presented in Table 5.3.

Table 5.3 Surface functional groups on GACs used in this study

GAC type	NaHCO ₃ titration	Na ₂ CO ₃ Titration	NaOH titration
	Carboxylic groups (strong)	Carboxylic groups (weak)	Phenolic Groups
	(meq/g)		
Norit 1240	0.09	0.28	0.23
Row Supra	0.21	0.28	0.20
HD4000	0.08	0.44	0.48
CAgran	0.28	0.59	0.50

5.2.4. Equilibration Time for Adsorption and Desorption

Batch adsorption isotherms tests were done prior to column tests to have an idea about column behavior. However, the results of batch and column tests may depict different characteristics of the carbon. Results obtained from batch tests represent the maximum uptake for a given carbon at a given NOM concentration. In contrast, column tests depict the adsorption of NOM from the solution passing through the carbon, where time is an issue. Nonetheless, batch tests were done due to their simplicity and quickness to compare the results of different GAC alternatives.

Prior to starting the batch isotherms, the equilibration time for each carbon was determined. Water samples were shaken until equilibrium was reached between the solid and the liquid phases. The equilibrium time was determined at a chosen GAC concentration (75 mg/L). DOC concentration was determined with respect to time and the results were presented in Figure 5.8.

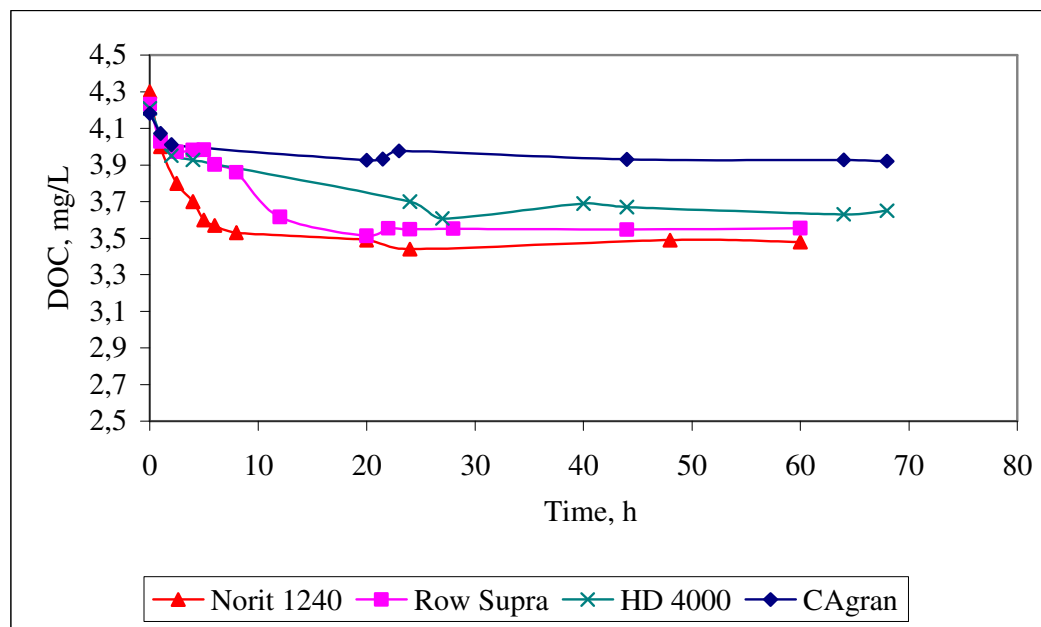


Figure 5.8 Adsorption equilibrium time for raw water samples

The time required to reach equilibrium TOC concentration is defined as the equilibrium time for adsorption. In literature, commonly 1-30 days of equilibration time for the NOM adsorption was used. For example, Storrar (2006) chose 30 days to ensure adsorption experiments to come to a full equilibrium condition. Of course, there are other studies having equilibration time more than 15 days and up to 30 days. However, in the studies of Newcombe and Drikas (1997) and Bjelopavlic et al. (1999), 3 days of equilibration time was found to be sufficient. Similarly, Moore (2000) used 24 hours of equilibration time. In the present study, as seen in Figure 5.8, all GAC types were observed to reach equilibrium in 24 hours.

Similarly, the equilibrium time for desorption was determined using a known concentration of loaded GAC (8 mg/L). DOC concentration in the bulk liquid was determined at regular intervals and the results were presented in Figure 5.9.

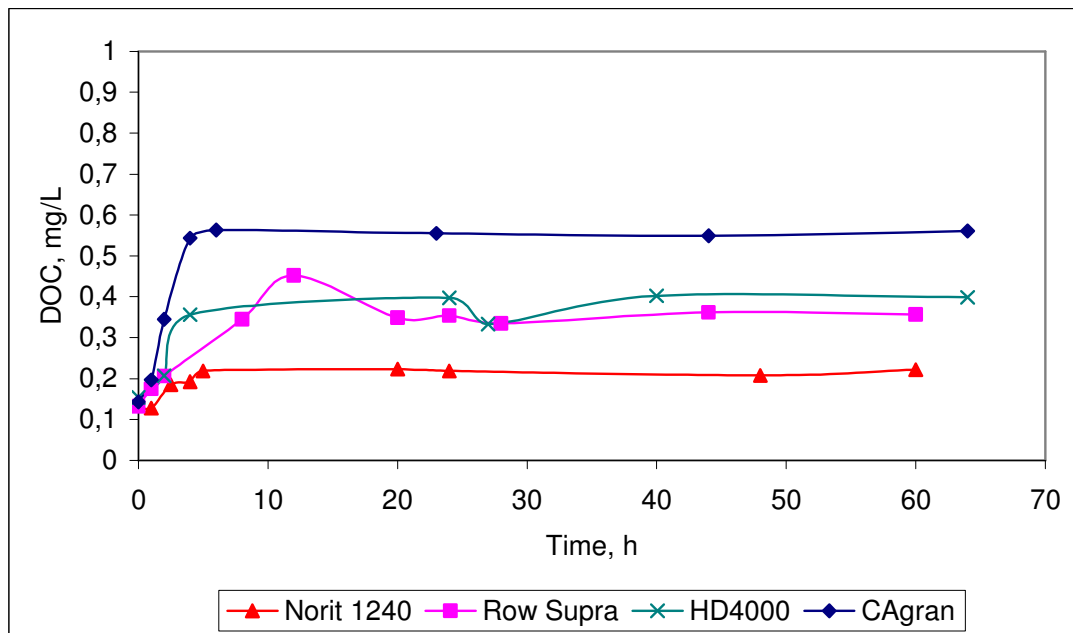


Figure 5.9 Desorption equilibrium time for raw water samples

Figure 5.9 suggests that desorption equilibrium was reached very fast. An equilibrium time of 24 hours is enough for the desorption of DOC from the loaded carbon samples.

5.2.5. Adsorption Isotherms

Equilibrium concentrations have been utilized to construct adsorption isotherms. Both Langmuir and Freundlich adsorption models were applied to experimental data. However, satisfactory correlations could not be attained with the Langmuir model. The Langmuir fits of the experimental data were presented in Appendix B.

The adsorption isotherms obtained for the water samples based on UV_{254} parameter are presented in Appendix C.

If the adsorption isotherms are determined for heterogeneous mixtures of compounds as is the case in Ömerli Reservoir, the shape of the isotherm can vary widely in their affinity for the adsorbent. The shape of the isotherm will depend on the relative

amounts of the compounds in the mixture, especially if compounds are determined using group parameters such as TOC, DOC or UV absorbance. Figure 5.10, Figure 5.11, Figure 5.12 and Figure 5.13 show the adsorption of NOM onto the four types of activated carbon. The average initial DOC concentration for the raw water, ozonated water, biologically treated water and ozonated -biologically treated water were 4.23, 4.12, 3.88 and 3.43 mg/L, respectively.

The isotherms indicate different fractions in raw water having different adsorption parameters. The adsorption regions were as follows:

1. Region I. Nonadsorbable fraction left over at high GAC doses
2. Region II. Adsorption at medium doses
3. Region III. Adsorption at low GAC doses

These regions were also marked in Figures 5.10 through 5.13.

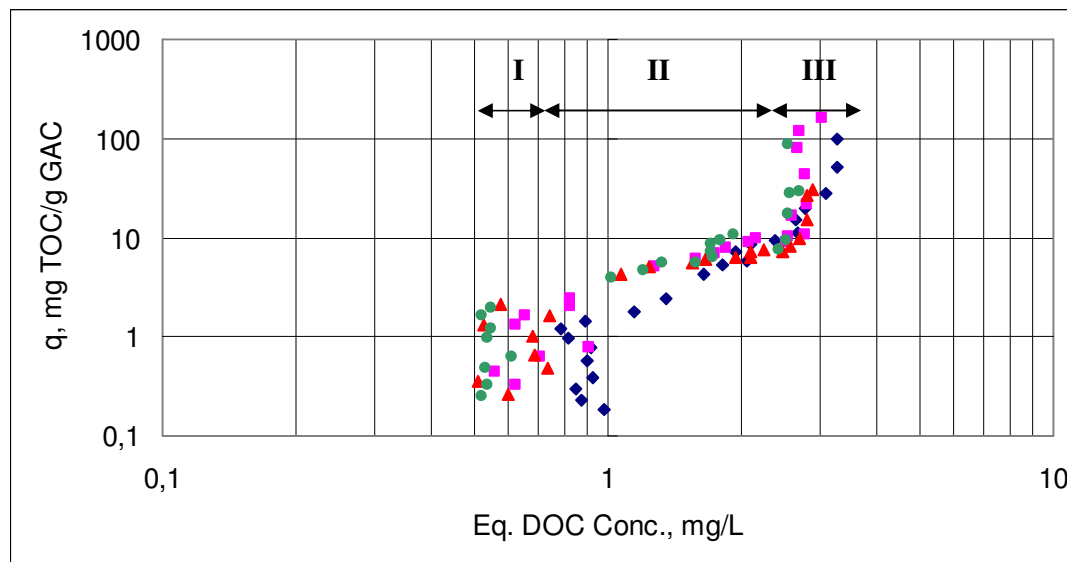


Figure 5.10 Freundlich isotherms of Norit 1240 (I: Nonadsorbable fraction left over at high GAC doses, II: Adsorption at medium doses, III: Adsorption at low GAC doses)

◆ Raw Water ■ Ozonated Water ▲ Biologically Treated Water ● Ozonated - Biologically Treated Water

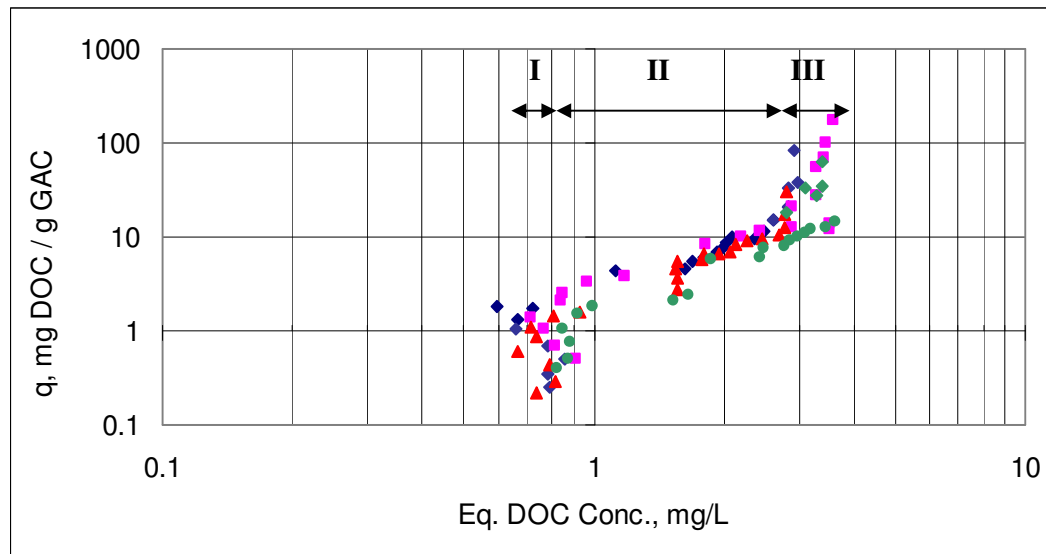


Figure 5.11 Freundlich isotherms of Row Supra (I: Nonadsorbable fraction left over at high GAC doses, II: Adsorption at medium doses, III: Adsorption at low GAC doses)

◆ Raw Water ■ Ozonated Water ▲ Biologically Treated Water ● Ozonated - Biologically Treated Water

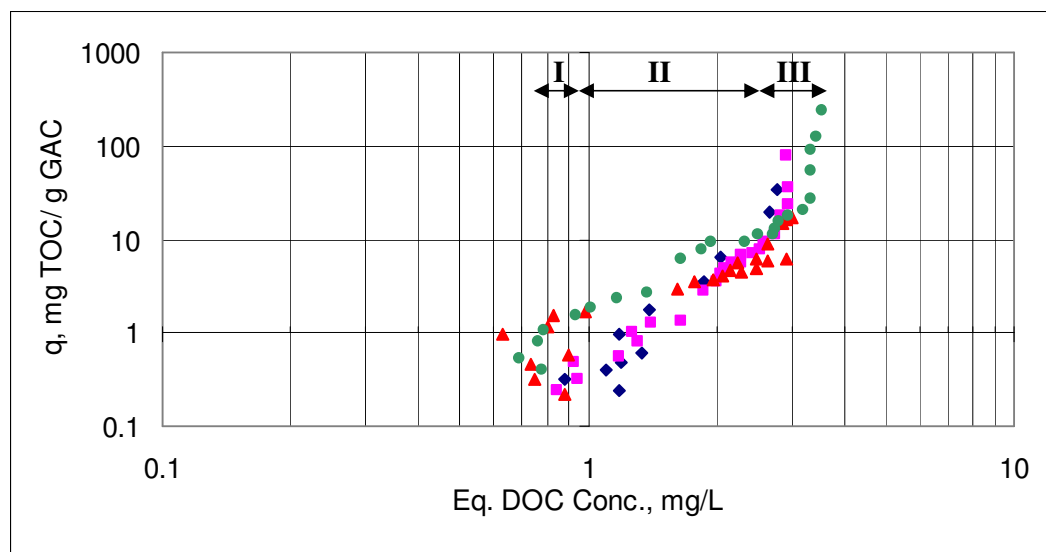


Figure 5.12 Freundlich isotherms of HD 4000 (I: Nonadsorbable fraction left over at high GAC doses, II: Adsorption at medium doses, III: Adsorption at low GAC doses)

◆ Raw Water ■ Ozonated Water ▲ Biologically Treated Water ● Ozonated - Biologically Treated Water

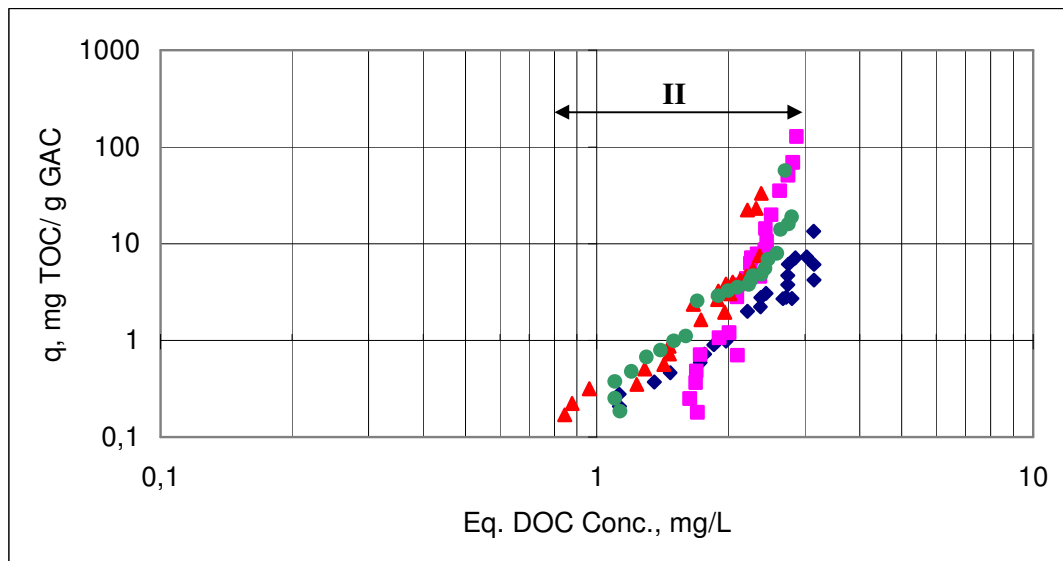


Figure 5.13 Freundlich isotherms of Cagran (II: Adsorption at medium doses)

◆ Raw Water ■ Ozonated Water ▲ Biologically Treated Water ● Ozonated - Biologically Treated Water

5.2.5.1. Region I: Nonadsorbable fraction left over at high GAC doses. The steep slope obtained at high GAC doses and at low equilibrium concentrations (Region I) indicate the nonadsorbable portion. The nonadsorbable fraction of NOM is defined as the minimum value of c_e that could be attained by increasing GAC dosage up to a theoretically infinite value. The weakly adsorbable/ nonadsorbable portion of DOC for the water samples ranged between 0.7-0.9 mg/L on average for Row Supra, Norit 1240, and HD 4000. The statistical significance at a 95 % confidence interval ($p < 0.05$) was investigated for the weakly adsorbable/ nonadsorbable DOC concentrations for each carbon type using ANOVA. The results indicated that this fraction did not significantly differ among different water types. In the case of adsorption onto CAggran, a significant nonadsorbable region was not observed except the ozonated case. Unlike other carbon types, in the case of CAggran, ozonation increased the amount of the nonadsorbable fraction. Adsorption may be hindered if most of the pores in GAC are considerably larger than the NOM even if the carbon's surface area is high. CAggran has a very open (both meso and macro) pore structure as seen from Table 3.1. It is reported in literature that ozonation is responsible for the shift of molecular size distribution to lower values (Meijers, 1977; Langlais et al., 1991;

Volk et al., 1993). Production of the lower molecular weight organics may be the major cause of this observation.

5.2.5.2. Region III: Adsorption at Low GAC Doses. Region III corresponds to low GAC doses, where there is little or no change in the equilibrium DOC concentration. Increasing the GAC dose in this region resulted in the decrease in q (mg DOC/g GAC). A small decrease in equilibrium DOC concentration as a result of a small GAC addition leads to a large decrease in q as shown by the steep slope (high $1/n$) in the adsorption isotherm. This means that even if the GAC concentration is increased, the equilibrium DOC concentration is not so much affected. This situation indicates an inferior adsorption at low GAC doses. Actually, the organic molecules adsorbed at these low doses can be regarded as the easily adsorbable ones which have a high affinity to the carbon and are preferentially removed from the solution. Large humic molecules having different functional groups may surround the activated carbon surface like a blanket. This may prevent the adsorption of the smaller molecules and may result in inefficient utilization of GAC's porous structure. But the fraction of these large molecules in DOC is usually low. The organic molecules that are adsorbed at these low doses should have high affinities to the carbon. When low GAC doses are added, only they are removed and the equilibrium DOC reflects the less adsorbable organics remaining in solution as shown by Sontheimer et al (1985). This would be the reason why they are preferentially removed from the solution compared to other organics remaining in solution.

The Freundlich coefficients were not calculated for Regions I and III. As explained earlier, nearly vertical lines are obtained in these regions showing that adsorption is unfavorable so that calculating the Freundlich equation coefficients are unnecessary.

5.2.5.3. Region II: Adsorption at Medium Doses. The adsorption of organics at medium GAC doses as illustrated in Figures 5.9 through 5.13 is analyzed in detail in Figure 5.14, Figure 5.15, Figure 5.16 and Figure 5.17. The Freundlich constants obtained by regression analyses are presented along with their 95% confidence intervals in Table 5.4.

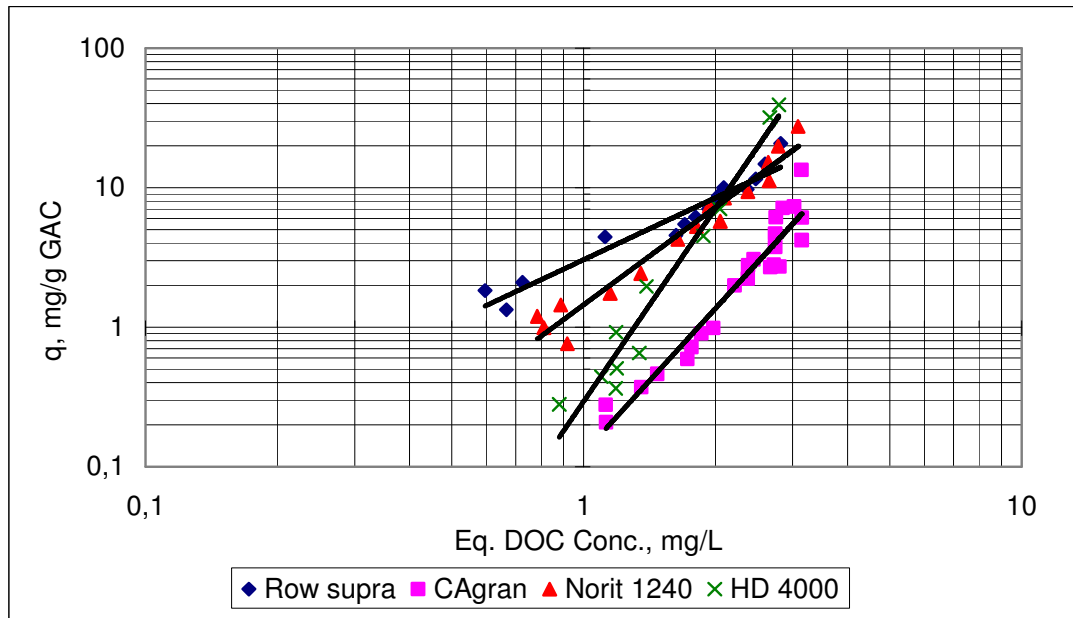


Figure 5.14 Freundlich adsorption isotherms belonging to II. Region (Adsorption at medium doses) for raw water

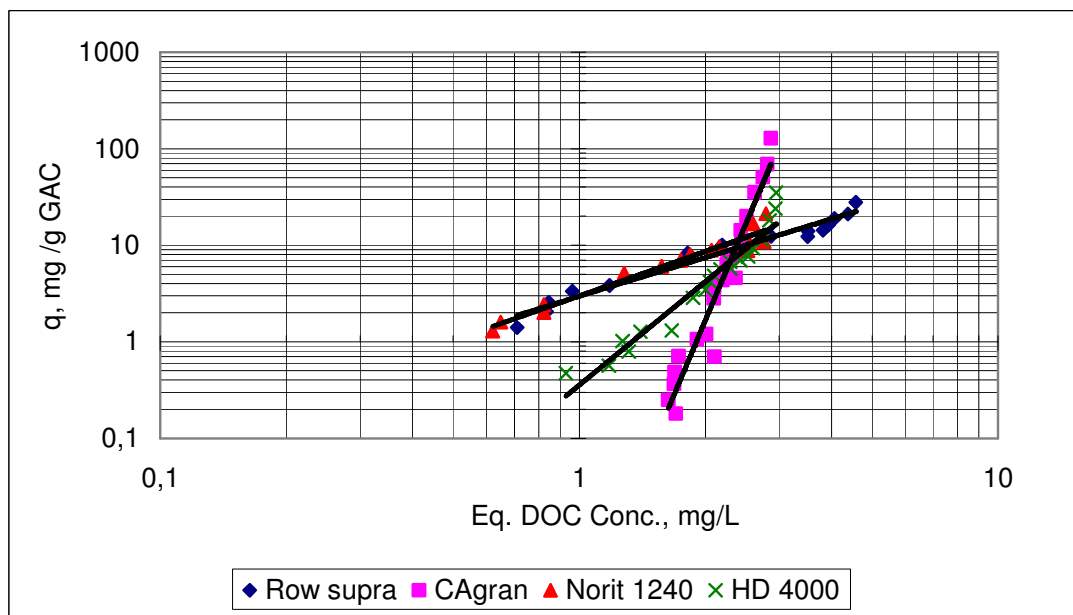


Figure 5.15 Freundlich adsorption isotherms belonging to II. Region (Adsorption at medium doses) for ozonated water

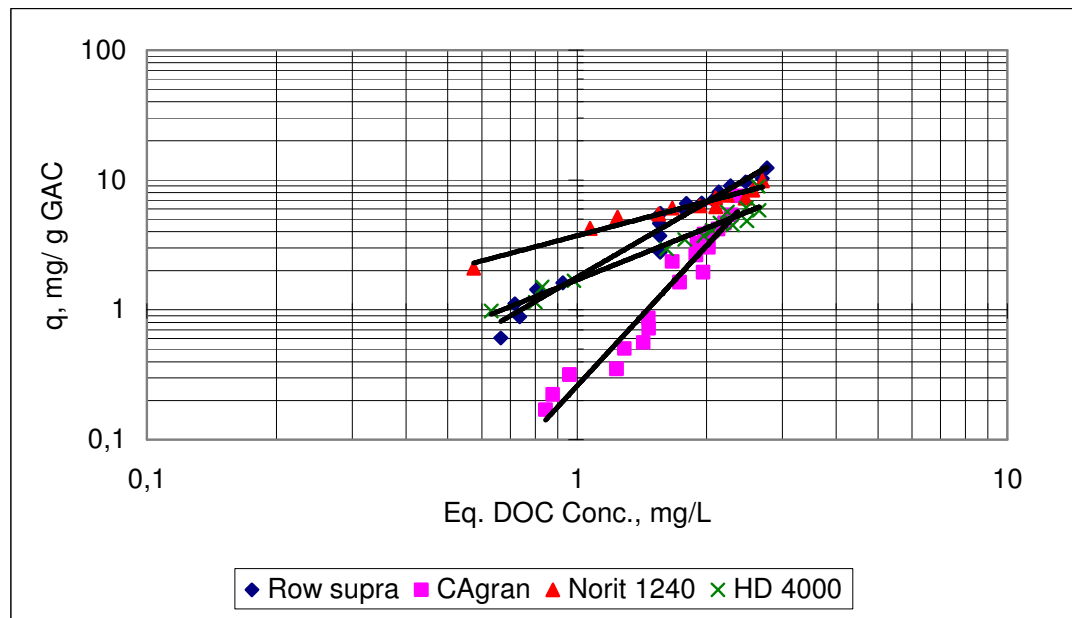


Figure 5.16 Freundlich adsorption isotherms belonging to II. Region (Adsorption at medium doses) for biologically treated water

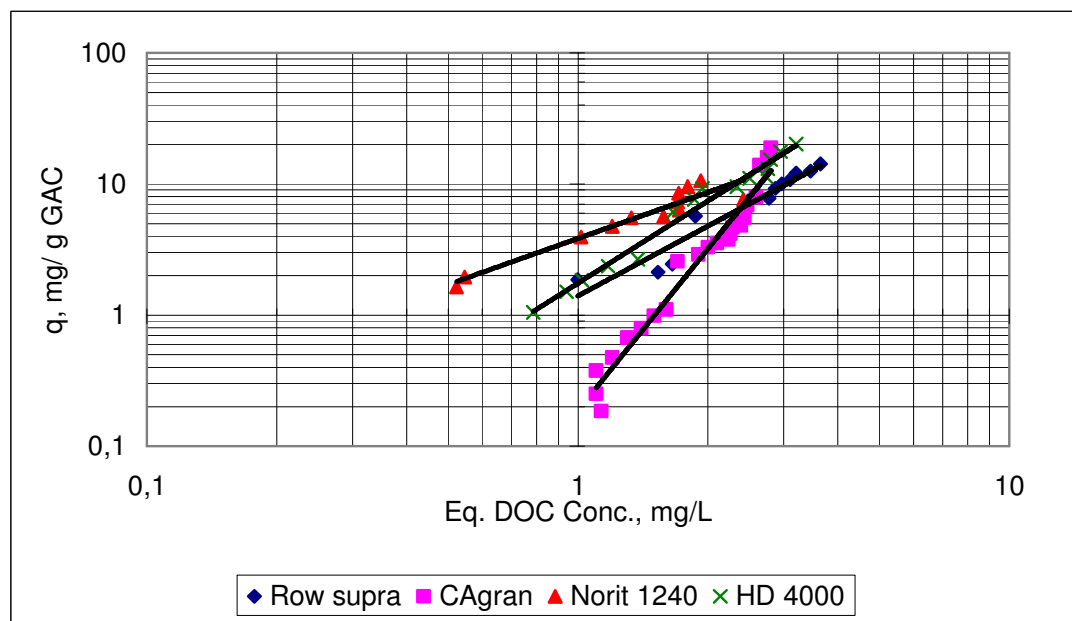


Figure 5.17 Freundlich adsorption isotherms belonging to II. Region (Adsorption at medium doses) for ozonated - biologically treated water

The chemically activated wood-based CAgran showed the lowest adsorption of NOM. This may be due to weaker electrostatic interactions of the surface with organic matter or more oxygen-containing surface groups with respect to other steam activated carbon types. Hence, chemically activated carbons provide a pore surface which is less hydrophobic and more negatively charged. In the present study it was shown that both NOM and the CAgran surface are negative (Figure 5.6 and Figure 5.7) and therefore adsorption of NOM onto CAgran was unfavorable.

Table 5.4 Freundlich adsorption isotherm constants belonging to II. Region: Adsorption at medium doses

GAC Type	K_f	1/n	R^2
Raw Water			
Row Supra	2.96±0.09	1.51±0.13	0.94
CAgran	0.13±0.004	3.44±0.41	0.93
Norit 1240	1.45±0.10	2.32±0.11	0.96
HD 4000	0.29±0.01	4.32±0.39	0.93
Ozonated Water			
Row Supra	2.96±0.25	1.33±0.17	0.96
CAgran	0.001±0.002	10.34±0.82	0.94
Norit 1240	2.98±0.17	1.53±0.31	0.95
HD 4000	0.36±0.10	3.56±0.34	0.95
Biologically Treated Water			
Row Supra	1.79±0.10	1.92±0.29	0.97
CAgran	0.26±0.03	3.59±0.15	0.94
Norit 1240	3.73±0.26	0.87±0.03	0.95
HD 4000	1.70±0.12	1.33±0.12	0.96
Ozonated - Biologically Treated Water			
Row Supra	1.40±0.21	1.77±0.28	0.93
CAgran	0.19±0.04	4.12±0.51	0.97
Norit 1240	3.85±0.43	1.17±0.17	0.92
HD 4000	1.76±0.18	2.08±0.22	0.98

There is a noticeable link between adsorption and surface chemistry; the most positively charged carbon should be the most proficient in adsorbing negatively charged NOM. This theory is supported by the data in that Norit 1240 and Row Supra are better adsorbers of NOM than HD 4000 and CAgran. On the other hand, the pore volume is also an important parameter for NOM adsorption when the size of the activated carbon pores is similar in size to the NOM molecules (Moore, 2000). As micropores are too small for an

average NOM molecule to fit, mesopores can be very important when adsorbing NOM (Newcombe et al., 1993; Donati et al., 1994; Newcombe et al., 1996; Newcombe et al., 1997, Moore et al., 2001). CAgran has the highest total pore volume (especially high meso and macro pore volumes), which should make it suitable for adsorbing NOM molecules. However, its lower adsorbability demonstrates that pore volume is a poor indicator of adsorbent's performance within the scope of this study, compared to surface charge. In the present study, Norit 1240 and Row Supra were the two most efficient adsorbents for all water types.

For example, Newcombe et al. (1994) adsorbed NOM onto 10 activated carbons at pH 3 and found a linear relationship between mesopore volume (width 2–50 nm) and adsorption capacity, clearly demonstrating that the main factor influencing adsorption under the chosen conditions was the volume of pores in the appropriate size range. The factors influencing adsorption were the same, per volume of mesopores, for each carbon and were most likely due to hydrophobic attraction. At pH 7, where the negative charge of the NOM was large, electrostatic interactions became significant, resulting in much decreased adsorption and no direct relationship between mesopore volume and adsorption of NOM was found.

For CAgran, adsorption became even more unfavorable, compared to raw water when the water was ozonated. There may be several reasons for this result. The negative charge of NOM further increased in ozonated water (Figure 5.6) and the net surface charge of CAgran varies from positive at pH <4.2 to negative values at higher pHs (Figure 5.7). Therefore, a bigger repulsive force between the NOM and carbon surface might have decreased the NOM adsorption at neutral pH values. Molecular size reduction upon ozonation may also play a role in decreasing the adsorption capacity. Due to its more macroporous structure, CAgran might have failed to adsorb lower molecular weight organics to a greater extent. Therefore, the size incompatibility between the carbon and NOM might have further decreased the adsorption efficiency.

For biologically treated water samples, adsorption onto CAgran and HD4000 was slightly improved. The surface charge of CAgran and HD4000 is negative at the water pH of 7.6. BDOC seemed to contribute most to the negative charge. Removal of BDOC by

biological means as in the case of biologically treated water and ozonated-biologically treated water (Figure 5.6) leaves the nonbiodegradable portion in water. In such cases, the net negative charge of NOM decreased compared to raw and ozonated water. Therefore, the repulsion force between GAC and NOM is weaker in the presence of nonbiodegradable organics and hence adsorption improved. In contrast to this, in waters with a high BDOC level it is likely that adsorption onto CAgran and HD4000 (negatively charged) is affected negatively.

Additionally, in biologically treated samples the solution contains larger molecules since smaller molecular weight biodegradable organics have been removed. Examining Table 3.1 shows that both CAgran and HD 4000 have open structures, which are mainly meso and macro pores. As large molecules tend to adsorb onto macro pores easily, this may explain why adsorption onto these carbons is relatively favorable.

In order to investigate the role of surface chemistry of GAC on DOC removal, adsorption behavior was correlated to acidic surface functional groups. Surface acidity was studied via Boehm titrations, while adsorption was evaluated using the Freundlich constant, K_f . The Pearson's product momentum correlation coefficient (r_p) for the relationship was used for linear estimation of the strength and direction of the correlation. The relationship was depicted in Figure 5.18.

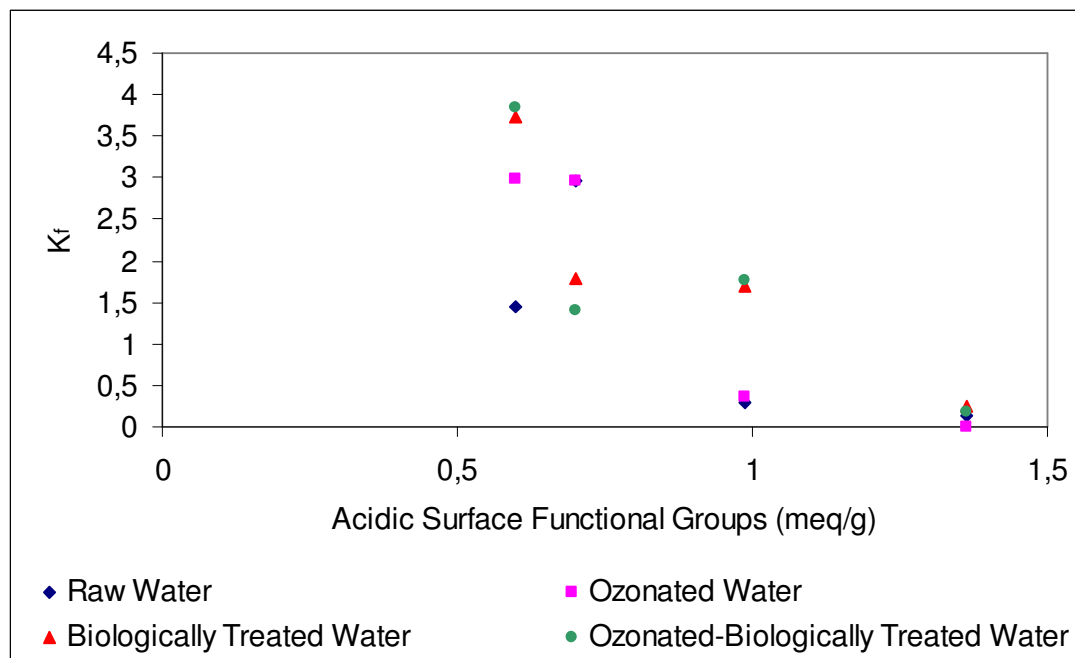


Figure 5.18 Relationship between the acidic surface functional groups and adsorption

Indeed, in both water samples the presence of acidic functional groups lowered the adsorption capacity, K_f , as illustrated in Figure 5.18. The overall Pearson coefficient determined at 95 % confidence interval (-0.84) indicated a moderate correlation between adsorption and surface acidity. The net result was that the adsorbents with higher pH_{PZC} (Norit 1240 and Row Supra) (Figure 5.7), exhibited the largest NOM adsorption capacity for all water types tested. However, a satisfactory relationship was not found between adsorption capacity and the total pore volume or BET surface area parameters.

5.2.5.3. Correlation between the UV absorbance and DOC Results. Some researchers have evaluated the use of surrogate parameters as indicators of other water quality parameters that are more difficult to measure and they have shown that UV absorption may have a strong correlation with organic carbon content, color and precursors of trihalomethanes and other disinfection by-products. The correlation between DOC and UV_{254} was investigated using the data from raw water and from adsorption equilibrium tests.

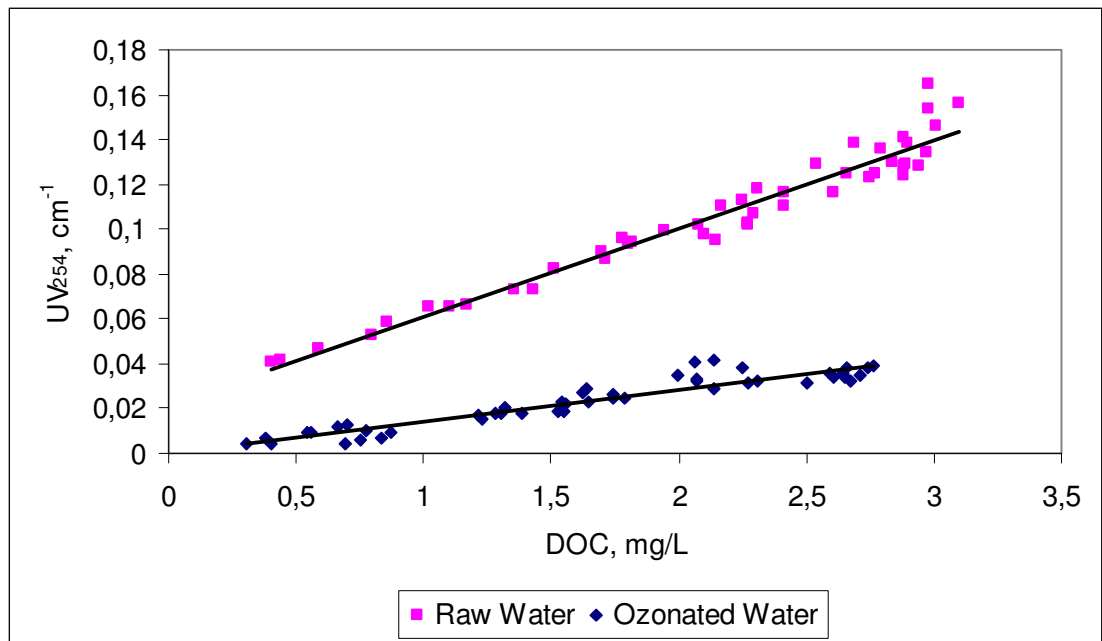


Figure 5.19 Correlation between the DOC and UV₂₅₄ in raw and ozonated water

A good correlation exists between the UV₂₅₄ absorbance and the DOC concentration both in raw water and ozonated water as noted in Figure 5.18. The Pearson's product momentum correlation coefficient (r_p) for the relationship was used for linear estimation of the strength and direction of the correlation. A strong positive correlation with an $r_p=0.95$ was obtained for ozonated water, $r_p=0.97$ was obtained for raw water from the results of the measurements. The relationships between these parameters were, however, different for raw and ozonated water. For this reason, these parameters can only be substituted for each other for the same water type (i.e., raw water or ozonated water).

5.2.6. Desorption Isotherms

Desorption of biodegradable organics in biologically active granular activated carbon columns is desirable, since it leads to subsequent biodegradation in biofilm and hence to renewal of adsorption capacity. Therefore, irreversible adsorption onto activated carbon is especially important in systems like biological activated carbon where adsorption is coupled with biodegradation. The reversibility of adsorption is measured with desorption.

Desorption isotherms for different water samples and GAC types are presented in Figures 5.20, 5.21, 5.22 and 5.23. In these tests, the loaded carbons from adsorption tests were used. However, only the four lowest GAC concentrations were used to construct the desorption isotherms and maximum percent desorptions. This is because when the surface loading on activated carbon is low (i.e., in the case the adsorption sites are only partially used at high GAC concentrations), a higher fraction of the sorbed material will be irreversibly adsorbed due to high energy reactions occurring on the surface.

Percent desorption of a loaded carbon can be a good indicator for the reversibility of adsorption. It shows the percent change of NOM loading on GAC after desorption. The percent desorption was maximum at the lowest GAC concentration for all carbon types and water samples used. For raw water, the maximum percent desorption for CAgran, HD 4000, Row Supra and Norit 1240 were 51 %, 38 %, 24 % and 4 %, respectively. The percentage of NOM desorbed increased for ozonated water for all GAC. It was 58 %, 39 %, 36 % and 29 % for CAgran, HD 4000, Row Supra and Norit 1240. For biologically treated water, 47 %, 31 %, 30 % and 15 % percent desorptions and for ozonated – biologically treated water samples 49 %, 33 %, 31 % and 20 % percent desorptions were observed for CAgran, HD 4000, Row Supra and Norit 1240, respectively. The results showed that, CAgran exhibited the highest desorption of adsorbed organic matter, while HD4000 was the second most efficient. Norit 1240 and Row Supra had relatively irreversible adsorption.

Desorption isotherms were constructed based on the DOC loading still remaining on the GAC surface. Thus, a higher surface loading on carbon following the desorption experiment is an indicator of inferior desorption. Figure 5.20, 5.21, 5.22 and 5.23 shows desorption equilibrium DOC concentrations and the surface loading remaining on the carbons.

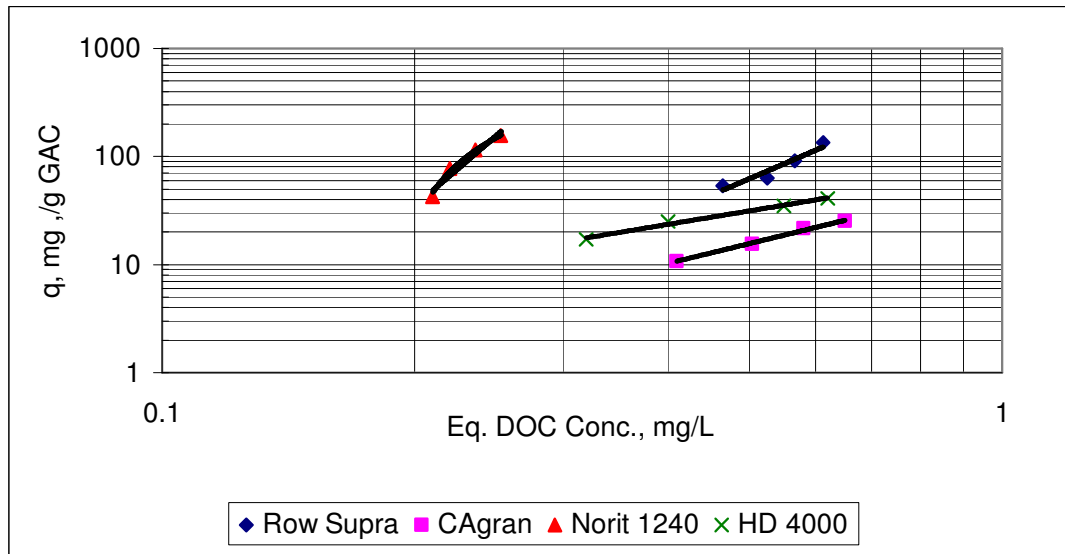


Figure 5.20 Desorption isotherms for raw water

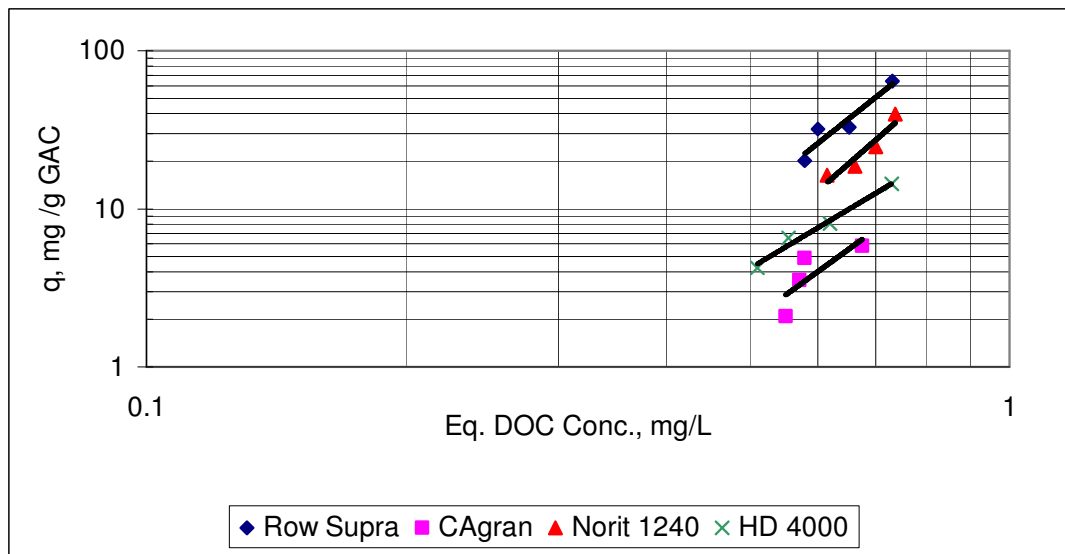


Figure 5.21 Desorption isotherms for ozonated water

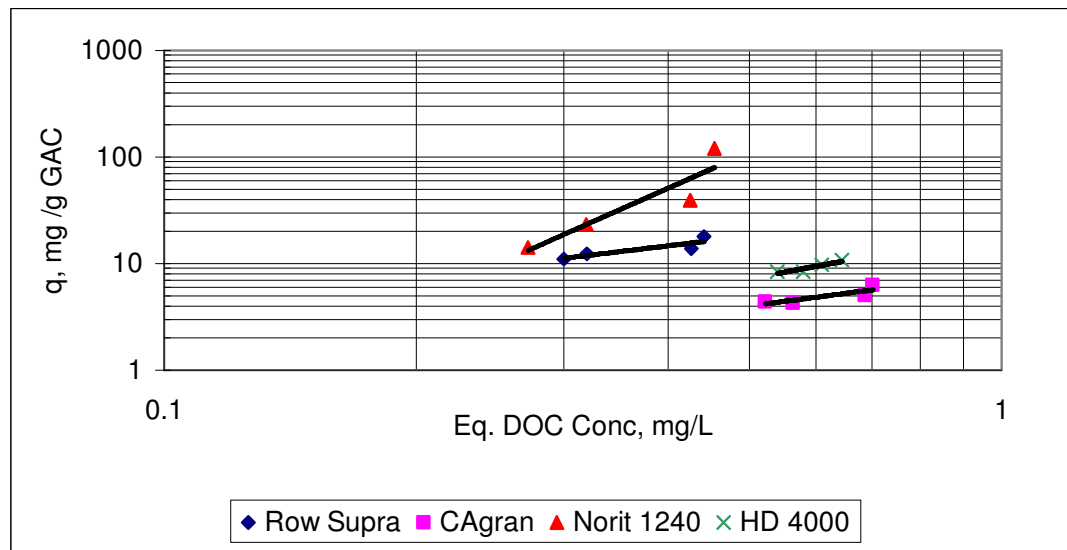


Figure 5.22 Desorption isotherms for biologically treated water

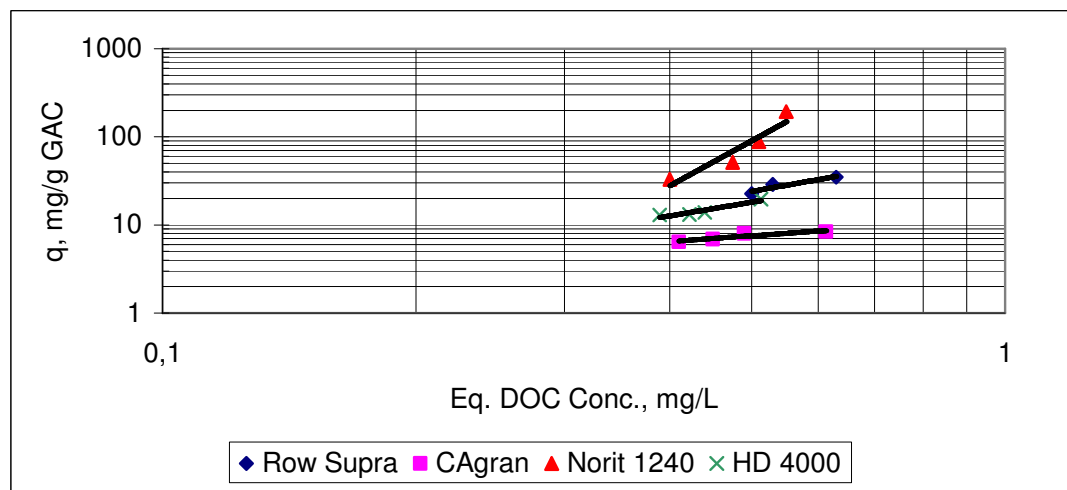


Figure 5.23 Desorption isotherms for ozonated - biologically treated water

Desorption isotherm constants are presented in Table 5.5. The reversibility of adsorption is limited for all carbon types. The results of desorption isotherms were similar to results of the percent desorption.

Table 5.5 Freundlich desorption isotherm constants

GAC Type	K_f	1/n	R^2
Raw Water			
Row Supra	634.72	3.35	0.92
CAgran	58.06	1.89	0.99
Norit 1240	2E+6	6.69	0.94
HD 4000	76.63	1.29	0.98
Ozonated Water			
Row Supra	239.78	4.34	0.90
CAgran	30.45	3.96	0.84
Norit 1240	151.18	4.79	0.89
HD 4000	40.37	3.27	0.98
Biologically Treated Water			
Row Supra	34.86	0.94	0.88
CAgran	8.19	1.03	0.83
Norit 1240	1257.10	3.49	0.84
HD 4000	20.14	1.48	0.82
Ozonated - Biologically Treated Water			
Row Supra	77.42	1.68	0.87
CAgran	11.96	0.67	0.85
Norit 1240	3447.9	5.26	0.89
HD 4000	55.06	1.60	0.90

The pH_{PZC} may play a role in desorption. Desorption isotherms were conducted in deionized water (without any pH adjustment) at a water pH around 6. The surface charge of CAgran becomes less negative at that pH value. Even though the repulsion forces are weaker compared to that of adsorption experiments, repulsion between the negatively charged NOM and the negatively charged surface may still occur, thus making desorption easier. The charge of HD4000 is nearly neutral at pH 6. As the electrostatic attractions at this pH are lower for HD4000 than in the case of Norit 1240 and Row Supra, the desorption may be better.

In the same manner, desorption is easier from macropores when compared with micro and mesopores (Karanfil and Dastgheib, 2004). The high ratio of macro pores in CAgran and HD4000 may make desorption easier from these carbons.

The major conclusions from adsorption and desorption experiments were as follows:

- The surface chemistry of carbon played an important role in adsorption of NOM. GAC types with higher pH_{PZC} (Norit 1240 and Row Supra) exhibited the largest

NOM adsorption capacity in water samples because of the electrostatic attractions between GAC and the negatively charged NOM. In general, the adsorption results indicate that the surface chemistry of GAC is more influential than pore structure.

- Despite the fact that chemically activated carbon CAgran had inferior adsorption compared to thermally activated carbon in all water samples, it showed better desorbability among the GACs tested. These results may be a key to choosing the optimum GAC type to be used for different applications. If the only aim is to adsorb the NOM from raw water, then one of the thermally activated carbons with high pH_{PZC} such as Row Supra or Norit 1240 can be chosen for treatment. If the aim is to couple adsorption with biodegradation such as in a biological activated carbon (BAC) process, then the right option is to choose a GAC providing a high desorption of biodegradable organics. Desorption of such compounds would result in enhanced adsorption capacity of GAC for nonbiodegradable compounds. While CAgran has the highest desorption, the study clearly demonstrated that adsorption onto CAgran was worse following ozonation. Therefore, the usage of CAgran in such a process, where ozonation is usually integrated into the BAC process, is inconvenient. HD4000 may be a likely alternative as its adsorption is better than CAgran and it has the second highest desorption among the four carbons.

The main findings in this chapter were accepted for publication in the Journal of Environmental Engineering Science (Yapsaklı et al., 2008).

5.3. Optimization of BDOC Measurement

Biodegradable dissolved organic carbon (BDOC) measures the amount of dissolved organic carbon (DOC) that is biodegradable. The original batch BDOC method (Servais et al., 1987) uses a highly acclimated inoculum originating from the same environment as the water sample (indigenous inoculum). To satisfy the requirement, the water sample is filtered and inoculated with the sample itself. Compared with biochemical oxygen demand (BOD), the BDOC procedure is relatively new but quite similar in principle. The only key difference is that instead of dissolved oxygen, DOC is measured before and after incubation in the BDOC procedure. BDOC is more accurate, precise, and sensitive than BOD (Khan et al., 1998).

There have been a number of modifications to the original BDOC method, but few have repeated application or uptake. These modifications are summarized in Table 5.6.

Table 5.6 Modifications to the original BDOC method

Improvement Sought	Modification	Reference
Original Method	Standardized BDOC method based on the measurement of DOC	Servais et al., (1987)
Increase size of measured BDOC pool	Use of attached bacteria	Park et al, 2004
	Increase incubation time	McDowell et al, 2006
Increased speed	Use of attached bacteria	Trulleyova and Rulik, 2004; Park et al, 2004
	Use of a plug reactor	Volk et al, 1997

The use of water sample as a BDOC inoculum has several drawbacks. Most water samples do not contain a sufficient initial number of microorganisms. For this reason, an incubation period of 28 days is required for the procedure. Furthermore, the inoculum may

not provide maximum possible BDOC exertion due to limited microbial diversity. Therefore, the usage of an acclimated culture in the BDOC test could result in more correct measurements. Use of attached bacteria could also be used for this purpose, but it has also some drawbacks. Firstly, it is difficult to accomplish complete cleaning of the sand, which in turn affects the DOC detection level. Second, the bacterial products which are excreted as a result of cell lysis can be a big problem in measurement, especially when low BDOC samples are tested.

In this study, instead of using the water sample itself as an inoculum as in the original BDOC test, the bacteria that were grown on a suspended growth system were used. The indigenous bacteria in Ömerli water were enriched by supplementing oxygen and by feeding the system with biodegradable substances like glucose and acetate at varying concentrations. At later stages, bacteria were only fed with Ömerli water so bacteria utilize only the organic carbon of Ömerli as carbon source. Therefore, the suspended growth system contains bacteria that originate from the reservoir and are acclimated to both readily and slowly biodegradable DOC in the reservoir. It is expected that bacteria produced special enzymes to treat organics which are hard to biodegrade. It is therefore, the purpose of this chapter to test the performance of the BDOC seed which are taken from this suspended growth system.

5.3.1. BDOC Exertions of Standard Solutions

When the bacteria concentration in the inoculum is high, cell lysis can occur during the BDOC procedure. This occurs because the cell contents become soluble after cell lysis, which in turn increase the DOC concentration in the solution. In this case, measured BDOC value is lower than the actual value. Since the bacteria concentration is high in the suspended growth culture compared to the original seed of the BDOC test, different seeding ratios should be tested in order to avoid such situations. In the original procedure, a ratio of 1:100 (v/v, 1 ml seed is added into 100 ml water sample) is used. In the current study, different seeding ratios like 1:100, 1:250 and 1:500 were tested to determine the optimum seed ratio. First, the seed was tested on standard solutions of acetate which is known to be easily biodegraded. Acetate solutions with varying concentrations namely, 1 mg/L, 2.5 mg/L and 5 mg/L were tested. In addition to using the seed from the batch

reactor, the indigenous seed from the reservoir (Ömerli water which has been filtered through 2 μm) was also tested. BDOC was measured in duplicate for each sample and inoculum tested. The results are presented in Figure 5.24, Figure 5.25 and 5.26.

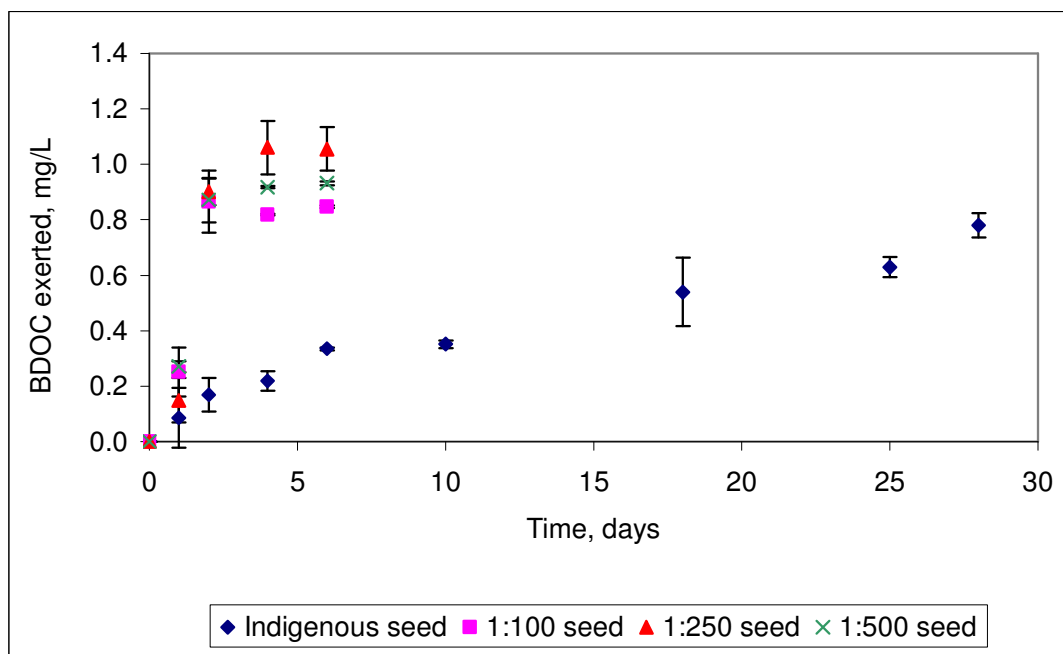


Figure 5.24 BDOC exertion for 1 mg/L Acetate-C

Figure 5.24 presents the average BDOC exertion resulting from different inocula ratios versus incubation time for standard solutions with initial DOC of 1 mg C/L. BDOC exerted using the acclimated seed reached the maximum BDOC value (i.e., 1 mg C/L) within three days of incubation time for all seeding ratios tested. Therefore, the seed contained a sufficient amount of active bacteria to degrade the organic matter even at a seed ratio of 1:500. The original seed coming from the Ömerli water itself required a much longer incubation time than the acclimated seed. Moreover, even in the 28 days of incubation time, it did not provide complete BDOC exertion. 78 % of the acetate- carbon could be biodegraded at the end of 28 days. This shows that, bacteria in Ömerli water were not in sufficient amounts to degrade even a readily biodegradable substrate like acetate.

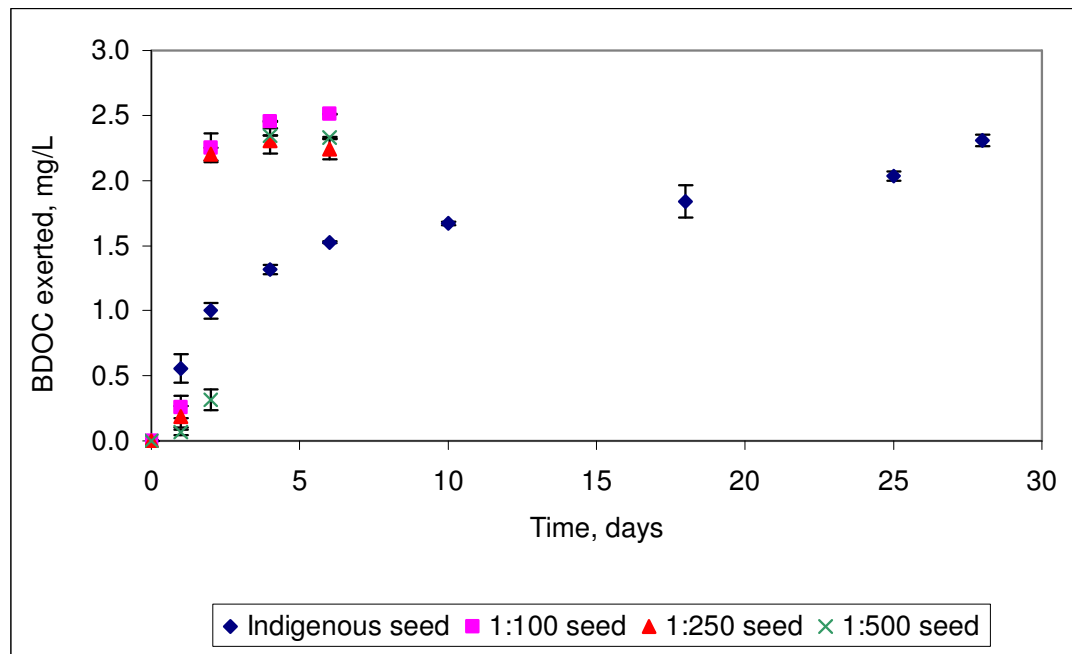


Figure 5.25 BDOC exertion for 2.5 mg/L Acetate-C

When the acetate-carbon concentration was increased to 2.5 mg C/L, the acclimated seed again provided complete BDOC exertion within three days, whereas the indigenous seed required 28 days to biodegrade the acetate. It is evident that the indigenous seed had a slower response than the acclimated seed. Based on exertion trends, the indigenous seed has the degradation ability; however, a higher inoculum dose and/or more time are required for complete exertion. The rate of substrate utilization at 2.5 mg C/L was higher compared to 1 mg C/L which is an expected result when working with low substrate concentrations.

Figure 5.26 shows the BDOC exertion trends when the acetate-carbon concentration was 5 mg C/L. Similar to previous results, complete BDOC exertion was seen within three days when acclimated seed was used. On the other hand, 10 days was required for the complete exertion when indigenous seed was used.

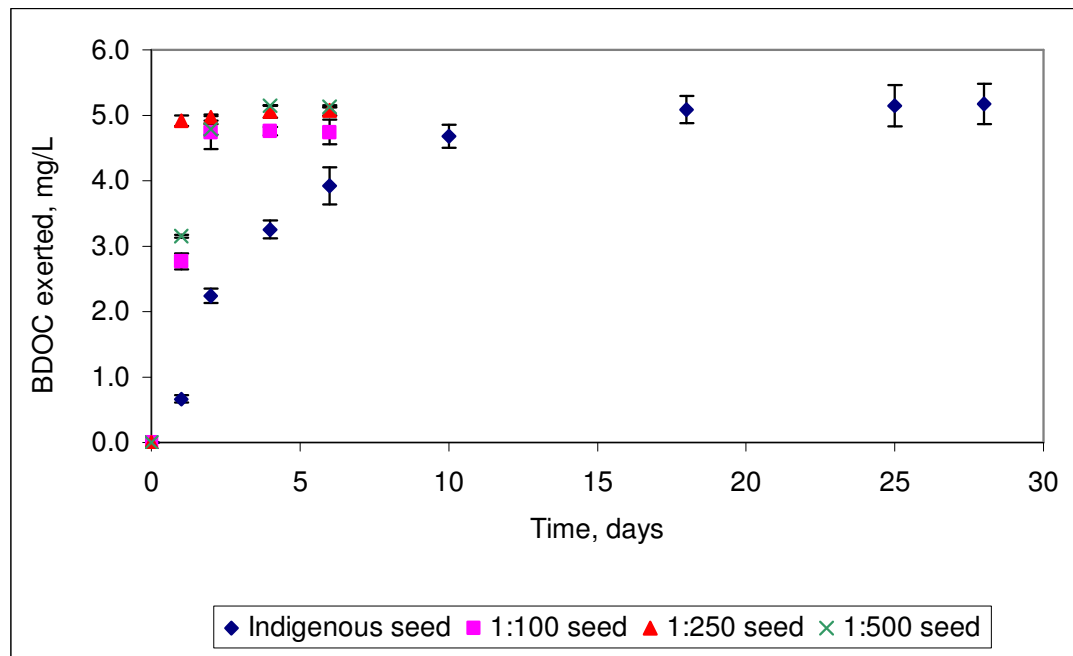


Figure 5.26 BDOC exertion for 5 mg/L Acetate-C

Results suggest that the acclimated seed could completely biodegrade acetate at both low and high concentrations in a reasonable time. Even a 1:500 seed ratio contains enough microorganisms to degrade acetate at the same time with higher ratios. On the other hand, the bacteria concentration in the Ömerli water was limited, this had a strong influence on biodegradation rates. The indigenous seed of Ömerli reservoir failed to completely biodegrade acetate at a concentration of 1 mg C/L. Increase in acetate concentration resulted in relatively faster biodegradation rates when indigenous seed was used. This means that when the substrate was limiting in solution, biodegradation rate decreased.

5.3.2. BDOC Exertions of NOM Samples

BDOC test was repeated for the same seeding ratios for both raw water and the ozonated water of Ömerli reservoir. Ozonation was applied at a rate of 2 mg O₃ /mg DOC the reasons of which were explained in detail in Section 5.1.4. The average BDOC concentrations resulting from different inoculum ratios versus incubation time for raw water samples with an initial DOC of 5.18 mg/L are presented in Figure 5.27.

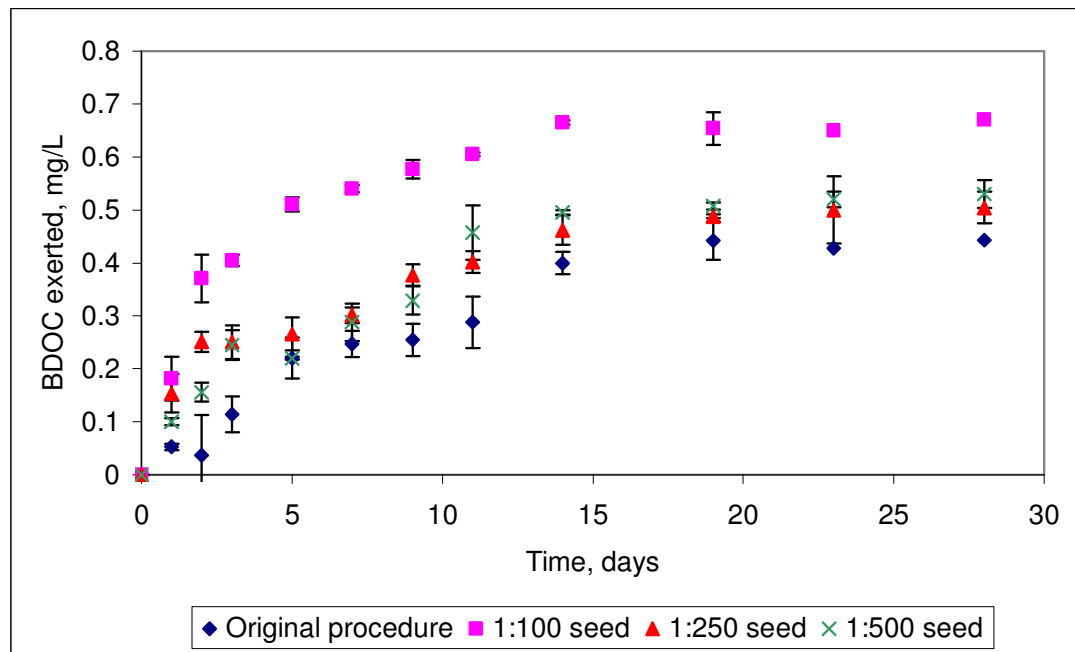


Figure 5.27 BDOC exertion for the raw water samples

A seeding ratio of 1:100 offered higher BDOC exertion than other ratios. This means that the amount of bacteria was not enough to achieve the same ultimate BDOC values. Moreover, when the BDOC test was done according to the original procedure, this resulted in about 33 % lower BDOC readings. This indicates that there was a portion of DOC that could be degraded by the acclimated bacteria but not the indigenous inocula. This was an expected result since the indigenous seed was not as acclimated as the other three inocula. The average ultimate BDOC exertion for the acclimated seed was 13 %, 10 % and 9.8 % when a seeding ratio of 1:100, 1:250 and 1:500 were used, respectively. BDOC results of different seeding ratios were found to be statistically significant which was determined using ANOVA and according to 95% confidence interval. In the original procedure this percentage of biodegradable substrate was as low as 8.3 %.

The average BDOC concentrations resulting from different inoculum ratios versus incubation time for ozonated water samples with an initial DOC of 5.05 mg/L are presented in Figure 5.28.

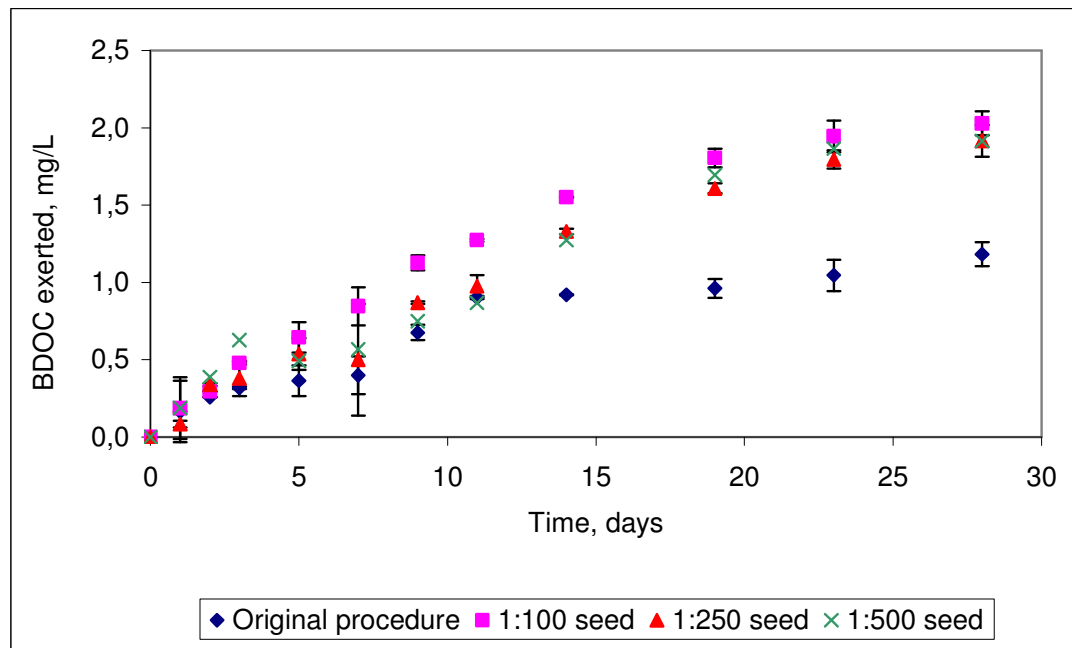


Figure 5.28 BDOC exertion for the ozonated water samples

In ozonated water samples, all seeding ratios resulted in similar BDOC exertions. This was also observed in statistical significance tests. The BDOC exertions were found to be statistically insignificant in all ratios. On the other hand, when the BDOC test was done according to the original procedure, this resulted in about 42 % lower BDOC readings. The average ultimate BDOC exertion for the acclimated seed was 36.0 %, 35.7 % and 35.4 % when a seeding ratio of 1:100, 1:250 and 1:500 were used, respectively. In the original procedure this percentage of biodegradable substrate was as low as 21 %.

These results show that, using an acclimated seed resulted in better BDOC readings than the original procedure. Moreover, a seeding ratio of 1:100 was found to be the best alternative among others tested. Therefore, this modification was used throughout the study.

5.4. Continuous-Flow Column Experiments

Continuous-flow BAC experiments were conducted in lab-scale columns to simulate full-scale adsorption and biodegradation. In the scope of continuous-flow column experiments, both carbon removal and nitrification was studied. The effect of activated carbon type on the enhancement of biodegradation was investigated in systems fed both with raw water and ozonated water. The nitrification performances were tested and the active nitrifying species in the columns were determined.

5.4.1. Enrichment of Inoculum for BAC Columns

Full-scale experiments have shown that for an initially biomass-free media in the biofilter, at least 1 month is necessary to capture and grow a sufficient amount of heterotrophic and nitrifying bacteria to reach the desired removal efficiency. In addition, it is necessary to wait for biofilter colonisation before using the water for production. Consequently, a high quantity of water is lost during these periods. Improving the start-up of bio-filters at low substrate concentration is therefore, a major challenge related to the drinking water industry.

In order to enhance and accelerate the start-up of biological activity inside biological activated carbon columns, it was determined to inoculate bacteria into the system. The concept of inoculation into GAC columns to make them biologically active is not new. For example, in the study of Mochizuki and Takeuchi (1999), microorganisms grown in an activated sludge tank (MLSS = 2100-3500 mg/L) were employed as a “starter” for the biofilm. Zhao et al. (1999) inoculated the pilot-scale reactor with a mixed culture obtained from a laboratory-scale fluidized bed reactor that had been supplied with toluene as the sole carbon source for a year. In a study conducted by Nishijima and Speitel (2004), in order to clarify the fate of BDOC in the BAC columns, inoculum was added to granular activated carbon filters. Both columns were inoculated with 50 mL of inoculum, which was circulated into each column at an empty bed contact time (EBCT) of 30 min for 24 h. Unfortunately, the source of the inoculum was not given in the study. Similarly, in a recent study by Traenckner et al. (2008), one of the columns was inoculated with 60 L backwash water from a nitrifying rapid sand filter, to enhance the start-up of nitrification. On the

other hand, in the second column a part of filter material was replaced with the 7000 g of filter material of the same nitrifying rapid sand filter. An activated sludge MLVSS was also used as inoculum by some researchers, but there is a probability that the culture contains pathogens. It was thought that pathogens should not be inoculated to a system which serves as drinking water purposes. In the current study, therefore, bacteria in the Ömerli water were enriched for three months in a suspended culture batch reactor, so that the inoculum in BAC system contained bacteria that originate from the reservoir itself and were acclimated for organic carbon of the source. This way, from the first day of the operation, the columns were biologically active and biodegradation and adsorption took place simultaneously.

Four months prior to start-up of the columns, a four liter batch reactor was set to enrich the bacteria in Ömerli water. Enrichment was done by feeding the system with acetate and glucose as a carbon source. Ömerli water was added to the reactor every day and acetate and glucose were spiked into water. Therefore mineral supplementation to the solution was not required. The influent and effluent DOC profiles of the batch reactor between days 0-40 were depicted in Figure 5.29.

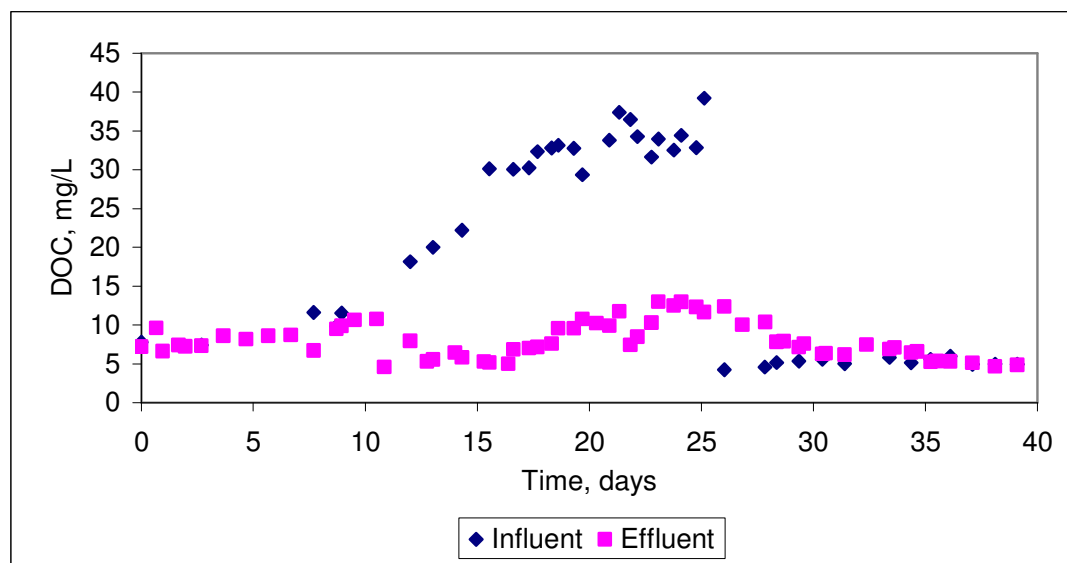


Figure 5.29 Daily influent and effluent DOC profiles of the batch reactor between days 0-40

For the first ten days of reactor operation, despite acetate and glucose additions, no biodegradation was observed. From this time on, the organic carbon was increased on a regular basis from 10 mg C/L to 40 mg C/L to increase bacterial growth. Between days 10 and 25, there was a noticeable increase in biodegradation efficiency. The maximum biodegradation efficiency of the system was 83 %. MLVSS concentration at Day 25 increased up to a maximum value of 140 mg/L at Day 25. At this point, organic carbon addition was stopped and the reactor was fed only with a mixture of Ömerli raw and ozonated water.

Because the organic carbon in the Ömerli water is lower compared to previous days, cell lysis was expected in the system. This was why the influent DOC was lower than the effluent DOC in the subsequent ten days. At the end of 40 days the influent and effluent DOC concentrations were not different from each other. The influent and effluent DOC profiles between days 40-140 are presented in Figure 5.30.

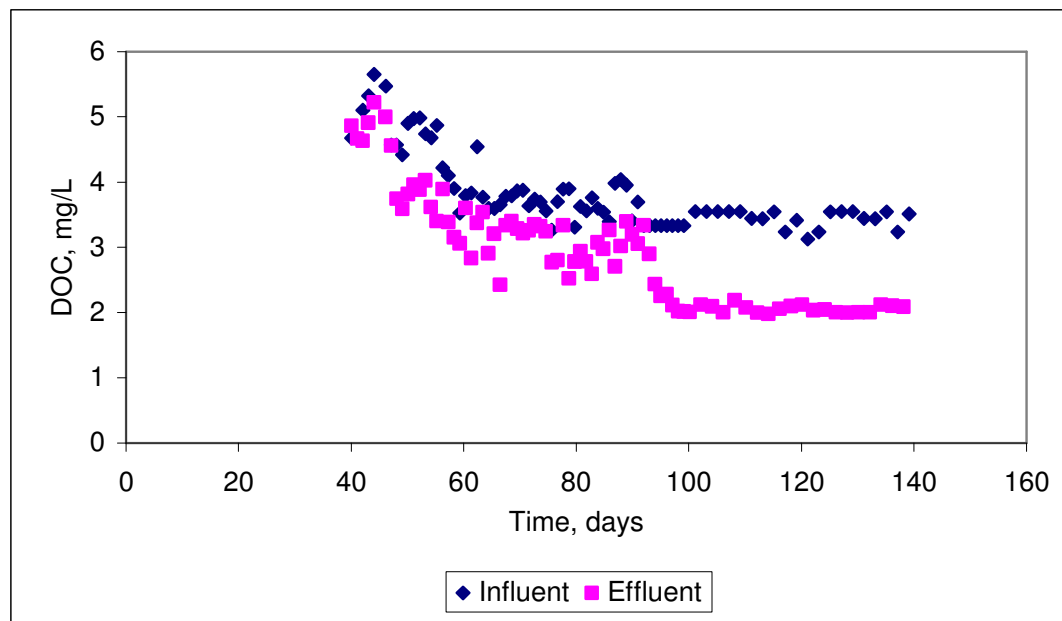


Figure 5.30 Daily influent and effluent DOC profiles of the batch reactor between days 40-140

Between days 40-60, the influent DOC decreases due to the change in raw water quality which may occur during a turnover in the lake. The average DOC removal was

20% at this time period. Between days 100-140, the system was fed with ozonated water only. In this case, the biodegradation efficiency increased up to 40 %. This is because the BDOC of ozonated water is higher compared to raw water. The average influent and effluent DOC concentrations in this period were 3.5 mg/L and 2.0 mg/L, respectively. The influent BDOC concentration in ozonated water was 1.2 mg/L. This means that, the DOC bio-removal in the reactor was slightly higher than the biodegradable DOC in the influent which was quantified by the BDOC test. This is an expected result since the reactor offers a more suitable environment for substrate degradation than that of BDOC test (e.g. higher bacteria concentration, good mixing conditions etc.).

The reactor was also fed with $\text{NH}_4^+\text{-N}$ on a daily basis to enrich nitrifiers. Figure 5.31 shows the $\text{NH}_4^+\text{-N}$ removal performance of the batch reactor.

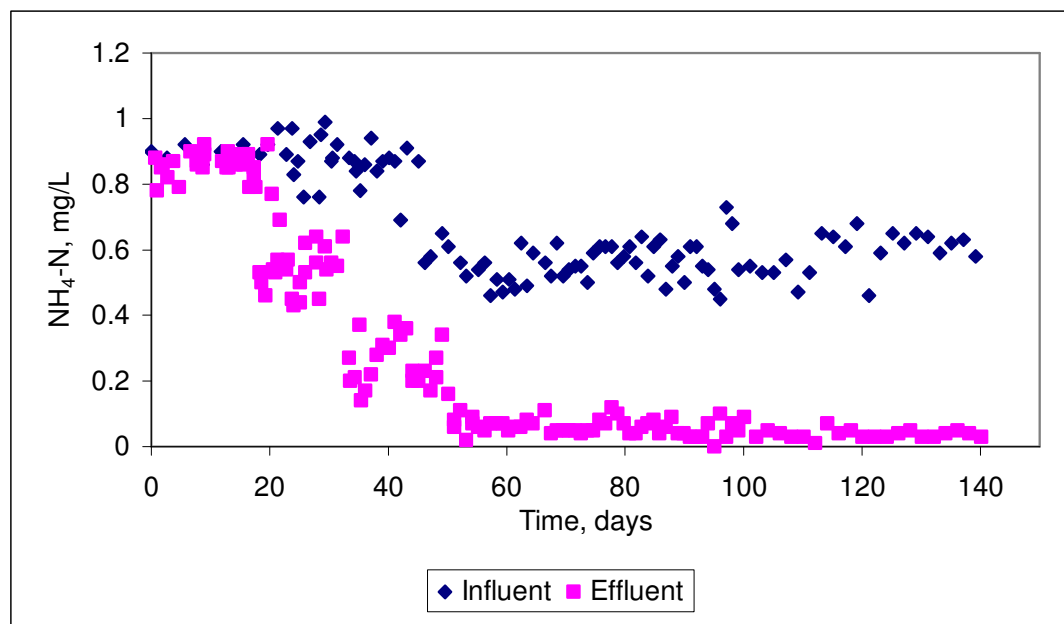


Figure 5.31 Daily influent and effluent $\text{NH}_4^+\text{-N}$ profiles of the batch reactor

During the first 50 days of operation, reactor was fed with 0.9 mg/L $\text{NH}_4^+\text{-N}$. On the other hand, no ammonium nitrogen removal was observed in the first 20 days. During this period, it was assumed that nitrifiers grow and reproduce in the system and acclimate to the environment. Between days 20-50, there was a gradual decrease in the effluent $\text{NH}_4^+\text{-N}$ concentration and afterwards, the system became stable in terms of $\text{NH}_4^+\text{-N}$

removal. The influent concentration was then decreased to 0.6 mg/L $\text{NH}_4^+\text{-N}$. This was a predetermined value for the influent concentration of continuous-flow BAC columns. For the last 80 days, 95 % of the influent ammonium was removed in the system.

At Day 140, bacteria in the reactor were used as an inoculum for the activated carbon columns. The MLVSS concentration at the day of transfer was 70 mg/L. Each of the two GAC types in the column experiments were contacted with 2 L of bacterial solutions using a mechanical shaker overnight. Afterwards, the mixture was transferred to each of the columns. Therefore, the bacterial concentration is more or less the same at all depths in the biological filter at the beginning of column operation.

The batch reactor operation continued until the column operation was stopped, because the culture from this reactor was used as a seed for the BDOC measurement which was explained in detail in Section 5.3.

5.4.2. Choosing the Most Suitable GAC Type for Biofilters

Batch adsorption / desorption isotherm experiments (reported in Section 5.2) served as a basis for choosing the right GAC type to be employed in continuous-flow biofiltration experiments.

Thermally activated Norit 1240 and Row Supra were the two most efficient GAC types in terms of adsorption characteristics. It was concluded in Section 5.2 that, either of these two carbon grades could be used in continuous-flow experiments if the aim is to adsorb NOM from water. Norit 1240 was selected for this purpose. This way, the efficiency of combined biodegradation–adsorption is expected to be higher than for biodegradation or adsorption alone.

It was also demonstrated in the same section that chemically activated CAgran had inferior adsorption compared to thermally activated carbons in all water samples. On the other hand, its desorbability was better among the GACs tested. Desorption is a very important phenomenon in terms of bioregeneration. In their studies Walker and Weatherley (1997) stated that bioregeneration can only occur with compounds that readily desorb.

Hence, bioregeneration is controlled by the reversibility of adsorption (Schultz and Keinath, 1984; Jonge et al., 1996). Because of its better desorbability, CAgran was also selected for continuous-flow biofiltration experiments. It is not the scope of this study to work on bioregeneration in the BAC columns since continuous flow operation is not suitable for its quantification. The aim is rather to clarify the effect of carbon type on enhancement of biodegradation. For this purpose, two of the four types that were tested in the batch adsorption and desorption experiments were selected. The first chosen GAC grade has the best adsorption properties, Norit 1240, and the latter has the best desorption properties, CAgran.

5.4.3. Continuous-Flow Column Operations

In drinking water biofiltration the filter media supplies surface area for cell attachment and different filter media have different accessible area. For example, the surface of the sand is smooth and non-porous, while the GAC shows a much rougher surface with widely distributed crevasses and ridges. The rougher surface of GAC has been shown to enhance bacterial attachment compared with smoother surfaces (Hattori, 1988). Moreover, the amorphous GAC structures could help protect newly attached bacteria from shear forces, which could have been a major hindrance for biofilm development. Therefore, it is thought that BAC filters should perform better than sand or anthracite filters in terms of biological NOM removal. In the last years, several investigations in parallel compared the efficiency of adsorptive media (GAC) and non-adsorptive media (anthracite and sand) for biological DOC removal. For example, Liu et al (2001) found that GAC filters enhanced the removal of less readily biodegradable substances (glyoxal) in comparison to anthracite filters, especially under unfavorable conditions (e.g., low temperature, Cl_2 in backwash water etc.). Urfer et al. (1997) reviewed different studies and concluded that anthracite/sand and GAC/sand filters provide similar average BOM removals. On the other hand, there is limited information on the effect of GAC type on biodegradation performance. Therefore, it is the purpose of this section to clarify the effect of the GACs (steam activated or chemically activated) on DOC removal. Also, the effect of ozonation on DOC removal was evaluated.

5.4.3.1. Comparison of DOC Removal in GAC and BAC Columns. Adsorption and biodegradation mechanisms are known to be the predominant mechanisms contributing to DOC removal in BAC columns. However, it is difficult to identify the relative importance of the two mechanisms at different operational stages of biofilters. Among the two removal mechanisms, only the removal by individual adsorption can be determined. Therefore, the performances of CAgan and Norit 1240 columns were examined in a system in which only adsorption occurs. The comparison was only made with raw water. In order to assure that no biodegradation took place in the system, the influent raw water was autoclaved. Therefore, the GAC column was expected to adsorb only. On the other hand, in the BAC column, both adsorption and biodegradation mechanisms would be seen for DOC removal before the breakthrough. After breakthrough is reached, DOC removal can only occur by biodegradation. The comparison of DOC removal performances of sterile GAC and BAC columns was presented in Figure 5.32.

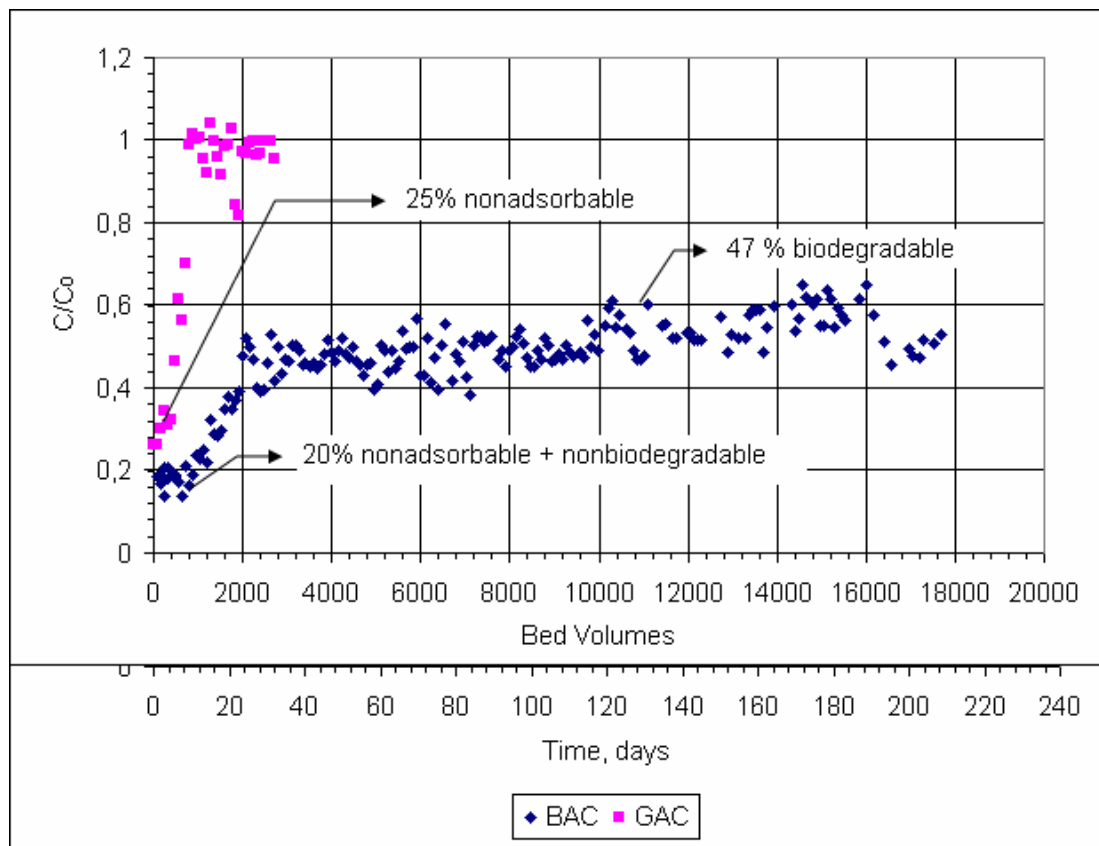


Figure 5.32 Normalized DOC in the effluent of sterile GAC and BAC of CAgan

The influent and effluent DOC concentrations are reported as a function of the number of bed volumes instead of the volume treated or the time of treatment. The number of bed volumes is a particularly useful parameter because data from columns of different sizes and with different flow rates are normalized. With the present working conditions, one bed volume equals to approximately 160 mL. In other words, 1000 bed volumes are equal to 12.5 days of operation.

Examination of Figure 5.32 shows that after approximately 1000 bed volumes, complete breakthrough of DOC was observed in the sterile GAC column. Until breakthrough was reached, it was found that 25% of total DOC was nonadsorbable. The column was continued for a further 1200 bed volumes, during which time no DOC removals were detected in the effluent of the GAC column. On the other hand, in the BAC column, breakthrough commenced at later times. In addition to this, the effluent DOC concentrations in the initial stages of the operation from this column (BAC) were shown to be less than that of the sterile GAC column, indicating the presence of active bacteria effectively removing DOC. The effluent of BAC column before breakthrough quantifies both nonadsorbable and nonbiodegradable matter. Therefore, the nonadsorbable + nonbiodegradable fraction composed 20% of total DOC. At later stages, the presence of bacteria resulted in 47% removal of DOC.

The same comparison was done also for Norit 1240 in the case the raw water and the results were depicted in Figure 5.33.

Breakthrough commenced at approximately after 4000 bed volumes for the sterile Norit 1240. 22% of the DOC was found to be nonadsorbable. Compared to the results of sterile CAgan, Norit 1240 outperformed in terms of NOM adsorption, which was also shown in batch adsorption isotherm experiments (Section 5.2). For the BAC column, breakthrough did not start at all during the 220 days of column operation. It is very clear from Figure 5.33 that biodegradation extended the operation life time of Norit 1240. It is assumed that biological activity enhanced the adsorption capacity of GAC for nonbiodegradable compounds by eliminating substances that would otherwise compete for adsorption sites. The nonadsorbable + nonbiodegradable fraction leaving the Norit 1240 was 20% of the total DOC.

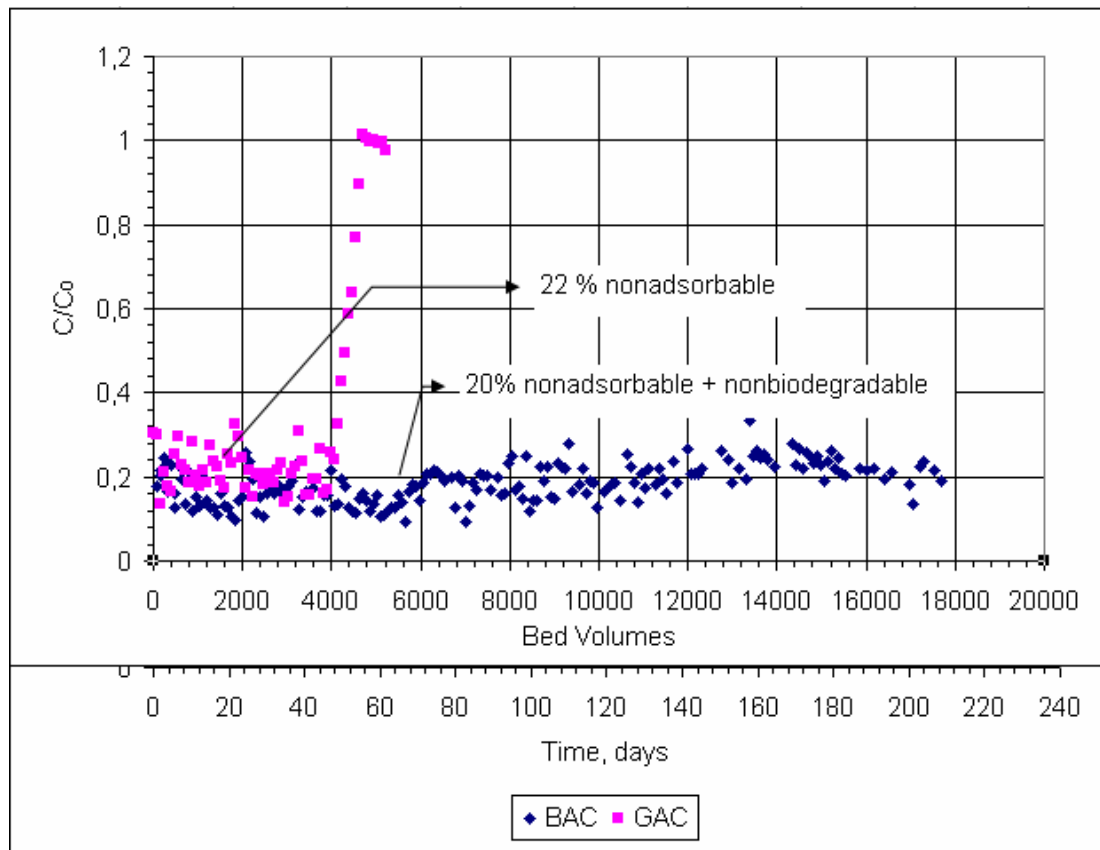


Figure 5.33 Normalized DOC in the effluent of sterile GAC and BAC of Norit1240

The sterile GAC columns were also analyzed for influent and effluent $\text{NH}_4^+\text{-N}$ and $\text{NO}_3^-\text{-N}$ concentrations. The results were presented in Figures 5.34 and 5.35.

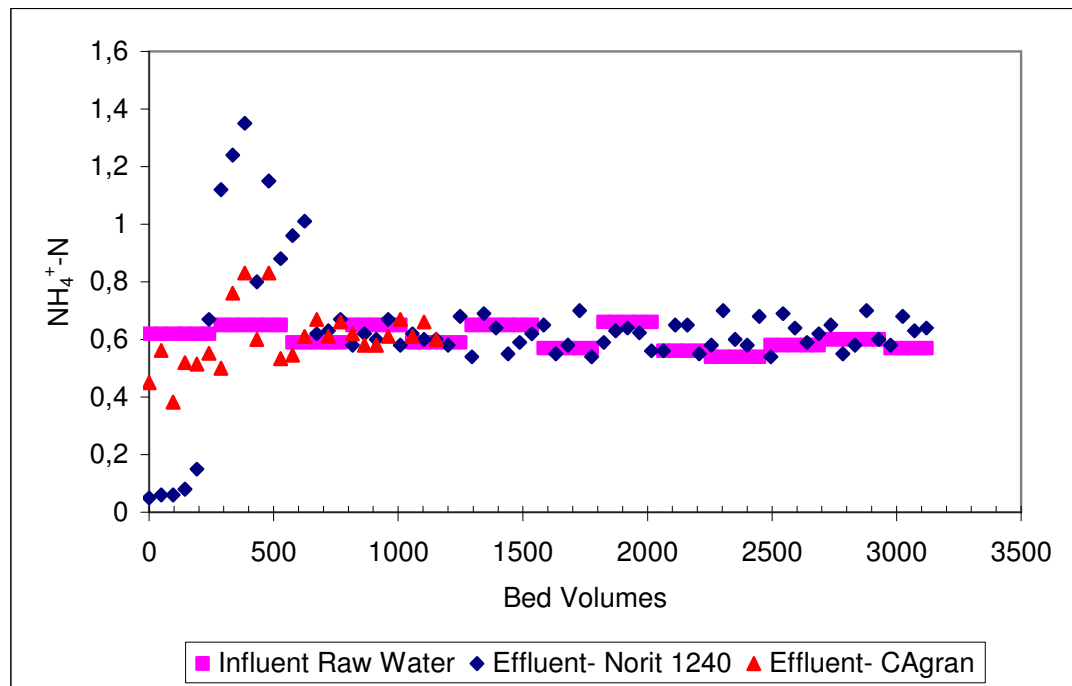


Figure 5.34 Influent and effluent $\text{NH}_4^+\text{-N}$ concentrations in sterile GAC columns

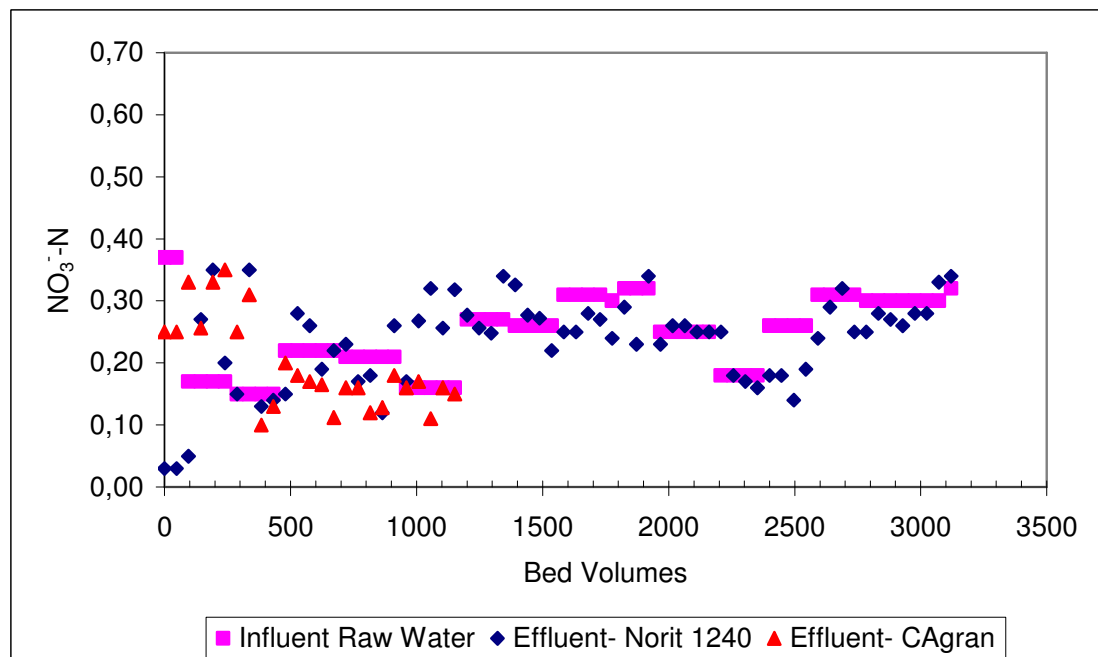


Figure 5.35 Influent and effluent $\text{NO}_3^-\text{-N}$ concentrations in sterile GAC columns

Ammonium ion was found to reversibly sorbed onto the Norit 1240 during the first 200 bed volumes. For the next 400 bed volumes, all of the previously sorbed NH_4^+ -N was desorbed into the bulk liquid. Afterwards, the influent and effluent concentrations were the same. Similarly, NO_3^- -N was sorbed onto the Norit 1240 at the first days of the operation, then, NO_3^- -N passed the columns with the same concentrations as the influent. Sorption of NH_4^+ -N and NO_3^- -N were not observed for CAgran due probably due to its open structure.

5.4.3.2. Sampling from the Ports of Sterile GAC Columns. During the operation of sterile GAC columns, water samples were taken from the ports located at the 0, 27 and 52 cm above the bottom. Height of the packed GAC column is 50 cm, therefore, the top port is 2 cm above the GAC media. Samples were analyzed for DOC, NH_4^+ -N and dissolved oxygen concentrations.

Figure 5.36 shows the port measurements done at bed volumes of 600, 2400 and 5000. At a bed volume of 600, adsorption sites on the sterile GAC were mostly empty. Breakthrough was experienced at a bed volume of 2400. Port experiments done at a bed volume of 5000 represent the situation when the adsorption capacity of the column has already been exhausted. Oxygen concentrations along the column depth decreased at all stages of column operation. Through the 50 cm of carbon depth, approximately 90 % of the oxygen was lost in the bulk liquid. This is due to the chemisorption of oxygen onto GAC pores. Thermally activated carbons have high affinities towards oxygen and upon contact with oxygen, surface chemistry of GAC may change (Jonge et al., 1996). Since thermal activation of these carbons is carried out in the absence of oxygen, they have a more reactive surface. Contrary to this, chemically activated carbons have a surface with fully oxidized active sites so that interaction with oxygen does not affect the surface. Sampling from the ports of the sterile CAgran revealed limited oxygen uptake (not more than 3.5% decrease) along the depth of the column (Figure 5.37).

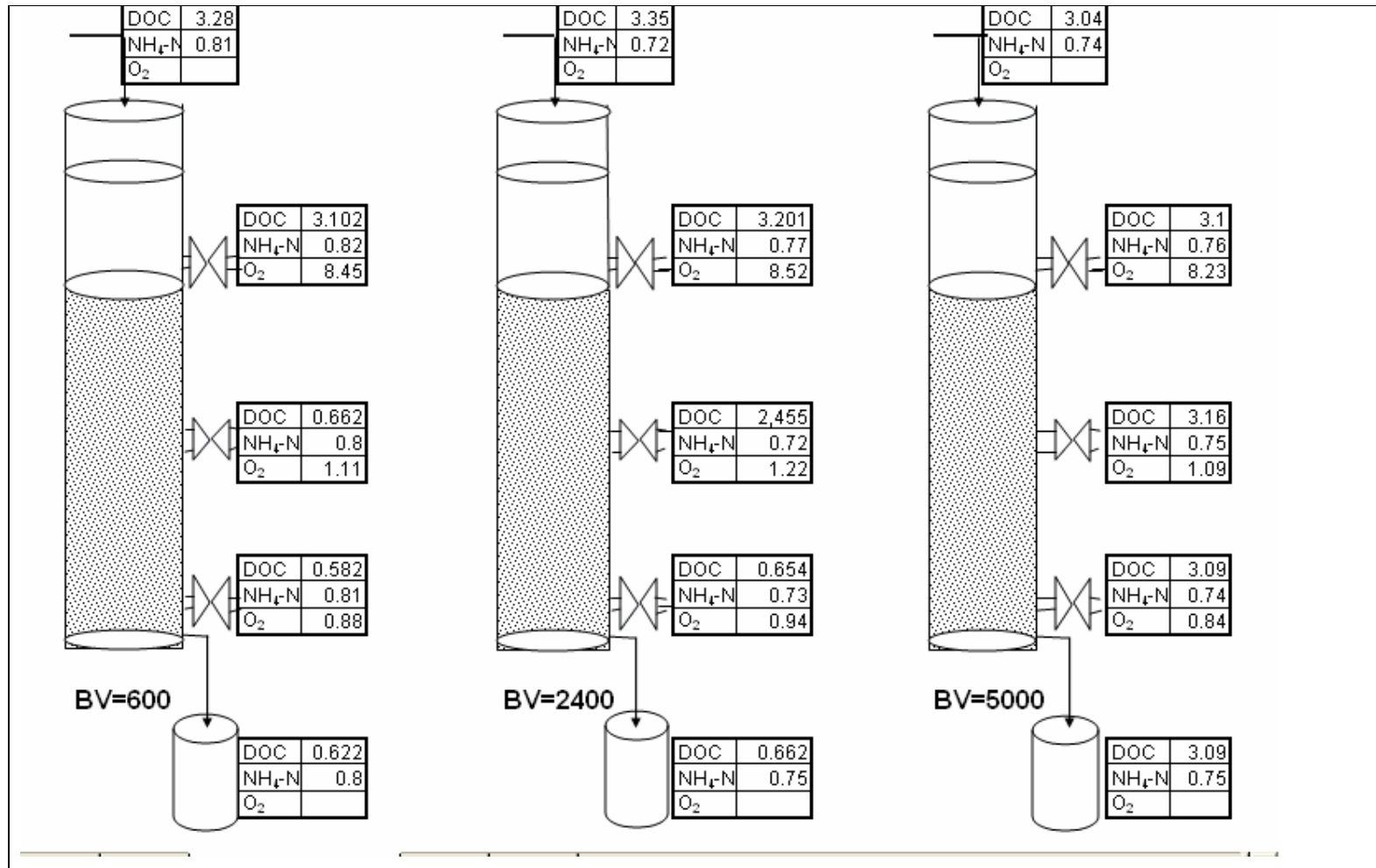


Figure 5.36 Concentrations along the length of the sterile Norit 1240 column fed with raw water

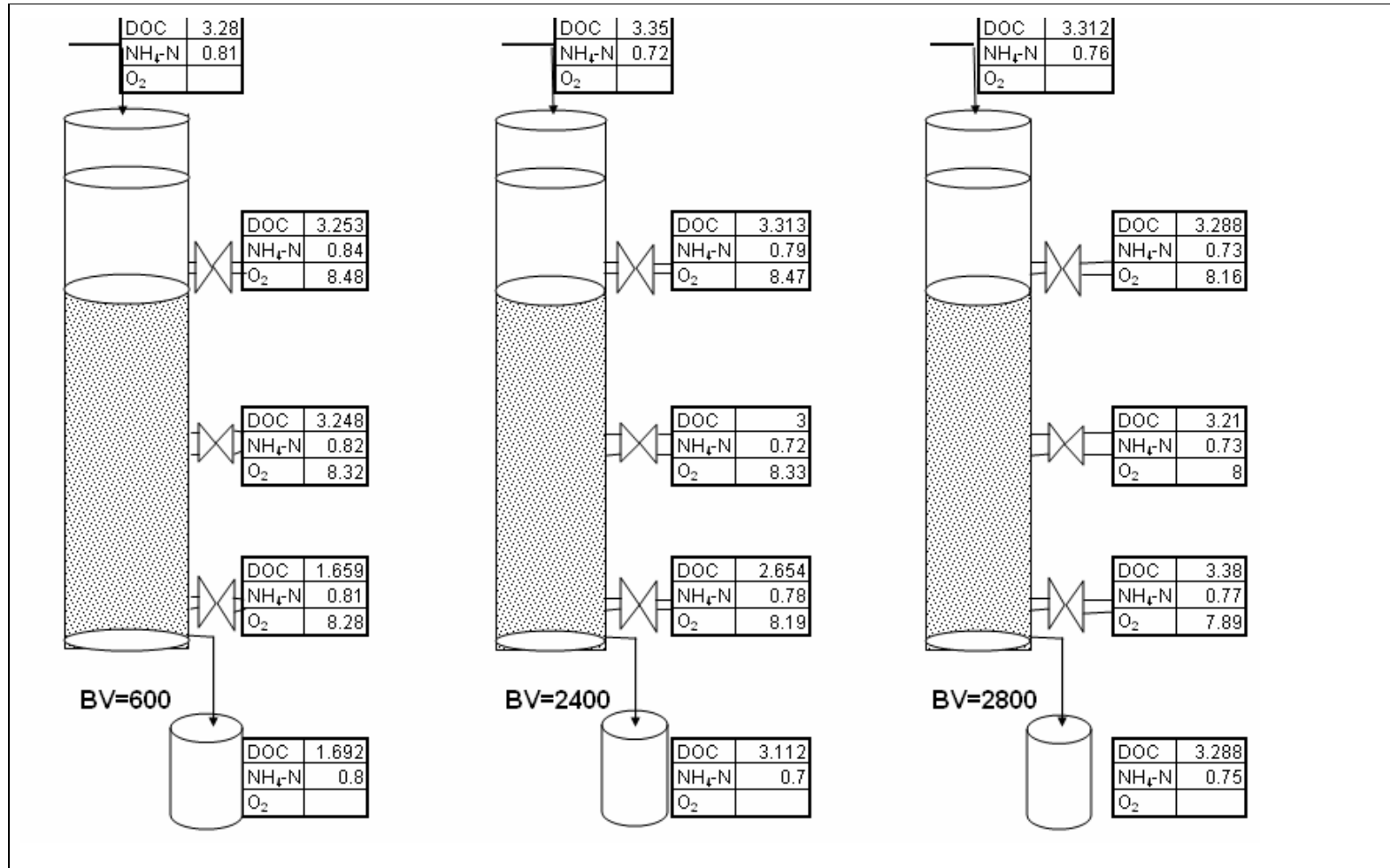


Figure 5.37 Concentrations along the length of the sterile CAgran column fed with raw water

5.4.3.3. BAC Columns. Continuous-flow biofilters were operated for more than 220 days before shutdown. Although there is a change in DOC in the feed water, due to the variation in water quality, the trends are very clear. There is a decreasing trend in influent DOC. This is related to seasonal changes in DOC. In winter months, DOC in the reservoir always decreases due to dilution by rain and snow. In addition to this, lately, a small fraction of the Melen Creek water was connected to the reservoir. This may also have an effect on this decrease.

DOC removal in the BAC filters with respect to bed volumes treated is shown in Figure 5.38.

As discussed in detail in Section 5.1.4, an ozone dose of 2 mgO₃/mg DOC was used for ozonation of the water. This way, maximum biodegradability of the influent was achieved. The influent ozonated water DOC concentrations were not significantly different ($p=0.64$) from those of raw water influents, as determined using ANOVA and according to 95% confidence interval. This means that mineralization of DOC during ozonation was avoided. Indeed, the percent DOC decrease upon ozonation was less than 5% in all cases.

5.4.3.4. Operation of CAgran. The fastest breakthrough of DOC was observed with CAgran. The exhaustion was seen over approximately 2000 bed volumes for both raw and ozonated water. Exhaustion of the column took place approximately at the same time for both raw water and ozonated water. Therefore, ozonation did not seem to have any effect on adsorption of NOM during continuous-flow operation. However, in batch adsorption experiments, which were explained in detail in Section 5.2.5.3, for CAgran, adsorption became more unfavorable, compared to raw water when water was ozonated. In practice, the results of batch and column tests may depict different characteristics of the carbon. Results obtained from batch tests represent the maximum uptake for a given carbon at a given NOM concentration. In contrast, column tests depict the adsorption of NOM from the solution passing through the carbon. In the current study, as previously stated, biodegradation and adsorption occur simultaneously in columns. Biodegradation may have offset the unfavorable effect of ozonation. Ozonation usually causes a shift in molecular size distribution to lower values. Therefore, in batch adsorption experiments CAgran could not adsorb lower molecular weight organics due to its macroporous structure.

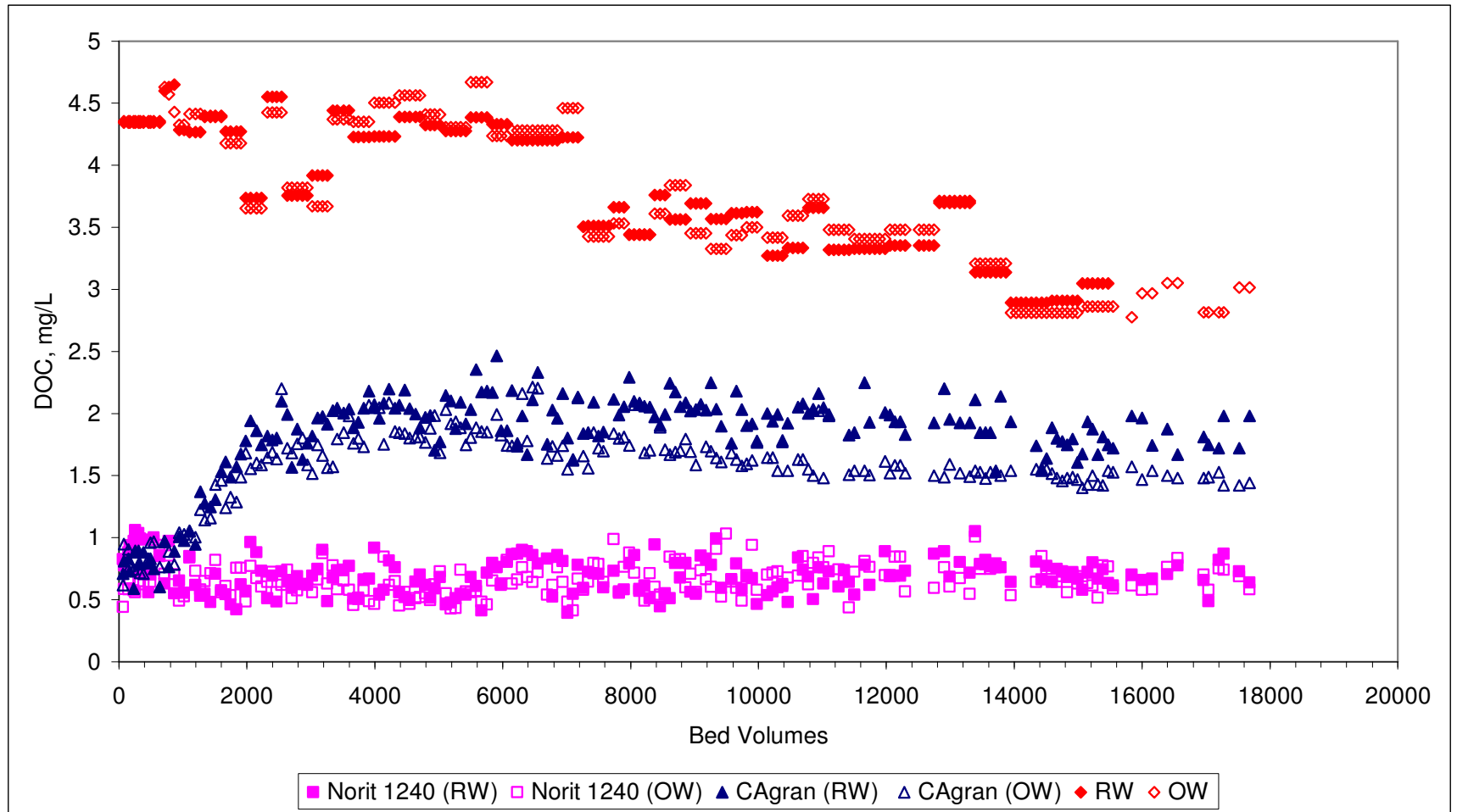


Figure 5.38 Influent and effluent DOC concentrations in the two continuous-flow BAC columns (CAgran and Norit 1240) tested with raw and ozonated water (RW: Raw Water; OW: Ozonated Water)

When these low molecular weight substances are biodegraded, the effluent DOC concentration in the column was lower. Furthermore, the nonadsorbable DOC of the CAgran in batch experiments was 1.1 mg/L and 1.7 mg/L for raw water and ozonated water, respectively. On the other hand, in CAgran columns, before the breakthrough, the effluent DOC concentration was 0.6 mg/L for both raw and ozonated water. This difference can also be attributed to biodegradation. The effluent DOC from the batch experiments contained biodegradable fraction and some of this fraction was biodegraded in the columns. Hence, column effluents represent both the nonadsorbable and nonbiodegradable DOC.

Before the exhaustion of CAgran, both adsorption and biodegradation simultaneously took place on the surface since filters were biologically active from the first day of the operation. On the other hand, after exhaustion of filter capacity, biodegradation was the dominant mechanism. Therefore, as is clear in Figure 5.38, the difference between the influent and the effluent DOC concentrations after exhaustion can be attributed to mostly biodegradation. In this case, the average DOC removal by biodegradation is 47% for the raw water, and 53% for the ozonated water. When the influent raw water DOC was 3.65 mg/L, an effluent DOC concentration of 1.94 mg/L was generally achieved (Table 5.7). This means that 1.71 mg/L of DOC was biodegraded in the system fed with raw water. Surprisingly, the average BDOC concentration in the influent was not as high this value. The influent and effluent BDOC values for raw and ozonated water were depicted in Figures 5.39 and 5.40, respectively. For the ozonated water, influent DOC was lowered from an average value of 3.56 mg/L to 1.62 mg/L by biodegradation, which corresponds to a removal of 1.94 mg/L. The average influent BDOC for the ozonated water was 1.76 mg/L. This means that, biological DOC removal in the column fed with ozonated water is slightly higher than the influent biodegradable DOC (BDOC). As explained earlier, BDOC measurement is done using a suspended culture with limited bacteria concentration and poor mixing conditions. It is therefore assumed in general that the actual BDOC concentration is underestimated when doing the test. Previously, it was shown in Section 5.4.1 that the batch suspended culture grown as a seed for BAC columns could biodegrade up to 40% of initial DOC. The amount of biodegradation in the reactor was also higher than that of influent biodegradable organic carbon (e.g., average biodegradable carbon as BDOC: 1.2 mg/L; average biodegradation: 1.5 mg/L). Therefore, observing more

biodegradation than the available biodegradable carbon should not be attributed to adsorption. Moreover, BAC columns are attached growth systems. Attached growth systems are always more efficient than suspended growth systems in contaminant removal. In addition to this, GAC provides a long retention by adsorption which increases the chance for the slowly biodegradable substances to be degraded in the columns.

Table 5.7 Comparison of average DOC biodegradation with influent biodegradable DOC (BDOC) concentration

	Influent DOC, mg/L	Effluent DOC, mg/L	DOC removed, mg/L	Influent BDOC
CAgran fed with Raw Water	3.65	1.94	1.71	0.68
CAgran fed with Ozonated Water	3.56	1.62	1.94	1.76
Suspended Culture Batch Reactor	3.50	2.00	1.50	1.20

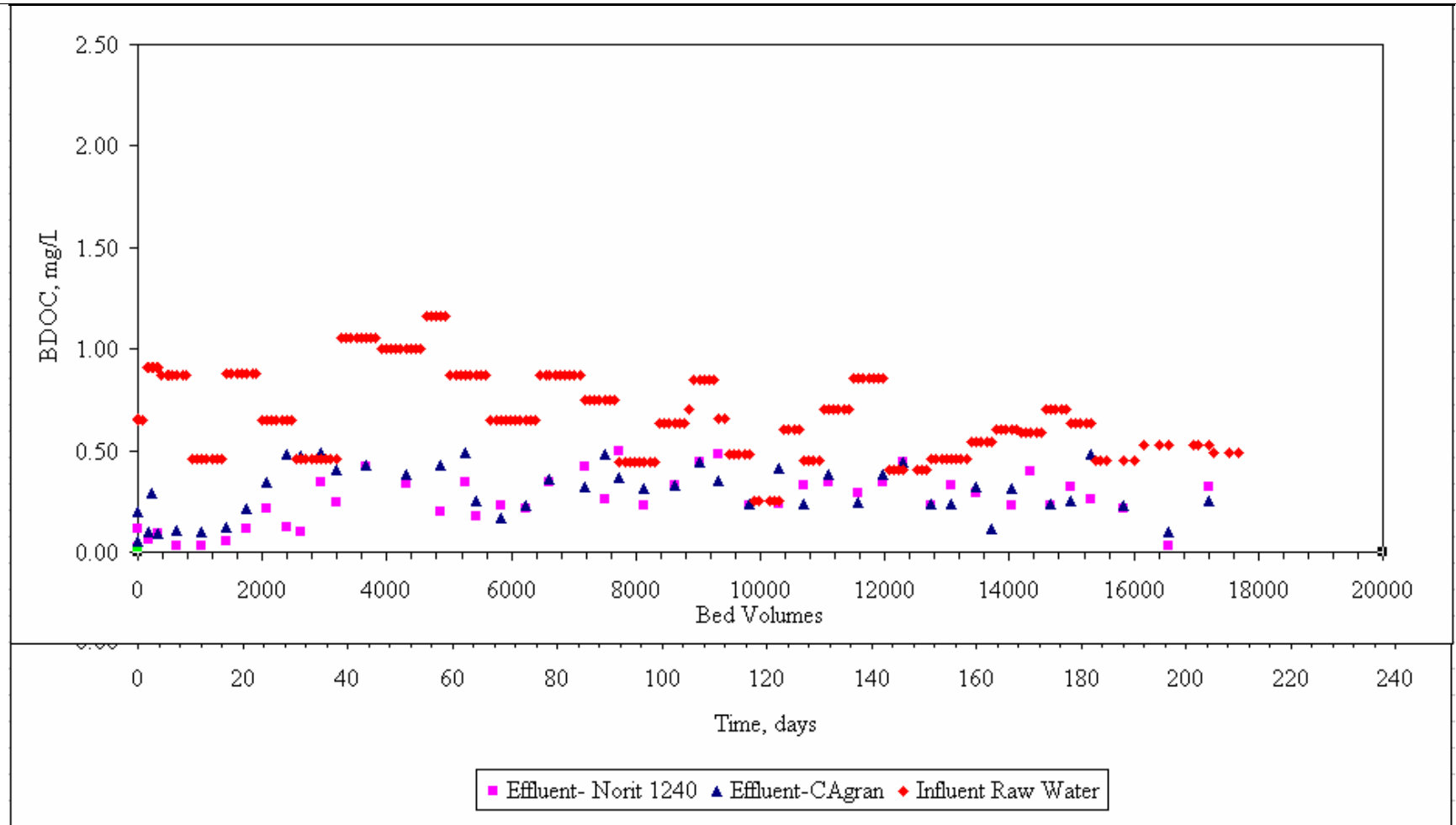


Figure 5.39 Influent and effluent BDOC values of the continuous-flow BAC columns tested with raw water (RW: Raw Water)

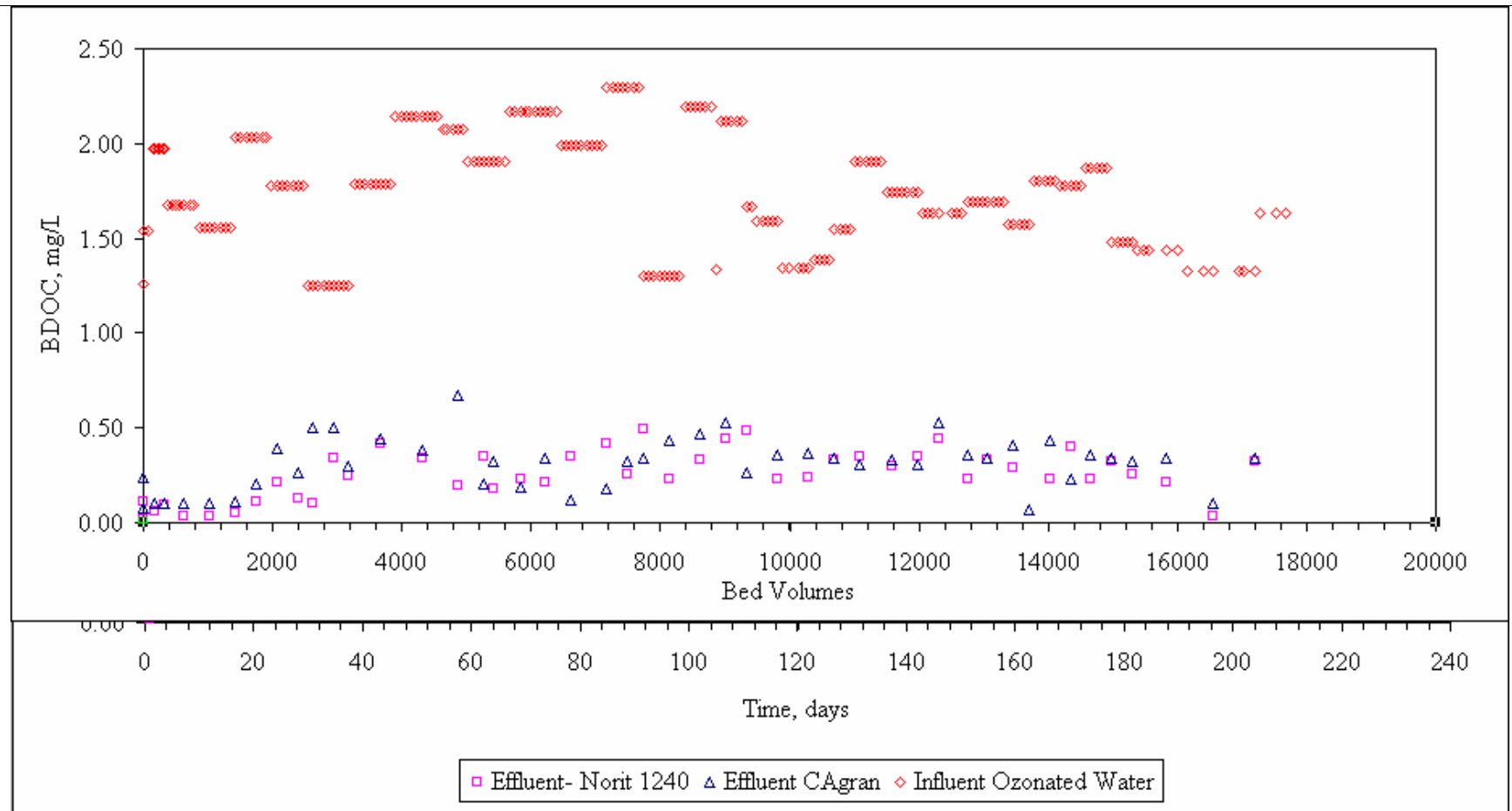


Figure 5.40 Influent and effluent BDOC values of the continuous-flow BAC columns tested with ozonated water

Figure 5.39 and 5.40 suggest that, CAgran and Norit 1240 gave similar effluent concentrations of BDOC both for raw water and ozonated water. The average effluent BDOC values of CAgran and Norit 1240 for the raw water were 0.29 mg/L and 0.24 mg/L, respectively. Therefore, based on the average influent raw water BDOC concentration, 57% and 64% of the BDOC was removed in the BAC columns for CAgran and Norit 1240, respectively. For the ozonated water, average effluent BDOC concentrations of 0.31 mg/L for CAgran and 0.23 mg/L for Norit 1240 were observed. The average BDOC removals of 83% and 87% were observed for CAgran and Norit 1240, respectively. The effluent BDOC concentration remained approximately constant and was not affected from the changes in influent BDOC. The effluent BDOC concentrations are important in terms of biofilm growth potential in the distribution network. An absence of biodegradable organics after water treatment to limit bacterial regrowth has been recommended in the literature (Block et al., 1993). Servais et al. (1993) have associated biological stability, which corresponds to no BDOC consumption within the distribution system, with a BDOC concentration of 0.16 mg/L or less in the finished water in the absence of disinfectant. In this case, the effluent BDOC concentrations are higher than the indicated limit for the biostability. On the other hand, according to Escobar and Randall (2001), BDOC by itself gives an over-estimation of the improvement in regrowth potential and AOC and BDOC provide complementary information and it is advisable, not redundant, to measure both. Therefore, AOC measurement is also required to determine the biostability level of effluent water.

Column experiments were done in order to examine the DOC, $\text{NH}_4^+\text{-N}$, and dissolved oxygen profiles of the ports that were located at different column depths. The results of the column experiments were summarized in Figure 5.41 and Figure 5.42.

Influent $\text{NH}_4^+\text{-N}$ concentrations decreased both in the raw and ozonated water as soon as water sample entered the column. At least a height of 10 cm of free was provided above the packing media and the uppermost sampling port was located 2 cm above the GAC media. The immediate decrease in concentration was probably due to dilution and biodegradation.

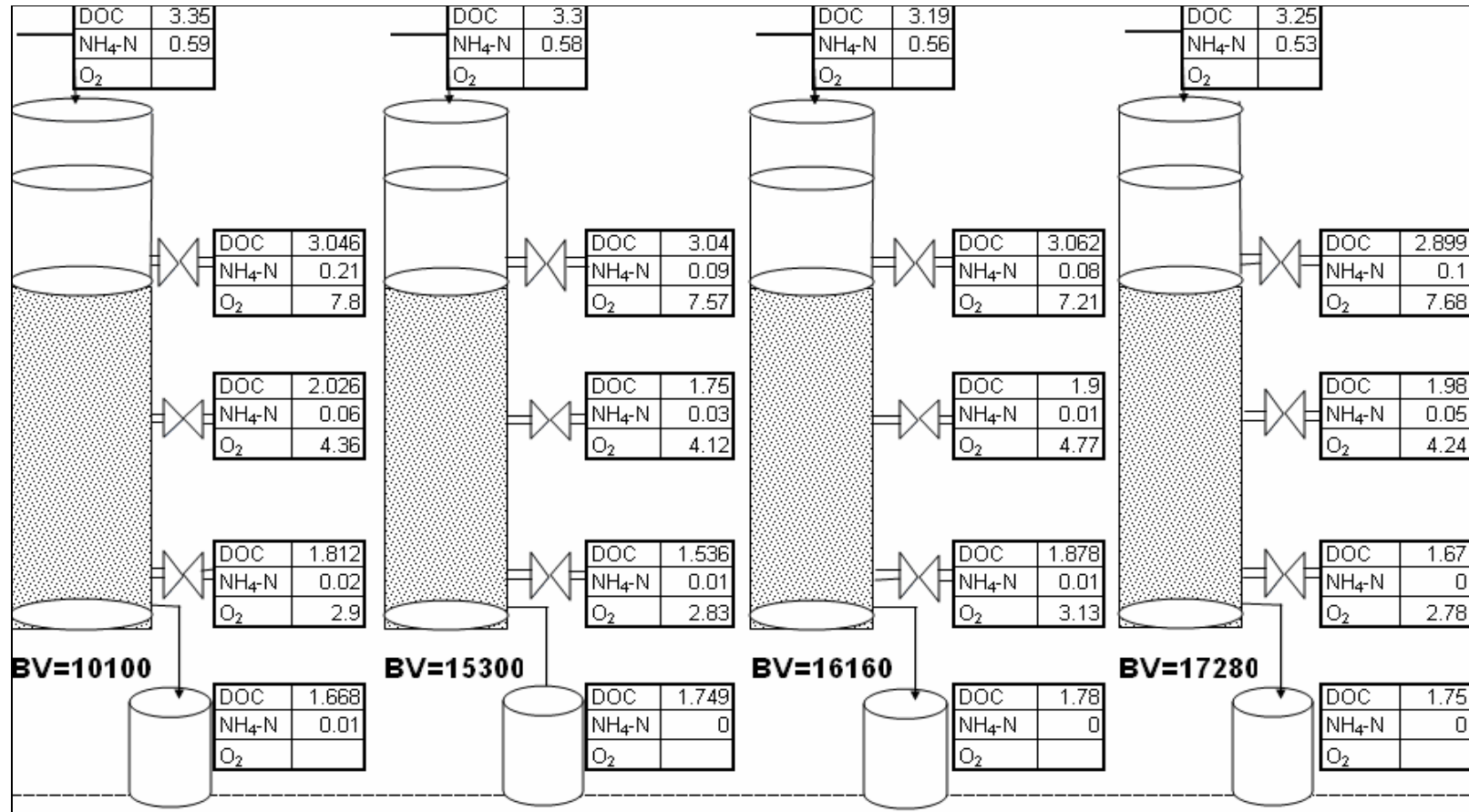


Figure 5.41 Concentrations along the length of the CAgran fed with raw water at different bed volumes (10000 BV corresponds to 125 days after start-up)

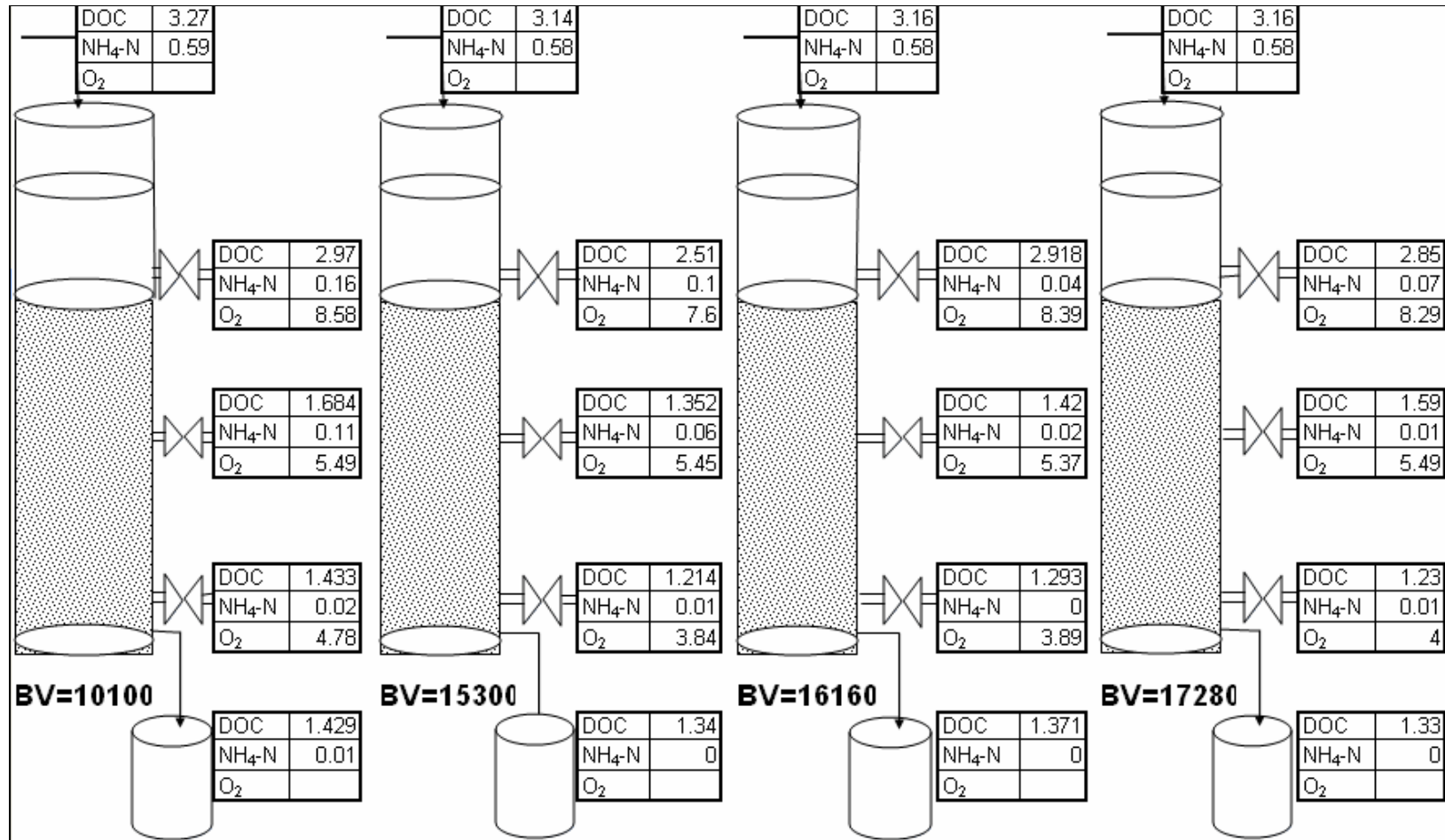


Figure 5.42 Concentrations along the length of the CAggran fed with raw water at different bed volumes (10000 BV corresponds to 125 days after start-up)

On average, 42% of the DOC was biodegraded in the first 25 cm of the column and a further 5% biodegradation was seen in the lower part of the column fed with raw water. Therefore, the first 25 cm of the column (equivalent to an EBCT of 9 min) were responsible for most of the biodegradation. It is expected that a biomass gradient was present with the maximum biomass fixed in the first centimeters of the filters explaining that most of the DOC removal occurred during the 9 min EBCT. Results obtained from the study of Hozalski et al. (1995) also showed similar results. The mean TOC removals in biofilters consisting of sand operated at EBCTs of 4, 10, and 20 minutes indicated that mean removals were not significantly different at the 5% significance level. This is an expected result when one considers that BOM removal in the biofilters is roughly proportional to existing biomass. This result is supported by some studies (Servais et al., 1992; Wang et al., 1995; Miltner et al., 1995)

Previously, it was shown that CAgran chemisorbed a limited amount of dissolved oxygen on its surface. It was found that 3.5% of the initial dissolved oxygen was lost in a carbon depth of 0.5 m. Therefore, further decrease in oxygen concentration through the depth can be considered as the oxygen uptake due to carbon biodegradation and nitrification. In nitrification, about $4.57 \text{ mgO}_2/\text{mgNH}_4^+\text{-N}$ is consumed by nitrifiers in stoichiometric proportions (Metcalf and Eddy, 2003). For carbon biodegradation an average value of 1mg DO /1mg COD can be taken. Also, the organic carbon concentration can be converted into oxygen demand using a conversion factor of 2.66. The dissolved oxygen balance is presented in Table 5.7. In the calculations, the oxygen requirement due to nitrite oxidation was neglected because of its negligible concentration. A similar comparison was also done in a study conducted by Yu et al. (2007), the purpose of which was to explain the nitrogen loss and oxygen paradox in a full scale treatment plant.

Table 5.8 compares the oxygen uptake resulting from carbon biodegradation and nitrification with the measured oxygen uptake along the column depth (Columns (6) and (7)). Results showed that the theoretical oxygen consumption and the measured dissolved oxygen values were in good agreement with each other.

Table 5.8 Examples of the calculation of the theoretical and actual oxygen consumptions

Sample	ΔDOC	$\Delta\text{DO}_{\text{COD}}$	$\Delta\text{NH}_4^+\text{-N}$	$\Delta\text{DO}_{\text{NH}_4^+\text{-N}}$	$\Delta\text{DO}_{\text{cs}}$	$\Delta\text{DO}_{\text{th}}$	$\Delta\text{DO}_{\text{actual}}$
	(1)	(2)	(3)	(4)	(5)	(6)	(7)
Raw Water BV=10100	1.234	3.282	0.23	1.05	0.273	4.607	4.9
Raw Water BV=15300	1.504	4.001	0.08	0.366	0.265	4.631	4.74
Raw Water BV=16160	1.180	3.139	0.07	0.320	0.252	3.711	4.08
Raw Water BV=17280	1.229	3.269	0.10	0.457	0.273	3.999	3.90
Ozonated BV=10100	1.537	4.088	0.14	0.640	0.300	5.029	4.9
Ozonated BV=15300	1.296	3.447	0.09	0.411	0.265	4.631	4.74
Ozonated BV=16160	1.630	4.336	0.04	0.183	0.294	4.812	4.5
Ozonated BV=17280	1.620	4.309	0.07	0.320	0.290	4.919	4.29

(1) ΔDOC : Measured DOC removal (mg C/L)

(2) $\Delta\text{DO}_{\text{COD}}$: Calculated DO consumption in terms of COD removed ($2.66 \times 1\text{mg DO}/1\text{mg COD} \times \Delta\text{DOC}$)

(3) $\Delta\text{NH}_4^+\text{-N}$: Measured $\text{NH}_4^+\text{-N}$ removal

(4) $\Delta\text{DO}_{\text{NH}_4^+\text{-N}}$: Calculated DO consumption for $\text{NH}_4^+\text{-N}$ ($4.57 \text{mgO}_2/\text{mgNH}_4^+\text{-N} \times \Delta\text{NH}_4^+\text{-N}$)

(5) $\Delta\text{DO}_{\text{cs}}$: Determined DO consumption due to chemisorption (assumed as $3.5\% \times \text{Initial DO}$)

(6) $\Delta\text{DO}_{\text{th}}$: Theoretical DO consumption ($\Delta\text{DO}_{\text{COD}} + \Delta\text{DO}_{\text{NH}_4^+\text{-N}} + \Delta\text{DO}_{\text{cs}}$)

(7) $\Delta\text{DO}_{\text{actual}}$: Initial DO – Final DO

It is well established that ozonation can increase the biodegradable portion of DOC. Studies up to now showed that, increase in the biodegradable DOC results in enhanced biological DOC removal. The percent increase in BDOC upon ozonation at a dose of 2 mgO₃/mg DOC was observed as high as 245%, whereas the average increase was 166%. Despite this huge increase, the biological DOC removal efficiency was not so much affected when ozonated water used in the influent. The biological DOC removal was only 8% higher with respect to the removal in the raw water. Therefore, ozonation did not have a pronounced effect on DOC removal. It is assumed that the dominant mechanism of DOC removal for the current filters is biodegradation. This was accepted because the CAgran reached breakthrough beforehand. Also, it was observed that biodegradation is coupled with a decrease in dissolved oxygen consumption which was shown by port sampling. The amount of DOC removed in the system just corresponded to the oxygen consumption in the filter. The most logical explanation is that, Ömerli water was composed mainly of slowly biodegradable organic carbon, and most of the organic carbon can be biodegraded on BAC surface. The DOC in raw water can attach to the biofilm for a long time, so that the chance of biodegradation is increased. As explained in Section 5.4.1, the inoculated bacteria were well acclimated to Ömerli water and it was assumed that they produced specific enzymes to treat even the hardly biodegradable organics of the reservoir. It is for sure that ozonation made them readily biodegradable, but the contribution of ozonation is marginal in these columns.

From Figure 5.39 and 5.40, it is seen that the influent BDOC concentration both in the raw and ozonated water decreased. At the same time, these decreases are coupled with the decrease in influent DOC. The percent biodegradability, expressed as BDOC/DOC was shown in Figure 5.43. Figure 5.43 shows that the percentage of influent BDOC found in DOC remained constant in all water samples which were examined for 240 days. 18% of the DOC was biodegradable in raw water samples. Joret et al. (1991) suggested that BDOC values represent 10–30% of the total dissolved organic carbon content of drinking water. Ömerli water also lies within these limits. For the ozonated water, on the other hand, this ratio had an increasing trend. The percent biodegradability increased approximately from 40% to 50% in a period of approximately 220 days.

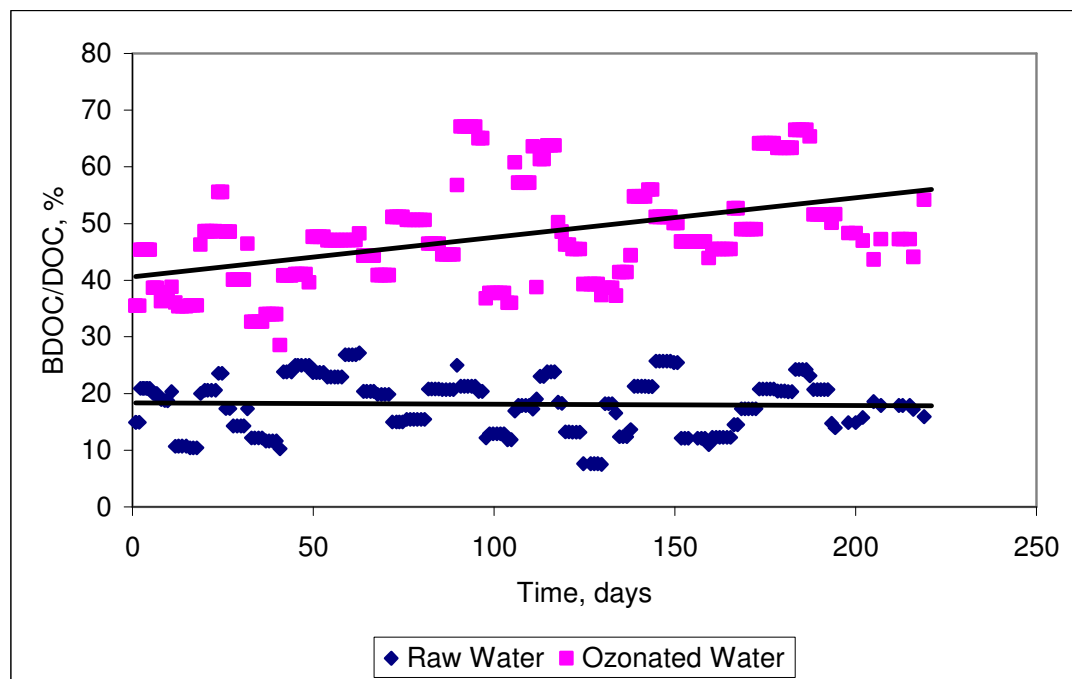


Figure 5.43 Percent biodegradability of raw water and ozonated water

UV_{254} and UV_{280} absorption values are popular as indexes of the aromatic level. The data presented in Figures 5.44 through 5.47 show the influent and effluent UV_{254} and UV_{280} absorption values both for the raw and ozonated water.

The average UV_{254} and UV_{280} values for the raw water were 0.093 cm^{-1} and 0.073 cm^{-1} , respectively. Upon ozonation, even if no DOC mineralization occurred (<5%), around 45% decrease both in the UV_{254} and UV_{280} parameters were seen. Previous studies reported that ozonation reduces UV absorbance by as much as 45% (Kaastrup and Halmo, 1989) and 56% (Owen et al., 1995) at an ozone dosage of about $1 \text{ mgO}_3 / \text{mgDOC}$. This reduction indicates the breakdown of some conjugated carbon structures leading to fragmentation of high molecular weight organic substances into smaller units. Obviously, the reaction between ozone and DOM resulted mainly in structural transformations of organic material with a little loss of organic carbon as indicated by the very low reduction in DOC.

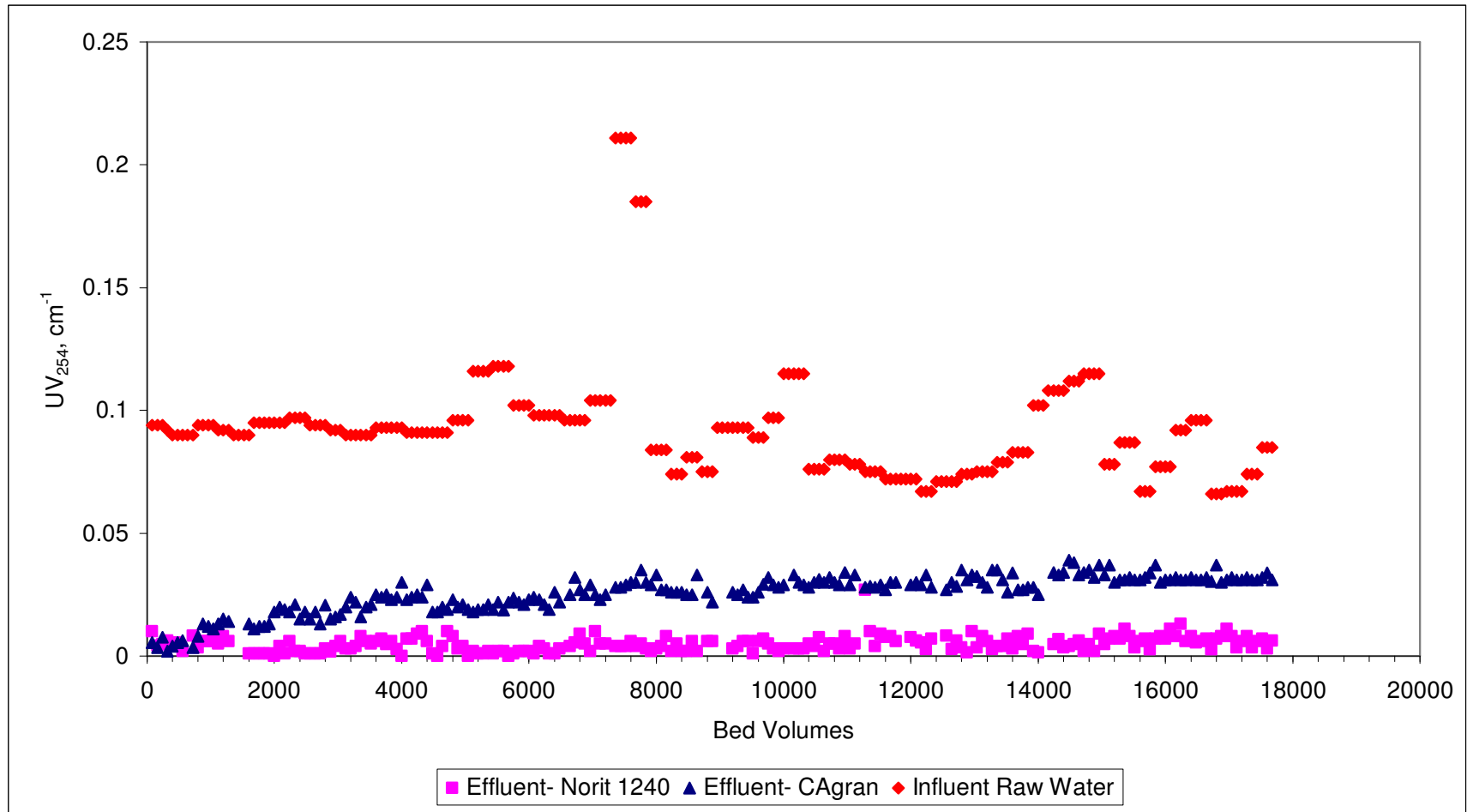


Figure 5.44 Influent and effluent UV₂₅₄ concentrations in continuous-flow BAC columns tested with raw water

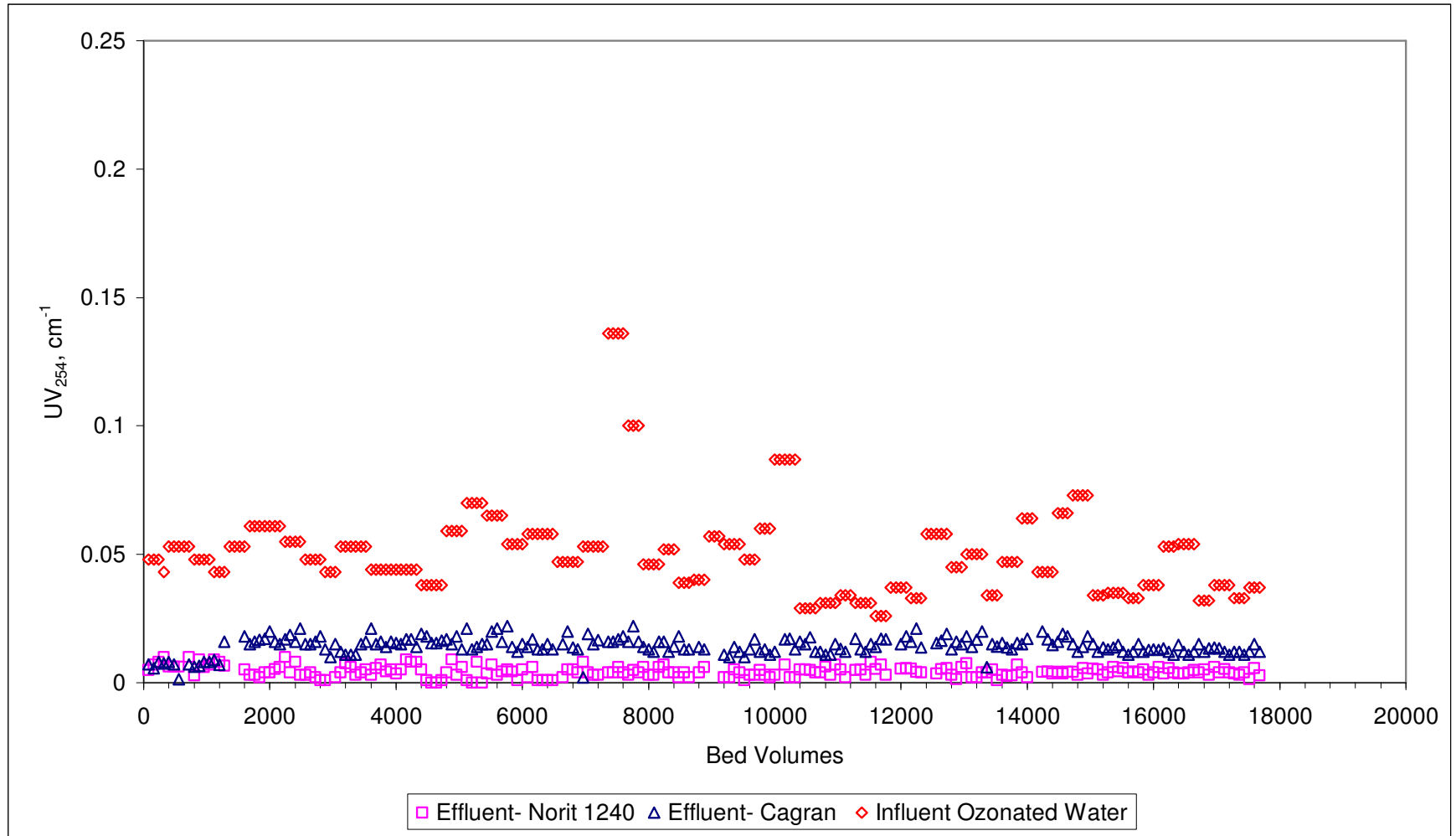


Figure 5.45 Influent and effluent UV₂₅₄ concentrations in continuous-flow BAC columns tested with ozonated water

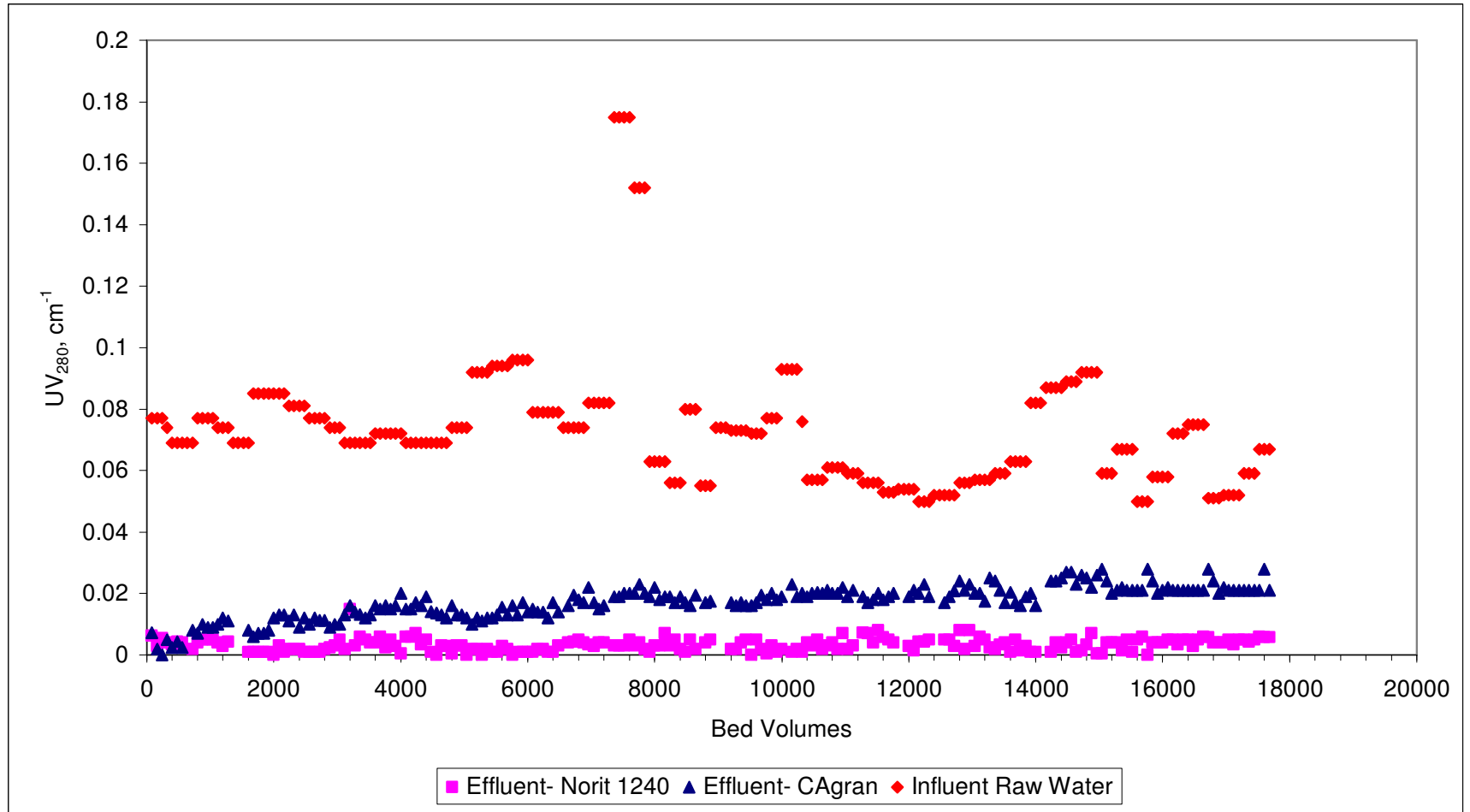


Figure 5.46 Influent and effluent UV₂₈₀ concentrations in continuous-flow BAC columns tested with raw water

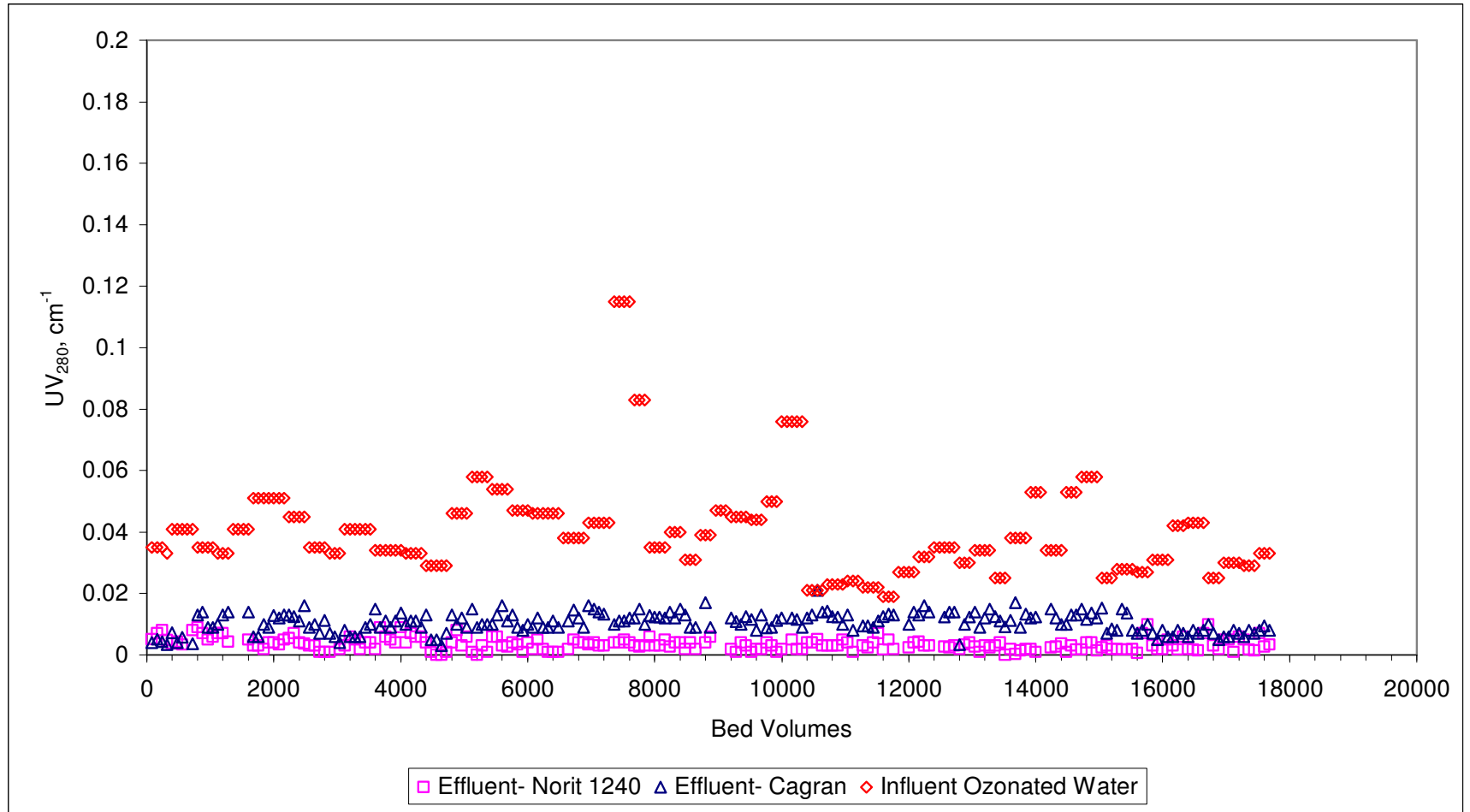


Figure 5.47 Influent and effluent UV₂₈₀ concentrations in continuous-flow BAC columns tested with ozonated water

Calculation of SUVA based on DOC and UV_{254} measurements showed that the average SUVA values of raw and ozonated waters were 2.5 and 1.42 $m^{-1}/(mg\ DOC/L)$, respectively. SUVA values of influent raw and ozonated water were depicted in Figure 5.48.

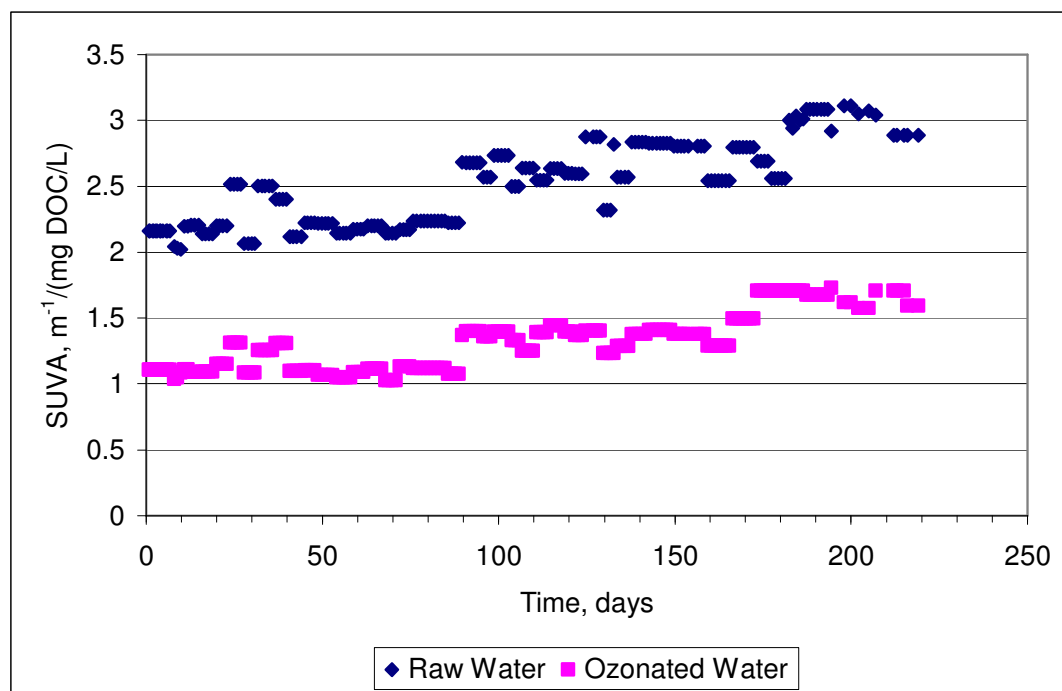


Figure 5.48 Influent SUVA values in raw and ozonated water

Figure 5.48 shows an increasing trend in the SUVA values of raw and ozonated water with respect to time. SUVA values in raw water were as high as 3.3, whereas in ozonated water this values never exceeded 1.7. SUVA provides a quantitative measure of unsaturated bonds and/or aromaticity within NOM. Increase in SUVA generally reflects higher humification, aromaticity and hydrophobicity of DOM and hence, lower biodegradability. According to the classification of Edzwald and Tobiason (1999), a SUVA value of 4 and greater values indicates that water sample consists mainly of humic materials and higher molecular weight substances. When this value is below 2, this means that NOM is mainly non-humic and that hydrophobicity is low. SUVA values between 2 and 4 indicate that, NOM consists of a mixture of aquatic humics and other NOM. The average SUVA value of the raw water was close to 2, therefore, the aromaticity within NOM was not high, and hence a high biodegradability of raw water can be expected.

In order to investigate the role of humification on DOC biodegradation, percent DOC biodegradation was correlated to SUVA. The Pearson's product momentum correlation coefficient (r_p) for the relationship was used for linear estimation of the strength and direction of the correlation. The relationship was depicted in Figure 5.49.

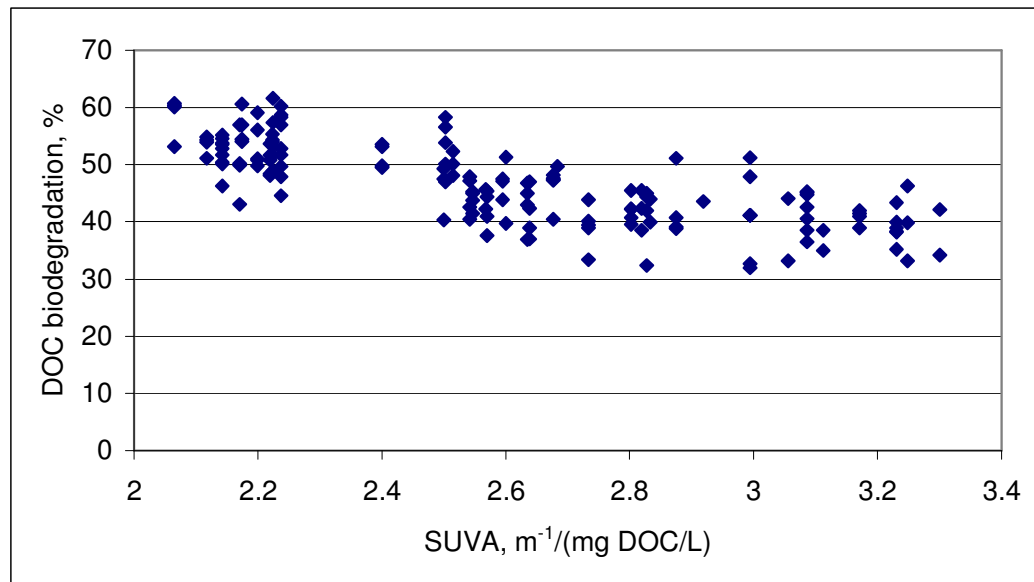


Figure 5.49 Relationship between SUVA and DOC biodegradation in raw water

Indeed, in raw water samples the increase in SUVA value resulted in a decrease in percent DOC biodegradation. The overall Pearson coefficient determined at 95 % confidence interval (-0.82) indicated a moderate correlation between biodegradation and SUVA.

Figure 5.50 depicts the removal of NOM related parameters over the experimental period. The 95% confidence intervals are also shown in the figure. The number of data points to determine the confidences were 189 for Norit 1240 and 145 for CAgran.

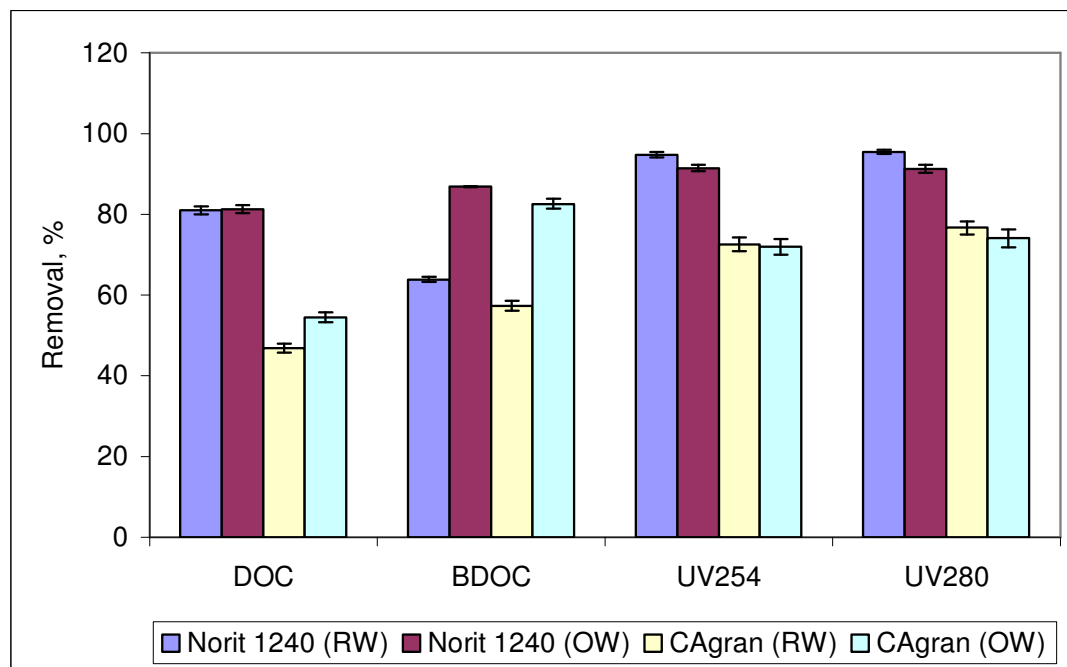


Figure 5.50 The overall average removal in terms of specific parameters (RW: Raw Water, OW: Ozonated Water)

Before the breakthrough in the CAgran column, approximately 90% of the UV_{254} absorbing species were removed from raw water, whereas after breakthrough, this removal decreased to 70%. For ozonated water, after the breakthrough, the UV_{254} removal percentage by biodegradation was the same as the raw water.

The results suggest that removal of UV_{254} in the whole treatment process was a little greater than the removal in DOC. Ozonation of raw water led to a larger decrease in UV_{254} compared to DOC. The decrease of UV_{254} can be attributed to degradation of compounds with double bonds.

pH values were also recorded during the 220 days of operation. The results were shown in Figure 5.51. As expected, ozonation did not change the pH of raw water. The effluent pH values for CAgran ranged between 7.36 and 8.30 and for Norit 1240 between 7.37 and 8.29. pH is an important parameter for nitrification and bacterial activities. Optimum pH should be between 7-8.5. Measured pH values were satisfactory for nitrification, bacterial growth, metabolic activities and carbon removal.

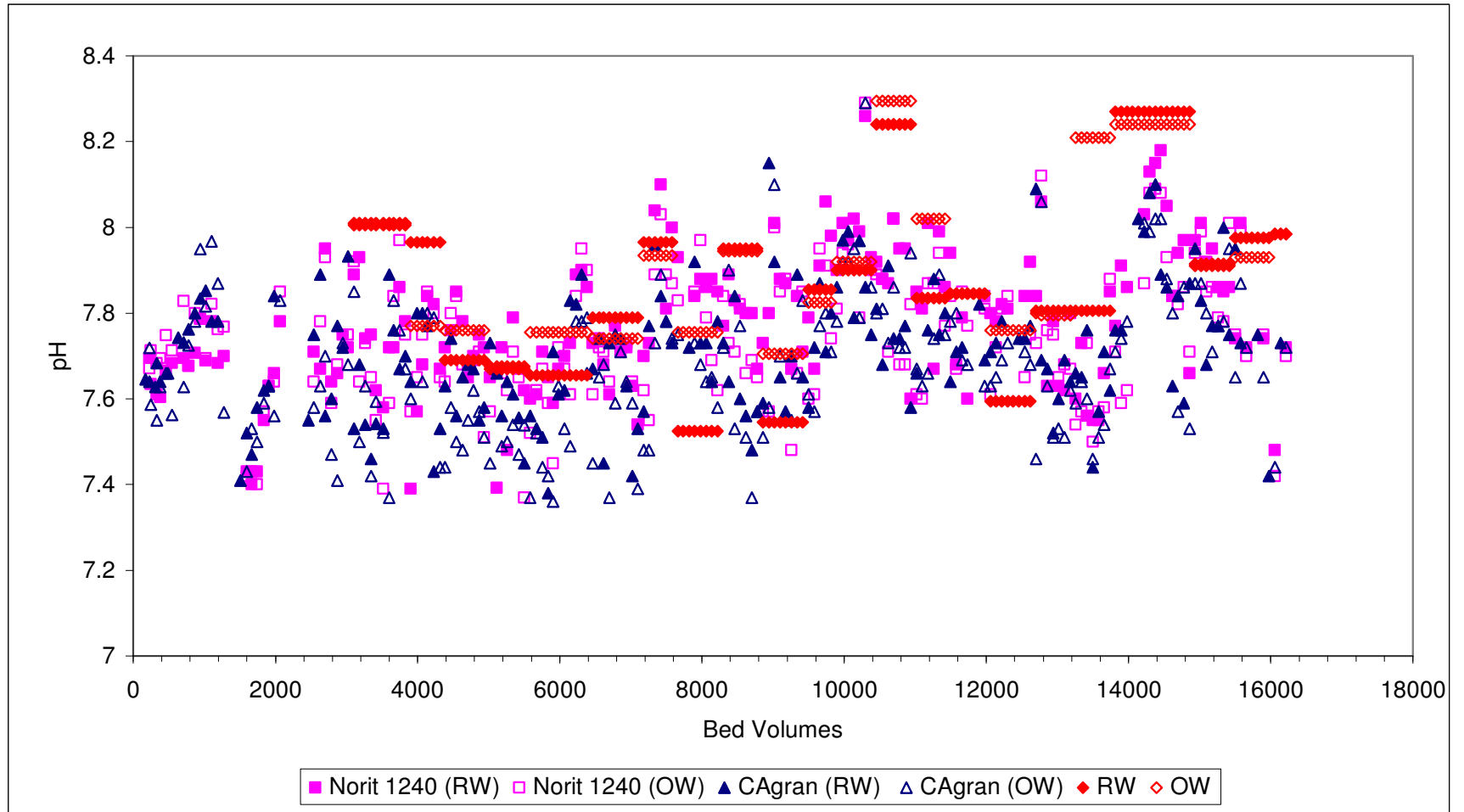


Figure 5.51 Influent and effluent pH values of the continuous-flow BAC columns (RW: Raw Water, OW: Ozonated Water)

5.4.3.5. Operation of Norit 1240. As previously explained, Norit 1240 is a coal-based and steam activated carbon. It had the best adsorption performance among the GACs tested. In continuous-flow column experiments, it was shown that CAgran reached breakthrough within 2000 bed volumes. On the other hand, during the 220 days of operation (approximately 18000 bed volumes), breakthrough did not commence for Norit 1240. The average effluent DOC concentration for the column operated with raw water and ozonated water was 0.69 mg/L and 0.66 mg/L, respectively. Effluent DOC concentrations remained constant regardless of influent DOC concentration. The average DOC removal efficiency in both columns was 81%. Therefore, no enhancement of DOC removal could be observed in the ozonated water. The performances of the DOC removal were previously presented in Figure 5.38.

Samples taken from the ports at different bed volumes demonstrate the DOC, ammonium and the dissolved oxygen concentration profiles at different depths. Results were compiled in Figure 5.52 and Figure 5.53.

Since Norit 1240 has a high reactivity towards oxygen and chemisorbs it on its surface, the oxygen consumed through the depth of the column cannot be taken as a measure of bacterial activity. In the sterile Norit 1240 column, the dissolved oxygen concentration at the bottom port was as low as 0.84 mg/L (Figure 5.36). In the biologically active Norit 1240 column (BAC), despite biological activity, the dissolved oxygen concentration did not further decrease. In fact, concentrations were higher compared to sterile GAC columns. This can be due to carbon aging. Sampling from ports were done in BAC columns at a much later time than that of sterile columns. It is reported that activated carbons are gradually oxidized in the presence of oxygen (Çorapçioğlu and Huang, 1987). As a result, hydrophobicity of carbon surface decreases, leading to reduction in uptake of hydrophobic compounds.

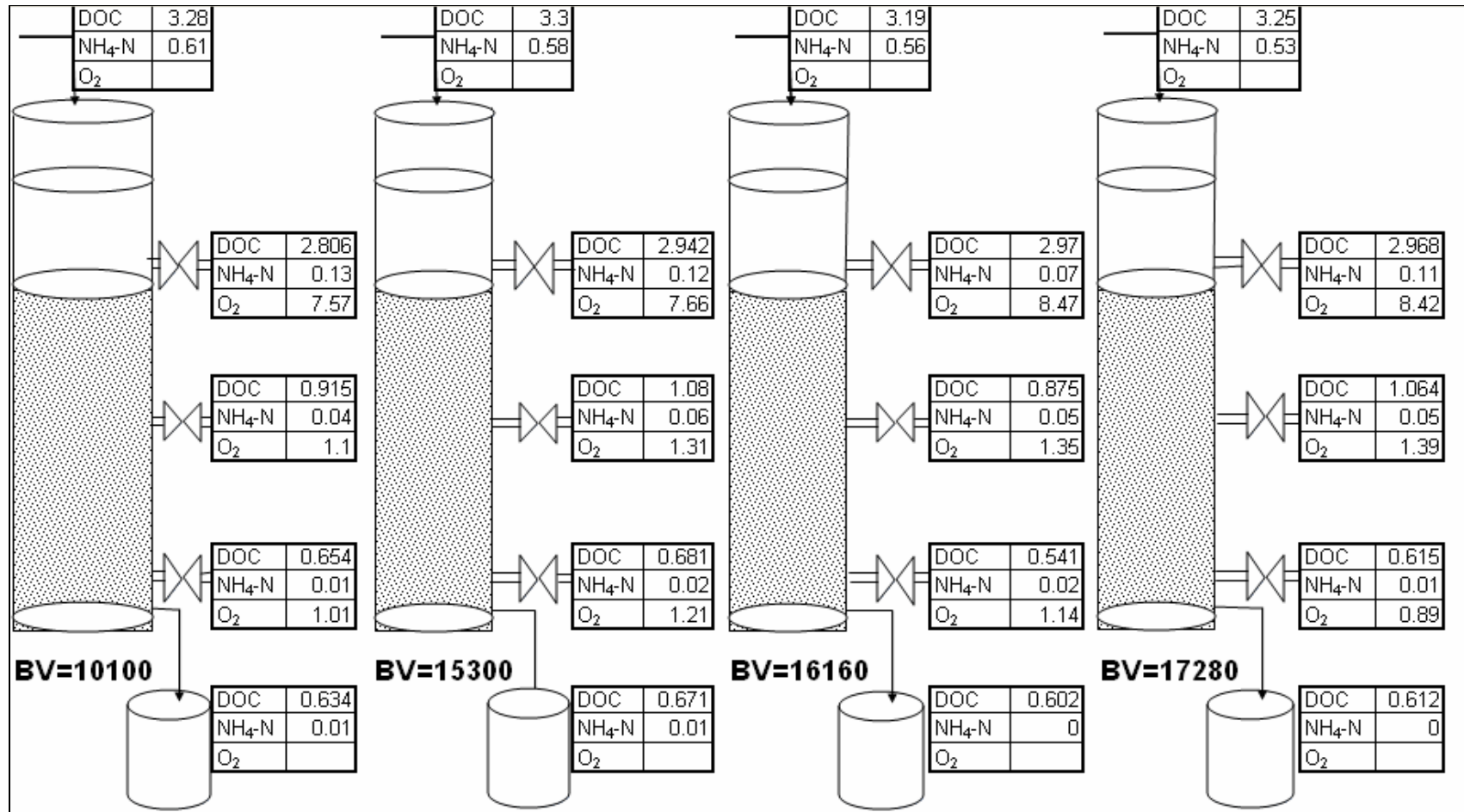


Figure 5.52 Concentrations along the length of the Norit 1240 fed with raw water at different bed volumes (10000 BV corresponds to 125 days after start-up)

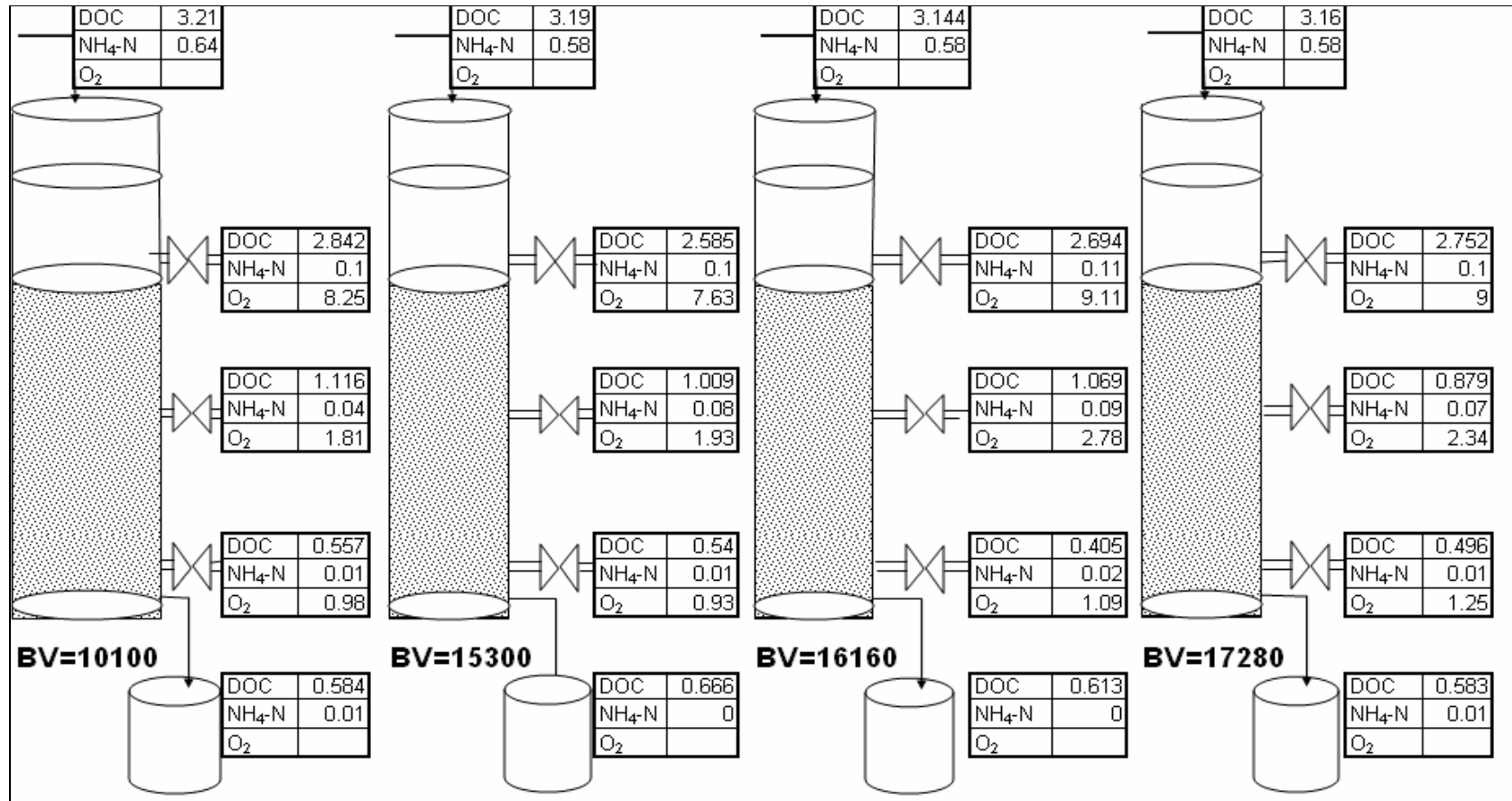


Figure 5.53 Concentrations along the length of the Norit 1240 fed with ozonated water at different bed volumes (10000 BV corresponds to 125 days after start-up)

The most interesting finding in column experiments with Norit 1240 was that, this carbon type can decrease the DOC concentration to at least 1 mg/L by biodegradation. As explained earlier, an adsorption gradient exists in the carbon bed called as the mass transfer zone (MTZ). It corresponds to the gradual transition of the carbon from fresh (or virgin) to spent (or exhausted) and it is the zone in the column where active adsorption is occurring. DOC concentration in the middle port remained constant (around 1 mg/L) during a 7000 bed volume operation. 7000 bed volume corresponds approximately to 87 days of operation. In 7000 bed volumes, the mass transfer zone should have been shifted to lower depths and the DOC loss of the samples taken from the middle port should represent the biodegradation only.

The DOC levels in the bottom port were further reduced to 0.6 mg/L. This concentration was the typical effluent DOC concentration that was observed during 240 days of the column operation. Therefore, in this case it is difficult to state by which mechanism this concentration was achieved in the effluent. The results of molecular studies revealed that bacteria were also present in the bottom port (Section 5.5). So, biodegradation can play a role in the DOC reduction in this region. On the other hand, there is a probability that adsorption is still occurring between the middle and bottom ports. Because an average DOC concentration as low as 1 mg/L entered the lower port, the GAC pores near the bottom may be still not saturated.

5.4.3.6. Comparison of Biodegradation Efficiencies in the Norit 1240 and CAgran Columns. Norit 1240 can decrease the DOC concentration at least down to 1 mg/L by biodegradation which corresponds to 72% removal. On the other hand, 0.6 mg/L of effluent DOC concentration can be due to either biodegradation, adsorption or the combination of both. The removal efficiencies in the columns fed with raw and ozonated water were not significantly different from each other. For CAgran, DOC removal slightly improved when raw water was ozonated; the average DOC removal by biodegradation was 47% for raw water, and 53% for ozonated water. For Norit 1240, there were no differences between the effluent DOC concentration in the case of raw and ozonated water.

Norit 1240 outperformed CAgran not only in terms of adsorption but also in terms of biodegradation. The adsorption onto GAC can provide a longer retention time in filters for slowly biodegradable components. The ability of GAC to better adsorb and retain such compounds increases their chance of being biodegraded by bacteria. Thus, biodegradation by attached bacteria can lead to continuous bioregeneration of GAC. It is thought that, probably a couple of years may pass till breakthrough is achieved in the GAC column containing Norit 1240. Thus, using this type of carbon seems to be advantageous.

Some research has suggested that DOC removal can be limited by biomass concentration (Carlson and Amy, 1998). The fact that microporous GAC (Norit 1240) outperformed at NOM biodegradation may also be related with bacterial amount in the biofilters. Prior to column operation, approximately equal amounts of bacteria were added to each column. In general, little biogrowth occurs in GAC micropores because their small diameter (1-100 nm) does not allow penetration of bacteria, which typically have a diameter greater than 200 nm (Urfer et al., 1997). On the other hand, the relative amounts of bacteria in each filter may change during the operation. The pore sizes of GAC can influence bacterial retention and colonization. In a study conducted by Wang (1995), the bacterial concentrations (per g of GAC) on a bituminous-coal based (micro porous), a lignite-coal based (meso porous) and a wood based (macro porous) activated carbon were compared. Although the highest biomass (quantified by phospholipids) was measured in the lignite-based carbon, results showed that small performance differences existed in terms of DOC biodegradation among micro, meso and macro pore GACs. The role of microorganism concentration on biodegradation is unknown in the present system since biomass concentrations were not measured.

Another possibility can be the production of biodegradable carbon on the surface of Norit 1240. The high oxygen consumption at the GAC surface can cause surface catalytic reactions to occur on GAC surface. Surface catalytic processes can convert originally non-biodegradable substances into biodegradable substances (Uhl, 2000). Because Norit 1240 chemisorbs large amounts of dissolved oxygen on its surface, surface catalytic reactions can be the reason of observing more biodegradation than in the CAgran column.

Therefore, choosing the best type of GAC in biofiltration experiments results in better performance not only in terms of adsorption but also in terms of biodegradation, and, hence, better DOC removal performance results in the increase in the service life of the GAC.

Merlet et al. (1992) compared a wood-based GAC with a macroporous structure and a common coal-based GAC with a more microporous structure at full scale. The concentration profiles of both DOC and BDOC were not different in the two GAC filters with an EBCT time of 25 min. However, ammonia removal was significantly improved in the wood-based GAC. But, the DOC removal efficiencies in BAC columns seemed to be higher compared to the results found in the literature. Table 5.9 depicts the compilation of the studies and their DOC removal performances found in the literature.

In the present study, the DOC removals in biofiltration columns were generally higher than other studies found in literature. The average SUVA values of the raw water in the present study were around 2.5. This may indicate that the raw water of Ömerli was not highly aromatic and therefore not recalcitrant to biodegradation. Hozalski et al. (1999) observed enhanced removal of TOC by biodegradation for NOM sources with a lower SUVA value. When this is the case, even a slowly biodegradable compound can be biodegraded on the surface of the carbon, because GAC can provide the necessary retention of organics due to adsorption. This may have resulted in better DOC biodegradation efficiencies compared to results found in literature. In addition to the SUVA value, the molecular weight distribution of NOM is also important for biodegradability (Hozalski et al., 1999) because lower molecular weight compounds are more easily transported across cell membrane and attacked by metabolic enzymes (Leisinger et al., 1981).

Table 5.9 DOC removals typically achieved by pre-ozonation-biofiltration

Water Source	DOC (mg/L)	Media	O ₃ dose	Removal (%)	Reference
River Dee, UK	2.9-6.1 ¹	Sand	<5 mgO ₃ /L	18-55	Mellanby, 1991
Seagahan, UK	NA ²	Sand	3.1-4.8 mgO ₃ /L	25	Gould et al., 1984
Lake Vyrnwy, UK	2.4-4.8	Sand	1.1-2.5 mgO ₃ /L	26.5	Cable and Jones, 1996
Norsborg, Sweden	NA ²	Sand	0.2-1mgO ₃ /mgTOC	20-30	Seeger and Rothman, 1996
River Dee, UK	3.0-7.9	Sand	0.5mgO ₃ /mgTOC	28	Yordanov et al., 1996
Model Water	4.0-5.0 ¹	Sand	6, 7 mgO ₃ /L	34-40	Odegaard, 1996
Plonia River, PL	7.8-11.6 ¹	GAC	1.64 mgO ₃ /mgTOC	39	Seredynska-Sobecka et al. (2006)
Grand River, USA	5-7	GAC		13 to 23	Emelko et al (2006)
Miyun Reservoir	4.9-7.3	GAC	3 mg/L	33.4	Li et al., 2006
Huangpu River	5.2-7.7	GAC	2.0-2.5 mg/L	31	Xu et al., 2007
Ömerli Reservoir	2.9-4.9	GAC	2mgO ₃ /mgDOC	47-72	This study

¹In terms of TOC

²NA: Not available

5.4.3.7. Effect of Ozone on Removal Efficiency. Most of the studies up to now documented the benefits of ozone in enhancing the biodegradability of NOM and leading to higher biodegradation in BAC columns. The effect of ozonation on DOC removal was more obvious when a nonadsorptive media like sand was used. For example, Shukairy et al. (1992) compared the biofiltration efficiencies ozonated and non-ozonated biofiltration columns consisting of sand using the raw surface water of the Ohio River. The percentage of DOC removal approximately doubled when ozonation preceded biofiltration (12% vs. 25%). The same experiments were also done with artificial water, produced using a solution of humic substances isolated and concentrated from ground water. However, DOC removals reported for the artificial water were significantly higher than those observed for any of the previously described studies that used natural waters (34-48% for biofiltration; 64-72% for ozone + biofiltration). In another study conducted by Moll (1999), ozonation slightly enhanced TOC removal in a biofiltration column made of sand. Ozonation at a dose of 0.9 mg O₃/mg TOC increased the average TOC removal in the filters treating Harsha Lake water from 16% to 25%.

DeWaters and DiGiano (1990) found that preozonation of humic substances obtained from Dismal Swamp resulted in 43% biodegradation of TOC in a fixed bed GAC column reactor (Ozone dose: 1 mg O₃/mg TOC, EBCT=3.9 min; feed TOC=7 mg/L). In contrast, in a study of Glaze (1982), a pilot-scale study was carried out with GAC beds at Shreveport, Louisiana to investigate the combination of ozone and GAC for TOC and THM precursor removal. The results indicated that preozonation did not affect TOC removal at any time and the average TOC removal efficiency in both columns was approximately 26%.

5.4.3.8. ESEM Pictures. Usually a continuous biofilm does not exist on the media in drinking water biofilters. In most cases scanning electron micrography (SEM) has shown only patches of biomass, but not the multilayer biofilms as found in wastewater treatment (Langlais et al., 1991). ESEM analyses of the virgin GAC samples and the samples taken from the 240th day of reactor operation are presented in Figures 5.54 through 5.57.

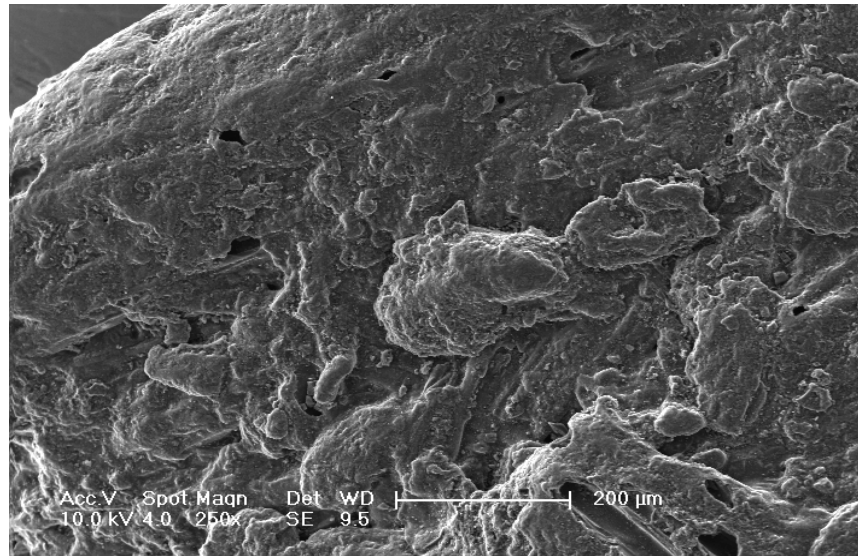


Figure 5.54 ESEM picture of the virgin CAgan

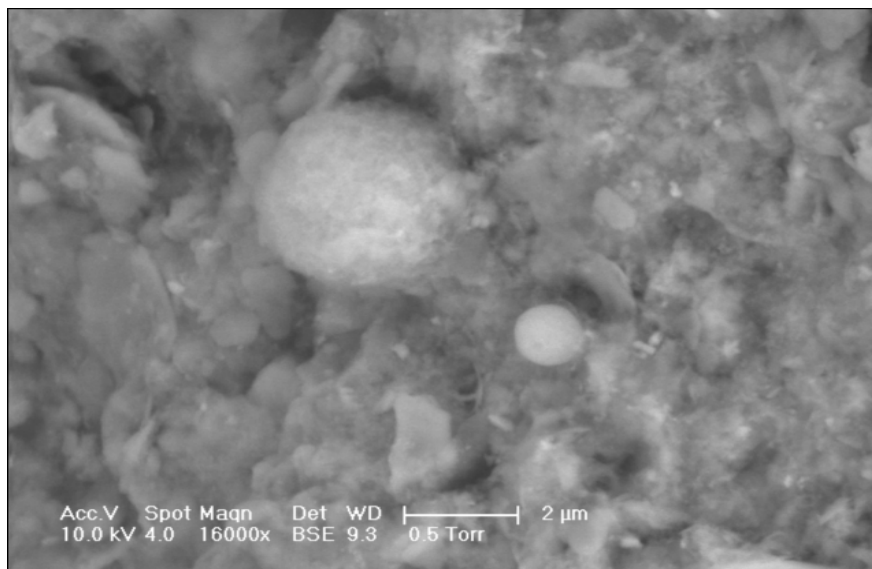


Figure 5.55 ESEM picture of the CAgan at the 240th day of operation

Due to the failure of ESEM Analyzer, BAC samples had to be stored for three weeks. Although the samples were preserved at 4°C in refrigerator, it is thought that most of the bacteria were lost through bacterial lysis. Higher organisms were seen during the analysis rather than bacteria. Other ESEM images from the BAC can be seen in Appendix D.

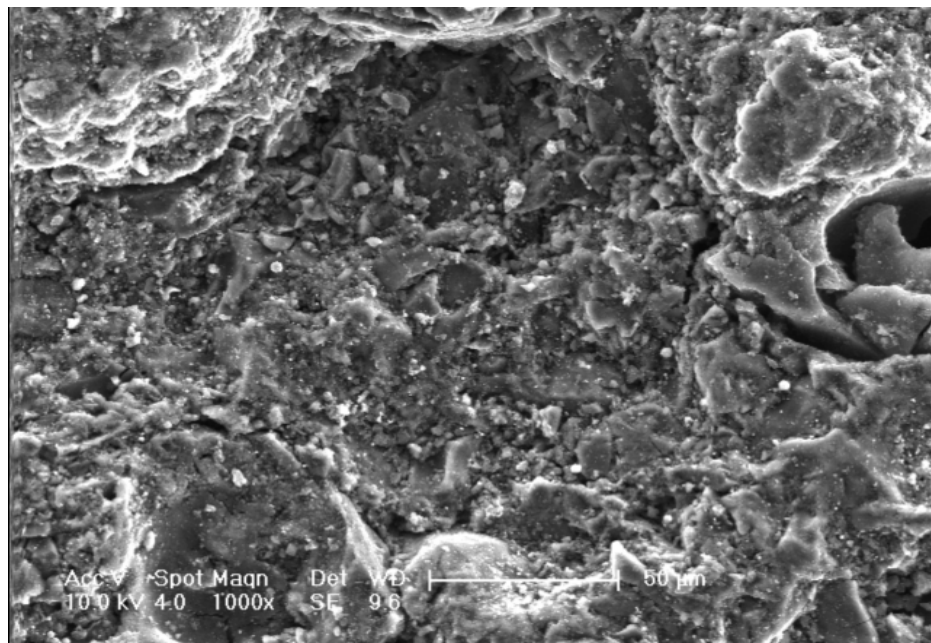


Figure 5.56 ESEM picture of the virgin Norit 1240

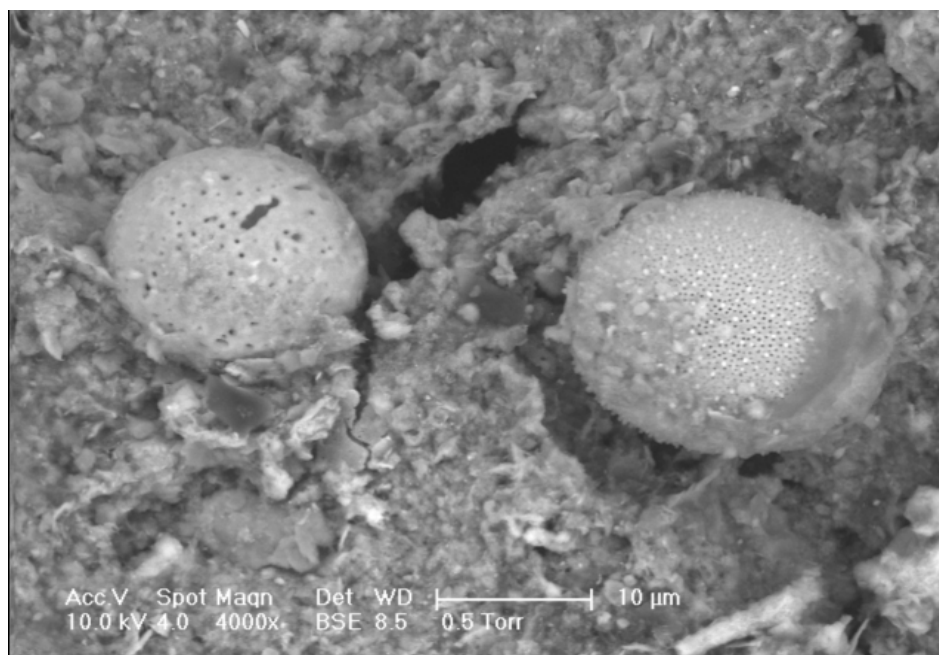


Figure 5.57 ESEM picture of the Norit 1240 at the 240th day of operation

5.4.4. Modeling DOC Biodegradation with Uhl's Model

A dynamic model to predict the removal of BDOC along the column length was formulated by Uhl (2000b). The kinetic expressions of the model were formulated and programmed by the application of the software package Model Maker. The differential equations for each element were solved by a fourth order Runge-Kutta method with variable step-length. The input parameters and constants which were used in the model were summarized in Table 5.10. Simulations describing the influence of various parameters (e.g., temperature, influent BDOC, hydraulic loading etc.) with respect to BDOC removal were shown in Appendix E.

Table 5.10 Simulation parameters for Uhl's Model

Parameter	Model Value	Reference
μ_{\max} (20°C)	0.3 /h	Billen et al., 1992
K_s	0.05 mg/L	Billen et al., 1992
$Y_{x/s}$	0.03 (mg bC/mg DOC)	Uhl, 2000b
bCc	3.08×10^{-10} mg/ μm^3	Fry, 1988
bV	$0.315 \mu\text{m}^3$	Uhl, 2000b
k_d	0.02 /h	Billen, 1988
E_A	33000 J/mol	Uhl, 2000b
$X_{\text{att,max}}$	2.7×10^9 CFU/ml	Uhl, 2000b
k_{att}	1.4×10^{-7} ml/CFU/h	Uhl, 2000b
k_{det}	1.25 /h	Uhl, 2000b
f_{det}	0.5	Speitel and DiGiano, 1987
ϵ_{bed}	0.37	from $(1-\rho_{\text{bed}}/\rho_s)$

Model simulations were solved for the hydraulic loading in this study of 1.67 m/h. The temperature was taken as 25 °C. The results of this model were compared with the experimental results from BAC columns. The results are shown in Figure 5.58 and 5.59.

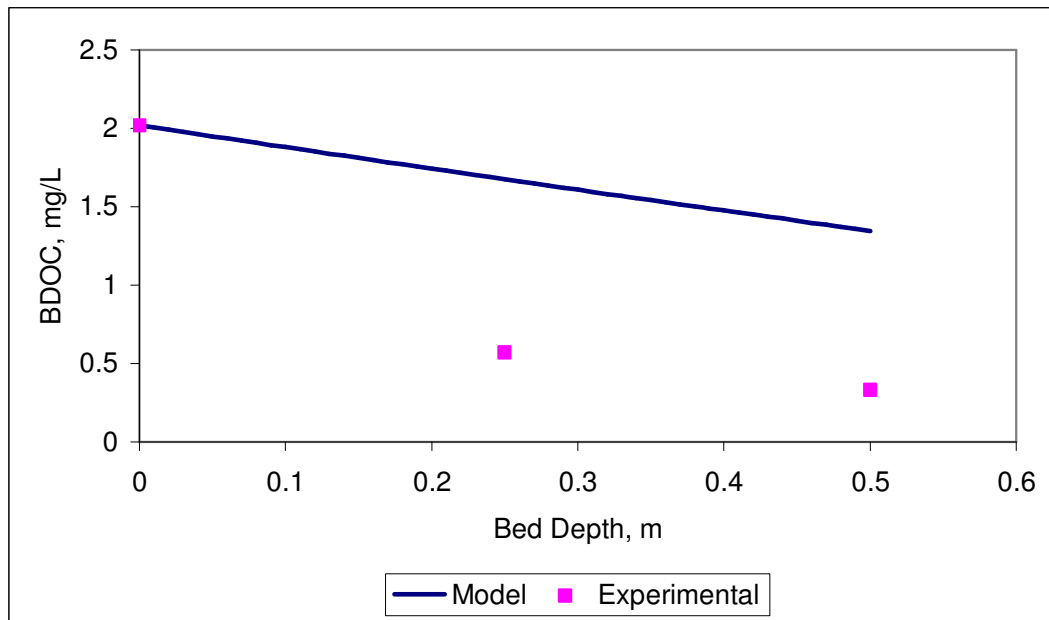


Figure 5.58 Comparison of model simulation with experimental data from the CAgran column fed with ozonated water at Day 130.

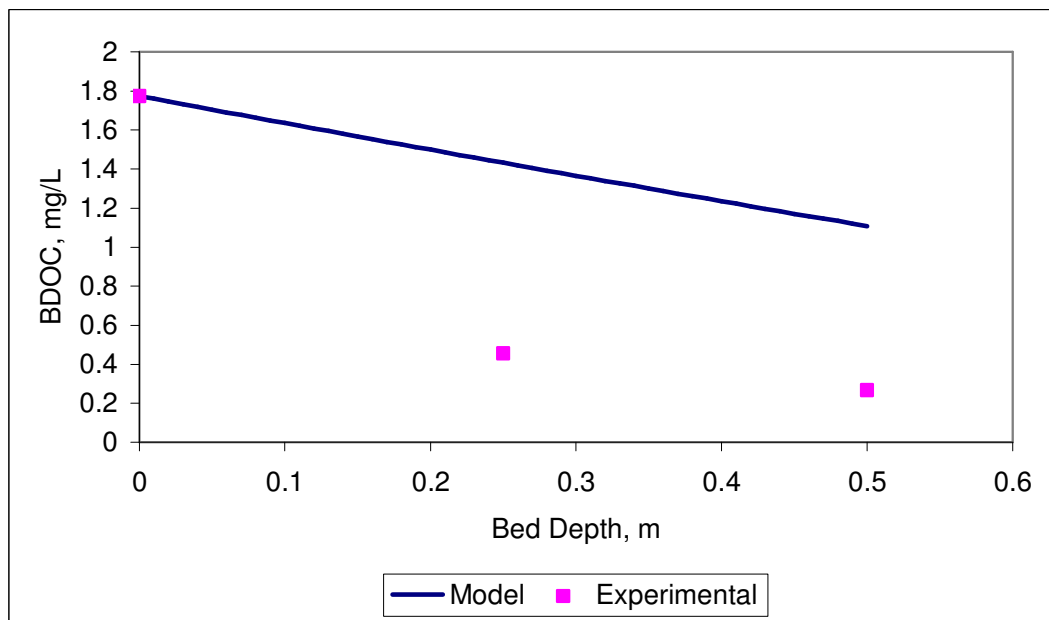


Figure 5.59 Comparison of model simulation with experimental data from the CAgran column fed with ozonated water at Day 185.

Figure 5.58 and 5.59 show that the predictions of the model considerably underestimated experimental results. In the water samples taken from different ports of the columns, it was observed that most of DOC was biodegraded within the first 25 cm of the columns. However, the model failed to simulate this and the values were always higher than real results.

It is considered that Uhl's model takes into account the rapidly biodegradable BDOC only. However, Ömerli water is composed of both rapidly and slowly biodegradable DOC. The slowly biodegradable organics of Ömerli can successfully be treated in BAC columns. In addition to this, according to Uhl's model, only attached bacteria are responsible for substrate utilization and adsorption is not taken into consideration. In the present study, it was seen that the upper part of the columns contained significant amounts of suspended bacteria. Also, it is considered that suspended bacteria above the fixed bed played a significant role in DOC biodegradation. Also, in our case adsorption onto carbon played a significant role in DOC removal. These factors may provide some answers as to why simulations of Uhl's model underestimated the DOC biodegradation in BAC columns.

5.5. Nitrification in BAC Columns and Molecular Investigation of Nitrifying Bacteria

5.5.1. Column Operation

In Section 5.4.3 it was shown that, filtration on biological granular activated carbon (GAC) was a very efficient process for removing biodegradable dissolved organic carbon (BDOC) in drinking water treatment trains. This process can also be used to remove ammonia. The nitrification in biological activated carbon columns and impact of the GAC type on nitrification performance will be the main topics of this section.

The nitrification performance was evaluated in BAC columns fed both with raw and ozonated water. When influent $\text{NH}_4^+\text{-N}$ concentration in the original water was lower than 0.6 mg/L, additional ammonium nitrogen was added into the influent containers. This dosage was chosen because concentration is high enough to see a clear nitrification efficiency and low enough not to cause any dissolved oxygen limitation in the filters. However, between days 60 and 120 the influent $\text{NH}_4^+\text{-N}$ concentration was higher than the 0.6 mg/L, which can be seen in Figure 5.60.

Influent and effluent $\text{NH}_4^+\text{-N}$ concentrations were presented as a function of time, in Figure 5.60. Because of the fact that the columns were biologically active both in terms of heterotrophic and nitrifying bacteria, nitrification started from the first day of column operation. As explained earlier, this was also the case for carbon removal. The thermally activated carbon, Norit 1240, showed an immediate high $\text{NH}_4^+\text{-N}$ removal. For the chemically activated carbon, CAgran, fed both with raw water and ozonated water, 12 days of an acclimation period was necessary for removal of $\text{NH}_4^+\text{-N}$. However, during the operation of the sterile Norit 1240 (Figure 5.34), it was shown that $\text{NH}_4^+\text{-N}$ was reversibly sorbed onto this carbon type in the first five days, and then all of the previously sorbed $\text{NH}_4^+\text{-N}$ was desorbed into the bulk liquid. On the other hand, sterile CAgran did not show any $\text{NH}_4^+\text{-N}$ removal at any time. Therefore, the removal difference in the first days of BAC operation can be attributed to reversible sorption of $\text{NH}_4^+\text{-N}$ onto Norit 1240. In their recent studies, Traenckner et al. (2008) concluded that the efficiency of inoculation to enhance start-up of a nitrifying biofilter depended mainly on the amount of biomass applied and its fixation in the filter. They worked with two parallel sand columns; one of

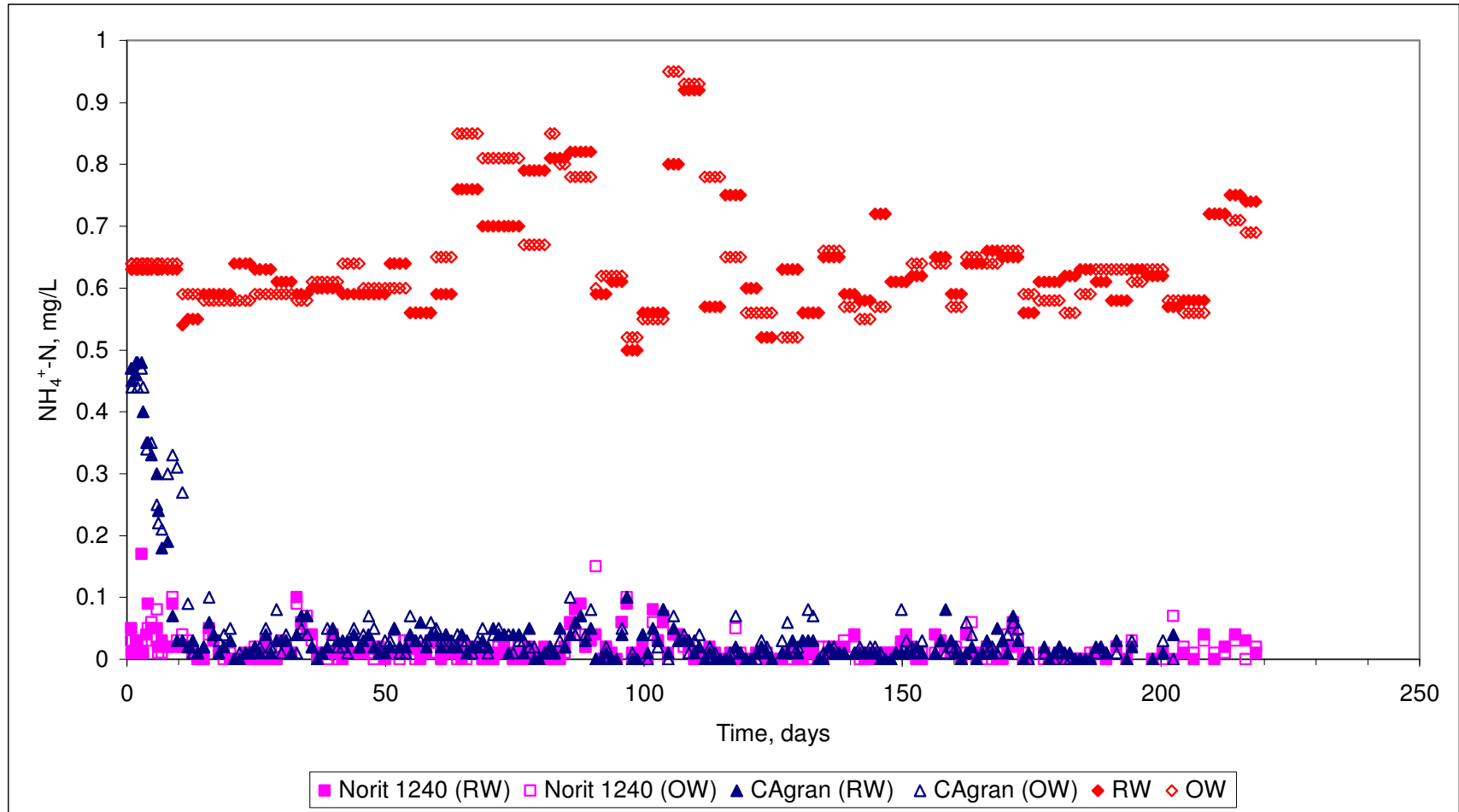


Figure 5.60 Influent and effluent $\text{NH}_4^+\text{-N}$ values of the continuous-flow BAC columns tested with raw and ozonated water (RW: Raw Water, OW: ozonated Water)

them was inoculated with the backwash water of a nitrifying rapid sand filter (Filter 1) and while in the other filter a part of the filter material was replaced with filter material of the same rapid sand filter (Filter 2). They found that ammonia removal developed faster in Filter 2. Full nitrification was achieved after 25 days, while in Filter 1 this was reached after 45 days. Ammonia removal in the present study developed at much earlier times.

At later times of column operation, no significant differences were detected between Norit 1240 and CAgran in terms of ammonium removal. In every case more than 97% of nitrification was observed in each column. Moreover, the effluent concentration did not change, even if the influent concentration increased up to a maximum value of 1 mg/L $\text{NH}_4^+\text{-N}$. These results show that nearly complete removal of $\text{NH}_4^+\text{-N}$ is possible in both thermally activated and chemically activated carbons.

Sampling from ports showed that as soon as the influent water entered the column, nitrification was observed immediately (Figures 5.41, 5.42, 5.52 and 5.53). The water samples taken from the uppermost columns which were 2 cm above the filter media depicted that approximately 83% of the $\text{NH}_4^+\text{-N}$ was removed there. This means that the upper part of the column is well mixed; the dilution effect was seen immediately in the column. These results also show that, heterotrophic bacteria and nitrification bacteria co-exist in the upper part of columns.

In the first 25 cm of both carbon types, much of the $\text{NH}_4^+\text{-N}$ was removed. Approximately 92% of nitrification occurred till this depth. Therefore, higher depths were unnecessary in terms of ammonia removal in the current study.

Ozonation was not expected to affect nitrification. However, it may have only indirect effects. For example, ozonation increases the dissolved oxygen concentration in the feed water. When the $\text{NH}_4^+\text{-N}$ concentration is high in the influent, the dissolved oxygen concentration can become the limiting factor in the reactor due to the oxygen demand of nitrification. Thus, ozonation can increase nitrification efficiency to a certain extent. In addition to this, ozonation can decrease the influent ammonia concentration by oxidizing ammonia to nitrate. But this can happen only when the ozone / ammonium ratio and pH are high. The specific rate constant for ammonia removal by ozone is small and

this constant further decreases below pH 9.5 (Haag et al., 1984). Because influent NH_4^+ -N concentration did not make the dissolved oxygen limiting in filters and ozone concentration was not high, ozonation did not have any effect on the nitrification.

The effluent NO_2^- -N concentrations were reported in Figure 5.61. The average influent NO_2^- -N concentrations for raw and ozonated water were 0.027 mg/L and 0.005 mg/L, respectively. Nitrite concentration in ozonated water was lower than that of raw water since ozonation oxidized nitrite to nitrate. The average effluent NO_2^- -N concentration was approximately 0.02 mg/L in the columns. In some periods, nitrite accumulation took place due to the operational problems (especially in the case of pump failure) but did not continue for a long time. According to EC standards for drinking water (EC 80/779, 1980), 0.05 mg/L of NO_2^- -N is allowed. In biological processes, nitrite accumulation should receive considerable attention, as this inorganic form of nitrogen is toxic to aquatic life and also to humans when present in drinking water. However, the spikes of NO_2^- -N in the effluent can easily be oxidized by chlorination. Post chlorination is usually applied in the water treatment plants after biological activated carbon filtration .

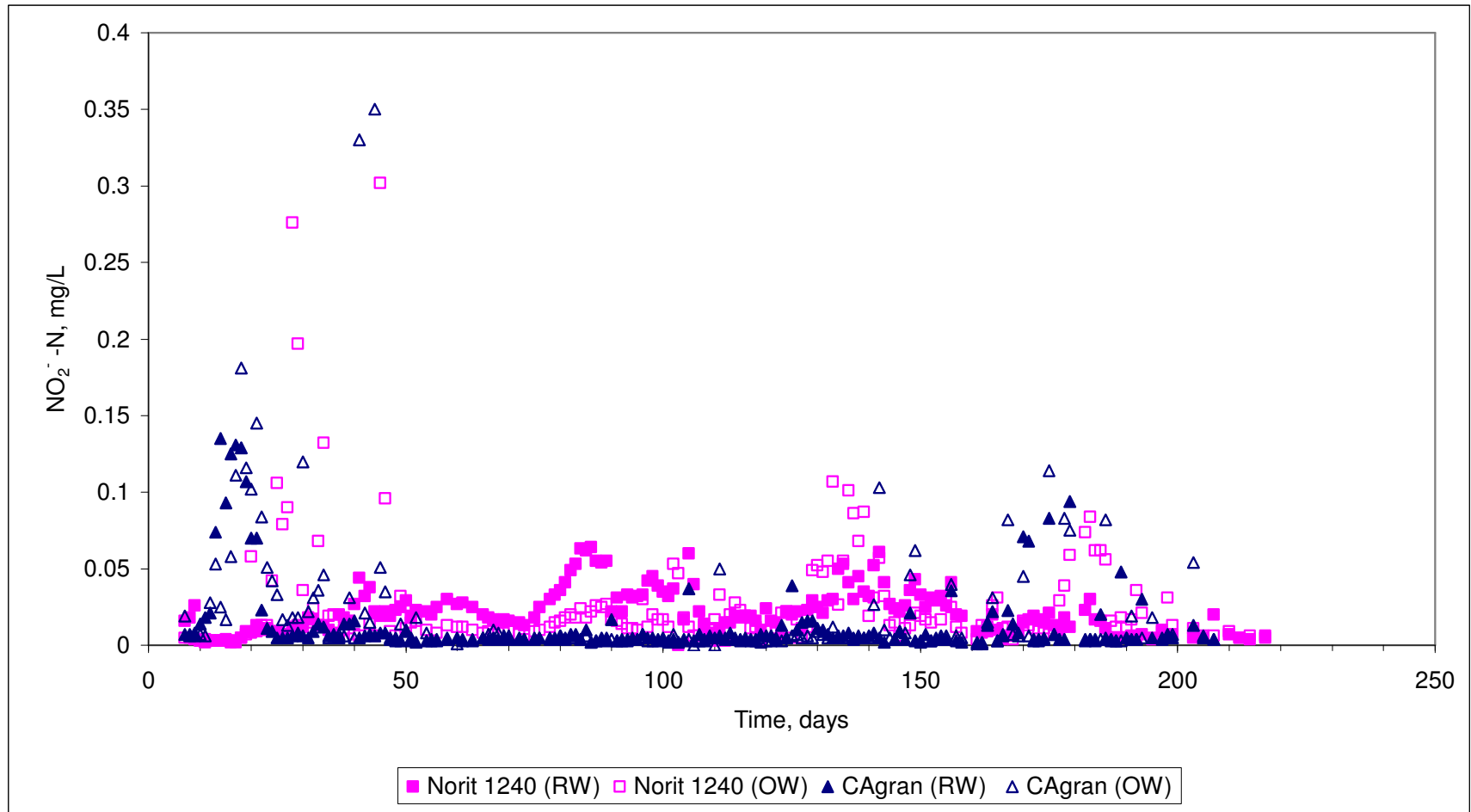


Figure 5.61 Influent and effluent $\text{NO}_2^- \text{-N}$ values of the continuous-flow BAC columns tested with raw and ozonated water (RW: Raw Water, OW: Ozonated Water)

The influent and effluent NO_3^- -N concentrations in columns fed with raw and ozonated water are presented in Figures 5.62 and 5.63. Figure 5.62 shows that influent NO_3^- -N concentration increased in raw water for the first 140 days, and then leveled out at a concentration of approximately 1 mg/L. For the ozonated water (Figure 5.63), the influent NO_3^- -N concentration was higher than that of raw water. The nitrogen gas dissolved in water can be oxidized to nitrate by the oxidative power of ozone at high ozone concentrations. This can be the reason why ozonation increased the NO_3^- -N concentration of raw water samples.

At the first 10 days of the operation, in addition to ammonium ion, nitrate was also sorbed by Norit 1240 which was shown in Figure 5.35. This was the reason why effluent NO_3^- -N concentrations of Norit 1240 were almost zero. Therefore, the low nitrate concentrations at these days cannot be the indication of denitrification.

Figure 5.64 and Figure 5.65 show influent and effluent total nitrogen (TN) concentrations of the columns fed with raw and ozonated water. Total nitrogen is the sum of the organic-N, NH_4^+ -N, NO_3^- -N, and NO_2^- -N. The measurements showed that organic nitrogen was negligible in Ömerli water. In both columns, on average 20 % difference were observed between the influent and effluent TN in both columns. Since bacteria assimilate some part of nitrogen and incorporate it into cell mass, the occurrence of denitrification is not significant in columns.

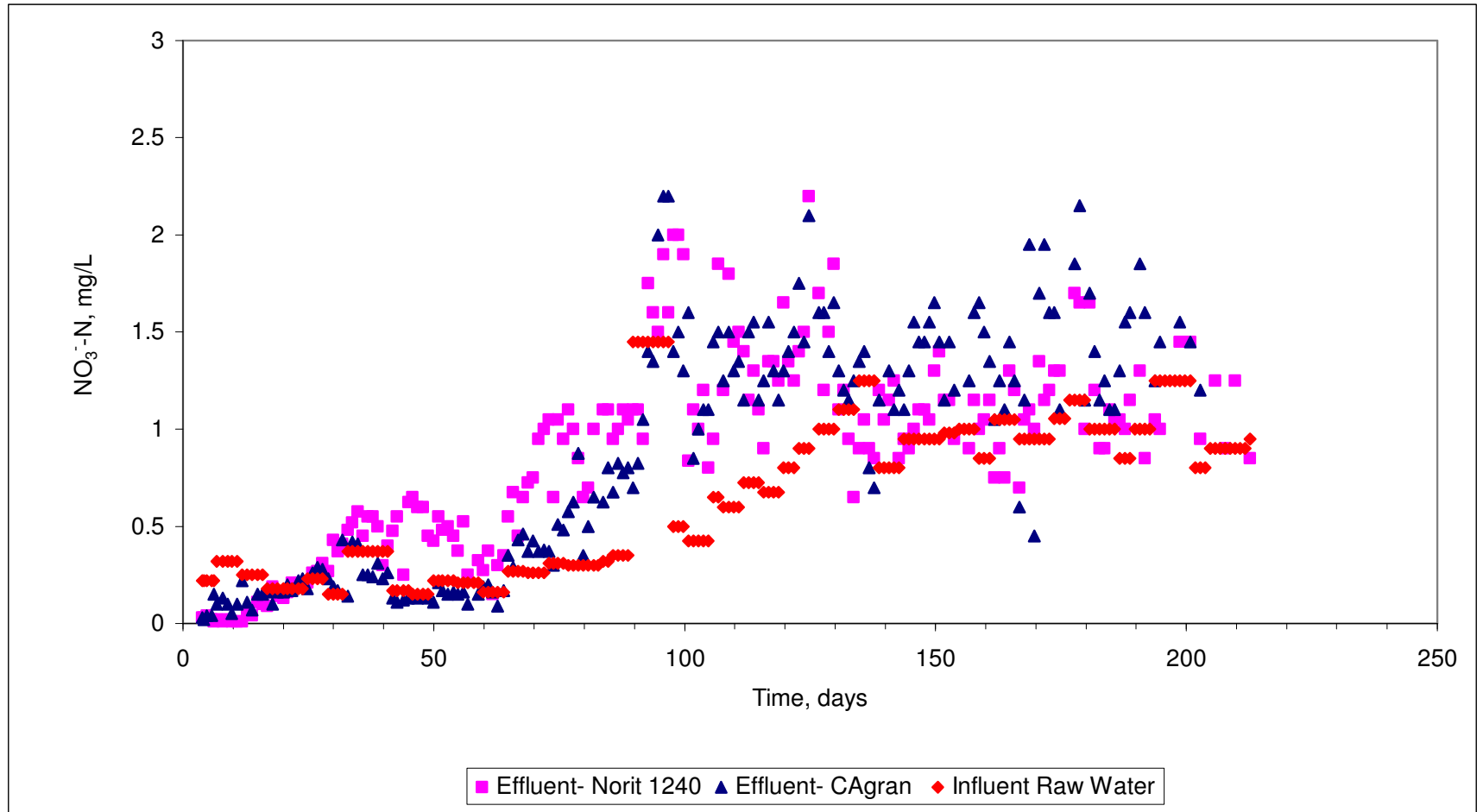


Figure 5.62 Influent and effluent NO_3^- -N values in the continuous-flow BAC columns tested with raw water

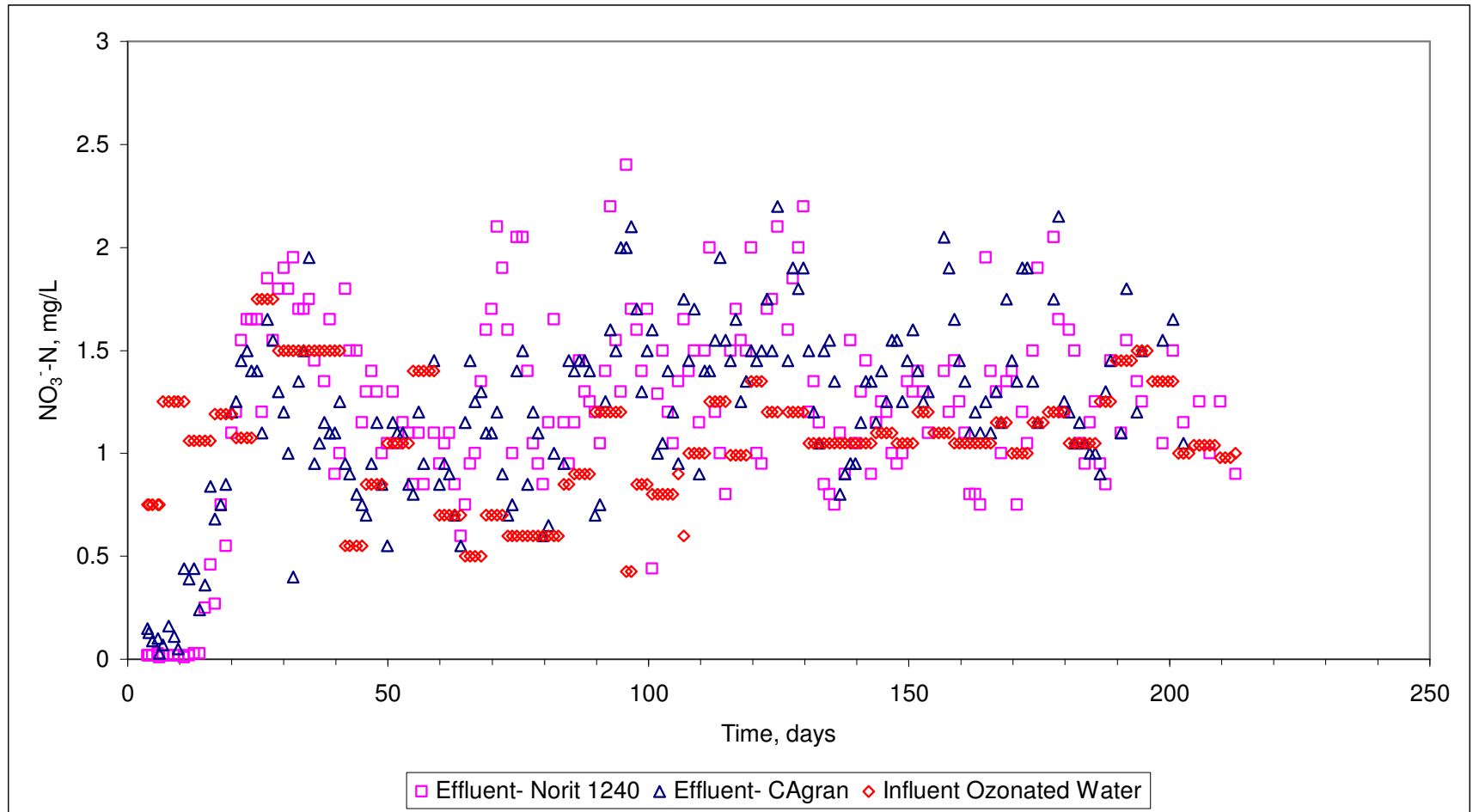


Figure 5.63 Influent and effluent NO_3^- -N values in the continuous-flow BAC columns tested with ozonated water

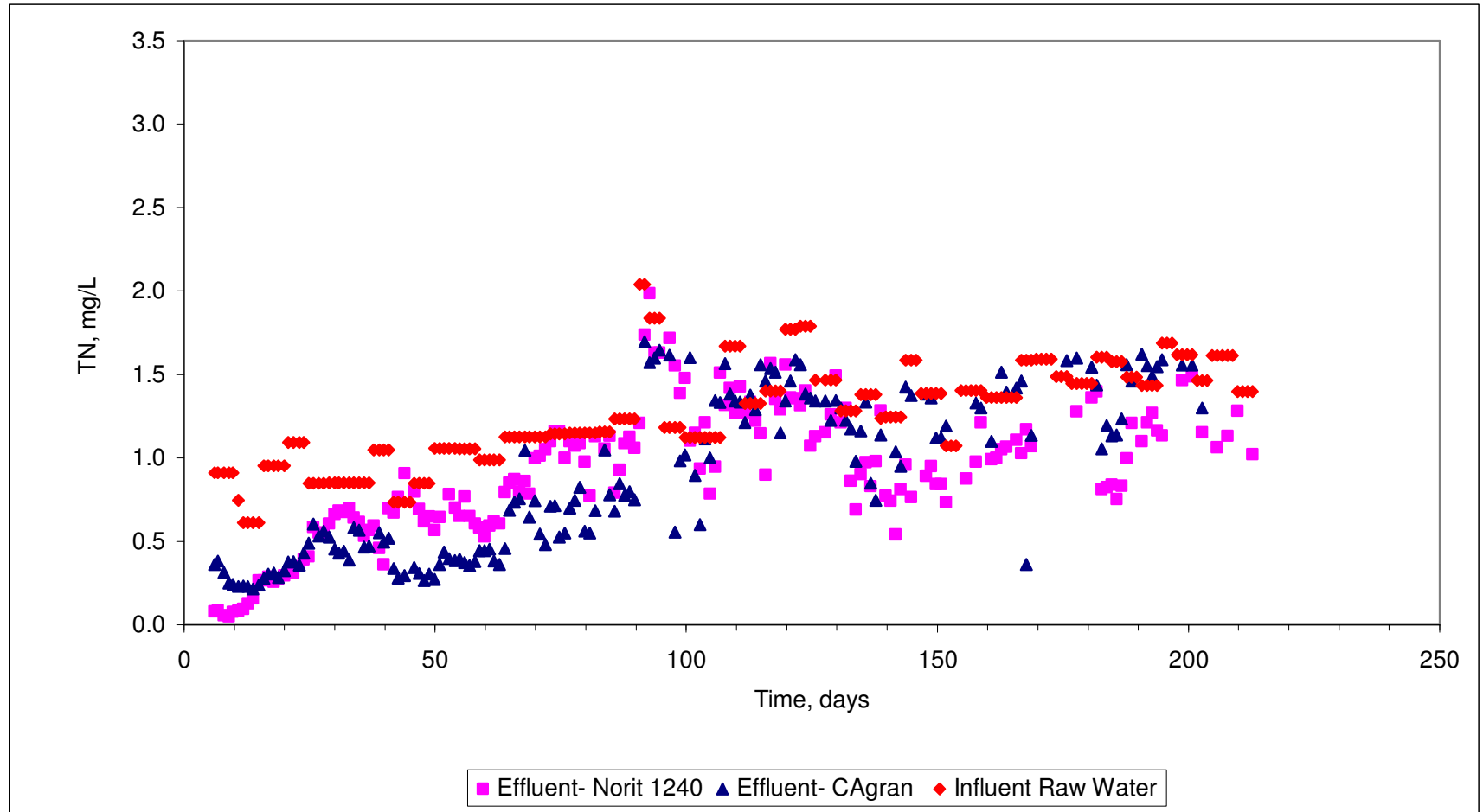


Figure 5.64 Influent and effluent TN values in the continuous-flow BAC columns tested with raw water

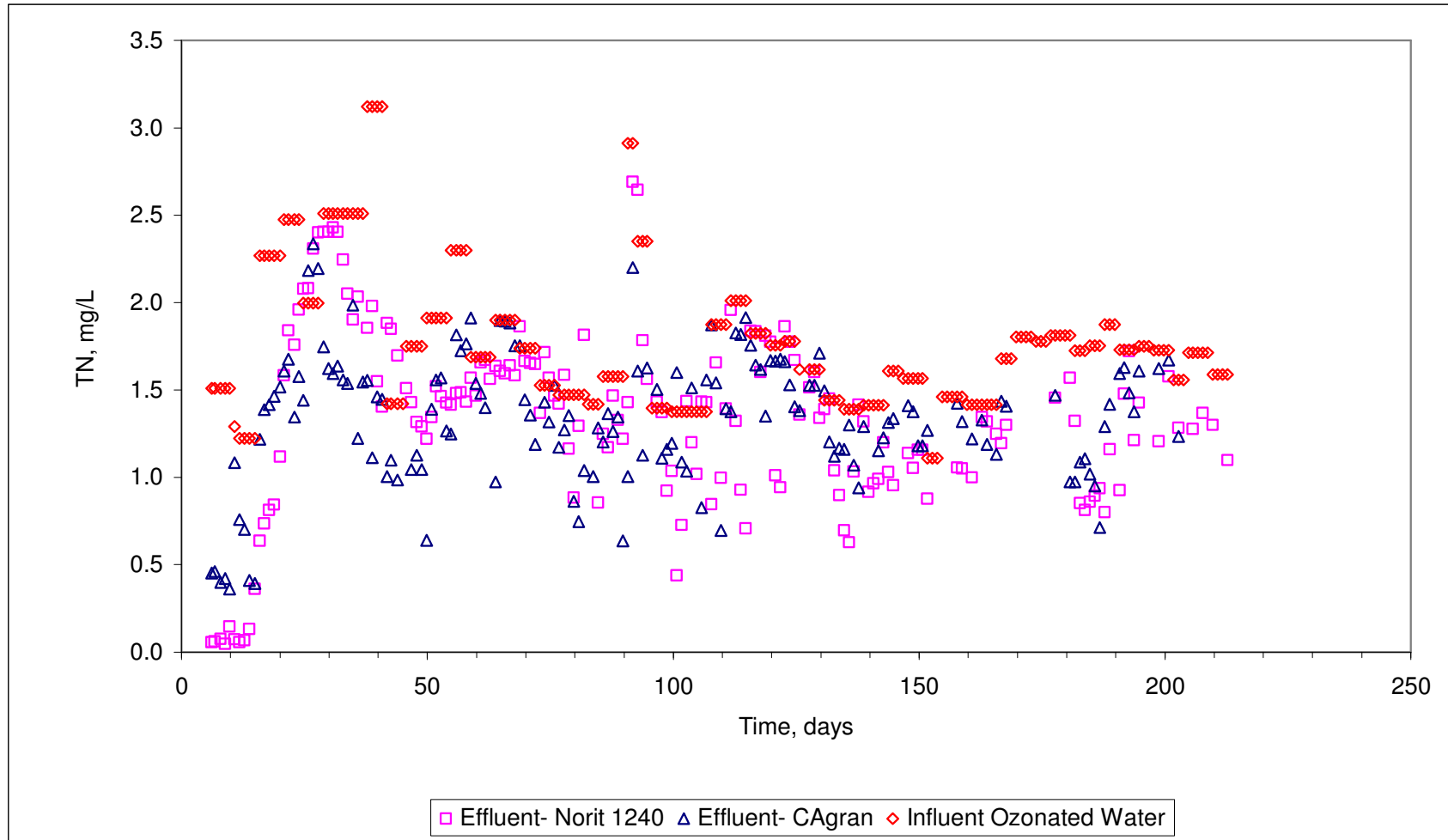


Figure 5.65 Influent and effluent TN values in the continuous-flow BAC columns tested with ozonated water

5.5.2. Molecular Investigation of Nitrifying Population

Biological oxidation of ammonia is well-established in the wastewater treatment field (Metcalf & Eddy 2003). In the drinking water field, biological nitrification to oxidize ammonia from source water has not been widely reported. Few studies have shown that temperature, ammonia concentration, filtration material, oxygen concentration and empty bed contact time (EBCT) were the main factors affecting nitrification in biological filters (Prevost et al., 1992; Boillot et al., 1992; Andersson et al., 2001; Kihn et al. 2002; van Hulle et al., 2006; Wert et al., 2008). The choice of a suitable filter medium may have a significant impact on the ability of bacteria in a filter to initiate and maintain nitrification under plant operation, especially when external conditions are unfavorable (low ammonia concentrations and/or low temperatures) (Kihn et al., 2002). EBCT has been shown to be the key parameter in the removal of ammonia for filtration velocities of 10 to 15 m/h (Prevost et al., 1992). Wert et al. (2008) reported that nitrification was reduced by 60% with an increase in filtration rate from 4.8 m/h to 14.6 m/h. The use of different filter media in nitrification has been investigated by several authors (Bablon et al., 1988; Kihn et al., 2002). The structure of the medium seems to impact directly on the number of attachment sites available to bacteria and the level of shear stress to which the bacteria are exposed during filtration and backwashing.

In addition to this, some researchers used mathematical modelling as a tool for analysis and optimisation of a nitrifying biofilter (van Hulle et al., 2006; Queinnec et al., 2006; Traenckner et al., 2008). Kihn et al. (2000) developed a technique to estimate fixed nitrifying biomass (sum of ammonia- and nitrite-oxidizing populations). The quantification of autotrophic nitrifying biomass was determined by potential nitrifying activity measurement.

Although the processes occurring in nitrification columns are well-understood, the microbial community of nitrifiers responsible for nitrification has not been investigated in detail in drinking water biofilters. In order to fully understand and characterize the nitrifier communities and activities in biofilter systems, knowledge of their structure, diversity and function is necessary. In this study, the nitrifiers' structure, diversity and function in BAC

columns were investigated using 16S rDNA and *amoA* gene based molecular microbiology techniques.

The samples were taken from the suspended batch reactor and BAC columns to characterize nitrifiers. The sampling information was presented in Table 5.11.

Table 5.11 Sampling information for Slot-Blot Hybridization and DGGE

Sample Name	Location of the Sample	Sample Date-Day
K1	Batch reactor (inoculum)	15.08.2007-0
K2	Norit 1240 fed with raw water, uppermost part	13.12.2007-125
K3	Norit 1240 fed with ozonated water, uppermost part	13.12.2007-125
K4	CAgran fed with raw water, uppermost part	13.12.2007-125
K5	CAgran fed with ozonated water, uppermost part	27.03.2008-220
K6	Norit 1240 fed with raw water, upper part	27.03.2008-220
K7	Norit 1240 fed with raw water, middle part	27.03.2008-220
K8	Norit 1240 fed with raw water, lower part	27.03.2008-220
K9	Norit 1240 fed with ozonated water, upper part	27.03.2008-220
K10	Norit 1240 fed with ozonated water, middle part	27.03.2008-220
K11	Norit 1240 fed with ozonated water, lower part	27.03.2008-220
K12	CAgran fed with raw water, upper part	27.03.2008-220
K13	CAgran fed with raw water, middle part	27.03.2008-220
K14	CAgran fed with raw water, lower part	27.03.2008-220
K15	CAgran fed with ozonated water, upper part	27.03.2008-220
K16	CAgran fed with ozonated water, middle part	27.03.2008-220
K17	CAgran fed with ozonated water, lower part	27.03.2008-220

During the 220 days of the column operation, higher number of samples were taken for molecular identification. However, it was not possible to extract the DNAs of some of the samples. Samples contained both bacteria and GAC, therefore, it was considered that difficulty was mainly due to adsorption of DNA by the granular activated carbon.

5.5.2.1. Fluorescent in-situ Hybridization (FISH). To eliminate potential biases introduced by DNA extraction, PCR amplification, and cloning methods, fluorescent in situ hybridization technique in combination with different specific fluorescently labeled oligonucleotide probes targeting the ribosomal RNAs have been successfully used to determine communities of nitrifiers. Confirming with the nitrification activity, intensive amounts of *Nitrosomonas-like* ammonia oxidizers and *Nitrospira* related nitrite oxidizers were identified as the major nitrifying bacteria according to the FISH analysis (Figure 5.66). Figure 5.66 belongs to the some FISH pictures from the Norit 1240 column fed with raw water taken at Day 125. The other FISH probes indicated in Table 4.6 were also applied to the BAC samples. However, because of the presence of activated carbon in samples, high autofluorescence were seen in the background. This prevented capturing clear images which in turn did not enable quantification of target species. *Nitrospira* and *Nitrobacter* species were not detected in BAC columns.

Due to problems associated with identification of nitrifying bacteria by cultivation techniques, several culture-independent molecular techniques have been investigated including fluorescent in-situ hybridization (Wagner et al., 1995; Mobarry et al., 1996; Juretschko et al., 1998; Schramm et al., 1999; Daims et al., 2001), slot-blot hybridization using oligonucleotide probes (Mobarry et al., 1996; Mertoglu, 2006), and real-time PCR based methods (Harms et al., 2003; Petersen et al., 2004; Geets et al., 2007). Although *Nitrobacter* is the most commonly isolated and studied nitrite oxidizer generally associated with environmental samples, recent researches revealed that *Nitrospira* is more prevalent than *Nitrobacter* species in nitrite oxidation environments (Juretschko et al., 1998; Okabe et al., 1999; Daims et al., 2001). Juretschko et al. (1998) showed that *Nitrospira*-like bacteria were present in activated sludge systems. Their slow growing nature may have foiled attempts to isolate them. But using FISH they were found to be more dominant than *Nitrobacter* and to occur in co-aggregated microcolonies with *N. mobilis*. Okabe et al. (1999) reported that *Nitrospira*-like nitrite oxidizers were present in the deeper parts of the biofilms where the O₂ concentrations were rather low and *Nitrobacter* spp. compete well only if both oxygen and nitrite concentrations are quite high. Daims et al. (2001) also speculated that nitrite-oxidizing bacteria of the genus *Nitrospira* are key nitrifiers in natural environments. Pure cultures of these organisms are unavailable, but cultivation-

independent molecular methods make it possible to detect in environmental samples and to investigate their ecophysiology.

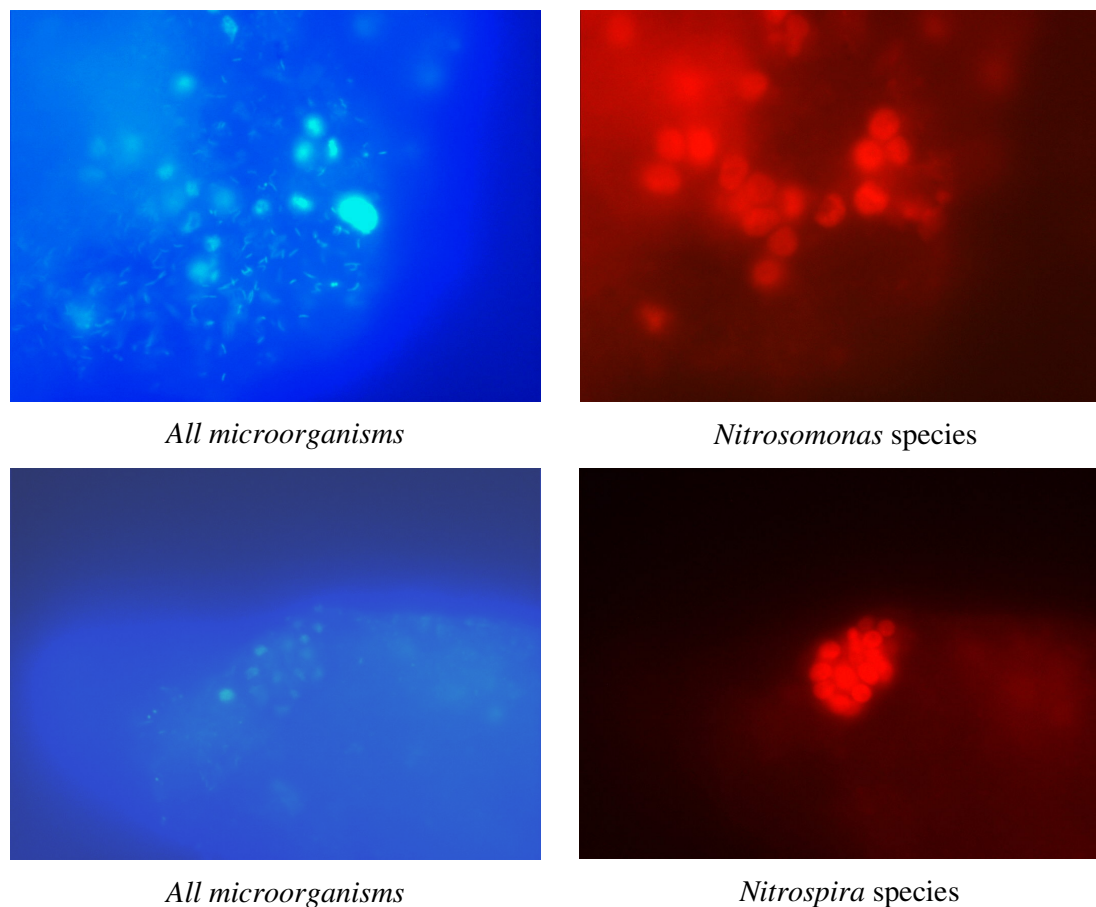


Figure 5.66 In situ identification of nitrifiers in Norit 1240 fed with raw water at Day 125. Samples were hybridized with *Nitrosomonas* and *Nitrospira*-specific probes (labeled with Cy3). All microorganisms stained with DAPI (blue). Blue and red couples represent the same fields of the microscopic view.

5.5.2.2. Slot-Blot Hybridization. In addition to in-situ assay used to study nitrification performances, comparative evaluation of nitrite oxidizing bacterial population were monitored using slot-blot hybridization technique with oligonucleotide probes Nit3 and Ntspa662, which is complementary to a sequence region of all *Nitrobacter* species and nitrite oxidizers *Nitrospira* aggregates. Similar to the FISH experiments, the results of slot-blot experiments with group-specific oligonucleotide probes indicated that *Nitrospira*-like

organisms were detected as the prevailing nitrite oxidizing bacteria in BAC columns (Figure 5.67). It was also shown that dominant NOB population was not changed during the operational period in BAC columns and between the Norit 1240 and CAgran. On the other hand, only very few hybridization signals were detected with *Nitrobacter* specific oligonucleotide probes at the bottom sampling ports (Figure 5.67). Dissolved oxygen levels at the bottom sampling ports of CAgran fed with raw water and ozonated water were approximately 3 mg/L and 4 mg/L, respectively. Dissolved oxygen concentrations in the bulk liquid in the Norit 1240 columns fed both with raw water and ozonated water were around 1 mg/L. In this case, *Nitrospira species* were dominant at higher ports where dissolved oxygen concentrations were high (7-8 mg/L) at the upper parts of the BAC columns. Contrary to this result, Schramm et al. (2000) indicated that when oxygen becomes very low or zero, *Nitrospira* related nitrite oxidizers increased in numbers and substituted *Nitrobacter* species. Due to the low abundance of nitrifiers, extracted DNA was amplified with 16S rRNA bacterial specific primers before being used in slot-blot hybridization according to the previous study (Mertoglu, 2006).

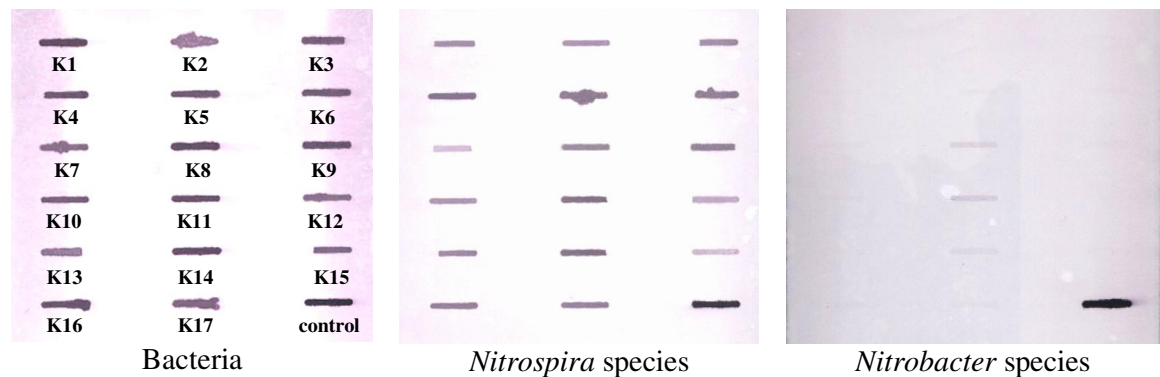


Figure 5.67 Relative differences of NOB in BAC columns. Intensity of the bands is directly proportional to the amount of target DNA. For efficient comparison DIG labeled 1 ng pBR328 control DNA (linearized with BamHI) was applied to each membrane.

The fractions of NOB were analyzed using semi-quantitative slot blot hybridization experiment (Table 5.12). The results showed that *Nitrospira*/total bacteria ratio varies between 3.85% to 28.49% in BAC column.

Table 5.12 Semi-quantitative slot blot hybridization results in a BAC Column

Sample Name	<i>Nitrospira</i> /Total bacteria	<i>Nitrobacter</i> /Total bacteria
K1	3.85 %	< 1.00 %
K2	15.18 %	< 1.00 %
K3	12.04 %	< 1.00 %
K4	16.31 %	< 1.00 %
K5	25.59 %	< 1.00 %
K6	28.49 %	< 1.00 %
K7	3.92 %	< 1.00 %
K8	7.29 %	2.73 %
K9	14.88 %	< 1.00 %
K10	18.40 %	< 1.00 %
K11	24.07 %	4.12 %
K12	16.32 %	< 1.00 %
K13	26.22 %	< 1.00 %
K14	18.38 %	1.95 %
K15	16.90 %	< 1.00 %
K16	9.64 %	< 1.00 %
K17	13.58 %	1.19 %

5.5.2.3. Real-time PCR. Questions about nitrifying community structure and activity in BAC columns have to be solved by means of molecular tools, which allow monitoring of autotrophic AOB/total bacterial community ratio using *amoA* and 16S rRNA gene copies. Observation of how *amoA* and 16S rRNA gene copies vary with time allows monitoring of ammonia-oxidizing activity enables early detection of a decline in the nitrifying population and prevents the washout of these organisms (Dionisi, 2002; Cydzik-Kwiatkowska, 2007). Real-time PCR technology was employed for the quantification of 16S rDNA and *amoA* gene in 17 samples obtained from different ports of BAC columns (Table 5.11 and Figure 5.68). The number of *amoA* gene copy number per micro liter of extracted DNA varied between 7.8×10^3 and 5.5×10^6 . The values for 16S rDNA total bacterial content were considerably higher than the values for *amoA* gene content, ranging from 1.9×10^4 to 6.1×10^6 copies per micro liter of extracted DNA from the samples (Table 5.12). Sampling from

port experiments showed that, the *amoA*/16S rRNA ratio has a decreasing trend through the lower depths of columns. The fact that *amoA* gene numbers were high at the top and low at the bottom may be attributed to the fact that ammonia was removed mainly at the upper part of the column. In port samplings it was shown that approximately 92% of the ammonia and 45% of the DOC was removed in the upper port (Figure 5.41 and 5.42). For this reason, through the lower parts of the column ammonia removal considerably decreased with respect to DOC removal efficiency and this was confirmed by the ratio (Table 5.12). The bacteria sample taken at the Day 125 had high *amoA* and 16S rRNA copy numbers. This was probably due to the fact that the sample taken from the uppermost part of the GAC was expected to contain the highest bacteria concentration. On the other hand, other GAC samples were taken after the shutdown of the biofilter and approximately 15 cm of GAC was taken along with the bacteria so that it contained lower amounts of biomass in Day 220. The comparison of *amoA*/16S rRNA ratio in each BAC columns at day 220 clearly showed that upper sample ports contain more *amoA* gene in comparison with lower ports in where nitrifying bacteria had higher removal efficiency.

Table 5.13 Copy numbers of *amoA* and 16S rRNA genes and the ratios of *amoA*/16S rRNA in BAC column samples as determined by real-time PCR assay.

Sample	Target gene copy number per μL of extracted DNA		
	<i>amoA</i>	16S rRNA	<i>amoA</i> /16S ratio
K1	5.5×10^6	6.1×10^7	8.9%
K2	2.1×10^5	8.1×10^5	25.8%
K3	2.4×10^4	2.0×10^5	11.8%
K4	9.4×10^4	5.9×10^5	16.0%
K5	2.1×10^4	7.2×10^4	28.7%
K6	1.1×10^5	1.8×10^6	6.1%
K7	1.9×10^4	7.2×10^5	2.6%
K8	1.4×10^4	5.3×10^5	2.6%
K9	5.1×10^4	1.2×10^6	4.3%
K10	1.0×10^4	3.1×10^5	3.4%
K11	1.0×10^4	5.0×10^5	2.1%
K12	3.3×10^4	3.2×10^5	10.2%
K13	4.1×10^4	6.5×10^5	6.4%
K14	1.8×10^4	3.0×10^5	6.0%
K15	1.4×10^5	1.6×10^6	8.7%
K16	5.8×10^3	9.2×10^4	6.2%
K17	7.8×10^3	1.5×10^5	5.2%

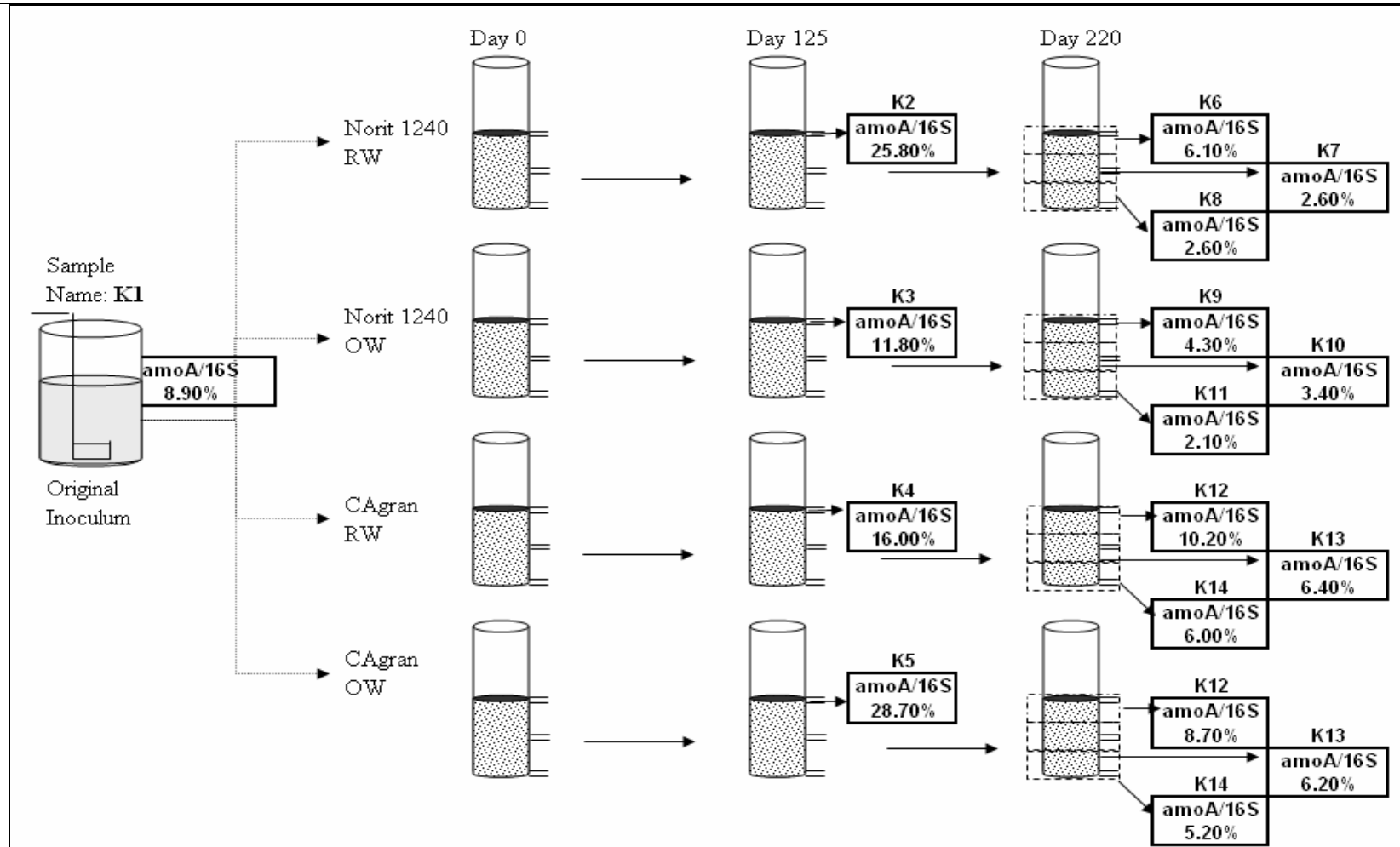


Figure 5.68 The ratios of *amoA/16S* rRNA in BAC column samples (RW: Raw Water, OW: Ozonated Water)

Figure 5.69 shows amplification of 17 samples. As the PCR reaction progresses, the samples begin to amplify in a very precise manner. Amplification occurs exponentially, that is a doubling of product (amplicon) occurs every cycle. A standard curve is used to obtain the concentration of the target and the reference gene. As a result, real-time PCR analysis showed that *amoA*/16S rRNA ratio is an alternative method to understand ammonia oxidizing bacterial population and their activity in BAC columns in comparison with the FISH, cloning and sequence analysis.

In literature, the ratio given for *amoA*/16S rRNA varies from 0.009% (Robinson et al., 2003) to 13.8% (Araki et al., 2004) in natural environments which shows that data are very scattered. However, it is important to bear in mind that different nucleic acid extraction methods exist which influence the quality of extracted DNA. Therefore, differences in extraction procedures affect the *amoA* quantity in samples. Robinson et al. (2003) suggested that either autotrophic bacteria represent a smaller percentage of the total population than values typically used in current design models or AOB and NOB populations were not measured by the newly developed assays. Daims et al. (2001) developed a semiautomated procedure for determining cell concentrations of bacterial populations in complex samples by FISH and CLSM using the area-based quantification method. The percentage of the AOB population was reported as 8.4% for an activated sludge sample obtained from the second stage of a 2-stage wastewater treatment plant. Moreover, *Nitrosococcus mobilis* was detected with a relative in situ abundance of 7% from an industrial plant connected to a rendering factory (Aoi et al., 2004). The authors also indicated that applied DNA extraction methods might not have efficiently lysed all bacteria and actual number of bacteria species might be higher. Real-time PCR assay introduce rapid, reliable information about studies of community dynamics of AOB and NOB in natural and engineered ecosystems. The correlation between the autotrophic AOB/total bacterial community ratio and reactor performances were not investigated in detail. It is important to note that overestimation of the nitrifying population in water or wastewater treatment plant design can substantially increase capital and operation costs due to overcapacity (Dionisi et al., 2002). Therefore, further comprehensive study for nitrifying populations collected by real-time PCR under a wide range of operational conditions are needed for the design of advanced treatment systems.

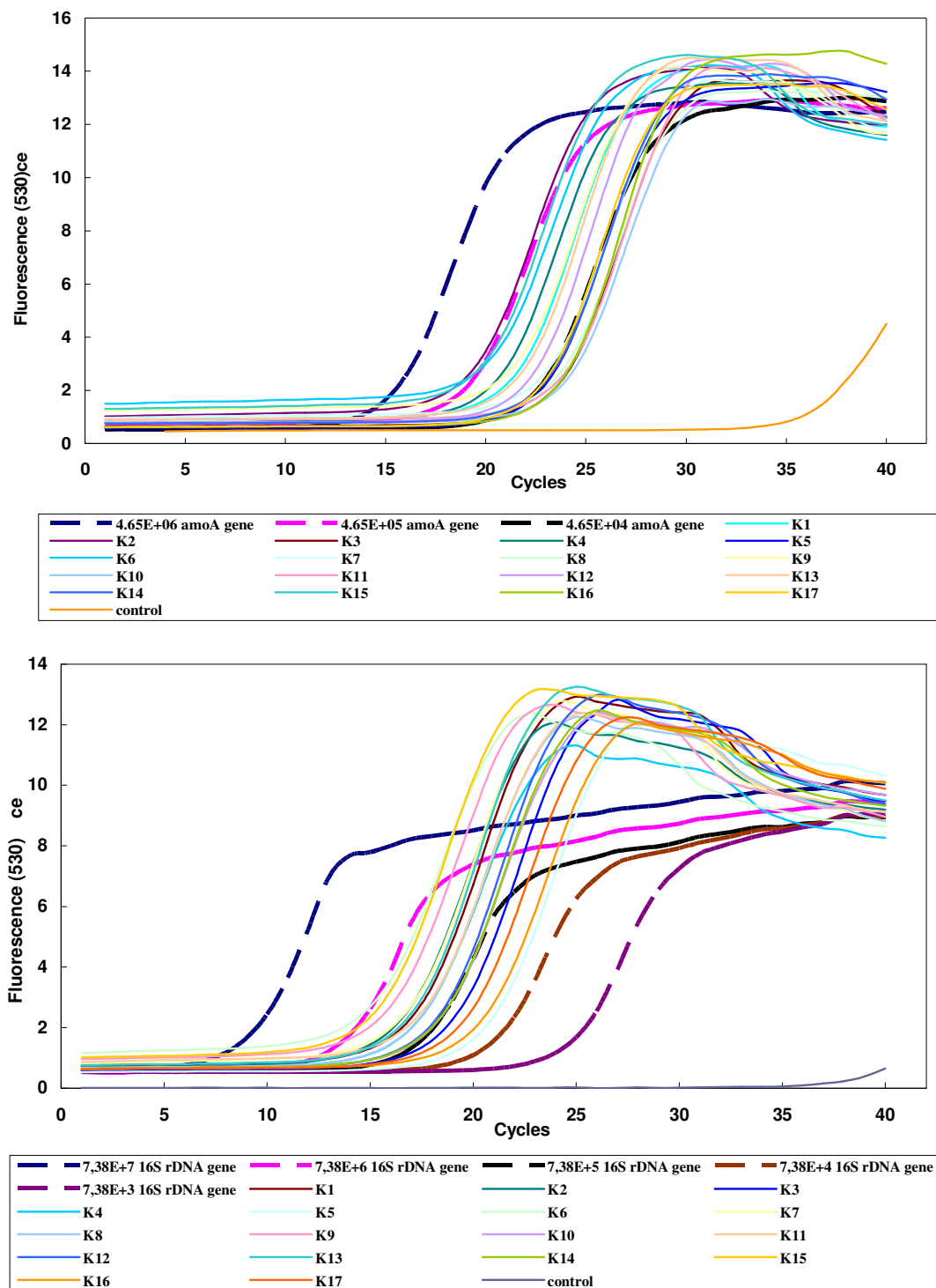
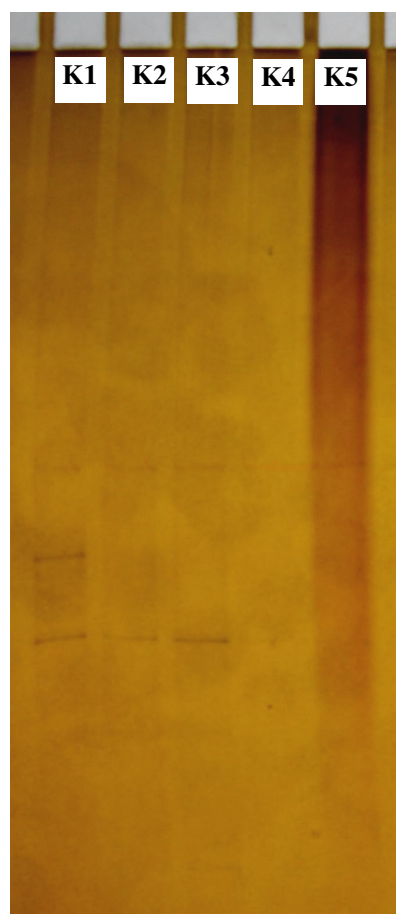


Figure 5.69 Quantitative real-time PCR data and construction of (a) universal 16S rRNA and (b) amoA amplification standard curves. DNA standards are expressed as gene copy numbers.

5.5.2.4. DGGE and Sequence analysis. Denaturing gradient gel electrophoresis (DGGE) experiments is sensitive method to separate DNA's on the basis of single point mutations. Our objective was to evaluate the diversity of ammonia oxidizing bacteria in BAC columns using DGGE and sequence analysis. It was observed that DGGE patterns from the sampling points showed three distinct dominant banding patterns in BAC columns (Figure 5.70). A low diversity was observed in the case of ammonia-oxidizing bacteria in each individual lane. As no significant differences were observed in population structure, K1 and K2 samples were cloned and analyzed for phylogenetic affiliation. Approximately 20 clones picked up and screened by restriction fragment length polymorphism (RFLP) analysis before the sequencing analysis. Phylogenetic analysis demonstrated that all clones contained *amoA* sequences affiliated with the beta subclass ammonia-oxidizing bacteria.



Sample	Location of the Sample
K1	Batch reactor (inoculum) Day 0
K2	Norit 1240 fed with raw water, uppermost part, Day 125
K3	Norit 1240 fed with ozonated water, uppermost part, Day 125
K4	CAgran fed with raw water, uppermost part, Day 125
K5	CAgran fed with ozonated water, uppermost part, Day 125

Figure 5.70 DGGE profiles of PCR-amplified *amoA* gene fragments retrieved from 5 different samples.

In Sample K1, all *amoA* clones were categorized under *Nitrosomonas* species, *Uncultured Nitrosomonas sp. clone Y34*, *Nitrosomonas eutropha* and *Nitrosomonas sp. GH22* (Figure 5.71). In Sample K2, *Uncultured Nitrosomonas sp. clone Y34* species disappeared. A similar banding pattern was observed samples K2, K3, K4 and K5 (Figure 5.70). Apparently, the nitrifier community did not change significantly between Sample K1 and K5.

Clone group *amoA* C1 isolated from K1, K2, K3, K4, K5 sample showed 99.4% similarity to *Nitrosomonas eutropha* and 96.5% similarity to *Nitrosomonas sp. GH22*. Clone group *amoA* C3 isolated from K1 sample showed 97.2% similarity to *Uncultured Nitrosomonas sp. clone Y34* species.

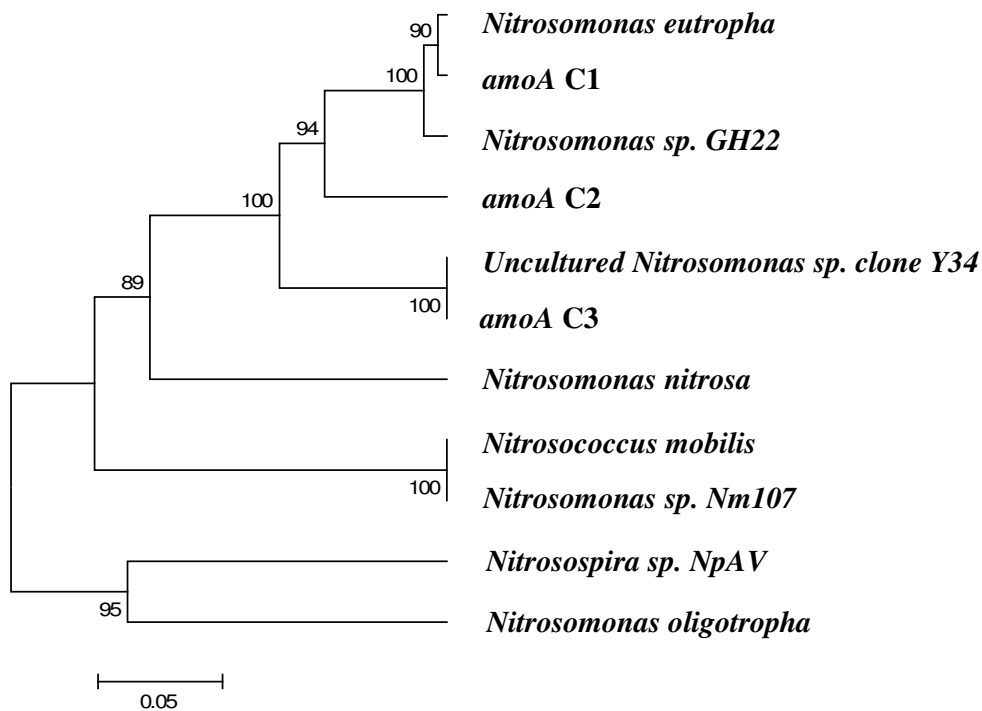


Figure 5.71 A neighbor-joining trees of *amoA* clones. The significance of each branch is indicated by bootstrap values. The scale bar represents 0.05 inferred substitutions per nucleotide position.

The comparison of the community changes in ammonia oxidizers was performed using FISH, DGGE and sequence analysis based on *amoA* and 16S rRNA gene. A

microbial shift was not observed. Nitrite oxidizing bacterial community was analyzed using FISH and Slot-Blot hybridization experiments in BAC columns where *Nitrospira* species were found as the dominant NOB. In our study, at least two different molecular techniques were applied to the samples to eliminate experimental biases.

6. CONCLUSIONS AND RECOMMENDATIONS

In the scope of this study, applicability of biological activated carbon to a drinking water source was investigated in both batch and continuous-flow column experiments. The following conclusions highlight the major results of this study:

This research is composed of three stages. In the first stage, batch experiments were conducted to determine the optimum conditions and materials to be used in continuous-flow biofiltration experiments.

The effect of ozone dosage on BDOC formation was observed by applying ozone at dosages between 0.5-3.0 mg O₃/mg DOC. Ozonation at doses up to 2 mg O₃/mg DOC resulted in very little destruction of DOC. Higher dosages resulted in a distinct decrease in the initial DOC of samples. For the ozonation doses applied up to 2 mg O₃/mg DOC, the results show that, there is a positive linear relationship between the applied ozone dosage and the BDOC formation. The maximum amount of BDOC formed was highest at an ozone dosage of 2.0 mg ozone/ mg DOC. Therefore, this dosage was applied for the preparation of ozonated water for continuous- flow biofiltration experiments.

Batch adsorption and desorption experiments were conducted using GAC that has been activated in different ways. Different water pre-treatments like ozonation, biological treatment, and a combination of ozonation and biological treatment were tested on the raw water. Ozonation did not significantly alter the adsorption behavior of NOM onto thermally activated carbons, but did decrease adsorption onto the chemically activated carbon CAgran.

The surface chemistry of carbon played an important role in adsorption of NOM. GAC types with higher pHPZC (Norit 1240 and Row Supra) exhibited the largest NOM adsorption capacity in water samples because of the electrostatic attractions between GAC and the negatively charged NOM. In general, the adsorption results indicate that the surface chemistry of GAC is more influential than pore structure.

Despite the fact that chemically activated carbon CAgran had inferior adsorption compared to thermally activated carbon in all water samples, it showed better desorbability among the GACs tested. These results may be a key to choosing the optimum GAC type to be used for different applications. If the only aim is to adsorb the NOM from raw water, then one of the thermally activated carbons with high pH_{PZC} such as Row Supra or Norit 1240 can be chosen for treatment. If the aim is to couple adsorption with biodegradation such as in a biological activated carbon (BAC) process, then the right option is to choose a GAC providing a high desorption of biodegradable organics. Desorption of such compounds would result in enhanced adsorption capacity of GAC for nonbiodegradable compounds. While CAgran has the highest desorption, the study clearly demonstrated that adsorption onto CAgran was worse following ozonation of water.

Norit 1240 and CAgran were used in the continuous-flow columns because of their good adsorption and desorption of NOM, respectively. The performances of the sterile CAgran and Norit 1240 columns indicated that DOC removal occurred only by adsorption. The continuous-flow operation of sterile GAC columns showed that, the effluent DOC concentrations for CAgran were higher than in the case of Norit 1240. Besides, Norit 1240 reached breakthrough concentrations at least four times later compared to CAgran. These results showed that the findings of batch adsorption isotherm tests were in good agreement with continuous-flow operation in columns.

The study brought about an advance in the BDOC procedure. The indigenous bacteria in Ömerli water were enriched and this culture was used as an inoculum for the BDOC test instead of using the water sample itself as an inoculum as in the original BDOC test. The applicability and also the efficiency of this modification were tested with standard solutions of acetate and later with raw and ozonated water of Ömerli. Using an acclimated seed resulted in better BDOC readings than the original procedure. For example, in the case of raw and ozonated water, the modified procedure gave 36% and 42% higher BDOC readings compared to the original procedure, respectively. Therefore, BDOC underestimation in the original procedure was corrected and this modification was used throughout the study.

In order to enhance and accelerate the start-up of biological activity inside biological activated carbon columns, this enriched culture was inoculated into GAC columns. Before it was transferred to the columns, this suspended growth batch culture could remove up to 40% of the incoming Ömerli water by biodegradation.

For CAgran, experimental studies done with sterile GAC and BAC columns indicated that, biological activity on BAC columns retarded the onset of breakthrough. Moreover, biologically active CAgran could remove about 47% of DOC by biodegradation only after breakthrough was achieved in the GAC column. DOC biodegradation in the BAC column filled with CAgran was higher than the biodegradation in suspended growth culture. This was attributed to higher efficiency of attached growth systems. In case of Norit 1240, biodegradation efficiencies were as high as 72%. The breakthrough was never reached in this column during 220 days of operation.

The choice of filter material is crucial in BAC systems. The ability of GAC to better adsorb and retain organic compounds increases the chance of biodegradation. This way, slowly biodegradable substances have a better chance to be removed in columns. Therefore, the GAC type leading to best adsorption would probably be the most suitable type for biodegradation as well.

The dissolved oxygen (DO) depletion in the BAC reactor filled with the chemically activated CAgran corresponded relatively well with the calculated theoretical oxygen demand. This suggested that carefully performed DO measurements may serve as an approximation for DOC bioremoval in biofilters. This is of particular interest because of the relative simplicity of DO measurements. However, this approximation is not valid for thermally activated carbons because of the fact that they chemisorb high amounts of DO.

Contrary to the findings of most literature studies, ozonation did not enhance DOC biodegradation significantly. Despite the high increase in BDOC upon ozonation, overall DOC biodegradation efficiencies were not much affected. Since low SUVA values in raw waters already indicate a high biodegradability as shown in our case, ozone application may not be necessary.

High nitrification efficiencies were observed both in the chemically and steam activated carbon types. Presence of AOB was evaluated using FISH, DGGE, cloning and sequence analysis. The results showed that *Nitrosomonas*-like AOB were the dominant AOB in BAC columns. NOB were analyzed using FISH and Slot-Blot hybridization in BAC columns where *Nitrospira* species were found as the dominant NOB. In our study, at least two different molecular techniques were applied to eliminate experimental biases. Real-time PCR using the LightCycler instrument has been used for the quantification of ammonia monooxygenase (*amoA*) and 16S rRNA genes. Results suggested that real-time PCR analysis, *amoA*/16S rRNA ratio, is an alternative method to determine ammonia oxidizing bacterial population and their activity in BAC columns.

In the view of the findings of this study, the following recommendations are made for future researchers:

1. In the present study, high DOC biodegradation efficiencies were observed in BAC columns. The applicability of this process to remove some specific compounds like Endocrine Disrupting Substances (EDS) can be investigated.
2. When influent biodegradable and ammonia concentration are high, oxygen limitation can be seen in the columns. In this case, the removal efficiencies of ammonia and DOC as well as denitrification can be investigated.
3. Further studies are necessary to develop quantitative techniques for nitrite oxidizing bacteria (NOB) to have a better insight into their roles in BAC columns.
4. When bacteria were sampled together with GAC samples, there is a possibility that activated carbon adsorbs extracted DNA during the extraction procedure. This can lead to difficulty in extraction of the DNA. In order to increase the DNA extraction efficiency, different advanced sonication methods can be applied to detach bacteria from GAC.

7. REFERENCES

- Abu-Salah, K., Shelef, G., Levanon, D., Armon, R., Dosoretz, C.G., 1996. Microbial degradation of aromatic and polyaromatic toxic compounds adsorbed on powdered activated carbon. *Journal of Biotechnology*, 51, 265–272.
- Agbekodo, K.M., Legube, B., Cote, P., 1996. Organics in NF permeate. *Journal of American Water Works Association*, 88, 5, 67-74.
- Ahmad, R., Amirtharajah, A., 1998. Detachment of particles during biofilter backwashing. *Journal of American Water Works Association*, 90, 12, 74-85.
- Aiken, G., Cotsaris, E., 1995. Soil and hydrology: Their effect on NOM. *Journal of American Water Works Association*, 87, 1, 36-45.
- Aktaş, Ö., Çeçen, F., 2006a. Effect of type of carbon activation on adsorption and its reversibility. *Journal of Chemical Technology and Biotechnology*, 81, 1, 94-101.
- Aktaş, Ö., Çeçen, F., 2006b. Effect of activation type on bioregeneration of various activated carbons loaded with phenol. *Journal of Chemical Technology and Biotechnology*, 81, 7, 1081-1092.
- Amann, R.I., Krumholz, L., Stahl, D.A., 1990. Fluorescent-oligonucleotide probing of whole cells for determinative, phylogenetic, and environmental studies in microbiology. *Journal of Bacteriology*, 172, 762-770.
- Amann, R.I., Ludwig, W., Schleifer, K.H., 1995. Phylogenetic identification and in situ detection of individual microbial cells without cultivation. *Microbiological Reviews*, 59, 143-169.
- Amann, R.I., Snaidr, J., Wagner, M., Ludwig, W., Schleifer, K.H., 1996. In situ visualization of high genetic diversity in a natural bacterial community. *Journal of Bacteriology*, 178, 3496-3500.

Amy, G.L., Kuo, C.J., Sierka, R.A., 1988. Ozonation of humic substances- Effects on molecular weight distributions of organic carbon and trihalomethane formation potential. *Ozone Science and Engineering*, 10, 1, 39-54.

Andersson, A., Laurent, P., Kihn, A., Prevost, M., Servais, P., 2001. Impact of temperature on nitrification in biological activated carbon (BAC) filters used for drinking water treatment. *Water Research*, 35, 12, 2923-2934.

Aoi, Y., Masaki, Y., Tsuneda S., Hirata, A., 2004. Quantitative analysis of *amoA* mRNA expression as a new biomarker of ammonia oxidation activities in a complex microbial community. *Letters of Applied Microbiology*, 39, 477-482.

Araki, N., Yamaguchi, T., Yamazaki, S., Harada, H., 2004. Quantification of *amoA* gene abundance and their *amoA* mRNA levels in activated sludge by real-time PCR. *Water Science and Technology*, 50, 8, 1-8.

Asami, M., Aizawa, T., Morioka, T., Nishijima, W., Tabata, A., Magara, Y., 1999. Bromate removal during transition from new granular activated carbon (GAC) to biological activated carbon (BAC), *Water Research*, 33, 2, 2797-2804.

Atlas, R.M. Bartha, R., 2000. *Microbial Ecology: Fundamentals and Applications*, Fourth Edition, Benjamin/Cummings Publishing Company Inc., Redwood City, CA.

AWWA, 1995. *Problem Organisms in Water: Identification and Treatment*. In *Manual of Water Supply Practices, Manual M7*, Second Ed., of American Water Works Association, Denver, CO.

Bablon, G.P., Ventresque, C., Aim, R.B., 1988. Developing a sand-GAC filter to achieve high-rate biological filtration. *Journal of American Water Works Association*, 80, 47-53.

Beaudet, J.F., Prevost, N., Arcouette, N., Niquette, P., Coallier, J., 1996. Controlling Annelids in Biological Activated Carbon Filters, *Proceedings of of American Water Works Association WQTC*, Boston, MA.

Bej, A.K., DiCesare, J.L., Haff, L., Atlas R.M., 1991a, Detection of *Escherichia coli* and *Shigella spp.* in water by using the polymerase chain reaction and gene probes for uid. *Applied and Environmental Microbiology*, 57, 1013-1017.

Bej, A.K., Mahbubani, M.H., Atlas, R.M., 1991b. Amplification of nucleic acids by polymerase chain reaction (PCR) and other methods and their applications, *Critical Reviews in Biochemistry and Molecular Biology*, 26, 301-334.

Benedek, A., Bancsi, J.J., Malaiyandi, M., Lancaster, E.A., 1979. Effect of ozone on the biological degradation and activated carbon adsorption of natural and synthetic organics in water, Part II: Adsorption. *Ozone Science and Engineering*, 1, 4, 347-356.

Billen, G., Servais, P., Bouillot, P., Ventresque, P., 1992. Functioning of biological filters used in drinking water- The Chabrol Model. *Journal of Water Supply Research Technology – Aqua* 41, 4, 231-241.

Bjelopavlic, M., Newcombe, G., Hayes, R., 1999. Adsorption of NOM onto activated carbon: Effect of surface charge, ionic strength, and pore volume distribution. *Journal of Colloid and Interface Science*, 210, 271-280.

Block, J.C., Haudidier, K., Paquin, J.L., Miazga, J., Levi, Y., 1993. Biofilm accumulation in drinking water distribution systems. *Biofouling*, 6, 333–343.

Boehm, H., 1966. Functional groups on the surfaces of solids. *Angewandte Chemie International Edition*, 5, 6, 533-544.

Boere, J.A., 1991. Reduction of Oxidants by Granular Activated Carbon Filtration. *Proceedings of the Tenth Ozone World Congress, Monaco, 19-21 March 1991.*

Bouillot P., Roustan J.L., Albagnac G. and Cadet J.L., 1992. Biological nitrification kinetics at low temperature in a drinking-water production plant, *Water Supply*, 10, 137-153.

Bouwer, E.J., Crowe, P., 1988. Biological processes in drinking water treatment. *Journal of American Water Works Association*, 80, 9, 82–93.

Bouwer, E.J., Crowe, P.B., 1992. Assessment of biological processes in drinking water treatment. *Journal of of American Water Works Association*, 80, 82–93.

Bouwer, E.J., McCarthy P.L., 1981. Removal of trace chlorinated organic compounds by activated carbon and fixed-film bacteria. *Environmental Science and Technology*, 16, 12, 836-843.

Bremer, P.J., Wells, D.B., 2001. Biocorrosion of copper in potable water. *Journal of American Water Works Association*, 93, 8, 82–91.

Britschgi, T.B., Giovannoni, S.J., 1991. Phylogenetic analysis of a natural marine bacterioplankton population by rRNA gene cloning and sequencing. *Applied and Environmental Microbiology*, 57, 1707-1713.

Byrene, J.F., Marsh, H., 1995. Introductory Overview. In: Patrick, J.W. (Ed.), *Porosity in Carbons*. 1-49, Halsted Pres, NY.

Cable, C.J., Jones, R.G., 1996. Assessing the Effectiveness of Ozonation Followed by Slow Sand Filtration in Removing THM Precursor Material from an Upland Raw Water. In Graham, N., Collins R. (Eds.), *Advances in Slow Sand And Alternative Biological Filtration*, 29-37, John Wiley & Sons, Chichester.

Camel, V., Bermond, A., 1998. The use of ozone and associated oxidation processes in drinking water treatment. *Water Research*, 32, 3208-3222.

Carlson, G., Silverstein, J., 1997. Effect of ozonation on sorption of natural organic matter by biofilm. *Water Research*, 31, 10, 2467-2478.

Carlson, G., Silverstein, J., 1998. Effect of molecular size and charge on biofilm sorption of organic matter. *Water Research*, 32, 5, 1580-1592.

Carlson, K.H., Amy, G., 1997. The formation of filter removable biodegradable organic matter during ozonation. *Ozone Science and Engineering*, 19, 2, 179-199.

Carlson, K.H., Amy, G.L., 1998. BOM removal during biofiltration. *Journal of American Water Works Association*, 90, 12, 42-52.

Carlson, K.H., Amy, G., 2001. Ozone and biofiltration optimization for multiple objectives. *Journal of American Water Works Association*, 93, 1, 88-98.

Chaiket, T., Singer, P.C., Miles, A., Moran, M., Pallota, C., 2002. Effectiveness of coagulation, ozonation and biofiltration in controlling DBPs. *Journal of American Water Works Association*, 84, 12, 81-95.

Chang, H.T., Rittmann, B.E., 1987. Mathematical modeling of biofilm on activated carbon. *Environmental Science and Technology*, 21, 3, 273-285.

Characklis, W.G., Marshall, K.C., 1990. *Biofilms*, Wiley Interscience, John Wiley and Sons, Toronto.

Cho, M., Kim, H., Soon, H., Yoon, J., 2003. Investigation of ozone reaction in river waters causing instantaneous ozone demand. *Ozone: Science and Engineering*, 25, 4, 251-259.

Chudyk, W.A., Snoeyink, V.L., 1984. Bioregeneration of activated carbon saturated with phenol. *Environmental Science and Technology*, 18, 1, 1-5.

Cleasby, J.L., 1990. Filtration. In: Pontius, F.W. (Ed.), *Water Quality and Treatment*, McGraw Hill, NY.

Collins, M. R., Amy, G. L., Steelink, C., 1986. Molecular weight distribution, carboxylic acidity and humic substances content of aquatic organic matter: Implications for removal during water treatment. *Environmental Science and Technology*, 20, 1028-1032.

Cydzik-Kwiatkowska, A., Ciesielski, S., Wojnowska-Baryla, I., 2007. Bacterial *amoA* and 16S rRNA genes expression in activated sludge during aeration phase in sequencing batch reactor. *Polish Journal of Natural Science*, 22, 2, 246-255.

Çeçen, F., 1993. Adsorption characteristics of a biotreated pulp mill effluent. *Water Science and Technology*, 28, 2, 1–10.

Çeçen, F., Aktaş, Ö., 2001. Powdered activated carbon-assisted biotreatment of a chemical synthesis wastewater. *Journal of Chemical Technology and Biotechnology*, 76, 1249-1259.

Çorapcioglu, M.O., Huang, C.P., 1987. The surface acidity and characterization of some commercial activated carbons, *Carbon* 25, 4, 569–578.

Daims, H., Nielsen, P.H., Nielsen, J.L., Juretschko, S., Wagner, M., 2000. Novel *Nitrospira*-like bacteria as dominant nitrite-oxidizers in biofilms from wastewater treatment plants: Diversity and in situ physiology. *Water Science and Technology*, 41, 85-90.

Daims, H., Nielsen, J.L., Nielsen, P.H., Schleifer, K.H., Wagner, M., 2001. In situ characterization of *Nitrospira*-like nitrite-oxidizing bacteria active in wastewater treatment plants. *Applied and Environmental Microbiology*, 67, 5273-5284.

Dalmacija, B., Tamas, Z., Miskovik, D., Karlovic, E., Petrovic, O., 1992. The biosorption of selected pesticides from waters by biologically activated carbon. *Water Science and Technology*, 26, 1991-1994.

de Beer, D., Stoodley, P., Roe, F., Lewandowski, Z., 1993. Effects of biofilm structure on oxygen distribution and mass transport. *Biotechnology and Bioengineering*, 43, 1131-1138
Denver, CO: American Water Works Association.

DeLong, E.F., Franks, D.G., Alldredge, A.L., 1993, Phylogenetic diversity of aggregate-attached vs. free-living marine bacterial assemblages. *Limnology and Oceanography*, 38, 924-934.

Derbyshire, F., Jagtoyen, M., Thwaites, M., 1995. Activated Carbons- Production and Application. In: Patrick, J.W. (Ed.), Porosity in Carbons, 227-252, Halsted Pres, New York.

Devlet Su İşleri (DSİ) Home page, <http://www.dsi.gov.tr/baraj/detay.cfm?BarajID=48>. (accessed April 2008).

DeWaters, J.E., Digiano, F.A., 1990. Influence of ozonated natural organic matter on the biodegradation of a micropollutant in a GAC bed. Journal of American Water Works Association, 82, 8, 69-80.

Diehl, A.C., Speitel Jr., G.E., Symons, J.M., Krasner, S.W., Hwang, C.J., Barrett, S.E., 2000. DBP formation during chlorination. Journal of American Water Works Association, 92, 6, 76-90.

Dionisi, H.M., Layton, A.C., Harms, G., Gregory, I.R., Robinson, K.G., Sayler, G.S., 2002. Quantification of *Nitrosomonas* oligotropha-like ammonia-oxidizing bacteria and *Nitrospira* spp. from full-scale wastewater treatment plants by competitive PCR. Applied and Environmental Microbiology, 68, 245-253.

Dovantzis, K., 1986. A Mathematical Model of the Interaction Between the Adsorption and Biodegradation on Granular Activated Carbon at Low Substrate Concentrations. PhD Dissertation, University of North Caroline at Chapel Hill, USA.

EC 80/779, 1980. Directive of July 1980 relating to the quality of water intended for human consumption. Official Journal of European Community, 23, 11-29.

Edzwald, J.K., 1994. Coagulation Concepts for Removal of TOC. American Water Works Association WQTC Conference, San Fransisco, 6-10 November 1994.

Edzwald, J.K., Tobiason, J.E., 1999. Enhanced Coagulation: US requirements and a broader view. Water Science and Technology, 40, 9, 63-70.

Escobar, I.C., Randall, A.A., 2001. Assimilable organic carbon (AOC) and biodegradable dissolved organic carbon (BDOC): Complementary measurements. *Water Research*, 35, 18, 4444-4454.

Ficker, M., Krastel, K., Orlicky, S., Edwards, E., 1999. Molecular characterization of a toluene-degrading methanogenic consortium. *Applied and Environmental Microbiology*, 65, 5576-5585.

Findlay, R.H., King, G.M., Watling, L., 1989. Efficacy of phospholipid analysis in determining microbial biomass in sediments. *Applied and Environmental Microbiology*, 55, 11, 2888-2893.

Fleming, K.K., Harrington, G.W., Noguera, D.R., 2005. Nitrification potential curves: a new strategy for nitrification prevention. *Journal of American Water Works Association*, 97, 8, 90-99.

Frias, J., Ribas, F., Lucena, F., 1992. A method for the measurement of biodegradable organic carbon in waters. *Water Research*, 35, 4444-4454.

Fry, J.C., .1988. Determination of Biomass. In: B. Austin *Methods in Aquatic Bacteriology*, 27-72, Wiley, New York.

Geets, J., Cooman, M., Wittebolle, L., Heylen, K., Vanparrys, B., Vos, P., Verstraete, W., Boon, N., 2007. Real-time PCR assay for the simultaneous quantification of nitrifying and denitrifying bacteria in activated sludge. *Applied Microbiology and Biotechnology*, 75, 211-221.

Giovannoni, S.J., DeLong, E.F., Olsen, G.J., Pace, N. R., 1988. Phylogenetic group-specific oligodeoxynucleotide probes for identification of single microbial cells. *Journal of Bacteriology*, 170, 720-726.

Glaze, W.H., 1982. Pilot-scale evaluation of biological activated carbon for the removal of THM precursors. EPA-600/S2-82-046, Environmental Protection Agency.

Glaze, W.H., 1990. Group Report: "What is the Composition of Organic Acids in Aquatic Ecosystems and How They are Characterized?", In E.M. Perdue and E.T. Gjessing (Eds.) *Organic Acids in Aquatic Ecosystems*, 75-95, John Wiley & Sons, NY.

Goeddertz, J.G., Matsumoto, M.R., Weber, A.S., 1988. Offline bioregeneration of granular activated carbon. *Journal of Environmental Engineering*, 114, 5, 1063-1076.

Gould, M.H., Cameron, D.A., Zabel, T.F., 1984. An experimental study of ozonation followed by slow sand filtration for the removal of humic colour from water. *Ozone Science and Engineering*, 6, 3-15.

Grabinska, A., Perchue, M., Kowalska, T.K., 2004. Biocenosis of BACs used for groundwater treatment. *Water Research*, 38, 1695-1706.

Graham, N.J.D., 1999. Removal of humic substances by oxidation/ biofiltration processes- A review. *Water Science and Technology*, 40, 9, 141-148.

Grens, B.K., Werth, C.J., 2001, Durability of wood-based versus coal-based GAC. *Journal of American Water Works Association*, 93, 4, 175-181.

Gürol, M.D., 1985. Factors controlling the removal of organic pollutants in ozone reactors. *Journal of American Water Works Association*, 778, 55-60.

Haag, W.R., Hoigne, J., Bader, H., 1984. Improved ammonia oxidation by ozone in the presence of bromide ion during water treatment. *Water Research*, 18, 9, 1125-1128.

Hambusch, B., Schmiedel, U., Werner, P., Frimmel, F.H., 1993. Investigations on the biodegradability of fulvic acids. *Acta Hydrochemica Hydrobiologia*, 21, 167-173.

Harms, G., Layton, A.C., Dionisi, H.M., Gregory, I.R., Garrett, V.M., Hawkins, S.A., Robinson, K.G., Sayler, G.S., 2003. Real-time PCR quantification of nitrifying bacteria in a municipal wastewater treatment plant. *Environmental Science and Technology*, 37, 343-351.

Head, I.M., Saunders, J.R., Pickup, R.W., 1998. Microbial evolution, diversity, and ecology: a decade of ribosomal RNA analysis of uncultivated microorganisms. *Microbial Ecology*, 35, 1-21.

Hermansson, A. and Lindgren, P.E., 2001. Quantification of ammonia-oxidizing bacteria in arable soil by real-time PCR. *Applied and Environmental Microbiology*, 67, 972-976.

Hozalski, R.M., Goel, S., Bouwer, E.J., 1992. Use of biofiltration for removal of natural organic matter to achieve biologically stable drinking water. *Water Science and Technology*, 26, 2011-2014.

Hozalski, R.M., Goel, S., Bouwer, E.J., 1995. TOC removal in biologically active sand filters: Effect of NOM source and EBCT. *Journal of American Water Works Association*, 87, 12, 40-54.

Hozalski, R.M., Bouwer, E.J., 1998. Deposition and retention of bacteria in backwashed filters. *Journal of American Water Works Association*, 90, 71-85.

Hozalski, R.M., Bouwer, E.J., Goel, S., 1999. Removal of natural organic matter (NOM) from drinking water supplies by ozone-biofiltration. *Water Science and Technology*, 40, 9, 157-163.

Hozalski, R. W., Bouwer, E. J., 2000. Non-steady simulation of BOM removal in drinking water biofilters: Model development. *Water Research*, 35, 1, 198-210.

Huck, P.M., 1990. Measurement of biodegradable organic matter and bacterial growth in drinking water. *Journal of American Water Works Association*, 82, 7, 78-89.

Huck, P.M., Zhang, S., Price, M.L., 1994. BOM removal during biological treatment: A first order model. *Journal of American Water Works Association*, 86, 6, 61-74.

Huck, P.M., Finch, G.R., Hrudey, S.E., Pepler, M.S., Amirtharajah, A., Bouwer, E.J., Albritton, W.L., Gammie, L., 1997. *Design of Biological Processes for Organics Control*.

Submitted to American Water Works Association Research Foundation, Report No. 90722. Denver, Colorado.

Hutchinson, D.W., Robinson, C.W., 1990. A microbial regeneration process for granular activated carbon- I. Process modelling. *Water Research*, 24, 10, 1209-1215.

Jacangelo, J.G., 1995. Selected processes for removing NOM: An overview. *Journal of American Water Works Association*, 87, 1, 64-78.

Jianlong, W., Ning, Y., 2004. Partial nitrification under limited dissolved oxygen conditions. *Process Biochemistry*, 39, 1223-1229.

Jonge, R.J. de, Breure, A.M., Andel, J.G. van, 1996. Bioregeneration of powdered activated carbon (PAC) loaded with aromatic compounds. *Water Research*, 30, 875–882.

Joret, J.C., Levi, Y., Dupin, T., Gilbert, M., 1988. Rapid Method for Estimating Bioeliminable Organic Carbon in Water. *Proceedings of the of American Water Works Association Annual Conference*, 1715-1725.

Joret, J.C., Levi, Y., Volk, C., 1991. Biodegradable dissolved organic carbon (BDOC) content of drinking water and potential regrowth of bacteria. *Water Science and Technology*, 2, 95–101.

Juretschko, S., Timmermann, G., Schmid, M., Schleifer, K.H., Pommerening-Roser, A., Koops, H.P., Wagner, M., 1998. Combined molecular and conventional analyses of nitrifying bacterium diversity in activated sludge: *Nitrosococcus mobilis* and *Nitrospira-like bacteria* as dominant populations. *Applied and Environmental Microbiology*, 64, 3042-3051.

Kaastrup E., Halmo T.M., 1989. Removal of Aquatic Humus by Ozonation and Activated-Carbon Adsorption. In Suffet I., MacCarthy, H. (Eds.), *Aquatic Humic Substances, Influence on Fate and Treatment of Pollutants*, 697–726, American Chemical Society, Washington, DC.

Kameya, T., Hada, T., Urano, K., 1997. Changes of adsorption capacity and pore distribution of biological activated carbon on advanced water treatment, *Water Science and Technology*, 35, 7, 155-162.

Kane, M.D., Poulsen, L.K., Stahl, D.A., 1993, Monitoring the enrichment and isolation of sulfate-reducing bacteria by using oligonucleotide hybridization probes designed from environmentally derived 16S rRNA sequences. *Applied and Environmental Microbiology*, 59, 682-686.

Kaplan, L.A., Reasoner, D.J., Rice, E.W., 1994. A Survey of BOM in US drinking waters. *Journal of American Water Works Association*, 86, 2, 121-132.

Karanfil, T., Erdoğan, İ., Schlautman, M. A., 2003. Selecting filter membranes for measuring DOC and UV₂₅₄. *Journal of American Water Works Association*, 95, 3, 86-100.

Karanfil, T., Dastgheib, S., 2004. Trichloroethylene adsorption by fibrous and granular activated carbons: Aqueous phase, gas phase, and water vapor adsorption studies. *Environmental Science and Technology*. 38, 5834-5841.

Khan, E., Babcock, R.W., Suffet, I.H., Stenstrom, M.K., 1998. Method development for measuring biodegradable organic carbon in reclaimed and effluent. *Water Environment Research*, 70, 5, 1025–1032.

Kihn, A., Laurent, P., Servais, P., 2000. Measurement of potential activity of fixed nitrifying bacteria in biological filters used for drinking water production. *Journal of Industrial Microbiology and Biotechnology*, 24, 161-166.

Kihn A., Andersson A., Laurent P., Servais P. and Prévost M., 2002. Impact of filtration material on nitrification in biological filters used in drinking water production. *Journal of Water SRT-Aqua*, 51, 35-46.

Kim, D.J., Miyahara, T., Nioke, T., 1997a. Effect of C/N Ratio on the bioregeneration of biological activated carbon. *Water Science and Technology*, 36, 12, 239-249.

Kim, W.H., Nishijima, W., Shoto, E., Okada, M., 1997b. Competitive removal of biodegradable dissolved organic carbon in ozonation-biological activated carbon. *Water Science and Technology*, 35, 147-153.

Kim, S.H. Pirbazari, M., 1989. Bioactive Adsorber Model for Industrial Wastewater Treatment. *Journal of Environmental Engineering*, 115, 6, 1235-1256.

Kitis, M., 2001. Probing Chlorine Reactivity of Dissolved Organic Matter for Disinfection By-Product (DBP) Formation: Relations with Specific Ultraviolet Absorbance (SUVA) and Development of the DBP Reactivity Profile. PhD Dissertation, Clemson University, USA.

Krasner, S.W., Schlimenti, M.J., Coffey, B.M., 1993. Testing biologically active filters for removing aldehydes formed during ozonation. *Journal of American Water Works Association*, 85, 5, 62-73.

Krasner, S.W., Croue, J.P., Buffle, J., Perdue, E.M., 1996. Three approaches for characterizing NOM. *Journal of American Water Works Association*, 88, 6, 66-79.

Kumar, S., Tamura, K., Jakobsen, I.B., Nei, M., 2001. MEGA2: molecular evolutionary genetics analysis software. *Bioinformatics*, 17, 1244-1245.

Langlais, B., Reckhow, D.A., Brink, D.R., 1991. *Ozone in Water Treatment: Application and Engineering*. American Water Works Association Research Foundation and Lewis Publishers, Denver, 227.

Laurent, P., Prevost, M., Cigana, J., Niquette, P., Servais, P., 1998. Biodegradable organic matter removal in biological filters: Evaluation of the CHABROL model. *Water Research*, 33, 6, 1387-1398.

Lawrence, J., 1980. Semi-quantitative determination of fulvic acid, tannin and lignin in natural waters. *Water Research*, 14, 4, 373-377.

LeChevallier, M.W., 1990. Coliform regrowth in drinking water: A review. *Journal of American Water Works Association*, 82, 11, 74-86.

LeChevallier, M.W., Becker, W.C., Schorr, P., Lee, R.G., 1992. Evaluating the performance of biologically active rapid sand filters. *Journal of American Water Works Association*, 84, 4, 136-146.

LeChevallier, M.W., Welch, N.W., Smith, D.B., 1996. Full-scale studies of factors related to coliform regrowth in drinking water. *Applied and Environmental Microbiology*, 62, 7, 2201-2212.

Lee, S.H., O'Connor, J.T., Banerji, S.K., 1980. Biologically mediated corrosion and its effects on water quality in distribution systems. *Journal of American Water Works Association*, 72, 11, 636-645.

Levy, R.V., Hart, F.L., Cheetham, R.D., 1986. Occurrence and public significance of invertebrates in drinking water systems. *Journal of American Water Works Association*, 78, 9, 105-116.

Li, X, Chu, H.P., 2003, Membrane bioreactor for the drinking water treatment of polluted surface supplies. *Water Research*, 37, 4781-4791.

Li, L., Zhu, W., Zhang, P., Zhang, Q., Zhang, Z., 2006. AC/O₃-BAC processes for removing refractory and hazardous pollutants in raw water. *Journal of Hazardous Materials*, 2006, 129-133.

Liao, W., Christman, R.F., Johnson, J.D., Millington, D.S., 1982. Structural characterization of aquatic humic material. *Environmental Science and Technology*, 16, 7, 403-410.

Lipponen, M.T.T., Martikainen, P.J., Vasara, R.E., Servomaa, K., Zacheus, O., Kontro, M.H., 2004. Occurrence of nitrifiers and diversity of ammonia-oxidizing bacteria in developing drinking water biofilms. *Water Research*, 38, 4424-4434.

Lipponen, M.T.T., Suutaria, M.H., Martikainen, P.J., 2002. Occurrence of nitrifying bacteria and nitrification in Finnish drinking water distribution systems. *Water Research*, 36, 4319–4329.

Liu, X., 2001. Drinking Water Biofiltration: Assessing Key Factors and Improving Process Evaluation. Ph. D. Dissertation, University of Waterloo, Ontario, CA.

Liu, X., Huck, P.M., Slawson, R.M., 2001. Factors affecting drinking water biofiltration. *Journal of American Water Works Association*, 93, 12, 90-101.

Liu, X., Slawson, R.M., 2001. Factors affecting drinking water biofiltration. *Journal of American Water Works Association* 93, 12, 90–101.

Lu, P., Huck, P.M., 1993. Evaluation of Methods for Measuring Biomass and Biofilm Thickness in Biological Drinking Water Treatment, Proceedings of of American Water Works Association WQTC, Miami, FL.

Malley, J.P., Eighmy, T.T., Collins, M.R., Royce, J.A., Morgan, D.F., 1993. The performance and microbiology of ozone-enhanced biological filtration. *Journal of American Water Works Association*, 85, 12, 47-57.

Manem, J.A., Rittmann, B.E., 1992. Effects of fluctuations in biodegradable organic matter on nitrification filters. *Journal of American Water Works Association*. 84, 4, 147–151.

Manz, W., Amann, R., Ludwig, W., Wagner, M., Schleifer, K.H., 1992. Phylogenetic oligodeoxynucleotide probes for the major subclasses of *Proteobacteria*: Problems and solutions. *Systematic and Applied Microbiology*, 15, 593-600.

McDowell, W.H., Zsolnay, A., Aitkenhead-Peterson, J.A., Gregorich, E.G., Jones, D.L., Jödemann, D., Kalbitz, K., Marschner, B., Schwesig, D., 2006. A comparison of methods to determine the biodegradable dissolved organic carbon from different terrestrial sources. *Soil Biology and Biochemistry*, 38, 1933-1942.

Meijers, A.P., 1977. Quality aspects of ozonisation. *Water Research*, 11, 647-652.

Mellanby, J.F., 1991. Oxidation of Colored Water with Ozone Before Slow Sand Filtration. Proceedings of the Slow Sand Filtration Workshop, Durham, New Hampshire, October 27-30, Denver, American Water Works Association.

Merlet, N., 1992. Enlèvement de la matière organique dans les filters CAB. *Revue des Sciences de l'Eau*. 5, 143-153.

Mertoglu, B., Calli, B., Inanc, B., Ozturk, I., 2005. Comparative analysis of nitrifying bacteria in full scale oxidation ditch and aerated nitrification biofilter by using FISH and DGGE. *Journal of Environmental Science and Health. Part A*, 40, 5, 937-948.

Mertoglu, B., Calli, B., Inanc, B., Ozturk, I., 2006. Evaluation of in situ ammonia removal in an aerated landfill bioreactor. *Process Biochemistry*, 41, 12, 2359-2366.

Metcalf & Eddy, 2003. *Wastewater Engineering, Treatment and Reuse*, Fourth ed., McGraw-Hill, N.Y.

Miladinovic, N., Weatherley, L.R., 2008. Intensification of ammonia removal in a combined ion-exchange and nitrification column. *Chemical Engineering Journal*, 135, 15-24.

Miltner, R.J., Summers, R.S., Wang, J., Swertfeger, J., Rice, E., 1992. The Response of Biological Filters to Backwashing. of American Water Works Association-WQTC Proceedings, Toronto, Canada.

Miltner, R.J., Summers, R.S., Wang, J.Z., 1995. Biofiltration Performance: Part II, Effect of backwashing. *Journal of American Water Works Association*, 87, 12, 64-70.

Mobarry, B.K., Wagner, M., Urbain, V., Rittmann, B.E., Stahl, D.A., 1996. Phylogenetic probes for analyzing abundance and spatial organization of nitrifying bacteria. *Applied and Environmental Microbiology*, 62, 2156-2162.

Mochhidzuki, K., Takeuchi, Y., 1999. The effects of some inhibitory components on biological activated carbon. *Water Research*, 33, 11, 2609-2616.

Moll, D.M., Summers, R.S., Fonseca, A.C., Matheis, W., 1999. Impact of temperature on drinking water biofilter performance and microbial community structure. *Environmental Science and Technology*, 33, 2377-2382.

Moore, B.C., 2000. Factors Controlling the Adsorption of Natural Organic Matter onto Virgin and Thermally Reactivated Granular Activated Carbons during Full Scale Water Treatment. PhD Dissertation, Pennsylvania State University, USA.

Morgan, J.W., Forster, C.F., Evinson, L., 1990. Molecular size distribution of dissolved organic matter. *Journal of Environmental Engineering*, 116, 1046-1062.

Morris, G., Newcombe, G., 1993. Granular Activated Carbon: The variation of surface properties with the adsorption of humic substances. *Journal of Colloid and Interface Science*, 159, 413-420.

Mousset, B.M, Croue, J.P., Lefebvre, E., Legube, B., 1997. Distribution and characterization of dissolved organic matter of surface waters. *Water Research*, 31, 3, 541-553.

Muyzer, G., Smalla, K., 1998. Application of denaturing gradient gel electrophoresis (DGGE) and temperature gradient gel electrophoresis (TGGE) in microbial ecology. *Antonie Van Leeuwenhoek*, 73, 1, 127-141.

National Center for Biotechnology Information, www.ncbi.nlm.nih.gov. (Accessed May, 2008).

Newcombe, G., 1994. Activated carbon and soluble humic substances: Adsorption, Desorption and Surface Charge Effects. *Journal of Colloid and Interface Science*, 164, 452-462.

- Newcombe, G., Donati, C., Drikas, M., Hayes, R., 1994. Adsorption onto activated carbon: Electrostatic and non-electrostatic interactions. *Water Supply*, 14, 129-144.
- Newcombe, G., Drikas, M., 1997. Adsorption of NOM onto activated carbon: Electrostatic and nonelectrostatic effects. *Carbon* 35, 9, 1239-1250.
- Newcombe, G., Hayes, R., Drikas, M., 1993. Granular activated carbon: Importance of surface properties in the adsorption of naturally occurring organics. *Colloids and Surfaces A: Physicochemical and Engineering Aspects*, 78, 65-71.
- Newcombe, G., Drikas, M., Assemi, S., Beckett, R., 1997. The influence of characterised natural organic material on activated carbon adsorption: I. Characterisation of concentrated reservoir water. *Water Research*, 31, 5, 963
- Nicolaisen, M. H., Ramsing, N.B., 2002. Denaturing gradient gel electrophoresis (DGGE) approaches to study the diversity of ammonia-oxidizing bacteria. *Journal of Microbiological Methods*, 50, 189-203.
- Niquette, P., Prevost, M., MacLean, R.G., Thibault, D., Coallier, J., Desjardins, R., Lafrance, P., 1998. Backwashing first stage sand-BAC filters. Does it increase removal of biodegradable organic matter and ammonia? *Journal of American Water Works Association*, 90, 1, 86-97.
- Nishijima, W., Kim, W.H., Shoto, E., Okada, M., 1998. The performance of an ozonation-biological activated carbon process under long term operation. *Water Science and Technology*, 38, 6, 163-169.
- Nishijima, W., Speitel, G.E., 2004. Fate of biodegradable dissolved organic carbon produced by ozonation on biological activated carbon. *Chemosphere*, 56, 113-119.
- Norit Carbon Corporation, 2002. *Biological Activated Carbon Filtration*.

Novak, J.M., Mills, G.L., Bertsch, P.M., 1992. Estimating the percent aromatic carbon in soil and aquatic humic substances using ultraviolet absorbance spectroscopy. *Journal of Environmental Quality*, 21, 1, 144-147.

Nübel, U., Engelen, B., Felske, A., Snaidr, J., Wieshuber, A., Amann, R.I., Ludwig, W., Backhaus, H., 1996. Sequence heterogeneities of genes encoding 16S rRNAs in *Paenibacillus polymyxa* detected by temperature gradient gel electrophoresis. *Journal of Bacteriology*, 178, 5636-5643.

Odegaard, H., 1996. The Development of an Ozonation / Biofiltration Process for the Removal of Humic Substances. In Graham, N., Collins, R. (Eds.), *Advances in Slow Sand and Alternative Biological Filtration*, 39-49, John Wiley & Sons, Chichester.

Odell, L.H., Kirmeyer, G.J., Wilczak, A., Jacangelo, J.G., Marcinko, J.P., Wolfe, R.L., 1996. Controlling nitrification in chloraminated systems. *Journal of American Water Works Association*, 88, 7, 86-98.

Okabe, S., Satoh, H., Watanabe, Y., 1999. In situ analysis of nitrifying biofilms as determined by in situ hybridization and the use of microelectrodes. *Applied and Environmental Microbiology*, 65, 3182-3191.

Okano, Y., Hristova, K.R., Leutenegger, C.M., Jackson, L.E., Denison, R.F., Gebreyesus, B., Lebauer, D., Scow, K.M., 2004. Application of real-time PCR to study effects of ammonium on population size of ammonia-oxidizing bacteria in soil. *Applied and Environmental Microbiology*, 70, 1008-1016.

Olmstead, K.P., Weber, W.J. Jr., 1991. Interactions Between Microorganisms and Activated Carbon in Water and Wastewater Treatment Operations. *Chemical Engineering Communications*, 108, 113-125.

Owen, D.M., Amy, G.L., Chowdhury, Z.K., Paode, R., McCoy, G., Viscosi, K., 1995. NOM- Characterization and treatability. *Journal of American Water Works Association*, 87, 1, 46-65.

Park, S.K., Pak, K.R., Choi, S.C., Kim, Y.K., 2004. Evaluation of bioassays for analyzing biodegradable dissolved organic carbon in drinking water. *Journal of Environmental Science and Health Part A—Toxic/Hazardous Substances and Environmental Engineering*, A39, 103–112.

Payment, P., Richardson, L., Siernatycki, J., Dewar, R., Edwardes, M. Franco, E., 1991. A randomized trial to evaluate the risk of gastro-intestinal disease due to consumption of drinking water meeting current micro-biological standards. *American Journal of Public Health*, 81, 703-708.

Petersen, N.R., Nicolaisen, M.H., Revsbech, N.P., Lomstein, B.A., 2004. Competition between ammonia-oxidizing bacteria and benthic microalgae. *Applied and Environmental Microbiology*, 70, 5528-5537.

Pontius, F.W., 1999. Regulations of Disinfection Byproducts, In: Singer, P.C., (Ed.) *Formation and Control of Disinfection By-products in Drinking Water*. 139-159, American Water Works Association, Denver.

Prévost M., Desjardins R., Lafrance P., Duchesne D. and Coallier J., 1992. Optimization of biological activated carbon filtration of drinking water: effect of filtration velocity, ozone dosage and position and of carbon type. In: *Proceedings of the Fifth National Conference on Drinking Water- of American Water Works Association*. Research Foundation, Winnipeg, Canada, 63-77.

Queinnec, I., Ochoa, J.C., Wouwer, A.V., Paul, E., 2006. Development and calibration of a nitrification PDe model based on experimental data issued fro biofilter treating drinking water. *Biotechnology and Bioengineering*, 94, 2, 209-222.

Randtke, S.J., 1988. Organic contaminant removal by coagulation and related process configurations. *Journal of American Water Works Association*, 80, 5, 40-56.

Raskin, L., Poulsen, L.R., Noguera, D.R., Rittman, B.E., Stahl, D.A., 1994. Quantification of methanogenic groups in anaerobic biological reactors by oligonucleotide probe hybridization. *Applied and Environmental Microbiology*, 60, 1241-1248.

Reckhow, D.A., Xie, Y., McEnroe, R., Byrnes, P., Tobiason, J.E., Switzenbaum, M.S., (1993). The Use of Chemical Surrogates for Assimilable Organic Carbon, Proceedings of American Water Works Association Annual Conference, San Antonio.

Ririe, K.M., Rasmussen, R.P., Wittwer, C.T., 1997. Product differentiation by analysis of DNA melting curves during the polymerase chain reaction, *Analytical Biochemistry*, 245, 154-160.

Rittmann, B.E., Snoeyink, V.L., 1984. Achieving biologically stable drinking water. *Journal of American Water Works Association*, 76, 10, 106-114.

Rittmann, B.E., Huck, P.M., 1989. Biological treatment of public water supplies. *CRC Critical Reviews in Environmental Control*, 19, 2, 119-184.

Robinson, K.G, Dionisi, H.M., Harms, G., Layton, A.C., Gregory, I.R., Sayler, G.S., 2003. Molecular assessment of ammonia- and nitrite-oxidizing bacteria in full-scale activated sludge wastewater treatment plants. *Water Science and Technology*, 48, 8, 119-126.

Roche, P., Volk, C., Carnonnier, F., and Paillard, H., 1994. Water oxidation by or ozone / hydrogen peroxide using the ozotest or peroxotest methods. *Ozone Science and Engineering* 16, 135-155.

Rodríguez-Reinoso, F., 1997. Introduction to Carbon Technologies. In Marsh, H., Heintz, E.A., Rodríguez-Reinoso, F. (Eds.), 35-101, Printer of the University of Alicante, Alicante, Spain:

Rotthauwe, J.H., Witzel, K.P., Liesack, W., 1997. The ammonia monooxygenase structural gene *amoA* as a functional marker: molecular fine-scale analysis of natural ammonia-oxidizing populations. *Applied and Environmental Microbiology*, 63, 4704-4712.

Rusten, B., Eikebroek, B., Ulgenes, Y., Lygren, E., 2006. Design and operations of the Kaldnes moving bed bioreactors, *Aquaculture Engineering*, 34, 322-331.

Sanguinetti, C.J., Dias Neto, E., Simpson, A.J., 1994. Rapid silver staining and recovery of PCR products separated on polyacrylamide gels. *Biotechniques*, 17, 914-921.

Schramm, A., de Beer, D., van den Heuvel, J.C., Ottengraf, S., Amann, R., 1999. Microscale distribution of populations and activities of *Nitrosospira* and *Nitrospira spp.* along a macroscale gradient in a nitrifying bioreactor: quantification by in situ hybridization and the use of microsensors. *Applied and Environmental Microbiology*, 65, 3690-3696.

Schramm A, de Beer D, Gieseke A, Amann R. Microenvironments and distribution of nitrifying bacteria in a membrane-bound biofilm. *Environmental Microbiology*, 2000, 2, 680-686.

Schultz, J.R., Keinath, T.M., 1984. Powdered activated carbon treatment process mechanisms. *Journal of Water Pollution Control Federation*, 56, 143-151.

Seger, A., Rothman, M., 1996. Slow Sand Filtration with and without Ozonation in Nordic Climate. In Graham, N., Collins, R. (Eds.), *Advances in Slow Sand and Alternative Biological Filtration*, 119-128, John Wiley & Sons, Chichester.

Seredynska-Sobecka, B., Tomaszewska, M., Janus, M., Morawski, A.W., 2006. Biological activation of carbon filters. *Water Research*, 40, 355-363.

Servais, P., Billen, G., Hascoet, M.C., 1987. Determination of the biodegradable fraction of dissolved organic matter. *Water Research*, 21, 445-450.

Servais, P.G., Bilen, G., Ventresque, C., Bablon, G.P., 1991. Microbial activity in GAC filters at the Choisy-le-Roi treatment plant. *Journal of American Water Works Association*, 83, 2, 62-68

Servais, P., Billen, G., Bouillot, P., Benezet, M., 1992. A pilot study of biological GAC filtration in drinking water treatment. *Aqua* 41, 3, 163-168.

Servais P., Billen G., Laurent P., Levi Y., Randon, G., 1993. Bacterial regrowth in distribution systems. Proceedings of American Water Works Association WQTC Conference, Miami, FL, 7–10 November, 1993.

Sholz, M., Martin, R.J., 1997. Ecological equilibrium on biological activated carbon. *Water Research*, 31, 2, 2959-2968.

Shukairy, H.M., Summers, R.S., Miltner, R.J., 1992. The impact of ozonation and biological treatment on disinfection by-products. Proceedings, 4th Drinking Water Workshop, Government of Quebec, Montreal, Canada, November.

Shukairy, H.M., Miltner, R.J., Summers, R.S., 1994. Bromides effect on DBP formation, speciation and control. I. Ozonation, *Journal of American Water Works Association*, 86, 6, 72-87.

Sing, K.S.W., 1985. Reporting physisorption data for gas/solid systems. *Pure Applied Chemistry*, 57, 4, 603-619.

Snoeyink, V. L., 1990. Adsorption of Organic Compounds. In F.W. Pontius (Ed.), *Water Quality and Treatment*, Fourth Edition, 781, McGraw-Hill Inc, NY.

Snoeyink, V. L., Summers, R.S., 1999. Adsorption of Organic Compounds. In F.W. Pontius (Ed.), *Water Quality and Treatment*, Fifth Edition, McGraw-Hill Inc, NY.

Sontheimer, H., Crittenden, J., Summers, R.S., 1988. *Activated Carbon for Water Treatment*. Second Edition, Forschungstelle Engler – Bunte- Institute, Universität Karlsruhe, Karlsruhe, Germany.

Sontheimer, H., Frick, B.R., Fettig, J., Hörner, G., Hubele, C., Zimmer, G., 1985. Adsorptionsverhalten zur Wasserreinigung. DVGW-Forschungsstelle am Engler-Bunte-Institut der Universität Karlsruhe (TH).

Speitel, G.E. Jr., Dovantzis, K., DiGiano, F.A., 1987. Mathematical modeling of bioregeneration in GAC columns. *Journal of Environmental Engineering*, 113, 1, 32-48.

Speitel Jr, G.E., DiGiano, F.A., 1987. Biofilm shearing under dynamic conditions. *Journal of Environmental Engineering*, 113, 3, 464-475.

Stahl, D.A., Flesher, B., Mansfield, H.R., Montgomery, L., 1988. Use of phylogenetically based hybridization probes for studies of ruminal microbial ecology. *Applied and Environmental Microbiology*, 54, 1079-1084.

Staley, J.T., Konopka, A., 1985. Measurement of in situ activities of nonphotosynthetic microorganisms in aquatic and terrestrial habitats. *Annual Review of Microbiology*, 39, 321-346.

Steinberg, C., Muenster, U., 1985. Geochemistry and Ecological Role of Humic Substances in Lakewater, In: *Humic Substances in Soil, Sediment, and Water: Geochemistry, Isolation and Characterization*, eds., G. R. Aiken, D. M. McKnight, R. L. Wershaw, and P. MacCarthy, 105-145, John Wiley & Sons, NY.

Storrar, M., 2006. Adsorption and Desorption Characteristics of Natural Organic Matter in Natural Waters on Granular Activated Carbon. M.S. Thesis, University of Ottawa, Canada.

Suffet, I.H., Corado, A., Chou, D., McGuire, M.J., Butterworth, S., 1996. American Water Works Association taste and odor survey. *Journal of American Water Works Association*, 88, 4, 168-180.

Summerfelt, S.T., 2006. Design and management of fluidized-bed biofilters, *Aquacultural Engineering*, 34, 275-302.

Summers, R.S., Roberts, P.V., 1988. Activated carbon adsorption of humic substances: II. Size exclusion and electrostatic effects. *Journal of Colloid and Interface Science*, 122, 382-389.

Suzuki, M.T., Giovannoni, S.J., 1996. Bias caused by template annealing in the amplification of mixtures of 16S rRNA genes by PCR. *Applied and Environmental Microbiology*, 62, 625-630.

Suzuki, M.T., Haimberger, M.S., Winfield, H., Adair, N., Ströbel, J., Giovannoni, S. J., 1997. Bacterial diversity among small-subunit rRNA gene clones and cellular isolates from the same seawater sample. *Applied and Environmental Microbiology*, 63, 983-989.

Takeuchi, Y., Mochidzuki, K., Matsunobu, N., Kojima, R., Motohashi, H., Yoshimoto, S., 1997. Removal of organic substances from water by ozone treatment followed by biological activated carbon treatment. *Water Science and Technology*, 35, 7, 171-178.

Tekerlekopoulou, A.G., Vayenas, D.V., 2008. Simultaneous biological removal of ammonia, iron and manganese from potable water using trickling filter. *Biochemical Engineering Journal*, 39, 215-220.

Terzyk, A., 2001. The influence of activated carbon surface chemical composition on the adsorption of acetaminphen (paracetamol) in vitro, Part II: TG, FTIR and XPS Analysis of Carbons and the Temperature dependency of adsorption kinetics at the neutral pH. *Colloids and Surfaces A: Physicochemical and Engineering Aspects*, 177, 23-45.

Thompson, J.D., Higgins, D.G., Gibson, T.J., 1994. CLUSTALW: improving the sensitivity of progressive multiple sequence alignment through sequence weighting, position specific gap penalties, and weight matrix choice. *Nucleic Acids Research*, 22, 4673-4680.

Thurman, E.M., 1985, In: *Organic Geochemistry of Natural Waters*, Ed. Martinus Nijhoff, Dr W. Junk Publishers, Dordrecht, The Netherlands.

Traenckner, J., Wricke, B., Krebs, P., 2008. Estimating nitrifying biomass in drinking water filters for surface water treatment. *Water Research*, (in press).

Traina, S.J., Novak, J., Smeck, N.E., 1990. An ultraviolet absorbance method of estimating the percent aromatic carbon content in humic acids. *Journal of Environmental Quality*, 19, 1, 151-153.

Trebesius, K., Amann, R.I., Ludwig, W., Mulegger, K., Schleifer, K.H., 1994. Identification of whole fixed bacterial cells with nonradiative ²³S rRNA-targeted polynucleotide probes. *Applied and Environmental Microbiology*, 60, 3228-3235.

Trulleyová, S., Rulík, M., 2004. Determination of biodegradable dissolved organic carbon in waters: Comparison of batch methods. *Science of the Total Environment*, 332, 253– 260.

Uhl, W., 2000a. Biofiltration Processes for Organic Matter Removal. In Rehm H.J., Reed G. (Eds), *Biotechnology*, Second Revised Edition, 11c, Wiley VCH, Weinheim, N.Y.

Uhl, W., 2000b. Einfluss von Schüttungsmaterial und Prozessparametern auf die Leistung von Bioreaktoren bei der Trinkwasseraufbereitung, Ph.D. Dissertation, IWW Schriftenreihe, Germany.

Uhl, W., Gimbel, R., 2000. Dynamic modeling of ammonia removal at low temperatures in drinking water rapid filters. *Water Science and Technology*, 41, 4-5, 199-206.

Urbain, V., Benoid, R., Manem, J., 1996. Membrane bioreactor: A new treatment tool. *Journal of American Water Works Association*, 88, 5, 75–86.

Urfer, D., Huck, P.M., Booth, S.D.J., Coffrey, B.M., 1997. Biological filtration for BOM removal: A critical review. *Journal of American Water Works Association*, 89, 12, 83-98

Urfer, D., 1998. Effects of Oxidants on Drinking Water Biofilters, Ph.D. Dissertation, The University of Waterloo, ON, Canada.

USEPA, 2000 United States Environmental Protection Agency, Manual, Nitrogen Control, EPA-625-R-93-010, Office of Research and Development, Risk Reduction Engineering Laboratory, Cincinnati, 1993.

van der Hoek, J.P., Hofman, J.A.M.H., Graveland, A., 1999. The use of biological activated carbon filtration for the removal of natural organic matter and organic micropollutants from water. *Water Science and Technology*, 40, 9, 257–264.

van der Kooij, D., Visser, A., Hijnen, W.A.M., 1982. Determining the concentration of easily assimilable organic carbon in drinking water. *Journal of American Water Works Association*, 74, 540-545.

van der Kooij, D. 1995. Significance and assessment of the biological stability of drinking water, In: *Water Pollution: Quality and Treatment of Drinking Water*, Springer-Verlag, New York, 89–102

van Hulle, S.W.H., Verstraete, J., Hogie, J., Dejans, P., Dumoulin, A., 2006. Modelling and simulation of a nitrification biofilter for drinking water purification. *Water SA*, 32, 2, 252-264.

Voice, T.C., Pak, D., Zhao, X., Shi, J., Hickey, R.P., 1992. Biological activated carbon in fluidized bed reactors for the treatment of groundwater contaminated with volatile aromatic hydrocarbons. *Water Research*, 26, 10, 1389-1401.

Volk, C., Renner, C., Roche, P., Paillard, H., Joret, J.C., 1993. Effects of ozone on the production of biodegradable dissolved organic carbon (BDOC) during water treatment. *Ozone Science and Engineering*, 15, 389-404.

Volk, C., LeChevallier, M.W., 2000. Assessing biodegradable organic matter. *Journal of American Water Works Association*, 92, 5, 64-76.

Volk, C.J., Volk, C.M., Kaplan, L.A., 1997. Chemical composition of biodegradable dissolved organic matter in stream water. *Limnology and Oceanography*, 42, 39-44.

Volk, C.J., Bell, K., Ibrahim, E., Verges, D., Amy, G., LeChevallier, M., 2000. Impact of enhanced coagulation on removal of organic matter and its biodegradable fraction. *Water Research*, 34, 3247- 3257.

Volk, C., LeChevallier, M.W., 2002. Effects of conventional treatment on AOC and BDOC levels. *Journal of American Water Works Association*, 94, 6, 112-123.

Vuoriranta, P., Remo, S., 1994. Bioregeneration of activated carbon in a fluidized GAC bed treating bleached kraft mill secondary effluent. *Water Science and Technology*, 29, 239-246.

Wagner, M., Rath, G., Koops, H.P., Flood, J., Amann, R., 1996. In situ analysis of nitrifying bacteria in sewage treatment plants. *Water Science and Technology*, 34, 237-244.

Wagner, M., Rath, G., Amann, R., Koops, H.P., Schleifer, K.H., 1995. In situ identification of ammonia-oxidizing bacteria. *Systematic and Applied Microbiology*, 18, 251-264.

Wagner, M., Noguera, D.R., Juretschko, S., Rath, G., Koops, H.P., Schleifer, K.H., 1998. Combining fluorescent in situ hybridization (FISH) with cultivation and mathematical modeling to study population structure and function of ammonia oxidizing bacteria in activated sludge. *Water Science and Technology*, 37, 441-449.

Walker, G.M., Weatherley, L.R., 1997. A simplified predictive model for biologically activated carbon fixed beds. *Process Biochemistry*, 32, 327-335.

Walker, G.M., Weatherley, L.R., 1998. Bacterial regeneration in biological activated carbon systems. *Process Safety and Environmental Protection*, 76, 177-182.

Wang, J.Z., Summers, R.S., Miltner, R.J., 1995. Biofiltration performance: Part I, Relationship to biomass. *Journal of American Water Works Association*, 87, 12, 55-63

Ward, D.M., Bateson, M.M., Weller, R., Ruff-Roberts, A.L., 1992. Ribosomal RNA analysis of microorganisms as they occur in nature. *Advances in Microbial Ecology*, 12, 219-286.

Weber, W.J. Jr., Pirbazari, M., Melson, G.L., 1978. Biological growth on activated carbon: an investigation by scanning electron microscopy. *Environmental Science and Technology*, 12, 7, 817-819.

Weinberg, H., Glaze, W.H., Krasner, S.W., Schlimenti, M.C., 1993. Formation and removal of aldehydes in plants that use ozonation. *Journal of American Water Works Association*, 85, 5, 72-85.

Wert, C.E., Neemann, J.J., Rexing, D.J., Zegers, R.E., 2008. Biofiltration for removal of BOM and residual ammonia following control of bromate formation. *Water Research*, 42, 372-378.

Win, Y.Y., Kumke, M.U., Specht, C.H., Schindelin, A.J., Kollipulos, G., Ohlenbusch, G., Kleiser, G., Hesse, S., Friml, F.H., 2000. Influence of oxidation of dissolved organic carbon (DOM) on subsequent water treatment processes. *Water Research*, 34, 7, 2098-2104.

Wise, M.G., McArthur, J.V., Shimkets, L. J., 1997. Bacterial diversity of a Carolina bay as determined by 16S rRNA gene analysis: Confirmation of novel taxa. *Applied and Environmental Microbiology*, 63, 1505-1514.

Yapsaklı, K., Çeçen, F., Aktaş, Ö., Can, Z.S., 2008. Impact of surface properties of granular activated carbon and preozonation on adsorption and desorption of natural organic matter. *Environmental Engineering Science*, accepted for publication.

Yavich, A.A., Lee, K.H., Cehn, K.C., Pape, L., Maten, S.J., 2004. Evaluation of biodegradability of NOM after ozonation. *Water Research*, 38, 2839-2846.

Yordanov, R.V., Lamb, A.J., Melvin, M.A.L., Littlejohn, J., 1996. Biomass Characteristics of Slow Sand Filters Receiving Ozonated Water. In Graham, N., Collins, R. (Eds.), *Advances in Slow Sand and Alternative Biological Filtration*, 107-118, John Wiley & Sons, Chichester.

Yu, X., Qi, Z., Zhang, X., Yu, P., Liu, B., Zhang, L., Fu, L., 2007. Nitrogen loss and oxygen paradox in full-scale biofiltration for drinking water biofilters. *Water Research*, 41, 1455-1464.

Zhang, M., Huck, P.M., 1996. Biological water treatment: A kinetic modeling approach. *Water Research*, 30, 5, 1195-1205.

Zhang, M., Semmens, M.J., Schuler, D., Hozalski, R.M., 2002. Biostability and microbiological quality in a chloraminated distribution system. *Journal of American Water Works Association*, 94, 9, 112-122.

Zhao, X., Hickey, R.F., Voice, T.C., 1999. Long-term evaluation of adsorption capacity in a biological activated carbon fluidized bed reactor system. *Water Research*, 33, 13, 2983-2991.

APPENDIX A

TOC AND TN CALIBRATION CURVES

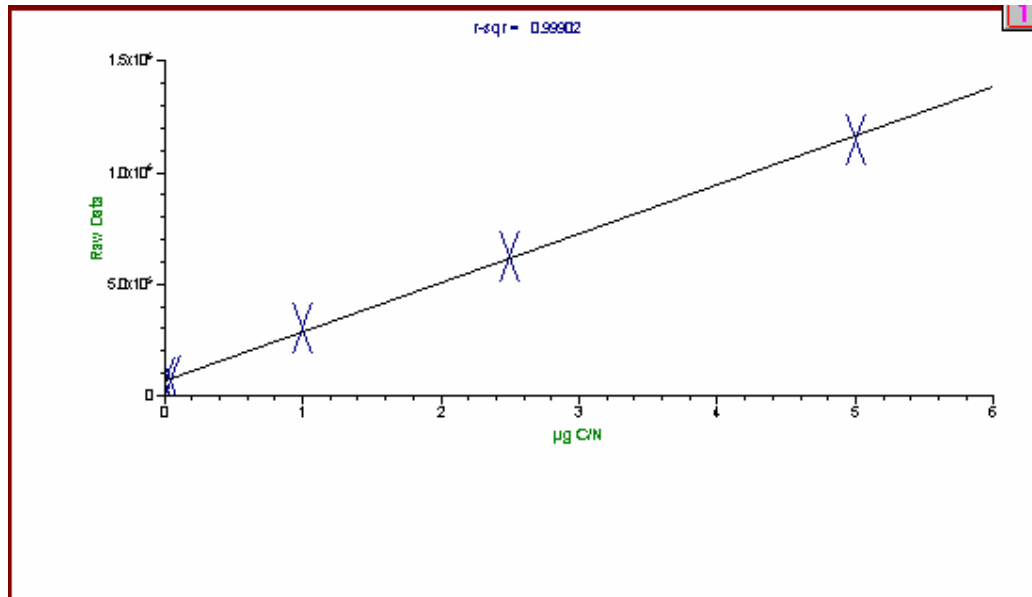


Figure A.1 An example of TOC calibration curve

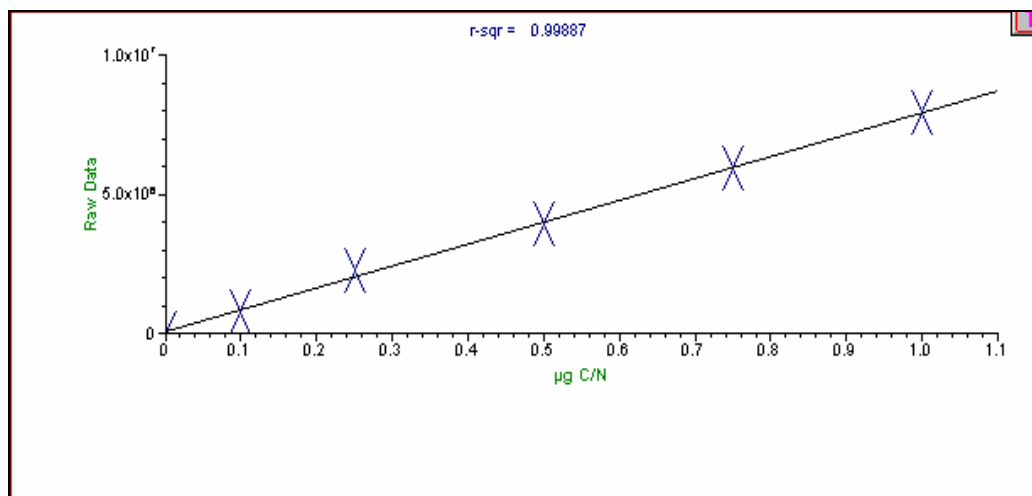


Figure A.2 An example of TN calibration curve

APPENDIX B
LANGMUIR ISOTHERMS BASED ON DOC MEASUREMENTS

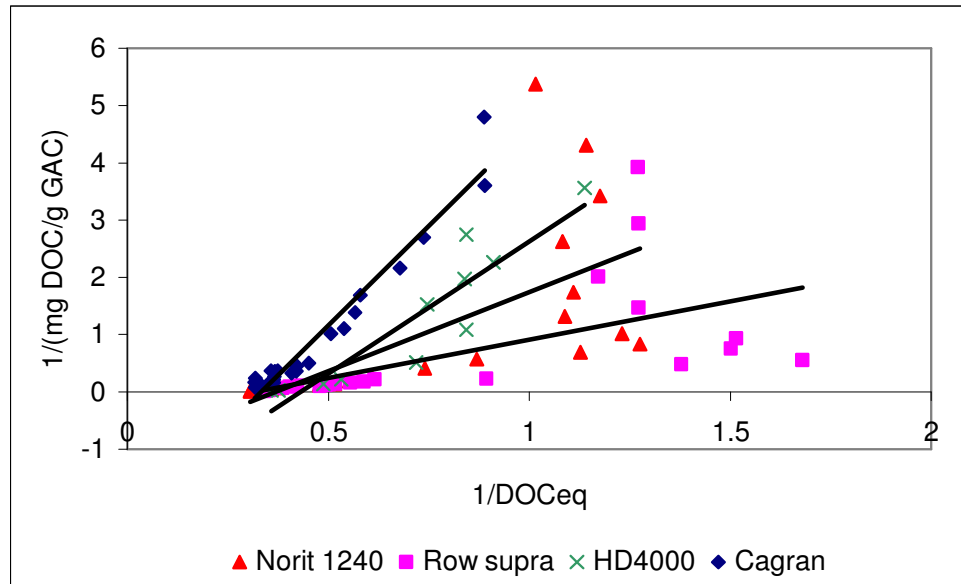


Figure B.1 Langmuir adsorption isotherms of different GACs tested with raw water

Table B.1 Langmuir coefficients of different GACs

	Q	b	R ²
Row Supra	2.38	0.32	0.36
Norit 1240	0.98	0.37	0.43
HD 4000	0.50	0.43	0.84
CAgran	0.43	0.33	0.94

APPENDIX C (Continued)

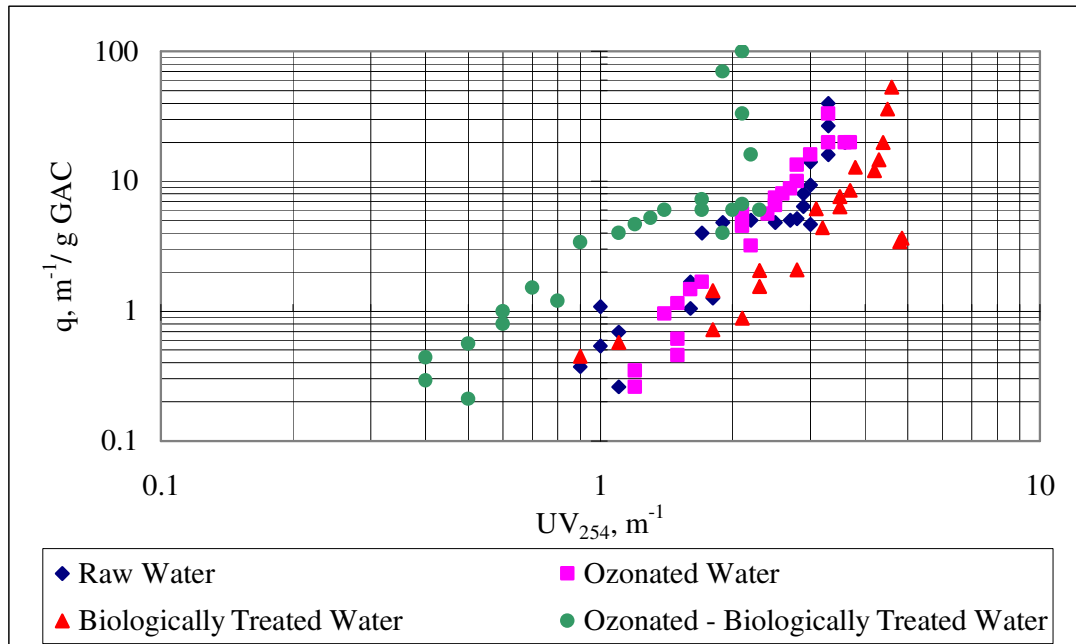


Figure C.3 Freundlich isotherms for the CAgran based on UV_{254} parameter

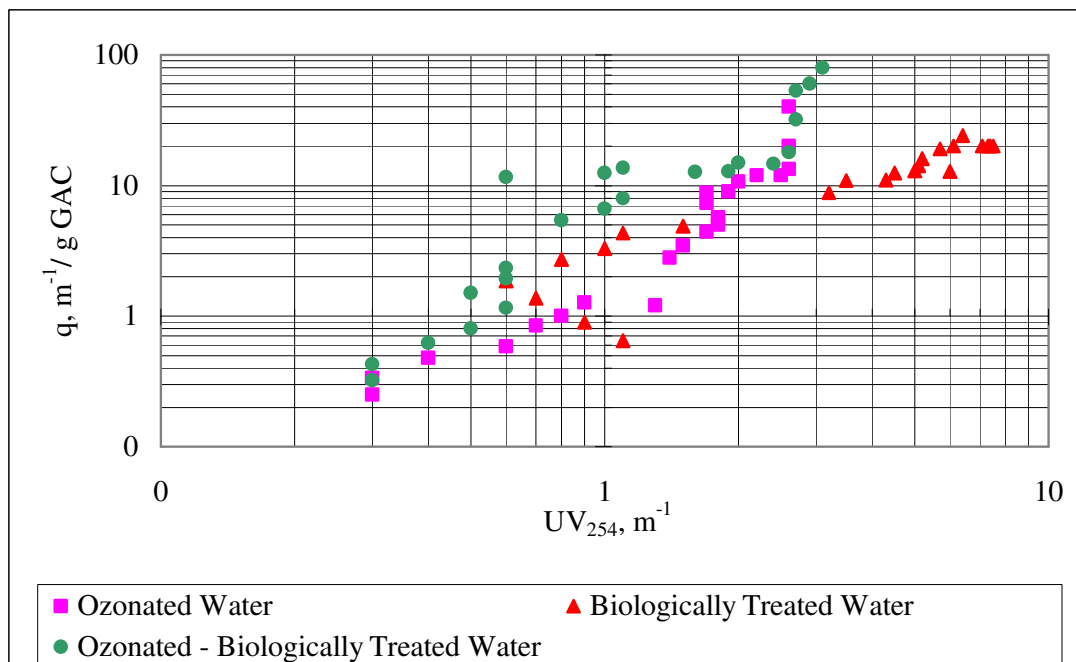


Figure C.4 Freundlich isotherms for the HD 4000 based on UV_{254} parameter

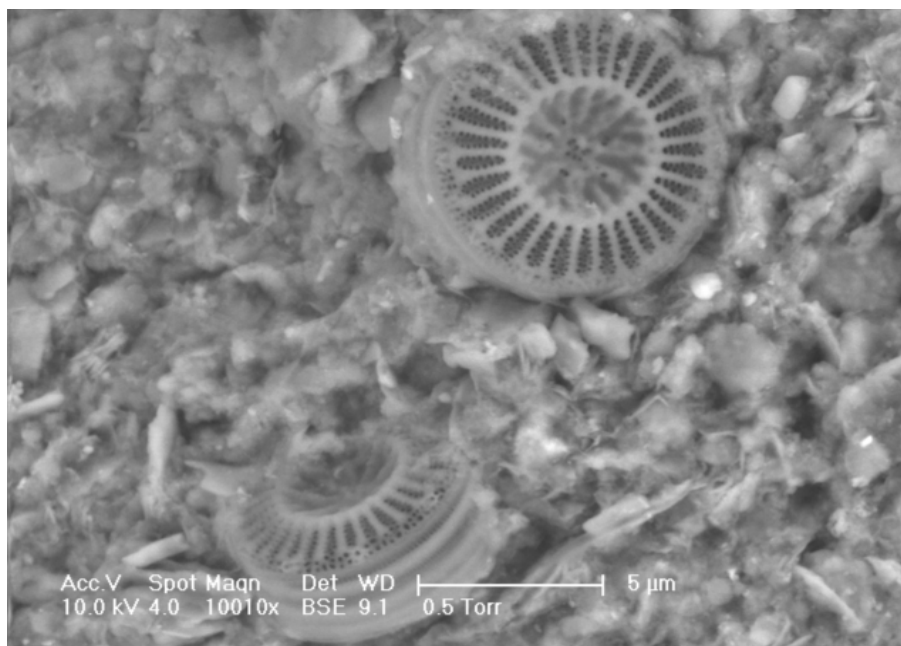
APPENDIX D**ESEM IMAGES OF SAMPLES TAKEN FROM BAC COLUMNS**

Figure D.1 Ectoparasitic Protozoa: trichodinids identified in ESEM image

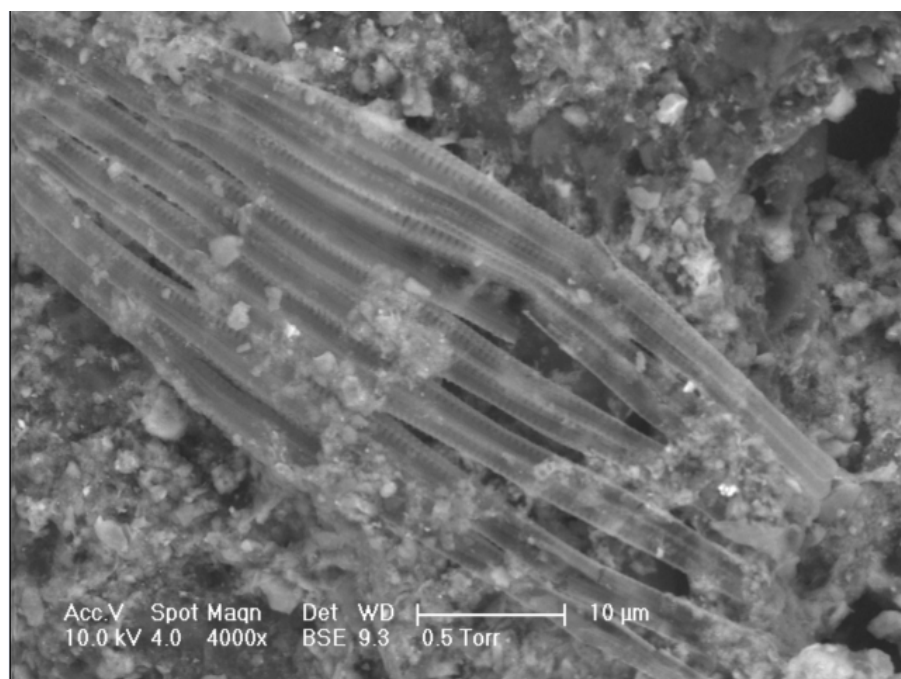
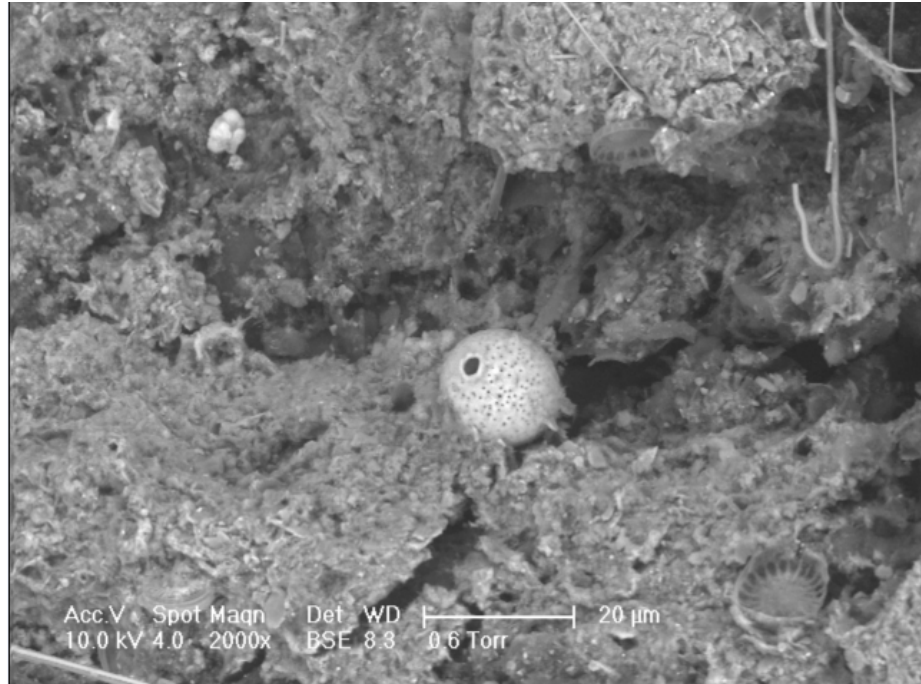
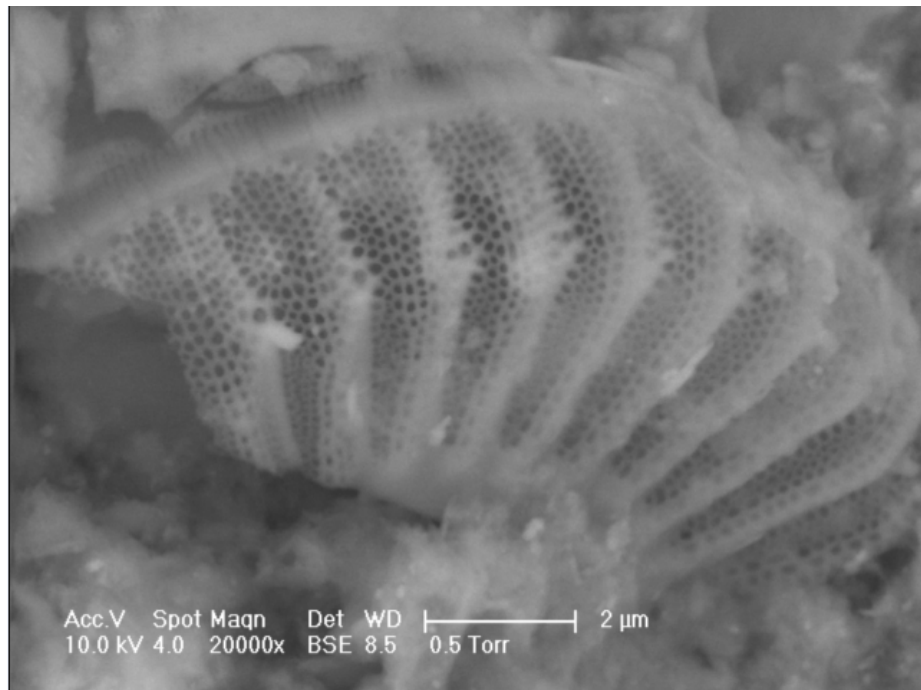


Figure D.2 Worm like higher organisms found in BAC columns

APPENDIX D (Continued)

(a)



(b)

Figure D.3 Various organisms found in BAC columns

APPENDIX E

SIMULATION RESULTS OF UHL'S MODEL

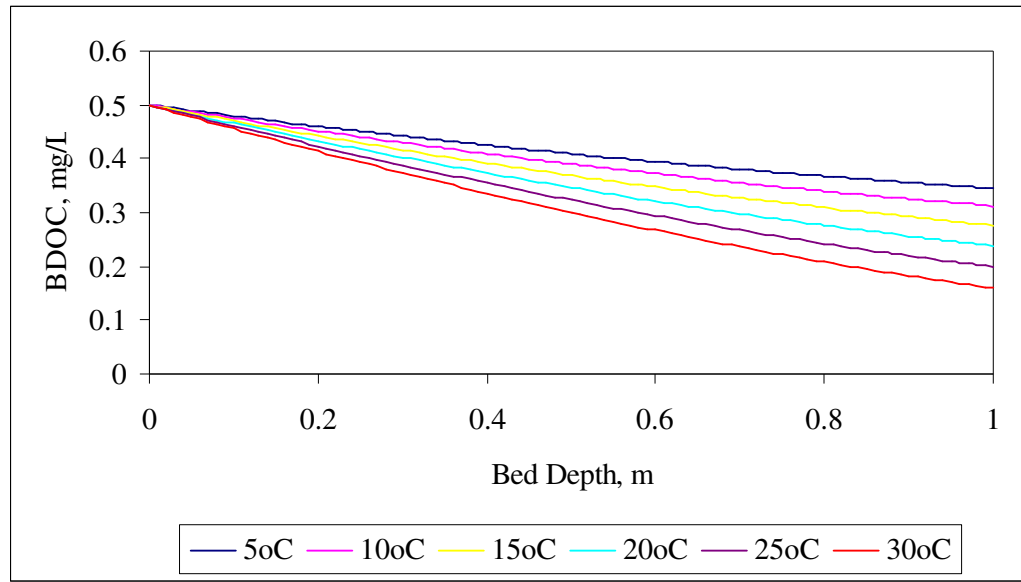


Figure E.1 Simulation results of the effect of temperature on the BDOC removal along the bed depths

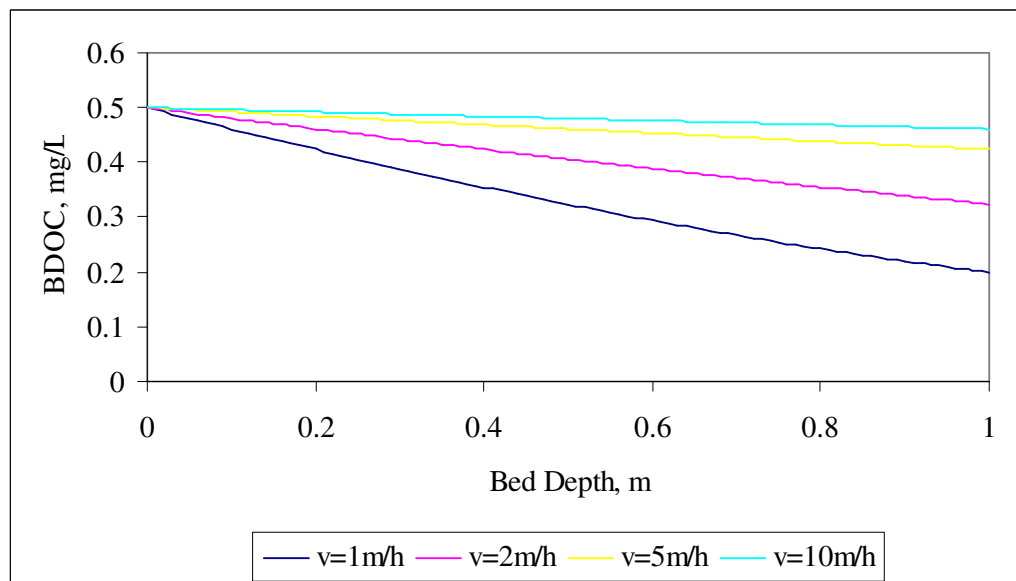


Figure E.2 Simulation results of the effect of hydraulic loading on the BDOC removal along the bed depth

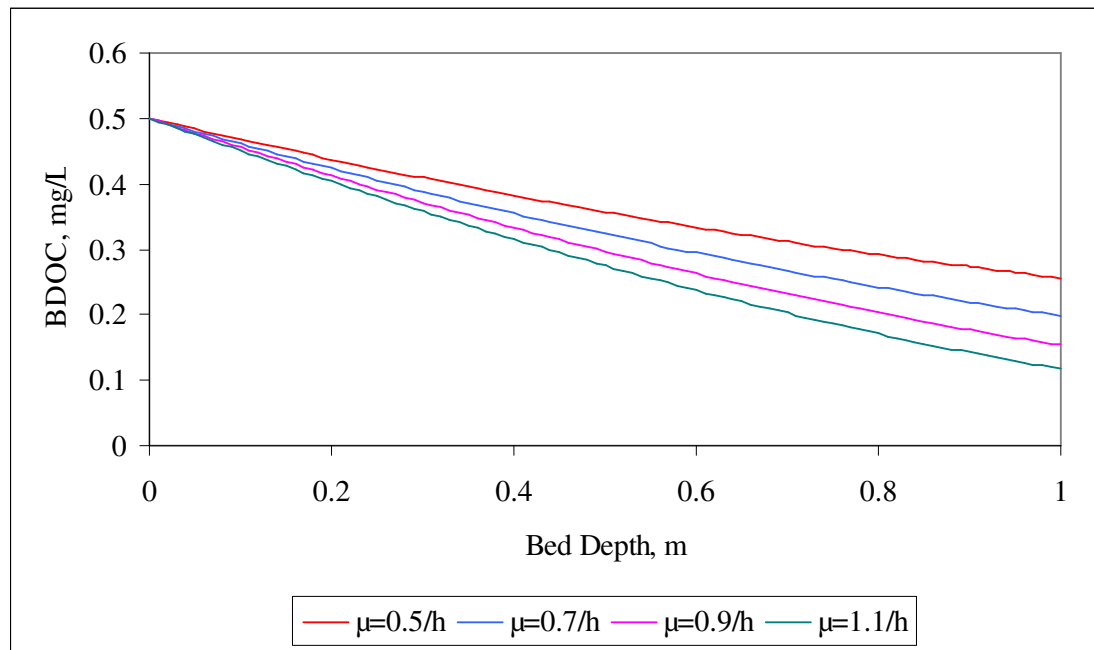


Figure E.3 Effect of maximum specific bacterial growth rate on BDOC removal along the bed depth

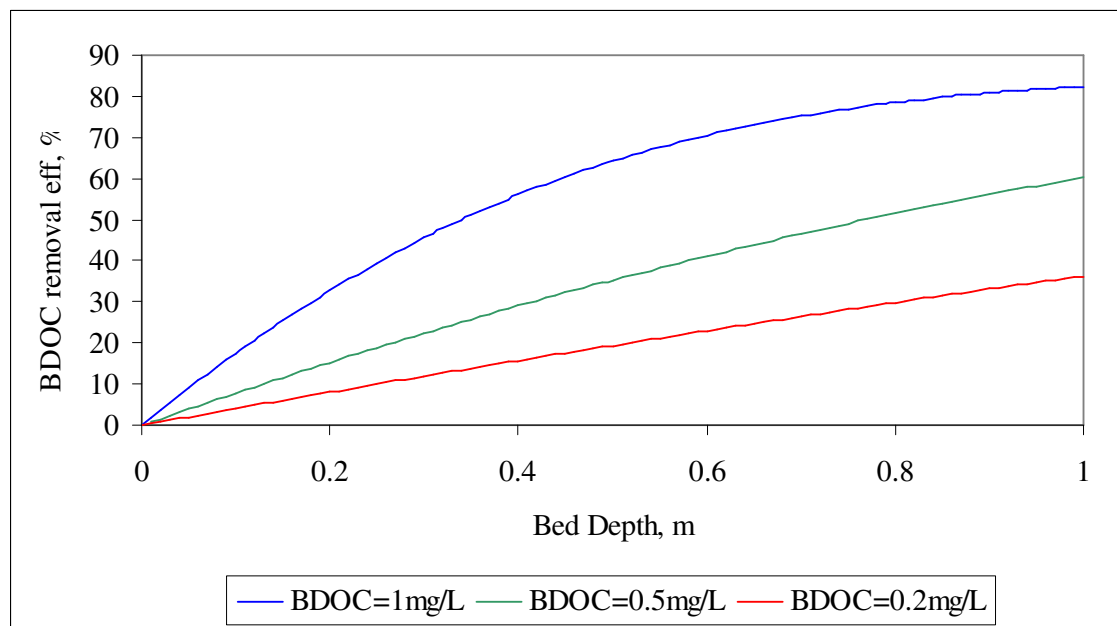


Figure E.4 Effect of initial BDOC concentration on the removal efficiency at various bed depths with a hydraulic loading of 1m/h