

FOR REFERENCE

NOT TO BE TAKEN FROM THIS ROOM

IMPROVING MEDICAL DIAGNOSTIC INFORMATION THROUGH  
BETTER USAGE OF FILM TECHNOLOGY

by

VAHİT KONGUR

B.Sc. in E.E., Boğaziçi University, 1984

Submitted to the Biomedical Engineering  
Institute in partial fulfillment of the  
requirements for the degree of

master of Science

in

Biomedical Engineering

Bogazici University Library



39001100314163

14

Boğaziçi University

JUNE, 1986

TO MY DEAR MOTHER . . . . .

## ACKNOWLEDGEMENTS

I would like to express my sincere gratitude to my thesis supervisor Dr. Albert GÜVENİŞ for his guidance, useful suggestions and great support during the preparation of this thesis.

I would also like to thank Prof. Dr. Necmi TANYOLAÇ and Dr. Ahmet DENKER for all their help.

## ABSTRACT

Photographic Quality Assurance is an important element of the quality assurance programs as applied in medical diagnostic imaging centers. This thesis addresses the problem of optimizing image quality in Turkey with respect to X-ray film management procedures. First a sensitometric study has been conducted in 32 diagnostic centers in Istanbul in order to find out the major problems encountered in darkrooms and processors. Then a quality assurance programme has been implemented in a private clinic for a period of one month. Both studies indicate a need for quality assurance programmes in Turkey in order to increase diagnostic image quality and decrease unnecessary radiation dose to the patient. Film purchasing policy in Turkey and its potential effects on film quality have also been discussed in this thesis.

## ÖZET

Fotoğraflamada yüksek kalite temini tıbbi görüntüleme merkezlerinde uygulanan kalite kontrol programlarının önemli bir elemanıdır. Bu tez Türkiye'de röntgen filmine bağlı olarak ortaya çıkan görüntü kalite problemini optimize etmek amacıyla hazırlanmıştır. İlk önce, İstanbul'da 32 tetik merkezinde karanlıkoda ve filim banyo sistemlerindeki başlıca problemleri ortaya koymak için sensitometrik çalışma yapılmıştır. Daha sonra özel bir klinikde, bir ay müddetle yüksek kalite temin programı uygulanmıştır. Her iki çalışma Türkiye'de görüntü kalitesini arttırmak ve hastaya verilen radyasyon dozunu azaltmak için yüksek kalite temin programlarının gerekliliğini ortaya koymuştur. Türkiye'deki filim satın alma politikası ve bunun filim kalitesindeki potansiyel etkileri de bu tezin içersinde tartışılmıştır.

## TABLE OF CONTENTS

	<u>Page</u>
ACKNOWLEDGEMENTS	iv
ABSTRACT	v
ÖZET	vi
I, INTRODUCTION	1
1.1. Purpose Of This Thesis	1
1.2. Contents Of This Thesis	5
1.3. References	7
II. PHYSICAL CHARACTERISTICS OF X-RAY FILM AND FILM PROCESSING	9
2.1. Physical Characteristics Of X-Ray Film	9
2.2. Film Processing	19
2.2.1. Development	19
2.2.2. Replenishment	22
2.2.3. Fixing	23
2.2.4. Washing	25
2.2.5. Drying	26
2.3. Figures	27
2.4. References	32
III. PHOTOGRAPHIC CHARACTERISTICS OF X-RAY FILM	33
3.1. Introduction	33
3.2. Photographic Density	34

	<u>Page</u>
3.3. Characteristic Curve	38
3.3.1. Film Contrast	40
3.4. Speed	46
3.5. Lattitude	47
3.6. Figures	49
3.7. References	57
IV. DARKROOM CONDITIONS AND DESIGN	59
4.1. Introduction	59
4.2. Light Fog In The Radiographic Darkroom	59
4.3. How To Properly Measure Fog	63
4.4. Installation Of The Processing Room	64
4.5. Figures	68
4.6. References	69
V. PHOTOGRAPHIC QUALITY ASSURANCE IN DIAGNOSTIC RADIOLOGY, NUCLEAR MEDICINE AND RADIATION THERAPY	71
5.1. Basic Equipment, Materials, And Material Handling For Photographic Quality Assurance	71
5.1.1. Sensitometers	71
5.1.2. Photographic Control Emulsion	72
5.1.3. Densitometers	73
5.1.4. Thermometers	74
5.1.5. Residual Fixer Test Materials	75

	<u>Page</u>
5.2. Daily Quality Assurance Procedures: Establish- ment And Maintenance Of A Quality Assurance Program	76
5.2.1. Processor Maintenance Logs	76
5.2.2. Variability In Radiographic Processing	81
5.2.3. Processing Control Charts	81
5.2.4. Exposing And Processing Sensitometric Control Strips	84
5.2.5. Establishing Operating Levels And Control Limits	88
5.2.6. Corrective Action	90
5.3. Daily Quality Assurance Checks	95
5.4. Weekly Quality Assurance Checks	94
5.5. Residual Fixer Tests	101
5.6. Monthly Quality Assurance Checks	101
5.7. Other Periodic Quality Assurance Procedures	102
5.8. Seasoning The Processor Tanks And Racks	103
5.9. Figures	106
5.10. References	109
VI. IMPLEMENTATION OF QUALITY CONTROL FOR A MANUAL PROCESSOR	112
6.1. Manual Treatment Of Medical X-Ray Films	112
6.2. Implementation Of A Quality Control Programme For A Manual Processor In Istanbul	120

	<u>Page</u>
6.3. Figures	124
6.4. References	127
VII. SURVEY OF PROCESSORS IN ISTANBUL AREA	128
7.1. Introduction	128
7.2. Theory	128
7.3. Observations	130
7.4. Comparision With Study Conducted In The State Of New Jersey	132
7.5. Figures	135
7.6. References	150
VIII. FILM STORAGE AND HANDLING	152
8.1. Storage Conditions	152
8.2. Frozen Storage Conditions	153
8.3. Radiation Levels In Storage Areas	154
8.4. Film Handling	155
8.5. Figures	157
8.6. References	160
IX. HOW TO PURCHASE RADIOGRAPHIC MATERIALS	162
9.1. Evaluation Of Sensitized Photographic Materials	162
9.2. Acceptance Testing Of Radiographic Materials	169
9.3. Figures	172

	<u>Page</u>
9.4. References	173
X. FILM PURCHASING POLICY IN TURKEY	174
10.1. References	175
XI. CONCLUSION	176

## CHAPTER I.

### INTRODUCTION

#### 1.1. PURPOSE OF THIS THESIS

The quality of a radiologic system is measured by its weakest link. X-ray film is a major component in medical diagnostic imaging systems. When equipment and technique related factors are maintained at high quality, then bad utilization of X-ray films can lead to partial or complete loss of diagnostic information, higher dose to the patient, more repeat exams, and film waste. The patient's health is then compromised. Furthermore, the department's expenses grow due to reasons like wasted chemicals and films, shortened tube life (because of high radiation outputs), etc. Therefore, good utilization of X-ray films is essential in maintaining a high quality diagnostic imaging center (1, 4, 5, 8).

For better utilization of X-ray films proper dark-room and processing techniques as well as good quality assurance programs are needed (1, 10).

In a study conducted by the World Health Organization (WHO) in Kenya in 1980 (11), the reason for poor diagnosis has been found to be improper processing techniques of X-ray films in a 50% amount. Several studies seem to confirm these findings (3,5).

Since processing is one of the cheapest elements in a medical diagnostic imaging center, its improvement can save us from the many problems encountered in the most effective way. The implementation of photographic quality control procedures and training of technologists for proper film processing are fairly simple and inexpensive (6).

Quality Assurance programs which started in the 1970's by collaborative work of FDA (Food and Drug Administration) of the USA, IAEA (International Atomic Energy Commission) and WHO, these programs have been made mandatory in several countries like the USA by implementing governmental regulations. In certain countries, quality assurance programs are only voluntary but strongly advised. In many instances the radiologist recognizes and understands the need for such programs; he knows the major benefits of quality assurance programs in providing a better service to his patients and reducing departmental costs. Several studies give concrete figures to affirm that quality assurance programs increase diagnostic information, reduce unnecessary exposure to the patient and personnel and increase the cost effectiveness of the

department. The number of repeat exams also decrease (4, 9, 12). See Figure 1.1.

No effort has been made in implementing Quality Assurance programs in Turkey yet. In this thesis, an attempt has been made to evaluate film quality in various hospitals and clinics in Turkey and to determine the need for such programs in Turkey. 32 centers in the Istanbul area have been surveyed. In this survey, the same techniques were used as in the evaluation conducted by the BRH (Bureau of Radiological Health) of the USA in the State of New Jersey in 1982 (13). In addition to this sensitometric evaluation, we have studied the film purchasing and storing policies of Turkey. Every effort has been attempted to assess the present state of film quality in Turkey and the needs to improve it. After the assessment of needs we have conducted a pilot quality assurance program in a private clinic to assure that film quality can be improved by quality assurance techniques.

	REPEAT RATE		WASTE FILM RATE	
	Before Q.C. (%)	After Q.C. (%)	Before Q.C. (%)	After Q.C. (%)
University of Connecticut	14.3	8.4		
Baltimore PHS Hospital	8.0	6.2		
Donelson Hosp. (Nashville, TN)	9-10	3-5		
Hammond Clinic			6.5-8	2.75-3.75
Medical College of Virginia	8.0	3.0		
Marton F. Plant Hospital (Clearwater, FL)			12.6	6.2
Mc Laren Hosp. (Flint, MI)	10.0	7.4		
Mercy Hosp. (Baltimore, MD)	14.0	8.6	24.0	13.6
Fountain Valley Com. Hosp. (Fountain Valley, CA)	15.0	7.7		
Mercy Hosp. (Davenport, IA)	14.0	7.5		
Oklahoma Children's Memorial (Oklahoma City, OK)	5.0	2.5		

Figure 1.1. Film waste and repeat rates before and after quality control procedures in various hospitals in the USA.

## 1.2. CONTENTS OF THIS THESIS

In chapter 2, physical characteristics of X-ray films and film processing are discussed. The chemical reactions, and physical changes in X-ray films during film processing are discussed.

In chapter 3, you will find a description of photographic characteristics of X-ray films such as photographic density, characteristic curve, base plus fog, contrast, speed and latitude.

Chapter 4 includes a discussion of proper darkroom design and optimization of light fog in the darkroom.

In chapter 5, the basic equipment and material necessary for quality assurance procedures will be presented. Then daily, weekly and monthly quality assurance procedures will be described.

Chapter 6 deals with the implementation of quality control for a manual processor. In this chapter, daily quality assurance procedures conducted in one clinic throughout a month will be described and the obtained results will be discussed.

In chapter 7, we will present the results of our survey conducted in Istanbul and also compare the observations obtained from Istanbul with those obtained from the State of New Jersey conducted in 1982 by the BRH.

How the films shall be stored, what the radiation level shall be in storage areas and how we shall handle the films will be explained in chapter 8. In accordance to chapter 8, chapter 9 and chapter 10 discuss the techniques used in purchasing of photographic materials and the film purchasing policy in Turkey respectively.

In the conclusion part (Chapter 11) we will discuss our observations from the survey work conducted in the Istanbul area and we will give the reasons for the pitfalls due to poor film processing techniques. The results obtained from our pilot quality assurance program will be discussed. Finally, the need for initiating rigorous quality assurance programs in Turkey will be justified in terms of our findings.

CHAPTER IREFERENCES

1. World Health Organization, "Quality Assurance in Diagnostic Radiology," Geneva 1982.
2. C.L. Hall, "Economic Analysis of a Quality Control Program", Application of Optical Instrumentation in Medicine, VI. Proceedings of the Society of Photo-Optical Instrumentation Engineers, 127: 271 (1977).
3. J. Gray, "The Basic Principles of Daily Photographic Quality Assurance", HEW Publications, FDA, 76-8043.
4. L. Goldman, J.J. Vucich, S. Beech, S. and W.L. Murphy, "Automatic Processing Quality Assurance Program", Impact on a Radiology Department, Radiology, 125: 591-595, 1977.
5. M.R. Brown, "Preventive Maintenance Reduces X-Ray Equipment Costs", Dimensions in the Health Service, 51:3, 1974.
6. R.E. Nelson et.al., "Economic Analysis of a Comprehensive Quality Assurance Program", Radiol. Technol., 40: 120-134, 1977.

7. T.C. Barber, J.M. Thomas, "Radiologic Quality Control Manual, Reston Publishing Company, 1983".
8. Joel Gray et.al., "Quality Control in Diagnostic Imaging", the Maya Foundation, Published by Aspen Systems Corporation, 1983.
9. R.S. Noyes, "The Economics of Quality Assurance", Radiology/Nuclear Medicine Magazine, pp. 7-9, 24, 28, 1978.
10. P.E.S. Palmer. Univ. of California, Davis California, USA. "Manual of Darkroom Technique" WHO Basic Radiological System, Geneva, 1985.
11. L.R. Whittaker, "Quality Control in X-Ray Departments at Kenyan District Hospitals", Radiation Medicine, WHO, Geneva, 1980.
12. L.W. Goldman, "Analysis of Retakes: Understanding, Managing and Using an Analysis of Retakes Program for Quality Assurance" HEW Publication (FDA) 79-8097, U.S. Department of Health, Education and Welfare, Washington. D.C.
13. BRH, "A Sensitometric Evaluation of Film-Chemistry. Processor Systems in the State of New Jersey" HHS Publication FDA 82-8189, April 1982.

## CHAPTER II.

### PHYSICAL CHARACTERISTICS OF X-RAY FILM AND FILM PROCESSING

When an X-ray beam reaches the patient, it contains no useful information. After the beam passes through and interacts with the tissues in the part examined, it contains the information that the particular radiographic examination can give. This information is represented by a variation in the number of X-ray photons in different areas of the emergent beam. The most important material used to "decode" the information carried by the attenuated X-ray beam is the photographic film. More commonly, the energy of the X-ray beam is converted into light by intensifying screens, and this light is used to expose the film.

#### 2.1. PHYSICAL CHARACTERISTICS OF X-RAY FILM

X-ray film is photographic film consisting of a photographically active or radiation-sensitive emulsion which is usually coated on both sides of a transparent sheet of plastic called the base. Firm attachment between the emulsion layer and the film base is achieved by a thin layer of adhesive. The delicate emulsion is protected from mechanical damage by layers known as the supercoating (Figure 2.1).(4)

### Film Base

The only function of the film base is to provide support for the fragile photographic emulsion. Three characteristics of the base must be considered. First, it must not produce a visible pattern or absorb too much light when the radiograph is viewed. Second, the flexibility, thickness, and strength of the base must allow for ease of processing (developing) and produce a radiograph that "feels right" when handled (a film too "floppy" to "snap" under the hangers of a viewbox gets a cool reception). Third, the base must have a dimensional stability; that is, the shape and size of the base must not change during the developing process or during the stored life of film. (Wrinkled emulsion results from shrinking of the base). (1)

In early days of radiology, prior to World War I, radiographic films were made on glass plates. However, because of breakage, storage and a greater demand for radiographic films, a new material called cellulose nitrate was developed in order to record the image. The introduction of this new base material presented a fire hazard problem. Demands for a material less flammable and with greater efficiency led researchers to develop a film base of cellulose triacetate. The new safety base of cellulose triacetate was first introduced in 1924. This acetate-base safety film

(cellulose-acetate will burn if held directly in a flame) is still widely used. In 1960, the first medical radiographic film using a polyester base was introduced. Polyester as a film base offers the advantage of improved dimensional stability, even when stored under the conditions of varying humidity, and it is much stronger than acetate. (7)

Photographic emulsion would not adhere to the finished base if applied directly. Therefore, a thin layer of adhesive substance is applied to the base to insure perfect union between base and emulsion.

### Emulsion

The two most important ingredients of a photographic emulsion are gelatin and silver halide. Emulsion thickness will vary with film type but is usually no thicker than 0.5 mil. A thicker emulsion would not be useful because of the inability of light to penetrate to the deeper layers.

### Gelatin :

Photographic gelatin for X-ray film is made from bone, mostly cattle bone. Gelatin satisfies several exacting requirements better than any other suspension medium. It keeps the silver halide grains well dispersed and pre-

vents the clumping of grains. Processing (developing and fixing) solutions can penetrate gelatin rapidly without destroying its strength or permanence, and gelatin is available in reasonable large quantity and uniform quality.

#### Silver-halide :

Silver halide is the light-sensitive material in the emulsion. The halide in medical X-ray film is about 90 to 99% silver bromide and about 1 to 10% silver iodide (the presence of Ag I produces an emulsion of much higher sensitivity than a pure AgBr emulsion). The silver iodobromide crystals are precipitated and emulsified in the gelatin under exacting conditions of concentration and temperature, as well as the sequence and the rate at which these chemicals are added. The method of precipitation determines crystal size, structural perfection, and the concentration of iodine. In general, the precipitation reaction involves the addition of silver nitrate to a soluble halide to form the slightly soluble silver halide: (3)



The silver halide in a photographic emulsion is in the form of small crystals suspended in the gelatin. The crystal is formed from ions of silver ( $\text{Ag}^+$ ), ions of bromine

(Br<sup>-</sup>) and ions of iodine (I<sup>-</sup>) arranged in a cubic lattice (Figure 2.2). (1,4)

These grains, or crystals, in a medical X-ray film emulsion are small, but still large compared to fine-grain photographic emulsions. Crystal size might average 1.0 to 1.5 microns (1 micron = 0.001 millimeter) in diameter with about  $6.3 \times 10^9$  grains per cubic centimeter of emulsion, and each grain contains an average of 1.000.000 to 10.000.000 silver ions.

A point defect in the silver iodo-bromide grain consists of a silver ion which has moved out of its normal position in the crystal lattice; these interstitial silver ions may move in the crystal causing a strain in the wall structure. (Figure 2.3)

Chemical sensitization of a crystal has several forms. Commonly, this is produced by adding a sulfur-containing compound, such as allylthiourea, to the emulsion which reacts with silver halide to form silver sulfide. The silver sulfide is usually located on the surface of the crystal and is referred to as the sensitivity speck.

It is the sensitivity speck which traps electrons to begin formation of the latent-image centers.

### Latent Image

Metallic silver is black. It is silver which produces the dark areas seen on a developed radiograph. (7)

The energy absorbed from a light photon gives an electron in the bromine ion enough energy to escape. The electron can move in the crystal for relatively large distances, so long as it does not encounter a region of impurity or fault in the crystal.



A site of crystal imperfection, such as a dislocation defect, or an AgS sensitivity speck, may act as an electron trap where the electron is captured and temporarily fixed. The electron gives the sensitivity speck a negative charge, and this attracts the mobile interstitial  $\text{Ag}^+$  ions in the crystal. At the speck, the silver ion is neutralized by the electron to form a single silver atom.

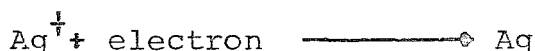

The single atom of silver then acts as an electron trap for a second electron. The negative charge causes a second silver ion to migrate to the trap to form a two-atom

silver nucleus. Growth of silver atoms at the site of the original sensitivity speck continues by repeated trapping of electrons and then neutralizing them with interstitial silver ions. The negative bromine ions that have lost electrons are converted into neutral bromine atoms which leave the crystal and are taken up by the gelatin of the emulsion. Figure 2.4 shows a schematic diagram of the development of a two-atom latent image according to the Gurney-Mott hypothesis (1).

A single silver halide crystal may have one or many of these centers in which atomic silver atoms are concentrated. The presence of atomic silver is a direct result of the response of the grain to light exposure, but no visible change has occurred in the grain. However, these small clumps of silver can be seen with electron microscopy. These clumps of silver atoms are termed latent-image centers and are the sites at which the developing process will cause visible amounts of metallic silver to be deposited. The difference between an emulsion grain that will react with the developing solution and thus become a visible silver deposit and a grain that will not be "developed" is the presence of one or more latent-image centers in the exposed grain. At least two atoms of silver must be present at a latent-image center to make a grain developable; i.e., to become a visible deposit of silver. In practical terms, however, the minimum number

to produce developability is probably between three and six. The more silver atoms which exist at a latent-image center, the greater is the probability that the grain will be developed. Some centers will contain several hundred silver atoms. Under the usual conditions, the absorption of one quantum of light by a silver halide grain will produce one atom of silver and one of bromine.

#### Direct X-Ray Exposure

The photographic effect of direct absorption of X-rays by the emulsion is not due to electromagnetic radiation itself, but it is caused by electrons emitted when the X-ray photon interacts with the silver halide in the emulsion. These electrons are derived from photoelectric absorption or Compton scattering and have rather long ranges in the emulsion. In fact, an electron produced in this way may react with many grains in the emulsion. The final result is to free electrons from the bromide ion, producing bromine atoms and an electron which can move to a trapping site and begin the process of latent-image formation. The energy of one absorbed X-ray photon can produce thousands of silver atoms at latent image sites in one or several grains. Even this number of silver atoms is low considering the energy of absorbed photon. Most of the energy of the absorbed photon is lost in processes which do not produce any photographic effect (such as losses to gelatin). Only 3 to 10 %

of the photon energy is used to produce photolytic silver.(7)

The sensitivity of film to direct X-ray exposure varies markedly (by a factor of 20 to 50) with the energy ( $kV_p$ ) of the X-ray beam. This X-ray spectral sensitivity is most important when considering use of film to measure X-ray exposure dose; i.e., film badge monitoring. Above 50  $kV_p$ , the efficiency with which absorbed X-ray photons are utilized to produce a photographic effect decreases significantly with increasing photon energy. At about 50  $kV_p$ , the average KeV of the X-rays produced will be close to the K - shell binding energy of silver (25.5 keV) and bromine (13.5 keV). This will cause the film to exhibit maximum photoelectric absorption of 50  $kV_p$  X-rays. Figure 2.5 shows, in a rough graphic form, the way in which the X-ray sensitivity of film varies with  $kV_p$ .

The sensitivity also varies greatly with the way in which the film is developed. The amount of blackening (density) on the developed film may be used as an indication of how much X-ray exposure (i.e., how many milliroentgens) the film has received. However, because the sensitivity of the film varies greatly with the energy ( $kV_p$ ) of the X-rays, blackening of a simple piece of film does not give an accurate estimation of the exposure to which the film has been subjected. For example, a film subjected to an exposure of

50 mR at an X-ray energy of 50 kV<sub>p</sub> will, after development exhibit a much higher density (amount of blackening) than will an identical film subjected to an exposure of 50 mR by 200 KV<sub>p</sub> X-rays. The problem of variation of film sensitivity with radiation energy is partially solved by placing various metal filters in front of the film in an attempt to control the energy (kV<sub>p</sub>) of the X-rays which reach different areas of the film. The accuracy of film badge monitoring of X-ray exposure is about  $\pm$  20%. Film badge monitoring of personnel exposure offers several advantages over other methods, such as ionization chambers. The film badge provides a permanent record, it is small in size and weight; rugged and inexpensive. (2,7)

### Supercoating

Covering the emulsion is a thin layer, commonly gelatin, which serves to protect the emulsion from mechanical damage. In special types of film this supercoat, or antiabrasive coating, may contain substances which make the film surface smooth and slick. This is a desirable quality in film which must be transported through a cut-film rapid film changer. (3)

## 2.2. FILM PROCESSING

### 2.2.1. DEVELOPMENT

Development is a chemical process which amplifies the latent image by a factor of millions (about 100,000,000) to form a visible pattern of silver. The basic reaction is reduction (addition of an electron) of the silver ion which changes it into black metallic silver. (5,6)



The developer is the reducing agent. Development is generally an all or none phenomenon; an entire grain is developed (reduced) once the process begins. The process is usually initiated at the site of a latent image speck (commonly on the surface of the grain). It is believed that the action of the silver atoms in the latent image is to accelerate (catalyze) the reduction of the silver ions in the grain by the developing chemicals. The silver in a grain which does not contain a latent image can be reduced by the developer, but at a much slower rate. Thus, time is a fundamental factor in the developing process. Development should be discontinued when the differential between exposed, developed grains and unexposed, undeveloped grains is at a maximum.

The developing solution contains two developing

agents, either hydroquinone and metol or hydroquinone and phenidone. Two agents are used because of the phenomenon of synergism, or super additivity. The mixture results in a development rate greater than the sum of the developing rate of each developing agent. Recently the hydroquinone-phenidone combination has become more important because the speed of this combination is of value in rapid (90 sec.) processing of film. The reasons for development synergism are complex and not fully understood, so we will not explore the details.

The developing agent reduces silver ions to metallic silver, causing oxidation and inactivation of the developing agent and the liberation of hydrogen ions. See Figure 2.6 as an example.

Notice that the reaction must proceed in an alkaline solution. When hydroquinone is oxidized to quinone, two electrons are liberated to combine with the two silver ions to form metallic silver. The reaction of phenodine is similar (see diagram). (Figure 2.6)

The silver which is formed is deposited at the latent-image site, gradually enlarging this initially microscopic black spot into a single visible black speck of silver in the emulsion.

In addition to developing agents (metol, hydroquinone-phenodine, glycin, pyro-catechin amidol, paraphenylene nedia-

mine), the developing solution contains;

1) an alkali to adjust the pH and speed up development

(Sodium carbonate, potassium carbonate, Borax, Sodium hydroxide, Potassium hydroxide)

2) a preservative (sodium sulfite) and

3) restrainers, or antifoggants (Potassium bromide)

The alkali adjusts the hydrogen ion concentration, which greatly affects the developing power of the developing agents, especially hydroquinone. In addition, the alkali serves as a buffer to control the hydrogen ions liberated during the development reaction. Most radiographic developers function at a pH range of 10.0 to 11.5.

Sodium sulfite is added for two reasons. The oxidation products of the developing agents decompose in alkaline solution and form colored materials which can stain the emulsion. These products react rapidly with sodium sulfite to form a colorless, soluble substance. In addition, sodium sulfite acts as a preservative. In alkaline solution, the developing agent will react with oxygen from the air. The sulfite acts as a preservative by decreasing the rate of oxidation, especially of hydroquinone. (7)

Fog is defined as the development of unexposed silver halide grains which do not contain a latent image. In a complex manner, dilute concentrations of soluble bromide (potassiumbromide) decrease the rate of fog formation. To a lesser degree the bromide also decreases the rate of development of the latent image. Phenodine is not as sensitive to bromide concentration as metol. With phenodine developers an organic restrainer must also be added to prevent the developing of unexposed grains by this active developing agent.(6)

The bromide ions released by the reduction of silver ions to silver atoms pass into the developing solution. In large part, it is this increase in bromide concentration that limits the life of developing solutions.

#### 2.2.2. REPLENISHMENT

We have seen that, during use, developing solutions consume developing agents and preservatives, but acquire hydrogen ions and bromide ions. Replenishing solutions which are used to maintain the activity of the developer must be free of bromide, contain alkaline agents and buffers, and to a lesser extent, restore depleted preservative, and developing agents.

Practically, for manual processing for each  $1 \text{ m}^2$  film, we need 0.4 lt. of replenisher. For automatic proces-

sing for  $1\text{m}^2$  film, we need 0.6 lt. of replenisher.

As the composition of the developers could be different, we must replenish with the adapted replenisher.

Usually, the formula is as follows;

1 part concentrated + 5 parts of water = DEVELOPER

1 part concentrated + 3 parts of water = REPLENISHER

### 2.2.3. FIXING

Only part of the silver halide in the emulsion is reduced to silver during developing. The remaining silver halide impairs both the immediate usefulness and permanence of the developed radiograph. Therefore, it must be removed, but the fixing solution must remove silver halide without damaging the image formed by metallic silver.

The solubility of silver halide (use silver bromide as an example) in a water solution is controlled by the concentration of silver and halide ions. Silver bromide is only slightly soluble in water. The product of the silver and bromide ions in solution is always constant for any given temperature and may be expressed by the equation:

$$\text{Silver ion} \times \text{Bromide ion} = \text{constant}$$

If the concentration of silver ions could be reduced, the concentration of bromide ions would have to increase, which means that more silver bromide would have to dissolve from the emulsion. Thus, the solubility of silver halide would increase. The function of the fixing agent is to form water-soluble complexes in which silver ions are tightly bounded. The soluble complex so formed effectively removes silver ion from solution.

Two agents form satisfactory stable complexes with silver ions: cyanides and thiosulfates. Cyanides are poisonous and not generally used. Thiosulfate in the form of the sodium or ammonium salt is the common fixing agent or "hypo". In earlier chemical nomenclature, the compound we call sodium thiosulfate ( $\text{Na}_2\text{S}_2\text{O}_3$ ) was given the name hypo sulfite of soda, and "hypo" it remains to photographers. At least three silver thiosulfate complexes are formed in the fixing solution; their identities need not concern us. (4)

A typical reaction might be:



The ammonium thiosulfate salt is the more active and is used in fixer supplied as a liquid concentrate.

In addition to thiosulfate, the fixing solution contains a substance to harden the gelatin. Hardening results in a decrease in the swelling of gelatin, making it tougher and more resistant to abrasion. The hardener is usually a chromium or aluminum compound. The fixing bath also contains an acid, stabilizers, and a buffer to maintain the acid pH level.

An incompletely fixed film is easily recognized because it has a "milky" or "cloudy" appearance. This is a result of the dispersion of transmitted light by the very small silver iodo-bromide crystals which have not been dissolved from the emulsion.

#### 2.2.4. WASHING

After developing and fixing, the film must be well washed in running water. Washing serves primarily to remove the fixing-bath chemicals. Everyone has seen an X-ray film which has turned brown with age. This is the result of incomplete washing. Retained hypo will react with the silver image to form brown silver sulfide, just as silverware acquires a brown tarnish when exposed to the hydrogen sulfide produced by cooking gas. (2)

The general reaction is:

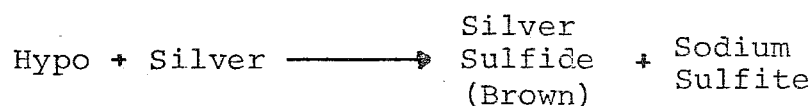

#### 2.2.5. DRYING

The films are dried after final washing. The emulsion and back become hard and the radiograph is ready for further use.

Regular drying by air is to be preferred. If a drying cabinet is used for more rapid drying, care should be taken that the temperature of the circulating air does not exceed 40°C and that the relative humidity of the air is between 50 and 60 %. (7)

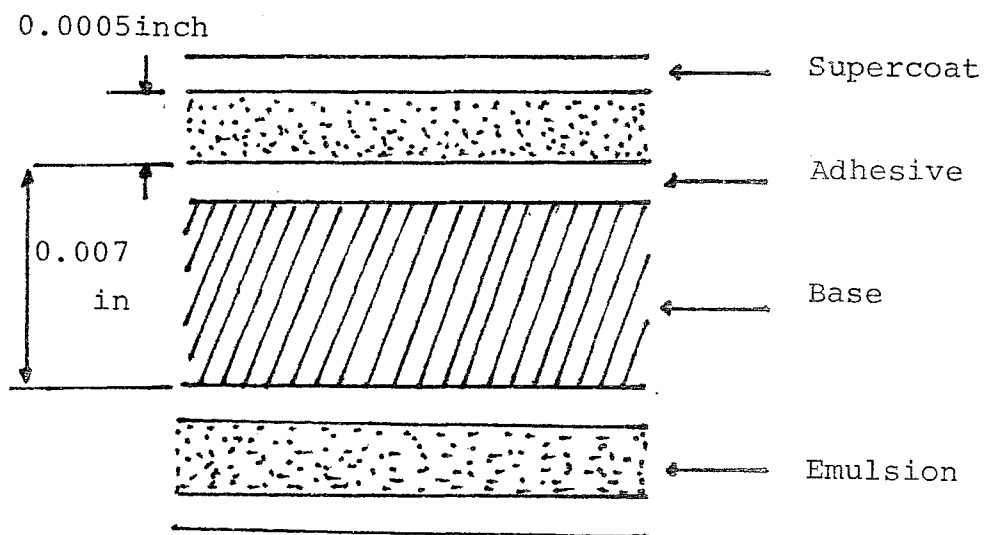

Figure 2.1: Cross section of a double emulsion X-ray film.

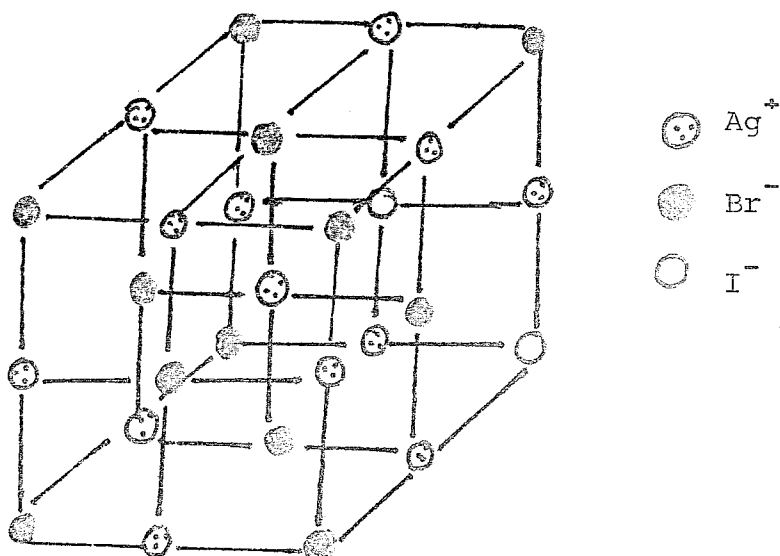

Figure 2.2: The silver iodo-bromide crystal lattice

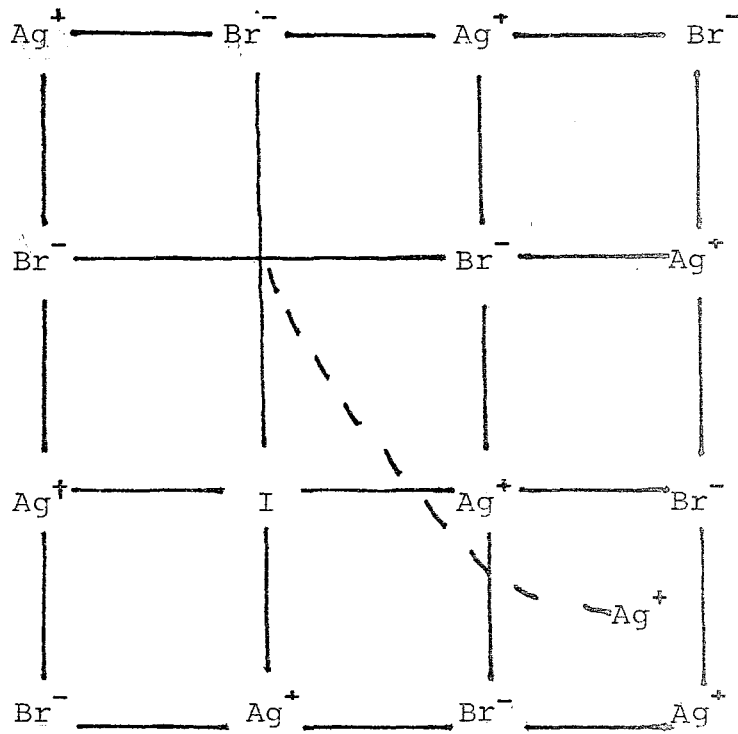

Figure 2.3 : A point defect

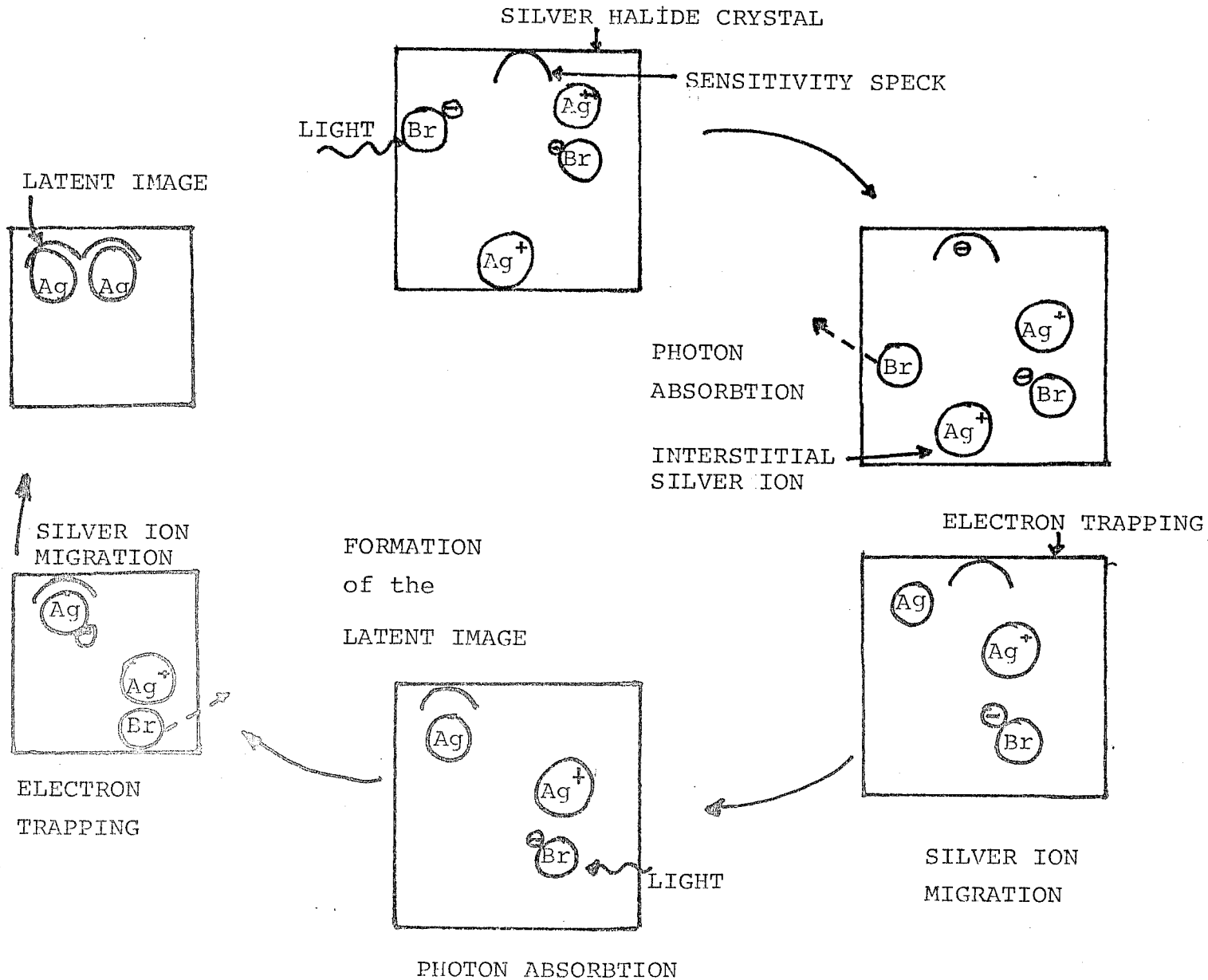

Figure 2.4 : Formation of the latent Image

RELATIVE FILM SENSITIVITY

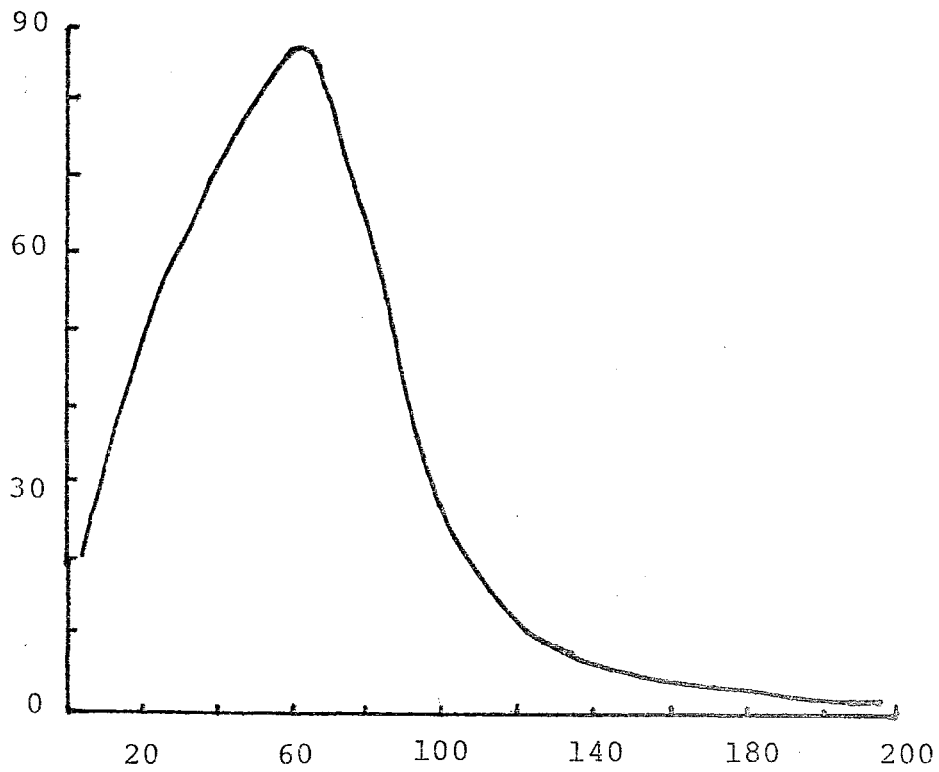

Figure 2.5 : Film sensitivity varies with radiation quality.

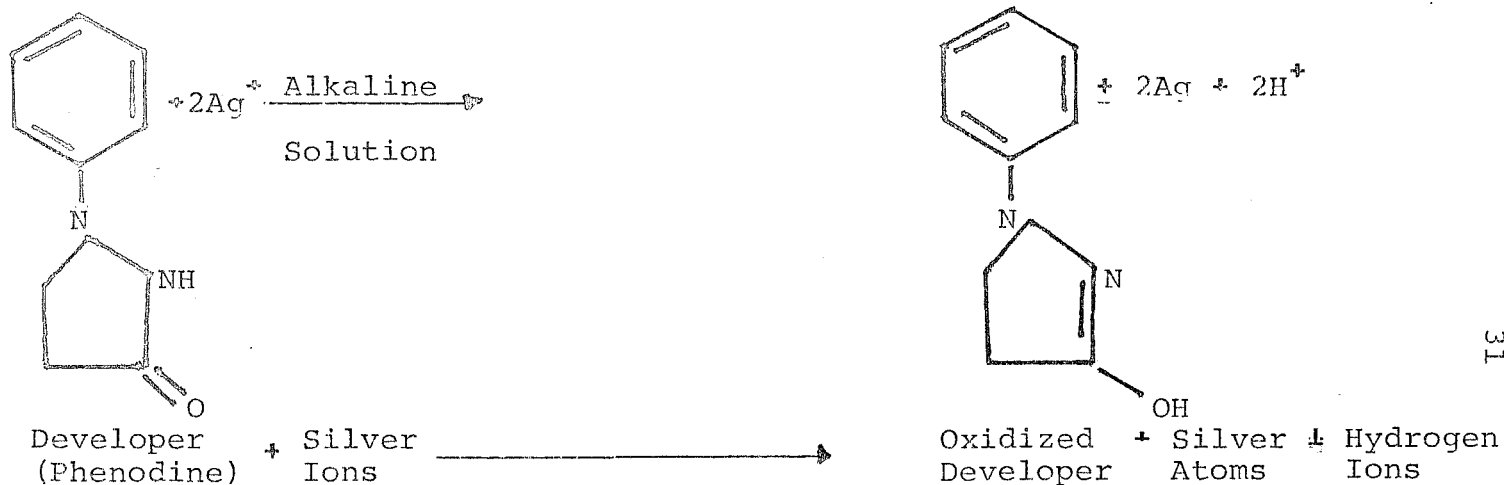
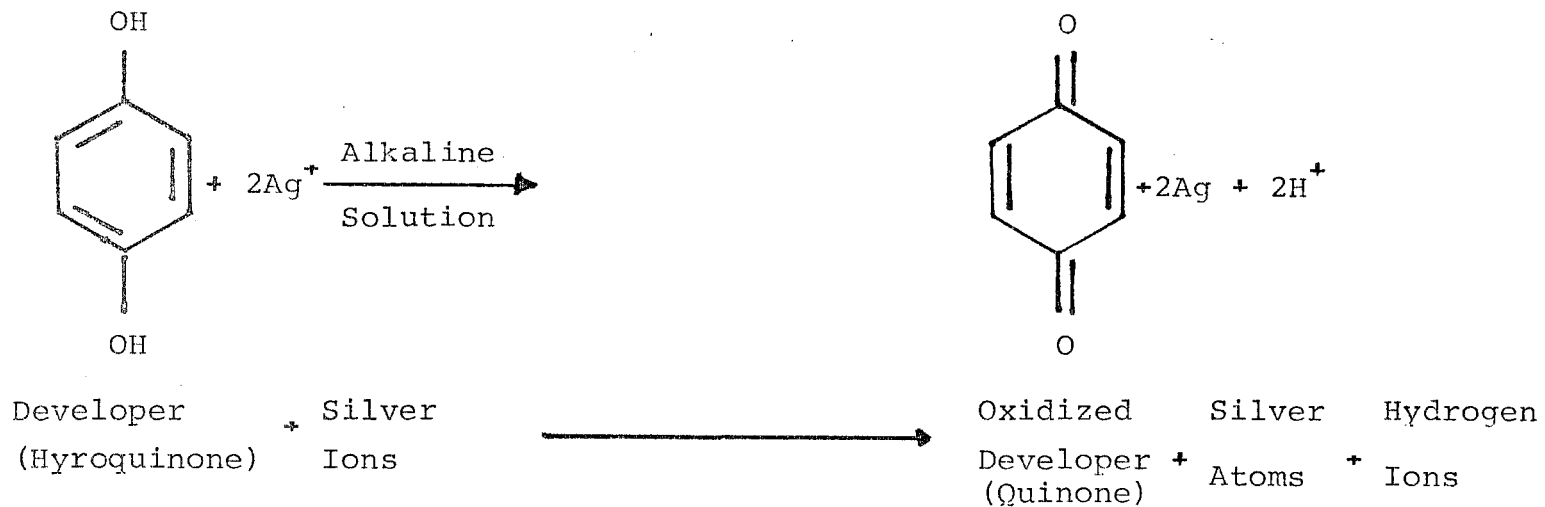

Figure 2.6:

CHAPTER II.REFERENCES

1. Baines, H., and Bomback, E.S.: "The Science of Photography"  
2nd ed. London: Fountain Press, 1967.
2. Fuchs, A.W.: "Evolution of Roentgen Film". Amer. J. Roentgen.  
75, 30, 1956.
3. James, T.H., and Higgins, G.C.: "Fundamentals Of Photographic Theory", 2nd ed. New York: Morgan and Morgan ,  
Inc. 1968.
4. E.E. Christensen, T.S. Curry, J.E. Dowdey.: "An Introduction To The Physics Of Diagnostic Radiology" 2nd Edition.  
Lea and Febiger. Philadelphia, 1978.
5. Martin, F.C., and Fuchs, A.W.: "The Historical Evaluation Of Roentgen-Ray Plates And Films". Amer. J. Roentgen.  
26, 540, 1931.
6. Mees, C.E.K., and James, T.H.: "The Theory Of The Photographic Process" 3rd ed. New York: The Macmillian Co., 1969.
7. Neblette, C.B.: "Photography, Its Material And Process".  
6th ed. New York: Van Nostrand, 1962.

CHAPTER III.PHOTOGRAPHIC CHARACTERISTICS OF X-RAY FILM3.1. INTRODUCTION

The diagnostic accuracy of a radiographic film examination depends, in part, on the visibility of diagnostically important information on the film. Understanding the relationship between the exposure a film receives and the way the film responds to the exposure is essential to intelligent selection of proper exposure factors and type of film to provide maximum information content of the radiograph.

Exposure (mAs) of the X-ray film produces film blackening, or density. The quality of the X-ray beam ( $kV_p$ ) has more effect on image contrast. Two general, but not completely accurate, statements should be kept in mind (7):

---

mAs controls film density  
 $kV_p$  controls image contrast

---

In this chapter we will discuss the response of the X-ray film to exposure.

### 3.2. PHOTOGRAPHIC DENSITY

When the X-ray beam passes through body tissues, variable fractions of the beam will be absorbed, depending on the composition and thickness of the tissues and the quality ( $kV_p$ ) of the beam. The magnitude of this variation in beam intensity is the mechanism by which the X-ray beam acquires the information which it transmits to the film. This pattern of varying X-ray intensity has been called the X-ray image. Webster's Collegiate Dictionary defines an image as "a mental representation of anything not actually present to the senses". This definition is particularly applicable to the idea of X-ray image. The X-ray image is present in the space between the patient and the X-ray film (or X-ray intensifying screen). The information content of the X-ray image must be transformed into a visible image on the X-ray film with as little loss of information as possible. The measurement of film blackness is called photographic density. Photographic density is defined by an equation: (2)

$$D = \log \frac{I_o}{I_t}$$

Where  $D$  is density,  $I_o$  is light incident on a film and  $I_t$  is light transmitted by the film. Refer to Figure 3.1. Note that  $\frac{I_o}{I_t}$  measures the opacity of the film (the ability

of film to spot light). The reciprocal of density,  $\frac{I_t}{I_o}$  measures the fraction of light transmitted by the film and is called transmittance. Useful densities in diagnostic radiology range from about 0.3 (50 % of light transmitted) to about 2 (1 % of light transmitted). A density of 2 means that  $\frac{I_o}{I_t} = 2$ . Since the log of 100 = 2,  $\frac{I_o}{I_t} = 100$ . Thus, for every 100 light photons incident on the film, only 1 photon, or 1 %, will be transmitted. (8)

Table 3.1 lists some common values for opacity ( $\frac{I_o}{I_t}$ ) density ( $\log \frac{I_o}{I_t}$ ), and the percent of light transmission.

Table 3.1. Percentage of Light Transmitted by X-Ray Films of Various Densities.

OPACITY $\frac{I_o}{I_t}$	DENSITY $\log \frac{I_o}{I_t}$	PERCENT OF LIGT TRANSMITTED
1	0	100
2	0.3	50
4	0.6	25
8	0.9	12.5
10	1.0	10
30	1.5	3.2
100	2	1
1000	3	0.1
10000	4	0.01

Note that an increase in film density of 0.3 decreases transmitted light to one-half its previous value. For example, an increase in density from 0.6 to 0.9 decreases the percent of transmitted light from 25 to 12.5 %. This emphasizes the fact that the number used to signify a certain density has no units, but is a logarithm. The number 0.3 is the logarithm of 2. Thus, an increase in density of 0.3 ( $\log \frac{I_o}{I_t}$ ) means an increase in opacity ( $\frac{I_o}{I_t}$ ) of 2; opacity is  $\frac{I_o}{I_t}$  doubled by a density increase of 0.3.

If an unexposed X-ray film is processed, it will demonstrate a density of about 0.12. This density consists of base density and fog. The plastic material used to make the film base absorbs a small amount of light. Also, the blue dye used to color some film base adds slightly to base density. Total base density will average about 0.07. A few of the silver halide grains in an X-ray film emulsion develop without exposure. These unexposed, but developed, grains comprise the density known as fog. Fog density of a fresh X-ray film averages about 0.05. (1,7)

Why is density expressed as logarithm? There are three primary reasons. First, logarithms conveniently express large differences in numbers on a small scale.

Second, the physiological response of the eye to differences in light intensities is logarithmic. (Figure 3.2)

Assume that a film having regions of density which equal 0.3, 0.6 and 0.9 is transilluminated by a light source of 1000 photons. The number of light photons transmitted will be 500, 250, and 125 respectively. The difference in transmitted light photons between density 0.3 and density 0.6 is 250 (500 to 250), but between density 0.6 and density 0.9 is only 125 photons (250 to 125).

However, the eye will interpret density 0.3 as being exactly as much brighter than density 0.6, as density 0.6 is brighter than density 0.9. The eye has "seen" the equal differences in density rather than the unequal differences in the number of light photons transmitted.

The third reason for expressing density as a logarithm deals with the addition or superimposition of densities. If films are superimposed, the resulting density is equal to the sum of the density of each film. Assume two films, one of density 2 and one of density 1, which are superimposed and put in the path of light source with an intensity of 1000 units (Figure 3.3).

The film of density 1 absorbs 90 % of the light (100 units are transmitted) and the film of density 2 absorbs 99 % of these 100 units to finally allow 1 unit of light to be transmitted. We may calculate the density

$$D = \log \frac{I_o}{I_t} = \log \frac{1000}{1} = 3$$

With double - emulsion films, the total density exhibited by the radiograph is the sum of the density of each emulsion.(2,8).

### 3.3. CHARACTERISTIC CURVE

It is necessary to understand the relationship between the exposure a film receives and the density produced by the exposure. The relation between different exposures and different degree of blackness (density) caused thereby is expressed most clearly by means of a curve, called "characteristic curve" (also "density curve", "gradation curve" or "D/log E curve"). It may also called H and D curve (named after F. Hurter and V.C. Driffield, who first published such a curve in England in 1890). This curve is obtained by applying increasing exposures to a series of successive areas of a strip of emulsion (on film, plate or paper), each of which exposures is equal to the preceding one multiplied by a constant. After development, the densities (D) are measured by means of a densitometer and then plotted against the logarithmic values of the corresponding exposures (log E).(4,8)

The points obtained are then joined together by a continuous line (Figure 3.4). Note that an increase in the log relative exposure of 0.3 always represents a doubling of the relative exposure.

Analysis of the characteristic curve of a particular X-ray film will give us information about the contrast, speed (sensitivity), and latitude of the film. First, note the following in Figure 3.5. Even at 0 exposure, the film density is not 0, but will usually be 0.2 or less. This density is made up by fog (development of unexposed grains of silver halide in emulsion) and base density (opacity of film base) which have been previously discussed. Therefore, total density on an exposed and developed film will include base and fog density. The minimum density caused by base and fog in a "fresh" film is about 0.12. To evaluate density produced by the exposure alone, one must subtract base and fog density from the total density. Second, note that at low density (toe) and at high density (shoulder), the film shows little change in density despite a relatively large change in log relative exposure (Figure 3.5). The important part of the characteristic curve is between the toe and shoulder, and in this region the curve is almost a straight line. In this "straight line" portion, the density is approximately proportional to the log relative exposure. For example, if log relative exposure 1.1 produces a density of 1.0, and log relative exposure 1.3 produces a density of 2.0, we can predict that a density of about 1.5 will be produced by log relative exposure of 1.2.

### 3.3.1. FILM CONTRAST

The information content of the invisible X-ray image is "decoded" by the X-ray film into a pattern of variations in optical density, or radiographic contrast. Radiographic contrast is the density difference between image areas in the radiograph. Radiographic contrast depends on subject contrast and film contrast. Subject contrast depends on the differential attenuation of the X-ray beam as it passes through the patient. Subject contrast was seen to be affected by the thickness, density, and atomic differences of the subject; the radiation energy ( $kV_p$ ); contrast material; and scatter radiation. (4.7)

The information content of the X-ray image is the pattern of varying intensity of the X-ray beam caused by differential attenuation of X-rays by the subject. Through areas of bone or opaque contrast material, few X-rays reach the film, while many photons are transmitted through soft tissue, and the air around the patient stops almost no X-ray photons. The  $kV_p$  must be selected with care so that the numbers of photons attenuated by bone and soft tissue are in the proper proportion to produce an X-ray image of high information content for the film intensifying screen to "decode". The correct  $kV_p$  is tremendously important in producing proper subject contrast. Using the correct mAs causes the total number of X-rays in each part of the attenuated

X-ray beam to be sufficient to produce the correct film exposure, thus producing correct overall density in the processed film. Too little, or too much, mAs results in an underexposed or overexposed radiograph. Film contrast depends on four factors: (2)

1. Characteristic curve of the film
2. Film density
3. Screen or direct X-ray exposure
4. Film processing.

#### Characteristic Curve:

The shape of the characteristic curve tells us how much change in film density will occur as film exposure changes. The slope, or gradient, of the curve can be measured and expressed as a number is called film gamma. This gamma of a film is defined as the maximum slope of the characteristic curve, and is described by the formula:

$$\text{Gamma} = \frac{D_2 - D_1}{\log E_2 - \log E_1}$$

where  $D_2$  and  $D_1$  are the densities on the steepest part of the curve resulting from log relative exposures  $E_2$  and  $E_1$  (Figure 3.6)

In radiology, since the steepest (maximum slope) portion of the characteristic curve is usually very short, we are interested in the slope of the curve over the entire range of useful radiographic densities ( 0.25 to 2.0) The slope (gradient) of a straight line joining two points of specified density on the characteristic curve is called the average gradient. The average gradient is usually calculated between density 0.25 and 2.0 above base and fog for radiographic films. Such a calculation is shown in Figure 3.7, which is the same curve as in Figure 3.6. (4)

If the average gradient ( $\bar{G}$ ) of the film used is greater than 1, the film will exaggerate subject contrast, and the higher the average gradient, the greater this exaggeration will be. A film with  $\bar{G}$  of 1 will not change subject contrast; a film with an average gradient of less than 1 will decrease subject contrast. Since contrast is very

important in radiology, X-ray films all have an average gradient of greater than 1.

### Density:

The slope of the characteristic curve (i.e. film contrast) changes with density. This is especially true in the toe and shoulder regions (Figure 3.4). Let us consider an X-ray study of the abdomen in which the  $kV_p$  chosen results in one area transmitting about 1.6 times more radiation than another. This means a log relative exposure difference of 0.2 ( $\log 1.6 = 0.2$ ). We will assume that the film used for this study has the characteristic curve depicted in Figure 3.8.

If factors of time, milliamperes, and focus-film distance are correct, the log relative exposures will produce film density falling along the steep portion of the characteristic curve. This will produce a density difference (radiographic contrast) of 0.6, or difference in light transmission of 4:1 ( $\text{antilog } 0.6 = 4$ ). However, if the exposure puts the developed densities on the toe of the curve, the film is underexposed (not enough mAs), and the density difference will fall to 0.13 or a difference in light transmission of 1.35 to 1 ( $\text{antilog } 0.13 = 1.35$ ). Note that the exposure ratio has remained the same (i.e., log relative exposure difference of 0.2) because the  $kV_p$  has not been changed. Similarly, overexposure, or too much mAs, will re-

sult in densities in the shoulder region of the characteristic curve of our hypothetical film-screen combination. As diagrammed in Figure 3.8, this will result in a density difference (contrast) of 0.2, corresponding to a difference in light transmission of 1.59 to 1 (antilog 0.2 = 1.59). Exposures producing density at the level of 3 (0.1 % of light transmitted) also produce less visible contrast under ordinary viewing conditions because the human eye has low sensitivity to contrast at low brightness levels. This is why a spotlight must be used to aid in viewing regions of high density. (2)

#### Screen or Direct X-Ray Exposure:

If a film designed for exposure by light from intensifying screens is exposed to X-rays directly, its characteristic curve has a considerably different shape than the curve obtained from exposure with screens. Considerably more exposure (mAs) is required if no screens are used, since the intensification factor of screens may range from about 15 to 50 or more. Films exposed with par speed intensifying screens will require an X-ray exposure of approximately 1 mR to produce a density of 1 ; this value will rise to 30 mR or more with direct X-ray exposure. (3,6)

At the same density, contrast is always lower for a film exposed

to X-rays only than for the same film exposed by light from intensifying screens. The reason for this difference in contrast is not precisely known. It probably is related to the complex manner in which the film emulsion responds to the energy of absorbed X-ray photons. In addition, intensifying screens are relatively more sensitive than film to higher energy X-rays. Stated another way, the average gradient of a double emulsion X-ray film will be greatest when the film is exposed with intensifying screens. Direct X-ray exposure will produce a lower average gradient. The photochemical reasons for this phenomenon are not known. (2)

#### Film Processing (Development):

Increasing the time and/or temperature of development will, upto a point, increase the average gradient of a film (film speed is also increased) (Figure 3.9 and 3.10). If development time is only 40 % of normal, the gradient will be reduced to 60 % of maximum. However, fog will also be increased with increased development time or temperature, and fog decreases contrast. For these reasons, it is important to adhere to the manufacturer's standards in processing film. Automatic film-processing equipment has eliminated some of the problems associated with temperature of solutions and development time. (9)

To summarize, increasing the time or temperature of

development will:

1. Increase average gradient (increase film contrast)
2. Increase film speed (increase density for a given exposure)
3. Increase fog (decrease film contrast)

#### 3.4. SPEED

While film contrast is a function of the shape of the curve, film speed (or sensitivity) determines the position of this curve with respect to the log exposure scale. The American Standards Association defines the speed as the reciprocal of the exposure in roentgens required to produce a density of 1.0 above base and fog densities.

$$\text{Speed} = \frac{1}{\text{Roentgens}}$$

The average X-ray film used with intensifying screens has a speed of about 800. Similarly, a film exposed to X-rays directly might require an exposure of  $2.2 \times 10^{-2}$  (22 mR) for the same density and its speed would be: (2,8)

$$S = \frac{1}{0.022 \text{ R}} = \frac{45}{\text{R}} = 45 \text{ R}^{-1}$$

The shape of the characteristic curve is controlled by film contrast; the film speed determines the location of the curve on the log exposure scale. Figure 3.11 shows the curves of two films which are identical except that film B is 0.3 log relative exposure units to the right of film A. Both films will show identical film contrast, but film B require twice ( $\text{antilog } 0.3 = 2$ ) as much exposure (mAs) as film A. Because the gradient of a characteristic curve varies with density, the relative speed between two films will be found to vary with the density at which speed is measured.

### 3.5. LATTITUDE

Unlike average gradient and speed, film latitude is not expressed in numerical terms. Latitude refers to the range of log relative exposure (mAs) which will produce density within the accepted range for diagnostic radiology. (usually considered to be density 0.25 to 2.0). Generally speaking, the latitude of a film varies inversely with film contrast.

a) Emulsion Latitude: If the correct exposure interval lies between  $\log E_1$  and  $\log E_2$ , the range of correct exposures-emulsion latitude - is equal to  $2^{-1}$  (log value), or 10:1 expressed on an arithmetical scale. In other words the brightest highlight striking the emulsion must not have more than ten times the deepest shadow brightness. As

the characteristics curves in Figure 3.13 shows, the exposure latitude of a high contrast emulsion (steep curve) is generally less than that of a softer emulsion.

b) Exposure latitude: Expressed logarithmically, exposure latitude is the difference of the range of correct exposures and the exposure range of the exposure image.

Example: If expressed in log values, the range of correct exposures of the emulsion (a, Figure 3.14) is 1.3 and the exposure range of the exposure image (b) is 0.7, exposure latitude (c) is  $1.3 - 0.7 = 0.6$ , expressed arithmetically, is the antilog of 0.6, i.e. 4:1. This means that, using the same aperture, the maximum correct exposure will be four times longer than the minimum one.

Expressed arithmetically, exposure latitude is the ratio of the emulsion latitude to the exposure range of the exposure image. If the emulsion latitude is 20:1 and the exposure range of the exposure image 5:1, the exposure latitude will be  $20:1 \times 1:5 = 4:1$ .

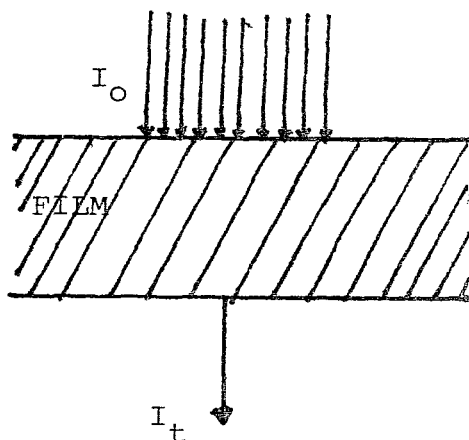

$$\text{DENSITY} = \text{LOG}_{10} \frac{I_0}{I_t}$$

Figure 3.1 : Photographic Density. Of  $I_0 = 10$  and  $I_t = 1$

$$\text{Density} = \log_{10} \frac{10}{1} = \log 10 = 1$$

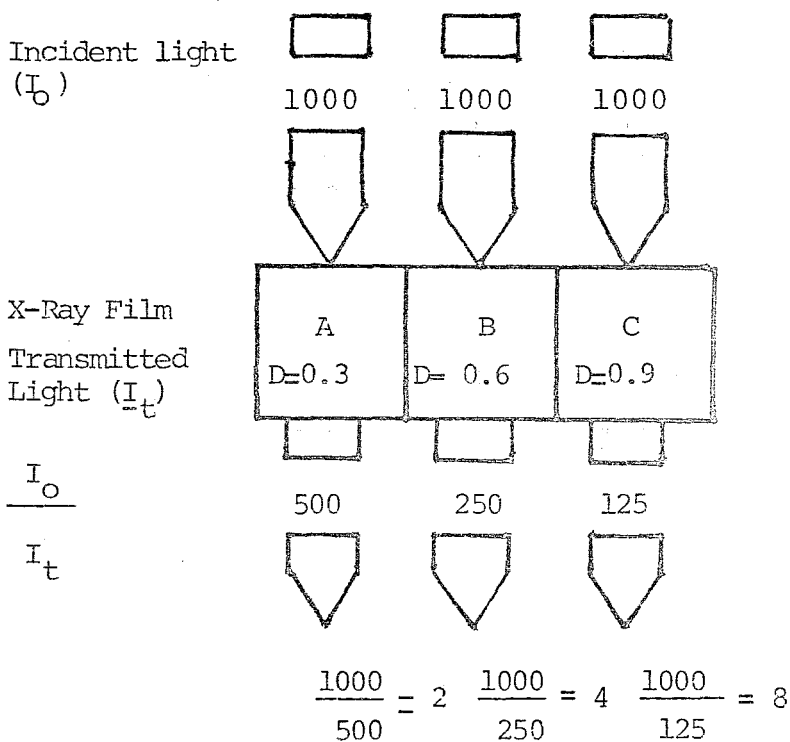

$$\log \frac{I_0}{I_t} = \text{DENSITY} \quad \log 2 = 0.3 \quad \log 4 = 0.6 \quad \log 8 = 0.9$$

Figure 3.2: The reduction in intensity caused by three films having

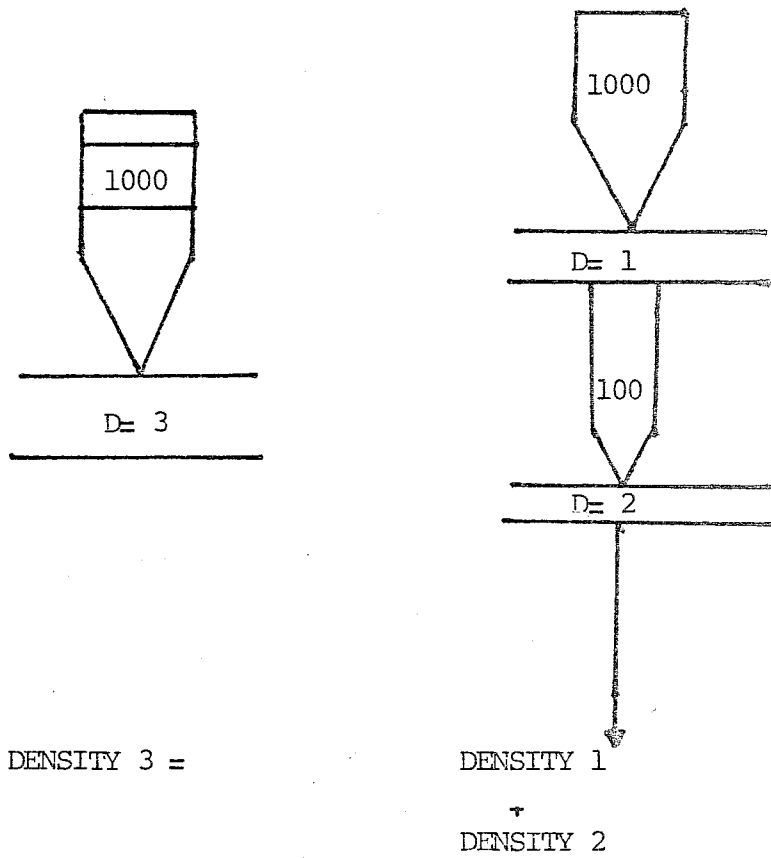

Figure 3.3 : The density of superimposed films is the sum of the density of the individual films.

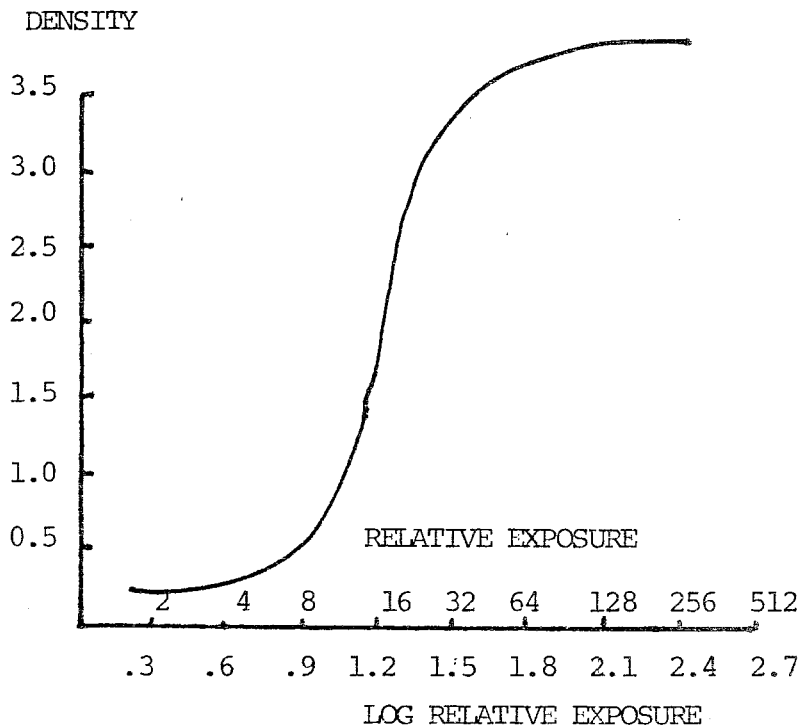

Figure 3.4 : The relationship between exposure and the corresponding log relative exposure

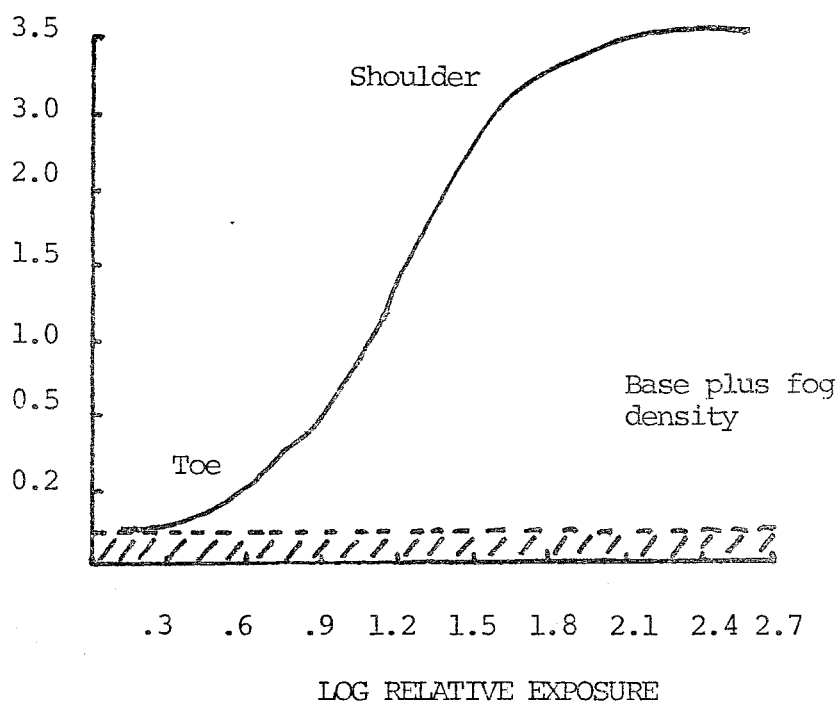

Figure 3.5 : The regions of the characteristic curve

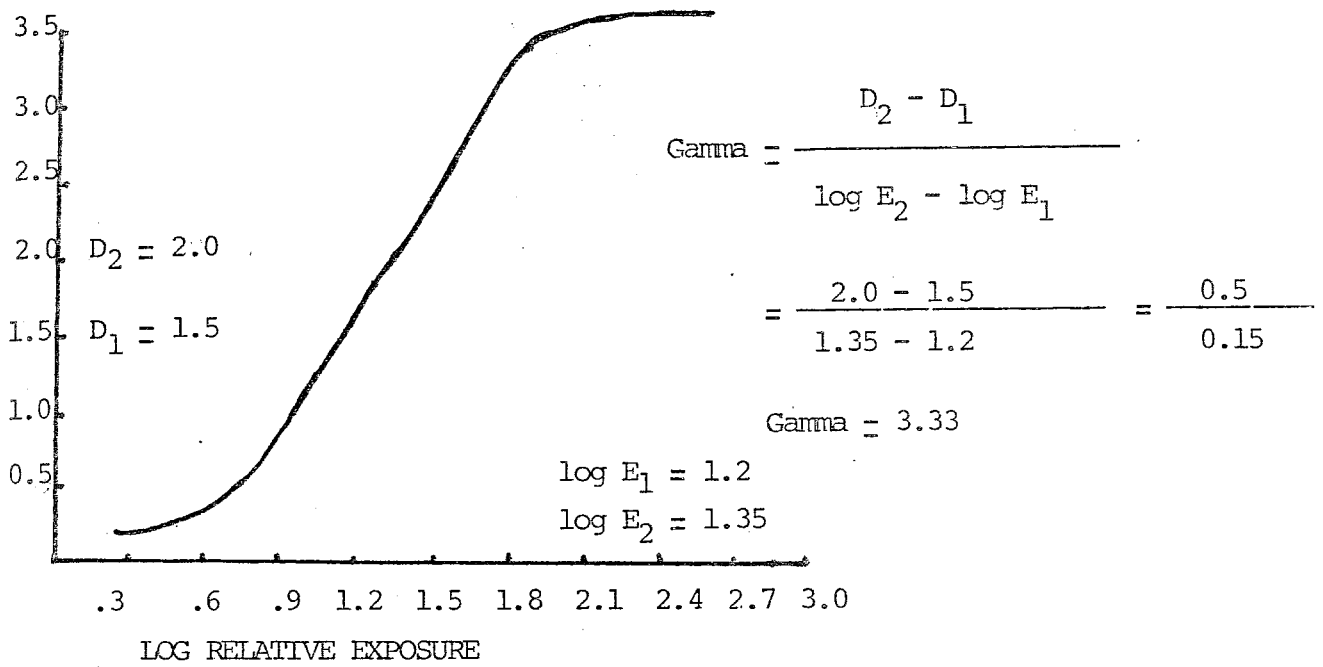

Figure 3.6 : The gamma of an X-ray film.

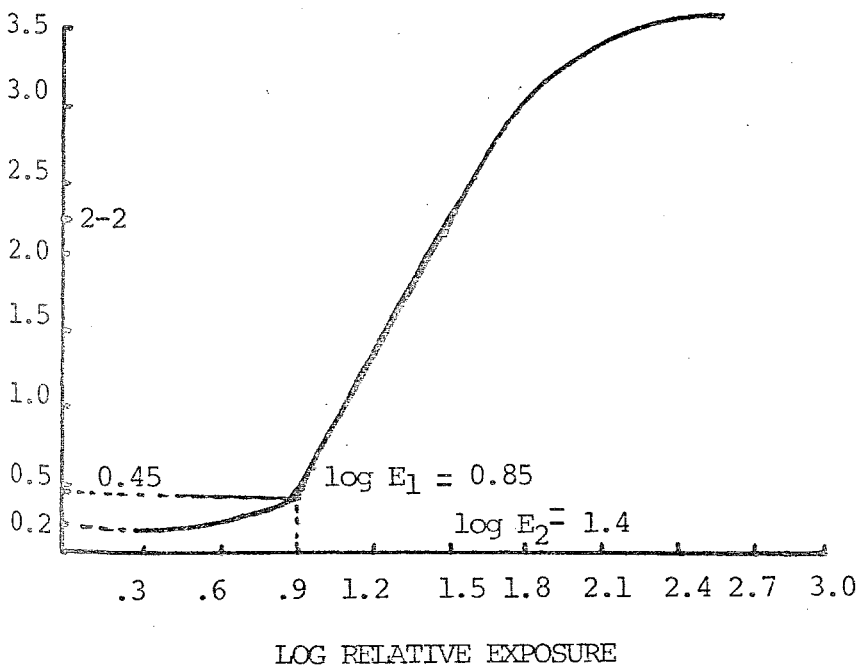

Figure 3.7 : The average gradient of an X-ray film.

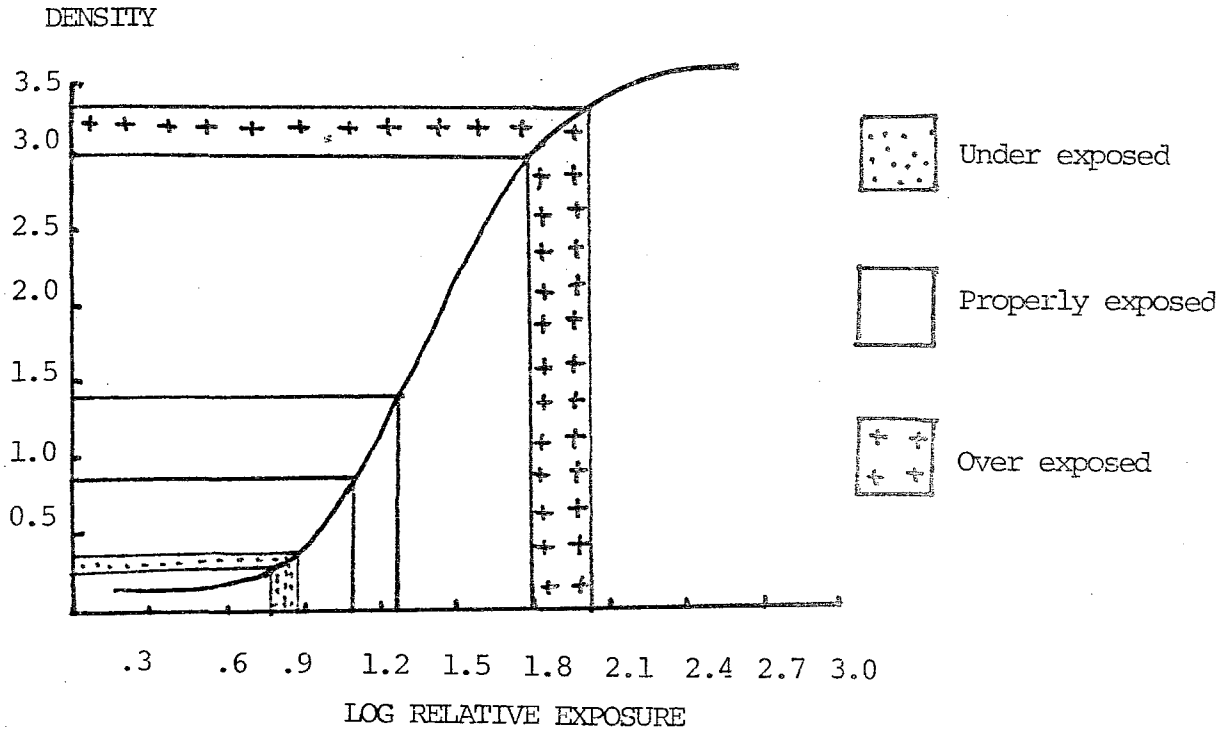

Figure 3.8 : Incorrect exposure result in loss of contrast

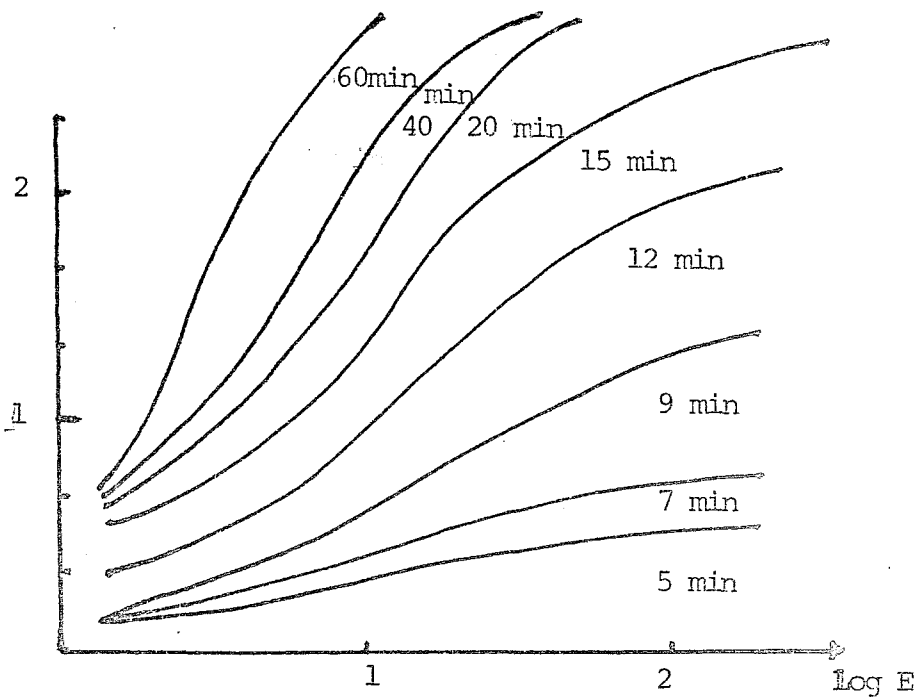

Figure 3.9 : Development time influences average gradient, speed and fog.

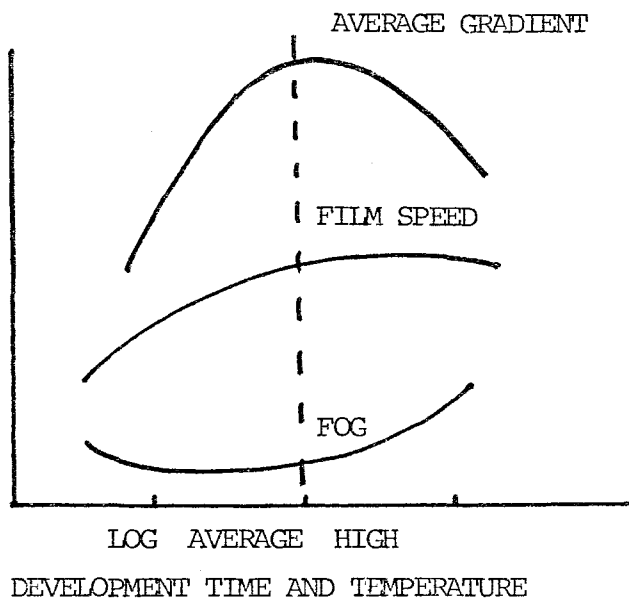

Figure 3.10 : Development time influences average gradient, Speed and fog.

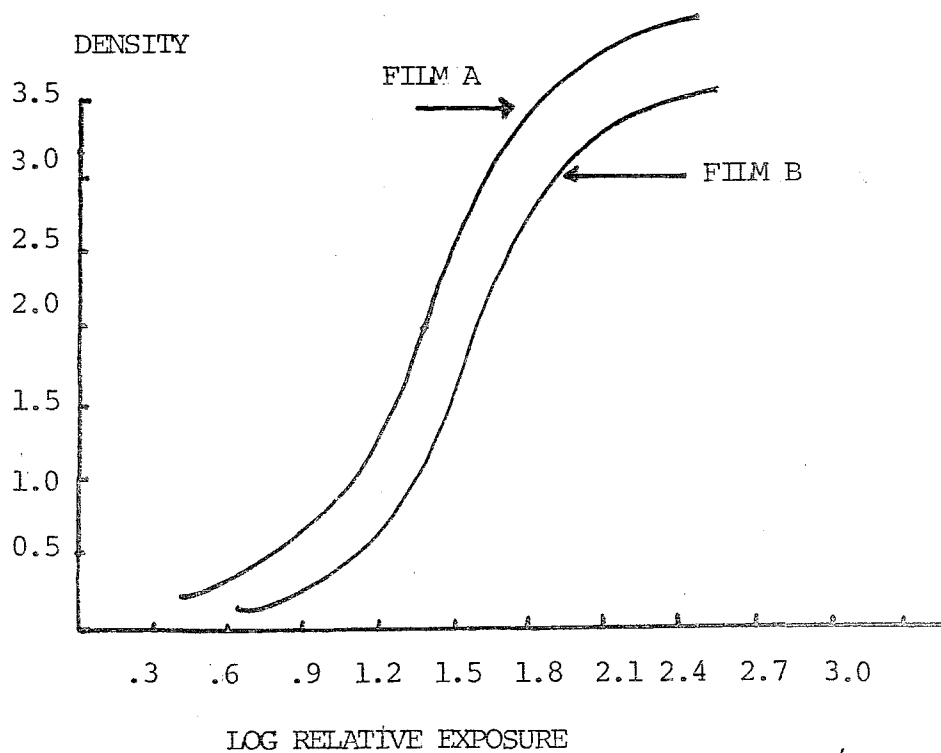

Figure 3.11: Film Speed

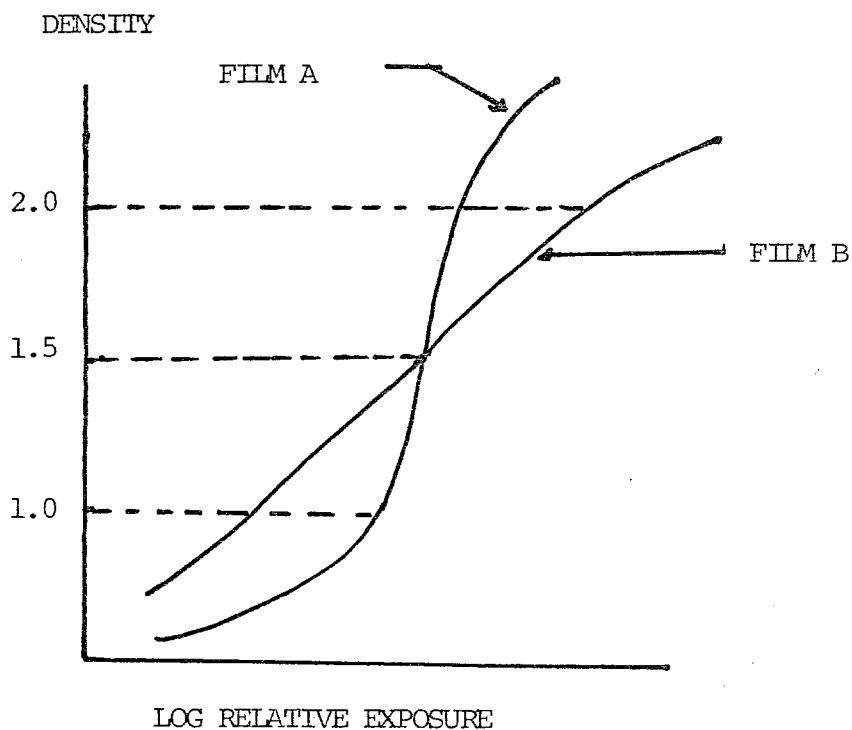

Figure 3.12 : Relative Film Speed varies with the density at which speed is measured.

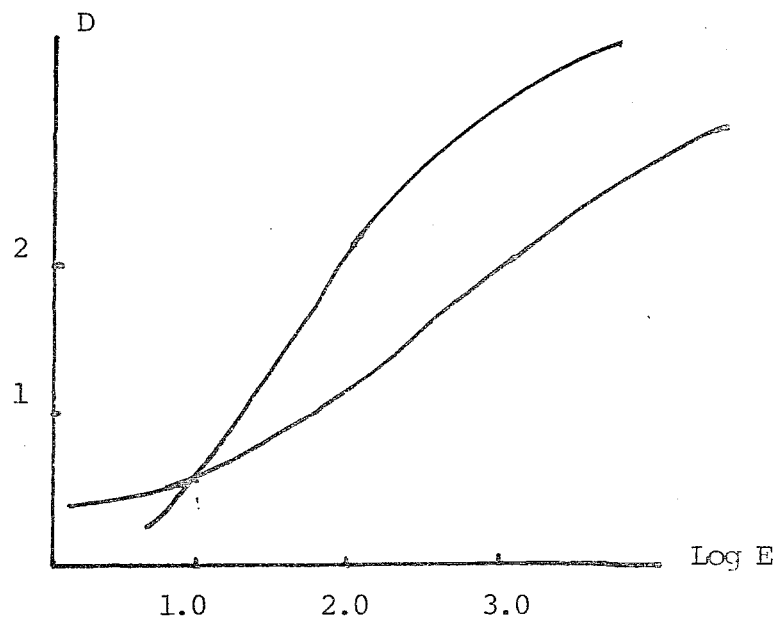

Figure 3.13 : Exposure latitude of a high contrast emulsion and that of a softer emulsion

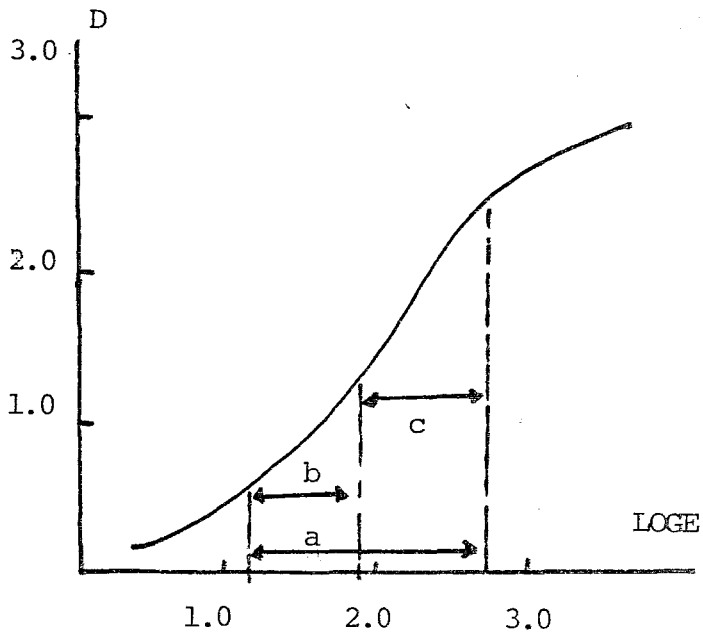

Figure 3.14 : Exposure latitude

CHAPTER III.REFERENCES

1. Bates, L.M.: "Some Physical Factors Affecting Radiographic Image Quality: Their Theoretical Basis And Measurement." Public Health Service, Publication No. 999-Rh-38, 1969.
2. E.E. Christensen, T.S. Curry, J.E. Dowday: "An Introduction To The Physics Of Diagnostic Radiology" 2nd ed. Lea and Febiger Philadelphia, 1978.
3. Lawrence, D.J.: Kodak X-OMATIC and LANEX screens and Kodak Films for medical radiography. Radiography Markets Division, Eastman Kodak Company File No. 5.03, June, 1976.
4. Meredith, W.J., and Massey, J.B.: "Fundamental Physics Of Radiology." Baltimore: Williams and Wilkins, 1968.
5. Ostrum, B.J., Becker, W., and Isard, H.J.: "Low - dose mammography". Radiol. 109, 323, 1973.
6. Presentation Script: "New Screen Technology". Prepared by Photo Products Department, E. I. du Pont de Nemours and Co.

7. Seeman, H.E.: "Physical and Photographic Principles of Medical Radiography. New York: John Wiley and Sons, Inc., 1968.
  
8. Sensitometric Properties of X-Ray Films. Rochester, N.Y.: Radiography Markets Division, Eastman Kodak Company .
  
9. Thompson, T.T.: "Selecting Medical X-Ray Film Part 1" Applied Radiol. 4,47, Sept/Oct., 1974.

## CHAPTER IV

### DARKROOM CONDITIONS AND DESIGN

#### 4.1. INTRODUCTION:

The role played by the processing room in the X-ray department is extremely important, for it is here that the latent image is turned into a clearly visible picture. Films that turn out gray, poor in contrast and otherwise unsatisfactory may be due to incorrect procedure in the processing room. A well-run processing room must meet the following requirements:

1. It must deal expeditiously with all films it receives;
2. It must provide optimum results;
3. It must have the best possible working-conditions.

#### 4.2. LIGHT FOG IN THE RADIOGRAPHIC DARKROOM

Fog may be an overall darkening of radiographic film or a slight additional exposure to the film that is not perceptible in the low density areas of the film but becomes more apparent with increasing density. It may be caused by overprocessing of radiographic films, especially in chemicals at an excessively high temperature, or it may be caused by

improper storage of the radiographic film before or after exposure in a heated area. Moreover, radiation leakage in the smallest quantities will fog film. However, our concern in this chapter will be with fog caused by improper safelight illumination in the darkroom or unsafe light in the darkroom.

Fog will affect the image quality of the radiograph BEFORE the fog is visually noticeable on the unexposed portions of the film.

The base-plus-fog level, or B+F, of the film is the density of an unexposed portion of the film after it has been processed and dried in the usual manner. The B+F is an important parameter which we will monitor to help detecting changes in the photographic processing conditions but radiographic image quality may be degraded before changes are noted in the base-plus-fog level of the film.

The effect of radiographic film fog may manifest in different ways. The most noticeable effect is usually a decrease in overall contrast of the radiograph. This is often compensated for by decreasing the  $kV_p$  to increase the radiographic contrast so that the resultant radiograph appears normal. The amount of light fog from the darkroom on film may be variable from sheet to sheet. As a result it may be necessary to decrease the technique by 5  $kV_p$  on one film to compensate for light fog while it may be necessary to decrease the technique from 2 to 10  $kV_p$  on the following film

to produce the same radiographic quality. As a consequence of light fog, the contrast will vary from film to film and the quality of films will be just as variable. In addition, and more importantly, the reduced  $kV_p$  used to compensate for reduced contrast will lead to an increased radiation dose to the patient.

The speed of radiographic materials usually increases with increasing fog exposure. Therefore, in addition to variability in contrast which may be compensated for by changes in  $kV_p$ , a change in overall density will become apparent requiring compensation in mAs to produce suitable films.

The best safelights improperly used will cause fog on radiographs. Normally, the manufacturer recommends a specific safelight filter with a 15-watt bulb at a distance of no less than 4 feet (122 cm). If you are using the safelights at other than these recommended conditions, the first step in checking out the darkroom is to follow the manufacturer's recommendations. In addition, since the safelight filters will fade over a period of time depending on conditions of use, it will be necessary to check the safelight conditions in your darkroom prior to optimizing your processing and again, at least, on an annual basis.

A major improvement may be made in the visibility in a darkroom by one simple procedure-painting the walls white

and covering the counter tops with a white or very light colored material. If the conditions specified by the manufacturer for safelight illumination are met, the addition of white walls and counter tops will not cause fogging of the radiographic films. It will, however, make it much easier to see in the darkroom since you will be looking at an object against a light background instead of a black or dark colored background. It will also make the darkroom appear much more pleasant and cheerful while making cleaning and maintenance easier.

What about "unsafe" light in the darkroom? If you go into the darkroom for about 10 minutes with all safelights and indicator lights turned off, you may be surprised how bright your darkroom really appears. Remember, if your eye can see it, it will fog the film, unless it is indeed a safelight. With the safelights still off, look for the following possible sources of unsafe light: indicator lights on processors and electronic controls; Light leaks around the doors and the processor; Light leaks through perforated or acoustical ceiling tile ( a common source of Light fog normally overlooked); Light emitted from luminous dials of timers; Light from cigarettes and various other sources. Once the sources of unsafe light in your darkroom have been eliminated, you are ready to see if your darkroom really meets the film fog test.

#### 4.3. HOW TO PROPERLY MEASURE FOG

A simple method of checking the safety of illumination is as follows: Make a short exposure, using intensifying screens but no test object. In the processing room unload the film from the cassette and cover half of it with a piece of cardboard or several sheets of paper to prevent light fog. Expose the uncovered portion to safelight illumination for some time (1, 2, and 4 minutes tests). The resultant radiograph may be compared visually or with a densitometer. For visual comparison there should be no detectable density difference on any portion of the radiographic film. If you measure the density of portions, the fogged half of the radiograph should not show more than a 0.02 increase in density over the half which was not fogged.

Any darkroom which can pass the 4-minute test is in excellent condition. If the darkroom passes the 2-minute test, but not the 4 - minute test, it is in good condition and should not be the source of fog. If your darkroom does not pass the 1-or 2-minute tests, then it is time to check the darkroom for unsafe lights. If you do not have new safelight filters, and you are sure there is no unsafe light in the darkroom, it is probably time to install new filters (with 15 - watt bulbs, 4 feet away from the film handling areas). If you still have problems with the fog, check with your film manufacturer's local representative.

#### 4.4. INSTALLATION OF THE PROCESSING ROOM

As the processing room works in closest conjunction with the radiographic rooms, the distance between them must be as short as possible. If there are two or more radiographic rooms the processing room should preferably be situated in a central position.

A processing room must be large enough to accommodate all the necessary equipment without overcrowding. This equipment comprises the loading bench and the processing tanks, each with the requisite accessories. On the loading bench the exposed films are removed from the cassettes and new ones inserted, and it is there that the films are indexed and mounted in their hangers. In the processing tanks the films are developed, rinsed, fixed and washed. It is essential under all circumstances for dry and wet work to be carried out at a safe distance from each other; for this reason the loading bench and the processing tanks are ranged along opposite sides of the room, referred to as the "dry" and "wet" sides. Every processing room must obviously have a sink.

Only if the X-ray department is small should film development and drying of radiographs be carried out in the processing room, and in this case the available space should be correspondingly larger.

The general rule for the lay-out of a processing room is that the film once it has come in from the radiographic room should travel the shortest possible distance and should be put simply and smoothly through the logical sequence of operations without there being any running to-and-fro.

Owing to its proximity to the radiographic room, it is essential for the processing room to be well protected against radiation. The following general rules must be observed:

1. The lead equivalance of the wall adjoining the radiographic room should be sufficient to prevent the films from fogging during the whole time they are in the processing room. Moreover, the storage compartment for the films in their wrappers must then have lead screening. Reserve films should be stored in lead-lined boxes or in a safe place well outside the porcessing room.

2. Where there are discontinuities in the wall (for the cassette transfer cabinet and speakingtube, for instance) any joins in the protective material must fit flush or, better still, overlap.

3. When installing the equipment in the adjoining room, precautions should be taken to prevent the direct X-ray beam from striking the wall of the processing room.

The entrance must be light-tight-where entry is by a single door, it should be kept closed by means of an inside bolt or lock while work is in progress. This is not necessary if a two-door system is used but an interlocking device must be installed to prevent both doors from being opened at the same time.

It is far better to have a "labyrinth", or "maze" as shown in Figure 4.1.

The walls of the hatch must be painted matt-black to prevent any reflections when one of the doors is opened. It is also advisable to have a light signal outside the darkroom entrance to indicate whether the darkroom is in use.

As a darkroom is generally rather humid and there is a real danger of spilling solutions or water, all electrical fittings should be properly earthed and protected against moisture.

A good processing room is well ventilated. The question of adequate ventilation is particularly important in the processing room because it is a relatively small space where all kinds of poisonous and unpleasantly smelling liquids are in use and where, in view of the strict exclusion of white light, there is scarcely any spontaneous ventilation, unless there is a labyrinth entrance.

Large windows, which can be opened after working hours, are to be recommended. The ventilation during working hours should be sufficient to change the air completely 6 to 10 times an hour.

If an electric fan is used it must be light-tight. The air should be blown into the room rather than out, in order to create a slightly positive air pressure and thus prevent dust from being drawn in through the cracks of doors and other openings. The incoming air should pass through filters to remove dust.

Air conditioning is the ideal solution for the processing room, but it is not always possible to install such a system. It is best to maintain temperature of approximately 22°C and a relative humidity of 60 %.

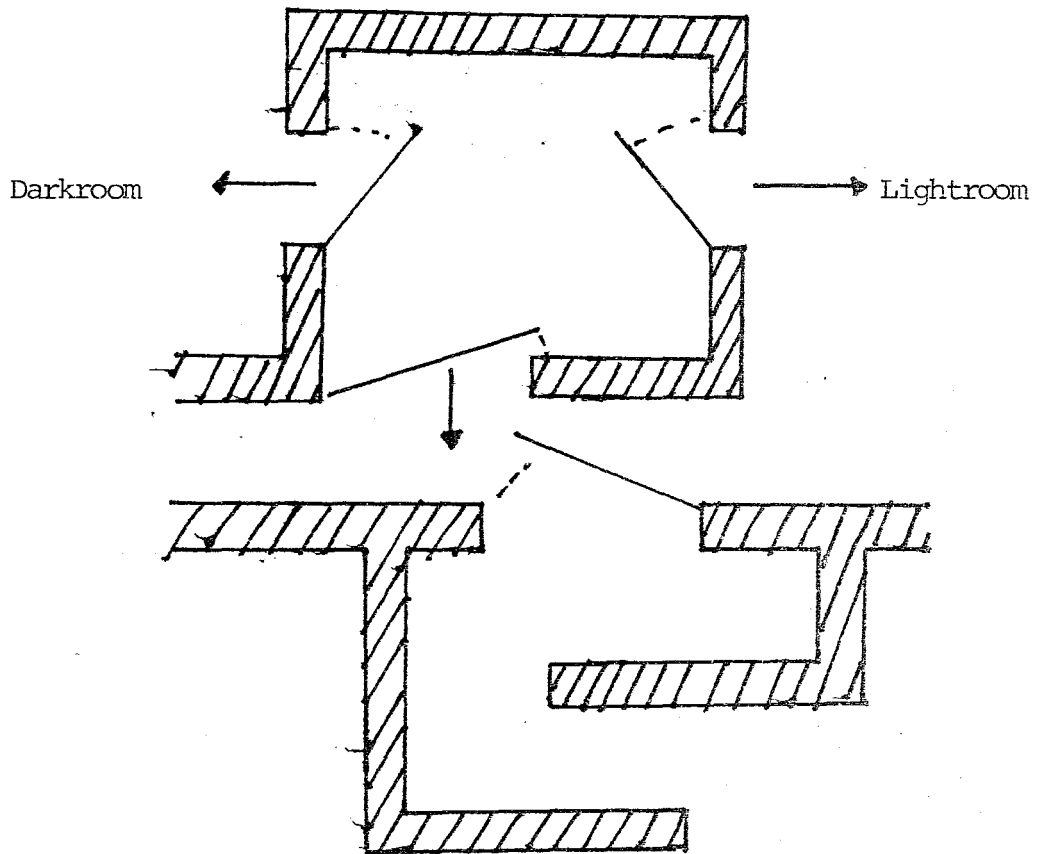

Figure 4.1 : Labyrinth with folding portions.

CHAPTER IV.REFERENCES

1. G.J. Van der Plaats. "Medical X-Ray Technique: Principles And Applications" Cleaver-Hume Press Ltd. 31 Wright's Lane, Kensington-London W-8., 1959.
2. WHO Basic Radiological System "Manual of Darkroom Technique" by P.E.S Palmer University of California Davis, California U.S.A., Geneva 1985.
3. Baines, H., and Bomback, E.S.: "The Science of Photography" 2nd ed. London: Fountain Press, 1967.
4. Mees, C.E.K., and James, T.H.: "The Theory Of The Photographic Process" 3rd ed. New York: The Mac Millian Co., 1969.
5. American Association of Physicists in Medicine: AAPM Report No.4, "Basic Quality Control in Diagnostic Radiology" Chicago, November 1977.
6. Cullian JE, Cullian AM: "Illustrated Guide to X-Ray Techniques" 2nd ed. Philadelphia, JB Lippincott, 1980.

7. Eastman TR: "Radiographic Fundamentals and Technique Guide" St. Louis, CV Mosby, 1979.
8. "Products For Medical Diagnostic Imaging," Pub. No. M5-15 Rochester, Eastman Kodak, 1981.
9. Thompson T.T: Cahoon's Formulating X-Ray Techniques, 9th ed. Durham, Duke University Press, 1979.
10. Gray JE: "Light Fog On Radiographic Films: How to Measure It Properly." Radiology 115:225-227, 1975.
11. Gray JE, Winkler NT, Stears J, Frank ED: "Quality Control In Diagnostic Imaging", Baltimore, University Park Press, 1983.
12. J. Gray, "The Basic Principles of Daily Photographic Quality Assurance". HEW Publications, FDA, 76-8043.
13. WHO, "Quality Assurance In Diagnostic Radiology," Geneva 1982-

## CHAPTER V.

### PHOTOGRAPHIC QUALITY ASSURANCE IN DIAGNOSTIC RADIOLOGY, NUCLEAR MEDICINE AND RADIATION THERAPY

#### 5.1. BASIC EQUIPMENT, MATERIALS, AND MATERIAL HANDLING FOR PHOTOGRAPHIC QUALITY ASSURANCE

##### 5.1.1. SENSITOMETERS

For an effective quality assurance program a sensitometer and a densitometer are needed.

A sensitometer is a device containing a light source (not necessarily a light bulb in the conventional sense) and a timing mechanism designed to give precise, repeatable, and graded light exposures to the photographic film. A sensitometer is essential unless the technologist plans to use preexposed sensitometric control strips. A sensitometric control strip, or sensi strip, is a piece of radiographic film which has been exposed with a sensitometer to produce various densities, or shades of gray, after the film is processed. The processed sensitometric control strips provide the information with which we can monitor the photographic processing conditions(3).

A sensitometric step tablet is used in the sensitometer to give various exposures to the sensitometric control strip. Commercial strips contain from 11 to 21 density steps, or shades of gray and may be from 3 inch to 6 inch long.

#### 5.1.2. PHOTOGRAPHIC CONTROL EMULSION

All radiographic films are made up of one or two layers of photographic emulsion which is the part of the film that is sensitive to light and X-rays. This emulsion is made in "batches". Because of the inherent variability in any manufacturing process, characteristics of these batches may vary by small amounts. For most radiographic purposes these variations are small and not normally perceptible when films are viewed on viewboxes. For quality assurance purposes the changes in speed and contrast from emulsion batch to emulsion batch may be detectable and may be confused with changes in the photographic processors in the radiology department. (3,5)

The photographic control emulsion must be a radiographic film of the same brand and type normally used in the processors in which it will be processed. The photographic control emulsion must be ordered in a sufficient quantity to assure that the same emulsion batch number will be available for 6 months to 1 year. (3)

The photographic control emulsion must be properly stored to assure that the first sheet is the same as the last sheet used. For example, if 500 sheets of radiographic film are to be ordered as the control emulsion, then five 100 sheet boxes should be ordered. Upon receipt of the film, four 100 sheet boxes should be stored under low temperature conditions ( $10^{\circ}$  to  $21^{\circ}\text{C}$ ). When it is necessary to open a new box of film which has been in low temperature storage, it should be stored at room temperature for at least 8 hours. For more details about storage conditions please refer to chapter 8.1.

### 5.1.3. DENSITOMETERS

Next to the sensitometer, the densitometer is the most important piece of quality assurance equipments. A densitometer is a device which measures the blackening, or density, of the radiographic film. A densitometer contains a light source, or possible two, and may measure the density electronically or visually. The visual type of comparison densitometer is the least expensive available and will be adequate for daily quality assurance. (3, 10, 11)

The visual densitometer is a device in which the human eye is used to compare the density of a known value to the density of a sample patch.

#### 5.1.4. THERMOMETERS

The best thermometer to use is a dial type with a 6" or 8" probe. The total range of dial readings should be as small as possible ( $-4^{\circ}\text{C}$  to  $50^{\circ}\text{C}$  as a maximum, and the dial should be calibrated in increments of  $0.5^{\circ}\text{C}$ ).

Bear in mind that, thermometers containing mercury should never be used in photographic laboratories. If such a thermometer is broken in a developing tank, or even in the darkroom, it is virtually impossible to remove all traces of mercury which is a strong contaminant of photographic film even at levels of a few parts per million.

One precaution is that repeatable readings should be taken at different locations in the chemical tank.

One other precaution is necessary when measuring the temperature in radiographic processing chemicals. Never remove the thermometer from the developer, or the fixer tank without immediately wiping the thermometer dry to avoid any amount of chemicals, regardless of how small, from falling into the processor. The thermometer should then be thoroughly rinsed in running water and dried.

#### 5.1.5. RESIDUAL FIXER TEST MATERIALS

The test for residual fixer in radiographs is quite important in a number of respects. This may be the first indication that your radiographs are not obtaining the proper amount of wash. If the proper amount of washing is not obtained, the permanency of the radiographic image will be impaired. After several years fading or staining of radiograph may be noticed. (8, 12)

Residual fixer tests are quite simple to perform, and minimum amount of time and chemicals are required. You may obtain the test solutions directly from a photographic supplier, along with a series of colored patches indicating the amount of stain the test solution should impart to the film.

If you cannot purchase prepared test solutions, the following formula can be mixed and used. (3).

Water	75ml.
28% Acetic Acid	12.5 ml.
Silver Nitrate	0.75mgr.

Add enough water to make 100ml total solution.

The acetic acid and silver nitrate should be "photographic grade". If this is not available, "regent

grade" should be used.

## 5.2. DAILY QUALITY ASSURANCE PROCEDURES:

### ESTABLISHMENT AND MAINTENANCE OF A QUALITY ASSURANCE PROGRAM

#### 5.2.1. PROCESSOR MAINTENANCE LOGS

A processor maintenance log is used to maintain a permanent record of preventive maintenance, corrective maintenance, and cleaning of the radiographic processor. (If films are hand processed, this log will not be necessary, but a similar record should be maintained with information concerning the chemicals, tank cleaning, etc.) Figure 5.1 shows the information which is required on the log. (3)

The "developer temperature" is the temperature at which the processor should be operating. If there is a developer thermometer built into the processor it should be the value indicated on that thermometer. Sudden changes in the developer temperature are not uncommon and may be the result of many factors. The date for the "Developer Temperature Calibrated" refers to the date you measured the actu-

al developer temperature with a calibrated thermometer (not the one built into the processor) and verified that the processor was operating at the temperature you selected. It is also the date that the "Developer Temperature" as indicated on the processor developer thermometer and on the maintenance log was verified as being correct. Similar comments apply to the "Water Temperature " and "Water Temperature Calibrated".

Most processors require that the incoming water temperature be set within certain limits of the developing temperature. This is essential, since exceeding these limits may not allow the processor to adequately control the developer temperature. The "Fixer Temperature" usually can not be monitored from outside the processor but this information should be obtained with an accurate thermometer and recorded. (The temperature of the developer, fixer, and wash water should be within  $\pm 5^{\circ}$  unless the manufacturer provides a different specification).

The date that the racks were last cleaned is important to maintaining good quality films in two respects. If the racks have become encrusted with deposits of chemicals or emulsion which have been sloughed off of the film, artifacts will appear on the processed radiographs. In addition, and most important, when the racks are cleaned, there is always the possibility of contamination of the developer

with fixer, and vice versa. If you detect a drop in the level of the density difference or medium density, the first thing to be suspect should be contamination from cleaning of the racks. If the racks were not cleaned prior to running your sensitometric control strip, then there are other factors which must be considered.

The date for "Developer Filter Changed" may indicate another reason for deterioration of density difference and the medium density. If the filter becomes clogged with foreign matter, the amount of developer agitation in the tank will be decreased. "Developer Replenisher Rates" and "Fixer Replenisher Rates" should be recorded and verified daily. Any time that the rates are changed the information should be changed on the processor maintenance log.

The "Water Flow Rate" and the date "Water Filter Changed" are perhaps the two most overlooked parameters in the radiographic film processing. Some 90-second processors require as much as 9.5lt/minute of water to adequately wash the film. If the rate is less than the figure specified by the manufacturer, your films will be receiving inadequate wash which will result in staining and fading of the radiographs in a relatively short period of time. (3, 11, 12, 14).

A flowmeter should be installed along with a water filter, between the temperature control valve and the photog-

raphic processor. This will allow continuous monitoring of the flow rate and alert you to possible problems. For example, when the water filter starts to become clogged with sand and dirt particles, there will be a drop in the water flow rate. Consequently, the water filter should be changed frequently enough to prevent a decrease in the flow rate below that specified by the manufacturer. In some hospitals or medical centers the flowrate drops to inadequate levels during certain periods of the day. This problem may be corrected by changing the source of water or by changing the size of the pipes feeding the processor and the department.

A good water temperature control valve is essential to quality assurance. This valve will compensate for changes in temperature throughout the day in the hot and cold water and assure that the wash water is maintained at the proper temperature.

The dates for "Developer Replenisher Tanks Filled" and "Fixer Replenisher Tanks Filled" become quite important in detecting improperly mixed batches of replenisher. For example, on the 10th of the month you note a rapid drop in the level of the density difference and medium density. The first item checked should be the dates the racks were cleaned. If they were cleaned on the 5th of the month, this will probably not be the problem since the effect of contamination from the cleaning of racks should be immediately apparent

(within 1 or 2 days). Next, the developer temperature is checked and is found to be within 1 degree of the specified temperature, eliminating this factor. However, on the 9th of the month a new batch of developer replenisher was added to the tanks. This new batch of replenisher should be suspected immediately. If this same batch of replenisher also is being used in other processors you would expect a drop in the level of those processors as well. If there is no such drop you might suspect that the fixer replenisher has contaminated the developer replenisher tanks-or in fact, that the person responsible has put fixer replenisher in the replenisher tank! This can and does happen!

To verify the latter problem, additional developer replenisher may be added to the developer tank. Let the machine run for about 5 minutes. If the resultant sensitometric control strip indicates lower values, the developer replenisher is contaminated or improperly mixed. If the sensi strip increases in density, the replenisher is probably not contaminated and is probably properly mixed.

The "Comments" section of the processor control log is also important. Any preventive maintenance or corrective maintenance performed on the processor should be noted here. Any changes in the replenisher rates, developer temperatures, etc., should be noted here and recorded in appropriate spaces on the form. You should also note "why" the changes were

required.

#### 5.2.2. VARIABILITY IN RADIOGRAPHIC PROCESSING

If you process two sensitometric control strips at the same time, there may be a measurable difference in the densities between two strips. Such variability is referred to as random, or inherent, variability. When the variability in the processing of radiographic film is confined to random variability, the process is said to be "in control".

The random variability may be minimized through the proper selection of sensitometers, densitometers, photographic materials and procedures. The primary concern of a quality assurance program is to assure that the photographic processing is maintained at a stable level, disregarding inherent variability. After reducing the random variability as much as possible, it is then possible to determine the real changes in the process level which are usually due to assignable causes. When these changes are detected it is then possible to take corrective action to direct the process back to the desired level. Corrective action includes any steps indicated by real changes in the process level.

#### 5.2.3. PROCESSING CONTROL CHARTS

A control chart is a graphical method of presenting

data based on a sequence of samples. The control chart consists of a graph showing the average operating level ( $\bar{X}$ ), an upper control limit (UCL), and a lower control limit (LCL). The operating level is the value of the middensity, density difference, or base-plus-fog at which the process should normally operate. The UCL and LCL are the limits that when reached by the process, indicate a change in processing conditions is required in order to maintain an acceptable final product. The UCL and LCL are set so that less than 5 percent of the data points will fall outside of the limits when the process is operating normally. So, if a point falls on or outside of the control limits, you will be correct 95 percent of the time in assuming that a change in the process level has occurred. In "reading" a control chart the current data, as well as the past data, are used to infer the behaviour of the process and assist in predicting shifts in the process level. The control chart is a graph of the process levels showing variability with time. (Figure 5.2).

A control chart indicates the variations of the level of a process with time. The operating level ( $\bar{X}$ ), upper control limit (UCL), and lower control limit (LCL) are indicated.

- a) This control chart shows a process which is in control and is subject only to random, or inherent, variations

b) This control chart shows a process which is out of control. Even though it demonstrates the normal random, or inherent, variations as in (a), it also shows a drift to higher values with time.

Immediate corrective action is required whenever a point falls on either control limit or outside of the control limits.

All of the pertinent information is filled in on the control chart. The process control chart should be maintained by the technologist responsible for quality assurance and he should assure that the information indicated is accurate and up to date. The "Remarks" section of the processing control chart should include notations concerning changes in chemistry, refilling of replenisher tanks, cleaning of processing racks, and any other factors which may effect the process levels.

Keep the following rules for maintaining the processing control charts in mind:

1. Draw in the control limits in red ink. When a data point reaches or exceeds the control limit, action is required.

2. Fill in all information on the control chart regularly.
3. Connect the data points with straight lines... watch for trends.
4. Plot the data which is out of control and circle all three points even if only one point is out of control. Then plot the data points which correspond to the corrected levels while indicating the changes in the "Remarks" section.
5. Indicate changes in chemistry by a double line on the control chart.
6. Keep the control chart up to date, and examine the control chart daily for trends or indications of problems.

#### 5.2.4. EXPOSING AND PROCESSING SENSITOMETRIC CONTROL STRIPS

Random variability may tend to mask real changes in photographic processing. In any case, any and all variability which is not the result of real changes in the photographic processing that affects the final quality of radiographs should be reduced. In this section we will discuss how to reduce, or eliminate variability in directional effects, lo-

cational effects in the processor, time of day variability, the sensitometer and the densitometer. If these effects can not be eliminated, we may find that we are doing more work than required in checking data that appears out of control. (13, 15)

Let us start with the exposing of the sensitometric step tablet and the effects of variability due to the sensitometer. Each sensitometer comes with explicit instructions on its proper use. The instructions may tell you to be sure to set the bulb position at a specified number, to set the amperage meter at a certain level, to wait a specified period of time between exposures, and to replace the lamp after a specified number of hours. The best way to avoid sensitometer variability is to buy a sensitometer from a reputable firm and follow the manufacturer's instructions. Use a voltage stabilizer if one is not built into the sensitometer.

The sensitometric step tablet should be permanently attached to the sensitometer and the sensitometer should be used only for quality assurance purposes. It should be used only by that person, or persons, who know how to care for and feed the sensitometer. If you introduce random variability due to poor technique at this stage, you introduce it into the final data.

The film you use should be selected and handled as

described in section 5.1. Frequent checks should be made to assure that the control emulsion is not being fogged in the darkroom or in the storage refrigerator.

There are two emulsions on most medical radiographic films. One must consider the possibility that the characteristics of the two emulsions are slightly different. If you have a sensitometer that exposes both emulsions simultaneously, this will not present a problem. If you are using a sensitometer that exposes only one side of the film, make two exposures ..... one on each side of the film but in different areas. The resultant densities should be read and averaged, and the average values used for the control chart.

(1,6)

Expose your sensitometric control strip in the same manner each day. If you are using freshly exposed control strips, as is recommended, be sure that the interval between exposure and processing is consistent from day-to-day and for each processor in the department. It is suggested that the sensi strip be processed in not less than 30 minutes no more than 4 hours after exposure.

A major source of variability depends on the manner in which the control strip is processed. Naturally, any changes in agitation, developer temperature, etc., will be apparent. In addition, changes in the control strip may be

caused by the direction in which the strip is fed into the processor (or the orientation in which it is hung in the hand processing tank), the location at which the strip is fed into the processor, i.e., left side, right side, or center (or the location in the hand processing tank), or the time of day at which the strip is processed.

It would appear that the orientation of the strip as it is processed should be irrelevant, but it is not. A difference in density will be noted if the strip is fed in with the dark end leading, with the light end leading, or with the side of the strip leading. This effect is referred to as the directional effect and is most noticeable on step wedges containing 21 narrow steps as in most commercially available step tablets. (Likewise a difference in density will be noted depending on the orientation in which the strip is processed in a hand processing system). A change in density on the order of 0.10 or greater may be anticipated at a density level of 1.0 between two strips of which one was processed with the light end leading compared to one with the dark end leading. Likewise, a density change of 0.25 or greater may be noted at a density of 0.50. The three patch sensitometric control tablet should eliminate the possibility of directional effects in most processors. To avoid variability because of this factor, it is advisable to process any sensi strip with light end leading, i.e., the end which will produce the lightest densities on the final processed strip (1). It is

also recommended that the strip be processed with the light end upward and with the strip in the center of the hand processing tank.

One more attention is that the sensi strips should be processed at approximately the same time every day.

#### 5.2.5. ESTABLISHING OPERATING LEVELS AND CONTROL LIMITS

The judicious selection of operating levels, those values of the B+F, MD, and DD which will be used as a normal LEVEL, and the upper and lower control limits, is essential to maintain a high level of radiographic processing quality. All processors in the department using the same chemistry and processing the same type of film (for the same procedures) must process to the same levels with the same control limits. This is especially convenient if one processor is taken out of operation unexpectedly in the middle of a study. No change in technique will be required regardless of the processor used. (4).

If the one processor is operated at an optimum level, then all processors in the department can be operated at this level. If the radiologist prefers lower contrast films, then the technique may be modified to provide such films, i.e., using a higher  $kV_p$ . This in turn assists in reducing patient dose. But as a general rule of thumb the following

applies:

All processors in a clinical department used for large format films should be maintained at the same operating level.

In order to provide proper operating level, it is necessary to operate your processor at the optimum levels specified by the film manufacturer. This procedure will provide you with the proper processing conditions for the film-developer combination of interest. Once you have optimized one processor, or determined the manufacturer's recommendation for optimum processing conditions, drain the developer tanks of the other processors in the department, flush the tanks and developer racks with water, and replace the developer recirculation filters (if present).

Do not use any type of cleaner in the developer tank or on the developer racks at this time. Fill the developer tanks with fresh developer.

Set the film transport speed (if variable), the developer and the water temperature as recommended by the manufacturers. Allow the processor to operate for 1 hour, and continue operation until approximately 75 sheets of 35x35cm. (or 30x40cm.), per gallon (3.79lt) of developer have been processed in order for the chemistry to equilibrate. Expose

and immediately process at least three sensi strips in each processor. Determine the average values for the B+F, MD, and DD for all the strips and processors. The average values of B+F, MD, and DD will become the operating level values for all processors; that is, the processing control charts for each processor will use the average values determined above as the operating level.

After the proper control limits have been established, it may be necessary to adjust the temperature slightly, or some other parameter, to assure that all processors are operating within the control limits at this operating level.

If your department is using a good quality sensito-meter and densitometer with automatic processing, the upper and lower control limits on MD and DD should be  $\pm 0.10$  and  $-0.10$  respectively and  $\pm 0.05$  for B+F. If you are using hand processing, you may accept slightly wider control limits of  $\pm 0.15$ . But with a little care  $\pm 0.10$  limits can be maintained even with hand processing.

#### 5.2.6. CORRECTIVE ACTION

Whenever a data point falls on, or outside of, the upper or lower control limits, corrective action is required. (4). Since you will not have the sophisticated tools available for chemical analysis to determine exactly what constitu-

tent is lacking or reduced in concentration, there are a limited number of corrections that you can make. The basic variables you can manipulate include the developing temperature, the rate of replenishment, the addition of replenisher to the developing tank, the processing of fully exposed film without replenishment, or change of chemistry.

In many cases a slight adjustment in the developer temperature may bring the processor back into control. However, if you are processing more than one type of film in your processor, the resultant change in temperature may not affect the two films in the same manner. Consequently,

Recommended adjustments in temperature and/or development time based on the sensi strips apply only to that particular film-developer combination and should not be carried out if more than one type of film is processed in that particular processor.

If more than one type of film is processed and you can not adjust the levels by adding replenisher or processing exposed film without replenishment, the only alternative is to change the chemistry. (10)

If there occurs over replenishment of developer, process a number of fully exposed 35x35cm films without

replenishment, in addition to adjusting the replenishment rate.

Temperature changes: If you look at the curves given in Chapter 3 closely, you should be able to predict what changes in temperature will result and what modifications in temperature you can make to correct for shifts in the control parameters.

Developer replenisher rate changes: If you notice a steady increase in all of the parameters over a period of few days, it may indicate that the replenishment rates are too high. If, however, you find that the increase started immediately after refilling the replenisher tanks, you should suspect that the replenisher has been improperly mixed. (i.e., too strong). In either case you must take corrective action. In the first case where the levels have been rising over a period of time (not preceded by the refilling of the replenishment tanks) you will want to decrease the replenishment rate immediately (probably by about 20 percent) and modify the developer to bring the sensi strips back into control.

(4)

In the second case where you suspect that the replenisher may be too strong, you may want to add a small amount of water to the present developer replenisher solution. A starting point would be the addition of about 10 percent wa-

ter to the solution in the developer replenisher tank. In order to reduce the replenishment rate, you may also process several sheets of completely exposed films without replenishment to bring the processor back into control.

If you notice a steady decrease in the MD and DD, your system is probably under-replenished or the replenisher is improperly mixed (too weak). In either case you want to increase the activity of the developer in the processor and this can best be carried out by the addition of replenisher to the developing tank. If you can correct the operating levels in this manner, it is apparent that you have under-replenished. In this case increase the developer replenishment rates by 20 percent and proceed to use the processor normally. If, however, after you add a liter or two of replenisher you notice that the levels are still decreasing, the developer replenisher may be too weak or contaminated. This batch of replenisher should be discarded and a new batch mixed under close scrutiny. At this point it is probably better to discard the developer in the processing tank as well and mix both fresh developer and replenisher. The replenisher tank should be thoroughly flushed with water to remove all traces of the previous replenisher.

In any situation where you modify the replenishment rates, it is necessary to maintain a close watch on the day-to-day data to assure that the B+F, MD, and DD are not

drifting. (12, 14)

Developer modifications: It is possible to change the activity of the developing solutions chemically and avoid the necessity of discarding the developer and mixing new solutions. This is particularly advantageous where large quantities of developer are used in the developing tank or where work loads dictate a minimum of interference with clinical radiographic processing. In addition, each time new developer is added to the processor it is necessary to adjust the levels appropriately.

The first modification is due to overreplenishment. In this case you should process approximately 2 sheets of 35x35cm. X-ray film per liter of solution in the developer tank. This film must be completely exposed (to room lights) and processed without replenishment. The procedure described below should be observed.

1. Process an additional sensi strip to verify that the processor is out of control.
2. Process 2 sheets of completely exposed 35x35cm. X-ray film (or the equivalent) per liter of developer without replenishment.
3. Allow the machine to operate without processing

any film for at least 5 minutes.

5. Process and read two more sensi strips. If the values are now within the control limits, plot the points on the control chart and indicate the modification required under "Remarks". If the values are still outside of the control limits repeat steps 1 through 4.

Another modification that is available for the developer solution is the addition of replenisher directly to the developer tank in the processor, or to the tank in a hand processing set-up. Replenisher should be added in units of 100ml per liter of developer solution. Now, follow the steps 1 through 4 outlined above except that step 2 now consists of adding replenisher only to the developing tank.

Remember, in taking corrective actions, if all else fails, change the chemistry.

### 5.3. DAILY QUALITY ASSURANCE CHECKS

The following steps should be carried out on a daily basis: (3, 17)

1. Manufacturer's machine start-up procedures should be followed.

2. Cleanup sheets should be run when the processor temperatures (developer, fixer, wash, dryer) reach the operating level.
3. Replenisher rates should be checked while running the cleanup sheets to assure that the replenisher system activator switches are functioning properly and to assure that the processor is receiving the appropriate amount of replenisher.
4. Water, developer, and dryer temperatures should be checked.
5. Water flow rates should be checked
6. After the processor has been operating for at least 1 hour, the sensitometric control strip should be processed and read, and the resultant data plotted on the control charts.
7. Any required corrective action should be taken and the processor certified as in control before clinical radiographs are processed.
8. At the end of the day the shutdown procedures described by the manufacturer of your processor should be followed.

9. Darkroom and processor cleanliness should be checked.

In making these daily checks you should also make sure that the processor is running in a normal condition. Unusual noises should be reported to maintenance personnel as soon as they are detected. There should be no traces of chemicals, dry or wet, anywhere in the darkroom or on the inside of the processor.

The no smoking sign should be observed without exception in the darkroom. Regardless of how careful the smoker tries to be, cigarette ashes will be found as artifacts on radiographic films. Normally ashes tend to cling to intensifying screen surfaces making frequent cleaning a requirement. Ashes will also be carried into the processor and can contaminate the processing solutions. In addition, the light from a cigarette can readily fog radiographic films. (14)

One of the first checks that should be made as part of the start-up procedure is to assure that the developer and fixer solutions are at the overflow level. A check should be made to assure that the racks and crossovers are properly installed. The covers and doors of the processor should be checked to be sure that they are properly closed and light tight.

At least three 35x35cm (or 30x40 cm) clean-up sheets should be run through the processor when the developer and dryer have reached their operating temperatures. These sheets should be checked for scratches or other processor defects. Outdated films can be used for this purpose. However, clean-up sheets should be used only once.

Water flow rates should be checked to assure that an adequate supply of wash water is available to the processor. In some areas it may be necessary to change the water filters every 2 or 3 days due to water conditions. A reduced flow rate is the first indication that the water filter needs to be changed.

The processor should be allowed to operate for approximately 1 hour after the machine reaches operating temperature. The sensitometric control strip should then be processed and read, and the data plotted. If the strip indicates that the processor is out of control, a second strip should then be processed and read, and the data plotted. If the strip indicates that the processor is out of control, a second strip should be run. If this second strip indicates that the processor is out of control, corrective action is necessary.

As part of the shutdown procedure it is a good idea to leave the cover of the processor open slightly. This al-

lows the chemical fumes to escape and prevents the condensation of moisture on the inside of the processor. All chemical deposits should be removed from the processing section as part of the shutdown procedure. (4, 8)

#### 5.4. WEEKLY QUALITY ASSURANCE CHECKS

The procedures described below should be carried out on a weekly basis.

1. Clean the processing racks using running water and a clean cloth. Remove chemical deposits with a soft brush.

COUTION: Use the appropriate splash guards when removing the developer and fixer racks. Relatively small amounts of fixer can contaminate the developing solution.

2. Clean all exposed surfaces (internal and external) with a damp cloth to remove all deposits, (regardless of how small), chemicals and other dirt.

Do not use systems cleaner on the racks or any other acid cleaner, strong detergent, or abrasive cleaner.

After completion of the weekly cleaning, process a sensitometric strip and verify that the processor is in control.

3. Check films for residual fixer
4. Verify that the silver reclaiming apparatus (if any in your department) is operating and that an optimum amount of silver is being reclaimed from the fixer.
5. Check water flow rates and replace the water filter.
6. Check intensifying screens for cleanliness, abrasions or faulty light seals.

The developer and fixer racks should be handled separately at all times and should not be cleaned in the same sink until the sink has thoroughly been flushed with fresh water.

In addition, check the manufacturer's instructions regarding procedures required for weekly preventive maintenance.

### 5.5. RESIDUAL FIXER TESTS

Another important weekly procedure is the checking of processed film for residual fixer. Small amounts of fixer remaining in the radiographic films after processing will combine with the silver of the image to form silver sulfide. This procedure stains and causes fading of the radiographs after relatively short periods of time, i.e., for 5 to 10 years, it will be necessary to assure that a minimum amount of fixer remains in the processed radiograph. (17)

The test procedure is as follows: Process one sheet of unexposed radiographic film in the normal manner. Place one drop of residual fixer test solution on each side of the film but on different areas so that the spots on the two sides are not superposed. Allow the test drops to stand for 2 minutes, blot off the excess and compare the stain with the test color patches which may be obtained from most photographic dealers. (5)

### 5.6. MONTHLY QUALITY ASSURANCE CHECKS

1. Replace the development and fixer recirculation filters
2. Clean intensifying screens with the appropriate cleaners.

If any of the processors handles a large volume of film, the filters should be changed after approximately 5,000 films have been processed. Consequently, this may have to be done on a biweekly or weekly basis.

Surgical sponges are excellent for cleaning the intensifying screens. Use two or three sponges for applying the cleaner and six to eight clean, dry sponges to completely dry the screen. Be sure to leave the cassettes open so that the screens may dry completely.

Outside of the cassettes should be cleaned with either the recommended cleaner or a damp cloth and mild soap. Be sure to remove all traces of contrast medium on the cassettes.

Anti-static solution can be used to reduce static marks especially under low humidity conditions. This cleaning and anti-static solution can also be used on all film handling surfaces and feed trays of the processors.

#### 5.7. OTHER PERIODIC QUALITY ASSURANCE PROCEDURES

At least every 6 months the screen-film contact should be checked on all screens. This is a simple procedure requiring a 15" x 18" piece of 1/8" wire mesh screen. Load the cassette with the normal film and radiograph the screen mesh so that it covers the entire cassette. Use an exposure

of approximately one-half the normal exposure for a radiograph of a hand with the same screen-film combination. When the processed film is viewed at a distance of 1 to 1.5 meter, any areas not making good screen-film contact should be removed immediately from use.

Follow all of the manufacturer's suggestions concerning periodic preventive maintenance including lubrication, safety checks, and mechanical adjustments.

#### 5.8. SEASONING THE PROCESSOR TANKS AND RACKS

If systems cleaner is used in a photographic processor (should be used as seldom as possible), it is essential to season the processing tanks before placing fresh chemicals in the tanks and attempting to re-establish the previous operating levels.

Fill the processor tanks with fresh developer and fixer, each diluted with equal parts of water. (Always add the fixer first and then flush the developer tank with water before adding the developer to avoid contamination of the developer with fixer). Do not add the starter solution, and do not the recirculation filters. Turn the processor on and allow it to operate without processing film for at least 30 minutes. This process is known as seasoning of the racks and tanks. Since the developer systems cleaner is a strong

acid, and the developer itself a strong alkali, any traces of the cleaner remaining on the racks or in the tanks will tend to neutralize the developer solution. By operating the machine with solutions in the tanks for at least 30 minutes, most of the residual cleaning solution will be neutralized by the solutions in the tank. These contaminated, diluted processing solutions can then be discarded and replaced with fresh developer and fixer. Without following the seasoning procedure, the developer solution activity level would drop off considerably over the first few hours making the establishment of proper operating levels on the fresh chemistry nearly impossible.

During the 1 hour that the processor is seasoning, you can drain the water from the replenishment tanks and fill the tanks with fresh replenisher. When the replenishment tanks are filled, it will be necessary to pump all possible traces of water out of the replenisher system. This can be accomplished by depressing the replenishment pump activation switch or the microswitch on the sensing roller. The replenishment pumps should operate in this manner for at least 5 minutes.

After the processor has been seasoned, drain the chemicals and flush the tanks and racks with fresh water. Be sure all of the solutions have been drained from the processor (check places like the recirculation filter holders, etc.). replace the developer and fixer recirculation filters and as-

sure that the tops of the filter holders are securely fastened. Fill the processor with fresh chemical; filling the fixer first, then flushing the developer tank before filling with fresh developer.

PROCESSOR MAINTENANCE LOG

Processor \_\_\_\_\_

Developer Temperature \_\_\_\_\_

Dev. Temp. Calibrated \_\_\_\_\_

Fixer Temperature \_\_\_\_\_

Water Temperature \_\_\_\_\_

Water Temp. Calibrated \_\_\_\_\_

Water Flow Rate \_\_\_\_\_

Developer Replenisher Rate \_\_\_\_\_

Fixer Replenisher Rate \_\_\_\_\_

Developer Replenisher Tanks Filled

\_\_\_\_\_  
\_\_\_\_\_  
\_\_\_\_\_  
\_\_\_\_\_

Water Filter Changed

\_\_\_\_\_  
\_\_\_\_\_  
\_\_\_\_\_  
\_\_\_\_\_  
\_\_\_\_\_

Chemicals Changed \_\_\_\_\_

Developer Filter Changed \_\_\_\_\_

\_\_\_\_\_

\_\_\_\_\_

\_\_\_\_\_

\_\_\_\_\_

Fixer Replenisher Tanks Filled

\_\_\_\_\_  
\_\_\_\_\_  
\_\_\_\_\_  
\_\_\_\_\_

Racks Cleaned

\_\_\_\_\_  
\_\_\_\_\_  
\_\_\_\_\_  
\_\_\_\_\_  
\_\_\_\_\_

Comments \_\_\_\_\_

\_\_\_\_\_  
\_\_\_\_\_  
\_\_\_\_\_  
\_\_\_\_\_  
\_\_\_\_\_

Figure 5.1. Processor maintenance log.

- a. This control chart shows a process which is in control and is subject only to random, or inherent, variations.

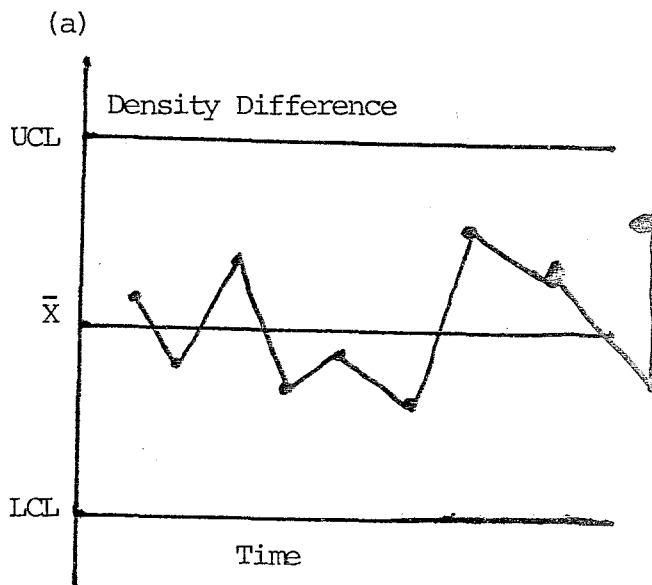

- b. This control chart shows a process which is out of control. Even though it demonstrates the normal random, or inherent, variations as in (a), it also shows a drift to higher values with time.

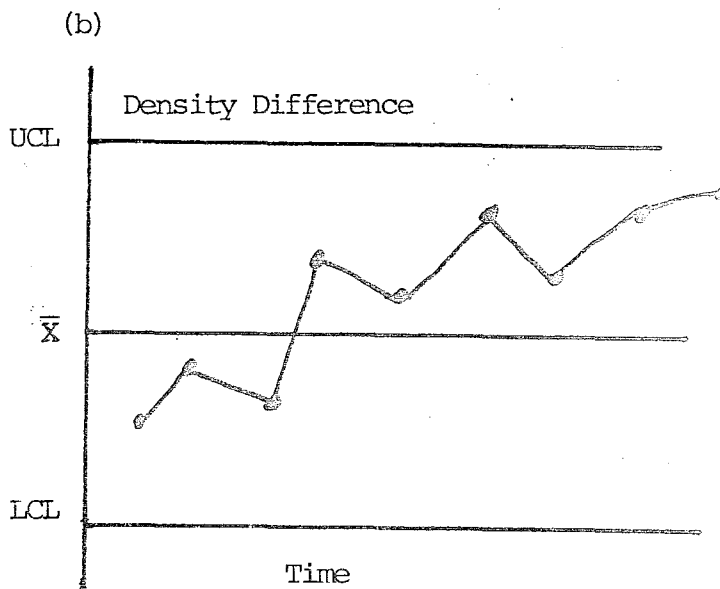

Figure 5.2 : Basic control charts.

A control chart indicates the variations of the level of a process with time. The operating level ( $\bar{X}$ ), upper control limit (UCL) and lower control limit (LCL) are indicated.



CHAPTER V.REFERENCES

1. Barrows, R.S., "Factors Affecting The Recognition of Small, Low Contrast Photographic Images", Photogr. Sci. Eng. 1: 15-22, 1957.
2. Bourne, D., "Repeats-An Aspect of Departmental Management", Radiography 35: 257-261, 1969.
3. J.E. Gray. Univ of Toronto, Ontario, Canada. "The Basic Principles of Daily Photographic Quality Assurance", Quality Assurance Series Diagnostic Radiology, Photographic Quality Assurance in Diagnostic Radiology, Nuclear Medicine, and Radiation Therapy Vol. I HEW Publication (FDA) 76-8043, June 1976.
4. Chamberlain, W.E. and R.R. Newell, "Development of Roentgen Films: A Method of Determining the Potency of Developer", Am. J. Roentgenol. 23: 549-552, 1930.
5. Corney, G.M. and H.E. Seeman, "A Logarithmic Step Tablet for X-Rays", Nondestructive Testing 6:27, 1947.

6. Faix, C.D., R. Van Tuinen and J.C. Kereiakes, "Quality Control for Automated X-Ray Film Processing", Radiol. Technol. 44: 257-261, 1973.
7. Trout, E.D. et. al. "Analysis Of The Rejection Rate Of Chest Radiographs Obtained During The Coal Mine Black Lung Program" Radiology, 109: 25 (1973)
8. HALL, C.L. "Economic Analysis Of A Quality Control Program. Application Of Optical Instrumentation In Medicine, VI". Proceedings of the Society Of Photooptical Instrumentation Engineers, 127: 271: (1977)
9. Brown, M.R. "Preventive Maintenance Reduces X-Ray Equipment Costs". Dimensions In The Health Service, 51:3 (1974)
10. G.J. Vander Plaats Proff. of Radiology, Univ. of Groningen "Medical X-Ray Technique" N.V. Philips" Gloeilampenfabrieken, Eindhoven, Holland, 1959.
11. Hanson Blaatz Director, Office of Radiation Control The City of New York. Ass. Prof. of Industrial Medicine N.Y. Univ. Medical Center. "Introduction to Radiological Health" Mc. Graw-Hill Book Company, N.Y.
12. Whittaker, L.R. "Quality Control In X-Ray Departments at Kenyan District Hospitals" Unpublished report to WHO, 1980.

(Available from: Radiation Medicine, WHO, 1211 Geneva 27, Switzerland)

13. Burkhard, R.L. "Quality Assurance Programs For Diagnostic Radiology Facilities" Washington, D.C. United States, FDA, 1980 (HEW Publication. FDA 80-8110)
14. Bates, L.M. "Some Physical Factors Affecting Radiographic Image Quality: Their Theoretical Basis And Measurement" Public Health Service, Publication Number: 999-RH-38 (1969)
15. Sensitometric Properties of X-Ray Films, Eastman Kodak Co., Rochester, New York 14650 (MA-2) 7-72-AX.
16. R. Burkhart, "A Basic Quality Assurance Program for Small Diagnostic Radiology Facilities", HEW Publications, FDA 83-8218.
17. U.S. Department of Health and Human Services, "Nationwide Evaluation of X-Ray Trends (NEXT)", FDA, April 1984.
18. Eastman TR: "Radiographic Fundamentals and Technique Guide" St. Louis, CV Mosby, 1979.
19. Gray JE, Winkler NT, Stears J. Frank E.D: "Quality Control In Diagnostic Imaging" Baltimore, University Park Press, 1983.

## CHAPTER VI.

### IMPLEMENTATION OF QUALITY CONTROL FOR A MANUAL PROCESSOR

#### 6.1. MANUAL TREATMENT OF MEDICAL X-RAY FILMS

The medical X-ray film exposed with or without intensifying screens, must be processed. This can be done manually or automatically. The manual processing includes:

- i. Development
- ii. Rinsing
- iii. Fixing
- iv. Washing
- v. Drying

##### 1. The development:

The different parameters influencing the photographic result during the development are:

- chemical composition of the developer,
- film agitation during the development,
- temperature of the developer,
- developing time,
- replenishment of the developer,

a) The agitation:

Immerse the film in the developer and then raise and lower the hanger several times at a uniform rate (during 30 seconds). This will remove the bells of air from the surfaces of the film and wet thoroughly by means of the developer. This agitation should be repeated once every minute (during 5 seconds). This prevents white spots on the film. At the same time, a constant developer temperature is insured and the added replenisher will be perfectly mixed.

After certain time, when the timer sounds, remove the film quickly without allowing the solution to drain back into the developer tank. Doing in this way, it will prolonge the life of the bath.

b) The developing time:

Exact time-temperature processing is preferable to processing "on view", which actually takes more of the technologist's attention and demands greater skill and judgment. Variations in eye accomodation, the low level of illumination in the darkroom and the opacity of the uncleared film make processing on view very difficult and subject to error.

The standardised manual development consists of a constant developing time by using a timer. The developing

time in a phenidone - hydroquinone developer at 20°C is for

TABLE 6.1 (1)

Screen films	4 minutes
No-Screen films	5 minutes
Photofluorographic films	
Films for image-intensifying photography (cine-spot)	6 minutes

C) The developing temperature:

The temperature of the developer is normally controlled by a thermostat; the fluctuations on the temperature should be maximum 1°C. The temperature can vary a little, but the development time must be adapted:

TABLE 6.2

<u>Temperature</u>	<u>Development Time</u>
18°C	6 min.
20°C	4 min.
22°C	3 min.
24°C	2 min.
26°C	1.5 min.
28°C	1 min.

A temperature of 20°C is recommended. Although developing temperatures higher than 20°C may be used to obtain shorter processing times. Temperatures above 28°C should be avoided because the developing time becomes too short for adequate time-control. A temperature under 18°C takes too long developing time and is certainly not economical. Always contact your film manufacturer for appropriate chemicals and recommended temperature-time tables.

d) Replenishment of the developers:

A developer is a chemical that converts the latent image into a visible metallic silver image. This means that the film is a consumer of developer, and through this, the concentration of developing agents will decrease. So, the activity of an unreplenished developer gradually diminishes by exhaustion. This exhaustion, unless compensated, will gradually result in underdevelopment and affect contrast adversely. The best way to compensate these losses is to use a replenisher system, which is efficient and simple and requires to add a stronger solution to the original developer which permits to maintain a constant developing time. The replenishment performs a double function: First, maintaining the liquid level in the tank and second, the activity of the solution.

---

Used developer + replenisher =  $\frac{1}{2}$  fresh, new developer

---

With this method, the film should be removed from the developer quickly without allowing the excess of solution to drain back into the tank. The replenisher quantity is in function of the developed amount of films.

For each 1 m2 film, we need 0.4 lt. of replenisher.

1 m2 film = 43 films (13x18cm) = 23 films (18x24cm)  
 = 14 films (24x30cm) = 8 films (35x35cm)  
 = 9 films (30x40cm)

After a little experience the knack of withdrawing the correct amount of solution on the film will become almost automatic. As the composition of the developers could be different, we must replenish with the adapted replenisher. If we use G150 (Agfa-Gevaert) solution as developer, as we did in implementing the quality assurance program reported in this thesis, we will also use the G150 (Agfa-Gevaert) solution as replenisher. For the G150 developer;

---

-1 part concentrated + 5 parts of water = DEVELOPER

-1 part concentrated + 3 parts of water = REPLENISHER

---

Replenishment must be done daily and after 2 times the tank capacity we have to renew the developer. In any case, the solution should be discarded at the end of three months because the aerial oxidation and accumulation of gelatin, sludge and mechanical impurities which find their way

into the solution.

## 2. Rinsing:

After a film has been developed, it should be immersed in a rinse bath. The best is clean, circulating water (about 4lt/min) during 20 seconds at 20°C. Doing so, the film will be completely cleaned of developer, preventing the fixing both against early exhaustion. If we bring the developed film directly into the fixer, streaks, stripes or irregularities appear on it.

## 3. Fixing:

Fixing time equals two times the clearing time. The clearing time depends on the used film type, composition of the fixer, the temperature and the agitation.

A fixer works faster at high temperature and when it is well agitated. The time required for the complete disappearance of the original milky aspect of the film is known as the clearing time. It is during this procedure that the fixer is dissolving the undeveloped silver halides.

However, an equal amount of time is required for the dissolved silver salts to diffuse out of the emulsion layer and for the gelatin to be hardened adequately. Thus, the

total fixing time is greater than the clearing time.

A fixer solution is usually replenished by the addition of diluted fixer. When the clearing time is double the time in relation to a fresh fixer, it is necessary to renew the fixer.

#### 4. Washing:

The film must be properly washed in order to remove the rests of the fixer from the emulsion layers. A good supply of running water is necessary. The time required for adequate washing depends on water temperature, the rate of flow, the type of film (non-screen films require a longer washing than screen films).

Because the average filing time is 15 years, it is necessary to wash the films for about 20 minutes at 18-20°C.

#### 5. Drying:

Before drying, it is advisable to immerse the film into a wetting agent for shortening drying time and for preventing drying marks or spots. (1) Use 0.5 to 1 ml of AGEPON per liter in water for 30 seconds in case of Agfa-Gevaert X-ray films and chemicals. (Agepon is the wetting agent of Agfa-Gevaert).

A properly dried film has a smooth, even surface and does not feel tracky. The used temperature is 35 to 50°C.

The drying time can be decreased by using:

- 1) a hardening fixer
- 2) a wetting agent after final washing
- 3) a sufficient air circulation in the drying cabinet
- 4) a sufficient wet air evacuation
- 5) Squeezing the films before putting them into the drying cabinet.

Typical values for manual processing are given in Table 6.3.

TABLE 6.3 Typical Manual Process

Stage	Time	Temperature
Developing	4 min	20°C
Rinsing	10 sec.	15°C
Fixing	10 min.	20°C
Washing	15 min.	15°C
Drying	30 min.	40°C
Total	60 min.	

## 6.2. IMPLEMENTATION OF A QUALITY CONTROL PROGRAMME FOR A MANUAL PROCESSOR IN ISTANBUL

Since Agfa-Gevaert Curix RP-1 Medical X-Ray Films are used in Turkey, Agfa-Gevaert chemicals were used in this quality assurance procedures. The tools we used in this procedure were;

- Agfa-Gevaert Curix RP-1 Test Film as Control Emulsion
- Densitometer (Analog-Agfa-Gevaert)
- Strips for measuring pH values of developer and fixer, silver content of fixer, density of developer and fixer
- Thermometer
- Residual fixer test material

This programme was conducted in a private clinic, patient capacity of 8-10 daily. Observations and replenishment rates are given on the quality control charts next to chapter 6.

Before we have stated the quality assurance program we noted slow speed (1.98) and poor contrast level (1.50) in the center. They were using improper chemicals and the chemicals were old (1 month). There were no daily replenish-

ment of chemicals and the tanks were dirty.

We first began the quality assurance programme by cleaning the tanks throughly and changing the chemicals. Agfa-Gevaert chemicals Curix RP-1 films were used in the center.

In the beginning, the technologist did not obey film processing rules. He processed the films as he knew. That is, he did not use time-temperature table, he checked the contrast and density of the film by sight.

He took the film from the developer tank, checked the contrast under the red light filter. But he saw that, the films began to develop earlier than he was accustomed to. First, he thought that the developer was very strong. At that moment we advised him to decrease the mAs level and therefore the X-ray dose given to the patient.

He decreased the X-ray dose given to the patients and began to obey processing rules (time-temperature table, etc.). We always dropped off the chemicals remaining on the developed film to another cup, so that developer and fixer never mixed to each other. Replenishments were done daily (for 1 m<sup>2</sup> of film 0.4 lt of developer and fixer). We conducted the programme for a month. The conclusions are as follows:

1. The speed and the contrast levels were improved by using proper chemicals (Agfa-Gevaert G-150 chemicals for Agfa-Gevaert RPl films).
2. Base plus fog level remained constant.
3. During one month speed and contrast levels remained within tight limits.  
So that no visual change had been noticed between the films.
4. mAs values, therefore patient dose, were decreased to reasonable limits.(25-35% reduction).
5. During this study repeat rate decreased from 12% to 6%.
6. As a result of (4) and (5) X-ray dose given to the patient and to the technologist has decreased.
7. The cost effectiveness of the center increased, for reasons explained in recent chapters (i.e. tube life).

If we examine the quality check chart base plus fog level is 0.17, speed is 1.67 and contrast (G) is 2.65. The figures remained in the tight limits throughout quality

assurance procedures. In the fifth day speed and contrast decreased. Especially the contrast level came to the lower limit. This is because the technologist did not obey the quality control rules in the beginning. He poured the waste chemicals from the developed films back to the tanks. He did not wash the films properly. Therefore, we could not follow the replenishment procedures properly. We explained the reason why the contrast came to the lower limit in 5 days to the technologist. Then, we implemented a corrective action. We removed 1.5 liters of developer and fixer from the tanks, and added 2.5 liters of replenisher to the tanks.

After good agitation, we processed one control emulsion according to the processing rules and we obtained good result. After this experience, the technologist began to obey quality assurance rules and the figures always remained within tight limits. Sensitometric curve obtained before and after the QA programme as well as the one month control chart are given at the end of this chapter.

**SENSITOMETRIEBLAD**  
**FEUILLE SENSITOMETRIQUE**  
**SENSITOMETRIEBLATT**  
**SENSITOMETRY SHEET**

Nr. - No.

Datum - Date  
 Nr. Testwig - No. Coin d'essai  
 Nr. Testkeil - No. Test wedge

1/5/1991

Systeem - Système - System

Machinetype - Type de machine  
 Maschinentyp - Type of machine

Manual

Processing-tijd - Durée de traitement - Verarbeitungszeit -  
 Processing time

2 weeks

Not defined

Ontwikkelaar - Révélateur  
 Entwickler - Developer

Arbitary

Fixeerbad - Fixateur  
 Fixierbad - Fixer

Aantal films per dag - Nombre de films par jour - Filmzahl pro Tag -  
 Number of films per day

Temper.: Ontwikkelaar - Révélat.  
 Entwickler - Developer  
 Fixeerbad - Fixateur  
 Fixierbad - Fixer  
 Water - Eau - Wasser

21.5 °C

18.5 °C

19 °C

Regen. - Replen.

Ontwikkel. - Rével. Entwick. - Devel.	Fix.

ml/m<sup>2</sup>, of-ou-oder-or  
 ml/14 in. of-ou-oder-or  
 ml/min.

Ag 13 g/lit.

Archiveerbaarheid  
 Conservabilité en archive  
 Archiverbarkeit  
 Archival permanence

Printed in Belgium

MR/979/1992

GEVAERT

AGFA-GEVAERT

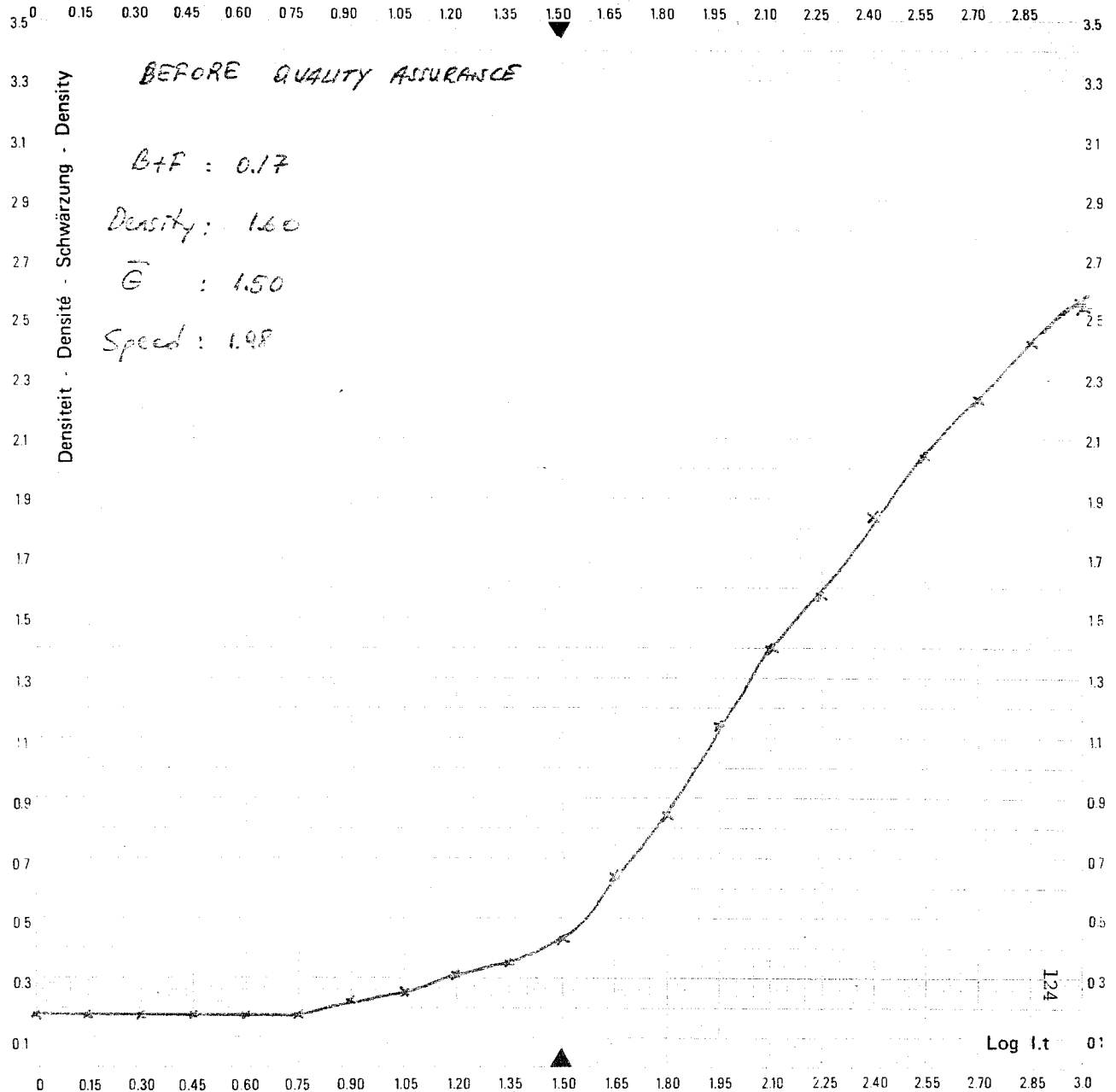

SENSITOMETRIEBLAD  
FEUILLE SENSITOMETRIQUE  
SENSITOMETRIEBLATT  
SENSITOMETRY SHEET

Nr. - No.

Datum - Date 11/5/1986  
 Nr. Testwig - No. Coin d'essai  
 Nr. Testkeil - No. Test wedge

System - Système - System

Machinetype - Type de machine  
 Maschinentyp - Type of machine Manual

Processing-tijd - Durée de traitement - Verarbeitungszeit  
 Processing time Developer 4 min.

Ontwikkelaar - Révélateur AGFA-GEVAERT  
 Entwickler - Developer G-150

Fixeerbad - Fixateur G-150  
 Fixierbad - Fixer

Aantal films per dag - Nombre de films par jour - Filmzahl pro Tag - Number of films per day 21

Temper.: Ontwikkelaar - Révélat.  
 Entwickler - Developer 21 °C  
 Fixeerbad - Fixateur  
 Fixierbad - Fixer 20 °C  
 Water - Eau - Wasser 17 °C

Regen. - Replen.

Ontwikk. - Rével. Entwick. - Devel.	Fix.

ml/m<sup>2</sup>, of-ou-oder-or  
 ml/14 in. of-ou-oder-or  
 ml/min.

Ag 0 g/lit.

Archiveerbaarheid  
 Conservabilité en archive  
 Archivierbarkeit  
 Archival permanence ~ 20 years

Printed in Belgium

MR/979/1992



AGFA-GEVAERT

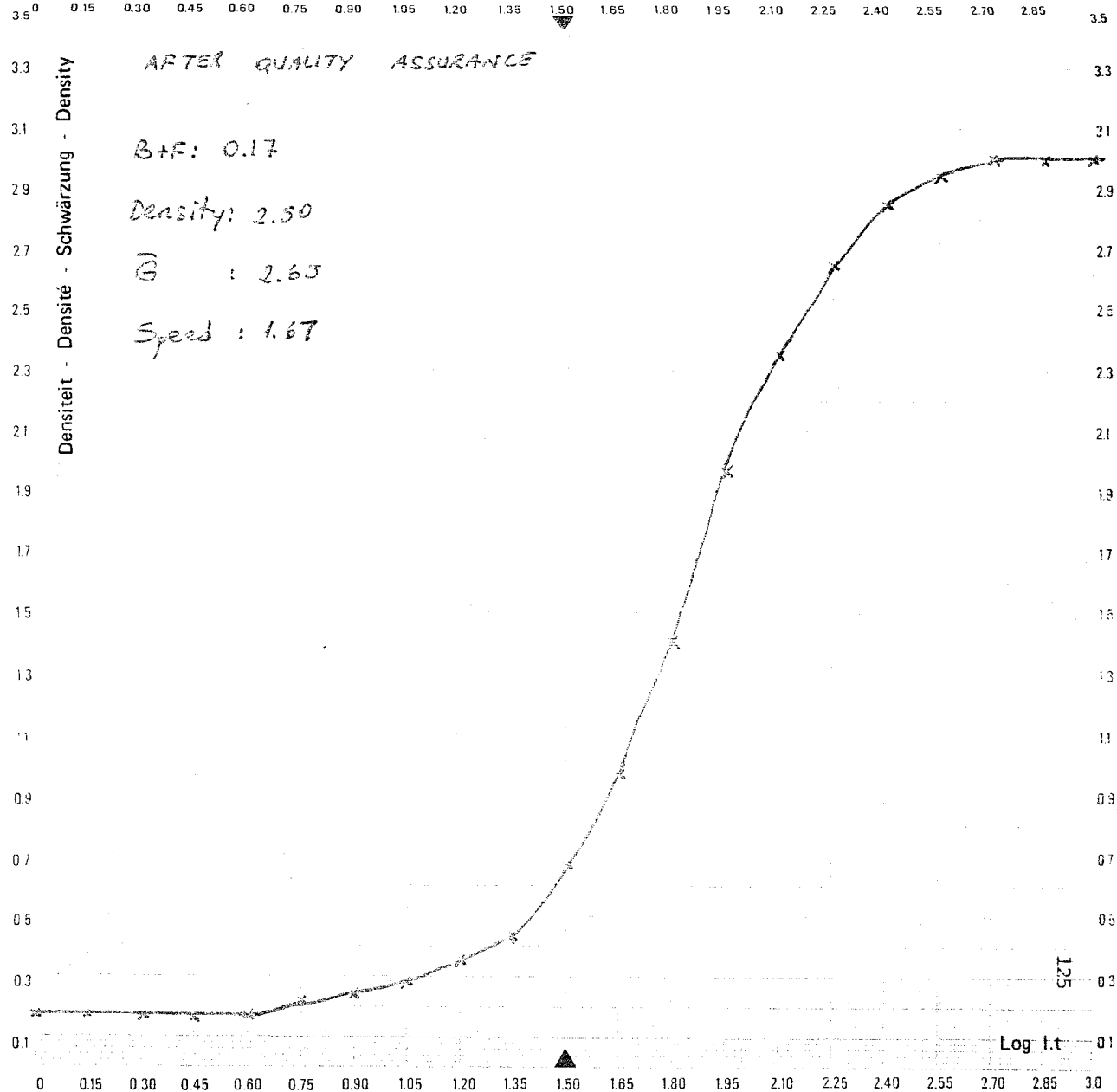



# AGFA-GEVAERT

KAART VOOR KWALITEITSCONTROLE  
 TABLEAU DE CONTROLE DE QUALITE  
 KARTE FÜR QUALITÄTSKONTROLLE  
 QUALITY CHECK CHART

Machine  
 Maschine  
 Processor **Nr**

Maand - Mois - Monat - Month		MAY																													
Dag - Jour - Tag - Day		01-31/1986																													
Vers ontwikkelbad - Révélateur frais - Frischer Entwickler - Fresh developer				x																											
Vers fixeerbadd - Fixateur frais - Frisches Fixierbad - Fresh fixer				x																											
Verse regenerator Régénérateur frais Frischer Regenerator Fresh replenisher	ontwikkelbad - révélateur - Entwickler - developer			x																											
	fixeerbadd - fixateur - Fixierbad - fixer			x																											
Sluier - Voile Schleier - Fog	Densiteit Densité Schwärzung Density	A																													
Index gevoeligheid sensibilité Empfindlichkeit speed	Densiteit Densité Schwärzung Density	B																													
Index contrast contraste Kontrast contrast	Densiteit Densité Schwärzung Density	C																													

CHAPTER VI.REFERENCES

1. Medical Imaging Systems Training Course by Agfa-Gevaert ,
2. Gray, J.E. "Photographic Quality Assurance In Diagnostic Radiology, Nuclear Medicine, And Radiation Therapy".  
HEW Publication (FDA) 76-8043 (June 1976).
3. Goldman, L. et.al. "Automatic Processing Quality Assurance: Impact on a Radiology Department". Radiol. 125: 591-595  
(December 1977)

## CHAPTER VII.

### SURVEY OF PROCESSORS IN ISTANBUL AREA

#### 7.1. INTRODUCTION

The purpose of this study is to compare the performance of film-chemistry-processor systems and specifically identify, where possible, the reasons for processing differences.

All the control films used in this study were AGFA CURIX RP-1. Gas system thermometer (accurate to within  $\pm 1^{\circ}\text{C}$ ) was used to measure chemical temperatures. Agfa strip papers were used in order to evaluate the pH and Ag levels of chemicals.

All the films were developed by the technicians of the facilities. No comment was given to them during processing of films. The techniques used in this study is the same to the ones used by the BRH of U.S.A. (1).

#### 7.2. THEORY

One 21-step log exposure versus density curve was generated for each facility. From this data B+F, speed step,

and average gradient were determined (Figure 7.1) in order to quantitatively characterize certain imaging parameters as a basis for comparison.

Speed varies inversely with the exposure necessary to produce a density of 1.0 above B+F density. This density is referred to as the speed density and the sensitometric step that is associated with the speed density is the speed step (Figure 7.1) (2). The sensitometer used is a  $\sqrt{2}$  sensitometer, i.e., each consecutive step increases the exposure to the film by a factor of the square root of 2 (1.41), and a speed step difference of two steps (i.e., from 10 to 12, or 11 to 13) would correspond to a two - fold ( $1.41 \times 1.41 = 2$ ) exposure difference. Logarithmically this would correspond to a log exposure difference of 0.15 between any two consecutive steps ( $\log \sqrt{2} = .15$ ).

Average gradient is a useful single number indicating the contrast property of a film (2). For medical X-ray films this value is defined as the slope of the straight line joining the two points corresponding to the net densities of 0.25 and 2.00 above B+F. Average gradient is characteristic of a film and increases with development time and developer temperature up to the point where the film is adequately developed. When dealing with traditional intensifying screens where the film darkening attributable to direct X-ray absorption by the film is negligible compared

to the light emission from the screen, average gradient is independent of the screen type and the X-ray beam quality to which the screen is exposed (4,5).

### 7.3. OBSERVATIONS

Figure 7.2 (a) shows the speed distributions for the control film (Agfa-Gevaert Curix RP-1) in both manual and automatic processor systems. A relative speed of 100 was assigned to the control film processed in Belgium. Processing speed, which is the figure representing the level of processing was calculated according to the formula:

$$\text{Processing Speed} = 10 \frac{(\text{Observed Speed Step} - \text{Reference Speed Step}) \times .15}{(\text{Reference Speed Step}) \times .15} \times 100$$

where  $10 \frac{.15}{.15} = 1.47$

As shown in Figure 7.2 (a) relative speed is mainly between 100 and 200. But, we can investigate that while some processing systems are relatively fast a great amount of them are relatively slow, thus causing underdeveloping. Therefore, more radiation dose for the given density level both to the patient and to the personnel.

If we compare the calculated values listed in the tables 7.1 and 7.2, the arithmetical means of relative speeds for both manual and automatic processing systems are 208.33 and 155.4 respectively. On the other hand, standard deviation in manual processing system is greater than that of in auto-

matic processing system.

Therefore, since the control sensitometric films used in the facilities are all in the same type and brand, observed variations are only attributable to the chemistry-processor systems rather than film differences.

The distribution of  $B\ddagger F$  values for the control film is shown in Figure 7.3 (a) (For both manual and automatic processing systems). The extreme values are highly suggestive of other than optimal processing conditions. Normal film aging and chemistry effects could not account for these observations alone. Examining Figure 7.3(a), (b), and (c) and Tables 7.1, 7.2 show us that  $B\ddagger F$  value differs greatly, therefore create an important problem for film processing. Although, the high  $B\ddagger F$  value is indicative of overprocessing, this is because of high developer temperature, old chemistry and light fog in the darkroom. Thus causing underdeveloping of the film.

Figures 7.4 and 7.5 show that the values are lower than expected values. Since temperature and time are controlled automatically and constant during film processing in automatic processing systems, the values are close to the expected values and deviate less than in manual processing systems. The low average gradient and density range values for both processing systems, strongly correlate with the lower relative speed and highly suggestive of underprocessing.

7.4. COMPARAISION WITH THE STUDY CONDUCTED IN THE STATE OF  
NEW JERSEY

The same study was also conducted in the State of New Jersey(1). The techniques used are the same. The main difference between these two studies is that the study in the State of New Jersey was conducted with various types of films.

Response of Agfa-Gevaert Curix RP-1 control film when processed in the State of New Jersey and in automatic and manual systems in the Istanbul area are as follows:

Study Conducted In	B+F (1 S.D.)	Relative Speed (1 S.D.)	Average Gradient (1 S.D.)	N
The State of New Jersey	.19(.04)	127(29)	2.40(.30)	27
Manual Process- ing Systems In The Ist. Area	.22(.15)	208.3(84)	1.98(.49)	21
Automatic Processing Sys- tems In The Ist. Area	.21(.04)	155.4(31.8)	3.05(.33)	10

(S.D.- Standard Deviation)

For simplicity, let's denote the study in the State of New Jersey as (A) and the study in the Istanbul area as (B), (C) for manual and automatic processing systems respectively.

Base plus fog level is  $.19(.04)$  in (A) and that of (B) and (C) are  $.22(.15)$  and  $.21(.04)$  respectively. This indicates that B+F level is a problem in Turkey. B+F value is greater than the average values ( $.15-.20$ ). In addition to this problem, B+F value differs a great deal especially where manual processing systems are used. The high B+F levels indicate the presence of improper light bulbs, and filters as well as light leaks.

Relative speed is  $127(29)$  in (A),  $208.3(84)$  and  $155.4(31.8)$  in (B) and (C) respectively. These figures are indicative of low speed, thus underprocessing of radiographic films in most processors in Turkey. Furthermore, high standard deviation is indicative of no consistency in speed.

Average gradient is  $2.40(.30)$  in (A) and  $1.98(.49)$  and  $3.05(.33)$  in (B) and (C) respectively. Underprocessing of radiographic films and having no consistency especially in manual systems in Turkey are apparent with these figures.

The reasons of these above mentioned problems can be summarized as;

Having no quality assurance programmes, recommendations and standards in Turkey.

Therefore;

- 1- Technologists do not use time-temperature tables
- 2- Old chemicals are used in the processor systems

- 3- There is no daily replenishment of developer and fixer
- 4- Technologists check contrast level of films on sight.

Thus, high B $\dagger$ F level, low contrast level and low speed are common problems in film processing in Turkey.

By poor utilization of X-ray films, the cost effectiveness of the center decreases, diagnostic information is lost and radiation dose given to the patient and technologist increases. The solution to these problems are relatively easy to implement and has been discussed in chapters 4 and 5;

- 1- Proper design of the darkroom,
- 2- Proper film processing techniques,
- 3- Using the proper processor chemicals,
- 4- Implementation of a quality assurance programme.

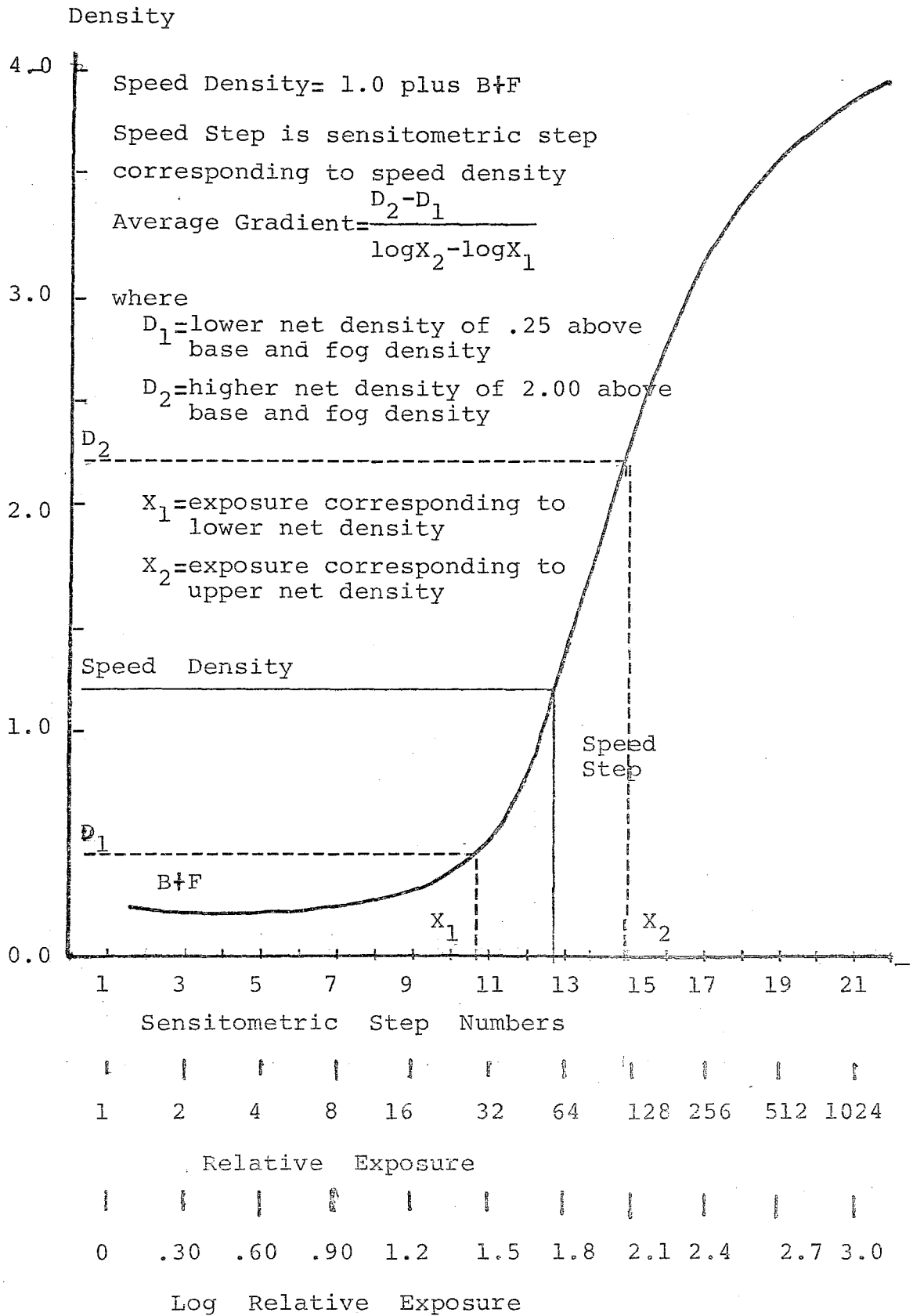

Figure 7.1. Characteristic Curve of Film With Sensitometric Indices

TABLE 7.1: MANUAL PROCESSING SYSTEMS

CODE	SPEED	RELATIVE SPEED	AVERAGE GRADIENT	DENSITY RANGE	BASE + FOG	FOG TEST
1	1.70	169	1.85	1.90	.80	F
2	1.76	194	1.90	2.02	.16	O.K
3	1.68	162	2.40	2.26	.15	O.K
4	1.85	239	2.45	2.36	.15	F
6	2.00	338	1.00	1.80	.30	F
8	1.78	204	1.48	2.10	.15	O.K
9	1.90	269	1.46	1.60	.38	F
12	1.55	120	1.45	2.20	.20	F
16	1.83	229	2.10	2.12	.15	O.K
19	1.68	162	2.00	2.01	.20	F
20	1.64	147	2.37	2.35	.20	F
23	1.85	239	1.96	2.00	.15	O.K
24	1.60	134	2.60	2.62	.18	O.K
25	1.66	154	2.05	2.00	.30	F
26	1.58	129	2.40	2.28	.25	F
27	1.98	324	1.50	1.60	.12	O.K
28	1.75	191	2.08	2.07	.18	F
29	2.12	447	1.35	1.70	.12	F
30	1.57	126	3.00	2.60	.18	F
31	1.89	263	1.90	1.80	.15	O.K
32	1.60	135	2.38	2.52	.20	F

Number of

data : 21 21 21 21

Arithmetical

mean : 208.3 1.98 2.09 .22

Sum of value : 4375 41.68 43.91 4.67

Population

St. dev. : 81.94 .48 .29 .14

Sample St.dev.: 84 .49 .30 .15

TABLE 7.2: AUTOMATIC PROCESSING SYSTEMS

CODE	SPEED	RELATIVE SPEED	AVERAGE GRADIENT	DENSITY RANGE	BASE ‡ FOG	FOG TEST
5	1.73	181	2.82	2.69	.19	O.K
7	1.78	204	3.80	2.46	.19	O.K
10	1.72	178	3.00	2.70	.27	F
11	1.68	162	3.10	2.91	.28	F
13	1.68	162	2.83	2.44	.20	O.K
14	1.42	89	3.40	3.10	.27	F
15 <sup>‡</sup>	2.17	501	1.10	1.60	.22	F
17	1.63	144	2.90	2.72	.17	F
18	1.68	162	3.10	2.72	.16	O.K
21	1.63	144	2.65	2.57	.20	F
22	1.58	128	2.90	2.60	.20	O.K

Number of data	:	10	10	10	10
Arithmetical mean	:	155.4	3.05	2.69	.21
Sum of value	:	1554	30.05	26.91	2.13
Population					
St. dev.	:	30.13	.316	.19	.041
Sample St. dev.:		31.8	.33	.20	.043

15<sup>‡</sup> : included in the histograms, but not in the calculations

Figure 7.2 (a): SPEED DISTRIBUTION  
(Among 32 Systems)

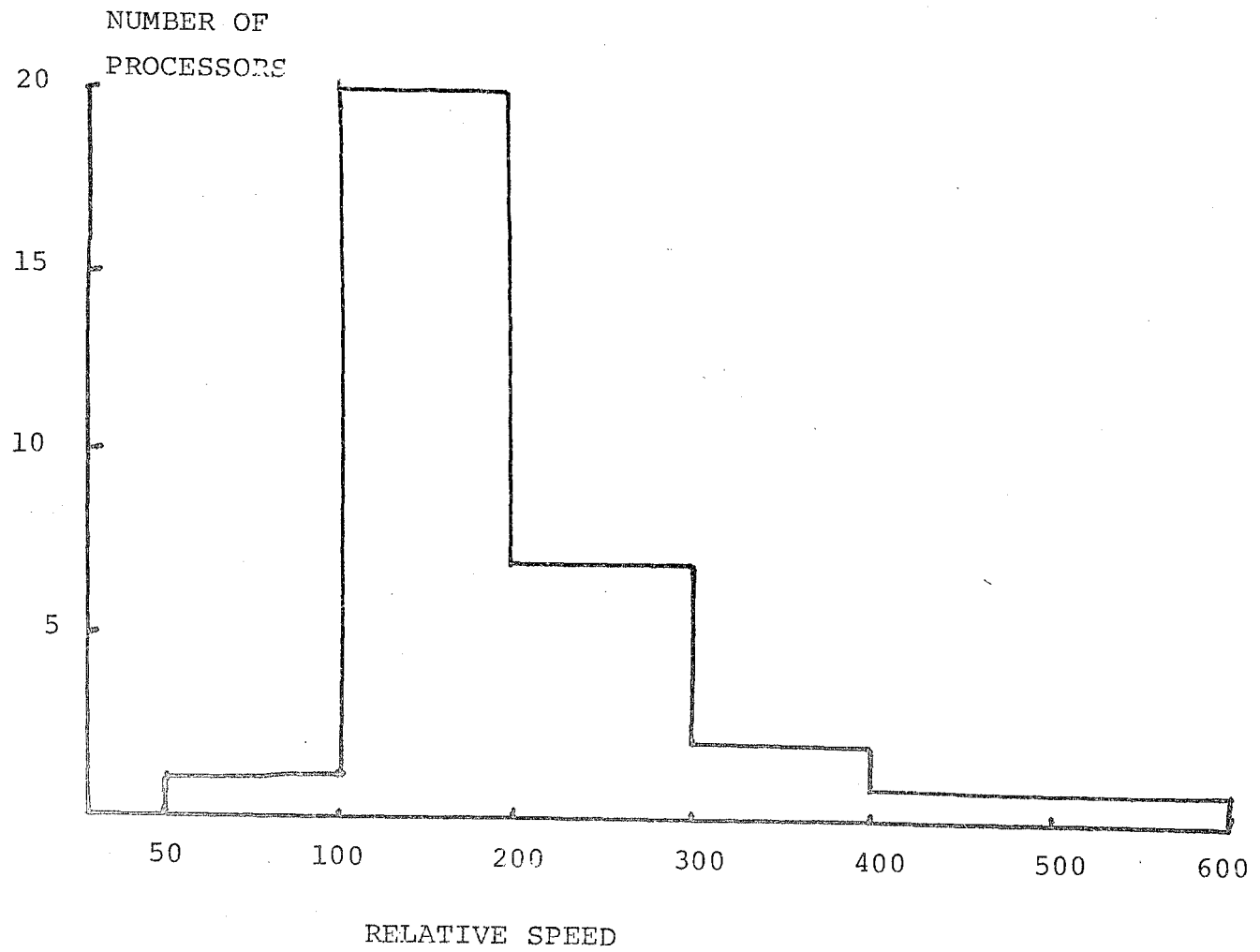

Figure 7.2 (b) : SPEED DISTRIBUTION  
(MANUAL-Among 21 Systems)

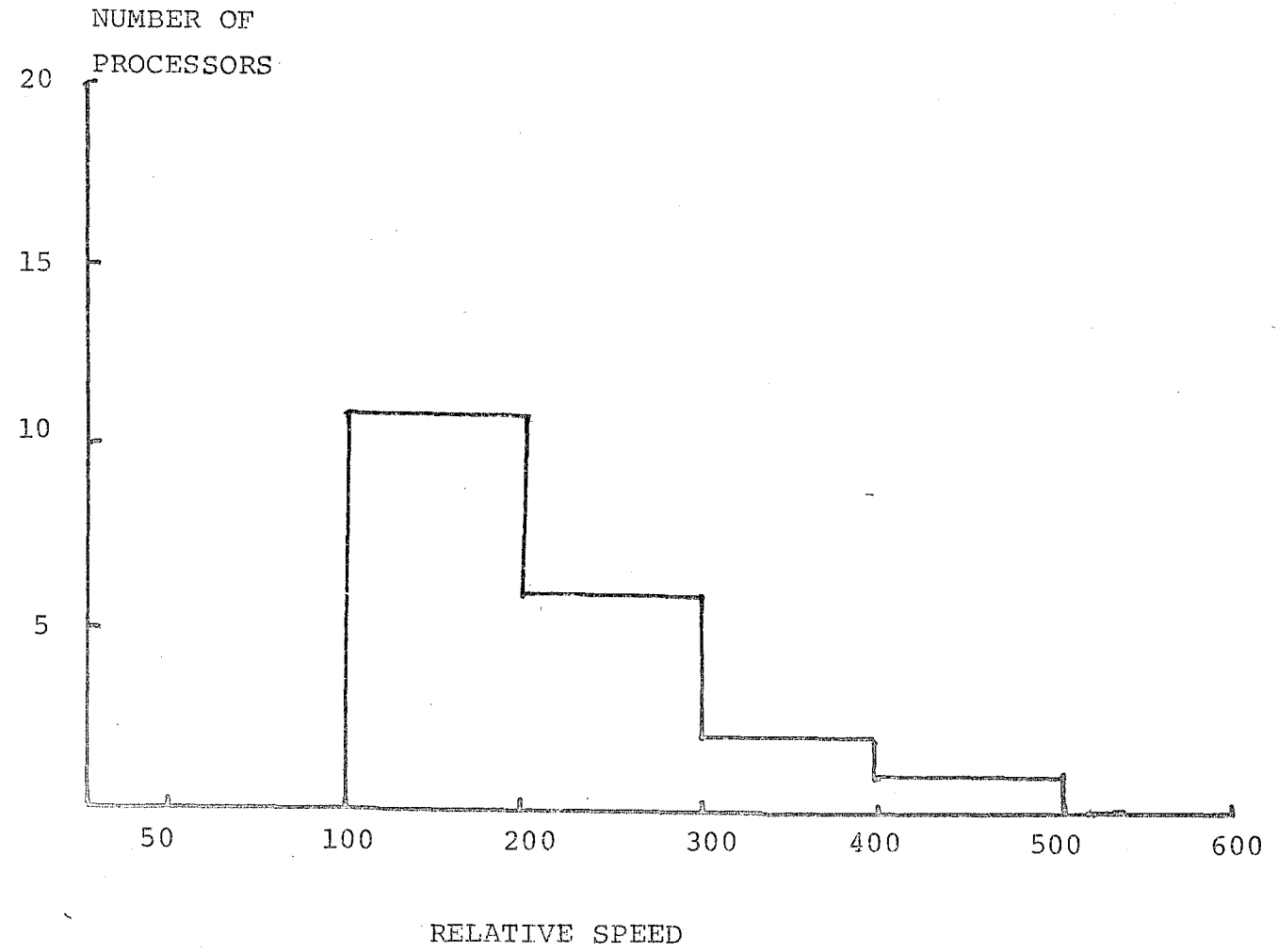

Figure 7.2 (c) : SPEED DISTRIBUTION  
(AUTOMATIC -Among 11 Systems)

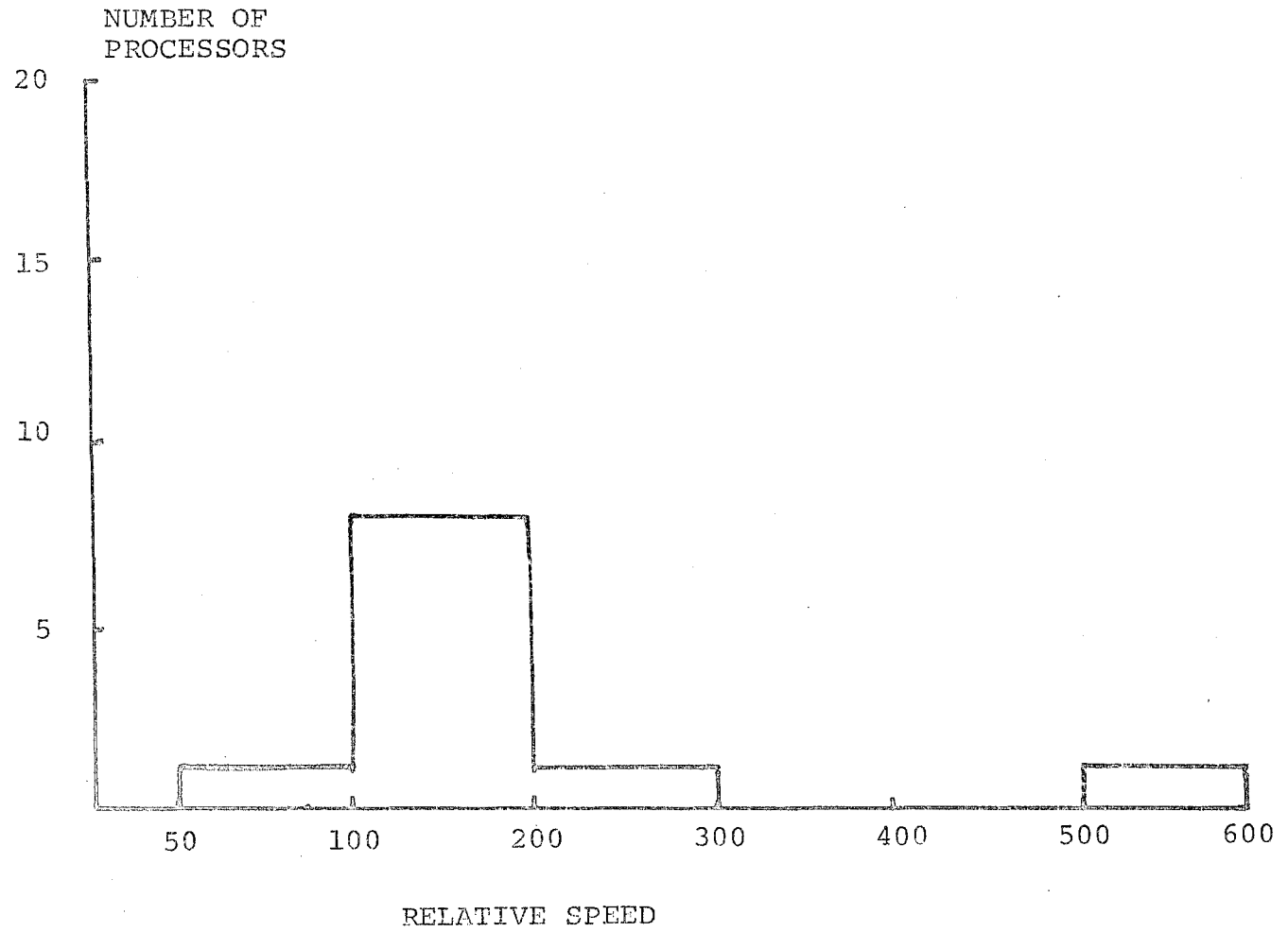

Figure 7.3 (a) : BASE AND FOG DISTRIBUTION  
(Among 32 Systems)

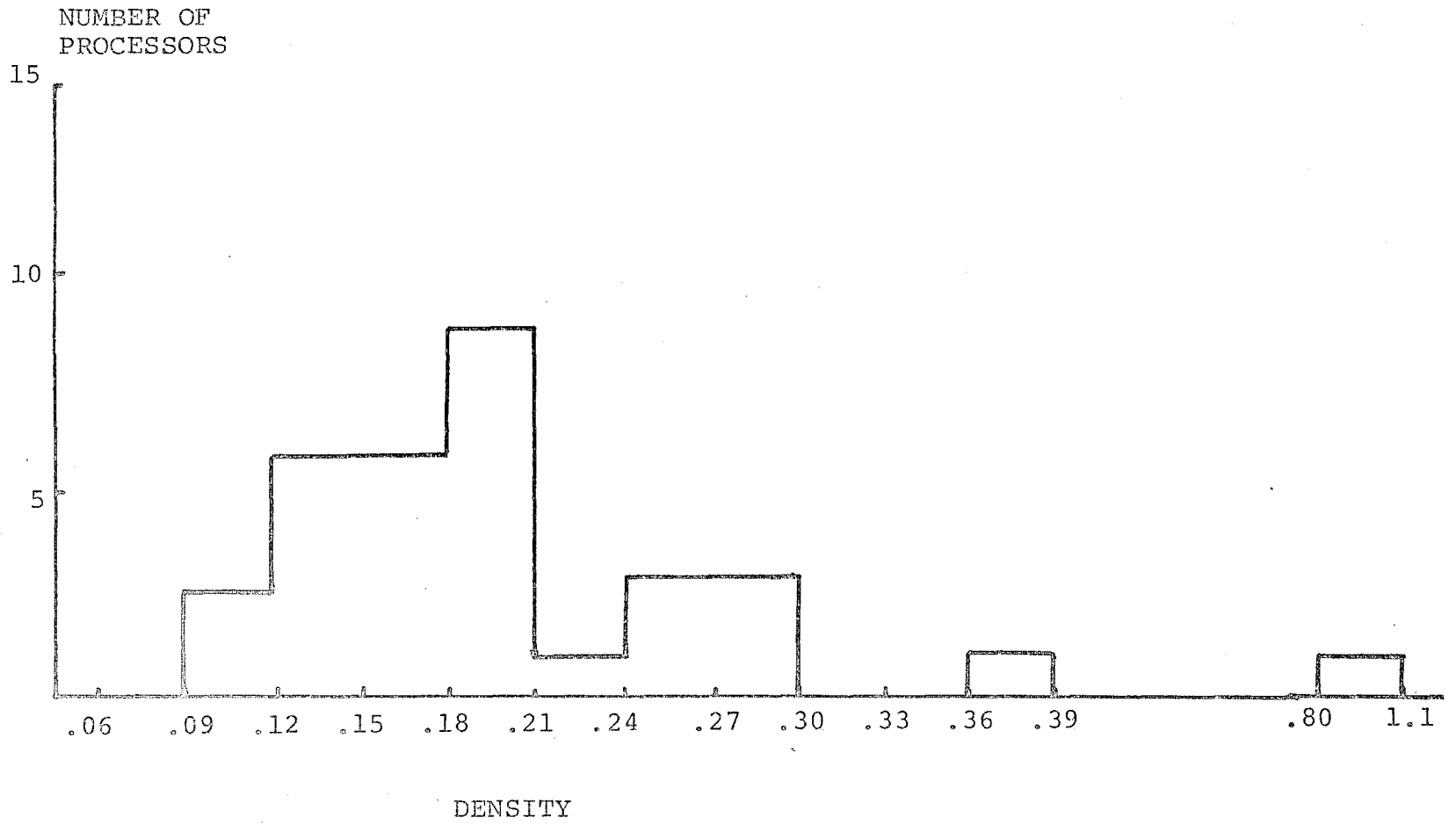

Figure 7.3 (b) : BASE AND FOG DISTRIBUTION  
(MANUAL -Among 21 Systems)

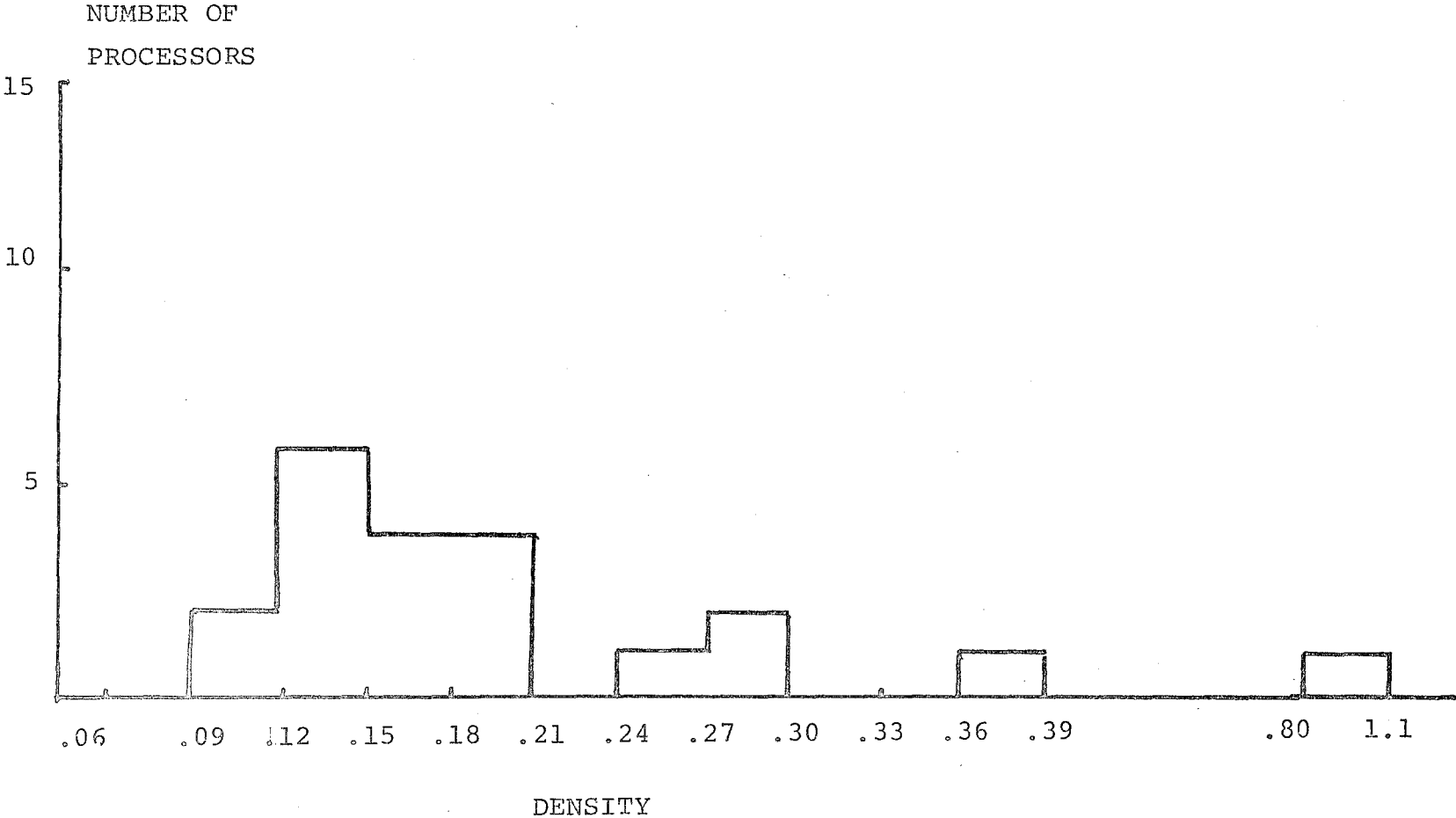

Figure 7.3 (c) : BASE AND FOG DISTRIBUTION  
(AUTOMATIC -Among 11 Systems)

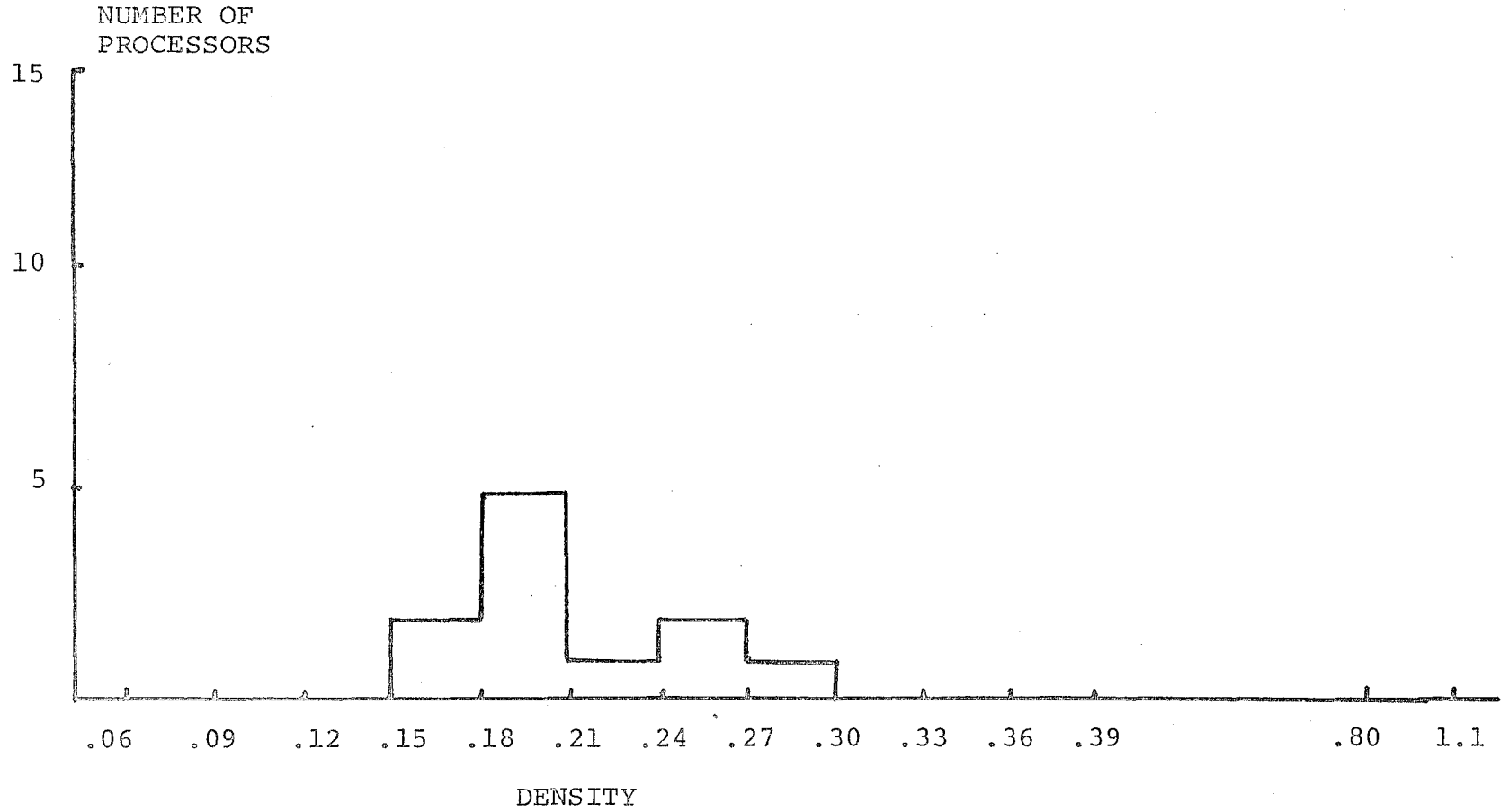

Figure 7.4 (a) : AVERAGE GRADIENT DISTRIBUTION  
(Among 32 Systems)

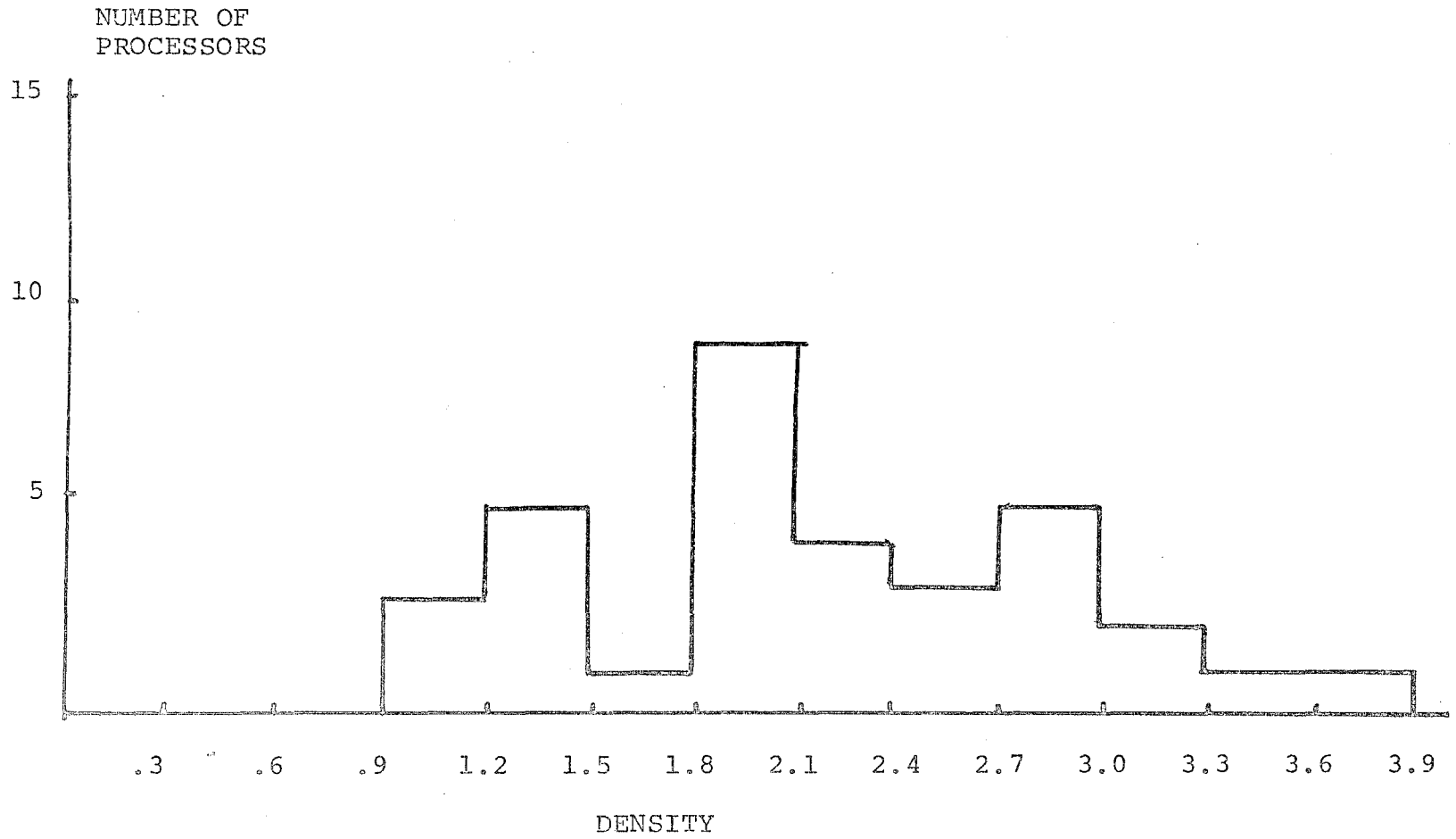

Figure 7.4 (b) : AVERAGE GRADIENT DISTRIBUTION  
(MANUAL-Among 21 Systems)

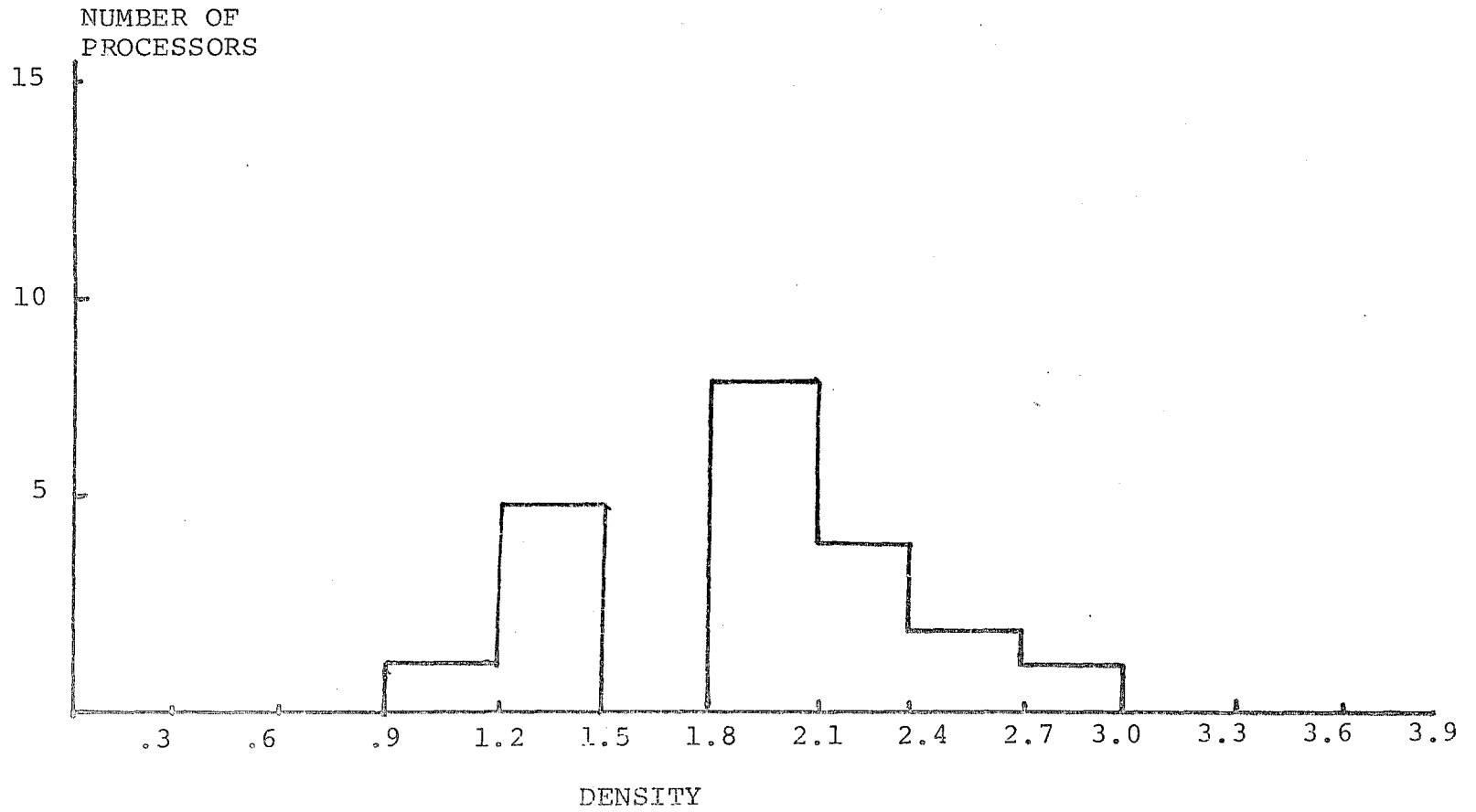

Figure 7.4 (c): AVERAGE GRADIENT DISTRIBUTION  
(AUTOMATIC -Among 11 Systems)

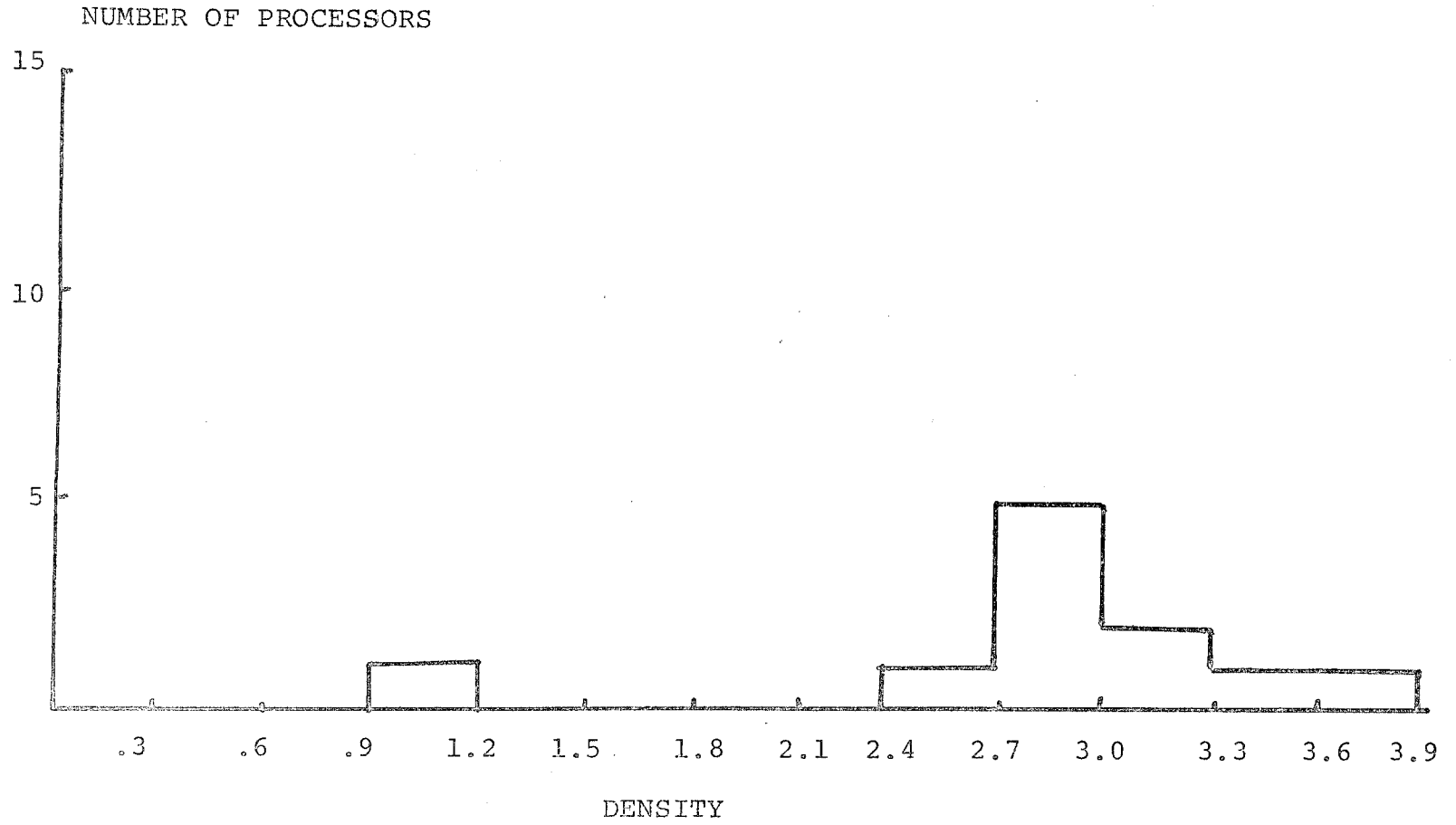

Figure 7.5 (a) : DENSITY RANGE DISTRIBUTION

(Among 32 Systems)

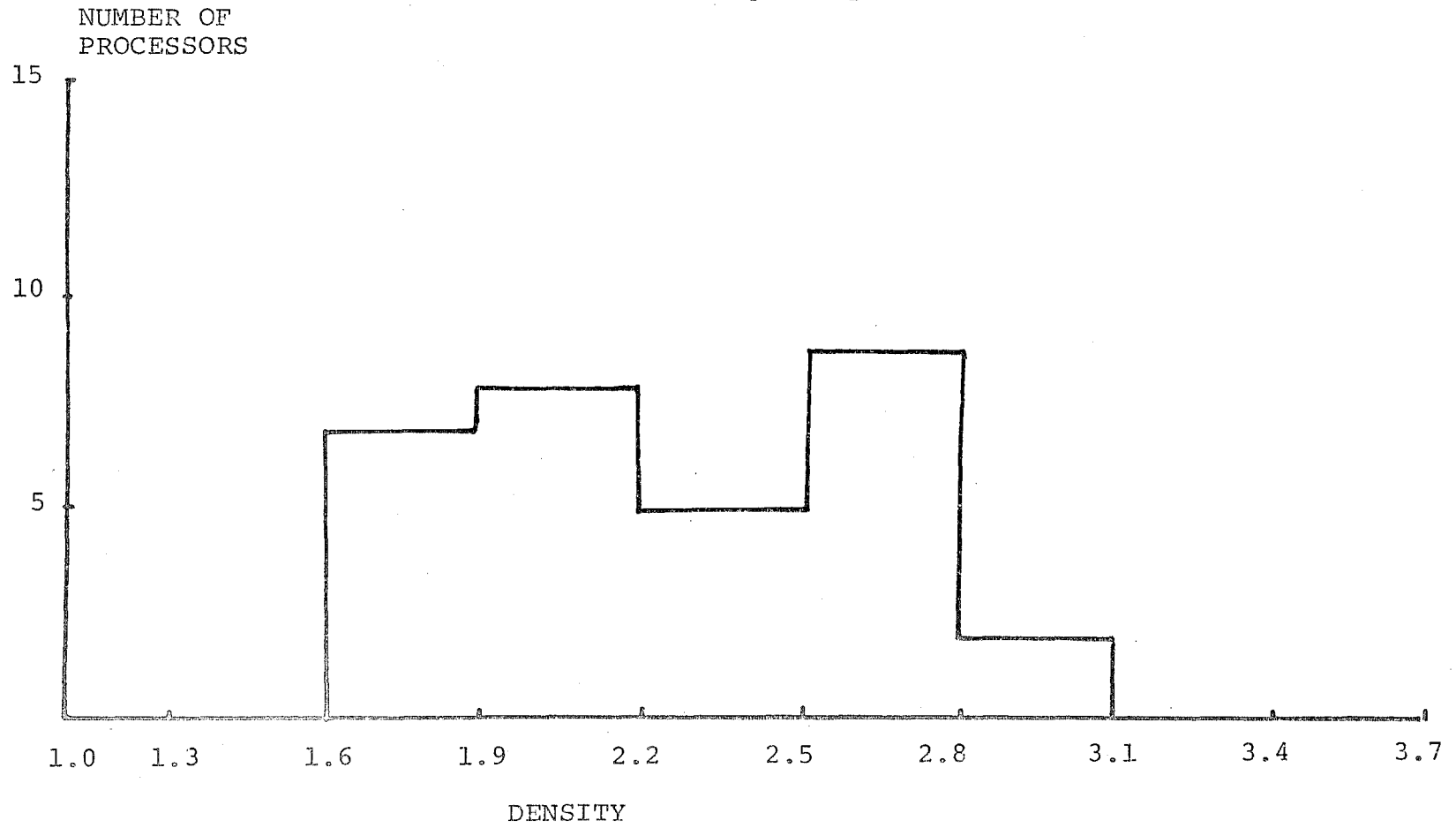

Figure 7.5 (b): DENSITY RANGE DISTRIBUTION

(MANUAL -Among 21 Systems)

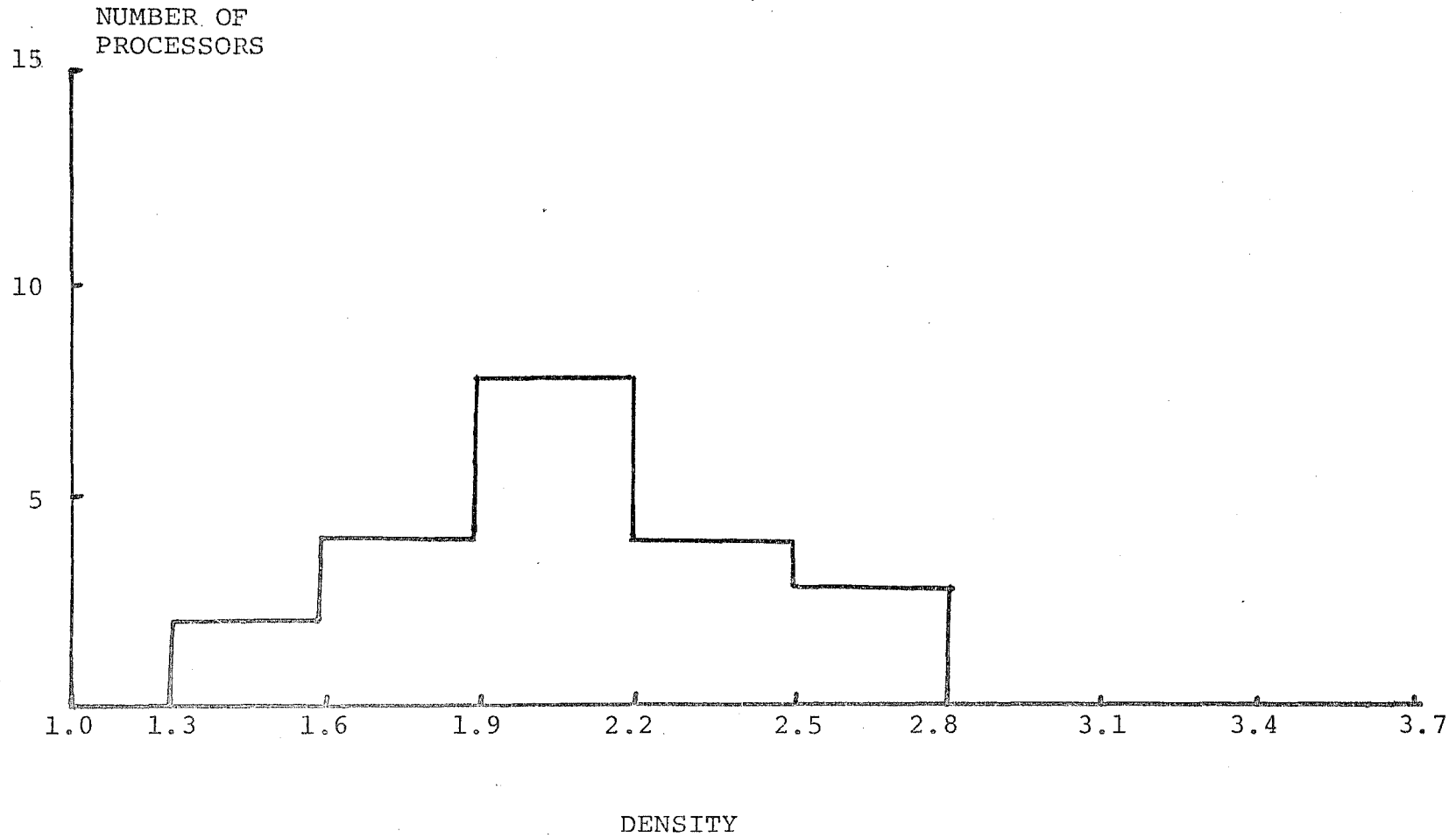
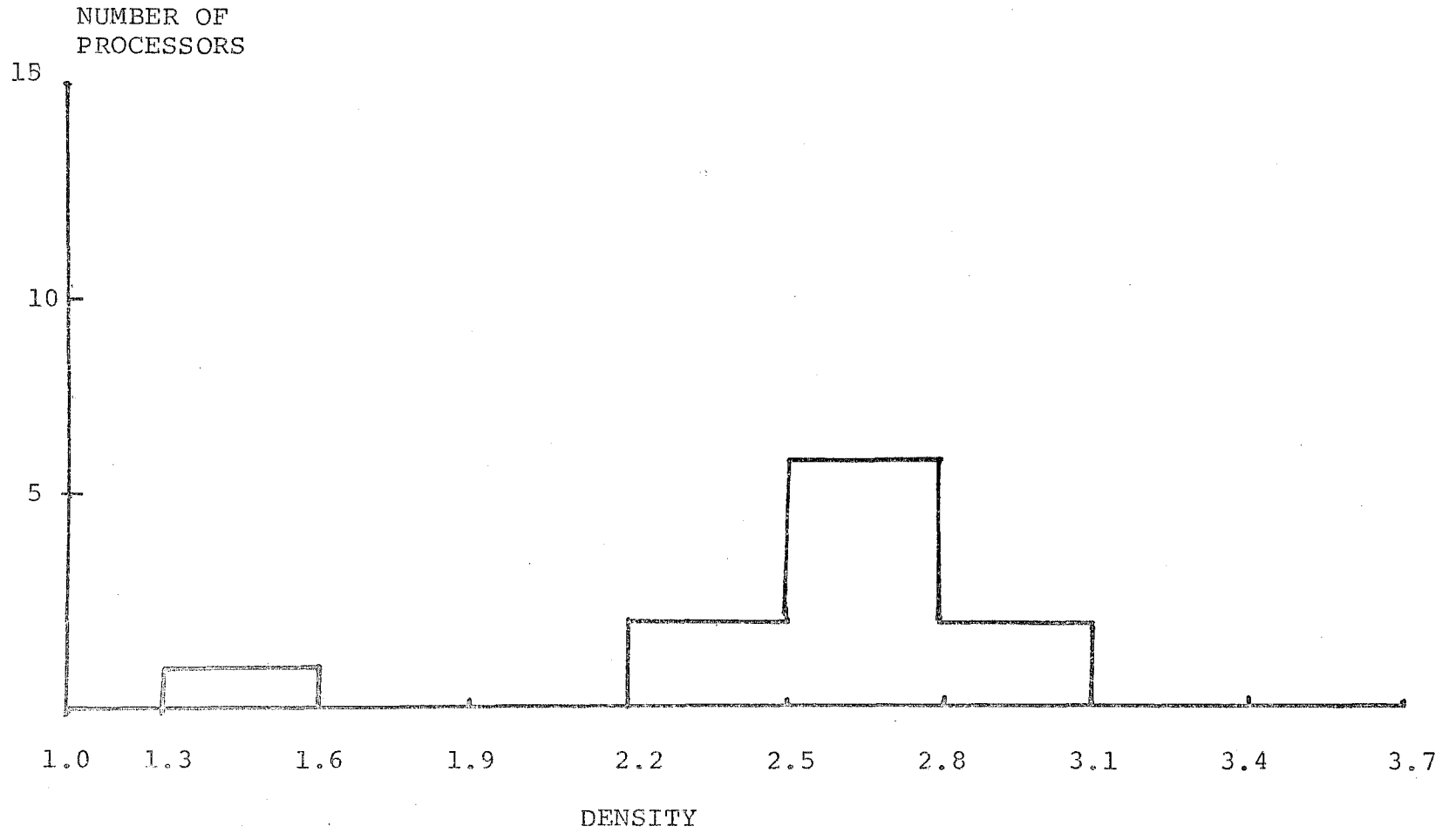

Figure 7.5 (c) : DENSITY RANGE DISTRIBUTION  
(AUTOMATIC -Among 11 Systems)



CHAPTER VII.REFERENCES

1. "A Sensitometric Evaluation Of Film-Chemistry-Processor Systems In The State Of New Jersey" U.S. Department Of Health and Human Services, Public Health Service (FDA) BRH Rockville, Maryland 20857 (April 1982).
2. "Sensitometric Properties Of X-Ray Films". Eastman Kodak Co., Rochester, New York. 14650 (MI-2) 7-72 - AX.
3. Kodak Film/Screen Combinations, Eastman Kodak Company, Health Sciences Markets Division, Rochester, N.Y. 14650 (M3-138) (July 1979).
4. Bates, L.M. "Some Physical Factors Affecting Radiographic Image Quality: Their Theoretical Basis And Measurement". Public Health Service, Publication Number 999-RH-38 (1969).
5. Rao, G.U.V., P.P. Fatouros, and A.E. James, "Jr. Physical Characteristics Of Modern Radiographic Screen - Film Systems". Invest. Radiol. 13:460 - 469 (September - October 1978).
6. Patterson, J.F., O.H. Suleiman, and D. Mc Kenna. "Comparison Of Processing Variations On Different Film/

Chemistry Combinations". In: Proceedings Of The Health Physics Society Fourteenth Mid-Year Topical Symposium, pp 355-364, Dec. 8-14, 1980.

7. Goldman, L., et. al. "Automatic Processing Quality Assurance: Impact On A Radiology Department." Radiology 125: 591-595 (December 1977).
8. Cleare, H.M. and G.A. Trumbauer. "An Analysis Of Variability In Radiographic Image Recording. Second Image Receptor Conference: Radiographic Film Processing". In: Proceedings Of a Conference Held In Washington, D.C. March 31- April 2, 1977, HEW Publication (FDA) 77-8036 pp 11-23 (August 1977).
9. R. Burkhart. "Quality Assurance Programs for Diagnostic Radiology Facilities", HEW Publication (FDA) 80-8110, U.S. Department of Health, Education and Welfare 1980.
10. T.C. Barber, J.M. Thomas, "Radiologic Quality Control Manual, Reston Publishing Company, 1983".

## CHAPTER VIII.

### FILM STORAGE AND HANDLING

#### 8.1. STORAGE CONDITIONS

The properties, such as speed and contrast, of any sensitized photographic material deteriorate with time. Therefore, the conditions under which all sensitized radiographic and photographic materials are stored is critical (1).

The relative humidity in the film storage area should be maintained between 40 and 60 percent. If the humidity is maintained at these levels throughout your department, you will see a significant reduction in static discharge artifacts which are characteristics of low humidity areas (1,4).

Maximum shelf life can be obtained if films are stored between 10°C and 22°C at 40-60 percent relative humidity, in an area free from chemical fumes and at low background radiation levels. (7).

Moisture in the air will condense on any cold material, therefore sensitized materials should be brought to room temperature before opening the sealed, moisture resis-

tant container. It is advisable to leave the unopened box of film on a shelf at room temperature for at least 8 hours.

Two basic rules are as follows; (1)

1. Do not purchase more films than can be stored under the proper conditions of temperature and humidity.
2. Photographic film and chemicals should NEVER be stored at temperatures in excess of 27°C for any length of time.

### 8.2. FROZEN STORAGE CONDITIONS

Freezing of film at -18°C virtually stops the deterioration which normally takes place in photographic materials. However, photographic chemicals should never be frozen. Since freezing prevents deterioration of photographic and radiographic films, the expiration date on the box only indicates a relative date. For example, if your box of film has an expiration date on it of June 1986 and you place the film in the freezer in August 1985, you have 6 months of shelf life remaining. However, since the deterioration is virtually halted, you will have a 6-month shelf life left after you remove the film from the freezer regardless of whether or not it is after expiration date.

A minimum of 24 hours should be allowed for a single 100-sheet box of frozen film to reach room temperature before opening.

### 8.3. RADIATION LEVELS IN STORAGE AREAS

The major cause of film fog during shipping is high temperature storage conditions (above 27°C). Ionizing radiation is the second major cause of film fog during shipment while it is the primary cause of fog during storage in the radiology department. Photographic and radiographic films should never be stored in the vicinity of radioactive materials or waste ever for short periods of time. (2,4).

Figure 8.1 shows the maximum storage time as a function of background radiation.

The maximum amount of time that sensitized radiographic or photographic materials may be stored depends on the background radiation level. This background radiation must include all sources of radiation from examining rooms and other sources within the department.

The best approach is to test the storage area for

radiation with the film to be stored in that area. Place one sheet of each type of film stocked in the storage area in a light tight envelope partially between two lead blocks. If the film shows a visual increase in density, or a measurable change in density of 0.02, in the area not protected by lead blocks over a period of 6 months, or the normal maximum storage time for your film, then the area is not safe for film storage and a lower radiation level area should be used (1).

#### 8.4. FILM HANDLING

Some of the most persistent and baffling problems related to the appearance of radiographic artifacts are associated with the improper handling of film. (7)

The most common artifact is the so-called kink, crinkle, or half-moon mark. (See Figure 8.2) It can occur if a sheet of film is allowed to bend in a manner shown in Figure 8.3.

The excess pressure exerted at the point where the film buckles results in the crinkle mark.

Do not draw film rapidly from cartons, exposure holders, or cassettes, or handle it in any manner that would cause static electrical discharges. Care in this regard will avoid one common cause of objectionable circular or treelike blackmarks on radiographs.

Maximum storage time (months)

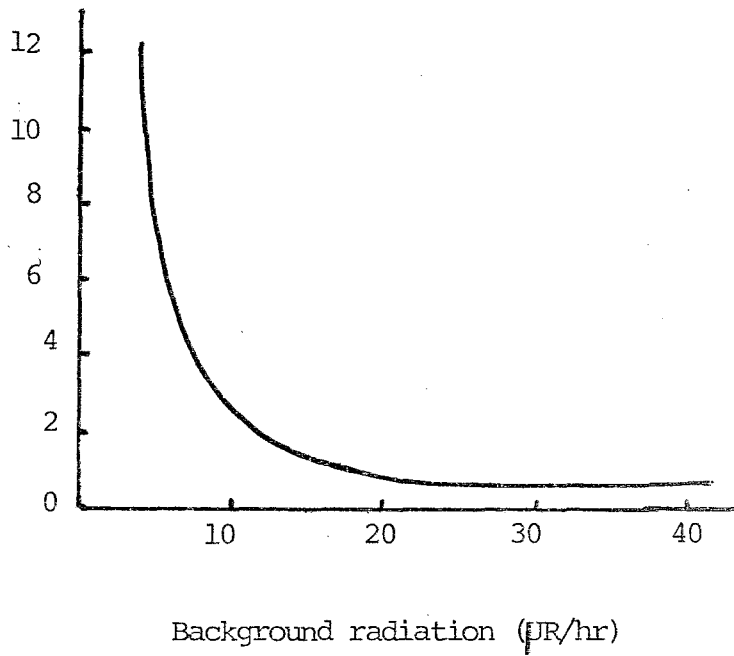
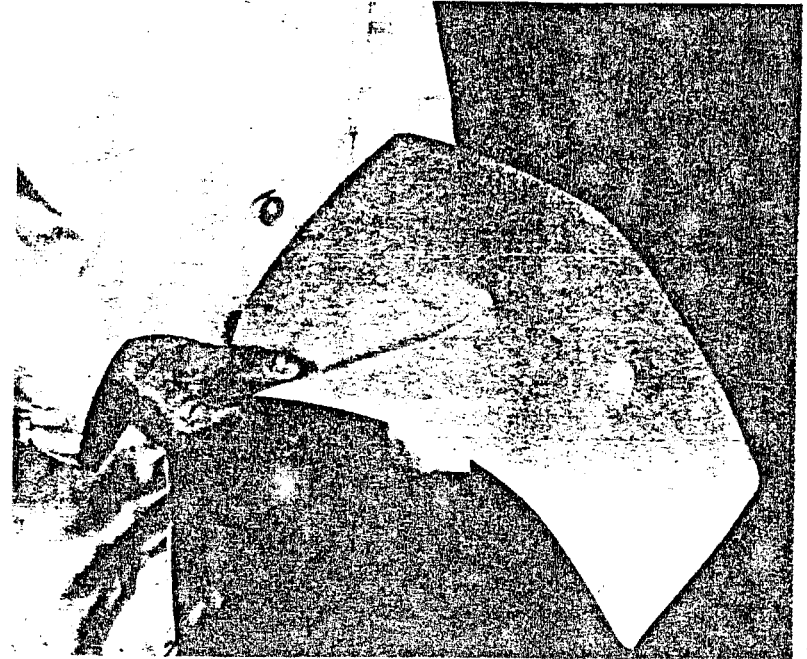

Figure 8.1 : Maximum storage time as a function of background radiation.



A

FIG.8.2 *continued*



B

FIG.8.2. (A) Both of the images in this radiograph (arrows) were caused by mishandling the film. The single arrow demonstrates a crinkle mark, which can occur if the film is bent in the manner shown in B. The double arrows show an artifact caused by exerting pressure on the surface of the film.



◁ FIG 8.3. The artifact seen in this radiograph (arrow) is called a kink, crinkle, or half-moon mark. In this case the black mark appears on a film that had not been exposed to x-ray.

FIG. 8.4  
continued

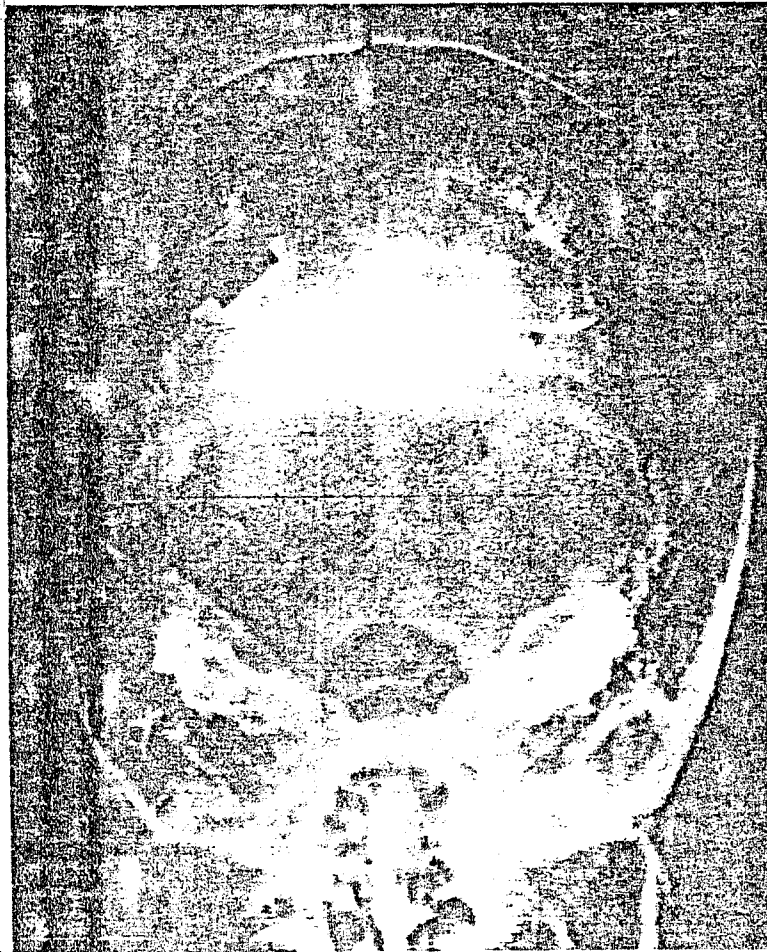

FIG. 8.4 • (A) The crinkle-type artifactual image (arrow) in this radiograph of the skull was mistaken by an emergency-room physician for a fracture. (B) A repeat examination the following day revealed the pseudofracture to be artifactual.

CHAPTER VIII.REFERENCES

1. Joel E. GRAY Edward Christie Stevens Research Fellow in Radiological Sciences. Radiological Research Laboratories, University of Toronto, Canada. Photographic Quality Assurance in Diagnostis Radiology, Nuclear Medicine, and Radiation Therapy Volume I The Basic Principles of Daily Photographic Quality Assurance. Hew Publication (FDA) 76-8043 .
2. The Fundamentals of Radiography Eastman Kodak Company, Rochester 4, N.Y. 10th. edition.
3. "Products For Medical Diagnostic Imaging", Pub. No. M5-15 p. 15, Rochester, Eastman Kodak, 1981.
4. Thompson TT: "Cahoon's Formulating X-Ray Techniques", 9th ed, pp 31-33. Durham, Duke University Press, 1979.
5. Henny GC: "Artifacts In Roentgen Films". Radiology 24, No. 3: 350-356, 1935.
6. Kane IJ: Artifacts Simulating minimal tuberculosis AJR.66 No. 5: 803-807, 1951.

7. "Processing and Handling of Medical X-Ray Films" Pub.

No XM3-3E, p4, N.Y. Fuji Photographic Film, 1978.

## CHAPTER IX.

### HOW TO PURCHASE RADIOGRAPHIC MATERIALS

The major two problems will always be present whenever photographic materials are used.

i) Selecting the best film for your department from the many types of radiographic films that are available (In Turkey, there is always one type of X-ray film selected by Kızılay with tender. So, there is no opportunity for the end user to select film type).

ii) Radiographic film received in your department should be in good condition and should not be degraded by radiation or heat fog. (5).

#### 9.1. EVALUATION OF SENSITIZED RADIOGRAPHIC MATERIALS

Evaluations of radiographic materials must be made using carefully selected techniques that allow for the use of a standard X-ray source and the appropriate intensifying screens. (4) The results you obtain may not be applicable in another department, under slightly different conditions (such as different  $kV_p$ ), or with a different generator.

The first thing you will need is an aluminum step

edge. (5) The wedge should be constructed with  $1/8$ " steps so that the thickness of the steps are  $1/8$ ",  $1/4$ ",  $3/8$ ",  $1/2$ ", etc. Each step should be 3" wide by  $1/2$ ". The wedge should contain a minimum of 12 steps with the thickest being  $1-1/2$ " thick, or preferably 14 steps with the thickest being  $1-3/4$ ". For convenience a  $1/4$ " diameter hole should be drilled into the sixth step (of the 12 step wedge) or seventh step (of the 14 step wedge) to approximately one-half of the thickness of the step. This will serve as an identifying marker on the exposed films.

Since the heel effect is significant with most X-ray tubes, a focal spot to film distance of 2 meters is recommended. (7) In addition the step wedge should always be radiographed in the identical location in the beam. For this purpose you should mark the step wedge - with the words "anode" and "cathode" signifying the ends of the wedge which correspond to the anode and cathode ends of the tube. In addition, a crossed line should be drawn on the sixth or seventh step which will indicate the position of the collimator cross hairs when the wedge is radiographed.

The technique you select is not too important as long as you bear a few basic facts in mind. First of all, you should make all of the necessary exposure with the mA,  $kV_p$ , and time fixed before making any changes in the generator. The same generator should be used for all of your

work. (5, 7)

Since you are radiographing an aluminum step wedge, the contrast you measure on the film will depend on the  $kV_p$  used and the amount of scatter radiation, as well as other factors. Consequently, one  $kV_p$  should be selected and the radiograph should be collimated so that approximately 1" of film is exposed around the entire step wedge. This area can be used for lead marker identification which is essential in this type of evaluation. You should record the  $kV_p$ , mA, and exposure time as well as film type, screen type, focal spot to film distance, and anode-cathode orientation on each film.

If you want to repeat exposures in the future with reasonable accuracy, it will be necessary to set the mA and exposure time at fixed values rather than relying on setting just the mAs.

The technique should be chosen so that the step wedge produced on the processed film provides the optimum amount of information. The lightest step on the film should be approximately at the base-plus-fog level of the film which would place the darkest step on the film at a density of approximately 3.0 or greater. An important point to note here is that the darkest step on your exposed film will not be the step under the thinnest step of the wedge but rather

the area of the film beyond the thinnest step i.e., that part of the film exposed to raw radiation. Consequently, you should be sure not to put identifying markers in the exposed area adjacent to the thinnest step on the wedge. This means that your 14-step wedge will actually provide 15 different density steps on the film plus the base-plus-fog level which is measured on a section of the film which received no radiation exposure. (3, 5)

In comparing two types of film, in order for two test films to receive the same exposure we can radiograph one step wedge on both films at the same time. This can be accomplished very simply by cutting 18x24 cm. sheets of the film in half to form 9x24 cm. strips. (Code one of the film types with a paper punch to avoid confusing the types of film in the darkroom and after processing). Place one 9x24cm. sheet of each type of film in the cassette side by side and make the radiograph with the aluminum step wedge centered over the two sheets so that half of the step wedge image falls on each sheet of film. After the 9x24 cm. films have been exposed, they should be processed side by side in the processor with the two exposed areas adjacent. The most important point to remember is that films must be exposed simultaneously. (5)

At least three exposures should be made with the same technique, step wedge and screen-film combinations. At

least 2 minutes between exposures should be waited in order to avoid overheating of X-ray tube. So that the deviations of exposure settings ( $kV_p$ , mAs) would be minimized. Each pair of films should be processed immediately after exposure. The 15 (or 13) densities and B+F level for all three sets of film should be read; the corresponding densities for each film type should be averaged.

The densities should be plotted in order to determine the relative speed and contrast for the two films (Figure 9.1)

The thickest part of the aluminum wedge will produce the lightest densities on the wedge and the thinnest part of the wedge will produce the darkest densities on the film. In the example (Figure 9.1) it can be seen that Film A produce more darkening for the same thickness of aluminum than Film B. In addition, the slope of the curve for Film A is much steeper than for Film B. In order to compare the relative speed and contrast of these two hypothetical radiographic films, it will be necessary to measure certain points on these curves.

We will define the speed point as the thickness of aluminum which produces a density of 1.0 above the B+F level of the film. For example, the speed point of Film A is 1.14 inch Al and the speed point of Film B is 0.93 inch Al. The thickness difference (TD) between these two points provides

an indication of the speed difference between the two films.

$$1-14" - 0.93" = 0.21 = TD$$

Figure 9.2 gives an approximation of the speed factor (SF) between the two films. The TD of 0.21" produces a speed factor of approximately 1.80. This means that Film A is 1.80 times faster than Film B since Film A's curve lies to the left of Film B's.

Figure 9.2 provides the numerical values for the speed factor; i.e., the difference in speed between two films, as a function of the difference in the thickness of aluminum (from Figure 9.1) which produced the specified density of 1.0 above the B+F level of the film. The correction factor is the multiplier used to change the mAs when a new, higher speed screen film is to be used. This means that in order to obtain a radiograph with Film A, of approximately the same density as with Film B, it will be necessary to reduce the mAs to 0.56 of the present mAs, the technique correction factor (CF) given in figure 9.2 ( $CF = 1/1.80 = 0.56$ ).

The relative contrast of these two films will be defined using the thickness,  $T_1$  and  $T_2$  of aluminum which

produced a density of 0.25 and 2.00 above the B+F level of the film (3.5).

The relative contrast is expressed by the following:

$$\text{Relative Contrast} = \frac{1.75}{T_1 - T_2}$$

For example, Film A required thickness of 1.54 =  $T_1$  and 0.86 =  $T_2$  or,

$$\text{Relative Contrast} = \frac{1.75}{1.54 - 0.86} = 2.57$$

For Film B we have

$$\text{Relative Contrast} = \frac{1.75}{1.41 - 0.54} = 2.01$$

This now provides two relative objective measures for the comparison of screen-film systems under the operating conditions of your department and gives you a method to assist in deciding which-screen-film combination will produce the best results with the lowest dose to the patient.

## 9.2. ACCEPTANCE TESTING OF RADIOGRAPHIC MATERIALS

Radiographic film can be damaged in shipment by excessive heat in storage areas. Radiation damage may occur if the film is inadvertently shipped with, or stored in the vicinity of radioactive materials. Chemistry can be damaged by freezing, excessive heat, or container leakage. Damaged materials should not be accepted by the department, and if some are inadvertently accepted, the manufacturer should be notified immediately with the specific information to indicate that the materials are faulty.

The simplest method for testing radiographic films is to expose a sheet of suspect film and a sheet of your control emulsion film with sensitometer or with the method described in chapter 9.1. These two films should be processed at the same time and fed into the processor in the same direction. In addition, the control emulsion should be the same type of film as the suspect film so that you have a direct comparison. Sheets from the suspect box of film should be selected from each side and from the center of the pack of the film.

If you expose the films with your sensitometer with the three patch sensitometric control strip, compare the B+F, MD (Mid Density) and DD (Density Difference) values

for the suspect film and the control emulsion. If the MD and DD values differ more than  $\pm 0.15$  from the control emulsion, the film has probably been damaged and the shipper and/or supplier should be notified immediately. Likewise, if the B+F of the suspect emulsion differs from the B+F of the control emulsion by more than 0.05, the film has probably been damaged. (5)

If you use the aluminum step wedge exposure technique to check your film, it will be necessary to plot the two thickness of Al. vs. density curves for the control emulsion and the suspect emulsion. Find the point on the curve of the control emulsion at a density of 1.0 above the B+F level. Moving vertically find the density of the suspect emulsion which corresponds to the thickness of aluminum which produced the 1.0 density (above fog) on the control emulsion. These two densities should agree with  $\pm 0.15$ .

To determine the density difference for the two films, locate the points on the curve of the control emulsion at densities of 0.25 and 2.0 above the B+F level of the film. Determine the thickness difference of aluminum between these two points. Find the density of 0.25 above fog on the suspect emulsion. Move to the right of the point horizontally a distance equal to the thickness difference determined for the control emulsion and determine the density for the suspect emulsion. Subtract the two densities of the suspect

emulsion. Subtract the two densities of the suspect emulsion to obtain the density difference. This value should be  $1.75 \pm 0.15$ .

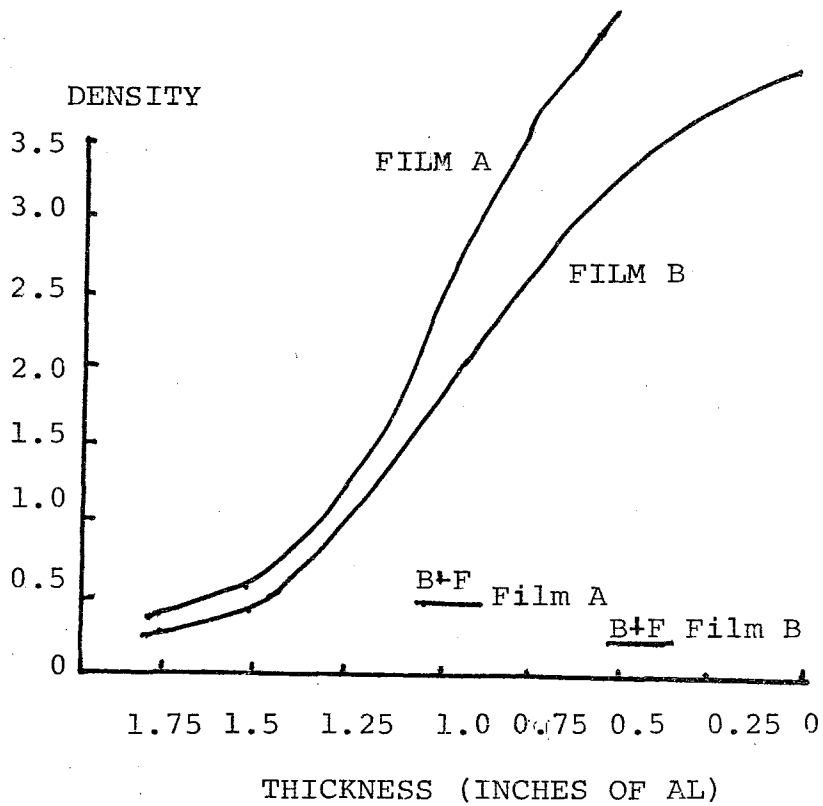

Figure 9.1 : Density vs. thickness of aluminum.

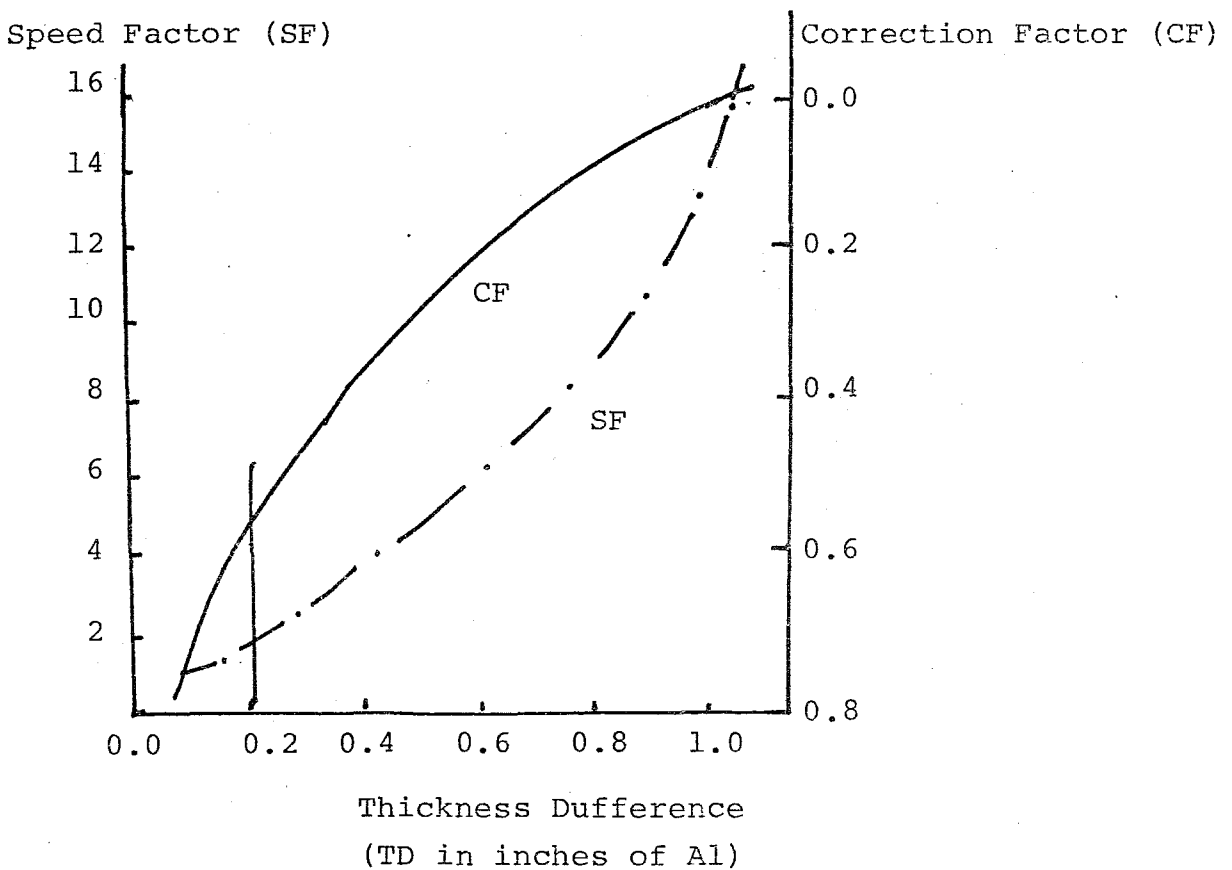

Figure 9.2 : Speed factor and correction factor as a function of thickness difference.

CHAPTER IX.REFERENCES

1. "Processing and Handling of Medical X-Ray Films" Pub. No XM3-3E, N.Y. Fuji Photographic Films, 1978.
2. Henry GC: "Artifacts In Roentgen Films" Radiol. 24, No. 3:350 - 356, 1935.
3. "Products For Medical Diagnostic Imaging", Pub. No. M5-15 Rochester, Eastmant Kodak, 1981.
4. "The Fundamentals of Radiography" Eastman Kodak Company, Rochester 4, N.Y. 10 th edition.
5. J.Gray, "The Basic Principles of Daily Photographic Quality Assurance", HEW Publications, FDA, 76 - 8043
6. R.J. Sweeney, "Radiographic Artifacts", J.B. Lippincott Company. Philadelphia.
7. WHO, "Quality Assurance In Diagnostic Radiology", Geneva 1982.

CHAPTER X.FILM PURCHASING POLICY IN TURKEY

All medical X-ray films including dental X-ray films, are purchased governmentally by KIZILAY in Turkey. Therefore, only one type of film can be sold in Turkey. There is no chance for the end-user to select the type of the film. Only special films (Computed Tomography, Mammography, RP-3, inch basis films, etc.) can be demanded to Kizilay by the radiologist by giving the amount and the brand name of the film.

In Turkey, double side emulsion films (13x18cm, 18x24cm, 24x30cm, 30x40cm. and 35x35cm) and dental films are purchased on an annual basis with great stocks by governmental tender. The films are stored ordinarily (not in frozen conditions). In the last three years AGFA - GEVAERT has gained the tender and this company is still maintaining the medical X-ray film supply (Curix RP-1) to Turkey.

Having one type of film in the country may have some advantages and disadvantages. One of the major disadvantage is that, finding special films is quite difficult in Turkey. In case special purpose films are ordered, delivery can take months. Another disadvantage is that the end-user has no

chance to compare the quality of different types of films and then select the best one for his purpose and working conditions. But, this disadvantage may seem as an advantage to others. Since technologists are not well trained in Turkey, the use of one type of film could be easier to handle.

Since there is no competition on film selling (at least for the period indicated by the contract), there is no adequate after sale service. That is, there is no help to the end -users about quality assurance procedures and how to properly use the film.

Since technologists are not well trained in Turkey. the use of one type of film can help the technologist in choosing the proper processing techniques. If more than one type of film were to be used, then the optimization of film processing conditions might be cumbersome and compromise film quality.

#### REFERENCES

1. Türkiye Kızılay Derneği Ankara/Turkey
2. Türkiye Atom Enerji Kurumu Ankara/Turkey
3. Istanbul University Medical Faculty, Radiology  
Department Istanbul/Turkey

CHAPTER XI.CONCLUSION:

In this thesis we have discussed photographic quality assurance procedures for improving diagnostic information through better usage of film technology.

We presented the importance of quality control in diagnostic radiology, nuclear medicine and radiation therapy. In order to assess the need for such programs we conducted a survey work and then performed a daily quality assurance programme in a private clinic for a period of one month.

The conclusions obtained from the surveyed 32 centers are as follows;

- 1- The manual processing techniques are fairly bad in Turkey due to improper training of technologists.
- 2- The large number of patients admitted to the department do not allow adequate time for processing.
- 3- Adequate techniques are not known by the technologists.
- 4- Proper chemicals are not used.
- 5- Chemicals in the developer and the fixer tanks are not replenished at all (in manual processing of X-ray films) and are usually being diluted by water. Therefore, the strength of chemicals decrease rapidly in a matter of

days.

- 6- The darkroom design is usually poor. Light leaks are not checked, proper safelights and filters are not used.
- 7- Films are not washed thoroughly. In fact, we have noted large number of stained films.
- 8- We did not encounter any water filter in any of the darkrooms that we have surveyed.
- 9- Not much effort is accorded into keeping the darkroom area clean, and of course no quality control procedures are used to keep the basic characteristic figures (B+F, contrast, speed, etc.) in tight limits.
- 10-Due to poor processing and darkroom techniques and lack of quality control procedures, the film quality has been found to be generally bad compared to the USA and European standards.

In addition to the lack of usefull diagnostic information due to improper processing techniques, the wide variations of processing characteristic figures indicate that high exposure doses are given in most cases. Furthermore, the lack of consistency in processing leads to improper errors in choosing the proper exposure techniques which in turn is another factor that leads to higher radiation dose to the patient and bad image quality (Please see Chapter 7).

The quality control program that we have implemented

(Chapter 6) has turned out to be very successful and convinced us that implementing quality control techniques can solve a good part of the image quality, radiation dose, and problems related to repeats.

By implementing quality assurance procedures, we decreased the radiation dose 25-35%. Repeat rate decreased from 12% to 6%. 15% economy has resulted in cost due to decrease in repeat rate and economy from films and chemicals. During our quality assurance programme throughout a month we have noted the approximate figures as follows;

<u>Expenditures due to:</u>	<u>Before QA</u>	<u>After QA</u>
Chemicals	35,000.-TL.	23,000.-TL.
Films	265,000.-tl.	232,000.-TL.
TOTALLY	300,000.-TL.	255,000.-TL.

Therefore in this private clinic 540,000.-TL. can be saved over 3,600,000.-TL. annually.

If we assume the same amount of economy in our surveyed 32 centers, the result will be 17,280,000.-TL. over 155,200,000.-TL. Keep in mind that this economy has resulted due to decrease in repeat rate and economy from films and chemicals. Economy due to decrease in radiation dose, thus increasing tube life, was not considered in these calculations.

On the other hand, there are obviously more than 32 centers in the Istanbul Area. Furthermore, the working conditions are worse and expenditures (due to repeat rate, Wasted films and chemicals, light fog in the darkroom therefore more  $kV_p$  and more mAs to the patient) grow numerous in the countryside. By applying quality assurance procedures millions of Turkish Liras can be saved without paying much effort. (Only 10 minutes to establish the operating levels of the processors in the mornings.)

In this thesis, we also have studied how films are purchased and stored. There seems to be some aspects of the purchasing procedure which could be changed into making it more scientific. Since Turkey uses only one manufacturer's film, she experiences several advantages and disadvantages. The disadvantages could be that; special films for special needs may be difficult to obtain. On the other hand, the advantages are numerous; since the technologists are not well trained in Turkey, the use of one manufacturer's film could be easier to handle. Second, film purchasing is made easier and cheaper for most hospitals particularly for the ones in remote areas. This purchasing policy can help the technologist in choosing the proper processing techniques. If more than one manufacturer's film were to be used, then the optimization of the film chemicals would be cumbersome due to improper

training of technologists in Turkey. Therefore, only those hospitals who have access to qualified technical help can benefit from using more types of film.

It is therefore essential that training programmes for the introduction and wide application of quality assurance procedures in diagnostic radiology should be established for the various categories of personnel in need of such training.

However, the groups of people concerned should be encouraged to make the maximum use of elements relating to quality assurance in their basic professional training, and such professional training should, in future, incorporate the basic concepts inherent in quality assurance programmes.

In view of the variety of backgrounds and responsibilities of the categories of personnel to be trained in quality assurance procedures, training should be provided for the following groups:

- 1- radiographers or medical radiology technicians, who have to perform on a routine basis the techniques recommended throughout this thesis,
- 2- radiologists who are the user of diagnostic image must be aware of all essential factors that influence the image quality and patient exposure and induce artifacts etc. They have to know the quality assurance procedures

in principle,

3- medical and health physicists, X-ray engineers, and Biomedical engineers. This group would need the most complex training, producing specialist in quality assurance procedures who are able to carry out a wide range of techniques, assess performance of imaging systems, and (where appropriate) repair the faulty parts of the equipment. It will be necessary for these specialists to collaborate with all the other categories of staff specified above, in order that they may play a major role in the training of all personnel in quality assurance procedures.

It is desirable that basic-level training of medical radiology technicians and other persons involved in quality assurance procedures should be organized nationally.

The training of medical and health physicists, X-ray engineers, Biomedical engineers, and engineering technicians could be conducted in which adequate technical knowledge and suitable facilities exist. In the absence of these resources, such training would have to be organized on an international basis.

Overall, we can say that, there is concrete evidence which shows that image quality in Turkish hospitals could be improved and brought to an acceptable diagnostic level by

starting to use proper processing and darkroom techniques and implementing quality control procedures in every center.

In the short-term;

- 1-Initiating quality assurance programmes in a pilot area and the pilot hospitals,
- 2-Establishing training courses about quality assurance programmes,
- 3-Implementing the results,
- 4-Establishment of a quality assurance committee and arranging regular meetings,
- 5-Getting favor of Biomedical engineers in preparing technical specifications of an equipment in the tenders and in the acceptance tests of these equipments,
- 6-Encouraging quality assurance programmes.

These procedures should be continued in the long-term basis. Also;

- 1-Standards, recommendations and regulations should be established, and
- 2-Quality assurance procedures should be spread out all around the country.

But, keep in mind that the solutions specified in the long-term basis could be started after implementing short-term solutions for few years.