

BEHAVIOUR OF HIGH-RISE STEEL BUILDINGS UNDER LATERAL LOADS
EFFECTS

by

Emir Gamari

B.S., Civil Engineering, Istanbul University, 2009

Submitted to the Institute for Graduate Studies in
Science and Engineering in partial fulfillment of
the requirements for the degree of
Master of Science

Graduate Program in Civil Engineering
Boğaziçi University
2015

ACKNOWLEDGEMENTS

I want to present my deepest appreciation to my thesis supervisor Prof. Gülay Altay. She did not only guide me throughout this study, but also she encouraged me to study more focused and motivated. She created time for the study even in her busy times.

I m very grateful to the members of my thesis' examining committee checked my study and shared their valuable comments with me.

I want to present my last thanks to my family who always believed in my abilities and made me believe that I can achieve anything.

ABSTRACT

BEHAVIOUR OF HIGH-RISE STEEL BUILDINGS UNDER LATERAL LOADS EFFECTS

Design of high rise buildings is generally predicated on lateral forces like wind loads and earthquake loads. However high rise buildings are mostly reactive to dynamic oscillations due to wind loads because of having materials which are low in damping and lighter in weight. In this thesis, wind effects on high rise steel buildings designed with various outriggers and belt truss systems are examined and comparisons of results are presented. The buildings are analyzed according to the load specifications of American Society of Civil Engineers, Minimum Design Loads for Buildings and Other Structures 2010 and Turkish Earthquake Code 2007. The results and responses of buildings in both wind and earthquake loads are compared by taking account of these specification provisions. It is seen that lateral stiffness demand for the wind is more severe than earthquake along the long direction of buildings. Design wind speed is obtained from the results of a study including region-specific statistical analysis of wind data in Turkey. Wind load calculations and application procedures are given. Another important part of this study is to explain behavior of outrigger and belt truss systems on high rise buildings under wind loads. The location of the outrigger and belt truss systems has an immense influence on the efficiency of the structure. A three dimensional finite element analysis is performed with one, two and three outrigger levels. By changing the number and locations of outriggers on two buildings having different heights, structural analyses are carried out with SAP2000. The results are compared to demonstrate positive effects of outrigger and belt truss systems on lateral stiffness of buildings. Moreover, for giving a better understanding of the efficiency of outrigger when different structural outriggers are used in the buildings, three different structural outrigger systems are analyzed by using SAP2000 program and results are compared. All results, comparisons and calculations are given in this paper.

ÖZET

YANAL YÜK ETKİSİ ALTINDA YÜKSEK KATLI ÇELİK BİNALARIN DAVRANIŞI

Çok katlı yüksek binalar genellikle yatak yükler olan rüzgar ve deprem yükleri dikkate alınarak dizayn edilir. Genellikle yüksek katlı binalar düşük ağırlıklı, sönük malzemelere sahip olduğundan dolayı rüzgar yüklerinin neden olduğu dinamik titreşimlere karşı hassastır. Bu çalışmada, çeşitli outrigger kemer makas sisteminin kullanıldığı çok katlı çelik binalar yanal yükler altında incelenmiştir ve çıkan sonuçların karşılaştırması sunulmuştur. Bina American Society of Civil Engineers teknik şartnamesindeki esaslara ve Türk Deprem Yönetmeliği 2007 şartnamesindeki esaslara göre analiz edilmiştir. Bu şartnamedeki esaslar göz önüne alınarak rüzgar ve deprem kuvveti altında binaların verdiği sonuçlar karşılaştırılmıştır. Binaların uzun doğrultusu boyunca rüzgara karşı istenen yatay rijitliğin depreme karşı istenenden daha fazla olduğu görülmüştür. Dizayn rüzgar hızı değeri Türkiye'deki bölgesel rüzgar verilerinin istatistiksel analizinin yapıldığı bir çalışmanın sonuçlarından elde edilmiştir. Rüzgar yüklerinin hesaplama ve uygulama yöntemleri verilmiştir. Bu çalışmanın bir diğer önemli kısmı rüzgar kuvveti altında outrigger kemer makas sistemine sahip binaların davranışlarını açıklamaktır. Outrigger kemer makas sistemlerinin yapının etkinliğinde muazzam bir etkisi vardır. 3 boyutlu sonlu elemanlar analizi birli, ikili ve üçlü outrigger seviyeli halleriyle uygulanmıştır. Binalar üzerindeki outrigger kemer makas sistemlerinin sayısı ve yerleri değiştirilerek SAP2000 programı ile analizler yapılmıştır. Analiz sonuçları yapıların yatay rijitliğine outrigger kemer makas sistemin pozitif etkilerini göstermek için karşılaştırılmıştır. Dahası, binalarda farklı yapısal outrigger sistemlerinin kullanıldığı zamanki outrigger sistemlerinin etkinliğini daha iyi anlamak için, SAP2000 programı kullanılarak üç farklı yapıdaki outrigger sistemler analiz edilmiş ve sonuçlar karşılaştırılmıştır. Tüm hesaplamalar, karşılaştırmalar ve sonuçlar bu çalışmada verilmiştir.

TABLE OF CONTENTS

ACKNOWLEDGEMENTS	iii
ABSTRACT.....	iiiv
ÖZET	v
LIST OF FIGURES	x
LIS OF TABLES	xv
LIST OF SYMBOLS	xvii
LIST OF ACRONYMS/ABBREVIATIONS	xix
1. INTRODUCTION	1
1.1. Introduction	1
1.2. Structural Systems of High-Rise Buildings.....	2
1.3. Classification of High-Rise Building Structural Systems	7
1.4. Different Floor Plans of High-Rise Building	9
1.5. Examples in Practice Related with the Design of High-Rise Buildings	11
2. OUTRIGGER STRUCTURAL SYSTEM	16
2.1. Background of Outrigger Structural System	17
2.2. Benefits and Challenges of Outriggers	18
2.2.1. Benefits of Outriggers	18
2.2.2. Disadvantages and Challenges of Outriggers	19
2.3. Favorable Conditions for Outriggers	20
2.4. Load Transfer Path in Outrigger System	21
2.5. Determining Locations and Numbers of Outriggers	22
2.6. Examples of Outriggers in Practices	23
2.6.1. The First Wisconsin Center.....	23

2.6.2.	One Houston Center.....	24
2.6.3.	Place Victoria.....	25
3.	WIND LOADS ON HIGH-RISE BUILDINGS.....	26
3.1.	Wind Velocity Variation with the Height	29
3.1.1.	The Atmospheric Boundary Layer.....	29
3.1.2.	The Logarithmic Law.....	30
3.1.3.	The Power Law	31
3.1.4.	Relation between Wind Speeds in Different Roughness Regimes	32
3.1.5.	Atmospheric Turbulence.....	33
3.2.	Drag, Lift and Pressure Coefficients in Wind Flow	33
4.	SEISMIC DESIGN CRITERIA OF HIGH-RISE BUILDINGS.....	35
4.1.	Introduction and Background	35
4.2.	Design Objectives and Philosophy.....	36
4.2.1.	Deformation Based Design Philosophy	37
4.3.	Seismic Structural Analysis and Modeling	38
4.4.	Elastic Analysis	40
4.5.	Non-linear Response History Analysis	41
5.	DESIGN PROVISIONS	42
5.1.	General Design Provisions	42
5.1.1.	Wind Loads	43
5.1.2.	Other Loads.....	45
5.1.2.1.	Dead Loads	45
5.1.2.2.	Live Loads.....	46
5.1.2.3.	Earthquake Loads.....	47
5.1.2.4.	Structural Analysis and Procedures of Earthquake Loads	48
5.1.2.5.	Structural Irregularities	49

5.1.3.	Load Combinations	51
6.	DESCRIPTION OF THE STRUCTURAL SYSTEM OF ANALYZED BUILDINGS	53
7.	LOADS ACTING ON THE BUILDING	60
7.1.	Dead and Live Loads	60
7.1.1.	Distribution of Dead and Live Loads.....	60
7.2.	Wind Loads	62
7.3.	Earthquake Loads	73
8.	COMPARISON OF ANALYSIS RESULT OF WIND AND EARTQUAKE LOADINGS ON BUILDINGS.....	80
9.	DESIGN SECTIONS OF MEMBERS.....	89
10.	CASE STUDIES	92
10.1.	Case Study 1: 40-Story Building.....	92
10.1.1.	Determination of Optimum Location of Single Outrigger System on 40-Story Building.....	94
10.1.2.	Determination of Optimum Location of Two Outrigger Systems on 40-Story Building.....	95
10.1.3.	Determination of Optimum Location of Three Outrigger Systems on 40-Story Building.....	97
10.1.4.	Comparison of Various Outrigger Systems on 40-Story Building	99
10.1.5.	Comparison of Different Types of Outrigger Systems on 40-Story Building.....	101
10.2.	Case Study 2: 60-Story Building.....	105
10.2.1.	Determination of Optimum Location of Single Outrigger System on 60-Story Building.....	106
10.2.2.	Determination of Optimum Location of Two Outrigger Systems on 60-Story Building.....	107

10.2.3.	Determination of Optimum Location of Three Outrigger Systems on 60-Story Building.....	109
10.2.4.	Comparison of Various Outrigger Systems on 60-Story Building	111
10.2.5.	Comparison of Different Types of Outrigger Systems on 60-Story Building.....	113
10.	CONCLUSIONS	116
	REFERENCES	119

LIST OF FIGURES

Figure 1.1.	Structural systems comparison (CTBUH, 1995).....	8
Figure 1.2.	Steel, reinforced concrete and composite companions to Khan’s structural system hierarchy (Sarkisian, 2011).....	9
Figure 1.3.	Geometry of different floor plans of high-rise buildings (Paul H K Ho, 2007).....	10
Figure 1.4.	Petronas Tower foundation profile (Joseph, 1997).....	12
Figure 1.5.	Taipei 101 schematic view (Shieh, 2003).....	13
Figure 1.6.	Floor plan of Taipei 101 (Chang <i>et al.</i> , 2003).....	14
Figure 1.7.	Floor plan of Shanghai World Financial Centre (Katz, 2008).....	15
Figure 2.1.	Schematic 3D view of outrigger and belt truss system (Smith <i>et al.</i> , 1996).....	16
Figure 2.2.	Floor layout of outrigger and belt truss system (Fawzia, 2010).....	17
Figure 2.3.	Interaction of core and outriggers (Taranath, 1998).....	18
Figure 2.4.	Outrigger at core (Nair, 1998).....	18
Figure 2.5.	Transfer of gravity loads from column to core (Tomasetti, 2001).....	22
Figure 2.6.	Effect of outrigger system location (Tomasetti, 2001).....	23
Figure 2.7.	First Wisconsin Center, Milwaukee, USA (Taranath, 1998).....	24

Figure 2.8.	One Houston Center, USA (Taranath, 1998).....	24
Figure 2.9.	Place Victoria in Montreal, Canada (CTBUH, 1995).....	25
Figure 3.1.	Mean wind profile as measured in a rotating wind tunnel (Simiu and Scanlan, 1986).....	30
Figure 3.2.	Wind velocity profiles in different roughness regimes (Simiu and Scanlan, 1986).....	32
Figure 4.1.	Deformation parameters for high-rise buildings (CTBUH, 2005).....	38
Figure 6.1.	3D View of sixty-floor building model without belt-trussed frame system.....	54
Figure 6.2.	3D view of sixty-floor building model with belt-trussed frame system.....	55
Figure 6.3.	Typical floor plan of the building.....	56
Figure 6.4.	1 and 4 axis view of sixty-floor building without belt-trussed frame system.....	56
Figure 6.5.	2 and 3 axis view of sixty-floor building without belt-trussed frame system.....	57
Figure 6.6.	3D view of single story.....	57
Figure 6.7.	3D view of conventional outrigger and belt truss.....	58
Figure 6.8.	3D view of deep outrigger and belt truss.....	58
Figure 6.9.	3D view of inverted v outrigger and belt truss.....	58
Figure 7.1.	Tributary areas of interior and exterior beams.....	60
Figure 7.2.	Given specific codes of beams.....	61

Figure 7.3.	Full wind loads in two perpendicular directions considered separately.....	65
Figure 7.4.	75% wind loads in two perpendicular directions with 15% eccentricity considered separately.....	66
Figure 7.5.	75% wind loads in two perpendicular directions simultaneously.....	66
Figure 7.6.	56.3% of wind load in two perpendicular directions with 15% eccentricity simultaneously.....	66
Figure 7.7.	Elastic acceleration spectrum curve.....	76
Figure 8.1.	The comparison of shear forces at the base of 60-story and 40-story buildings in y-direction.....	82
Figure 8.2.	The comparison of moment values at the base moments of 60-story and 40-story buildings in y-direction.....	82
Figure 8.3.	Shear forces at each floor of 40-story building in y-direction.....	83
Figure 8.4.	Shear forces at each floor of 60-story building in y-direction.....	84
Figure 8.5.	Overturning moment values at each floor of 40-story building in y-direction	84
Figure 8.6.	Overturning moment values at each floor of 60-story building in y-direction	85
Figure 9.1.	Group number of column groups on floor plan.....	89
Figure 9.2.	Design sections of beams of floor plan.....	90
Figure 9.3.	X-Y plane view of beam elements with d/c ratio.....	91
Figure 9.4.	X-Z view of 60-story building with d/c ratio.....	91
Figure 10.1.	Diagrammatic representation of wind loads on 40-story building.....	92

Figure 10.2.	Optimum location of single outrigger system on 40-story building.....	94
Figure 10.3.	Graph of top deflection and number of story for optimum location of single outrigger system on 40-story building.....	95
Figure 10.4.	Optimum location of two outrigger systems on 40-story building.....	96
Figure 10.5.	Graph of top deflection and number of story for optimum location of two outrigger systems on 40-story building.....	96
Figure 10.6.	Graph of top deflection and arrangements for optimum location of three outrigger systems on 40-story building.	98
Figure 10.7.	Optimum location of three outrigger systems on 40-story building.....	98
Figure 10.8.	Comparison of various outrigger options of 40-story building.....	99
Figure 10.9.	Story drift comparison of various outrigger options of 40-story building.	100
Figure 10.10.	Different types of outrigger and belt truss systems on 40-story building.....	102
Figure 10.11.	Section cuts of different types of outrigger and belt truss systems.....	103
Figure 10.12.	Graph of deflection different types of outrigger and belt truss systems on 40-story building.....	103
Figure 10.13.	Diagrammatic representation of wind loads on 60-story building.....	105
Figure 10.14.	Optimum location of single outrigger system on 60-story building.....	106
Figure 10.15.	Graph of top deflection and number of story for optimum location of single outrigger system on 60-story building.....	107
Figure 10.16.	Optimum location of two outrigger systems on 60-story building.....	108

Figure 10.17. Graph of top deflection and number of story for optimum location of two outrigger systems on 60-story building.....	108
Figure 10.18. Graph of top deflection and arrangements for optimum location of three outrigger systems on 60-story building.....	110
Figure 10.19. Optimum location of three outrigger systems on 60-story building.....	110
Figure 10.20. Comparison of various outrigger options of 60-story building.....	111
Figure 10.21. Story drift comparison of various outrigger options of 60-story building.	112
Figure 10.22. Different types of outrigger and belt truss systems on 60-story building..	114
Figure 10.23. Comparison of different types of outrigger systems on 60-story building.....	115

LIST OF TABLES

Table 1.1.	Structural systems of high-rise buildings (Schueller, 1977, Gustafsson <i>et al.</i> , 2005).....	2
Table 3.1.	Values of δ and α	31
Table 5.1.	Risk category of buildings and other structures for flood, wind, snow, earthquake, and ice loads (ASCE7-10).....	42
Table 5.2.	Live load element factor, K_{ll} (ASCE7-10).....	47
Table 6.1.	Model structural configurations.....	53
Table 7.1.	Distributed loads on beams and load distribution style.....	62
Table 7.2.	50-year return period design wind speed for Istanbul (Tek <i>et al.</i> , 1993).....	63
Table 7.3.	100-year return period design wind speed for Istanbul (Tek <i>et al.</i> , 1993)....	63
Table 7.4.	Parameters of exposure B, C and D (ASCE7-10).....	64
Table 7.5.	Wind loads in x-direction.....	67
Table 7.6.	Distributed windward loads in x-direction.....	69
Table 7.7.	Distributed leeward loads in x-direction.....	70
Table 7.8.	Wind loads in y-direction.....	70
Table 7.9.	Distributed windward loads in y-direction.....	72
Table 7.10.	Distributed leeward loads in y-direction.....	73

Table 7.11.	Soil groups (TEC-2007).....	74
Table 7.12.	Local site classes (TEC-2007).....	74
Table 7.13.	Spectrum characteristic periods.....	75
Table 8.1.	Share force and moment at the base of 60-story building due to wind and earthquake in x-direction.....	80
Table 8.2.	Share force and moment at the base of 60-story building due to wind and earthquake in y-direction.....	80
Table 8.3.	Share force and moment at the base of 40-story building due to wind and earthquake in x-direction.....	80
Table 8.4.	Share force and moment at the base of 40-story building due to wind and earthquake in y-direction.....	81
Table 8.5.	Base shears and overturning moment of 60-story building in y-direction...	85
Table 8.6.	Base shears and overturning moment of 40-story building in y-direction..	86
Table 9.1.	Design sections of column groups of 60-story building.....	89
Table 9.2.	Design sections of column groups of 40-story building.....	90
Table 10.1.	Various arrangements for three outrigger system options of 40-story building.....	97
Table 10.2.	Maximum displacement and percentage reduction in deflection for each option of 40-story building.....	100
Table 10.3.	Maximum story drift and percentage reduction in story drift for each option of 40-story building.....	101

Table 10.4.	Displacement comparison of three types of outrigger systems of 40-story building.....	104
Table 10.5.	Various arrangements for three outrigger system options of 60-story building.....	109
Table 10.6.	Maximum displacement and percentage reduction in deflection for each option of 60-story building.....	112
Table 10.7.	Maximum story drift and percentage reduction in story drift for each option of 60-story building.....	113
Table 10.8.	Displacement comparison of three types of outrigger systems of 60-story building.....	116

LIST OF SYMBOLS

A_o	Effective ground acceleration coefficient
A_T	Tributary area of the member
$A(T)$	Spectral acceleration coefficient
B_B	Reference dimension of the body perpendicular to the flow direction
C_D	Non-dimensional drag coefficient
C_L	Non-dimensional lift coefficient
C_P	Non-dimensional pressure coefficient
F_D	Net wind-pressure force in the drag direction
F_L	Net wind-pressure force in the lift direction
F_{wind}	Wind force of the story
G	Gradient wind speed at the top of the boundary layer height
g	Acceleration of gravity
H_B	Reference dimension of the body perpendicular to the flow direction
I	Building importance factor
k	Karman's constant
K_{LL}	Live load element factor
K_z	Wind velocity exposure pressure coefficient evaluated at height z

L	Reduced design live load per square meter of area supported by the member
L_o	Unreduced design live load per square meter of area supported by the member
M_x	Overturning moment at base in x direction
M_y	Overturning moment at base in y direction
p	Local pressure
P	Wind pressure on unit area
P_L	Wind pressure acting on leeward face
P_{LR}	Leeward wind pressure acting on the column located on the right side of tributary area
P_{LL}	Leeward wind pressure acting on the column located on the left side of tributary area
P_W	Wind pressure acting on windward face
P_{WR}	Windward wind pressure acting on the column located on the right side of tributary area
P_{WL}	Windward wind pressure acting on the column located on the left side of tributary area
R	Structural behavior factor
R_a	Seismic load reduction factor
q_z	Wind velocity pressure evaluated at height z
$S(T)$	Spectrum coefficient
$S_{ae}(T)$	Elasticity spectrum ordinate [m /s ²]

T	Building natural vibration period
T_A, T_B	Spectrum characteristic periods
u^*	Shear velocity above the surface
U	Mean wind velocity
$U(z)$	Mean wind speed at height z above the ground
V_x	Shear force in x direction
V_y	Shear force in y direction
z, z_g, z_{g1}, z_{g2}	Height above ground
z_0, z_{01}	Roughness length
z_l	Height of validity of the logarithmic law
α	Power law exponent depending on the roughness length
ρ_{air}	Mass of the air in unit volume
δ	Boundary layer height
δ	Design story drift
Δ	Displacement

LIST OF ACRONYMS/ABBREVIATIONS

ASCE	American Society of Civil Engineers
LRFD	Load and Resistance Factor Design
TEC	Turkish Earthquake Code

1. INTRODUCTION

1.1. Introduction

There is a close relation between the human population in large cities and high-rise buildings. Demand for high-rise buildings increases with the development of the cities with growth of population. The main problem in enormous cities is to place maximum number of people on a minimum area of land. These big buildings have some extra facilities, such as shopping mall, entertainment, health, security, education, transportation, parking areas, utilities, waste and sewage services that are equivalent to service of small cities. In order to design such large-scale buildings, many important arrangements of social, economical and ecological life are required to be done attentively.

Technological developments in the production of high-strength construction materials enabled designers to decrease the dead load, to increase leasable area and to make higher buildings with saving significant amount of money. Increased building heights decrease the land costs of per square meter of floor area apparently. Following this change reduces management costs because the management of one high-rise building costs less than managing many small buildings.

The performance of a high-rise building is based on the endurance of the soil on which it is founded. The superstructures connect to the soil with foundation. Foundations transfer loads coming from building to the soil so that the soil is capable of carrying loads. The selection of the building structure is strongly associated with the site's soil conditions. Before the decision on the structural system of high-rise building, the soil conditions must be investigated deeply. Thanks to this investigation soil behavior can be predicted. If the bearing capacity of the soil is low, by implementing piles, jet grounding or any required technique, the bearing capacity may be reached the adequate capacity. Alternative structural systems can be chosen for various soil conditions and foundation types.

Examples of different kinds of structural systems are given Table 1.1 (Schueller, 1977, Gustafsson *et al.*, 2005).

1.2. Structural Systems of High-Rise Buildings

Table 1.1. Structural systems of high-rise buildings (Schueller, 1977, Gustafsson *et al.*, 2005).

Parallel Bearing Walls System	Cores and Facade Bearing Walls System	Self-Supporting Boxes System
<p>Prestressed vertical elements by their weight constitute this system. These vertical elements are efficient to absorb lateral forces. Parallel bearing wall system is used for buildings in which large spaces are not necessary and mechanical systems of building don't need a core structure.</p> 	<p>In this system vertical elements are formed as outer walls around a core structure. The bearing capacity of the floor structure allows having large interior spaces in building. Elevator and mechanical systems are located in the core. Moreover the core increases the stiffness of the building.</p> 	<p>The assembly procedure of this system is similar to bearing wall system. The prefabricated boxes are three dimensional units. These boxes are put together like bricks and results in a criss-crossed pattern which gives itself stability. The problem of this system is the lack of a logical clarity and regularity.</p> 

Table 1.1. Structural systems of high-rise buildings (Schueller, 1977, Gustafsson *et al.*, 2005) (Continued)

Cantilever Slab System	Staggered Truss System	Rigid Frame System
<p>According to the slab that the size of the building is decided. This system creates enormous area without any column. The central core and the strength of slab support these areas. A large amount of steel is needed for this system and also by prestressing techniques the slab stiffness can be increased.</p>	<p>In this system story-high trusses are arranged such that each floor is resting on the top chord and partly on the bottom of the next one. In order to transfer the wind loads from the structure to the ground, the truss minimizes wind bracing requirements. Also these trusses carry the vertical loads.</p>	<p>Rigid frame system is formed in both directions of buildings. In order to manufacture this system, rigid joints are used between assemblages of linear elements. Both of the planes are arranged with the same way by using columns and beams as a rectangular grid. This system is favorable for mid-height buildings.</p>
		

Table 1.1. Structural systems of high-rise buildings (Schueller, 1977, Gustafsson *et al.*, 2005) (Continued)

Rigid frame and core System	Trussed Frame System	Flat Slab System
<p>The lateral stiffness of building increases substantially by adding a core to rigid frame system. In rigid frame system frames react to lateral loads by bending column and beams. Thanks to adding core bending moment effects are carried by core. For approximately 25-story buildings, this system is more effective.</p>	<p>Combining a rigid frame with vertical shear trusses increases the stiffness and strength of building. Trussed frame system is similar to rigid frame and core. In both systems, the frames are used for gravity loads and the vertical trusses are used for wind loads. In general this system is mostly used for 100-story buildings approximately.</p>	<p>Flat slab system was developed at the beginning of the century. Flat slab system is a horizontal storey-high system which comprises uniformly thick concrete slabs. These slabs are supported by columns.</p>
		

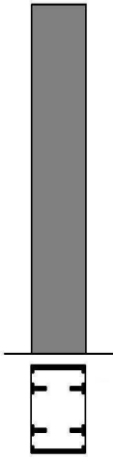
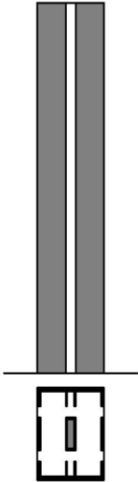
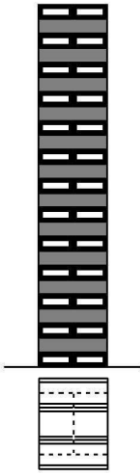
Table 1.1. Structural systems of high-rise buildings (Schueller, 1977, Gustafsson *et al.*, 2005) (Continued)

Interspatial System	Suspended System	Belt-Trussed Frame and Core System
<p>The cantilevered frames are used along the height of each floor. By taking in consideration to create useful space between and over the frames, the construction procedure is decided. Fixed operations are made in the space within the frame. Any kind of activity can be applied in the space above the frame.</p>	<p>In this system, instead of columns the floor loads are carried by hangers. This system offers efficient usage of material. A member which is subjected to compression has to have the strength decreased due to buckling while a member that is exposed for tension can use its full capacity.</p>	<p>The outer columns and the core are bound together by the belt trusses. By bonding together the trusses and the core, the individual action of frame and core is eliminated. This system is mostly utilized for approximately 60-story buildings.</p>
		

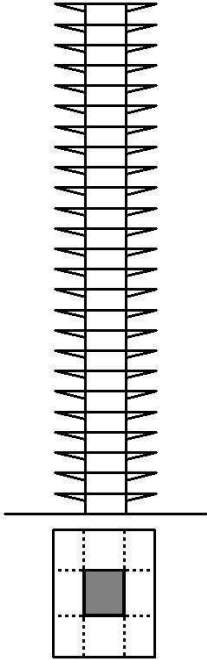
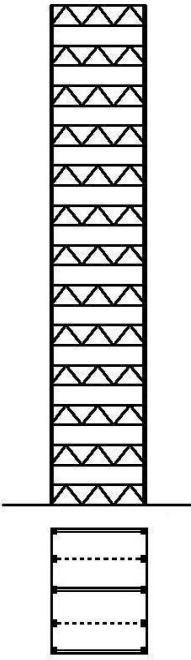
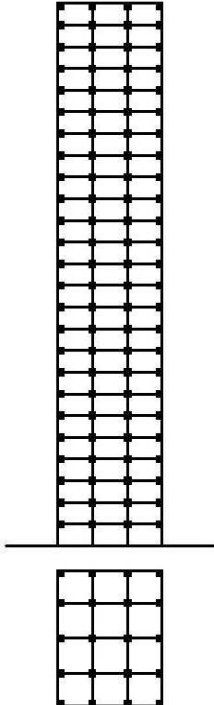
Table 1.1. Structural systems of high-rise buildings (Schueller, 1977, Gustafsson *et al.*, 2005) (Continued)

Tube in Tube System	Bundled Tube System
<p>In this system the facade of the system resembles a wall with cancellated window openings. The columns and beams are spaced very closely and this results cancellated window view. Because of this view the system is named the tube. The whole building looks like a hollow tube that cantilever from the ground. The interior tube increases the stiffness by sharing the loads with the exterior tube.</p>	<p>Many tubes of this system results in a multiple-cell tube and the increase in stiffness is obvious. This system allows best height and the largest floor area for building. This system is mostly used for 100 or more than 100-story buildings.</p>
	

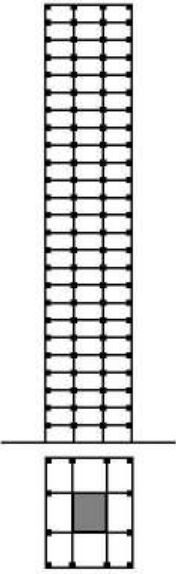
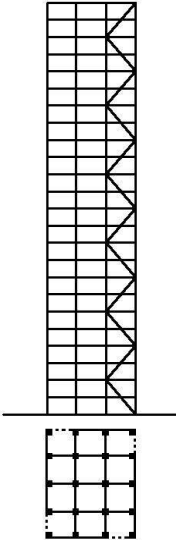
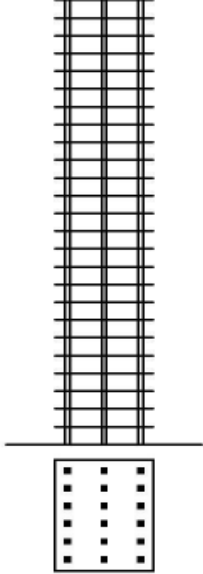
1.3. Classification of High-Rise Building Structural Systems

After all structural system definitions of high rise buildings, these structural systems can be classified into four basic groups; rigid and semi-rigid frames, shear wall or braced frames structures, shear wall or truss-frame interactive structures, and tube structures. Further than these basic groups tube structures can be categorized into frames tube systems and high efficiency tube systems. Figure 1.1 shows a comparison of high rise building systems versus number of stories. Thanks to this figure, it can be determined which system is more efficient for design, according to number of story of analyzed building in this study.

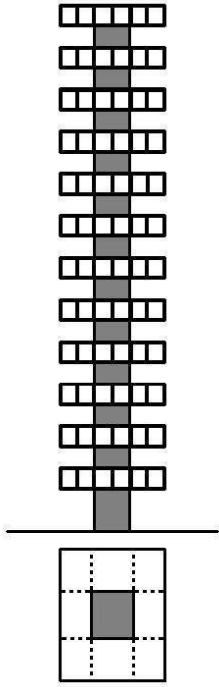
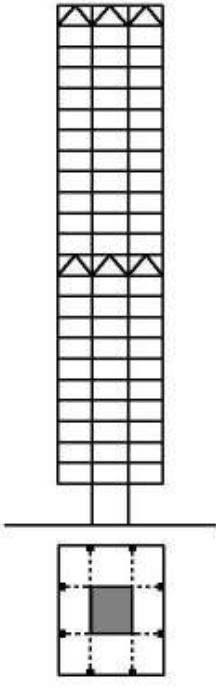
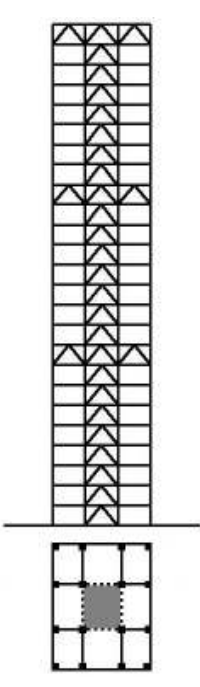
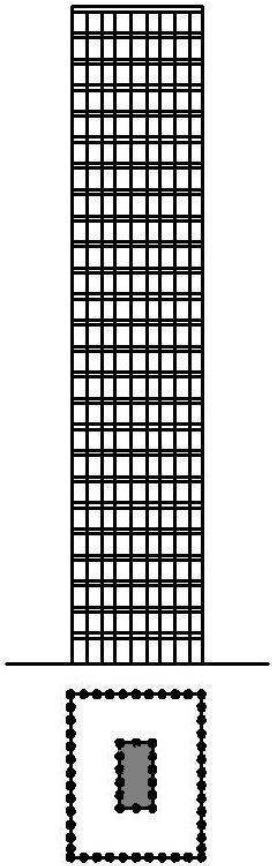
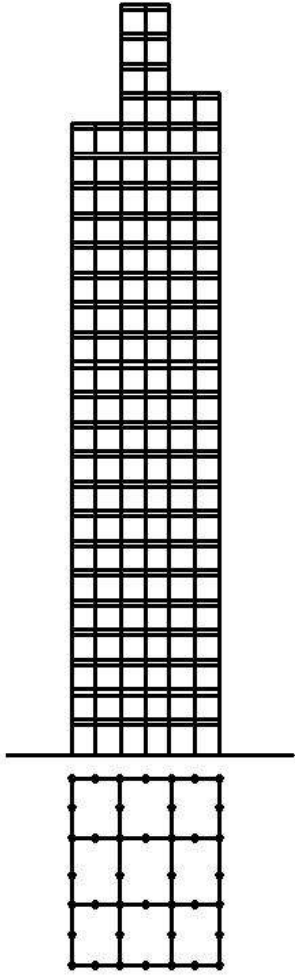
This structural comparison figure was created by Khan who is regarded as the father of skyscrapers. Thanks to Khan's innovations in both system conceptualization as and modeling, this new landscape in structural systems was created. This unique and innovative vision produced what is perhaps one of the most referenced conceptual design aids for high-rise building systems. The comparison figure represented a spectrum of steel high-rise building systems from shear frame system to tubular systems. For each system class, Khan indicated a number of stories. These numbers indication is based upon his experience (CTBUH, 1995).

After many years, designers have changed and expanded this table, by adding and creating companion charts for concrete and composite structures (McNamara, 2005; Sarkisian, 2011; Taranath, 2012; Zils and Viise, 2003). In every new chart, designers remained married to number of stories for the chart's parameterization. Figure 1.2 shows these expanded charts. Modern time designers utilized the Khan's comparison table and its successors for decades. Moreover this chart was utilized as an important educational tool to train young designers in the philosophy of system design.

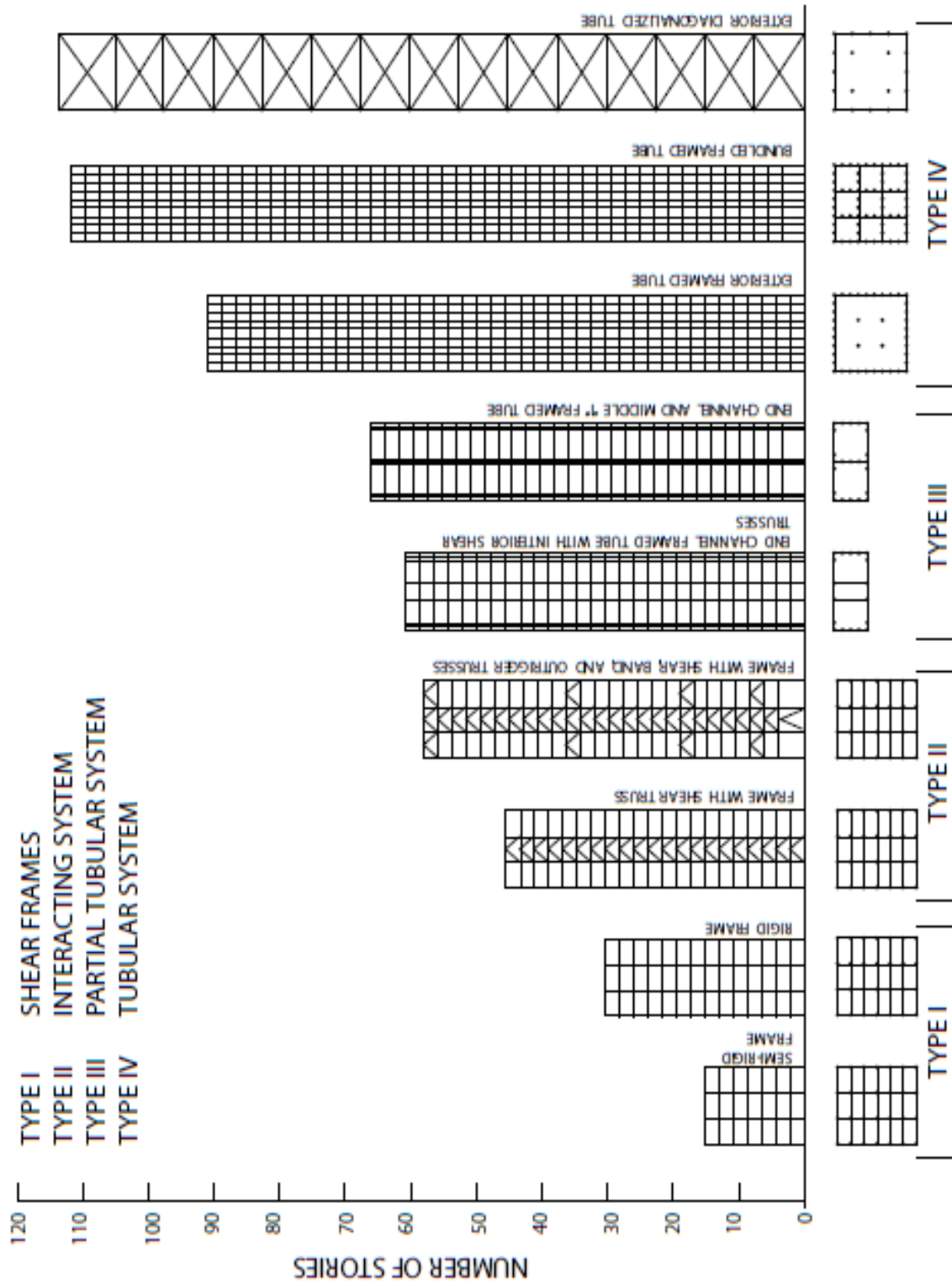

Figure 1.1. Structural systems comparison (CTBUH, 1995).

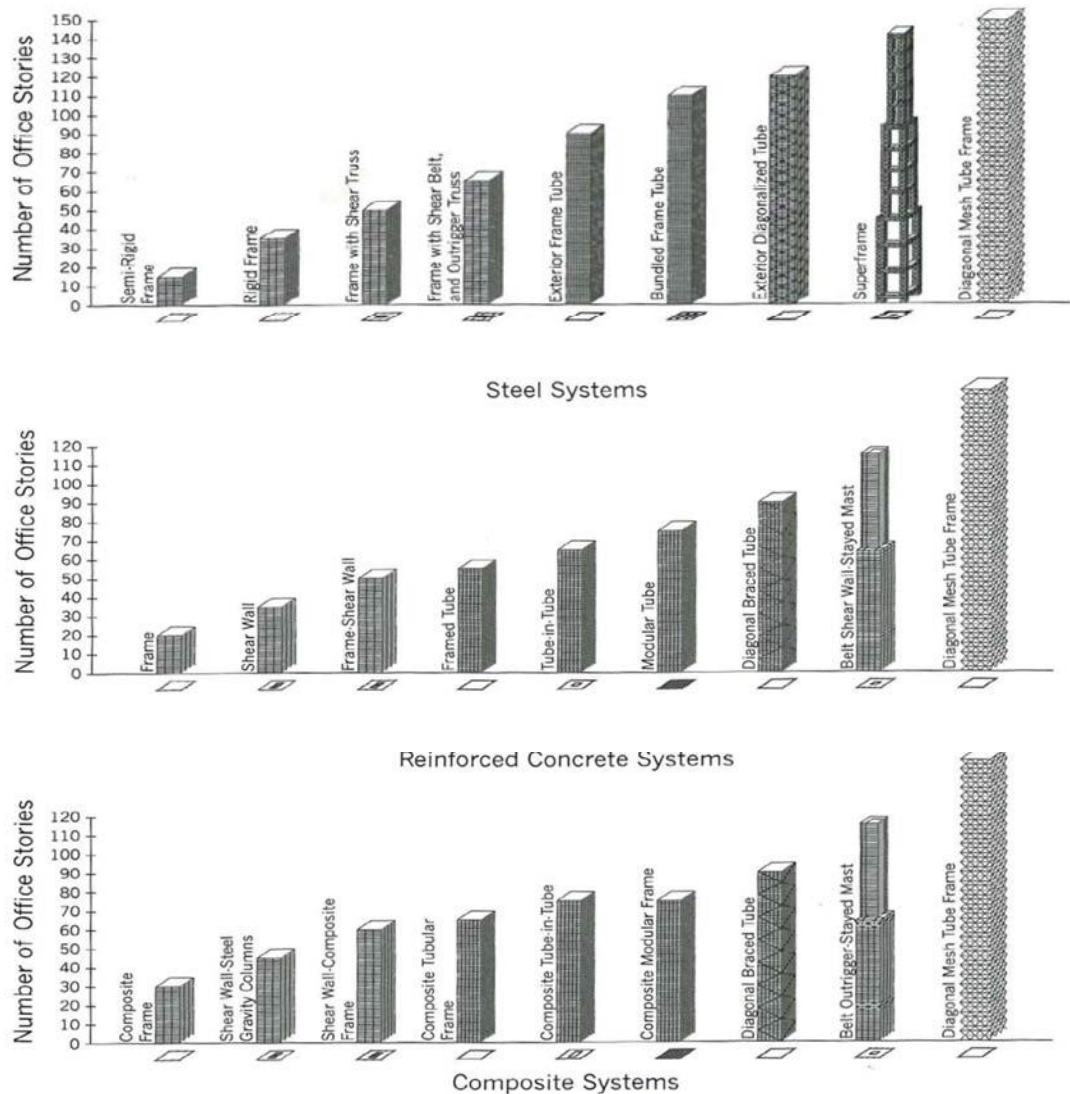

Figure 1.2. Steel, reinforced concrete and composite companions to Khan's structural system hierarchy (Sarkisian, 2011).

1.4. Different Floor Plans of High-Rise Building

Beside the classification of different types of structural systems of high rise buildings, thanks to improvement of new techniques, various floor plans are used by designers. While some floor plans help to create more rentable area in buildings, the others help to resist more lateral loads. Designers take into account, statical and economical issues during the design process of high rise buildings.

The floor plan shape has big impact on the interior space planning, exterior building diagram and structural system significantly. In general, if a building has simpler and regular floor shape, it is easier to adapt building to the designer's needs in terms of space planning. Regular geometric shape such as square and rectangular floor plans work more efficiently than curved and irregular plan shapes. Nevertheless the efficiency of regular shapes, thanks to technological improvements, irregular floor plans are used in practice. Figure 1.3 shows some floor plan examples of high rise buildings.

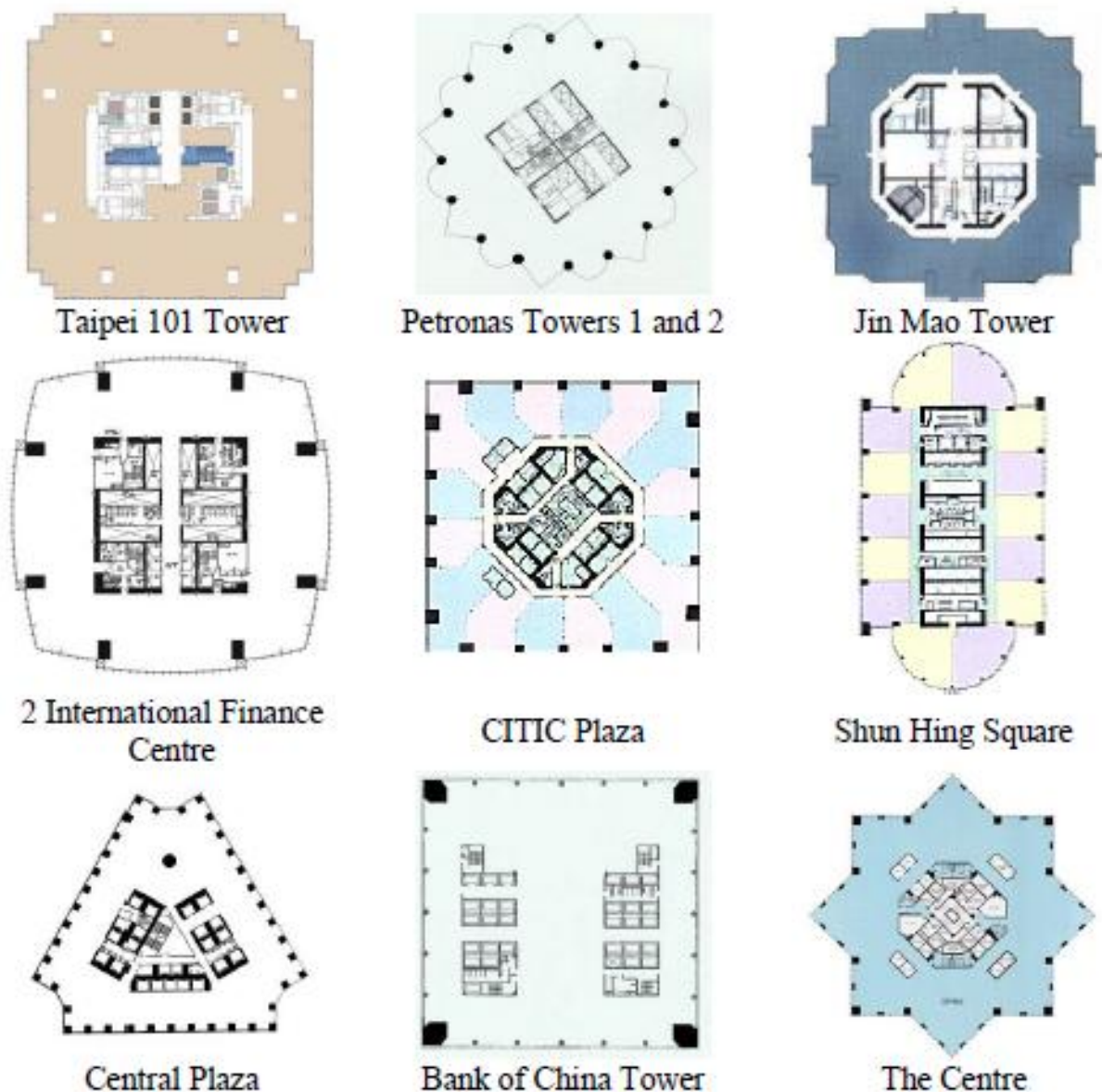

Figure 1.3. Geometry of different floor plans of high-rise buildings (Paul H K Ho, 2007).

The buildings which have unsymmetrical floor plan are more are less sensitive to lateral wind impact than symmetrical plan buildings. This feature especially is important in high-rise buildings. As it is shown in Figure 1.3, in order to succeed planning and structural efficiency there is a tendency of having square plan which enables ease to designers. Since square floor plan provides the same stiffness in each directions against wind forces, square plan is the most common geometry in high-rise buildings as demonstrated by the Jin Mao Tower, Taipei 101 Tower, 2 International Finance Tower, CITIC Plaza and lower floors of the Bank of China Tower. The Central Plaza has triangular floor plan which can be illustrated in Figure 1.3. Whereas The Petronas Towers, Shun Hing Square and Centre have irregular shapes named hybrid shape. Even Petronas Towers and Centre have not regular shape; their layouts are symmetrical about both axes as the square plan. Therefore these two buildings are able to achieve similar planning and structural efficiency.

1.5. Examples in Practice Related with the Design of High-Rise Buildings

Joseph *et al.* (1997) investigated the design process of 451.9 m tall Petronas Twin Towers constructed in Kuala Lumpur, Malaysia. During the design process of this tower a variety of design challenges related to high-rise buildings and slender members under wind load are presented. Figure 1.4 shows the schematic view of the towers. For the core of building cast-in-place high-strength concrete are used. In order to provide economical load-carrying ability, lateral load resistance and inherent damping for residents' comfort the perimeter columns and ring beams are applied in building. To simplify the connections in joints of difficult geometry of building relatively light concrete construction and simple equipment are used. Moreover this concrete structure provided fire rated shaft walls in the core. Steel beams which are located on metal deck slabs supply efficient, economical and quickly erected long-span floors which were easily adaptable to future changes in the building. The hybrid shape tower plan has alternative cantilevered points and arcs. There are only 16 main tower columns. Wind frame ring beams length change from 8.2 m to 9.8 m long.

At levels 41 and 42 of building a unique arch-supported skybridge which is 58.4 m linked towers each other. Here, the towers are able to move more than 300 mm in any direction. A steel pinnacle is located at the top of each tower. For investigating individual tower behavior, pinnacle behavior, skybridge overall behavior and arch leg behavior extensive analytical aero elastic wind studies are carried out. Thanks to pinnacles which have simple chain impact dampers there is no need supplementary damping for the towers. The used steel framing systems allowed utilizing local fabrication and non-crane erection methods during the construction process.

Wind loads acting on the towers were studied by computer models. Some scientific tests such as wind tunnel force-balance and aero elastic models analysis are carried out. After all these tests of skybridge, it is decided to place compact tuned mass dampers within each steel pipe leg reduces vortex-shedding for long fatigue life. For providing additional damping each pinnacle poles have a neoprene-sheathed chain. Pipe rings are connected to create inherent damping between them. Using of mixed construction materials and attention to dynamic effects provided the Petronas Towers to a successful comprehension.

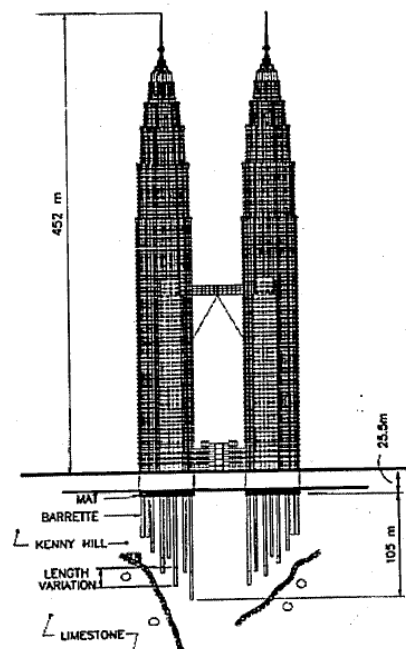

Figure 1.4. Petronas Tower foundation profile (Joseph, 1997).

The Taipei 101 tower was completed in 2004. The name of the towers tells that the tower has 101 floors and it also has 5 basement floors. The maximum height of tower including the spire is 508 m and the top of the last floor is located at 457 m above the ground.

The wind and seismic lateral forces are resisted thanks to a combination of a braced frame core, outriggers, super-columns and moment resisting frames in the perimeter and other locations. Both the core (22.5 m x 22.5m) and columns (3m x 2.4m) are composite columns. In order to reduce the dead weight, both structural members are with concrete up to the 62nd floor. For improving stiffness of building concrete shear walls are placed between the core columns up to the 8th floor. After the 8th floor of building, the core is braced with steel V-braces on the outer faces of the core and with moment resisting steel frames on the inner faces of the core. In every 8th floors of building the core and columns are connected by an outrigger truss system. Either the outrigger trusses are one storey or two story high. This height decisions are decided depending on the position in the building. An outrigger occupies too much space of the story so that the story containing an outrigger is not proper for office usage. The tower is founded on 380 concrete piles which are driven 30 meter into a layer of bedrock. Also, 3-5 m thick concrete slabs are constructed above the piles. The piles are 1.5 m diameter and 80 m long.

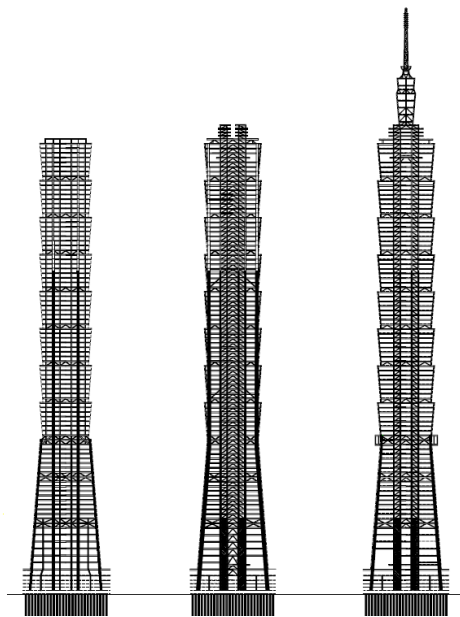

Figure 1.5. Taipei 101 schematic view (Shieh, 2003).

Taipei 101 is located on an area where winds flow too strong and earthquake is a big problem. Therefore, the tower is designed to resist against both lateral load cases. The dominant load is wind for the Taipei 101 tower. Moreover, more specific the wind induced acceleration at the top story such as 7.5 cm/s^2 where 5 cm/s^2 is allowed by the local regulations. The Taipei 101 building has a tuned mass damper at the top levels to reduce the accelerations. Except these the tuned mass dampers' another modification which is chamfered corners was added to the initial design of the tower. Extensive and dense wind tunnel testing demonstrated a decrease of 25% of the base shear force caused by winds when using chamfered corners instead of straight ones.

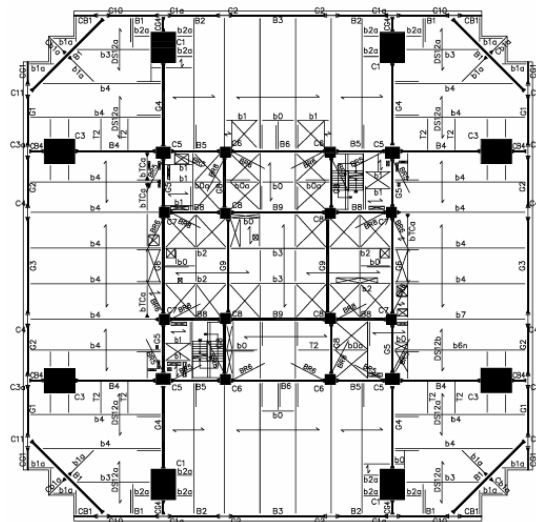

Figure 1.6. Floor plan of Taipei 101 (Chang *et al.*, 2003).

Another high-rise building is The Shanghai World Financial Centre which was completed in 2008. Its height is 492 meters and it was the building with the highest roof top and highest occupied floor at that time. The building contains 101 floors and a three floor parking area. The building is used as office and hotel building.

A combination of 2 structural systems was applied on The Shanghai World Financial Centre. Except having a central core with outriggers, a mega structure in the façade is applied. Reinforced concrete structure material is used for the central core. For decreasing dimensions of the concrete core of building and decreasing self-weight of the total structure, while the stiffness of the perimeter system was increased the lateral stiffness of

this core for resisting wind and earthquake induced loads is decreased. At seven different locations in the building, the core is connected to belt trusses by using outrigger trusses systems. More lateral resistance is provided thanks to adding four mega columns. These columns are made of steel-concrete composite columns. The columns' dimensions are 5.4 m x 5.4 m. By combining the belt trusses which are located at the same elevation as the outrigger trusses, mega diagonals and mega columns, the perimeter structure of building is formed. In order to reduce the weight of building the belt trusses and diagonals are chosen as steel box girders.

It is not explained well which load is chosen as dominant on the design procedure of buildings so that it is assumed that wind loads are dominant load cases in this project too. This assumption is concluded thanks to earthquake analysis. From this analysis it became clear that the tower behaves elastic during its whole lifetime, while a 4% plasticity ratio is allowed. According to this fact it is safe to assume that earthquake loads are not dominant load cases on this building.

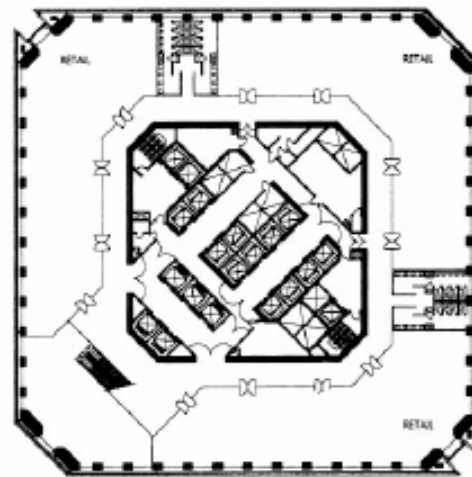

Figure 1.7. Floor plan of Shanghai World Financial Centre (Katz, 2008).

2. OUTRIGGER STRUCTURAL SYSTEM

The function of outrigger system can be defined as creating one combined system by tying together two different systems. These are a core system and a perimeter system. Thanks to having one combined system whole building behaviours became much better than those different two structural systems. Outriggers find amazing usage, for instance, in high rise buildings which utilize dual lateral systems. The locations of outriggers on the building, the number of levels of outriggers provided the presence of belt trusses to engage to adjacent columns and outrigger truss depths affect outrigger system performance mainly.

By utilizing outrigger system to tie together perimeter structural and core structural systems creates unique design to resolve construction problems. Figure 2.1 and Figure 2.2 demonstrate schematic plan view and 3D view of outrigger system on building.

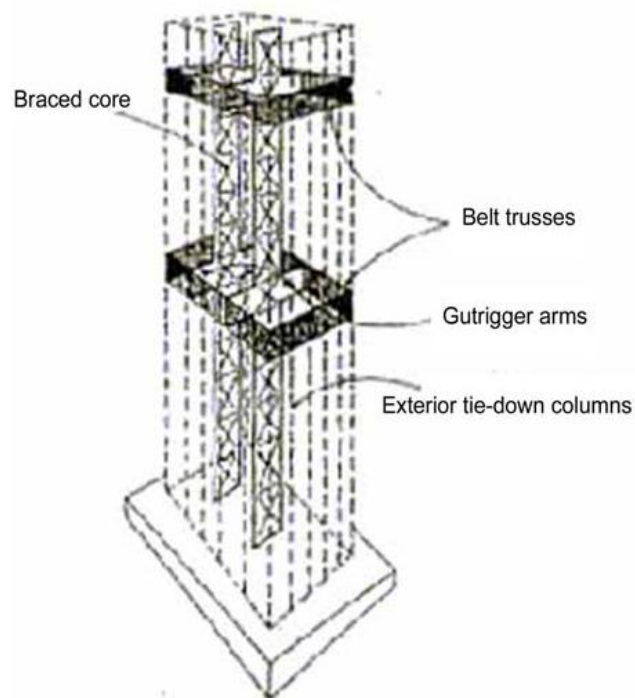

Figure 2.1. Schematic 3D view of outrigger and belt truss system (Smith *et al*, 1996).

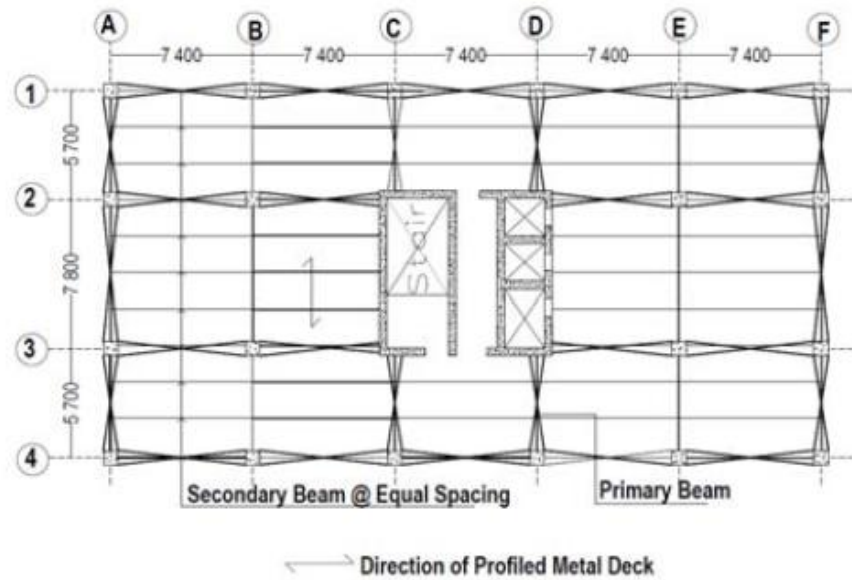

Figure 2.2. Floor layout of outrigger and belt truss system (Fawzia, 2010).

2.1. Background of Outrigger Structural System

Outriggers are designed to improve overturning stiffness of building and to make building stronger by connecting the building core or backbone to distant columns. For almost half a century, outriggers structural systems have been used in tall, narrow buildings for utilizing these features.

Simply, outrigger system behaviour can be explained by emphasizing its way of acting. Because outrigger acts like stiff arms engaging outer columns. Duration tilting of a central column, at the outrigger level its rotation induces a tension-compression couple in the outer columns acting in opposition to that movement. This type of restoring movement at that level can be evaluated as its positive result.

To analyze and design a total core and outrigger system is not easy. The distribution of forces between the core and the outrigger depends on the relative stiffness of each element. Therefore, the stiffness of each element must be evaluated carefully. Moreover, it is predictable that to bring perimeter structural elements together with the core as one, lateral load resisting system will reduce core overturning moment. This is another positive impact of outrigger system.

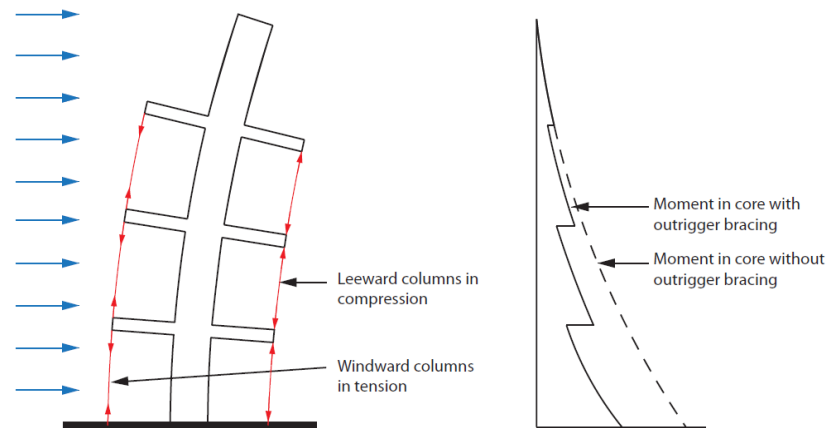

Figure 2.3. Interaction of core and outriggers (Taranath, 1998).

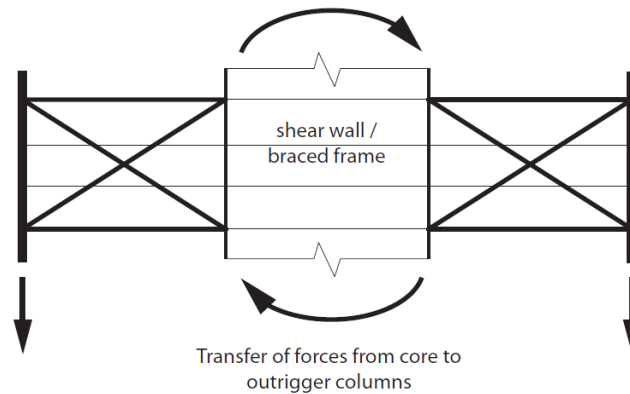

Figure 2.4. Outrigger at core (Nair, 1998).

2.2. Benefits and Challenges of Outriggers

2.2.1. Benefits of Outriggers

Outrigger system has many benefits on high rise buildings. First this system has big impact on reduction of deformation. Any high rise structure that has outrigger system can experience a reduction in core overturning moment up to 40% compared to cantilever (Lame, 2008). For systems with belt trusses that engage all perimeter columns may be capable of resisting outrigger forces with minimal changes in size or reinforcement, when different load factors apply to design combinations with and without lateral loads. In the

event that additional overall flexural stiffness is required, the greater lever arm at outrigger columns makes additional material more effective than in the core (Wada, 1990).

Outrigger system helps to distribute overturning loads on foundations. Also having an outrigger system may change many aspects of foundation design. These aspects can be governing pile loads and footing or mat bearing pressures.

Outriggers and belt trusses may provide to reduce differential vertical shortening between columns, or between a column and the core. Thanks to that, floor slopes between elements which may occur from thermal changes or shrinkage can be reduced.

Moreover different secondary benefits can be mentioned in this section such as elevated torsional stiffness. Because of the small distance between resisting elements a tower which has only core may have low torsional stiffness compared to a perimeter-framed tower. A building consists of a core and outrigger system can have similar low torsional stiffness. Outrigger system can force perimeter columns to act as fibers which provide enormous additional torsional stiffness.

Besides all these benefits outrigger system can give designers to have architectural flexibility. This system permits design variations in exterior columns spacing to satisfy aesthetic goals. High rise buildings with outrigger system may have a few mega exterior columns on each face. This enables designers to have space for creating their aesthetic and architectural expressions.

2.2.2. Disadvantages and Challenges of Outriggers

There are two main disadvantages in using outriggers in the structural system. First, outrigger systems have many vertical elements (diagonals, truss) which might interfere with rentable spaces. Outrigger systems might even be two stories deep. However this problem may be overcome by putting the outrigger in the mechanical level because major mechanical levels are often two story-height spaces which provide good conditions for putting deeper outrigger trusses. Running outriggers in the mechanical floors needs careful

coordination to prevent possible conflicts. In order to permit maintenance, equipments must be located far from walls and trusses.

Another disadvantage is that the optimal erection of a building has a repetitive nature so that the construction staff work with a faster speed, however this is not true when outrigger systems are used in the building. The outriggers have negative impact on the erection of the structure although this can be mitigated by providing clear erection guidelines for the construction staff (CTBUH, 1995).

In addition to these two main disadvantages mentioned above, to put an outrigger system in the design process of a high rise building creates some challenges. These are differential thermal strains and differential vertical shortening. When the core and columns have different temperature conditions as from perimeter columns exposed to weather, force transfers may occur through outrigger. Forces in outriggers from differential temperatures may be so big where columns are fully exposed as the New York Times building but this is not common situation (Scarangelo *et al.*, 2008).

The other challenge of outrigger systems is differential vertical shortening. All buildings experience differential vertical shortening between core and perimeter vertical members acting at different stress under gravity load. Buildings that include concrete columns or walls experience long term vertical deformations due to cumulative creep and shrinkage strains. The magnitude and timing of this kind of deformations differ between members as stresses. This makes prediction of differential movements a complex time and sequence based challenge. Outrigger connections must be designed for possible forces due to differential shortening that occurs between building members.

2.3. Favorable Conditions for Outriggers

All high rise buildings require one core to locate elevators, stairs and other common services. In general, this core is located in the center of floor plan because esthetics reasons and in order to minimize torsional forces. When the core is relatively large in floor plan, this may provide strength against overturning and stiffness against drift. However, a

core becomes efficient when height/core width aspect ratio increases. In the case aspect ratio exceeds eight or so, using outrigger system helps to resist overturning and to control lateral drift of building. Besides that, in some buildings to maintain the building drift/height ratio below criterion, width of core may be thickened. This creates more stiffness building but less rentable area. Using outriggers can decrease the dependence on the core and maximize useful space between core and columns.

Gerasimidis *et al.* (2009) pointed that when direct or conventional outrigger walls or trusses are not admissible for the building because of space limitations or a column layout which isn't aligned with the core walls, an indirect outrigger or belt truss system can be used. In an indirect outrigger belt truss design, corner columns may provide the most overturning resistance. However, if specific attention is not paid to relative stiffness of all system members, corner columns may not attract much of the gravity load. Favorably, the same member sizes work for stiffness and strength.

2.4. Load Transfer Path in Outrigger System

When a structure designed with an outrigger system is loaded laterally, the outriggers resist against core rotation. This resistance is enabled by inducing perimeter columns to push and pull in opposition. The outriggers receive a portion of the core overturning moment. Moreover, windward columns take tension and leeward columns take compression. The same stiff outriggers that constitute interaction between core and columns under lateral loads will also cause interaction under vertical loads. Some effects such as differential shortening, inelastic creep and shrinkage or thermal effects lead to forces being transferred between core and columns by the outriggers.

In concrete systems it is more supposably that columns act at higher stress than core walls under gravity loads. Hence outriggers generally tend to transfer outer column gravity load to the core when core and columns are concrete. With a concrete core and steel perimeter columns, the effect reverses over time as creep and shrinkage causes the core to shorten more. The effects of load transferring may be minimized by controlling construction sequence or using special details on connections.

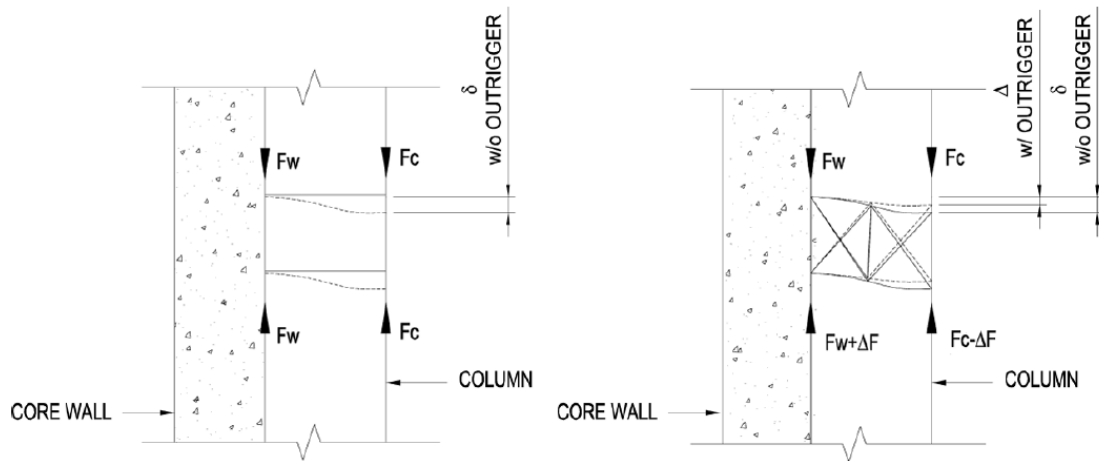

Figure 2.5. Transfer of gravity loads from column to core (Tomosetti, 2001).

2.5. Determining Locations and Numbers of Outriggers

The short load path from column to core by direct outriggers makes them stiff and efficient. In order to achieve the same stiffness benefit, indirect outriggers can be required on more floors than direct outriggers. This exchange is rarely a problem in reality. All outrigger types can also be present in the same building, as where multiple outriggers offer coveted stiffness and strength advantages. However not all outrigger level can accommodate direct outrigger trusses, or where differential shortening is more problematic for direct outriggers at some levels than at others.

Many different optimization criterias such as top floor drift, story drift, etc, can affect optimal outrigger locations for different buildings. As a starting point with one outrigger, a typical attitude says to place it at half of the building height. For systems with two outriggers, 1/3 and 2/3 height of the building can be good starting places for outriggers. If one of the outriggers is located at the top of structure, the second outrigger can be located at 50% to 60% of building height. In the case there are three outriggers, 1/4, 1/2, and 3/4 height of the buildings are favorable places to start design procedure. However, if one of

outriggers is located at the top of the building, the others may be at $1/3$ and $2/3$ height of the building. As mentioned above, for each selection of outrigger locations the realities of space availability and the influence of member size decisions on the system must be considered carefully.

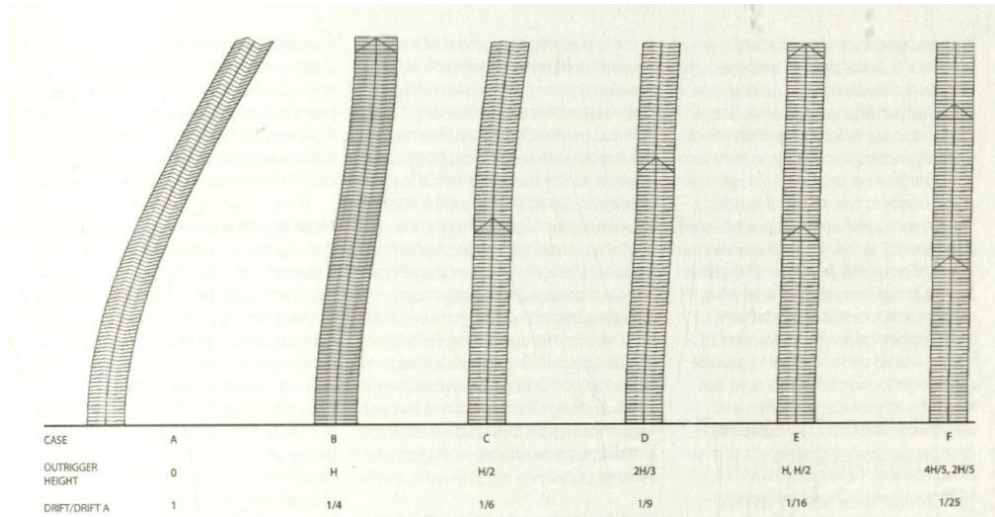

Figure 2.6. Effect of outrigger system location (Tomasetti, 2001).

2.6. Examples of Outriggers in Practice

2.6.1. The First Wisconsin Center

Figure 2.7 demonstrates The First Wisconsin Center. The building has 42 stories and 120.77 meter square area in total the height of the building is 183 m. The building is utilized for a bank and office. This building contains three belt trusses. These belt trusses respectively are located at the bottom, middle and top of the building. The first belt truss which is located at the bottom of the structure acts as a transfer truss. Other two outrigger and belt trusses located at the top and the middle of the structure act as outrigger. All mechanical equipment of building is located at the outrigger floors. Chicago office of Skidmore, Owings & Merrill designed this building (Taranath 1998).



Figure 2.7. First Wisconsin Center, Milwaukee, USA (Taranath, 1998).

2.6.2. One Houston Center

The building which is shown in Figure 2.8 is located in Houston Texas. It has 48-stories. The height of the building is 207.5 m. A 2-story deep outrigger between the 33rd story and 35th story is located on building. The outriggers cannot be seen from outside of building because of the style of façade (Taranath, 1998).



Figure 2.8. One Houston Center, USA (Taranath, 1998).

2.6.3. Place Victoria

The Place Victoria is located in Montreal. It has 47 stories and it was constructed in 1964. The height of the structure is 190 m. This building has an importance that it was the first concrete structure to integrate outriggers. It has four levels of x-braced outriggers which connect the four super corner columns to the core (CTBUH, 1995).



Figure 2.9. Place Victoria in Montreal, Canada (CTBUH, 1995).

3. WIND LOADS ON HIGH-RISE BUILDINGS

In the wind engineering field numerous significant developments took place in the last decades. These developments include the changes of the following: new methods for guessing the across-wind and torsional response of high-rise buildings; improved procedures for guessing the along-wind response of structures;; simple and attentive methods for taking wind directionality effects into account in design; practical procedures for the risk-consistent design of cladding for wind loads, which make it possible to achieve more economical design for any given safety level, or safer design for any given cost.

The ascent of modern construction techniques and innovative materials has resulted in the occurrence of a new generation of structures. These structures are often, flexible, low in damping, and light in weight. Such structures are sensitive to the action of wind. Accordingly, it becomes necessary to develop tools enabling the designer to guess wind effects with a higher degree of attention than was needed in previous times. Wind engineering is the complex discipline that has evolved from efforts which aimed at developing innovative tools.

It is main purpose to provide that the performance of structure subjected to the wind load will be enough during their anticipated life from the perspective of both structural safety and serviceability. In order to obtain this goal, the designer requires information regarding the wind environment, the relation between that environment and the forces which induces on the structure, and the behavior of the building under the action of these forces.

A structure placed in a given flow area is subjected to aerodynamic forces that may be estimated using available results of aerodynamic theory and experiments. However, if the properties of the structure or the environmental circumstances are unusual, it might be essential to examine special wind tunnel tests.

Information about the wind environment required in design procedure contains elements derived from meteorology, micrometeorology and climatology.

For having explanation and description about the basic features of atmospheric flows, meteorology is a great tool. These features can be of considerable significance from a structural design perspective. For instance, in the case of hurricane, in the design of nuclear power plants procedure, presence of a region of low atmospheric pressure at the center of the storm is an important factor.

Main purpose of micrometeorology is to define the detailed structure of atmospheric flows near the ground. The matters of direct concern to the structural designer include the variation of mean speeds with height above ground, the definition of atmospheric turbulence, and the dependence of the mean speeds and of turbulence upon roughness of terrain.

Climatology at given specific geographical areas is concerned with the prediction of wind states. Possibility statements on future wind speeds can be properly explained in wind maps, such as are currently included in many building codes.

Drag forces which take place in the direction of the mean flow and lift forces which take place perpendicularly to that direction are aerodynamic forces. In the case that the interval between the structure elastic center and the aerodynamic center is large, the structure is also subjected to torsional moments. These torsional moments may substantially affect the structural design.

The aerodynamic forces are dependent on time. Because of that, the procedures and methods of structural dynamics may have to be used to decide the response. Moreover, the arbitrary character of this dependence needs that elements of the theory of random vibrations be applied to the analysis. In some certain cases, performing an aero elastic analysis might be essential for a study of the interaction between the aerodynamic and the inertial, damping, and elastic forces. This study aims to investigate the aerodynamic stability of structure.

It can be observed that the modern structure design which is subjected to wind loads needs the usage of information and methods derived from a wide spectrum of sciences. In consequence, methods and techniques have been formed that have significantly improved the designer's ability which enables designers to guess the effects of wind from the perspective of both serviceability and strength. The main objective of this thesis to present the effects of wind on high-rise buildings regarding the provisions of ASCE7-10 design code. Furthermore, the other objective is to describe the complex behavior of the wind. Design wind speeds are attained by utilizing statistical analysis for different wind regions and wind maps are formed by various building codes such as ASCE7-10.

Wind pressure is scaled to square of the wind velocity. Wind velocity changes with time. It can be defined that its variation, namely dynamic properties, and mean velocity, namely static one, define its influences on high-rise buildings. Wind pressure is equal to one over two times air density times square of its velocity.

$$P = \frac{1}{2} \rho_{air} \cdot U^2 \quad (3.1)$$

In Equation (3.1) P is the wind pressure on unit area ρ_{air} is mass of the air in unit volume. Commonly, P is assumed as 1.25 kg/m^3 and U is the mean wind velocity. In order to guess the wind pressure reasonably, there are many effects whose contribution can not be ignored. These effects are terrain roughness on wind speed, wind directionality, geometry of the building and aero elastic phenomena such as vortex shedding, galloping, flutter, buffeting and the shape of high-rise buildings.

Contribution of effects mentioned above are generally added to wind pressure as multiplier coefficients, because the most useful way taking into account these effects is to consider them as multiplies of wind pressure.

3.1. Wind Velocity Variation with the Height

In order to examine wind velocity variation, in the beginning, atmospheric boundary layer concept must be comprehended by considering the fact that within the boundary layer, the wind speed increases with elevation and at the top of the boundary layer obtains the gradient speed. The wind velocity is almost the same as gradient speed outside the boundary layer. This speed might be assumed constant.

3.1.1. The Atmospheric Boundary Layer

The surface of earth acts on the moving air a horizontal drag force, the effect of which is to slow down the flow. By mixing throughout a region referred to as the atmospheric boundary layer this effect is distributed by turbulent. In the situation of neutrally stratified flows, the boundary layer depth generally ranges from a few hundred meters to a few kilometers. This change depends on wind intensity, roughness of terrain, and angle of latitude. In the boundary layer, the wind speed increases with elevation; its magnitude at the top of the boundary layer is generally referred to as the gradient speed. Outside the boundary layer, that is, in the free atmosphere, the wind flows almost with the gradient speed along the isobars.

Since the structural engineer is concerned primarily with the effect of strong winds, it is assumed that the flow is objectively stratified. The reason of this assumption is that, in strong winds, mechanical turbulence governs the heat convection by far, so that through turbulent mixing tends to produce neutral stratification.

The boundary conditions can be explained by stating that at the ground surface level the velocity vanished, while at an elevation from the ground equal to the boundary layer thickness, the shear stress vanish and the wind flows with the gradient velocity. By using both logarithmic law and power law, the wind velocity profile in boundary layer is modeled.

3.1.2. The Logarithmic Law

The logarithmic law is shown in Equation (3.2). This formula is known as "law of the wall". It depicts the wind velocity profile depending on the shear velocity of the ground. Shear velocity goes up with the decline in roughness length of ground and vice versa ($k \cong 0.4$ is assumed),

$$U(z) = \frac{1}{k} u_* \ln \frac{z}{z_0} \quad (3.2)$$

where the z is the height from the surface, z_0 is the roughness length, and $U(z)$ is the mean wind speed at height z . Figure 3.1 shows comparison of the wind profile of logarithmic profile with the profile of wind tunnel test. δ is the boundary layer height and z_l is the height of validity of the logarithmic law. The linear line indicates the logarithmic profile and the other line is the actual wind velocity profile. After a particular height, law of the wall does not encounter with actual wind velocity profile and overestimates the results.

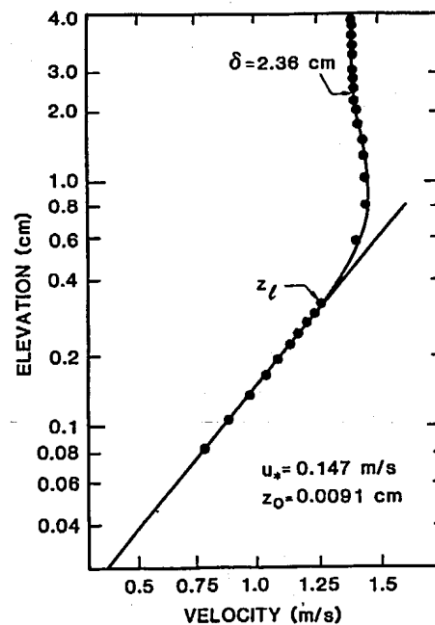

Figure 3.1. Mean wind profile as measured in a rotating wind tunnel (Simiu and Scanlan, 1986).

3.1.3. The Power Law

The power law (Simiu and Scanlan 1986) represents the mean wind profile in horizontally homogeneous terrain by Equation (3.3),

$$U(z_{g1}) = U(z_{g2}) \left(\frac{z_{g1}}{z_{g2}} \right)^\alpha \quad (3.3)$$

where α is an exponent dependent upon roughness of terrain and z_{g1} and z_{g2} denote heights above ground and U represents the wind velocity at a certain height.

An alternative of power law (Simiu and Scanlan 1986) held with constant exponent α up to the boundary layer height δ , and that δ itself was a function of α alone in Equation (3.4) below,

$$\frac{U(z_g)}{G} = \left(\frac{z_g}{\delta} \right)^\alpha \quad (3.4)$$

where G is the gradient speed at the top of the boundary layer height δ is the boundary layer height and U is the wind speed at some height z_g . Values of δ and α recommended for design purposes are demonstrated in Table 3.1.

Table 3.1. Values of δ and α .

	Coastal Areas		Open Terrain		Suburban Terrain		Centers of Large Cities	
	α	$\delta(m)$	α	$\delta(m)$	α	$\delta(m)$	α	$\delta(m)$
Simiu and Scanlan 1986	-	-	0.16	275	0.28	400	0.40	520
ASCE7	1/9	215	1/6.5	275	1/4	365	1/3	457

3.1.4. Relation between Wind Speeds in Different Roughness Regimes

Two adjacent areas assumed to have uniform roughness and large enough fetch. The roughness lengths for two areas are represented by z_0 and z_{01} and assumed $z_0 > z_{01}$. The deceleration of the flow by surface friction is more influential over the rougher area. Thus, if the gradient speed is the equal over for each site, at equal elevations the mean wind speeds will be lower over the rougher site. In Figure 3.2 a schematic representation of the respective wind profiles is demonstrated. The profiles of Figure 3.2 recommend the following method for relating wind speeds in various roughness regimes. For the calculation of the wind speed $U(z_{g1}, z_{01})$ is known, Equation (2.4) is applied to each profile. After that the quantity G is removed from the two relations thus obtained,

$$U(z_g, z_0) = \left(\frac{z_g}{\delta(z_0)} \right)^{\alpha(z_0)} \left(\frac{\delta(z_{01})}{z_{g1}} \right)^{\alpha(z_{01})} U(z_{g1}, z_{01}) \quad (3.5)$$

where $\alpha(z_0)$ and $\alpha(z_{01})$ are power law exponents, $\delta(z_0)$ and $\delta(z_{01})$ are the boundary layer heights, z_g and z_{g1} are the corresponding heights at which the wind velocities attained, $U(z_g, z_0)$ and $U(z_{g1}, z_{01})$ are wind velocities, z_0 and z_{01} surface roughness lengths in source and destination terrains, respectively (Simiu and Scanlan 1986).

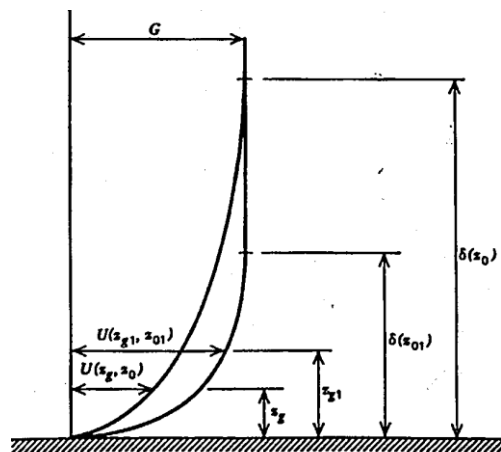

Figure 3.2. Wind velocity profiles in different roughness regimes (Simiu and Scanlan, 1986).

3.1.5. Atmospheric Turbulence

Wind speed changes randomly in time. This variation occurs because of the turbulence of the wind flow. For three important reasons, information on the features of atmospheric turbulence is beneficial in structural engineering practices. First, rigid structures and elements are exposed to time - dependent loads with fluctuations due in part to atmospheric turbulence. Second, flexible buildings may reveal resonant amplification effects induced by velocity changes. Third, the aerodynamic behavior of structures and the results of tests which are carried out in the laboratory may base on the turbulence in the airflow (Simiu and Scanlan, 1986).

3.2. Drag, Lift and Pressure Coefficients in Wind Flow

If a bluff body section is embedded in a wind flow of velocity U , the flow develops local pressure p over the body compatible with Bernoulli's Equation,

$$\frac{1}{2} \rho_{air} . U^2 + p = \text{constant} \quad (3.6)$$

where ρ_{air} is the mass of air in unit volume, the constant keeps along a streamline and U is the velocity on the streamline in the immediate vicinity of the body that shapes on its surface. The integration of the pressures over the body surface ends up a net force. The components of the force in the along-flow and the across-flow directions are commonly known as drag and lift, respectively. Drag force is the net force in the flow direction and lift force is the net force perpendicular to the flow direction. These integration quantities which are drag and lift quantities are so apparently attracted by the Reynolds number and the shape of the body. It is general to mean all pressures measured at a structural surface to the mean dynamic pressure $\frac{1}{2} \rho_{air} . U^2$ of the far upstream wind of the free-stream wind at some distance from the building. Hence, nondimensional pressure coefficient C_p is represented by,

$$C_p = \frac{p - p_o}{\frac{1}{2} \rho_{air} U^2} \quad (3.7)$$

where U is the mean value of the reference wind and $p - p_o$ denotes the pressure difference between local and far upstream pressure, p_o . Such non-dimensional shapes permit the transfer of model experimental results to full scale. Moreover, the establishment of reference values for cataloguing the aerodynamic properties of shown geometries (Simiu and Scanlan 1986).

Drag force is the net force in the flow direction and lift force is the net force which is perpendicular to the flow direction. Similarly, the net wind-pressure force F_L and F_D in the lift and drag direction, respectively, can be attained dimensionless and expressed with regard to lift and drag coefficients C_L and C_D as follows,

$$C_L = \frac{F_L}{\frac{1}{2} \rho_{air} U^2 B_B H_B} \quad (3.8)$$

$$C_D = \frac{F_D}{\frac{1}{2} \rho_{air} U^2 B_B H_B} \quad (3.9)$$

where B_B and H_B are reference dimensions of the body perpendicular to the flow direction, U is the mean wind velocity and ρ_{air} is the mass of air in unit volume.

4. SEISMIC DESIGN CRITERIA OF HIGH-RISE BUILDINGS

4.1. Introduction and Background

There is a big demand of high rise building construction all around the world. These buildings' strength and safety have to be investigated by considering seismic effects. The seismic design of high rise buildings varies from country to country strikingly. However, detailed performance based assessments are required in some countries; many other countries do not require anything beyond traditional design practice. These traditional design practices are based on fundamental mode response and force reduction factors. In many countries' seismic codes enable the designer to solve their general problems during design process. Despite the fact that, the provisions of these codes are used for the design of high rise buildings in many countries, they are not suitable as the seismic design basis for high rise buildings for some reasons.

First reason, the all national codes were developed for low and medium rise buildings. These buildings' responses are dominated by the first translational mode in each horizontal direction generally. So this shows that codes are not for the modern kind of high-rise buildings because in high-rise buildings, multiple modes of translational response contribute to the global behavior.

The codes allow just a limited number of structural systems for specific height of buildings which are not practical or economical for high-rise buildings.

The codes are based on elastic methods of analysis using global force reduction factors, which cannot predict, force, drift and acceleration response in high rise building framing systems. The framing system receives significant inelastic action. Nonlinear response-history procedures must be utilized to guess these effects. Because of these provisions in the codes mentioned above, different kind of design philosophies must be adopted to high rise building seismic design procedures.

4.2. Design Objectives and Philosophy

The seismic performance objectives of high rise buildings are based on the performance expectations which are in the codes provisions. The expectations of buildings designed according to codes which are aimed to provide some purposes. These are resisting minor earthquake ground shaking, without damage to structural and non-structural components, resisting rare earthquake ground shaking, with damage to structural and non-structural components, but without substantial loss of life and resisting the strongest earthquake shaking ever likely to occur at the site with substantial damage but a very low probability of collapse. Turkish Earthquake Code 2007 aimed same purposes for structures in Turkey. These performance objectives have formed the basis of structural design of many high rise buildings over the last a few decades.

Performance based design of high rise buildings should consist of two performance objectives whereas conventional codes attempt to satisfy all three objectives by designing to prescriptive rules for a single level of seismic hazard.

- Designing the building which is negligible damage for earthquake shaking demands. This objective is achieved by requiring elastic structural response, designing non-structural components and designing building systems to remain operable after the expected levels of motion. At this place, this performance objective is termed the service level assessment.
- Designing the building which has collapse prevention under the largest earthquake shaking. Collapse prevention is achieved by demonstrating two factors. First, inelastic deformation demands in all ductile structural elements are smaller than their deformation capacities, and force demands in components with non-ductile failure modes are less than nominal strengths. Consideration should be given to limiting damage to those non-structural elements whose failure could trigger collapse of the building. Herein, this design objective is termed the collapse-level assessment.

4.2.1. Deformation Based Design Philosophy

Deformation is the key parameter in performance-based seismic design rather than force which is used in traditional design codes. The reason of that, performance is characterized by the level of damage. The damage is related to the degree of elastic and inelastic deformation in elements and systems. Deformations in the building can be classified into three types. These are story drifts, overall building movement, and inelastic deformations of structural elements respectively.

The overall building movement gives a superficial assessment of building performance. However all deformation quantity of building can provide some measure of the significance of $P - \Delta$ effects.

Story drift, which can be defined as the relative lateral displacement of two adjacent floors, can form the starting point for assessment of damage to non-structural elements. However, it is more informative in high-rise buildings to assess these relative movements in each story as elements due to rigid body displacement and shear deformation.

Rigid body displacement is related to the rotation of the building as a whole at upper levels due to vertical deformations in the columns below, and induces no damage. Racking shear deformation (β) is a measure of the angular in-plane deformation of a wall or panel. This will in general change at different positions on a floor, and may exceed the story drift ratio (α) in some locations. In the two panels of Figure 4.1, these distinctions are demonstrated clearly (CTBUH 2005).

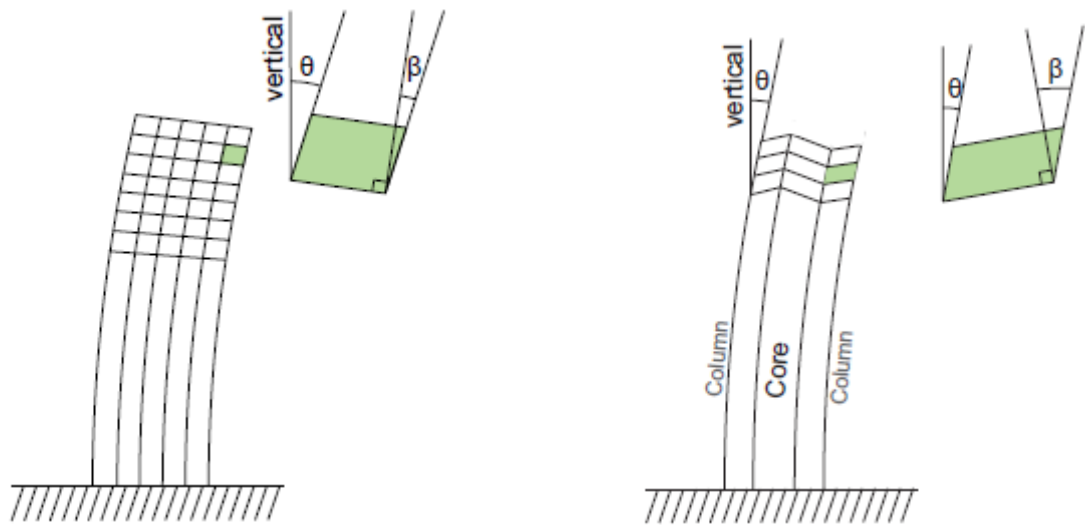

Figure 4.1. Deformation parameters for high rise buildings (CTBUH, 2005).

Inelastic element deformations shape the basis for assessment of structural damage and structural collapse potential. In general, by comparing deformation demands with admissible values based on structural details and member forces assessments are performed one component at a time.

4.3. Seismic Structural Analysis and Modelling

Seismic analysis according to various factors can be carry out by applying different methods. Elastic analysis is one of them. Before applying these methods detailed 3D finite element models should be prepared. The elastic analysis is generally appropriate for the service level assessment because, the responses of component are smaller than those which cause yielding generally.

Nonlinear response-history analysis is needed for the collapse prevention level evaluation. In the case, it can not be depicted that all structural components do not yield for maximum earthquake shaking. If it can not be shown to have unimportant effect, vertical excitation should be evaluated in combination with the dual horizontal excitation.

The pushover analysis is a nonlinear static analysis. This analysis method should not be utilized for analysis of high rise buildings because this method of analysis cannot capture the higher mode effects and torsion that are crucial in such structures. Moreover it can not be extended to accommodate additional damping devices easily. Consequently, nonlinear response history analysis is required for high rise buildings. According to provisions of this type of analysis numerical modelling has to be created by designer.

For numerical modelling of structural components in high rise buildings, basic principles are described respectively. First, the numerical model of the building should be detailed enough in order to enable consideration of the interaction of all structural. Second numerical model should be detailed for non-structural elements which affect nonlinear and the linear response of the building. Mathematical model of building should contain all structural components and non-structural components whose stiffness and mass contribute to the dynamic response of the building. Gravity framing will often significantly affect the seismic performance of a high-rise building. Because of this reason such framing should be included in the mathematical model as well. The basic principles of mass and damping are given to clarify the contents of numerical model.

The reactive mass included in the model should be the best estimate of the structural mass, the constant exposed mass including fixed furniture, finishes and mechanical components. Some provisions need a small proportion of the live load to be included as a permanent load. In the improvement of the mathematical model, the influence of finite joint size, beam-column joint flexibility, and the effect of secondary structural elements should be considered in any conditions of the structural material. Thanks to these considerations, the contribution of mass on numerical model can be attained precisely.

Another significant parameter of mathematical modelling is damping. According to structural geometry, architectural properties of structure and the selection of materials in high-rise buildings the damping varies. Moreover, the level of damping varies depending on demand level as in a concrete structure where concrete cracking and reinforcing steel yielding may take place even under service level gravity loads. The structural engineer

should carefully consider each of these factors when selecting a damping level for the analysis level under consideration.

In addition to these parameters, some facts about floor diaphragm should be taken into consideration. During analysis procedure the assumption that rigid diaphragm is rigid in the floor plane must be emphasized. If not by using shell elements, the diaphragm can be modeled as flexible. In order to have clear calculations of collector forces and transferred forces from other load distribution elements, each diaphragm should be modeled in high rise buildings.

4.4. Elastic Analysis

Response spectrum and response-history analysis are both acceptable elastic analysis procedures for high rise buildings. Elastic analysis is suitable in such case the demand on each structural elements is less than its nominal strength. In general this kind of analysis is valid for the service level evaluations.

Response-spectrum analysis is a linear-dynamic statistical analysis method. In order to indicate the likely maximum seismic response of an essentially elastic structure this method measures the contribution from each natural mode of vibration. By measuring, velocity, pseudo-spectral acceleration or displacement as a function of structural period for a given time history and level of damping response-spectrum analysis gives better understanding of dynamic behavior. Enveloping response spectra such a decent curve which stands for the peak response for each actualization of structural period is practical for response-spectrum analysis method.

In the case response-spectrum analysis is utilized for seismic design procedure, a enough number of modes must be included to have 95% of the whole building mass above the level at which the earthquake shaking is input to the building along each axis of the building. For combining modal responses the CQC (Complete Quadratic Combination) method should be utilized and the effects of multidirectional loading should be considered during the analysis procedure.

The other elastic analysis method is linear response history analysis which is the determination of the response of a mathematical structural model to actual recorded, simulated, or artificial earthquake records. Linear response history analysis has many advantages. These advantages are methods' ability to preserve the signs of component forces, reactions and displacements as well as its explicit handling of dynamic behavior. As mentioned above these two analysis methods are both acceptable for elastic analysis.

4.5. Non-linear Response History Analysis

Nonlinear response-history analysis should be utilized for all evaluation that contains significant nonlinear response in structural members. In general nonlinear analysis will be essential requirement for the collapse prevention level assessment. In the nonlinear response-history analysis second order effects that include all of the building dead load and permanent live load have to be included.

Despite the fact that, a number of finite element codes contain competence for this type of analysis the results obtained can be strongly affected by the designer's choice about damping specification, time-step, and element variety.

5. DESIGN PROVISIONS

5.1. General Design Provisions

ASCE7-10 "Minimum Design Loads for Buildings and Other Structures" provides minimum load requirements for the design of buildings and other structures that are subject to building code requirements. Loads and appropriate load combinations, which have been developed to be used together, are set forth for strength design and allowable stress design. In this thesis, strength design procedure is implemented for our designed 40 and 60 story buildings. Buildings and other structures shall be designed and constructed to support safely the factored loads in load combinations without exceeding the appropriate strength limit states for the material of construction.

In ASCE7-10 buildings and other structures shall be classified based on the nature of the occupancy for the purposes of applying flood, wind, snow and earthquake provisions. The categories range from 1 to 5. In this study, our designed buildings conform to 2. class.

Table 5.1. Risk category of buildings and other structures for flood, wind, snow, earthquake, and ice loads (ASCE7-10).

Use or Occupancy of Buildings and Structures	Risk Category
Buildings and other structures that represent a low risk to human life in the event of failure	I
All buildings and other structures except those listed in Risk Categories I, III, and IV	II
Buildings and other structures, the failure of which could pose a substantial risk to human life.	III
Buildings and other structures, not included in Risk Category IV, with potential to cause a substantial economic impact and/or mass disruption of day-to-day civilian life in the event of failure.	
Buildings and other structures not included in Risk Category IV (including, but not limited to, facilities that manufacture, process, handle, store, use, or dispose of such substances as hazardous fuels, hazardous chemicals, hazardous waste, or explosives) containing toxic or explosive substances where their quantity exceeds a threshold quantity established by the authority having jurisdiction and is sufficient to pose a threat to the public if released.	
Buildings and other structures designated as essential facilities. Buildings and other structures, the failure of which could pose a substantial hazard to the community. Buildings and other structures (including, but not limited to, facilities that manufacture, process, handle, store, use, or dispose of such substances as hazardous fuels, hazardous chemicals, or hazardous waste) containing sufficient quantities of highly toxic substances where the quantity exceeds a threshold quantity established by the authority having jurisdiction to be dangerous to the public if released and is sufficient to pose a threat to the public if released. Buildings and other structures required to maintain the functionality of other Risk Category IV structures.	IV

5.1.1. Wind Loads

The design wind loads for buildings and other structures, including the main wind force resisting system, component and cladding element thereof, shall be determined using one of the following procedures ;

- Simplified Procedure
- Analytical Procedure
- Wind Tunnel Procedure

An enclosed or partially enclosed building whose design wind loads are determined according to simplified procedure shall meet conditions. First, the building is a simple diaphragm building so that wind loads are transmitted through floor and roof diaphragms to the vertical main wind force resisting systems. Second, the building has roof slopes less than 10° . Also, the mean roof height of building is less than nine meters and the building has no expansion joints and separations.

A building or structure whose design wind loads are determined according to analytical procedure shall meet the conditions. First, the building is regular shaped building or structure having no unusual geometrical irregularity in spatial form. Second, the building or other structure does not have response characteristics making it subject to across wind loading, vortex shedding, instability due to galloping or flutter; or does not have a site location for which channeling effects or buffeting in the wake of upwind obstructions warrant special consideration.

There shall be no reduction in velocity pressure due to apparent shielding afforded by buildings and other structures or terrain features. Regional climatic data shall be used just in lieu of the basic wind speeds given in basic wind speed maps approved extreme-value statistical-analysis procedures have been employed in reducing the data and the length of

record, sampling error, averaging time, anemometer height, data quality, and terrain exposure of the anemometer have been taken into account.

In hurricane-prone regions, wind speeds derived from simulation techniques shall only be used in lieu of the basic wind speeds in basic wind speeds when approved simulation or extreme value statistical analysis procedures are and the design wind speeds resulting from the study shall not be less than the resulting 500-year return period wind speed divided by $\sqrt{1.5}$.

Wind tunnel tests shall be used where properties of the building or structure do not conform the limitations of simplified and analytical procedures. Wind tunnel testing shall be permitted in lieu of simplified or analytical procedure for any building or structure.

Wind tunnel tests, or similar tests employing fluids other than air, used for the determination of design wind loads for any building or other structure, shall be conducted in accordance with following requirements;

- The natural atmospheric boundary layer has been modeled to account for the variation of wind speed with height.
- The relevant macro-(integral) length and micro length scales of the longitudinal component of atmospheric turbulence are modeled to approximately the same scale as that used to model the building or structure.
- The modeled building or other structure and surrounding structures and topography are geometrically similar to their full-scale counterparts, except that, for low-rise buildings meeting the requirements of analytic procedure
- The projected area of the modeled building or other structure and surroundings is less than 8 percent of the test section cross-sectional area unless correction is made for blockage.

- The longitudinal pressure gradient in the wind tunnel test section is accounted for.
- Reynolds number effects on pressures and forces are minimized and response characteristics of the wind tunnel instrumentation are consistent with the required measurements.

5.1.2. Other Loads

Except wind and earthquake loads, loads which are included design procedures can be classified in three different parts.

- Dead Loads
- Live Loads
- Earthquake Loads

5.1.2.1. Dead Loads

Dead loads consist of the weight of all materials of construction incorporated into the building including, but not limited to, walls, floors, roofs, ceilings, stairways, built-in partitions, finishes, cladding, and other similarly incorporated architectural and structural items, and fixed service equipment including the weight of cranes.

In determining dead loads for purposes of design, the actual weights of materials and constructions shall be used provided that in the absence of definite information, values approved by the authority having jurisdiction shall be used. In determining dead loads for purposes of design, the weight of fixed service equipment, such as plumbing stacks and risers, electrical feeders, and heating, ventilating, and air conditioning systems shall be included.

In this study, uniform floor weight (2.2 kN/m^2) and weight of structural items (columns, beams and braces) are taken as dead load. The other items such as stairways, fixed service equipments etc. are ignored.

5.1.2.2. Live Loads

Live loads, produced by the use and occupancy of the building or other structure and do not include construction or environmental loads such as wind load, snow load, rain load, earthquake load, flood load or dead load. Live loads on a roof are those loads produced during maintenance by workers, equipment and materials; and during the life of the structure by movable objects such as planters and by people.

The live loads used in the design of buildings and other structures shall be the maximum loads expected by the intended use or occupancy but shall in no case be less than the minimum uniformly distributed unit loads required by related building occupancy. Since the subject structure in this paper is an office type building, live load is chosen as uniform 2.5 kN/m^2 from the table about live loads in ASCE7-10.

The minimum uniformly distributed live loads, L_o , may be reduced by the reduction factor determined in Equation (5.1). This reduction is limited for the members which a value of $K_{LL} A_T$ is 37.16 m^2 (400 ft^2) or more.

$$L = L_0 \left(0.25 + \frac{4.57}{\sqrt{K_{LL} A_T}} \right) \quad (5.1)$$

where:

L = Reduced design live load per square foot (m^2) of area supported by the member.

L_o = Unreduced design live load per square foot (m^2) of area supported by the member

K_{LL} = Live load element factor

A_T = Tributary area, in square feet (m^2).

L shall not be less than $0.50L_o$ for members supporting one floor and L shall not be less than $0.40L_o$ for members supporting two or more floors.

Table 5.2. Live load element factor, K_{ll} (ASCE7-10).

Element	K_{ll}
Interior Columns	4
Exterior columns without cantilever slabs	4
Edge columns with cantilever slabs	3
Corner columns with cantilever slabs	2
Edge beams without cantilever slabs	2
Interior beams	2
All other members not identified above including:	
Edge beams with cantilever slabs	1
Cantilever beams	1
Two-way slabs	1
Members without provisions for continuous shear transfer normal to their span	1

5.1.2.3. Earthquake Loads

The specified earthquake loads are based upon post-elastic energy dissipation in the structure, and because of this fact, the requirements for design, detailing, and construction shall be satisfied even for structures and members for which load combinations that do not contain earthquake loads indicate larger demands than combinations that include earthquake loads.

5.1.2.4. Structural Analysis and Procedures of Earthquake Loads

The seismic analysis and design procedures to be used in the design of building structures and their components shall be as prescribed in this section. The design ground motions shall be assumed to occur along any horizontal direction of a structure. The design seismic forces, and their distribution over the height of the building structure, shall be established in accordance with one of the procedures of equivalent lateral force procedure and modal analysis procedure and the corresponding internal forces and deformations in the members of the structure shall be determined using a linearly elastic model. An applied alternative procedure shall not be used to establish the seismic forces and their distribution unless the corresponding internal forces and deformations in the members are determined using a model consistent with the procedure adopted.

Individual members, including those not part of the seismic force-resisting system, shall be provided with adequate strength to resist the shears, axial forces, and moments determined in accordance with these provisions, and connections shall develop the strength of the connected members or the forces indicated previously.

A continuous load path, or paths, with adequate strength and stiffness shall be provided to transfer all forces from the point of application to the final point of resistance.

The foundation shall be designed to resist the forces developed and accommodate the movements imparted to the structure by the design ground motions. The dynamic nature of the forces, the expected ground motion, the design basis for strength and energy dissipation capacity of the structure, and the dynamic properties of the soil shall be included in the determination of the foundation design criteria.

5.1.2.5. Structural Irregularities

Structural irregularities are shown in ASCE7-10 are written item by item below;

- Torsional irregularity is defined to exist where the maximum story drift, computed including accidental torsion, at one end of the structure transverse to an axis is more than 1.2 times the average of the story drifts at the two ends of the structure along the axis being considered. Torsional irregularity requirements in the reference sections apply only to structures in which the diaphragms are rigid or semi-rigid.
- Extreme torsional irregularity is defined to exist where the maximum story drift, computed including accidental torsion, at one end of the structure transverse to an axis is more than 1.4 times the average of the story drifts at the two ends of the structure along the axis being considered. Extreme torsional irregularity requirements in the reference sections apply only to structures in which the diaphragms are rigid or semi-rigid.
- Reentrant corner irregularity is defined to exist where both plan projections of the structure beyond a reentrant corner are greater than 15% of the plan dimension of the structure in the given direction.
- Diaphragm discontinuity irregularity is defined to exist where there is a diaphragm with an abrupt discontinuity or variation in stiffness, including one having a cutout or

open area greater than 50% of the gross enclosed diaphragm area, or a change in effective diaphragm stiffness of more than 50% from one story to the next.

- The vertical lateral force-resisting elements are not parallel to the major orthogonal axes of the seismic force-resisting system.
- Discontinuity in a lateral force-resistance path, such as an out-of-plane offset of at least one of the vertical elements.

Vertical structural irregularities are shown in ASCE7-10 are written item by item below;

- Stiffness-soft story irregularity is defined to exist where there is a story in which the lateral stiffness is less than 70% of that in the story above or less than 80% of the average stiffness of the three stories above.
- Stiffness-extreme soft story irregularity is defined to exist where there is a story in which the lateral stiffness is less than 60% of that in the story above or less than 70% of the average stiffness of the three stories above.
- Weight irregularity is defined to exist where the effective mass of any story is more than 150% of the effective mass of an adjacent story. A roof that is lighter than the floor below need not be considered.
- Vertical geometric irregularity is defined to exist where the horizontal dimension of the seismic force-resisting system in any story is more than 130% of that in an adjacent story.
- In-plane discontinuity in vertical lateral force-resisting elements irregularity is defined to exist where there is an in-plane offset of a vertical seismic force-resisting element resulting in overturning demands on a supporting beam, column, truss, or slab.

- Discontinuity in lateral strength–weak story irregularity is defined to exist where the story lateral strength is less than 80% of that in the story above. The story lateral strength is the total lateral strength of all seismic-resisting elements sharing the story shear for the direction under consideration.

Discontinuity in lateral strength–extreme weak story irregularity is defined to exist where the story lateral strength is less than 65% of that in the story above. The story strength is the total strength of all seismic-resisting elements sharing the story shear for the direction under consideration

5.1.3. Load Combinations

The load combinations and load factors given in ASCE7-10 are used by designing buildings and other structures. Where elements of a structure are designed by a particular material standard or specification, they shall be designed exclusively by following combinations and symbols.

These symbols are representing the loadings which are used in these combinations. Some symbols which are given here are not considered in the design of high rise buildings. These are flood load and load due to lateral earth pressure.

D = dead load

E = earthquake load

F = load due to fluids with well-defined pressures and maximum heights

F_a = flood load

H = load due to lateral earth pressure

L = live load

L_r = roof live load

R = rain load

S = snow load

W = wind load

Structures, components, and foundations shall be designed so that their design strength equals or exceeds the effects of the factored loads in the following combinations.

- $1.4D$
- $1.2D + 1.6L + 0.5(L_r \text{ or } S \text{ or } R)$
- $1.2D + 1.6(L_r \text{ or } S \text{ or } R) + (L \text{ or } 0.5W)$
- $1.2D + 1.0W + L + 0.5(L_r \text{ or } S \text{ or } R)$
- $1.2D + 1.0E + L + 0.2S$
- $0.9D + 1.0W$
- $0.9D + 1.0E$

6. DESCRIPTION OF THE STRUCTURAL SYSTEM OF ANALYZED BUILDINGS

In this study the buildings will be investigated are forty-story and sixty-story buildings. These buildings are made of steel elements and composed of a rectangular floor plan. Heights of all floors are chosen 3.5 m and heights of buildings are 140 m and 210 m respectively. The floor to floor height chosen is also being used as a general practice in offices to ease masking of the wiring etc. Except shear wall core system of buildings the rest of elements are steel structural elements. Floor types are composite deck elements and they are considered as loadings in these models. In this study, floor and footing design and connections' designs are ignored consciously. The buildings are modeled and designed in SAP2000 structural analysis computer program. That means all analyses are not applied in a real building. Despite that fact, still all calculations can be assumed to give applicable results for construction processes. The floors of examined buildings are modeled as rigid diaphragm in each story.

Structural system is outrigger and belt-trussed frame with core system. 3D views of buildings without outrigger-belt truss systems are demonstrated in Figure 6.1 and Figure 6.2. Apart from these two 3D views, systems with belt-trussed frame views are demonstrated in Figure 6.3 and Figure 6.4. A typical floor plan has been selected with 5 equal bays (7.4 m) in long direction (x-direction). In short direction (y-direction) 3 bays of different sizes are selected. The floor plans of buildings are shown in Figure 6.3. Also structural modelling configuration used for modelling is demonstrated in Table 6.1.

. Table 6.1. Model structural configurations.

Element	Description
Slab	Reinforced concrete deck
Beams	Structural steel beam sections
Column	Structural column sections
Core Wall	Concrete wall
Outriggers and Belt Trusses	Structural steel cross sections

In addition to conventional belt-trussed system two more different kind of belt-trussed systems are examined in this study. These systems' floor cut views are demonstrated in Figure 6.9 and Figure 6.10.

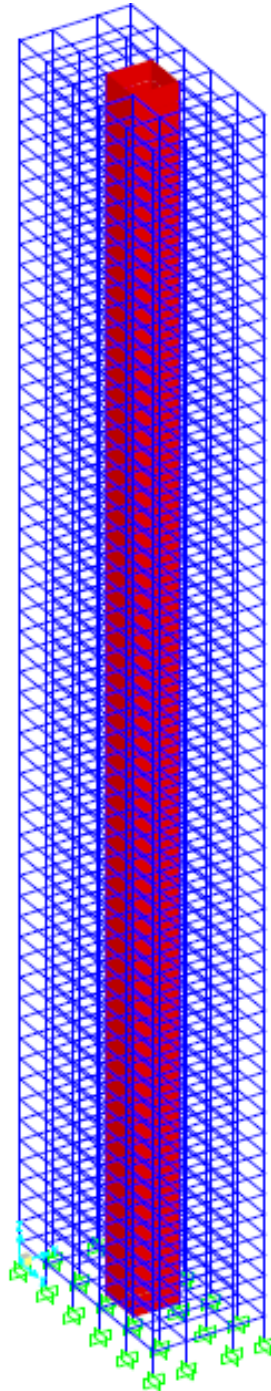

Figure 6.1. 3D view of sixty-floor building model without belt-trussed frame system.

Beams are connecting the core and at some points connecting to outer and inner columns. Inner outrigger trusses are connecting columns and core system. Belt trusses are connecting outer columns. All columns and beams are orthogonal to principal axis of buildings. The buildings have rectangular geometry shape. This shape is exposed to wind loading directly. Wind loads are proportional to the vertical projected areas of the building normal to the wind flow.

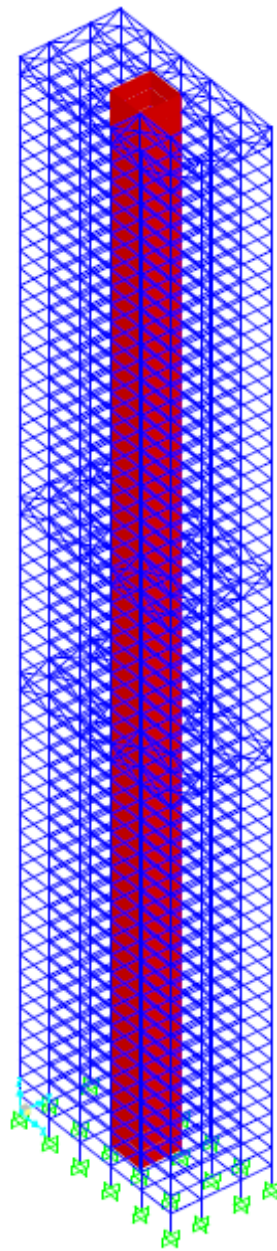

Figure 6.2. 3D view of sixty-floor building model with belt-trussed frame system.

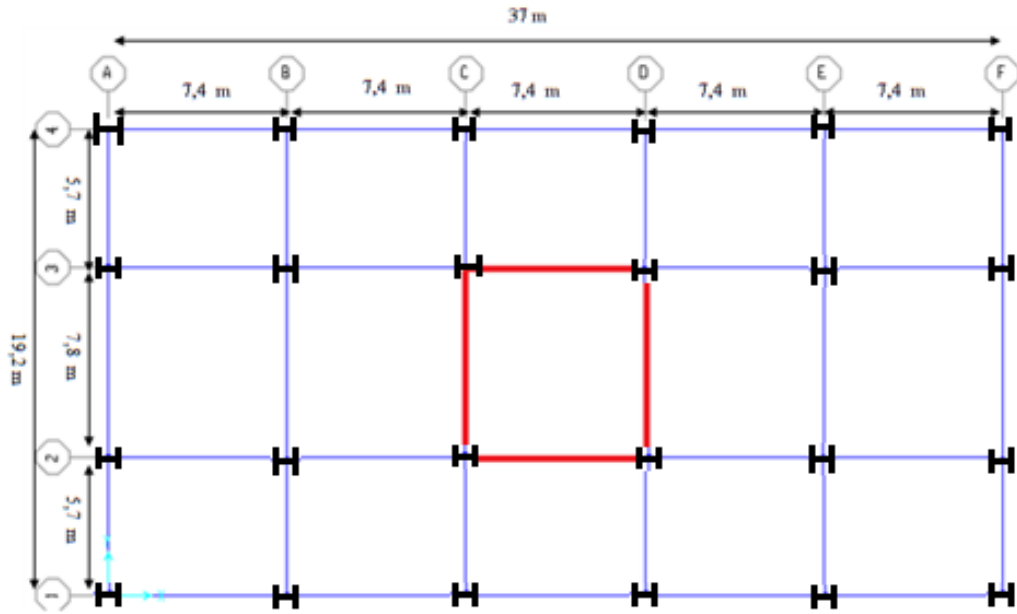

Figure 6.3. Typical floor plan of the building.

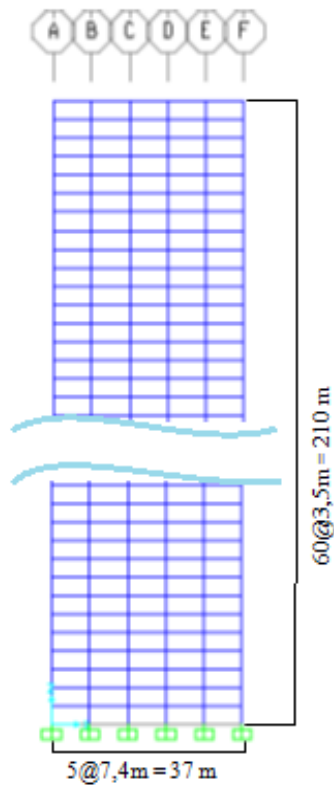

Figure 6.4. 1 and 4 axis view of sixty-floor building without belt-trussed frame system.

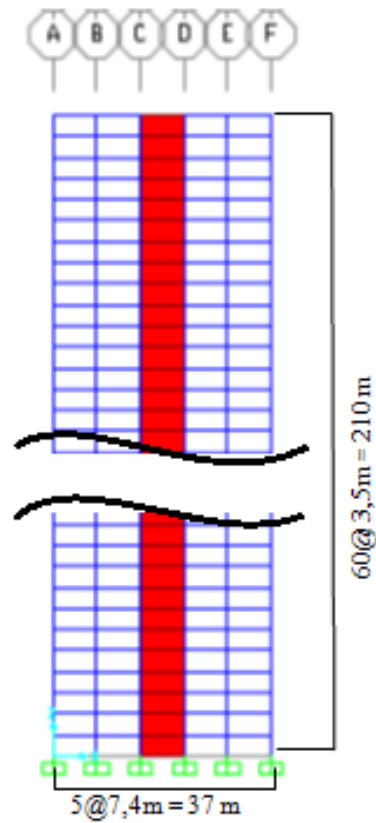

Figure 6.5. 2 and 3 axis view of sixty- floor building without belt-trussed frame system.

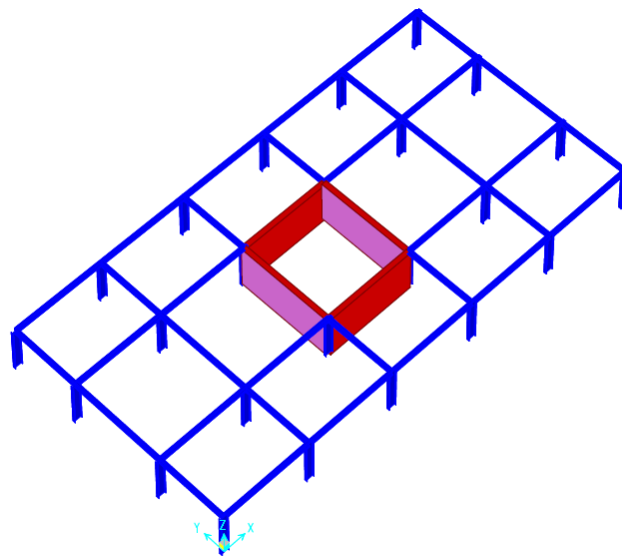

Figure 6.6. 3D view of single story.

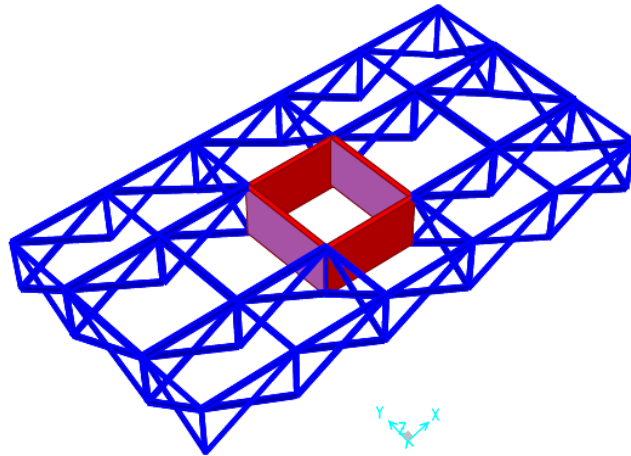

Figure 6.7. 3D view of conventional outrigger and belt truss.

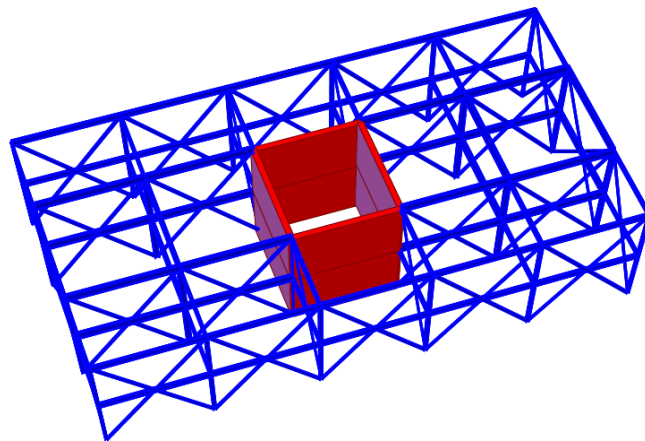

Figure 6.8. 3D view of deep outrigger and belt truss.

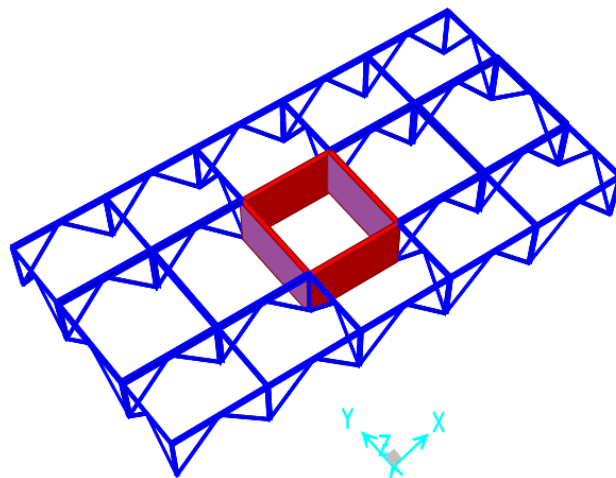

Figure 6.9. 3D view of inverted v outrigger and belt truss.

Construction material used for the members is steel and core system is made of reinforced concrete. Steel type is A572 and its grade is 50. Minimum yield stress is $F_y = 448 \text{ N/mm}^2$. The profile sections of beams are I-shape and all columns are H-shape. By means of using steel elements, rentable area quantity increases. Moreover, steel beams and columns have very thin cross-sections when compared to concrete elements. In addition, weight of steel structural elements per unit volume is lower than concrete elements.

In this study, considered loads acting on the examined buildings are dead, live, wind and earthquake loads. Loading procedures of these loads and their parameters are defined one by one below. All these definitions are specified according to the provisions of ASCE7-10 and Turkish Earthquake Code 2007.

7. LOADS ACTING ON THE BUILDINGS

7.1. Dead and Live Loads

Floor system of buildings is composite deck with lightweight concrete on steel deck. A uniform weight of 2.2 kN/m^2 . The weight of structural members (columns, beams etc.) is considered as dead load. The other items such as weight of cladding, stairways, fixed service equipments are ignored.

Minimum uniformly distributed live load required by office type occupancy in ASCE7-10 is 2.4 kN/m^2 and in this study this amount of live load is applied on buildings. The minimum uniformly distributed live loads, L_o , may be reduced by the reduction factor. In this study reduction of live load is ignored.

7.1.1. Distribution of Dead and Live Loads

Dead load and live load acting on building are distributed on beams. The distribution of these loads on members depends on the location of members and tributary area. The distribution of load to a floor beam depends on the geometric configuration of the beams forming the grid. In our buildings, the slabs of floor plan have one specific geometrical shape which is rectangular. These slabs are supported on a rectangular grid. The area of slab that is supported by a particular beam is termed the beam's tributary area. The tributary area for both an interior and an exterior beams are shown in Figure 7.1.

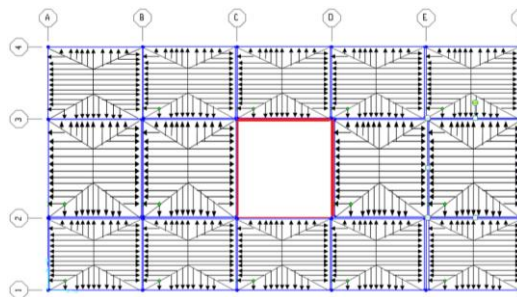

Figure 7.1. Tributary areas of interior and exterior beams.

The beams are named to make them recognizable easily. This specific name has a code which starts with "B" and number follows this letter. The names of beams are shown in Figure 7.2. The beams, corresponding values of distributed loads and load distribution style (trapezoid, triangular) are also presented in Table 7.1. In the figure half of floor plan is shown. The other beams which are located on the other half of floor plan have same values and distribution style.

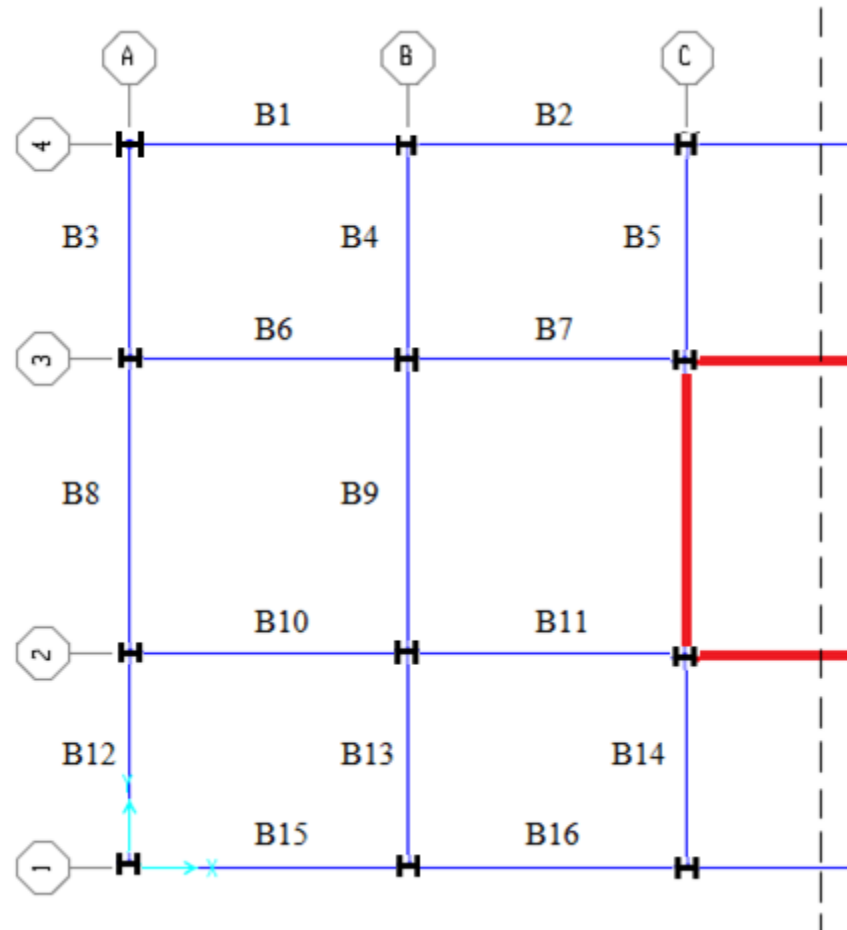

Figure 7.2. Given specific codes of beams.

Table 7.1. Distributed loads on beams and load distribution style.

Beam No	Distributed Dead Load (kN/m)	Distributed Live Load (kN/m)	Distribution Style
B1	6.27	6.84	Trapezoid
B2	6.27	6.84	Trapezoid
B3	6.27	6.84	Triangular
B4	6.27	6.84	Triangular
	6.27	6.84	Triangular
B5	6.27	6.84	Triangular
	6.27	6.84	Triangular
B6	6.27	6.84	Trapezoid
	8.14	8.88	Triangular
B7	6.27	6.84	Trapezoid
	8.14	8.88	Triangular
B8	8.14	8.88	Trapezoid
B9	8.14	8.88	Trapezoid
	8.14	8.88	Trapezoid
B10	6.27	6.84	Trapezoid
	8.14	8.88	Triangular
B11	6.27	6.84	Trapezoid
	8.14	8.88	Triangular
B12	6.27	6.84	Triangular
B13	6.27	6.84	Triangular
	6.84	6.84	Triangular
B14	6.27	6.84	Triangular
	6.27	6.84	Triangular
B15	6.27	6.84	Trapezoid
B16	6.27	6.84	Trapezoid

7.2. Wind Loads

In ASCE7-10 wind loads are determined from basic wind speed maps of U.S.A. Since there is no any design wind speed map particular for Turkey, design wind speed is obtained from a study (Tek *et al.*, 1993) containing statistical analysis of wind speed data in large cities of Turkey. These cities are Istanbul, Izmir and Ankara. This statistical study was prepared in Meteorology Laboratory of Boğaziçi University Kandilli Observatory and Earthquake Research Institute. Hundred-year and fifty-year return period design wind

speeds were obtained for some specific towns of these cities. These obtained speeds are shown in different tables in this study.

Table 7.2. 50-year return period design wind speed for Istanbul (Tek *et al.*, 1993).

	%68 Confidence	%95 Confidence	%99 Confidence
Region	V (m/s)	V (m/s)	V (m/s)
Göztepe	29.74 ± 1.94	29.74 ± 3.88	29.74 ± 5.82
Kartal	25.51 ± 2.62	25.51 ± 5.24	25.51 ± 7.86
Florya	30.34 ± 1.77	30.34 ± 3.54	30.34 ± 5.31
Kumköy	39.05 ± 3.20	39.05 ± 6.40	39.05 ± 9.60
Sarıyer	31.64 ± 1.83	31.64 ± 3.66	31.64 ± 5.49
Bahçeköy	21.37 ± 2.14	21.37 ± 4.28	21.37 ± 6.42
Şile	42.26 ± 3.73	42.26 ± 7.46	42.26 ± 11.19
Silivri	23.84 ± 1.68	23.84 ± 3.36	23.84 ± 5.04
Yalova	26.31 ± 1.77	26.31 ± 3.54	26.31 ± 5.31

Table 7.3. 100-year return period design wind speed for Istanbul (Tek *et al.*, 1993).

	%68 Confidence	%95 Confidence	%99 Confidence
Region	V (m/s)	V (m/s)	V (m/s)
Göztepe	31.42 ± 2.41	31.42 ± 4.82	31.42 ± 7.23
Kartal	27.17 ± 3.11	27.17 ± 6.22	27.17 ± 9.33
Florya	31.75 ± 2.18	31.75 ± 4.36	31.75 ± 6.54
Kumköy	41.30 ± 3.85	41.30 ± 7.70	41.30 ± 11.55
Sarıyer	32.93 ± 2.20	32.93 ± 4.40	32.93 ± 6.60
Bahçeköy	22.96 ± 2.60	22.96 ± 5.20	22.96 ± 7.80
Şile	44.79 ± 4.47	44.79 ± 8.94	44.79 ± 13.41
Silivri	24.91 ± 1.99	24.91 ± 3.98	24.91 ± 5.97
Yalova	28.63 ± 2.09	28.63 ± 4.18	28.63 ± 6.27

In ASCE7-10 regional climatic data are only be used in lieu of the basic wind speeds. These wind speeds are given in basic wind speed maps when approved extreme-value statistical-analysis procedures have been used in reducing the data; and the length of record, averaging time, anemometer height, data quality, sampling error and terrain exposure of anemometer have been taken into account.

In this study the buildings examined and analyzed are assumed to be in Istanbul, Göztepe. 50-year return period design wind speed with ninety five percent confidence degree is used for forty and sixty story buildings. These buildings are designed as office type building. From the tables are given above chosen design wind speed results in 29.74 m/sn. Exposure categories are determined by checking the location of structures. In this study exposure B is assumed proper for the district of Göztepe. Exposure B comprises urban areas, suburban areas, wooded areas and other terrain with numerous closely spaced obstructions having the size of family dwellings. Use of this exposure category shall be limited to those areas for which terrain representative of Exposure B prevails in the prevails upwind direction for a distance of at least 457 m or 10 times the height of building or other structure, whichever is larger. Our buildings heights are 140 m and 210 m for 40-story and 60-story building respectively. Parameters of Exposure B, C and D are demonstrated in Table 7.4.

Table 7.4. Parameters of exposure B, C and D (ASCE7-10).

Exposure	α	z_g (m)	$\hat{\alpha}$	\hat{b}	$\bar{\alpha}$	\bar{b}	c	ℓ (m)	$\bar{\epsilon}$	z_{min} (m)
B	7.0	365.76	1/7	0.84	1/4.0	0.45	0.30	97.54	1/3.0	9.14
C	9.5	274.32	1/9.5	1.00	1/6.5	0.65	0.20	152.4	1/5.0	4.57
D	11.5	213.36	1/11.5	1.07	1/9.0	0.80	0.15	198.12	1/8.0	2.13

Wind loads acting on the building surface are separated into two groups. These groups are windward and leeward wind loads. On windward side of building the wind flow applies a positive pressure, namely compression force. On leeward side of the building the wind flow applies a negative wind pressure, namely suction force. After determination of design wind speed at 10 m above the ground, wind speeds at each story diaphragm level are calculated by making use of power law. The power law provides to determine the boundary layer wind velocity profile. Wind pressure, which are proportional to the square of the wind velocity, determined at each story diaphragm (tributary area of the building is calculated by multiplying height of the story with the dimension of the story normal to the wind flow) story forces due to wind are obtained as equivalent static loads.

There are four cases of wind loading in ASCE7-10 for buildings including; Full wind loads in two perpendicular directions considered separately, 75% wind loads in two perpendicular directions simultaneously, 75% wind loads in two perpendicular directions with 15% eccentricity considered separately, 56.3% of wind load in two perpendicular directions with 15% eccentricity simultaneously. These loading cases are demonstrated in the following figures.

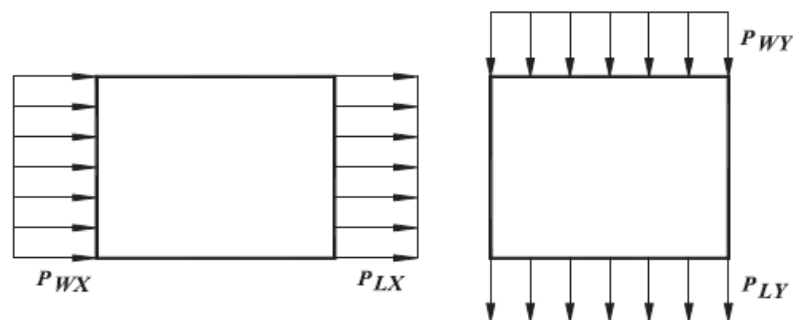

Figure 7.3. Full wind loads in two perpendicular directions considered separately.

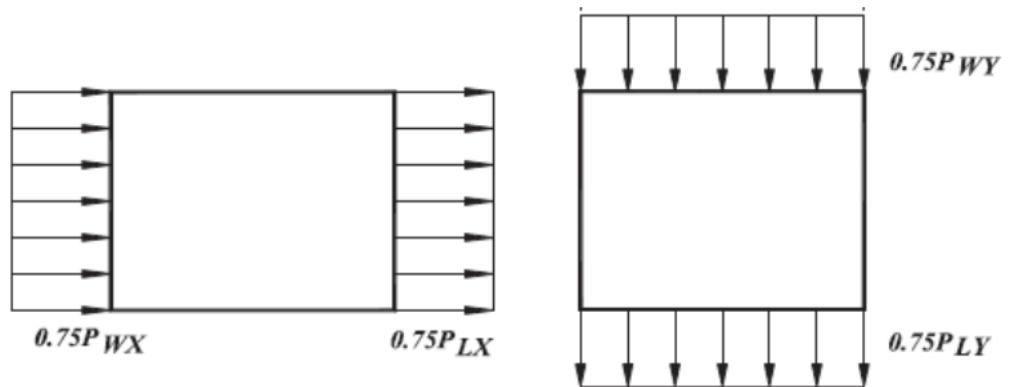

Figure 7.4. 75% wind loads in two perpendicular directions with 15% eccentricity considered separately.

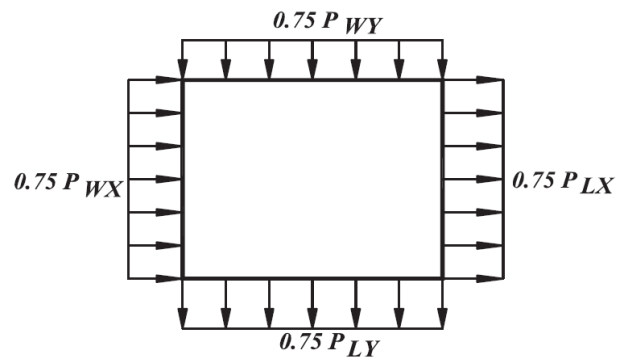

Figure 7.5. 75% wind loads in two perpendicular directions simultaneously.

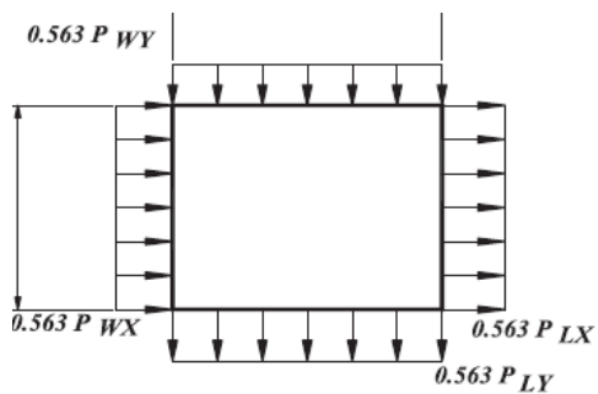

Figure 7.6. 56.3% of wind load in two perpendicular directions with 15% eccentricity simultaneously.

In these cases which are shown above the symbol P_W denotes the positive wind pressure acting on the windward side and P_L denotes negative wind pressure on leeward side on plan view of the building. According to provisions about wind load in ASCE7-10, wind forces acting on 60 story building are calculated. The value of P_L which is $-315,5 \text{ N/m}^2$ for sixty floor building acting is same on each floor level in x direction. This value is not demonstrated in table 7.5.

Table 7.5. Wind loads in x direction.

Story No	z(m)	K_z	q_z (lb/ft ²)	q_z (N/m ²)	P_W (N/m ²)	F_{wind} (kN)
1	3.5	0.532	5.11	244.9	166.5	32.4
2	7	0.649	6.23	298.5	203.0	34.8
3	10.5	0.729	7.00	335.2	227.9	36.5
4	14	0.791	7.60	363.9	247.4	37.8
5	17.5	0.843	8.10	387.8	263.7	38.9
6	21	0.888	8.53	408.6	277.8	39.9
7	24.5	0.928	8.92	427.0	290.3	40.7
8	28	0.965	9.26	443.6	301.6	41.5
9	31.5	0.998	9.58	458.8	312.0	42.2
10	35	1.028	9.87	472.8	321.5	42.8
11	38.5	1.056	10.15	485.8	330.4	43.4
12	42	1.083	10.40	498.1	338.7	44.0
13	45.5	1.108	10.64	509.6	346.5	44.5
14	49	1.132	10.87	520.5	353.9	45.0
15	52.5	1.154	11.09	530.8	361.0	45.5
16	56	1.176	11.29	540.7	367.7	45.9
17	59.5	1.196	11.49	550.2	374.1	46.3
18	63	1.216	11.68	559.2	380.3	46.8
19	66.5	1.235	11.86	567.9	386.2	47.2
20	70	1.253	12.04	576.3	391.9	47.5
21	73.5	1.271	12.21	584.4	397.4	47.9
22	77	1.288	12.37	592.2	402.7	48.3
23	80.5	1.304	12.53	599.8	407.9	48.6
24	84	1.320	12.68	607.1	412.8	48.9
25	87.5	1.336	12.83	614.3	417.7	49.3
26	91	1.351	12.97	621.2	422.4	49.6
27	94.5	1.365	13.11	627.9	427.0	49.9
28	98	1.380	13.25	634.5	431.4	50.2
29	101.5	1.394	13.38	640.9	435.8	50.5
30	105	1.407	13.51	647.1	440.0	50.8
31	108.5	1.420	13.64	653.2	444.2	51.1
32	112	1.433	13.77	659.1	448.2	51.3
33	115.5	1.446	13.89	665.0	452.2	51.6

Table 7.5. Wind loads in x direction (Continued)

34	119	1.458	14.01	670.7	456.0	51.9
35	122.5	1.470	14.12	676.2	459.8	52.1
36	126	1.482	14.24	681.7	463.6	52.4
37	129.5	1.494	14.35	687.1	467.2	52.6
38	133	1.505	14.46	692.3	470.8	52.8
39	136.5	1.517	14.57	697.5	474.3	53.1
40	140	1.528	14.67	702.5	477.7	53.3
41	143.5	1.539	14.78	707.5	481.1	53.5
42	147	1.549	14.88	712.4	484.4	53.8
43	150.5	1.560	14.98	717.2	487.7	54.0
44	154	1.570	15.08	721.9	490.9	54.2
45	157.5	1.580	15.17	726.6	494.1	54.4
46	161	1.590	15.27	731.2	497.2	54.6
47	164.5	1.600	15.36	735.7	500.3	54.8
48	168	1.609	15.46	740.1	503.3	55.0
49	171.5	1.619	15.55	744.5	506.2	55.2
50	175	1.628	15.64	748.8	509.2	55.4
51	178.5	1.637	15.73	753.0	512.1	55.6
52	182	1.647	15.81	757.2	514.9	55.8
53	185.5	1.656	15.90	761.4	517.7	56.0
54	189	1.664	15.99	765.4	520.5	56.2
55	192.5	1.673	16.07	769.5	523.2	56.4
56	196	1.682	16.15	773.4	525.9	56.5
57	199.5	1.690	16.24	777.3	528.6	56.7
58	203	1.699	16.32	781.2	531.2	56.9
59	206.5	1.707	16.40	785.0	533.8	57.1
60	210	1.715	16.47	788.8	536.4	57.2
					Σ	2969.0

In table 7.5, wind loads at each story level are shown. K_z is the velocity exposure pressure coefficient evaluated at z (in meters), q_z is the velocity pressure evaluated at height z . P_W and P_L indicate the pressures acting on windward and leeward faces of the building. When the wind flow is in x direction, across wind dimension of the building is the dimension normal to x direction and it is 19.2 m. The story wind force at story (F_{wind}) is obtained by the multiplication of wind pressures at that story by vertical projected area of a story which is $19.2 \text{ m} \times 3.5 \text{ m} = 67.2 \text{ m}^2$ normal to x direction is obtained by multiplying the across wind dimension (19.2 m) with the height of that story (3.5 m).

In the structural model of the building, the wind loads at each story level are applied to the columns as distributed load. All negative and positive wind loads acting on building surface are distributed to columns by multiplying the horizontal distance of tributary area. When the wind flow is in x direction, the value of P_W for first floor (166.5 N/m^2) is multiplied the horizontal distance of tributary area (5.7 m) for obtainment of distributed load on this affected column. In case the location of column is between two different tributary areas, distributed load is applied to column two times. All distributed windward wind loads acting on columns in x direction are shown in Table 7.6.

Table 7.6. Distributed windward loads in x direction.

Story No	1.Tributary Area		2.Tributary Area		3.Tributary Area	
	5.7 m		7.8 m		5.7 m	
	$P_{WR}(kN/m)$	$P_{WL}(kN/m)$	$P_{WR}(kN/m)$	$P_{WL}(kN/m)$	$P_{WR}(kN/m)$	$P_{WL}(kN/m)$
1	0.47	0.47	0.65	0.65	0.47	0.47
2	0.58	0.58	0.79	0.79	0.58	0.58
3	0.65	0.65	0.89	0.89	0.65	0.65
4	0.71	0.71	0.97	0.97	0.71	0.71
5	0.75	0.75	1.03	1.03	0.75	0.75
6	0.79	0.79	1.08	1.08	0.79	0.79
7	0.83	0.83	1.13	1.13	0.83	0.83
8	0.86	0.86	1.18	1.18	0.86	0.86
9	0.89	0.89	1.22	1.22	0.89	0.89
10	0.92	0.92	1.25	1.25	0.92	0.92
11	0.94	0.94	1.29	1.29	0.94	0.94
12	0.97	0.97	1.32	1.32	0.97	0.97
13	0.99	0.99	1.35	1.35	0.99	0.99
14	1.01	1.01	1.38	1.38	1.01	1.01
15	1.03	1.03	1.41	1.41	1.03	1.03
16	1.05	1.05	1.43	1.43	1.05	1.05
17	1.07	1.07	1.46	1.46	1.07	1.07
18	1.08	1.08	1.48	1.48	1.08	1.08
19	1.10	1.10	1.51	1.51	1.10	1.10
20	1.12	1.12	1.53	1.53	1.12	1.12
21	1.13	1.13	1.55	1.55	1.13	1.13
22	1.15	1.15	1.57	1.57	1.15	1.15
23	1.16	1.16	1.59	1.59	1.16	1.16
24	1.18	1.18	1.61	1.61	1.18	1.18
25	1.19	1.19	1.63	1.63	1.19	1.19
26	1.20	1.20	1.65	1.65	1.20	1.20
27	1.22	1.22	1.67	1.67	1.22	1.22

Table 7.6. Distributed windward loads in x direction (Continued)

28	1.23	1.23	1.68	1.68	1.23	1.23
29	1.24	1.24	1.70	1.70	1.24	1.24
30	1.25	1.25	1.72	1.72	1.25	1.25
31	1.27	1.27	1.73	1.73	1.27	1.27
32	1.28	1.28	1.75	1.75	1.28	1.28
33	1.29	1.29	1.76	1.76	1.29	1.29
34	1.30	1.30	1.78	1.78	1.30	1.30
35	1.31	1.31	1.79	1.79	1.31	1.31
36	1.32	1.32	1.81	1.81	1.32	1.32
37	1.33	1.33	1.82	1.82	1.33	1.33
38	1.34	1.34	1.84	1.84	1.34	1.34
39	1.35	1.35	1.85	1.85	1.35	1.35
40	1.36	1.36	1.86	1.86	1.36	1.36
41	1.37	1.37	1.88	1.88	1.37	1.37
42	1.38	1.38	1.89	1.89	1.38	1.38
43	1.39	1.39	1.90	1.90	1.39	1.39
44	1.40	1.40	1.91	1.91	1.40	1.40
45	1.41	1.41	1.93	1.93	1.41	1.41
46	1.42	1.42	1.94	1.94	1.42	1.42
47	1.43	1.43	1.95	1.95	1.43	1.43
48	1.43	1.43	1.96	1.96	1.43	1.43
49	1.44	1.44	1.97	1.97	1.44	1.44
50	1.45	1.45	1.99	1.99	1.45	1.45
51	1.46	1.46	2.00	2.00	1.46	1.46
52	1.47	1.47	2.01	2.01	1.47	1.47
53	1.48	1.48	2.02	2.02	1.48	1.48
54	1.48	1.48	2.03	2.03	1.48	1.48
55	1.49	1.49	2.04	2.04	1.49	1.49
56	1.50	1.50	2.05	2.05	1.50	1.50
57	1.51	1.51	2.06	2.06	1.51	1.51
58	1.51	1.51	2.07	2.07	1.51	1.51
59	1.52	1.52	2.08	2.08	1.52	1.52
60	1.53	1.53	2.09	2.09	1.53	1.53

P_{WR} denotes the pressure acting on the column located on the right side of tributary area. By using same logic, the meaning of P_{WL} is concluded as the pressure acting on the column located on the left side of tributary area. Same technique of distributing load is followed for negative wind pressure load. This time horizontal distances stay same but acting loads on tributary area change. Leeward loads are shown with minus mathematical symbol which means these loads are acting as suction load. All distributed leeward wind loads on columns in x direction are shown in Table 7.7.

Table 7.7. Distributed leeward loads in x direction.

Story No	1.Tributary Area		2.Tributary Area		3.Tributary Area	
	5.7 m		7.8 m		5.7 m	
	$P_{LR}(kN/m)$	$P_{LL}(kN/m)$	$P_{LR}(kN/m)$	$P_{LL}(kN/m)$	$P_{LR}(kN/m)$	$P_{LL}(kN/m)$
1 - 60	-0.90	-0.90	-1.23	-1.23	-0.90	-0.90

In Table 7.8, wind loads at each story level are shown. K_z is the velocity exposure pressure coefficient evaluated at z (in meters), q_z is the velocity pressure evaluated at height z . P_W and P_L indicate the pressures acting on windward and leeward faces of the building. When the wind flow is in y direction, across wind dimension of the building is the dimension normal to y direction and it is 37 m. The story wind force at story (F_{wind}) is obtained by the multiplication of wind pressures at that story by vertical projected area of a story which is $37 \text{ m} * 3.5 \text{ m} = 129.5 \text{ m}^2$ normal to y direction is obtained by multiplying the across wind dimension (37 m) with the height of that story (3.5 m). The value of P_L which is -191.8 N/m^2 for sixty floor building acting is same on each floor level in y direction. This value is not demonstrated in table 7.8.

Table 7.8. Wind loads in y direction.

Story No	$z(\text{m})$	K_z	$q_z(\text{lb/ft}^2)$	$q_z(\text{N/m}^2)$	$P_W(\text{N/m}^2)$	$F_{wind}(\text{kN})$
1	3.5	0.532	5.11	244.9	166.5	46.4
2	7	0.649	6.23	298.5	203.0	51.1
3	10.5	0.729	7.00	335.2	227.9	54.4
4	14	0.791	7.60	363.9	247.4	56.9
5	17.5	0.843	8.10	387.8	263.7	59.0
6	21	0.888	8.53	408.6	277.8	60.8
7	24.5	0.928	8.92	427.0	290.3	62.4
8	28	0.965	9.26	443.6	301.6	63.9
9	31.5	0.998	9.58	458.8	312.0	65.2
10	35	1.028	9.87	472.8	321.5	66.5
11	38.5	1.056	10.15	485.8	330.4	67.6
12	42	1.083	10.40	498.1	338.7	68.7
13	45.5	1.108	10.64	509.6	346.5	69.7
14	49	1.132	10.87	520.5	353.9	70.7
15	52.5	1.154	11.09	530.8	361.0	71.6
16	56	1.176	11.29	540.7	367.7	72.5

Table 7.8. Wind loads in y direction (Continued)

17	59.5	1.196	11.49	550.2	374.1	73.3
18	63	1.216	11.68	559.2	380.3	74.1
19	66.5	1.235	11.86	567.9	386.2	74.9
20	70	1.253	12.04	576.3	391.9	75.6
21	73.5	1.271	12.21	584.4	397.4	76.3
22	77	1.288	12.37	592.2	402.7	77.0
23	80.5	1.304	12.53	599.8	407.9	77.7
24	84	1.320	12.68	607.1	412.8	78.3
25	87.5	1.336	12.83	614.3	417.7	78.9
26	91	1.351	12.97	621.2	422.4	79.5
27	94.5	1.365	13.11	627.9	427.0	80.1
28	98	1.380	13.25	634.5	431.4	80.7
29	101.5	1.394	13.38	640.9	435.8	81.3
30	105	1.407	13.51	647.1	440.0	81.8
31	108.5	1.420	13.64	653.2	444.2	82.4
32	112	1.433	13.77	659.1	448.2	82.9
33	115.5	1.446	13.89	665.0	452.2	83.4
34	119	1.458	14.01	670.7	456.0	83.9
35	122.5	1.470	14.12	676.2	459.8	84.4
36	126	1.482	14.24	681.7	463.6	84.9
37	129.5	1.494	14.35	687.1	467.2	85.3
38	133	1.505	14.46	692.3	470.8	85.8
39	136.5	1.517	14.57	697.5	474.3	86.3
40	140	1.528	14.67	702.5	477.7	86.7
41	143.5	1.539	14.78	707.5	481.1	87.1
42	147	1.549	14.88	712.4	484.4	87.6
43	150.5	1.560	14.98	717.2	487.7	88.0
44	154	1.570	15.08	721.9	490.9	88.4
45	157.5	1.580	15.17	726.6	494.1	88.8
46	161	1.590	15.27	731.2	497.2	89.2
47	164.5	1.600	15.36	735.7	500.3	89.6
48	168	1.609	15.46	740.1	503.3	90.0
49	171.5	1.619	15.55	744.5	506.2	90.4
50	175	1.628	15.64	748.8	509.2	90.8
51	178.5	1.637	15.73	753.0	512.1	91.2
52	182	1.647	15.81	757.2	514.9	91.5
53	185.5	1.656	15.90	761.4	517.7	91.9
54	189	1.664	15.99	765.4	520.5	92.2
55	192.5	1.673	16.07	769.5	523.2	92.6

Table 7.9. Distributed windward loads in y direction (Continued)

58	1.98	1.98	1.98	1.98	1.98	1.98	1.98	1.98	1.98	1.98
59	1.99	1.99	1.99	1.99	1.99	1.99	1.99	1.99	1.99	1.99
60	2.00	2.00	2.00	2.00	2.00	2.00	2.00	2.00	2.00	2.00

Table 7.10. Distributed leeward loads in y direction.

Story No	1.Tributary Area		2.Tributary Area		3.Tributary Area		4.Tributary Area		5.Tributary Area	
	7.4 m		7.4 m		7.4 m		7.4 m		7.4 m	
	P_{LR} (kN/m)	P_{LL} (kN/m)	P_{LR} (kN/m)	P_{LL} (kN/m)	P_{LR} (kN/m)	P_{LL} (kN/m)	P_{LR} (kN/m)	P_{LL} (kN/m)	P_{LR} (kN/m)	P_{LL} (kN/m)
1 - 60	-0.71	-0.71	-0.71	-0.71	-0.71	-0.71	-0.71	-0.71	-0.71	-0.71

7.3. Earthquake Loads

Earthquake loads on a structure basically due to property of structure itself and also seismic properties and soil type of the site where the structure built up. The forty-story and sixty story buildings steel buildings examined in this study are very flexible. When compared with conventional low-rise buildings these two buildings have long fundamental periods. For this reason, in general minimum base shear force as a percentage of the building weight given in the design codes conducts the design shear rather than the base shear determined from the seismic properties and the soil type of the ground for flexible buildings. In this study, buildings designed and analyzed are assumed to be constructed in Göztepe, Istanbul. Considering this assumption, soil and earthquake characteristics of the structural system are determined on the basis of the Turkish Earthquake Code 2007. The soil groups which are given in Turkish Earthquake Code 2007 are demonstrated in Table 7.11.

Table 7.11. Soil groups (TEC-2007).

<i>Soil Group</i>	<i>Description of Soil Group</i>	<i>Standard Penetration (N/30)</i>	<i>Relative Density (%)</i>	<i>Unconfined Compressive Strength (kPa)</i>	<i>Drift Wave Velocity (m/s)</i>
(A)	1. Massive volcanic rocks, unweathered sound metamorphic rocks, stiff cemented sedimentary rocks	-	-	> 1000	> 1000
	2. Very dense sand, gravel...	> 50	85 - 100	-	> 700
	3. Hard clay and silty clay...	> 32	-	> 400	> 700
(B)	1. Soft volcanic rocks such as tuff and agglomerate, weathered cemented sedimentary rocks with planes of discontinuity...	-	-	500 - 1000	700 - 1000
	2. Dense sand, gravel...	30 - 50	65 - 85	-	400 - 700
	3. Very stiff clay, silty clay...	16 - 32	-	200 - 400	300 - 700
(C)	1. Highly weathered soft metamorphic rocks and cemented sedimentary rocks with planes of discontinuity	-	-	< 500	400 - 700
	2. Medium dense sand and gravel.....	10 - 30	35 - 65	-	200 - 400
	3. Stiff clay and silty clay...	8 - 16	-	100 - 200	200 - 300
(D)	1. Soft, deep alluvial layers with high ground water level	-	-	-	< 200
	2. Loose sand...	< 10	< 35	-	< 200
	3. Soft clay and silty clay...	< 8	-	< 100	< 200

Based on the site soil properties, the soils shall be classified as soil groups A, B, C and D. In this study soil group of buildings is defined as B soil group which is very dense soil and soft volcanic rock.

In Turkish Earthquake Code 2007, the local site classes of buildings are determined by looking at the soil groups. Each region in Turkey belongs to one of site classes which are demonstrated in Table 7.12.

Table 7.12. Local site classes (TEC-2007)

<i>Local Site Class</i>	<i>Soil Group according to Table 7.11 and Topmost Soil Layer Thickness (h_l)</i>
Z1	Group (A) soils Group (B) soils with $h_l \leq 15$ m
Z2	Group (B) soils with $h_l > 15$ m Group (C) soils with $h_l \leq 15$ m
Z3	Group (C) soils with $15 \text{ m} < h_l \leq 50$ m Group (D) soils with $h_l \leq 10$ m
Z4	Group (C) soils with $h_l > 50$ m Group (D) soils with $h_l > 10$ m

In this study our buildings' site classes comply with the B local site class. To calculate design response spectrum for the buildings some parameters are required. Mainly these parameters are derived by determining T_A and T_B , spectrum characteristic periods of the local site classes. The spectrum characteristic periods are specified according to local site classes in Turkish Earthquake Code 2007.

Table 7.13. Spectrum characteristic periods.

Local Site Classes	T_A (second)	T_B (second)
Z1	0.10	0.30
Z2	0.15	0.40
Z3	0.15	0.60
Z4	0.20	0.90

For our buildings by using Table 7.13, T_A and T_B values are chosen as 0.15 and 0.40. Considering these spectrum characteristic periods $S(T)$, spectrum coefficient values are obtained for each period values by using Equation (7.1), Equation (7.2) and Equation (5.3).

$$S(T) = 1 + 1.5 \cdot \left(\frac{T}{T_A} \right) \quad (0 \leq T \leq T_A) \quad (7.1)$$

$$S(T) = 2.5 \quad (T_A \leq T \leq T_B) \quad (7.2)$$

$$S(T) = 2.5 \cdot \left(\frac{T_B}{T} \right)^{0.8} \quad (T_B \leq T) \quad (7.3)$$

For each unit second a spectrum coefficient value is obtained. Using these values a spectrum curve is calculated. The elastic acceleration spectrum curve for the building is

demonstrated in Figure 7.7. This figure is a schematic representation and it is not scaled. In horizontal axis, T denotes the period of building.

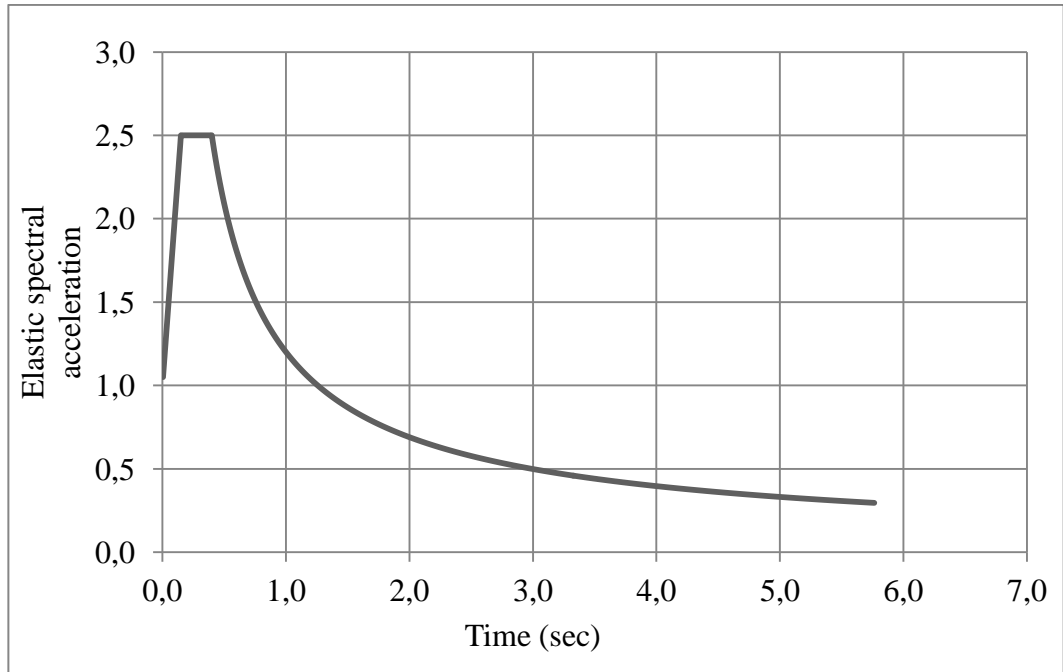

Figure 7.7. Elastic acceleration spectrum curve.

Structural system in both directions is composed of structural steel braced frames or cast-in-situ reinforced concrete structural walls. The value of structural system behavior factor for the building, R is 4. In order to consider the specific nonlinear behavior of the structural system during earthquake, elastic seismic loads to be determined in terms of spectral acceleration coefficient shall be divided to seismic load reduction factor R_a . Seismic load reduction factor is determined by Equation (7.5) and Equation (7.6) in terms of the natural vibration period T and structural system behavior factor.

$$R_a(T) = 1.5 + (R - 1.5) \frac{T}{T_A} \quad (0 \leq T \leq T_A) \quad (7.5)$$

$$R_a(T) = R \quad (T_B \leq T) \quad (7.6)$$

The effective ground acceleration coefficient, A_0 and the building importance factor, I are 0.4 and 1 respectively. These values are obtained from tables in Turkish Earthquake Code 2007.

The spectral acceleration coefficient, $A(T)$, which is considered as the basis for the determination of seismic loads is given by Equation (7.8). Elastic spectral acceleration, $S_{ae}(T)$ which is the ordinate of elastic acceleration spectrum defined for 5% damped rate is derived by multiplying spectral acceleration coefficient with gravity, g in Equation (7.9).

$$A(T) = A_0 \cdot I \cdot S(T) \quad (7.8)$$

$$S_{ae}(T) = A(T) \cdot g \quad (7.9)$$

Methods to be used for the seismic analysis of buildings and building-like structures are equivalent seismic load method, mode–superposition method and analysis methods in the time domain can be used for the seismic analysis of all buildings and building-like structures. In this study main method for calculation of seismic load, mode – superposition method is chosen. The use of equivalent seismic load method is limited to some rules which are related to height of buildings in Turkish Earthquake Code 2007 and analyzed buildings in this study are not proper for usage of equivalent seismic load method.

In mode – superposition method, maximum internal forces and displacements are determined by the statistical combination of maximum contributions obtained from each of the sufficient number of natural vibration modes considered. The elastic design acceleration spectrum $S_{ae}(T)$ values are determined according to each period (second), T values. Reduced acceleration spectrum ordinate to be taken into account in any n 'th vibration mode shall be determined by Equation (7.10). These values are defined and calculated by SAP2000 program.

$$S_{aR}(T_n) = \frac{S_{ae}(T_n)}{R_a(T_n)} \quad (7.10)$$

Thanks to SAP2000 program, linear and nonlinear analyses are eligible to use. In this study, in terms of analyzed building compliance, linear dynamic analysis is carried out. There are various linear analysis types and response-spectrum analysis is one of them. Response-Spectrum analysis which is statistical calculation of the response due to acceleration loads is chosen proper method for analysis procedure. This method needs response-spectrum functions. By using TEC2007, Response-Spectrum curve is obtained in this thesis. This curve is defined as functions to the SAP2000 program.

The dynamic equilibrium equations associated with the response of a structure to ground motion are given in Equation (7.11).

$$Ku(t) + C\dot{u}(t) + M\ddot{u}(t) = m_x \ddot{u}_{gx}(t) + m_y \ddot{u}_{gy}(t) + m_z \ddot{u}_{gz}(t) \quad (7.11)$$

where K is the stiffness matrix; C is the proportional damping matrix; M is the diagonal mass matrix; u , \dot{u} , and \ddot{u} are the relative displacements, velocities, and accelerations with respect to the ground; m_x , m_y , and m_z are the unit acceleration loads; and \ddot{u}_{gx} , \ddot{u}_{gy} , and \ddot{u}_{gz} are the components of uniform ground acceleration.

Response-spectrum analysis searches the potential maximum response to these equations rather than the full time history. The earth quake ground acceleration in each direction is given as a digitized response-spectrum curve of pseudo-spectral acceleration response versus period of the structure. Even though accelerations may be specified in three directions, only a single, positive result is produced for each response quantity. The response quantities include displacements, forces, and stresses. Each of computed results

depicts a statistical measure of the potential maximum magnitude for that response quantity. The actual response can be expected to change in a range from this positive value to its negative value.

There is not available correspondence between two different response quantities. Any information is available as to when this extreme value occurs during the seismic loading. Besides there is no available information as to what the values of other response quantities are at that time.

For a given direction of acceleration, the maximum displacements, forces, and stresses are computed throughout the structure for each of the vibration modes. These modal values for a given response quantity are combined to produce a single, positive result for the given direction of acceleration. In this study for modal combination CQC (Complete Quadratic Combination) system is chosen. The CQC method takes into account the statistical coupling between closely spaced modes caused by modal damping. Increasing the modal damping increases the coupling between closely-spaced modes. In the application of this method, modal factor shall be taken as 5% for all models.

8. COMPARISON OF ANALYSIS RESULT OF WIND AND EARTHQUAKE LOADINGS ON BUILDINGS

It is very essential to consider the effects of lateral loads induced from wind and earthquakes in the design of steel structures, especially for high-rise buildings. In some cases, effects of earthquakes are found to be dominant and more critical than wind effects. In this section, the effects of both loads applied on 60-story and 40-story buildings are compared. Comparisons help to find dominant load. According to results, sections of structural members such as column and beam are designed.

Table 8.1. Shear force and moment at the base of 60-story building due to wind and earthquake in x-direction.

	V_x (kN)	M_x (kN.m)
WIND	2969.68	651646.10
EARTHQUAKE	4315.89	274039.74

Table 8.2. Shear force and moment at the base of 60-story building due to wind and earthquake in y-direction.

	V_y (kN)	M_y (kN.m)
WIND	5821.2	333158.84
EARTHQUAKE	4388.71	275766.15

Table 8.3. Shear force and moment at the base of 40-story building due to wind and earthquake in x-direction.

	V_x (kN)	M_x (kN.m)
WIND	1860	271472.25
EARTHQUAKE	3501.81	125345.22

Table 8.4. Shear force and moment at the base of 40-story building due to wind and earthquake in y-direction.

	V_y (kN)	M_y (kN.m)
WIND	3654	138532.43
EARTHQUAKE	3574.33	126060.91

In Table 8.1 and Table 8.2 the values of share force and moment at the base of 60-story building due to wind and earthquake in both directions. In Table 8.3 and Table 8.4 the values of share force and moment at the base of 40 story building due to wind and earthquake in both directions. V_x denotes share force at base in x direction, M_x is wind moment at the base in x direction. For V_y and M_y , same definitions are valid in y direction. As it seen in Table 8.1 and Table 8.2 V_y values of wind is slightly higher than V_y values of earthquake for both analyzed buildings whereas V_x values of earthquake is higher than V_x values of wind. The wind load applied along the y direction creates higher shear force and moment values than earthquake load.

Figure 8.1 gives the comparison of shear forces at the base of 60-story and 40-story buildings due to wind and earthquake in direction y. Figure 8.2 gives the comparison of moment values at the base moments of 60-story and 40-story buildings due to wind and earthquake in direction y. In these figures, it is shown that the values of moments and shear forces change depending on the building height. The higher the building is, the bigger the values are in y direction.

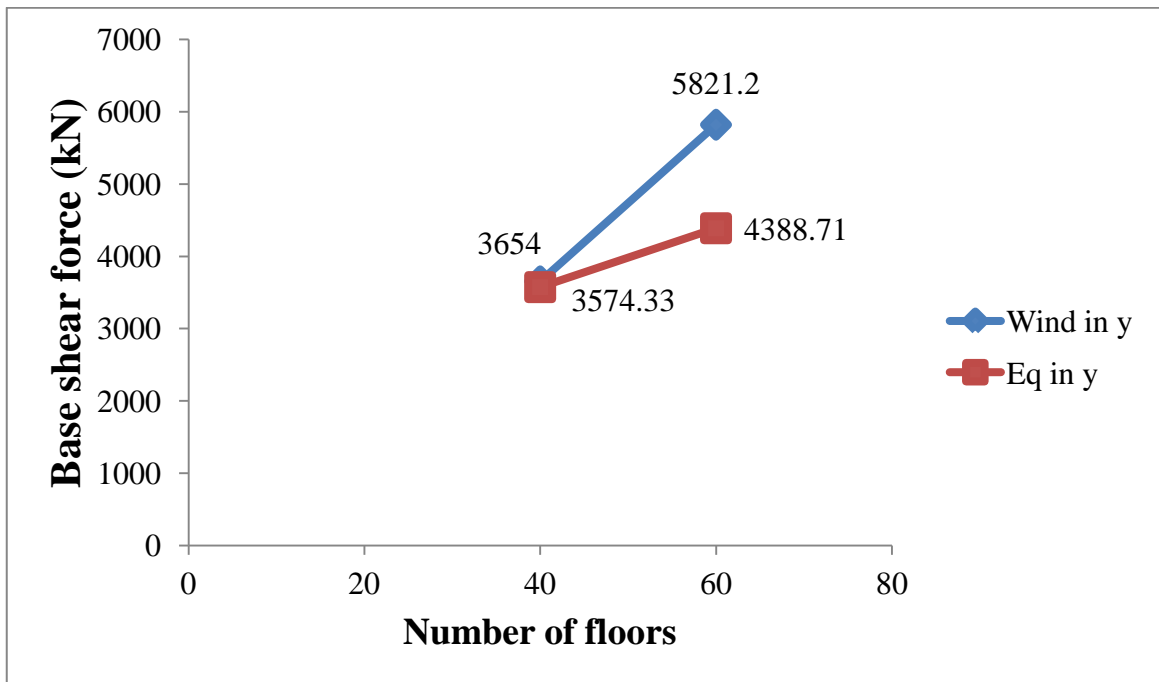

Figure 8.1. The comparison of shear forces at the base of 60-story and 40-story buildings in direction y.

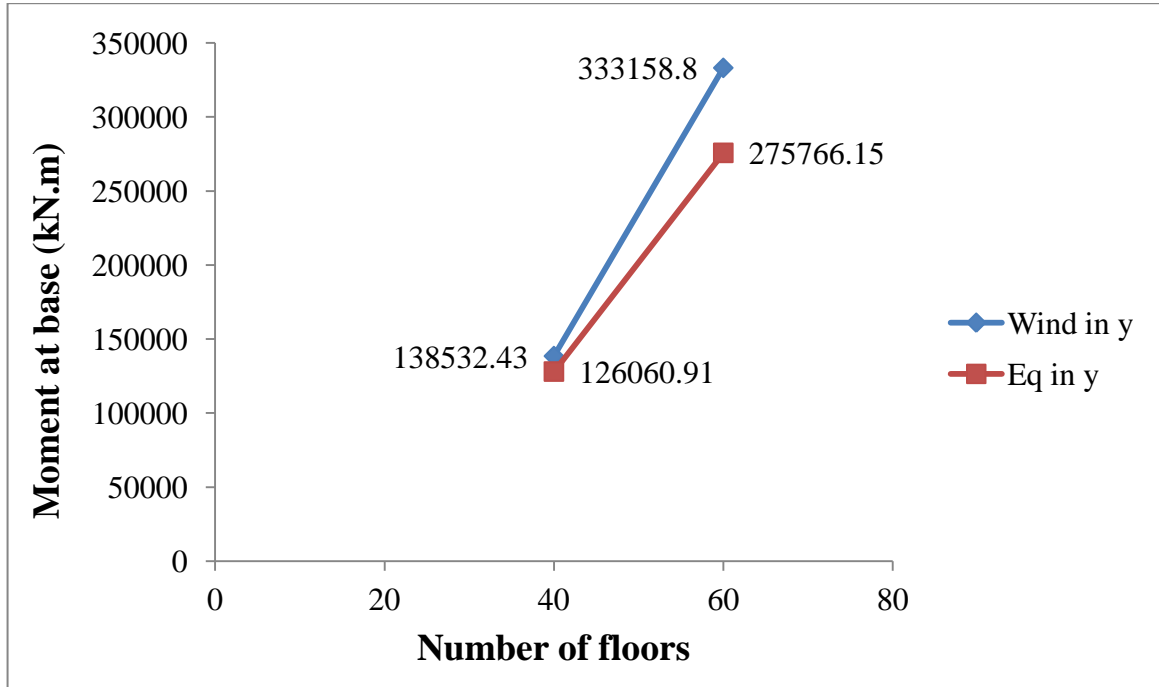

Figure 8.2. The comparison of moment values at the base moments of 60-story and 40-story buildings in y-direction.

Figure 8.3 and Figure 8.4 give the shear forces at each floor of buildings in kN due to wind and earthquake in direction y. Figure 8.5 and Figure 8.6 give the moments at each floor of buildings in kN due to wind and earthquake in direction y. Due to geometry of buildings analyzed, the loads applied along the y direction create major shear forces and moment values than x direction. Therefore, it gives more accurate results in comparison tables to demonstrate values in this direction.

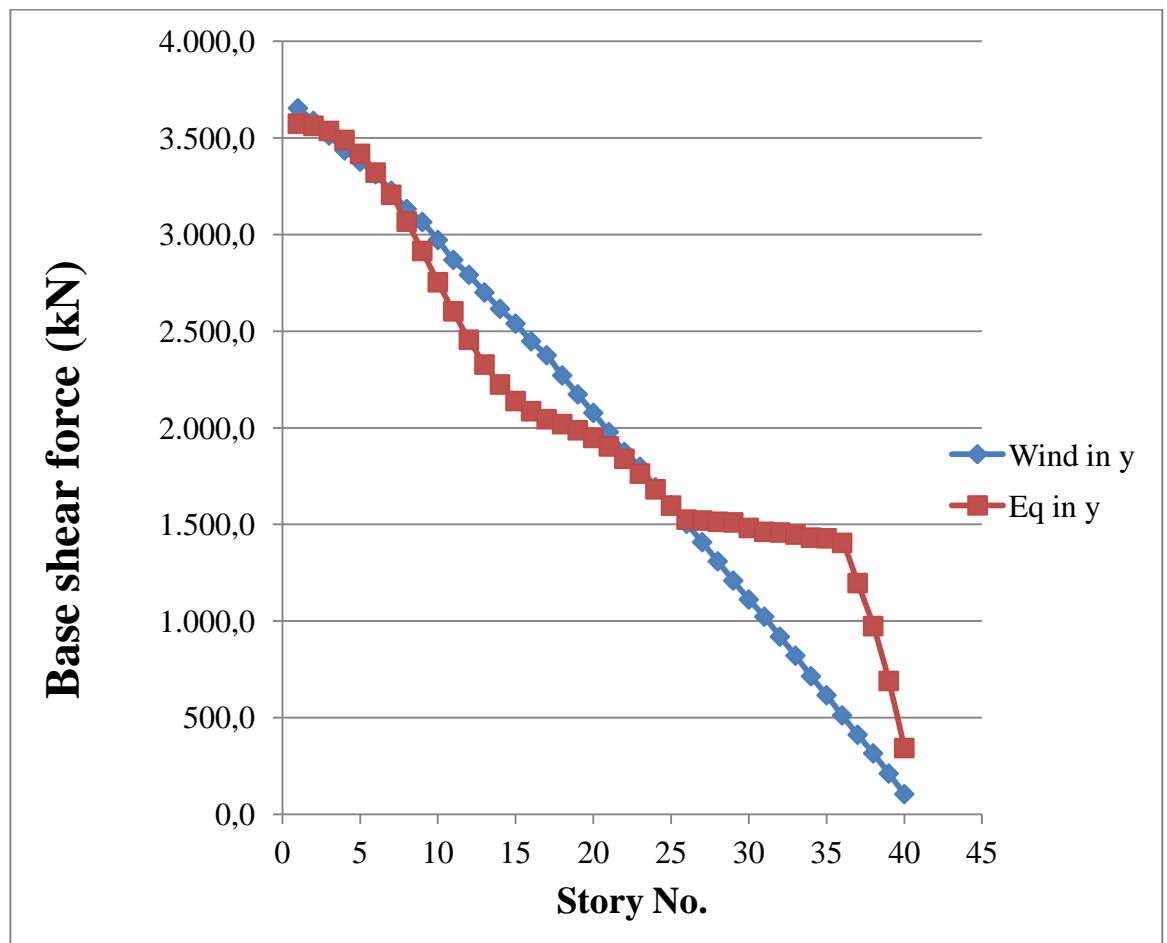

Figure 8.3. Shear forces at each floor of 40-story building in y-direction.

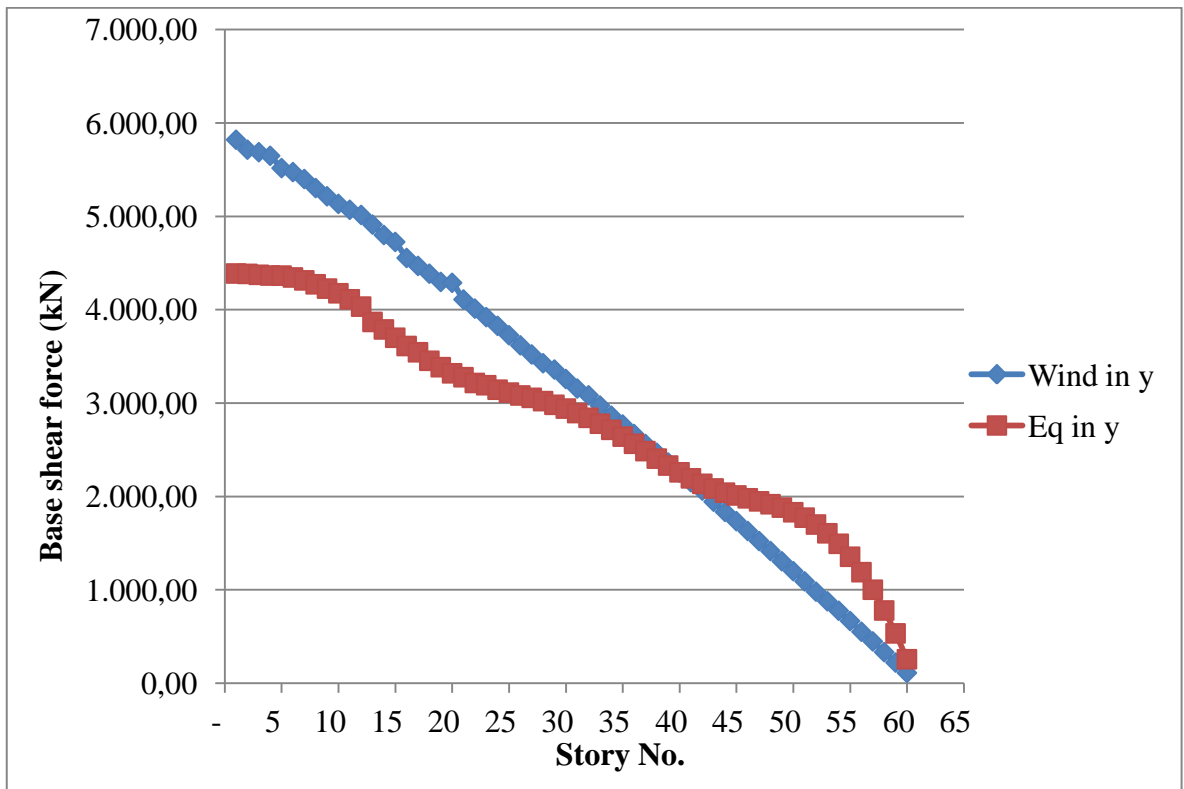

Figure 8.4. Shear forces at each floor of 60-story building in y-direction.

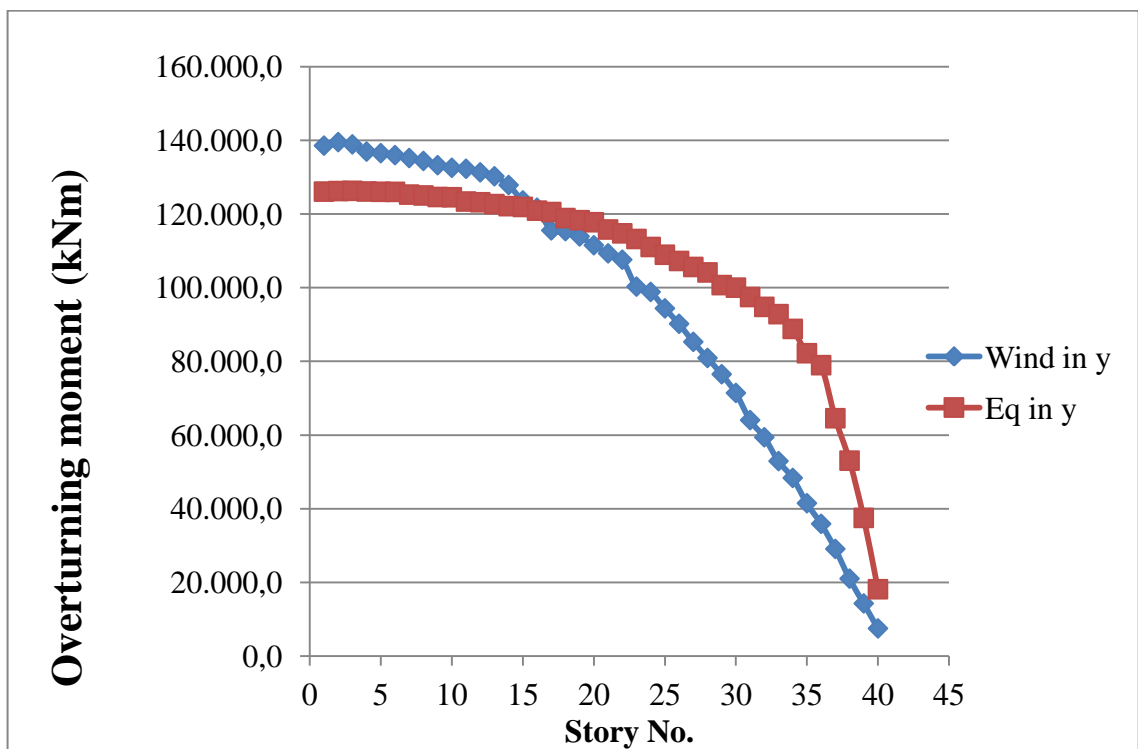

Figure 8.5. Overturning moment values at each floor of 40-story building in y-direction.

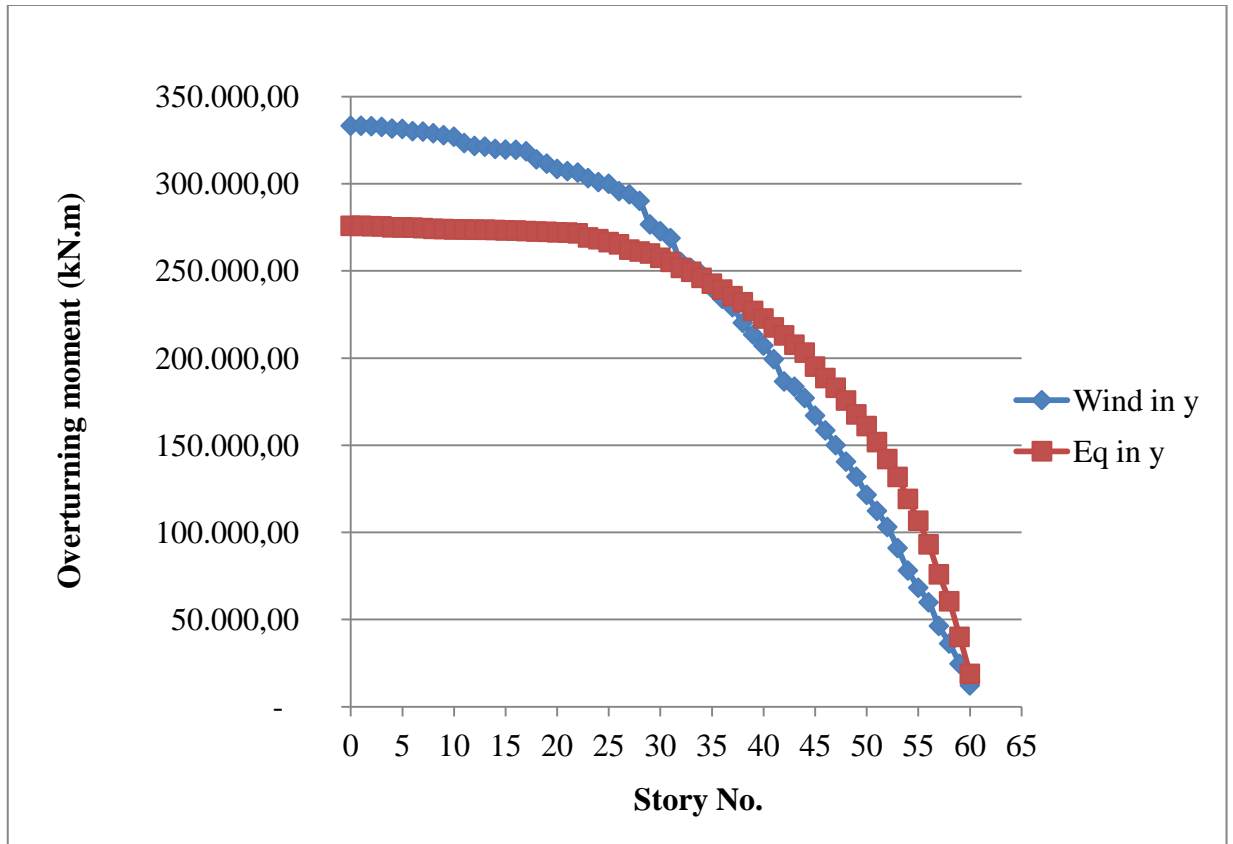

Figure 8.6. Overturning moment values at each floor of 60-story building in y-direction.

Table 8.5. Base shears and overturning moment of 60-story building in y-direction.

Story No.	Earthquake Loads in y Direction		Wind Loads in y Direction	
	Base Shear	Overturning Moment	Base Shear	Overturning Moment
	kN	kN.m	kN	kN.m
1	4388.7	275766.2	5821.2	333158.8
2	4384.5	275549.0	5715.0	332916.0
3	4374.7	275449.0	5688.0	332512.0
4	4367.0	274896.0	5649.4	331561.1
5	4366.0	274870.0	5517.6	331352.0
6	4346.0	274736.0	5474.9	330061.2
7	4315.0	274443.0	5400.8	329828.4
8	4273.0	274043.0	5303.9	328862.0
9	4227.0	273923.0	5215.8	327764.0
10	4177.0	273701.0	5134.4	326875.0
11	4112.0	273693.3	5071.2	323255.5

Table 8.5. Base shears and overturning moment of 60-story building in y-direction
(Continued)

12	4034.0	273541.9	5015.9	321591.0
13	3869.8	273535.0	4912.5	321178.9
14	3789.6	273388.5	4800.9	319860.0
15	3700.5	273132.0	4726.8	319497.7
16	3612.2	273077.0	4555.1	319381.0
17	3545.1	272772.0	4470.0	318518.0
18	3453.8	272503.2	4386.8	313895.0
19	3385.2	272344.4	4298.4	311438.1
20	3320.0	272035.1	4289.0	308394.2
21	3278.0	271909.0	4110.5	307132.2
22	3216.0	271455.0	4012.8	306326.4
23	3192.0	269114.0	3921.3	303149.0
24	3144.0	268103.0	3827.8	300869.9
25	3113.4	266421.2	3727.4	299878.1
26	3082.4	265148.4	3619.6	295651.8
27	3057.1	262114.8	3521.5	293870.0
28	3021.9	261039.3	3427.4	290080.6
29	2982.4	259906.5	3360.2	276601.0
30	2941.7	257421.4	3258.6	272681.7
31	2893.8	255120.1	3156.7	268687.8
32	2842.8	251642.4	3084.4	254895.6
33	2780.0	249418.0	2975.2	251420.5
34	2714.3	245918.9	2866.0	247945.4
35	2641.9	242577.3	2771.2	240077.3
36	2565.0	239184.8	2669.3	233979.4
37	2486.5	235396.7	2562.9	229065.6
38	2406.1	231918.7	2468.5	220125.4
39	2331.9	226963.2	2364.4	213404.3
40	2259.3	222600.3	2256.9	207088.7
41	2194.9	217495.8	2153.5	199257.1
42	2136.0	212929.3	2063.7	186522.9
43	2086.5	207572.9	1944.7	183512.0
44	2041.5	203050.2	1835.4	176985.1
45	2011.6	195026.0	1735.9	166925.4
46	1981.0	188461.9	1631.0	158442.9
47	1948.5	182888.4	1523.3	149972.5
48	1917.4	175568.8	1416.4	140511.3
49	1881.2	167607.3	1306.6	131869.6

Table 8.5. Base shears and overturning moment of 60-story building in y-direction
(Continued)

50	1831.6	160925.1	1201.0	121466.9
51	1773.8	151722.6	1091.4	112270.3
52	1700.0	142002.1	981.4	103042.5
53	1606.5	131740.1	878.4	90954.2
54	1493.9	119130.9	776.8	78063.1
55	1355.0	106637.1	666.6	68204.1
56	1189.8	93074.0	551.8	59837.8
57	1001.8	75898.6	448.0	46270.7
58	779.6	60424.3	333.1	36184.8
59	534.1	40007.5	221.6	24570.9
60	257.3	18780.4	111.3	12192.9

Table 8.6. Base shears and overturning moment of 40-story building in y-direction.

Story No.	Earthquake Loads in y Direction		Wind Loads in y Direction	
	Base Shear	Overturning Moment	Base Shear	Overturning Moment
	kN	kN.m	kN	kN.m
1	3574.3	126060.9	3654.0	138532.4
2	3562.9	126201.6	3588.3	139492.3
3	3536.1	126266.3	3513.0	138877.3
4	3489.8	126088.5	3436.1	136921.7
5	3417.4	126008.3	3377.7	136490.3
6	3320.7	125988.4	3312.3	135964.5
7	3206.1	125246.2	3227.1	135171.1
8	3067.1	125009.7	3132.1	134377.6
9	2915.1	124598.0	3065.0	133226.3
10	2753.3	124520.3	2972.0	132517.0
11	2602.9	123362.1	2869.0	132261.5
12	2455.8	123158.4	2791.8	131292.1
13	2327.3	122660.4	2700.5	130218.3
14	2224.1	122111.5	2615.5	127845.4
15	2138.7	121887.9	2539.3	123658.9
16	2085.9	120891.1	2447.9	121681.2
17	2044.4	120513.9	2375.4	115536.2
18	2019.2	118872.3	2271.0	115327.9
19	1987.5	118298.4	2173.0	113882.6
20	1947.7	117746.9	2077.3	111505.3
21	1903.8	115778.2	1977.7	109299.3

Table 8.6. Base shears and overturning moment of 40-story building in y-direction
(Continued)

22	1839.6	114734.8	1874.9	107579.2
23	1763.2	113200.2	1798.3	100276.5
24	1681.9	111027.0	1692.6	98828.4
25	1597.4	108915.9	1600.3	94367.6
26	1525.0	107232.0	1503.7	90180.6
27	1520.1	105605.1	1408.0	85279.6
28	1513.6	104118.1	1308.9	80904.9
29	1510.4	100675.2	1209.2	76486.2
30	1481.9	99992.6	1111.5	71404.6
31	1461.6	97439.6	1022.7	64030.9
32	1458.3	94768.4	919.3	59375.9
33	1447.8	92797.1	821.1	52911.3
34	1431.5	88786.4	714.3	48340.9
35	1428.3	82192.5	616.0	41479.5
36	1404.7	78949.0	511.8	35878.0
37	1196.6	64545.2	411.6	29066.9
38	973.9	53036.9	315.3	21005.8
39	690.2	37497.2	210.9	14273.5
40	343.0	18133.2	104.5	7497.7

Two buildings with different number of floors are analyzed to compare the effect of building height on analysis both wind and earthquake. The heights of 60-story and 40-story buildings are 210m and 140m respectively.

Figure 8.3 compares the shear forces at the base of two buildings in kN for both wind and earthquake along x-direction which is normal to the long direction of the buildings, while Figure 8.4 compares the shear forces at the base of buildings in kN for both wind and earthquake along y-direction. Figure 8.5 compares the moments at the base of two buildings in ton for both wind and earthquake along x- direction which is normal to the long direction of the buildings, while Figure 8.6 compares the moments at the base of the buildings in ton for both wind and earthquake along y- direction which is normal to the short direction of the buildings.

It is shown that wind is more effective than earthquake for tall buildings when results of analysis are considered. The wind effect increases rapidly when the height of the building increases. The shear forces and the moments at the base resulted from wind when the load is applied normal to the long direction, i.e. y- direction, are more than that resulted when applied on the short direction. In this study according to comparison results, these two buildings should be designed in both directions independently for the critical forces of wind.

9. DESIGN SECTIONS OF MEMBERS

In member section design procedure, ascendant forces are considered as derivations of wind loading and combinations of wind loading. In previous section, it is presented that wind loading impacts are more important than earthquake loading impacts on high rise buildings. The design sections of beams and columns are determined by making use of specifications of LRFD. All beams sections are chosen I-shape and all sections of column members are chosen H-shape.

The cross-section dimension and thickness of the column members decrease from bottom to top stories of buildings. The members sections are changed at every ten stories. In order to have same sections columns are grouped for each ten stories. Moreover, similar column blocks are grouped into five different groups as shown in Figure 9.1.

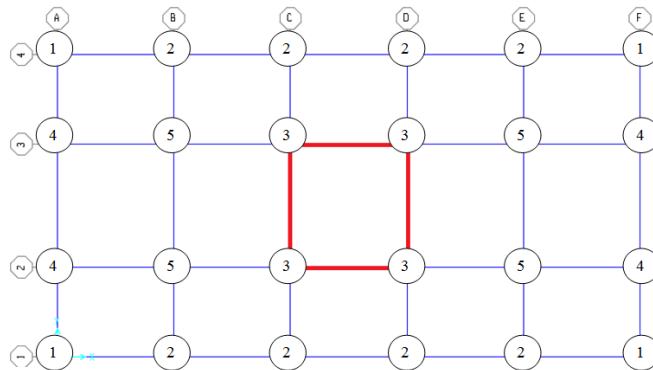

Figure 9.1. Group number of column groups on floor plan.

Table 9.1. Design sections of column groups of 60-story building.

Story No.	Column Groups				
	1	2	3	4	5
60 - 50	HE200A	HE240A	HLS100	HE280A	HE340B
50 - 40	HE240A	HE360A	HLS100	HE450A	H400X262
40 - 30	HE300A	HE450B	HE200A	HE600B	H400X383
30 - 20	HE360A	HE300M	HE360A	HE550M	H400X509
20 - 10	HE360B	HE600M	HE900M	HE1000M	H400X634
10 - 0	HE450B	HE1000M	H400X593	H400X393	H400X818

Table 9.2. Design sections of column groups of 40-story building.

Story No.	Column Groups				
	1	2	3	4	5
40 - 30	HE200A	HE240A	HE100A	HE280A	HE340B
30 - 20	HE240A	HE360A	HE120A	HE450A	HE500M
20 - 10	HE300A	HE450B	HE160A	HE600B	H400X383
10 - 0	HE360A	HE300M	HE280A	HE550M	H400X509

The design sections of the column groups of 60-story building are shown in Table 9.1 and the design sections of the column groups of 40-story building are shown in Table 9.2. The sections of beams are chosen same for each floor plan of each building analyzed in this study. Beams are I-shape profile members. Beams sections are shown in Figure 9.2.

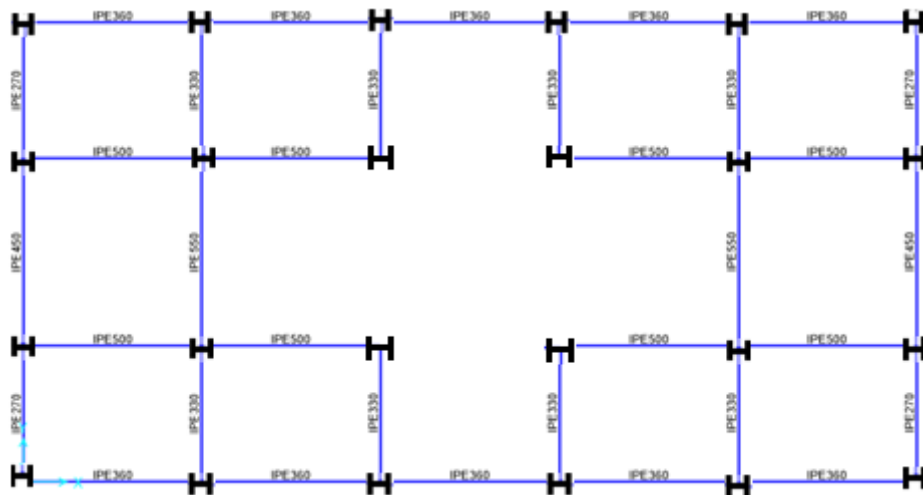

Figure 9.2. Design sections of beams of floor plan.

By defining LRFD provisions in SAP2000 program, all structural members are analyzed according to demand capacity ratio limitation. Forces from resulting analysis demand of structures are compared with strength to provide a demand-capacity ratio for actions at each member of structures. Simply, a ratio greater than 1 implies failure. In this study, all demand-capacity ratios are analyzed by software program. Instead of showing the results of each members of each story, one floor plan and some longitudinal sections are demonstrated with ratio values of members.

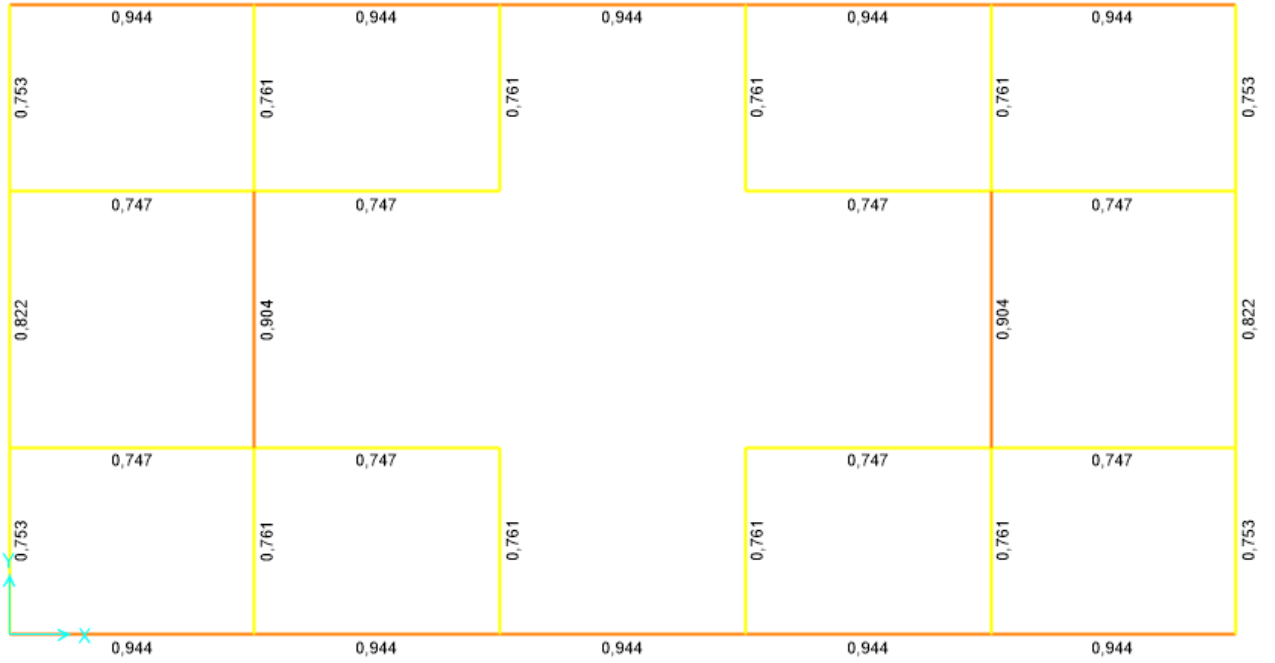

Figure 9.3. X-Y plane view of beam elements with d/c ratio.

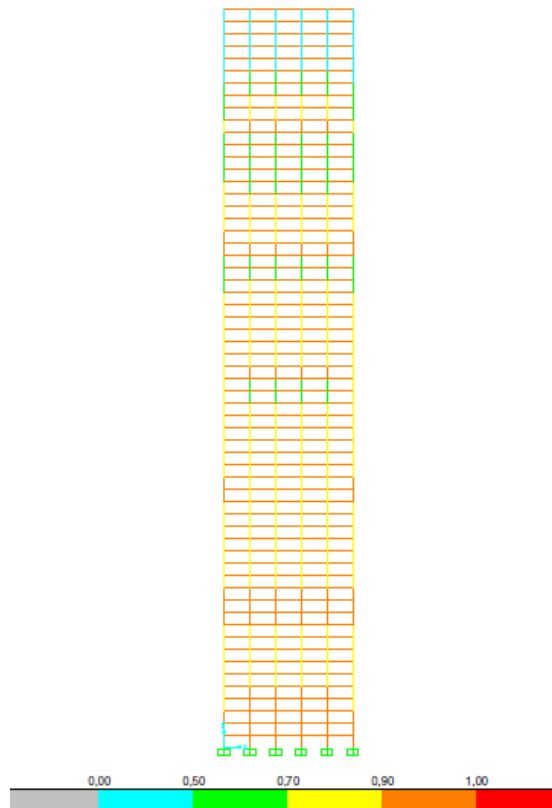

Figure 9.4. X-Z view of 60-story building with d/c ratio.

10. ANALYSIS AND RESULTS OF STUDY CASES

In this part of the study, two study cases are presented. Descriptions of model of each building are addressed comprehensively in the previous sections of study. Floor plans, specifications of the buildings and material features are same in both study cases. Only difference occurs in the number of stories. For both cases, optimum location of outrigger and belt truss systems investigation is conducted. By changing the number of outrigger and belt truss systems, several analyses are performed and according to these analyses results, the comparison tables and graphics are obtained. Moreover, in order to understand the effects of belt truss on buildings, three different types of belt truss systems are applied on buildings and results are compared. All these analyses results are obtained by using SAP2000.

10.1. Study Case 1: 40-Story Building

In the scope of this study, the building is analyzed for the lateral loads acting on the building. The wind loads are calculated based on ASCE7-10 for Göztepe region, Istanbul and earthquake load are calculated based on TEC 2007 in previous sections. The wind loads are varied along the height of structure.

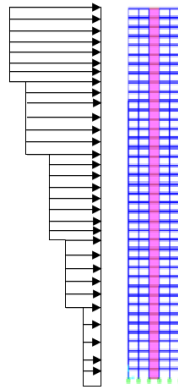

Figure 10.1. Diagrammatic representation of wind loads on 40-story steel building.

There are some factors affecting the effectiveness of outrigger system. They are the stiffness and location of the outrigger and belt truss system, the geometry, the core, and floor to floor height of the building. In this study, all cases have same geometry and structural features. The factors which affect the effectiveness of outrigger system are the locations on buildings and stiffnesses. Hence, series of analysis are performed based on these parameters.

In the process of determination of optimum location of outrigger systems, all analyzes are conducted by using conventional outrigger system. Conventional outrigger system consists of diagonal braces and is applied along the one floor.

10.1.1. Determination of Optimum Location of Single Outrigger System on 40-Story Building

In order to determine location of single outrigger system on 40-story building, various models are run. For each story level, one model is run. In total 40 models are run. Among these models, the model provides maximum stiffness of the outrigger and belt truss and minimum lateral deflection of building is chosen. Figure 10.2 shows that the best location for single outrigger option is at level 29 of building.

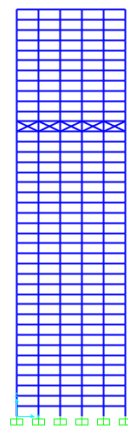

Figure 10.2. Optimum location of single outrigger system on 40-story building.

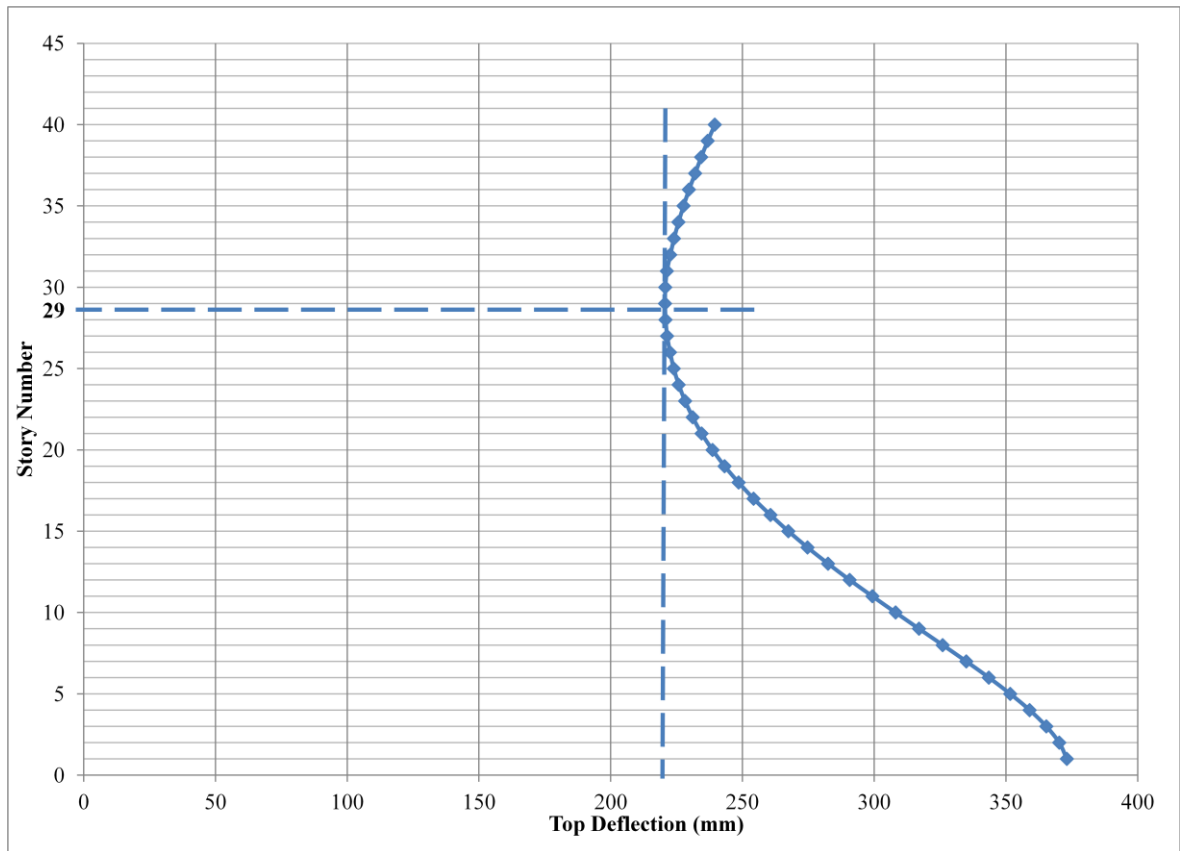

Figure 10.3. Graph of top deflection and number of story for optimum location of single outrigger system on 40-story building.

10.1.2. Determination of Optimum Location of Two Outrigger Systems on 40-Story Building

In order to determine location of two outrigger systems on 40-story building, various models are run. For each story level, one model is run. In total 39 models are run. In order to obtain minimum lateral deflection, one of two outrigger systems is fixed at top level. Among these 39 models, the model provides maximum stiffness of the outriggers and belt trusses and minimum lateral deflection of building is chosen. The best location for second outrigger system is 23 level of building while one is fixed at top level.

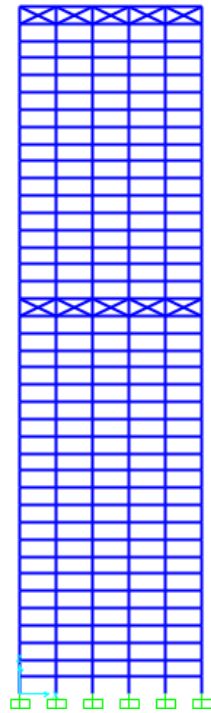

Figure 10.4. Optimum location of two outrigger systems on 40-story building.

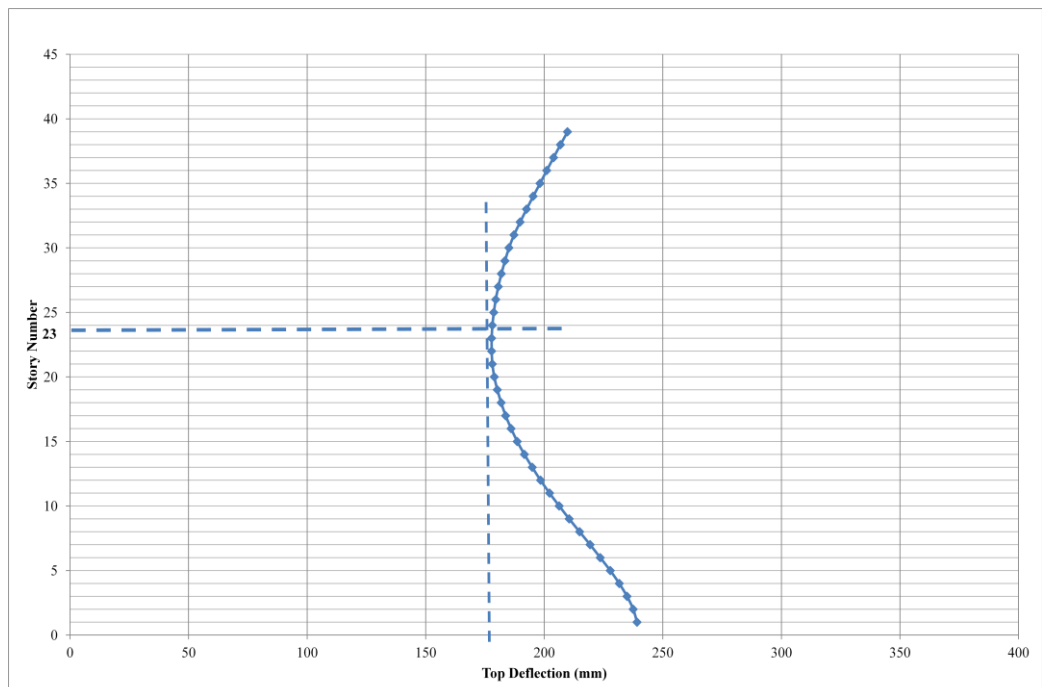

Figure 10.5. Graph of top deflection and number of story for optimum location of two outrigger systems on 40-story building.

10.1.3. Determination of Optimum Location of Three Outrigger Systems on 40-Story Building

In order to determine location of three outrigger systems on 40-story building, various models are run. Three outrigger options are run for various arrangements of levels. These levels for arrangements are shown in Table 8.1. The obtained optimum locations of outrigger systems are at level 40, 30 and 20 respectively. During the analyses conducted, one location for the outrigger and belt truss is fixed at the top level. In order to get best location of rest of the two cross bracings, many models are run.

Table 10.1. Various arrangements for three outrigger system options of 40-story building.

Arrangement	Outrigger Levels		
No : 1	40	30	20
No : 2	40	25	15
No : 3	40	30	15
No : 4	40	32	23
No : 5	40	35	25
No : 6	40	30	10
No : 7	40	35	30

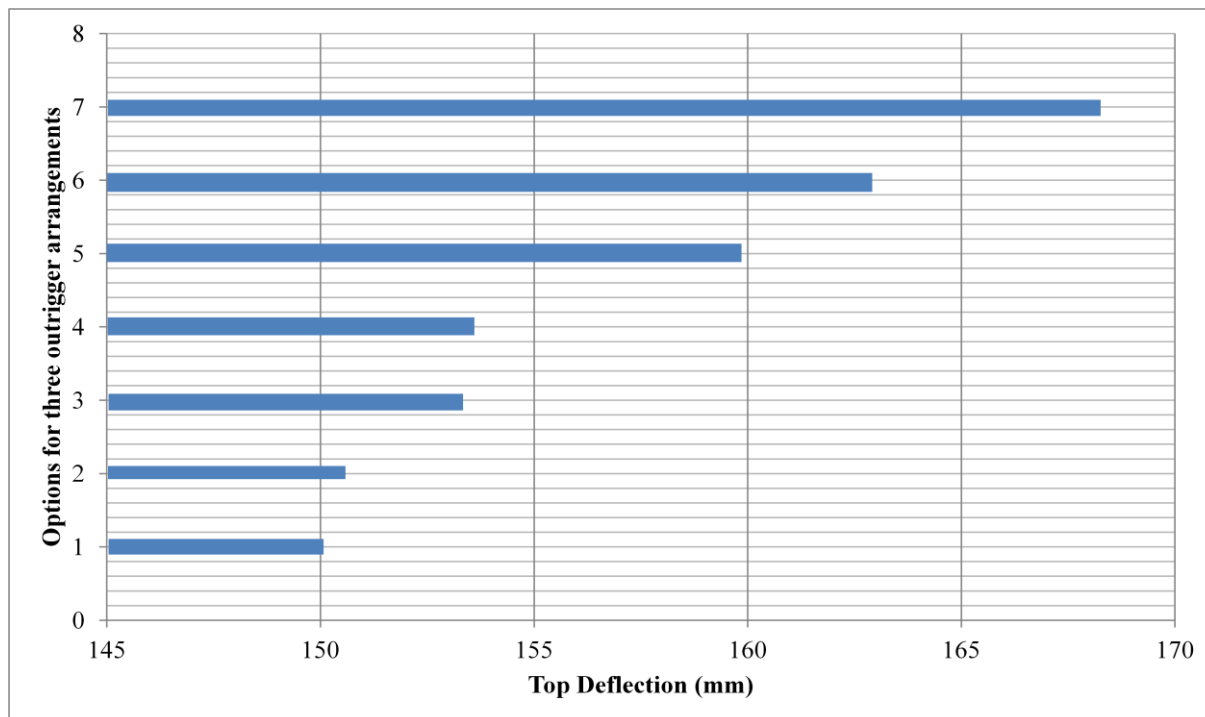

Figure 10.6. Graph of top deflection and arrangements for optimum location of three outrigger systems on 40-story building.

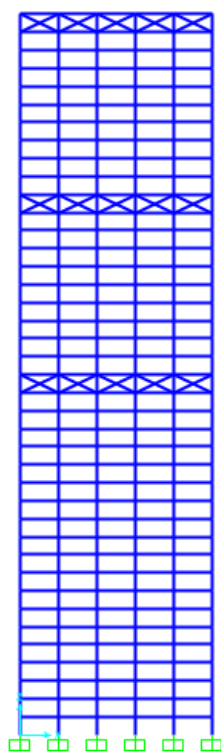

Figure 10.7. Optimum location of three outrigger systems on 40-story building.

10.1.4. Comparison of Various Outrigger Systems on 40-Story Building

The outrigger systems are employed to utilize the full capacities of the structural form. Three different models of outrigger system used in analysis are described in previous sections. In this section, four options of outrigger models are compared, including the structure without any outriggers. In order to compare these models to each other, basic model arrangements should be described. These models are described explicitly below.

- Model without outrigger and belt truss system (MT0).
- Model with one outrigger and belt truss system (MT1).
- Model with double outrigger and belt truss systems (MT2).
- Model with three outrigger and belt truss system (MT3).

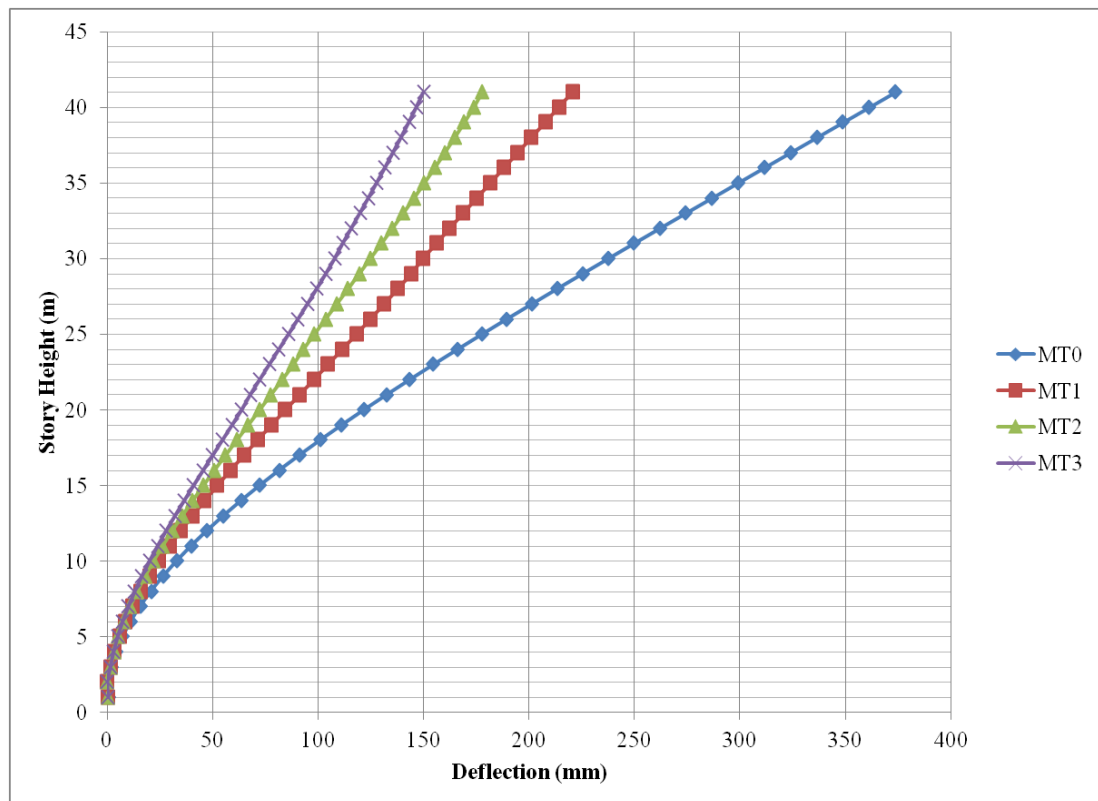

Figure 10.8. Comparison of various outrigger options of 40-story building.

Table 10.2. Maximum displacement and percentage reduction in deflection for each option of 40-story building.

Outrigger Options	MT0	MT1	MT2	MT3
Δ @ Top (mm)	373,62	220,59	177,78	149,99
% Reduction in Δ	–	41%	52%	60%

The use of outrigger and the belt truss has improved the serviceability of the structure. Four options are compared in Figure 8.8, including the structure without any outriggers. The results show appreciable decline in the deflection with the use of outrigger system. There is 41% reduction by the use of one outrigger at the effective level. Whereas 52% and 60% drop is achieved by the use of two and three outrigger levels with respect to MT0 in Table 10.2.

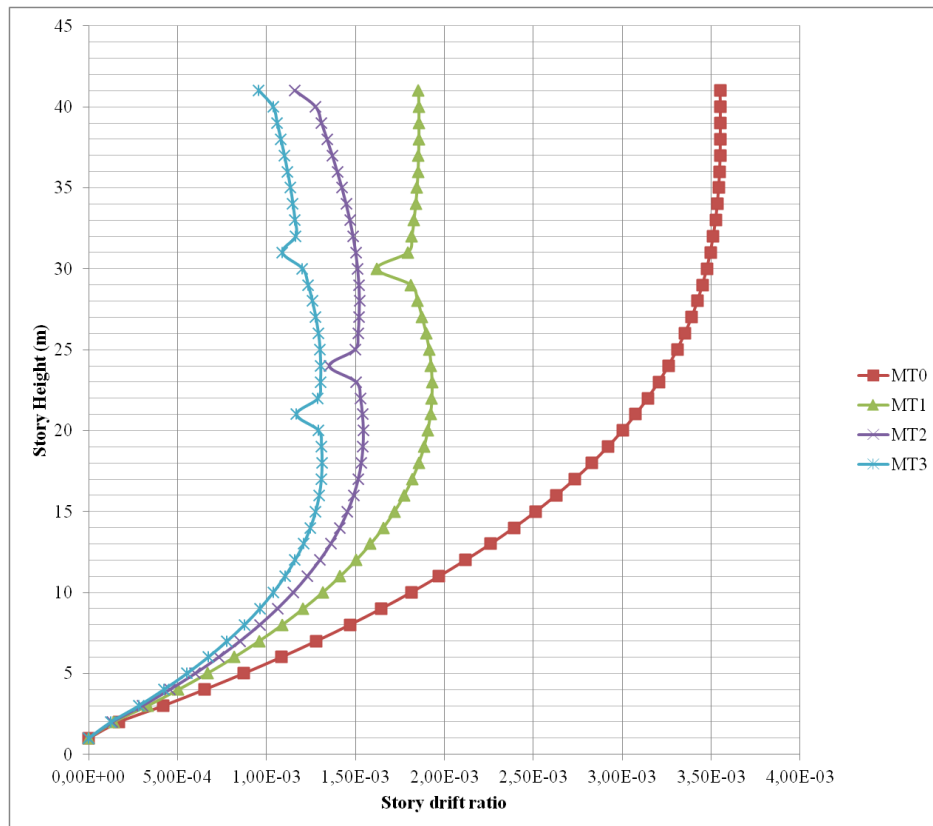

Figure 10.9. Story drift comparison of various outrigger options.

There is a sudden fluctuation and change in the gradient of slope with the addition of outrigger levels as can be seen in Figure 10.9. The outrigger levels for MT1 and MT2 are level 29, level 23 respectively whereas outriggers are provided at level 30 and level 20 for MT3. This variation indicates the higher stiffness at these levels. This stiffness is helping the structure to control the inter-storey drift and consequently minimizing the displacements of the building. A similar trend in the percentage reduction of storey drift is also obtained. Table 10.3 shows deflection reduction of different outrigger arrangements.

Table 10.3. Maximum story drift and percentage reduction in story drift for each option of 40-story building.

Outrigger Options	MT0	MT1	MT2	MT3
Max. drift δ (mm)	3.55E-03	1.85E-03	1.16E-03	9.56E-04
% Reduction in δ	–	48%	67%	73%

10.1.5. Comparison of Different Types of Outrigger Systems on 40-Story Building

In this section, modified outrigger and belt truss structural system will be examined under lateral loadings. Different types of outrigger systems are placed on the same building structure and under the same load conditions. Three different systems have been selected for comparison. These systems are shown in Figure 10.10. The floor levels are achieved according to the results of the previous determination of optimum location analyses. These floor levels are the same for all three cases. Floor levels are 40th, 30th and 20th respectively.

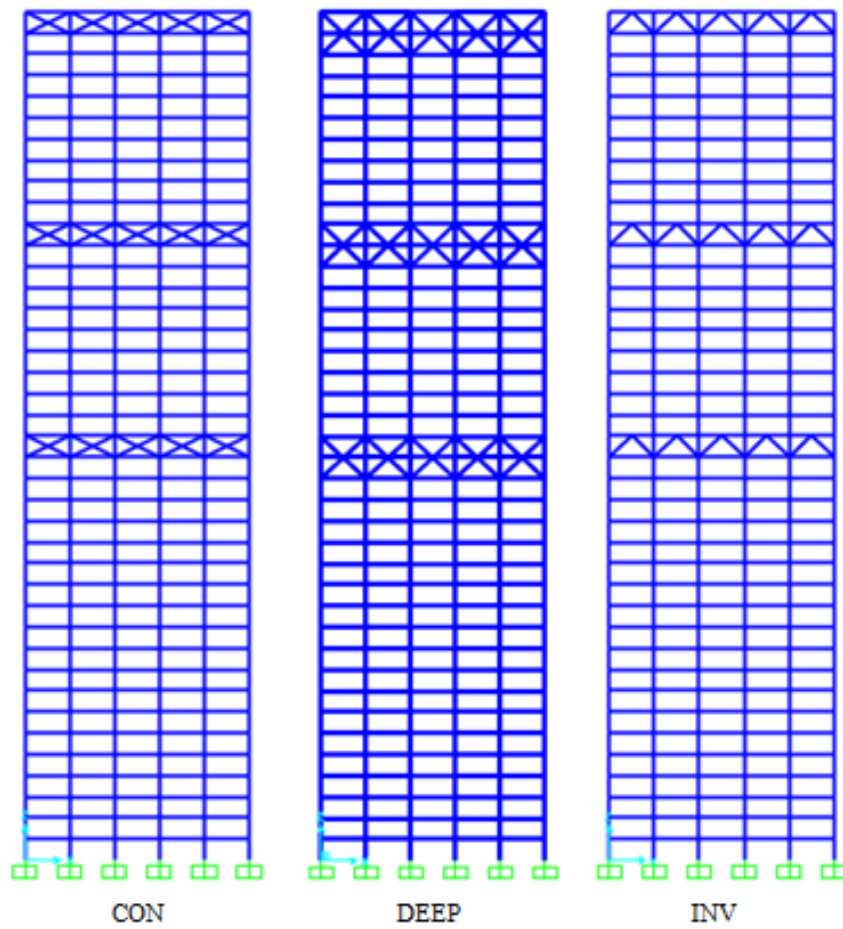

Figure 10.10. Different types of outrigger and belt truss systems on 40-story building.

A total of 3 different types of outrigger and belt truss system analyzed using SAP2000 software program are;

- Conventional outrigger system (CON)
- Deep outrigger system (DEEP)
- Inverted v outrigger system (INV)

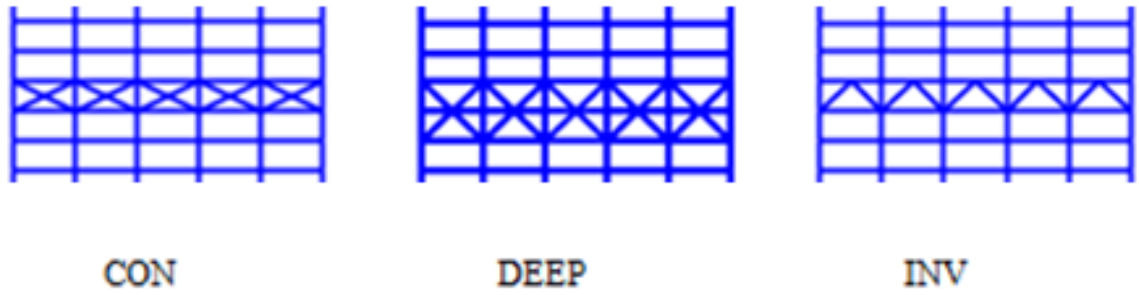

Figure 10.11. Section cuts of different types of outrigger and belt truss systems.

In conventional outrigger system, all braces are cross bracing located on same level of building. Deep outrigger system braces are located on two height of floor. This system provides architectural design flexibility for placement of inner story elements such as walls and floors. In inverted v outrigger system, braces are intersected in the middle of the slab of next level.

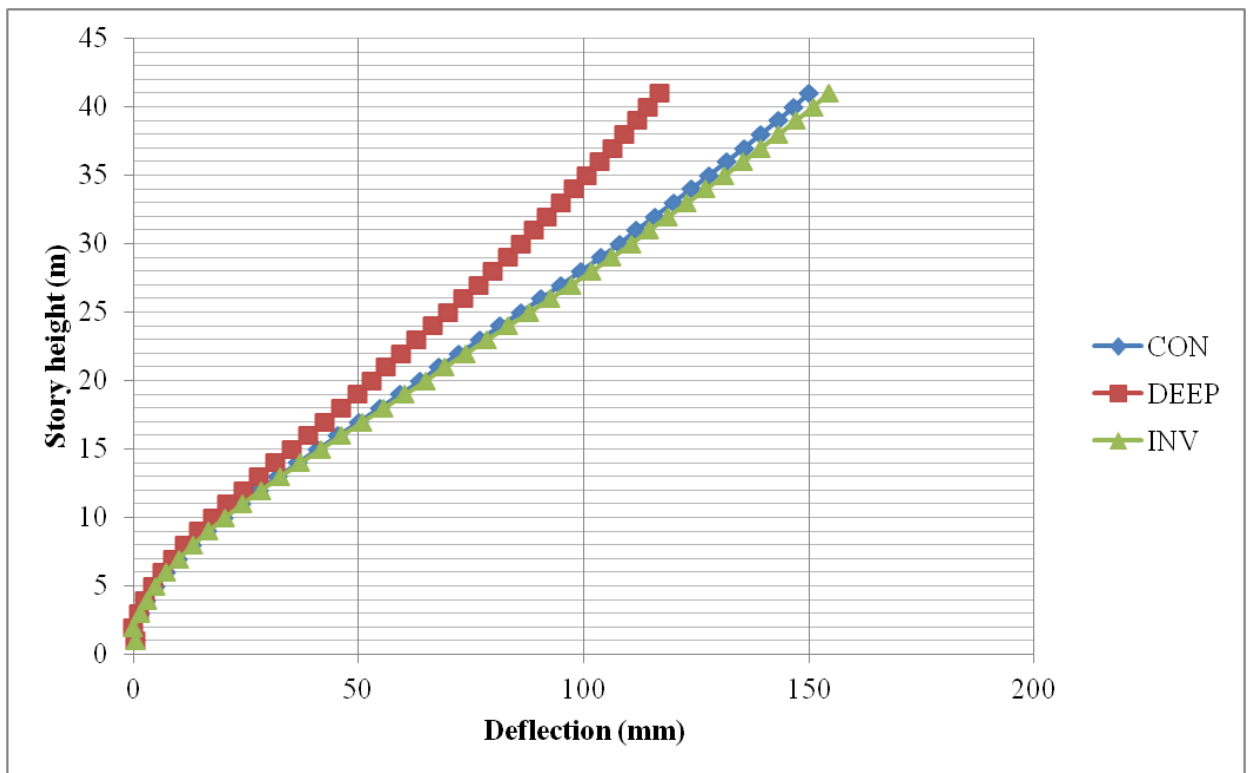

Figure 10.12. Graph of deflection different types of outrigger and belt truss systems on 40-story building.

As shown in Figure 10.12, two of three different outrigger systems results demonstrate approximate values for each level whereas deep outrigger system provides %41 reduction in deflection compared to conventional and inverted v outrigger systems.

Table 10.4. Displacement comparison of three types of outrigger systems of 40-story building.

Outrigger Systems	INV	DEEP	CON
Δ @ Top (mm)	154.34	116.74	149.99
% Reduction in Δ	–	24%	3%

10.2. Study Case 2: 60-Story Building

In the scope of this study, the building is analyzed for the lateral loads acting on the building. The wind loads are calculated based on ASCE7-10 for Göztepe region, Istanbul and earthquake load are calculated based on TEC 2007 in previous sections. The wind loads are varied along the height of structure.

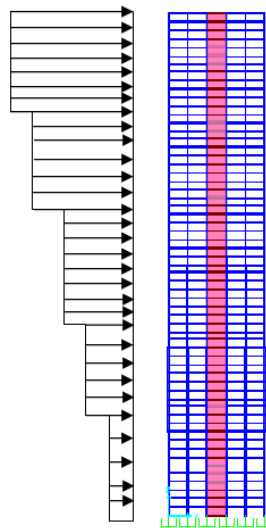

Figure 10.13. Diagrammatic representation of wind loads on 60-story building.

There are some factors affecting the effectiveness of outrigger system. They are the stiffness and location of the outrigger and belt truss system, the geometry, the core, and floor to floor height of the building. In this study, all cases have same geometry and structural features. The factors which affect the effectiveness of outrigger system are the locations on buildings and stiffnesses. Hence, series of analysis are performed based on these parameters.

In the process of determination of optimum location of outrigger systems, all analyzes are conducted by using conventional outrigger system. Conventional outrigger system consists of diagonal braces and is applied along the one floor.

10.2.1. Determination of Optimum Location of Single Outrigger System on 60-Story Building

In order to determine location of single outrigger system on 60-story building, various models are run. For each story level, one model is run. In total 60 models are run. Among these models, the model provides maximum stiffness of the outrigger and belt truss and minimum lateral deflection of building is chosen. Figure 10.14 shows that the best location for single outrigger option is at level 40 of building.

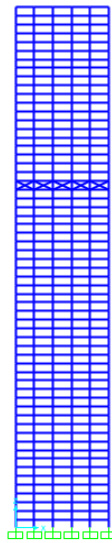

Figure 10.14. Optimum location of single outrigger system on 60-story building.

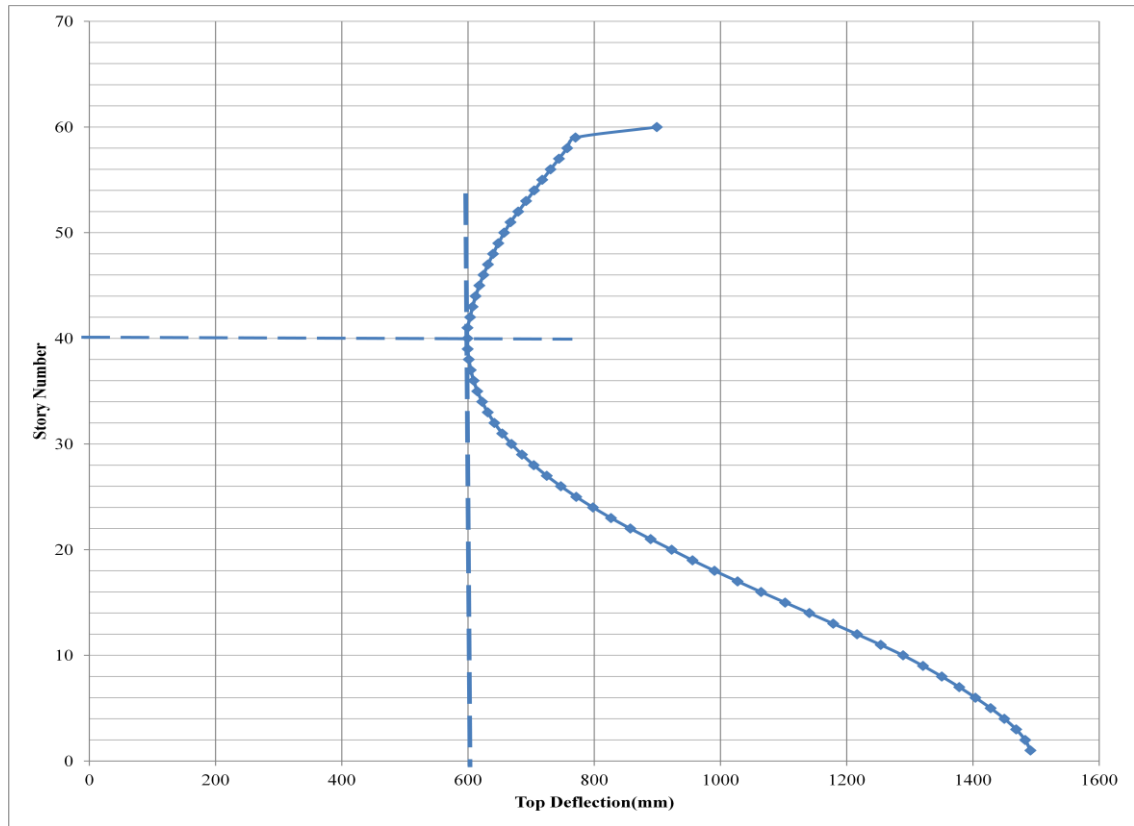

Figure 10.15. Graph of top deflection and number of story for optimum location of single outrigger system on 60-story building.

10.2.2. Determination of Optimum Location of Two Outrigger Systems on 40-Story Building

In order to determine location of two outrigger systems on 60-story building, various models are run. For each story level, one model is run. In total 59 models are run. In order to obtain minimum lateral deflection, one of two outrigger systems is fixed at top level. Among these 59 models, the model provides maximum stiffness of the outriggers and belt trusses and minimum lateral deflection of building is chosen. The best location for second outrigger system is 32 level of building while one is fixed at top level.

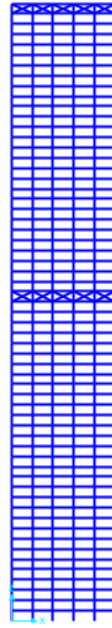

Figure 10.16. Optimum location of two outrigger systems on 60-story building.

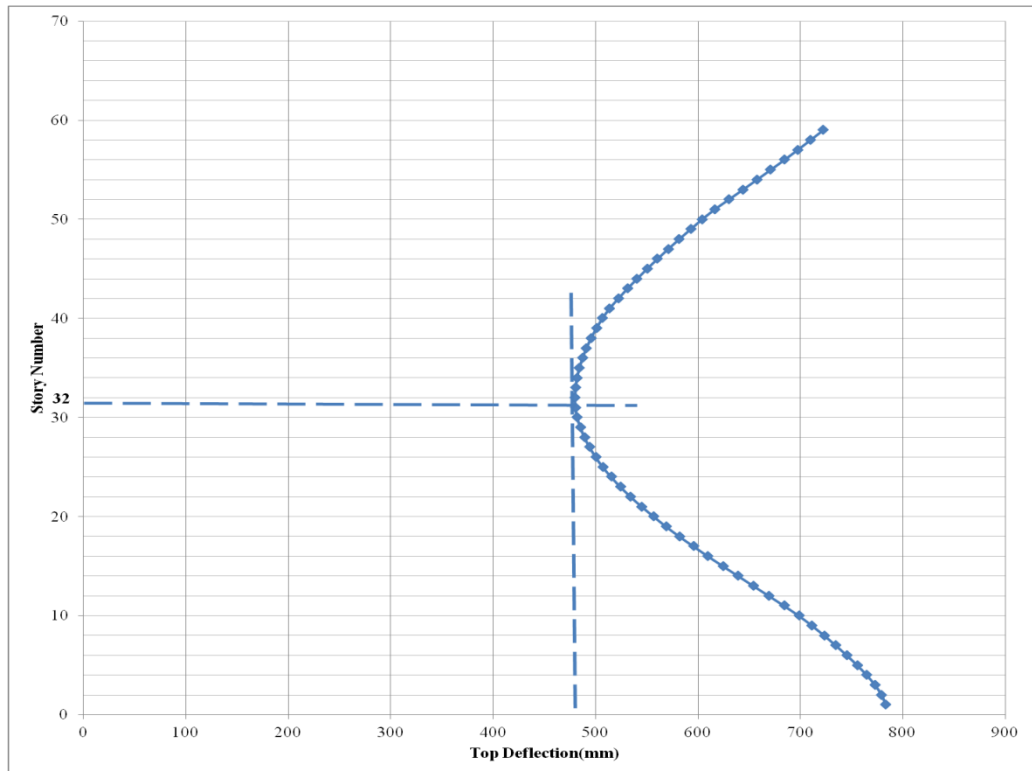

Figure 10.17. Graph of top deflection and number of story for optimum location of two outrigger systems on 60-story building.

10.2.3. Determination of Optimum Location of Three Outrigger Systems on 60-Story Building

In order to determine location of three outrigger systems on 60-story building, various models are run. Three outrigger options are run for various arrangements of levels. These levels for arrangements are shown in Table 8.5. The obtained optimum locations of outrigger systems are at level 60, 35 and 25 respectively. During the analyses conducted, one location for the outrigger and belt truss is fixed at the top level. In order to get best location of rest of the two cross bracings, many models are run.

Table 10.5. Various arrangements for three outrigger system options of 60-story building.

Arrangement	Outrigger Levels		
No : 1	60	35	25
No : 2	60	35	23
No : 3	60	37	25
No : 4	60	40	30
No : 5	60	40	20
No : 6	60	45	15
No : 7	60	50	30

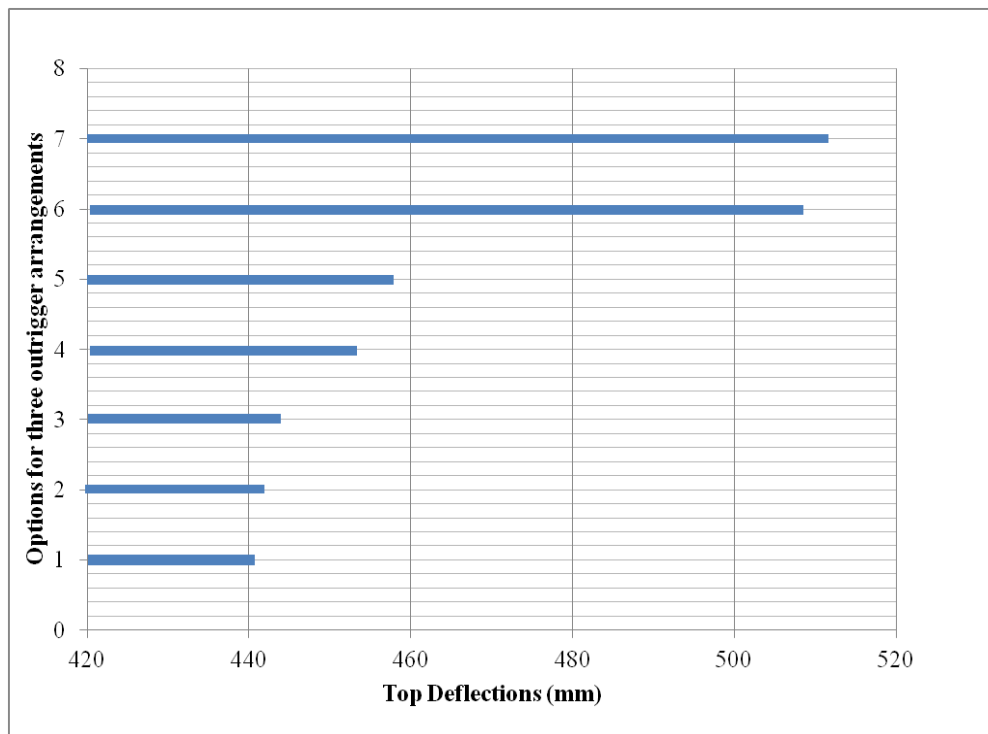

Figure 10.18. Graph of top deflection and arrangements for optimum location of three outrigger systems on 60-story building.

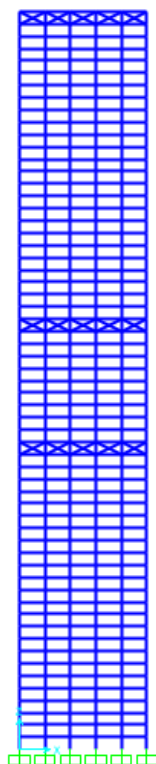

Figure 10.19. Optimum location of three outrigger systems on 60-story building.

10.2.4. Comparison of Various Outrigger Systems on 60-Story Building

The outrigger systems are employed to utilize the full capacities of the structural form. Three different models of outrigger system used in analysis are described in previous sections. In this section, four options of outrigger models are compared, including the structure without any outriggers. In order to compare these models to each other, basic model arrangements should be described. These models are described explicitly below.

- Model without outrigger and belt truss system (MT0).
- Model with one outrigger and belt truss system (MT1).
- Model with double outrigger and belt truss systems (MT2).
- Model with three outrigger and belt truss system (MT3).

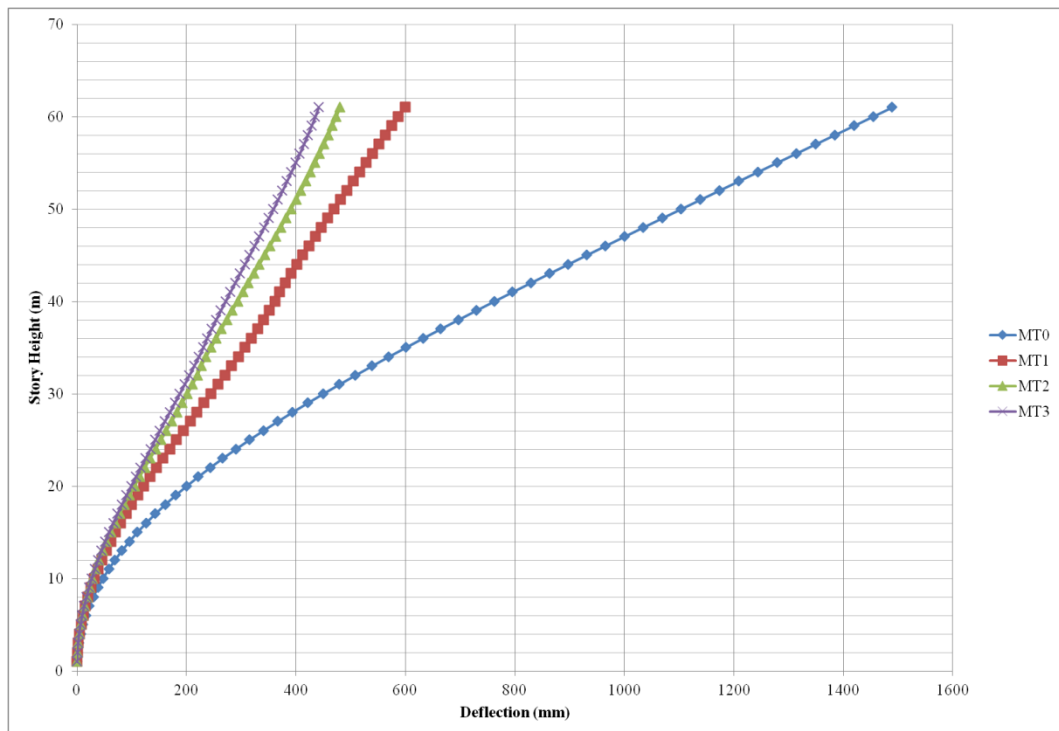

Figure 10.20. Comparison of various outrigger options of 60-story building.

Table 10.6. Maximum displacement and percentage reduction in deflection for each option of 60-story building.

Outrigger Options	MT0	MT1	MT2	MT3
Δ @ Top (mm)	1489.24	598.926	479.791	440.844
% Reduction in Δ	–	60%	68%	70%

The use of outrigger and the belt truss has improved the serviceability of the structure. Four options are compared in Figure 10.19, including the structure without any outriggers. The results show appreciable decline in the deflection with the use of outrigger system. There is 60% reduction by the use of one outrigger at the effective level. Whereas 68% and 70% drop is achieved by the use of two and three outrigger levels with respect to MT0 in Table 10.6.

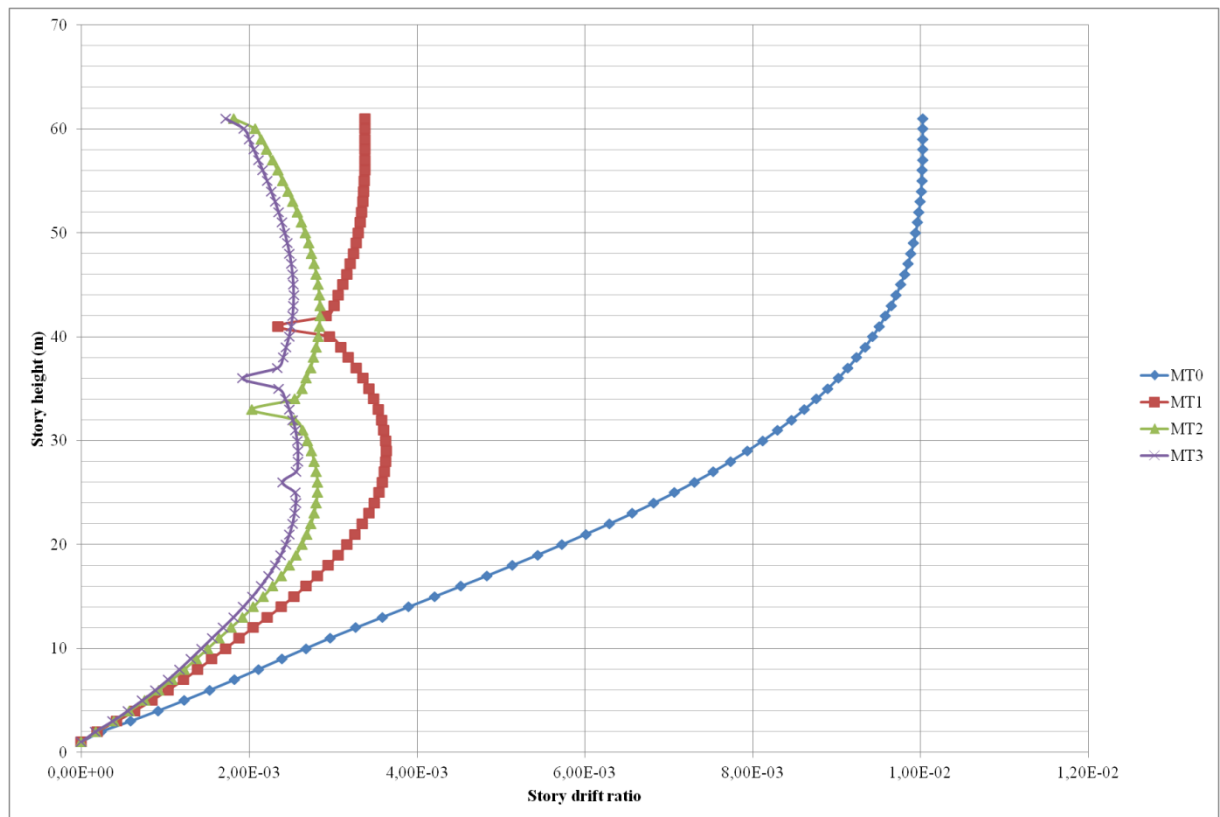

Figure 10.21. Story drift comparison of various outrigger options.

There is a sudden fluctuation and change in the gradient of slope with the addition of outrigger levels as can be seen in Figure 10.20. The outrigger levels for MT1 and MT2 are level 40, level 32 respectively whereas outriggers are provided at level 35 and level 25 for MT3. This variation indicates the higher stiffness at these levels. This stiffness is helping the structure to control the inter-story drift and consequently minimizing the displacements of the building. A similar trend in the percentage reduction of storey drift is also obtained. Table 10.7 shows deflection reduction of different outrigger arrangements.

Table 10.7. Maximum story drift and percentage reduction in story drift for each option of 60-story building.

Outrigger Options	MT0	MT1	MT2	MT3
Max. drift δ (mm)	1.00E-02	3.38E-03	1.82E-03	1.72E-03
% Reduction in δ	–	66%	82%	83%

10.2.5. Comparison of Different Types of Outrigger Systems on 60-Story Building

In this section, modified outrigger and belt truss structural system will be examined under lateral loadings. Different types of outrigger systems are placed on the same building structure and under the same load conditions. Three different systems have been selected for comparison. These systems are shown in Figure 8.21. The floor levels are achieved according to the results of the previous determination of optimum location analyses. These floor levels are the same for all three cases. Floor levels are 60th, 35th and 25th respectively.

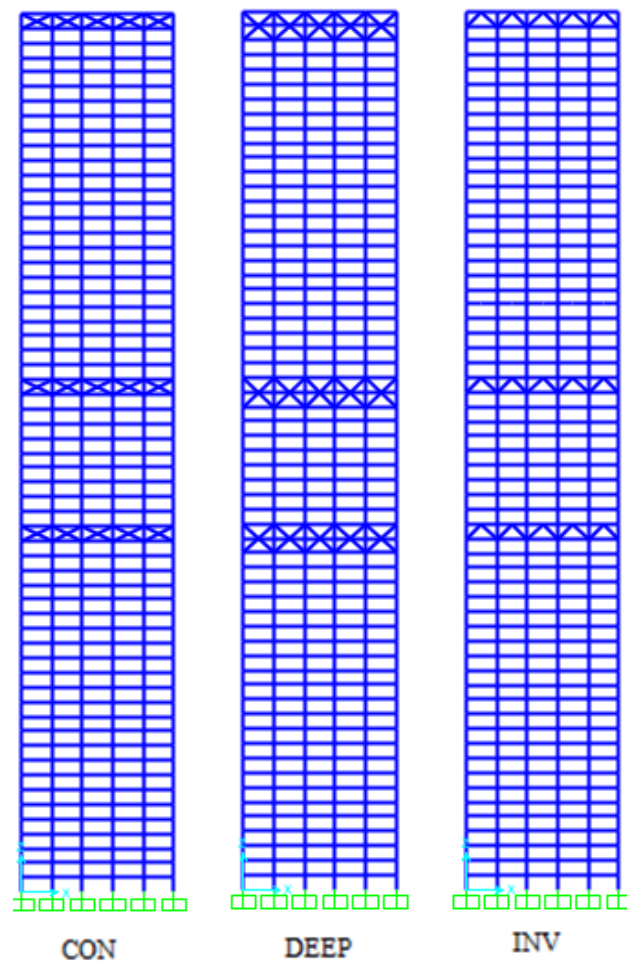

Figure 10.22. Different types of outrigger and belt truss systems on 60-story building.

A total of 3 different types of outrigger and belt truss system analyzed using SAP2000 software program are;

- Conventional outrigger system (CON)
- Deep outrigger system (DEEP)
- Inverted v outrigger system (INV)

In conventional outrigger system, all braces are cross bracing located on same level of building. Deep outrigger system braces are located on two height of floor. This system

provides architectural design flexibility for placement of inner story elements such as walls and floors. In inverted v outrigger system, braces are intersected in the middle of the slab of next floor.

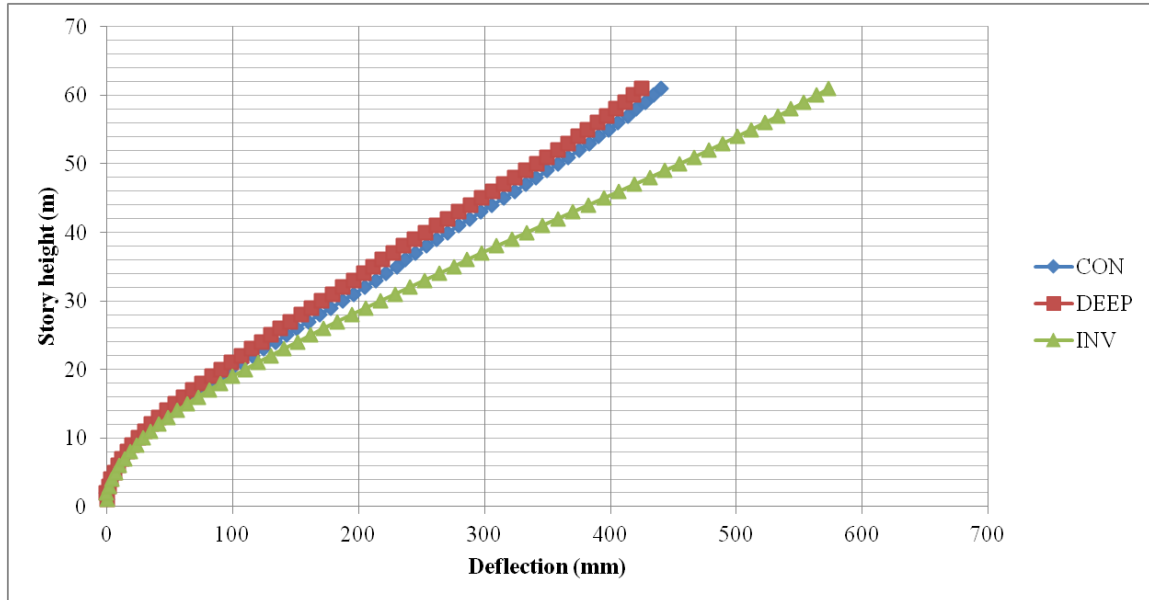

Figure 10.23. Comparison of different types of outrigger systems on 60-story building.

As shown in Figure 10.22, two of three different outrigger systems results demonstrate approximate values for each level. Deep outrigger system and conventional outrigger system provide 26% and 23% reduction in deflection compared to results of 60-story building with inverted v outrigger system.

Table 10.8. Displacement comparison of three types of outrigger systems of 60-story building.

Outrigger Systems	INV	DEEP	CON
Δ @ Top (mm)	573.36	425.05	440.84
% Reduction in Δ	–	26%	23%

9. CONCLUSION

In this thesis study, analysis and design of forty story and sixty story high rise steel buildings have been carried out according to provisions of ASCE 7-10, LRFD-93 and Turkish Earthquake Code 2007. The buildings are designed for office use. They are 140 m and 210 m height. Both buildings have same material properties and floor plan dimensions which are 19.2 m and 37 m. The plan geometry of buildings is rectangle. Modelling of the building is established in SAP2000 structural analysis program.

According to provisions of chosen codes, various kinds of loads such as dead and live are applied on 40-story and 60-story buildings. By projecting the buildings as office, 2.2 kN/m^2 as dead load and 2.4 kN/m^2 as live load are obtained from ASCE7-10. These loads are applied on beams as distributed loads. Each value of distributed load is calculated according to slab area and short span of this area. These values are applied as a trapezoid shape or triangle shape on beam by considering the placement of beam.

In order to determine wind load values, provisions about wind load calculations of ASCE7-10 are used. This load is applied on buildings as windward and leeward loads. The magnitude of calculated wind load depends on wind velocity and the subjected area. In this study, calculations for each subjected area and the design wind speed are obtained from the results of a study including region-specific statistical analysis of wind data. In this study, fifty-year return period design wind speed of Göztepe, Istanbul having a ninety-five percent confidence level is used. Beside the wind load, earthquake load has big impact on high rise buildings. In this study, considering the site of buildings, Göztepe, Istanbul, calculations are carried out according to provisions of Turkish Earthquake Code 2007. Thus, the design factors such as soil class, spectrum characteristic period, building importance factor and structural system behaviour factor are obtained from Turkish

Earthquake Code 2007. The buildings heights are 140 m and 210 m which are not applicable for equivalent seismic load method. Thus, mode superposition method is carried out by SAP2000 software program for both buildings. Obtained base shear forces and overturning moments due to wind and earthquake in both directions of buildings are compared in order to determine critical loading. These comparison results show that values of forces and moments due to wind in long direction of building are bigger than values due to earthquake in long direction of building. Moreover, the wind effect increases rapidly when the height of the building increases. The difference between wind and earthquake base shear forces and overturning moment decreases when the height of the building decreases up to a certain point. In this study, it is shown that the difference between wind and earthquake base shear forces and moments of 40-story building is less than the difference of 60-story building

Wind loading is one of the major design issues when the structure is a high rise building. By the help of current high strength materials, high rise buildings are lighter and more flexible compare to past. At the same time flexible buildings are more affected in terms of wind forces. High lateral deflections, high story drift values and big values of oscillation of building result from flexibility character of high rise buildings. In order to avoid these negative effects of wind induced forces on high rise buildings, lately new engineering solutions are examined and it is found that the solutions create more effective and livable buildings. One of these solutions is outrigger and belt truss system.

In this study, the use of outrigger and belt truss system for high-rise steel buildings subjected to wind is analyzed and compared to find the lateral displacement reduction related to the outrigger and belt system location. In order to find optimum location and most effective structural variety of outrigger and belt truss system, many analyses are run by changing numbers, locations and structures of outrigger systems. For determination of the optimum single outrigger and belt truss on 40-story building, 40 different analyses are run by changing the location of system floor by floor. 29th floor of building is chosen optimum location for single outrigger and belt truss system by checking the reduction

percent of lateral deflection. The reduction in lateral deflection is 41% as compared to a model without outrigger system. In order to specify optimum location of three outrigger option, 7 arrangements are analyzed by changing locations of outrigger systems for each arrangement. Among these 7 arrangements, one which provides maximum reduction in lateral deflection is chosen. For 40-story building, 40th, 30th and 20th floors are specified as optimum location of outrigger systems. The reduction in lateral deflection is 60% as compared to a model without outrigger system. Same analysis method is followed for 60-story building and optimum locations are 60th, 35th and 25th levels. In this arrangement, 70% lateral deflection reduction and 83% maximum drift reduction occur as compared to a model without outrigger system.

In additional these analyses, in order to analyze effects of structural alteration of outrigger and belt truss system, three different types of outrigger systems are examined. These structures analyzed are conventional, deep and inverted v outrigger systems. For 40-story and 60-story buildings reductions in lateral displacement of different type of outrigger systems are compared. Respectively, 24% and 26% reduction are observed for 40-story and 60-story buildings as compared to a model with conventional outrigger system. Innovative structural schemes are continuously being sought in the field. Structural design of high-rise structures with the intention of limiting the drift due to lateral loads to acceptable limits without paying a high premium in steel tonnage. The savings in steel tonnage and cost can be dramatic if certain techniques are employed to utilize the full capacities of the structural elements. In this study outrigger and belt truss system used is one of these techniques which help to reduce the total price of building. As it is shown in the results of analysis that outrigger and belt truss systems help to minimize element sections by increasing lateral stiffness of building. This enables to save big amount of money in the construction process. In this study in order to demonstrate the comparisons of lateral movements and drifts of buildings, the section of elements are not altered for each buildings. During the earthquake analysis linear dynamic analysis is carried out. In further researches, nonlinear dynamic analysis can be investigated to observe the reaction of high rise buildings.

REFERENCES

- American Society of Civil Engineers, ASCE7-10, 2010, Minimum Design Loads for Buildings and Other Structures, Reston, USA.
- Chang, F., K., Chen C., "Outrigger System Study For Tall Building Structure with Central Core and Square Floor Plate," CTBUH 2004, October 10-13, Seoul, Korea.
- CTBUH, Council on tall buildings and urban habitat, "Structural systems for tall buildings", McGraw-Hill, 1995.
- Fawzia.S. and Fatima.T (2010), "Deflection Control in Composite Building by Using Belt Truss and Outriggers Systems", World Academy of Science, Engineering and Technology 72.
- Gerasimidis, S., Efthymiou, E. and Baniotopoulos, C., "Optimum outrigger locations of high-rise steel buildings for wind loading", EACWE 5, Florence, Italy, (2009).
- Gustafsson, D., Hehir, J., 2005, "Stability of Tall Buildings", Department of Civil and Environmental Engineering, Chalmers University of Technology.
- Iyengar, S.H., "Preliminary Design and Optimization of Steel Building Systems", Proceedings, ASCE-IABSE International Conference on Tall Buildings, Vol. 2, Lehigh Univ., 1972, pp. 185-201.
- Joseph, L.M., C. H. Thornton and U. Hungspruke, 1997, "Design of World's Tallest Building - Petronas Twin Towers at Kuala Lumpur City Centre" The Structural Design of Tall Buildings, Vol. 10 p.9-26.

- Kamath, Kiran and Divya, N and Rao, Asha Udaya (2012) "Performance Analysis of outrigger structural systems for Tall Building", proceedings of National conference on Advanced Trends in Civil Engineering, Karpagam University.
- Katz, P., Robertson, L. E., and See, S. (2008). "Case Study: Shanghai World Financial Center." *CTBUH Journal*, (II), 10-14.
- Lame, A., "Optimization of Outrigger Structures", MEng. Thesis, Massachusetts Institute of Technology, June 2008.
- McNamara, R. J. (2005). "Some Current Trends in High Rise Structural Design: Mixed Systems and Irregular Load Paths." *Structure Magazine*, (September), 19-23.
- Nair, R. S., "Belt Trusses and Basements as "Virtual" Outriggers for Tall Buildings", *Engineering Journal*, AISC, Fourth Quarter, Vol. 35, No. 4, p. 140-146, 1998.
- Paul H K HO 2007 Economics Planning of Super Tall Buildings in Asia Pacific Cities, Hong Kong SAR, China.
- Po, S., Siahaan, F. "The Use of Outrigger and Belt Truss System for High-rise Concrete Buildings", *Dimensi Teknik Sipil*, vol. 3, no. 1, 2001, p.36-40.
- P.S. Kian and F.T. Siahaan, "The use of outrigger and belt truss system for high-rise concrete buildings". *Dimensi Teknit Sipil*, Volume 3, No1, 2001.
- SAP2000, 2011, "Integrated Solution for Structural Analysis&Design", Version 15, Computers&Structures Inc., California, USA.
- Sarkisian, M. (2011). "Practical Limits of Structural Systems." *Designing Tall Buildings: Structure as Architecture*, Routledge, New York, NY, 92.
- Scarangelo, T., Krall, K. and Callow, J. (2008) "A Statement in Steel." Proc. CTBUH 8th World Congress.

- Schueller, W., "High-Rise Building Structures", John & Wiley Sons Inc., New York, 1977.
- Shieh, S. S., C. C. Chang, and J. H. Jong, 2003: Structure design of composite super-columns for the TAIPEI 101 Tower. Proceeding of International workshop on steel and concrete composite constructions, National Center for Research on Earthquake Engineering of Taiwan, 8-9 October 2003, 25-33.
- Simiu, E., and Scanlan, R., "Wind Effect on Structures: An Introduction to Wind Engineering", John & Wiley Sons Inc., New York, 1986.
- Smith, B. S., Cruvellier, M., Nollet, M-J., and Mahyari, A. T., "Offset Outrigger Concepts for Tall Building Structures." Tall Building Structure-A World View. In Proceedings of 67th Regional Conference in Conjunction with ASCE Structures Congress XIV.15-18 April 1996, Chicago, Illinois, USA. Bethlehem, Pa: Council on Tall Building and Urban Habitat, Lehigh University.
- Smith, B. S. and Salim, I., "Parameter study of outrigger-braced tall building structures", Journal of the Structural Division, Vol. 107, No. 10, (1981), 2001-2014.
- Stafford Smith B, I. S. (1981). Parameter study of outrigger braced tall building structures. American Society of Civil Engineers.
- Taranath, B., "Steel, Concrete and Composite Design of Tall Buildings." McGraw Hill, Texas, 1988.
- Taranath, Bungale S, "Steel, concrete, and composite design of tall buildings", Second edition, McGraw-Hill, (1998)
- Taranath, B., "Optimum belt truss location for high-rise structures", Structural Engineer, Vol. 53, No. 8, (1975), 18-21.

- Taranath, B. S. (2012). "Structural Analysis and Design of Tall Buildings". CRC Press, Boca Raton, FL.
- Tek, A., B. Oğuzhan and H. Karsan, 1993, "Ankara, İstanbul ve İzmir İlleri için Rüzgar Yükleri", Türkiye Ulusal Jeodezi-Jeofizik Birliği Genel Kurulu Bildiri Kitabı, Ankara.
- Tomasetti, P., Hsiao (2001) "The Tallest Concrete Building 246 Hi Sun Choi and Leonard Joseph | International Journal of High-Rise Buildings in Shanghai, China – Plaza 66." Proc. Tall Buildings and Urban Habitat – Cities in the Third Millennium, CTBUH.
- Turkish Earthquake Code, TEC, 2007, Specification for Structures to be Built in Disaster Areas, Ministry of Public Works and Settlement, Government of Republic of Turkey.
- Wada, A., "How to Reduce Drift of Buildings", ATC-15-3 Proceedings of Fourth US-Japan Workshop on the Improvement of Building Structural Design and Construction Practice. Applied Technology Council: Redwood City, USA, p. 349-365.
- Wu, J. and Li, Q., "Structural performance of multi-outrigger-braced tall buildings", The Structural Design of Tall and Special Buildings, Vol. 12, No. 2, (2003), 155-176.
- Zils, J., and Viise, J. (2003). "An Introduction to High-Rise Design." *Structure Magazine*, (November), 12-16.
- Zhang Jie, Zhang Zhong-xian, Zhao Wen-guang, Zhu Hong-ping, Zhou Chun-sheng, (2006), "Safety Analysis of Optimal Outriggers Location in High-rise Building Structures", Department of Civil Engineering and Mechanics, Huazhong University of Science and Technology, Wuhan 430074, China.