

FOR REFERENCE

NOT TO BE TAKEN FROM THIS ROOM

MICROPROCESSOR BASED DC CHOPPER DRIVE  
FOR ELECTRIC TRACTION

by

Metin AKAY

B.S. in E.E., Boğaziçi University, 1981

Submitted to the Institute for Graduate Studies in  
Science and Engineering in partial fulfillment of  
the requirements for the degree of  
Master of Science  
in  
Electrical Engineering

Bogazici University Library



39001100315004

14

Boğaziçi University

1984

To YASEMİN and R. ALTUĞ

## ACKNOWLEDGEMENTS

I am grateful to Dr. Ömer Cerid for his guidance and helps till the beginning of the thesis, and his cooperation in our obstinate work to realize the system.

I would like to appreciate the patience of my family during the design and realization of the thesis.

I also would like to express my thanks to Dr. Ahmet Denker who gave me some idea for the thesis, Mustafa Niksarlı, Semih Bingöl, Cüneyt Gemicioğlu, Fatih Çolgar for their encouragement in our late works, and Cemal Yamalıoğlu for the typing of the manuscript.

## ABSTRACT

In this thesis a microprocessor based DC chopper drive for electric vehicles is designed and implemented. The DC motor is fed by a two-quadrant chopper, the firing pulse of which is set directly by the microcomputer. The system is centered around a MC6802 microprocessor. Attention here is focused upon the motoring and regenerative braking of a DC motor. The PID (Proportional-Integral-Derivative) algorithm implemented in the microcomputer, acts on the error to result in the digital control pulses to drive the choppers. In the last two chapters, in addition to these, the experimental results are analyzed and system performance is evaluated. Further suggestions for improvement are given.

## ÖZETÇE

Bu tezde elektrikli taşıt araçları için mikroişlemci kullanarak bir DC kıyıcı-sürücü dizge tasarımlanmış ve gerçekleştirilmiştir.

Doğru akım motoru, ateşleme darbeleri mikrobilgisayar tarafından denetlenen iki kadranlı bir kıyıcı ile sürülmektedir. Denetleyici bir MC6802 mikroişlemci etrafına kurulmuştur. Burada ilgi, doğru akım motorunun motorlama ve rejeneratif frenlemesi üzerine yoğunlaştırılmıştır. Mikroişlemcide gerçekleştirilen oransal-tümlevsel-türevsel algoritma yanılıgı sinyalinı algılayarak, kıyıcıyı süren sayısal denetim darbelerini ayarlar. Ayrıca, tezin deneysel sonuçları incelenmiş ve dizgenin performansı irdelenerek dizgenin geliştirilmesi için öneriler sıralanmıştır.

## TABLE OF CONTENTS

	<u>Page</u>
ACKNOWLEDGEMENTS .....	iii
ABSTRACT .....	iv
ÖZETÇE .....	v
TABLE OF CONTENTS .....	vi
CHAPTER 1	
Introduction .....	1
CHAPTER 2	
Electric/Hybrid Vehicle Traction Drive .....	27
2.1 Wound field DC motors .....	29
2.2 Permanent magnet (PM) DC motors .....	31
2.3 Control methods of a separately excited DC motor .....	33
CHAPTER 3	
DC Chopper Drives .....	37
3.1 Principles of chopper operation .....	37
3.2 Two quadrant type A chopper .....	40
CHAPTER 4	
Microprocessor Based Speed Control System For a Separately Excited DC Motor .....	43
4.1 Description of the system .....	43
4.2 System Software .....	63
CHAPTER 5	
System Evaluation and Experimental Results .....	67
CHAPTER 6	
Conclusions and Further Improvements .....	74
REFERENCES .....	75
APPENDIX .....	76

CHAPTER 1  
INTRODUCTION

Estimates of the world's recoverable oil reserves vary, but it is generally expected that by the end of the 20<sup>th</sup> century the world's oil is likely to be a very expensive commodity. This has led many countries to search ways of reducing dependence on supplies of oil and to conserve domestic supplies. Before discussing the new management concepts it is important to consider the conventional standard vehicle power plant and drive system characteristics. Let us first examine driving in the city over the EPA/FUDC (Federal Urban Driving Cycle). It has a range of 17.65 miles and takes 35.6 minutes to complete this range. In a standard automobile it is found that fuel is consumed continuously over a 20 minute period (Ref. 1). Part of this fuel is used to propel the vehicle, that is, to overcome the road load (about 2.5 hp on the average), part of it is used to keep the engine idling at stops and part of the fuel is used to decelerate the vehicle when the driver depresses the brake pedal. The approximate amount of fuel used for each of these modes in city driving is shown in Table 1.A.

Table 1.A Fuel Utilization Over EPA/FUDC for Standard Vehicles

<u>Mode</u>	<u>Fuel (gms/7.5 mi)</u>	<u>Percent</u>
Road load	377	44
Brakes	259	30
Idle	113	13
Other	113	13
Total	861	100

Clearly, to achieve the best fuel economy in the city in conventional cars, it is necessary to 1) eliminate or minimize idle and deceleration fuel, 2) make an engine operate at high efficiency at very low power levels, and 3) recover energy from braking. Items 1 and 2 could be accomplished by designing an engine with a wider range efficiency characteristics. Item 3 cannot be accomplished with a conventional vehicle.

The i.c.e. has a maximum efficiency of over 30 percent and an efficiency of over 25 percent for a large speed and power range. However, in normal stop-go driving its average efficiency will only range from 10 to 15 percent. This is because normally i.c.e.'s are sized to allow hill climbing without noticeable speed reduction, and for motorway travel. In stop-go driving the mean power required is low resulting in the engine being used at low efficiency, hence giving poor fuel consumption.

To achieve good fuel economy on the highway, it is simply to match the engine peak efficiency point with the road load at highway cruise speeds. For example, if the power required to cruise on a level road at 60 MPH is 20 hp and the engine operates most efficiently at a setting of 20 hp then directly gearing the engine to the drive wheels through the proper ratio will provide the best possible mileage than one could obtain. On the other hand, if the drive power is 20 hp as stated but the best efficiency is produced with the engine running at 40 hp then a flywheel which will be illustrated later, can be used to load level the system operating "on" half of the time and "off" the other half time. Thus the need for a flywheel during highway cruise is dependent upon the engine size than one is working with. For example, if the flywheel handling the high power peaks and the small engine needing only to supply the average power over the cycle, this concept can work in flat areas, but would cause poor perfor-

mance on long hills unless a very large flywheel were used. This will also introduce important problems.

The conventional ICE accounts for the major contribution to air pollution caused by automobiles, it is natural that the processes of pollutant formation in this engine have been studied much more extensively than those in any other types of engine.

The major pollutants in the conventional ICE exhaust are unburned hydrocarbons (HC), carbon monoxide (CO), and oxides of nitrogen ( $\text{NO}_x$ ).

Fig. 1.1 shows a set of curves which are widely quoted in discussions of pollutant formation in IC engines. It shows qualitatively how the levels of HC, CO and  $\text{NO}_x$  in the exhaust are related to the air-fuel ratio employed in the engine. Carbon monoxide resulting from incomplete combustion of the engine, is seen to increase on the "rich" side of the stoichiometric mixture. Conversely, CO decreases with "lean" mixtures where excess oxygen is available to promote complete combustion of the fuel.

Oxides of nitrogen are formed by high temperature non-equilibrium reactions involving the nitrogen and the oxygen in the air. Given sufficient time at the higher temperatures of combustion, further reactions would remove the  $\text{NO}_x$  and CO from the products of combustion. However, in actual operation these further reactions are "frozen" by the falling temperature of combustion during the expansion stroke. These occur because the rate constants of the reactions concerned vary widely, and are temperature dependent.

Control strategies which have been developed to control exhaust emission levels include the following ;

- 1) Operate at high (lean) air-fuel ratios. This is a highly desirable strategy since it simultaneously reduces CO and  $\text{NO}_x$  and improves engine efficiency. However, the extent to which this measure can be carried is limited by

the lean flammability limit of the fuel. It is perhaps worth mentioning here that a considerable extension of the lean flammability limit of gasoline/air mixtures can be achieved by means of hydrogen enrichment.

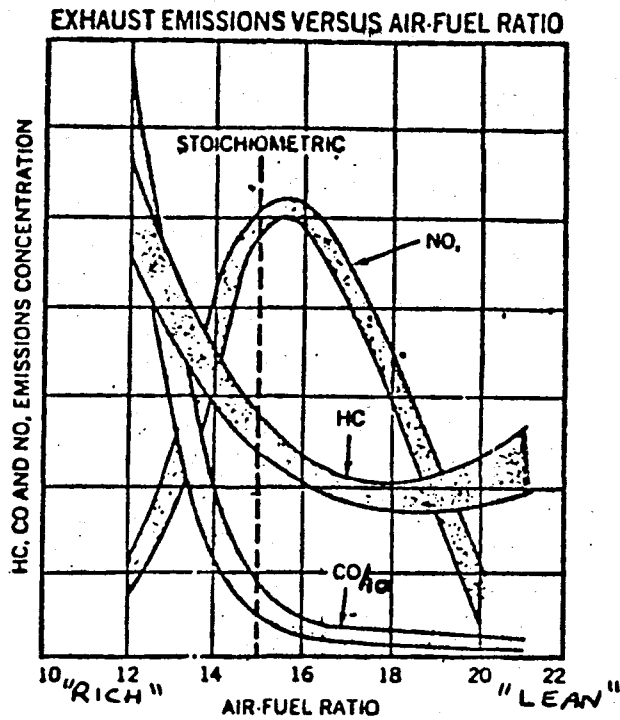

Figure 1.1 Exhaust Emissions Versus Air-Fuel Ratio

2) Retard the spark timing. This reduces the peak combustion temperature and thus reduces the formation of NO<sub>x</sub>.

3) Use exhaust gas recycling (EGR) to the engine inlet. This is used much currently. The fuel/air charge in the cylinder is diluted with exhaust gas and thus the peak combustion temperature is reduced. This can reduce NO<sub>x</sub> emissions considerably.

4) Catalytic converters in the exhaust line may be used to remove oxides of nitrogen and other pollutants.

Unfortunately, different catalytic reactions (reduction) are required to remove NO<sub>x</sub>, as compared to the oxidation

reactions which are required to remove CO and HC. Furthermore, lead-free fuel must be used to avoid catalyst poisoning and this leads to lower compression ratios in the engine with consequent reductions in fuel economy.

Figure 1.2a shows schematically a typical system for emission control, as fitted to production automobiles in 1975.

The system employs spark and exhaust gas recycling to reduce oxides of nitrogen, followed by an air pump and catalytic converter to oxidize CO and unburned HC. Control systems like this achieve typically an order of magnitude reduction in emissions of HC, CO and  $\text{NO}_x$  as compared to uncontrolled engine systems. However, the fuel economy (mpg) of the controlled vehicles is typically reduced by around 10% by the use of such techniques. More advanced proposals for emission are shown in figures 1.2b and 1.2c.

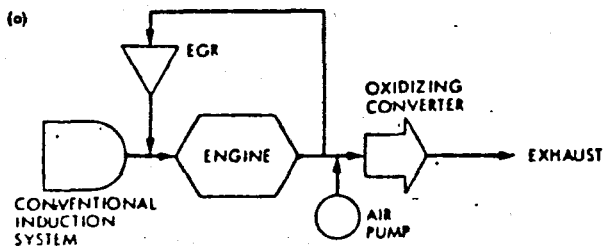

Figure 1.2a

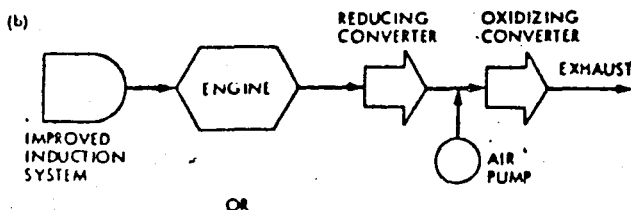

Figure 1.2b

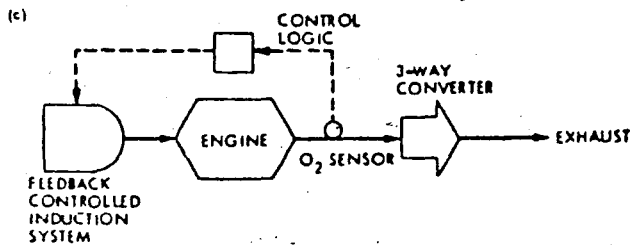

Figure 1.2c

At the first sight electric vehicles seem to offer a solution to the problems facing the conventional vehicle. They are quiet, do not cause pollution of the city centers and have the capability to reduce dependence on oil. Electric vehicles (EV) have a long history but their development was ignored for many years because of the greater flexibility and convenience of internal combustion engine vehicles (ICEV). In the decade of the 1970's, however, several factors led to renewed interest in EV on a worldwide scale.

The flexibility associated with the source of energy for electric vehicle contrasts with the operational flexibility of internal combustion engine vehicles. The primary operational differences between electric vehicles and internal combustion engine are in their energy storage characteristics. These include both mass and volumetric energy densities, the interdependence of power and available energy in batteries, and the limits on the battery service life. A closer consideration shows that the range and performance of electric vehicles is limited by the presently available energy source of the lead-acid battery.

Performance is an important consideration if electric and conventional vehicles are to be in use at the same time. The rate of flow of traffic lights and other junctions is determined by the slowest vehicle. At present, high performance can only be obtained at the cost of reducing range because the energy available from lead-acid batteries falls

as the rate of discharge is increased, as shown in figure 1.3.

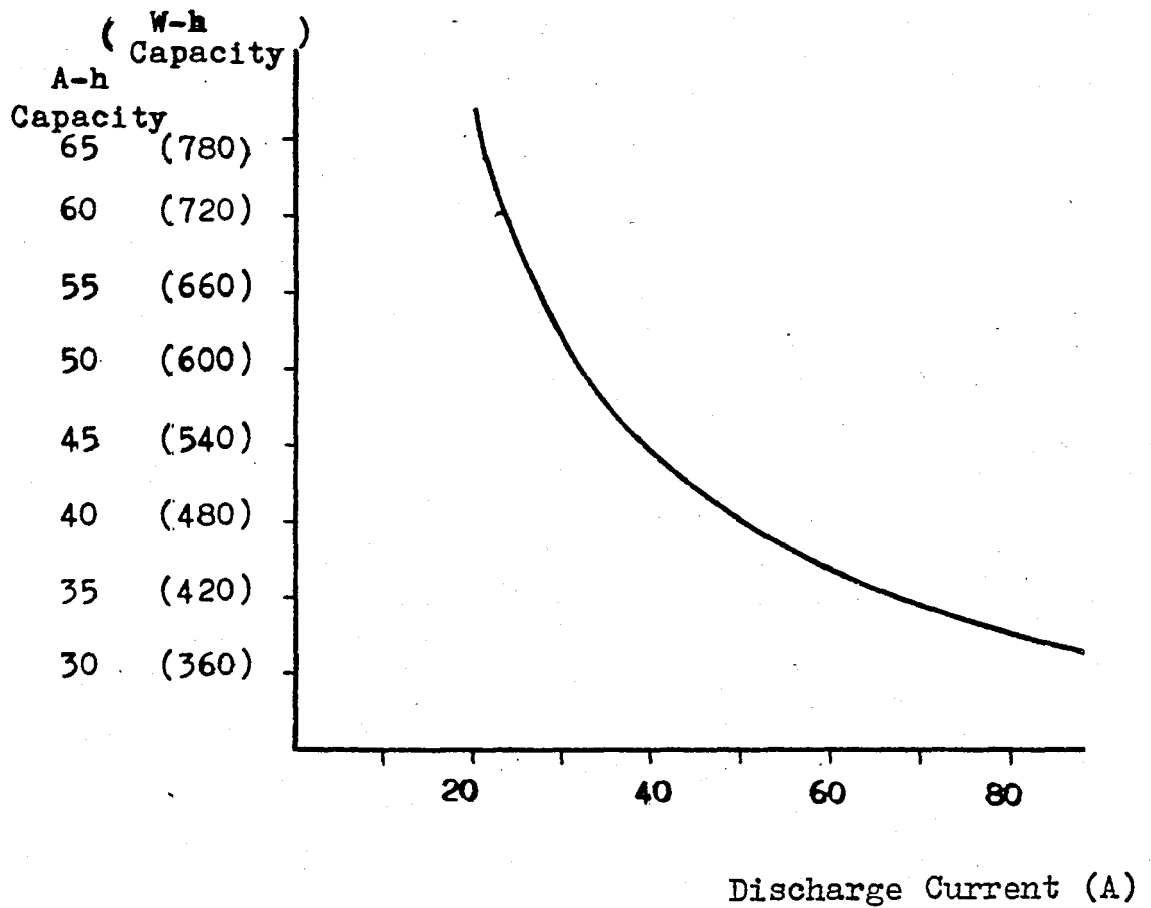

Figure 1.3 Capacity Versus Discharge of a Lead-Acid Battery

Table 1.B Comparison of lead-acid and zinc-chlorine batteries (Ref. 5)

	<u>Lead-Acid</u>	<u>Zinc-Chlorine</u>
Capacity	40 kWh	40 kWh
Weight	1136 kg	259 kg
Volume	0.97 m <sup>3</sup>	0.48 m <sup>3</sup>
Energy Density	35 Wh/kg	154 Wh/kg
Power Output (minute peak)	2 hrs	4 hrs
Cycle Life	300-3000	500-5000
Overall Efficiency	70 %	65 %
Estimated Cost	1,200	1,200

Range and performance of electric vehicles are related to the energy and power density of lead-acid batteries. At present high energy and power demands on a lead-acid battery result in low cycle life for the battery. The problem with batteries of all types is that their capacity to retain an initial charge diminishes with repeated charge/discharge cycling. The quality of a battery in this respect is measured in terms of its life cycle or cycles to failure "at a given" depth of discharge expressed as a percentage of the full battery ampere-hour capacity.

The generally accepted definition of "cycle life" of a battery is based on a standard SAE test, and corresponds to an inability of the battery to retain at least 80 % of the charge supplied to it at the end of its useful life. The cycle life is often quoted in terms of deep discharge cycles to failure, and these are generally taken to a depth of discharge of 70 to 80 % of full capacity. A typical value of cycle life for a lead-acid cell on this basis is approximately 250 deep discharge cycles (Ref. 2). This corresponds to only 12,000 to 15,000 miles between costly battery replacements.

It has been estimated that for an acceptable range batteries are required that have an energy density from 90 to 200 Wh/kg. At present the maximum energy density achieved by a lead-acid battery is the 50-60 Wh/kg of a prototype battery of the Matsushita Electric Company of Japan. A typical car starter battery has an energy density of 30 to 35 Wh/kg, but it will not withstand repeated deep discharge cycles. Traction batteries have a poorer energy density, 20 to 25 Wh/kg and are comparatively expensive, but they have a long life when subjected to deep discharges.

In spite of intensive research efforts, present day battery systems are not competitive with petroleum-based fuels in these respects. As a result, both the initial and cycle life costs of electric vehicle are expected to be higher than those of comparable internal combustion engine vehicle.

To obtain a range in the region of 60 to 100 km about 30 percent of the weight of an electric vehicle needs to be the weight of the batteries. If 6 percent of a conventional vehicle's weight is petrol it can have a range of 300 to 500 km. Also the conventional vehicle has the advantage that

it can be easily refueled. Further, it is the cost, size and weight of batteries which prohibits any significant increase in the installed energy in a vehicle, thus vehicle range is generally limited to 80-100 km.

A further problem with electric vehicles is heating in cold weather. A conventional car uses the waste heat from the internal combustion engine (i.c.e.) for vehicle heating, electric vehicles have to carry a separate supply of fuel for heating. For a six seater family car lighting, windscreen wipers, clock, radio and ventilation systems combined require approximately 270 W and power steering would require a further 500 W and air conditioning, if used, has an average 3.5 kW.

So far the electric vehicle has only been considered with lead-acid batteries as the energy source. Figure 1.4 shows typical efficiencies for the power supply and transmission elements which are associated with an electric vehicle, and it is seen that the overall efficiency of the system depends heavily on the efficiencies of the energy storage system, controller and motor which is employed.

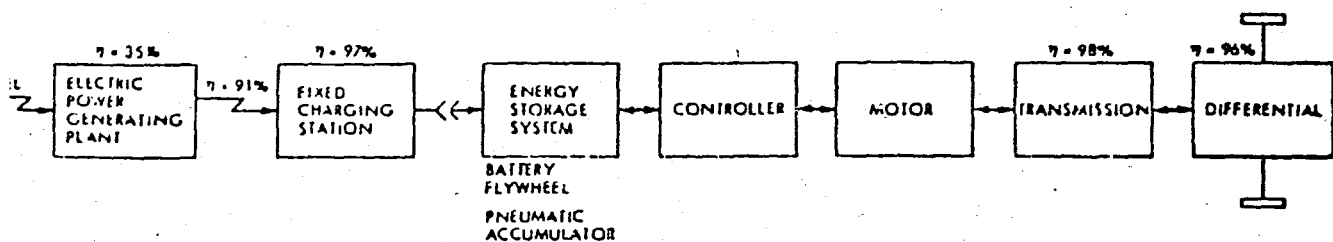

Figure 1.4

In the long term alternative batteries will be developed that will make electric vehicle more attractive. The most promising recent battery development has been that announced by Energy Development Associates concerning their zinc-chlorine battery. A comparison of the lead-acid and zinc-chlorine batteries is given in table 1.B. A model car with a 45 kWh zinc-chlorine battery achieved a range of 240 km at 88 km/hr. Also there is the possibility of the development of fuel cells that will supply the electricity in the electric vehicles. Fuel cells require use of expensive materials, high operating and have a low cycle life.

Possibly the most encourageing news for electric vehicle proponents was the recent announcement by the General Motors Corporation that they expect to have a production electric car on the road by 1985. This vehicle will probably be powered by zinc-nickel oxide batteries. GM have said they expect "reasonable cycle life and replacement cost for the batteries" giving the car a top speed of 80 km/hr and a range of 160 km between charges.

Hybrid vehicles can be built to reduce the fuel consumption or pollution of conventional vehicles or to improve the range of electric vehicles. Whichever view of hybrids is adopted they should only be regarded as a stepping store to the day when light performance electric vehicles can be produced. Manufacture of certain hybrid vehicles will allow a gradual change over in manufacturing processes. As progress is made these hybrids will be built with smaller engines and will use batteries of gradually increasing capacity.

Before a more detailed study of electric/hybrids is undertaken, it must be remembered that the performance of the i.c.e. is being continually improved.

The otto spark ignition engine has been in a continual state of development for the last 50 to 60 years. During this

time a complex supply and maintenance infrastructure has been built up. Improvements today have been mainly in improving the power to weight ratio which is now around 0.5 kW/kg. High octane fuels have led to fuel economy improvements higher compression ratios.

The fuel economy of i.c.e.'s can be improved by

1. Changes in engine design,
2. More efficient engine use. Cylinder disabling can improve engine efficiency when the road load is less than the maximum the engine can produce,
3. Use of alternative fuels or fuels with certain additives, e.g. gashol, popular in the USA where alcohol is added to the petrol,
4. Improvements in transmission. The losses in the automatic gearbox commonly used in the USA are much higher than for a manual four speed gearbox. The advent of a commercially available continuously variable transmission (c.v.t.) will enable the engine to provide the power required at the optimum engine speed to minimize fuel consumption,
5. Reducing vehicle aerodynamic drag,
6. Improvements in carburation.

In this section, different possible vehicle configurations, components and the objectives of the vehicles are expressed. Most passenger cars in use today have an otto spark ignition engine, alternative engines and fuels that could be used in future hybrid and conventional vehicles can be utilized in certain hybrid vehicles to maintain any advantages they may have. Some developments may have operative difficulties that can be more easily overcome in a hybrid vehicle, for example, the use of a Brayton engine.

### 1.1 Electric Vehicles

The equation used for the efficiency of hybrid vehicles

can be modified to consider electric vehicles (Ref. 3). Energy consumption per mile =  $E_w / (EFF_b \cdot EFF_m \cdot EFF_{pt} \cdot EFF_c)$  where  $E_w$  is the energy required at the road wheels,  $EFF_b$ ,  $EFF_m$ ,  $EFF_c$  and  $EFF_{pt}$  are the battery, motor, controller and transmission efficiencies respectively.

Whatever vehicle is being considered maximizing  $EFF_b$ ,  $EFF_c$ ,  $EFF_m$  and  $EFF_{pt}$  and minimizing  $E_w$  are the only methods of reducing energy consumption. One obvious way in which the electric vehicle is more efficient than the conventional vehicle is that it does not consume fuel while stationary. Many present electric vehicles have their electric motor directly geared to the road wheels. Using a gearbox will increase the efficiency of the motor at low vehicle speeds. The torque at low speed of a series DC motor is superior to that of an i.c.e. with a similar rated power output even without the use of a gearbox. However, the current required to produce the high torques is correspondingly high. As was shown in figure 1.3, the capacity of lead-acid batteries falls with increase in discharge current therefore, the use of a gearbox enables the range of the electric vehicle to be extended by reducing the size of the starting current. Since battery efficiency is high at low discharge rates but low at high discharge rates a gearbox will help maximize  $EFF_b$ , at the price of a small increase in  $E_w$ .

## 1.2 Hybrid Vehicles

Hybrid vehicles are powered by two or more energy sources. Using more than one energy source at first appears an expensive and complex alternative to the conventional vehicle. By looking at the merits of the i.c.e. and electric vehicles and by careful selection of hybrid arrangement and operating philosophy the advantages of the different drives can be maximized whilst restricting their disadvantages.

Hybrids offer the possibility of regenerative braking which a conventional vehicle can not. It was mentioned that the i.c.e. is capable of greater efficiency that is obtained in normal stop-go driving, the hybrid offers the opportunity to improve the overall efficiency of the i.c.e. Consequently the greatest benefits from hybrids occur in urban driving. Driving at constant speed in a hybrid will require more fuel than a conventional vehicle, if the hybrid is heavier than the equivalent conventional vehicle as the second energy source does not assist in constant speed operation. A hybrid can allow the engine to be switched off during overrun while the vehicle is stationary. It has been shown that this could save up to 20 percent of the fuel consumed when using CVT (Ref. 3).

Hybrids can have several goals, for example, reduction of fuel consumption, minimization of air pollution, improved acceleration or noise reduction. Generally, it is not possible to achieve more than one of these in any one vehicle. Attempts to incorporate all of them into one vehicle have generally resulted in failure to achieve any of them. It must also be remembered that while certain control schemes may benefit a particular class of vehicle these improvements will not necessarily apply to all classes of vehicle. Generally, good vehicles obtain greater benefit from a hybrid power train than cars; room for the extra energy store and the extra weight represents a smaller percentage increase in vehicle weight than for a car. Busses also stand to gain a great deal by being converted to hybrids because when used in city centers their frequent stop-start operation means that up to 2/3 of the energy used is available for recovery when braking.

Hybrid vehicle configurations can be classified as either series or parallel hybrids, depending on the power flow path to the final drive unit. In the series system the energy sources are combined so that consecutive energy occur along

one of the power paths to the final drive. By contrast, in the parallel hybrid system the power units are each mechanically coupled to the drive wheels. The configuration is illustrated in figure 1.5 for a battery flywheel hybrid.

The complexity of hybrid drive trains compared with a conventional electric transmission can be readily appreciated from the systems depicted in figure 1.5. A comparison of the three systems explains the current preference in some areas for series hybrids because these avoid the need for a continuously variable transmission (CVT). Series hybrids are, however, inherently less efficient than parallel hybrid configurations because of the increased number of energy transformations between the storage elements and the drive wheels.

The two systems shown in figures 1.5 and 1.6 require a motor controller. These units are frequently sources of system malfunctioning and may also be a significant contributor to energy losses. Thus the system shown in figure 1.7 is potentially more reliable and offers better efficiency than the system shown in figure 1.6, even though in the latter case only a part of the power flows through the CVT. Moreover the system in figure 1.6 requires both a motor controller for the CVT and this added complexity and cost are unacceptable. The system shown in figure 1.7 dispenses with a motor controller, because a compound-wound unit is used with the characteristics matched to the road load. Thus the power for accelerating and hill climbing together with the provision of regenerative braking, are supplied by the flywheel and the complete system is controlled through the CVT.

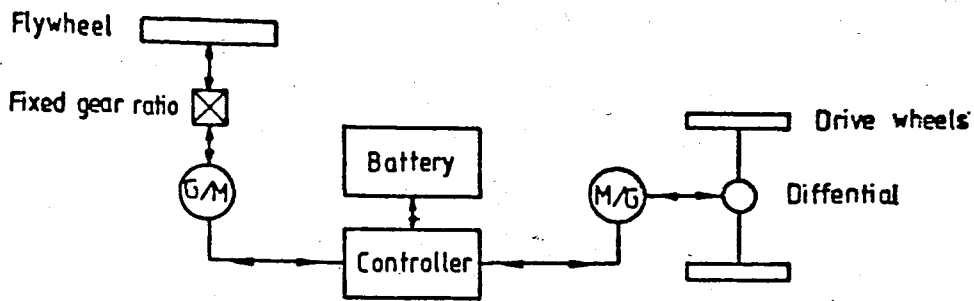

Figure 1.5 Series Hybrid Configuration

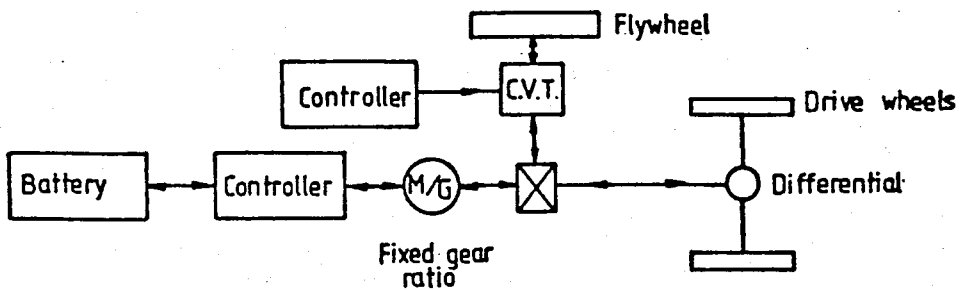

Figure 1.6 Parallel Hybrid Configuration

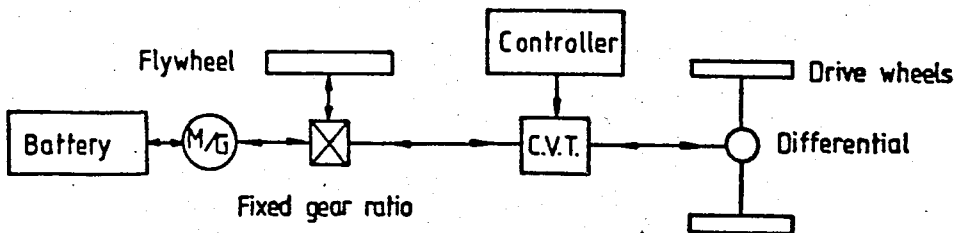

Figure 1.7 Sussex Parallel Hybrid Configuration  
Denotes energy exchange M: motor, G: generator

SOME HYBRID CONFIGURATIONS

### 1.3 Flywheel

Hybrids can be considered for extending the range and power capability of purely electric vehicles. These vehicles would have a single energy source, mains supplies electricity. The type of considered in this category would be battery-ICE, battery-fuel cell, battery-battery and battery-flywheel. Each of these has specific merit; the first two primarily address range extension and the latter two power augmentation. However, because of the interrelationship of battery power and available energy, power augmentation can also result in range extension. Furthermore, reduced peak-power demands may also result in prolonged battery life.

The need to improve the performance (power) and extend the range of electric vehicles, coupled with increased battery life are the basis for electric vehicle related flywheel technology efforts.

Flywheels have been used for many years to supply peak power for many industrial machines. They can be used in a similar energy source. With regard to electric vehicles, a considerable potential exists for range extension, performance improvement and increased battery life, through the regeneration of braking energy and load-leveling capability of flywheel systems.

The mass energy density (Wh/kg) of various types of flywheel is comparable to that achieved by modern lead-acid batteries, but the power density (W/kg) of flywheels is limited for practical purposes, only by the strength of the related hub, shafts and gears. This capability to transmit power makes flywheels ideal candidates for complementing a battery system in meeting the peak loads during acceleration, braking and travel on inclines.

It should be noted that the improvement resulting from the recovery of braking energy is directly related to the number of stops and starts per kilometre; thus, operation in

an urban environment is a definite advantage.

Although flywheels offer the promise of improved performance and energy efficiency, they also add to the complexity of the drive train and control systems. In addition to the obvious advantages associated with performance and range, a hybrid vehicle incorporating regenerative braking may decrease maintenance costs.

It is difficult to place an economic value on the extended range of an electric vehicle, but some studies suggest that this should be at least equivalent to the lifetime costs of the additional batteries which would otherwise be needed for the range of extension.

The promise of increased battery life may be the most significant economic factor affecting the use of flywheels in electric vehicles, since a) the cycle life of present day batteries is seriously limited and b) the cost of the battery system is a major element in both the initial and life-cycle cost of the vehicle. If the flywheel could extend the life of the batteries by one third, the lifetime cost of the EV would be substantially reduced.

While increased range and extended battery performance can be objectively evaluated, the marketability of improved performance, in terms acceleration, hill climbing and high speed passing is less tangible.

Energy storage in high speed flywheels is widely regarded as a serious possibility for the replacement or augmentation of other forms of energy storage in automobiles. Very high power density, typically of the order of 10 kW/kg and "modest" energy density, comparable with that of the Lead-acid battery are the main currently achievable characteristics of practical flywheel systems.

The advent of fibre-reinforced composite materials has generated a great deal of optimism concerning the potential for substantially increased energy density in future flywheels.

The theoretical maximum energy that can be stored by a flywheel per unit weight depends on the ratio of strength to density of the material from which it is constructed :

$$\left(\frac{E}{W}\right)_{\max} = 0.0314 \cdot K_w \cdot \frac{\sigma}{\rho}$$

Here,

$\frac{E}{W}$  is the energy density in watt hours /lb

$K_w$  is a "shape factor" depending on the shape of the flywheel

$\sigma$  is the material working stress in  $K_{\text{psi}}$  (tensile)

$\rho$  is the material weight density in  $\text{lb/in}^3$

A "volumetric specific energy" may also be defined by

$$\left(\frac{E}{V}\right)_{\max} = 0.0542 \cdot K_v \cdot \sigma$$

where

$\frac{E}{V}$  is the energy stored (kWh) per unit volume of the cylinder enclosing the flywheel's maximum axial length and its maximum radial dimension ( $\text{ft}^3$ )

$K_v$  is "volumetric shape factor", for the flywheel  $\sigma$  is the working stress, as previously defined in  $K_{\text{psi}}$ .

#### 1.4 Hydraulic Accumulators

Compared with other modes of energy storage, the technique of storing automatic energy in a compressed gas appears to have been relatively neglected. The compressed gas is not the only working fluid, but is used to pressurise a hydrostatic power transmission system using hydraulic working fluid. Hydraulic accumulator systems have evolved generally into three main types : the bag type, the piston type and the diaphragm type, which is of relatively little interest in this thesis and is not shown.

Characterisation of an accumulator as an automotive energy store requires :

- 1) Study of relationships between pressures, flows and energy losses over automotive duty cycles.
- 2) Evaluation of energy and power density attributes.
- 3) Safety analysis and optimisation of control systems.

The energy and power densities of accumulators are not well characterised generally, and further work is required in this area. The main component of weight appears to be in the tankage required to contain substantial volumes of high pressure gas and hydraulic fluid. Using fibre-reinforced composites reduce accumulator weight and increase working pressures, achieve higher values of energy density.

The achievable power density of high pressure hydraulics is known to be good, but gain it is not well defined in relation to the automotive application.

This is recommended as an area for further study.

In terms of their achievable density of energy storage, combustible fuels are clearly superior to the available alternatives for the purposes of automobile propulsion. Methanol (in the near term) and hydrogen (in the long term) appear attractive as alternatives to petroleum-based fuels. In each case, however, on-board fuel storage capacity is likely to be significantly inferior to that of a conventional gasoline engine. A premium quality of future engines is likely to lie in their tolerance of a broad variety of fuel characteristics.

Advanced electric batteries or fuel cells are likely to achieve only modest energy densities (as compared to gasoline) and very poor power density.

Flywheel energy storage has little to offer with regard to energy density (as compared to expectations for advanced batteries), but can offer power densities which are superior to all other known modes of energy storage. Parasitic energy losses (such as windage and bearing (seal friction)) are likely to cause problems and safe design and operating procedures have yet to be evolved for flywheel systems.

Hydraulic accumulator systems are generally held to be " unpromising " on the grounds of their low energy density.

However, it is suggested that the overall potential and characteristics of such systems ( together with their associated energy conversion systems ) have not yet been evaluated properly. There appears to be scope for significant research in this area.

## 1.5 Power Transmission

As noted earlier, a continuously variable transmission is needed to match the flywheel to the final drive unit in a parallel hybrid configuration. To be effective the ( CVT ) must be of wide ratio and easily controlled, it must have a high efficiency and a bidirectional torque capability to allow regenerative braking. In addition, the device must be compact, lightweighted, quiet, reliable and available price. Some CVT types are shown in figure 1.8.

### 1.5.a Variable Ratio Belt - Drive CVT

A number of different belt drives have been designed. They have the distinction of being the only CVT fitted as a standard transmission in a mass-produced cars. It was predicted that V-belt drives have a higher power density and a higher efficiency than traction drives. Thus, there has been intensive research activity on the structure of the V-belt to overcome the power limitations of rubber belts. Metal V-chain drives have a higher power rating, but, they are noisy and are prone to erratic running. More recently extensive efforts have been devoted to metal V-belt (MVB) drives, but the fundamental principles underlying MVB's were initially incorporated in a patent granted in 1911. These belts offer the possibility of transmitting for higher power than rubber belts, thereby extending their useful range of application. In order to be suitable for heavy goods vehicles and bus transmissions, they must transmit 250-300 Kw or be used as an element in a split power drive.

### 1.5.b Traction-Drive CVT

Several designs of a rolling traction drive CVT have been proposed. The primary source of concern with these transmissions is the wear due to high contact stresses between the rolling elements. These problems have been successfully overcome in the Perbury Transmission, because complete separation of the rolling surfaces by a fluid film ensures that neither roller nor disc wear is a significant factor determining the life of the unit.

The efficiency of the Perbury unit is a function of its size ; at high power levels the losses due to bearing, seals and oil pump etc. Become less significant.

One of the earliest CVT concepts was a cone-roller configuration. A recent design study in the U. S. includes a differential-drive to expand the ratio range of the transmission and a microprocessor control of the cone-to-roller. These criteria provide a framework for evaluating the variety of transmissions that have been under investigation for some time.

### 1.5.c Hydromechanical CVT

The attraction of a hydromechanical CVT is that variable displacement pump and motor units are commercially available. However, poor part-load efficiency and high noise levels have limited their application in vehicles. In some applications noise is less of a disadvantage and several manufacturers are known to be interested in hydrostatic transmissions for heavy goods vehicles and buses. Research is also in progress to reduce the noise levels and increase the overall efficiency of the basic units.

Split-power hydrostatic transmissions can be used in conjunction with either hydraulic accumulators or flywheel energy storage units. The cost of the arrangement is likely to be competitive with electrical transmissions which require expensive controllers. When properly engineered, the units are compact and very reliable, but the problem of noise still remains to be overcome.

#### 1.5.d Electromechanical CVT

In this CVT, two motor-generators are mechanically coupled to a planetary-gear differential ; one is coupled to the ring gear and the other to the planet carrier, or output gear. In addition, the two are electrically coupled together. Under heavy loading, most of the power flows through the more efficient mechanical system with the motor-generator set acting as a control. The separate motors-generators are used for vehicle reverse and cruise and for initially providing energy to the flywheel. The range of the electromechanical CVT is limited by the ratio range of the planetary drive unit traction interface. The microprocessor control is included to improve the CVT efficiency and fatigue life.

#### 1.5.e Electrical CVT

Electrical " transmissions " may be particularly applicable in providing a flywheel interface with EV propulsion systems, and several configurations have been studied. The concept features an AC induction motor for propulsion; power to the propulsion motor is provided either by a 96-volt battery pack or by the flywheel energy storage unit which uses a homopolar inductor motor-generator as the electrical CVT. A three phase inverter provides the necessary interface between the energy source ( battery or flywheel ) and the motor.

Electrical " transmission " have the inherent disadvantages of requiring several energy transformations in a complete charge-discharge cycle, but they do overcome the problems associated with sealing the rotor casing. The difficulties of maintaining a vacuum when the rotor containment boundary is crossed by a shaft rotating at high velocity are well known and have received much attention.

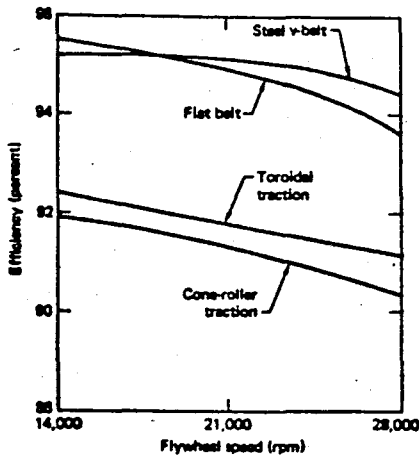

Figure 1.9 Comparison of CVT Efficiencies

The fuel economy of automobiles could be improved significantly by substituting 4-speed manual gearbox, or by developing wide-range automatic gearboxes with torque converter lock-up under cruise conditions. Such transmission modifications could be easily implemented on a fairly short time scale, but careful evaluation of effects on engine durability, noise, vibrations and emissions is needed beforehand and is in progress.

Continuously variable transmissions could yield even greater improvements in fuel economy with conventional engines, and constitute a vital component in certain advanced systems such as those employing single-shaft gas turbine engines, flywheel propulsion and certain hybrid drive configurations. More development efforts could be devoted to CVT's and to the study of related considerations such as engine durability and emissions.

The problems in existing electric drives are related to energy and power limitations in battery storage systems. Development effort related to flywheel could be rewarding in the short term, while development of a light, simple, highly

efficient traction motor such as the axial gap reluctance motor could repay the effort in the longer term. Despite considerable and continuing study, the potential capabilities of hybrid propulsion systems have still not been properly evaluated. More effort on simulation studies, including the development and evaluation of accurate and reliable models of system components for such studies is recommended.

In particular, the characteristics and potential of hydraulic accumulator energy storage and related power system components are not well established in a form suitable for automotive applications. This problem requires both theoretical and experimental work to develop and evaluate appropriate models.

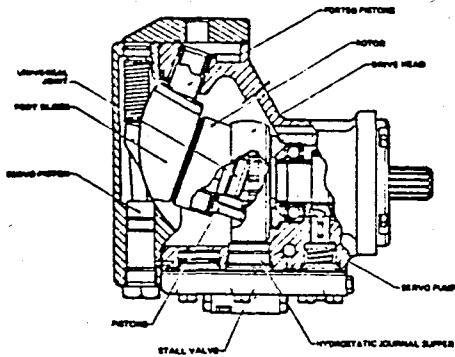

Fig 3.1 Ifield Pump/Motor for Hydrostatic CVT

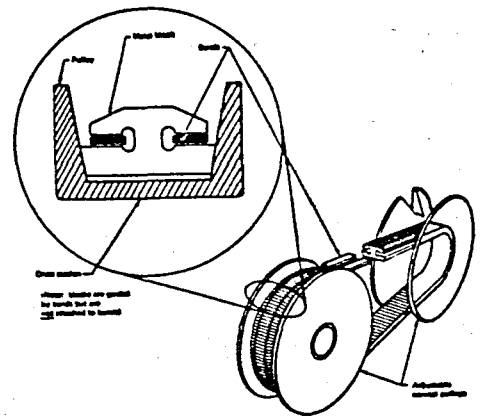

Fig 8.2 Steel Belt CVT

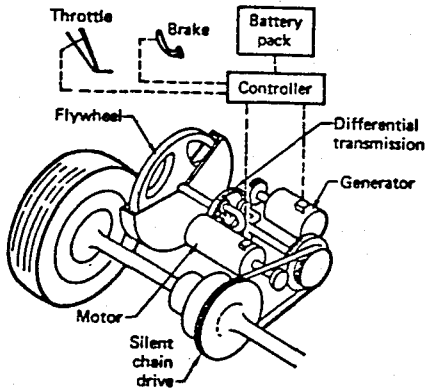
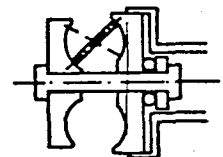
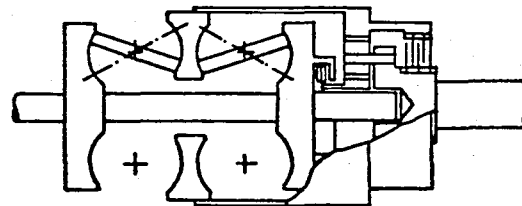

Fig. 8.3 Garrett Electromechanical CVT



9-1 Single roller set

CAPTION



9-2 Double roller set

Fig. 8.4 Perbury CVT

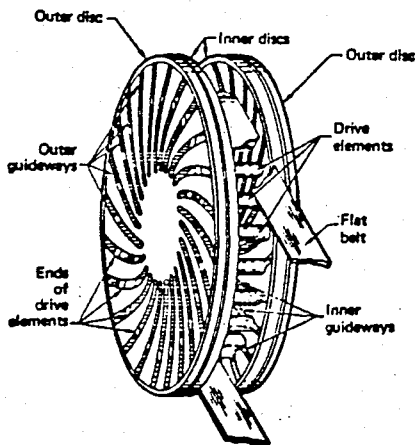

Fig. 8.5 Flat-belt CVT

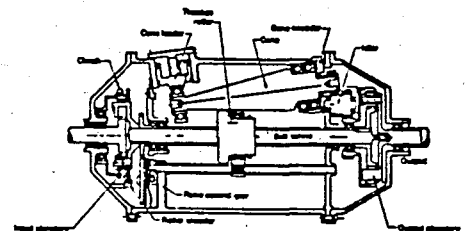

Fig 8.6 Cone-Roller CVT

## CHAPTER 2

### ELECTRIC/HYBRID VEHICLE TRACTION DRIVE TRAIN

Several EV related flywheel systems have been constructed and evaluated. The particular drive system is shown in figure 2.1 which incorporates a battery/motor combination together with a flywheel which acts as an auxiliary power source and is matched to the vehicle inertia through a single-sided Perbury CVT (Continuously variable transmission). With the presence of a Perbury CVT unit, providing continuously variable transmission to match the driving requirements to the motor and flywheel speeds under all operating conditions, the free running of the motor within the parameters of its maximum efficiency range was made possible.

The battery-motor-flywheel-CVT combination poses a number of unique control requirements. In contrast to conventional vehicles, speed control in such a configuration is maintained through CVT. This implies a control loop which entails three signals two of which are on-off commands and the third controlling the CVT. The implementation of these functions, however, calls for information processing capability and of necessity, involves microprocessors (Ref. 4)

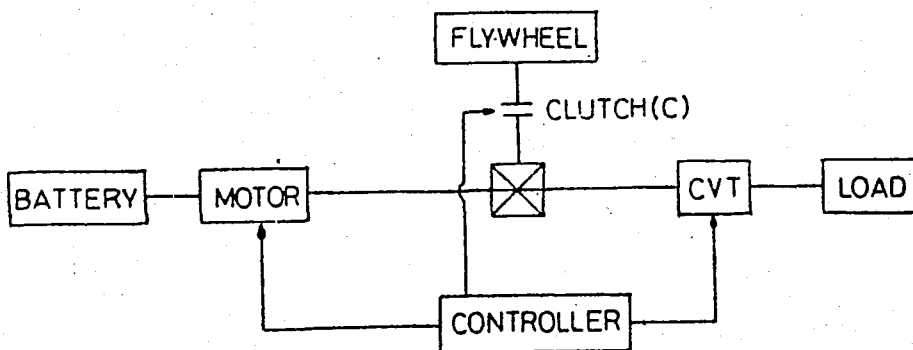

Figure 2.1 Schematic Diagram of the Drive System

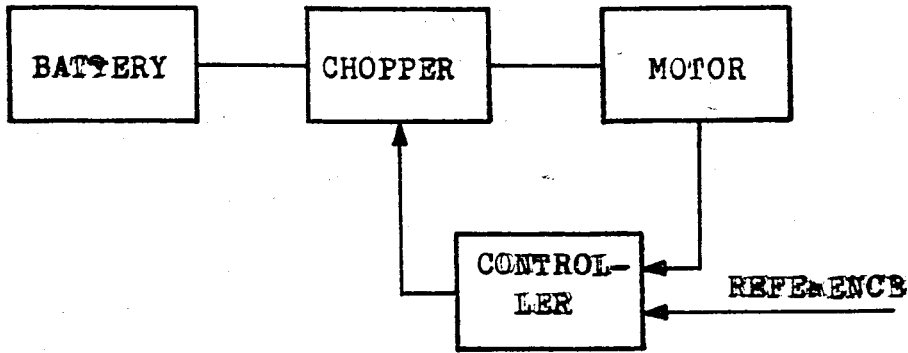

Figure 2.2

The attention here will be focused upon part of entire system. The circuitry considered here is shown in figure 2.2. It is aimed to design and control a battery/DC motor combination. The controller should provide operation in the motoring and regenerative braking mode where the microprocessor has the responsibility of the decision making. Error signal is formed according to deviation. The electric power is converted into mechanical power during motoring mode (acceleration and steady run) and back to electric during regenerative braking mode (deceleration) by using DC drives. In this way, with a proper transmission it should be possible to add excess energy of DC motor back into the battery, if the speed of the DC motor exceeds the reference speed.

The direct current (DC) motor which is one of the first machines devised to convert electrical power into mechanical power is used to drive electric vehicles. The ease with the DC motor lends itself to speed control has long been recognised. The versatile control characteristics of DC motors have contributed to their extensive use in industry. DC motors can provide high starting torque, and their speed variation range is large both above and below the rated speed. In addition, it is fed by DC source or battery.

The speed control methods of DC motors are simpler and cheaper than AC motors. Although commutators prohibit their use in some industrial applications, DC motors play a significant role in many industrial drives and are the dominant means of providing a controllable source of mechanical rotating power in industry. These advantages over AC type form the primary reason for using a DC motor in the vehicles drive.

There are two large families of DC motors, the integral horsepower types having power ratings of one horsepower or more and the fractional horsepower motors with power ratings of less than one horsepower (Ref. 5)

The class of fractional horsepower DC motors which utilize electromagnets to generate the stator magnetic field are called wound-field motors. The electromagnets can be energized individually or in conjunction with the armature, the motors are known as self-excited motors. Various configurations of electromagnet windings for the self-excited motors are possible such as : series, shunt or compound.

The class of fractional horsepower DC motors which utilize permanent magnets differs from wound-field types in that no external power is required in the stator structure.

## 2.1 Wound-Field Motors

Straight-series motors provide very large torque at start-up due to their use of coils in series with the armature to produce the stator magnetic flux. Because the field windings carry the full armature current, it consists of a few turns of heavy gage wire. As motor speed increases, current reduces and so does the stator magnetic flux. This in turn causes another increase in the motor speed.

Straight series motor is usually employed where large starting torques are required. A typical straight-series motor is shown in figure 2.3.

Split-series motors are quite similar to straight-series motors, except that they have two field coils oppositely connected.

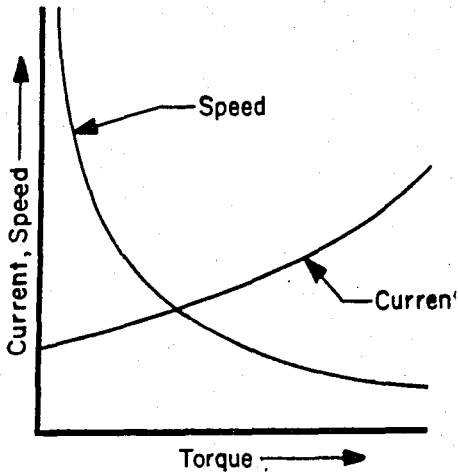
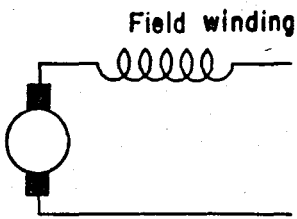

Fig. 2.3 Straight-Series Motor

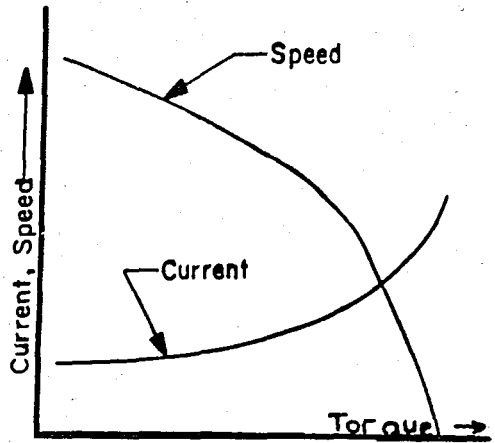
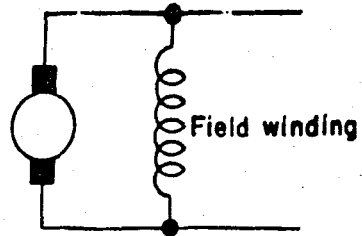

Fig. 2.5 Typical Shunt Motor

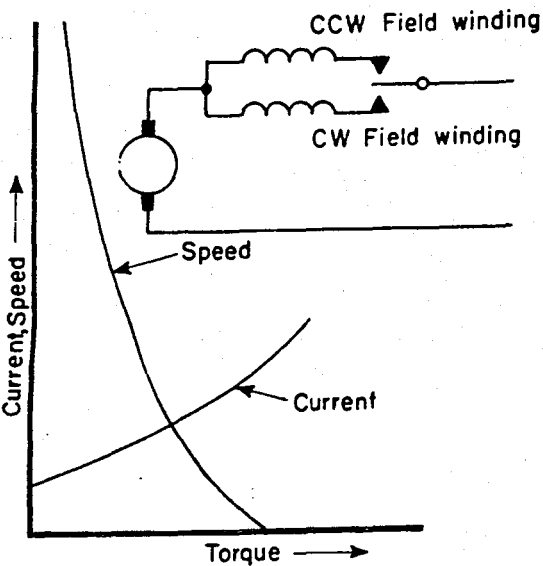

Fig. 2.4 Split-Series Motor

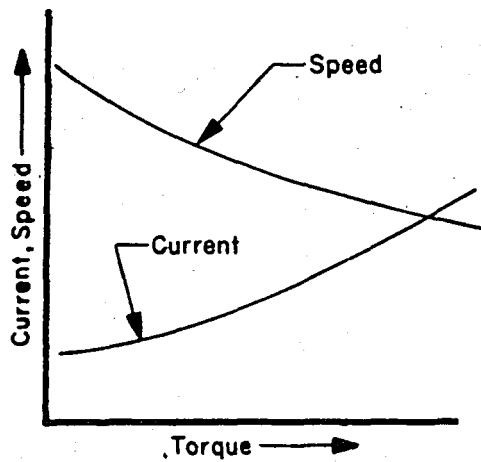
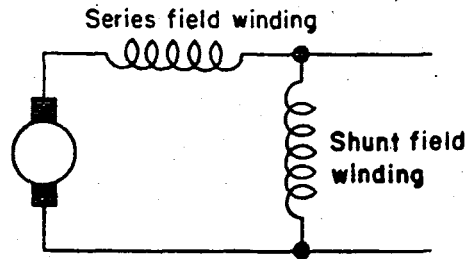

Fig. 2.6 Typical Compound Motor

This feature accommodates applications where rapid polarity changes of direction. A representative application of this type is their use in aircraft actuators. A typical split-series motor is shown in figure 2.4.

Shunt motors have armature and field coils connected in parallel. Line current in the armature is a function of the load configuration. The shunt motor has in the past been popular for both fixed speed and variable speed applications. The torque-speed characteristics are nonlinear at higher current level as shown in figure 2.5.

Compound motors have both series and shunt field windings. When the series field winding aids shunt windings, the motor is termed a " cumulative compound " motor, and when the series winding opposes the shunt winding, the motor is termed " differential compound " motor. In general, small compound motors have a strong shunt field and a weak series field to help start the motor.

The compound motor exhibits high starting torque and relatively flat speed-torque characteristics at rated load. In reversing applications, the polarity of both fields or of the armature must be switched. A typical is shown in figure 2.6.

## 2.2 Permanent Magnet ( PM ) Motors

Since the stator magnetic field is generated by permanent magnets, no power is used in the field structure, The stator magnetic flux remains essentially constant at all levels of armature current and therefore, the speed-torque curve of the PM is linear over an extended range ( See figure 2.7 ). With modern ceramic magnets, the stalled torque will tend to be higher and the speed-torque curve will tend to be more linear than for a comparable wound-field motor.

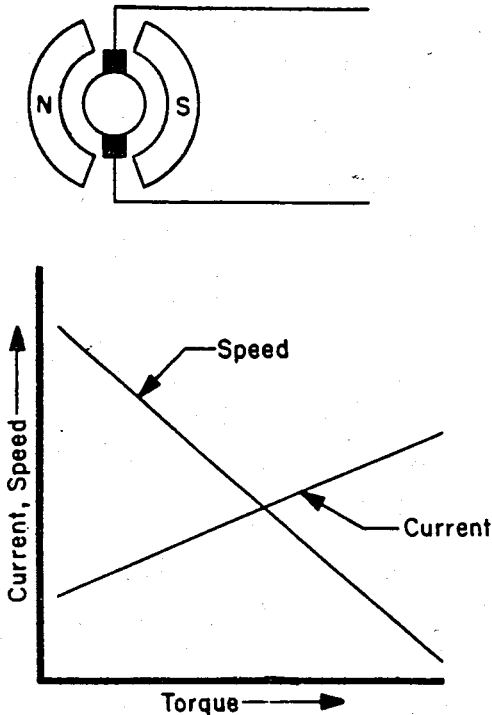

Figure 2.7 Typical Permanent Magnet Motor

A comparison of a permanent magnet motor and a shunt motor is shown in figure 2.8. The wound field motor has the nonlinear characteristics at higher torque levels, but, permanent magnet has a linear torque-speed characteristics.

The permanent magnet motor offers several advantages in addition to those discussed above. Perhaps, the most obvious advantage is that electrical power need not be supplied to generate the stator magnetic flux. Since the conversion of electrical power to mechanical power takes place in the armature. Winding results mostly in an  $I^2R$  loss (heat loss) in the winding itself. The permanent magnet motor, thus, simplifies power supply requirements while at the same time it requires less cooling.

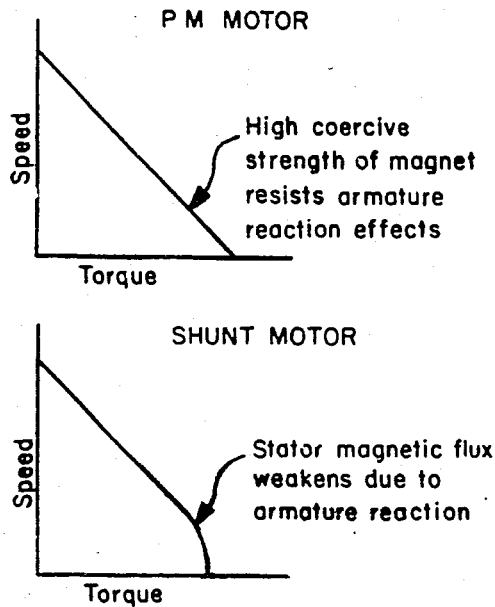

Figure 2.8 Speed-Torque curves are more linear for the PM motors compared to a shunt motor.

Another benefit of the PM motor is a reduced frame size for a given output power. Because of the high coercive strength of permanent magnets, their radial dimension is typically one-fourth that of the wound field motor for a given air gap (Ref.5)

The significant advantages of PM motors over wound field ones are summarized as follows ;

1. Linear torque-speed characteristics,
2. High stall ( accelerating ) torque,
3. No need for electric power to generate the magnetic flux,
4. A smaller frame and lighter motor for a given output power.

Because of the significant advantages of PM motors, they should be used in electric vehicles. However, we had to use separately excited DC motor because a PM was not available.

### 2.3 Control methods of a separately excited DC motor

The equivalent circuit of a separately excited DC motor is shown in figure 2.9 in which  $R_a$  is the total armature circuit resistance and  $L_a$  is the total armature circuit inductance.

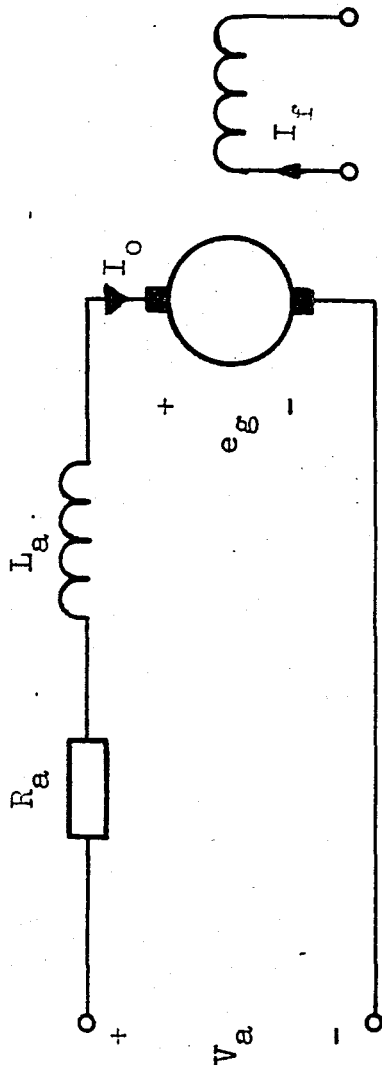

Figure 2.9 Equivalent circuit of a separately excited DC motor

The back emf is generated by the rotation of armature in the stator flux field. It is proportional to the speed of armature and the field flux and can be represented by

$$E_g = k_a \cdot \phi_f \cdot n \quad ( 2.1 )$$

The basic steady state armature circuit voltage equation is

$$V_a = E_g + I_a R_a \quad ( 2.2 )$$

The torque developed by the motor is directly proportional to the armature current  $I_a$  and the field flux, that is

$$T = k_t \cdot \phi_f \cdot I_a \quad ( 2.3 )$$

The simultaneous solution of the three equations yields for the basic speed relation in DC motors, that is

$$n = \frac{V_a - T(R_a / k_t \cdot \phi_f)}{k_a \cdot \phi_f} \quad ( 2.4 )$$

Where  $V_a$  = supply voltage,  
 $I_a$  = armature current,  
 $k_a$  = armature voltage constant,  
 $\phi_f$  = field flux,  
 $k_t$  = motor torque constant,  
 $n$  = armature speed,  
 $T$  = produced torque,  
 $R_a$  = armature resistance.

The first term in the above equation represents the theoretical no load speed. The second term which is usually very small, represents the speed drop produced by the armature current and hence the developed torque.

The equation (2.4) shows that the speed of a DC motor can be controlled by three methods. These are :

1. By the armature voltage  $V_a$  which is nearly proportional to speed,

2. By the magnetic flux  $\phi_f$  which is inversely proportional to speed,

3. By the armature circuit resistance  $R_a$  which is proportional to the speed drop.

Armature voltage control is the most desirable and practical type of control. This type of control is the basis for static DC drive circuits. In this method the field flux is held constant at its rated value and hence the variation of speed from zero to the base speed. The motor is said to be operating as a constant torque drive.

Field control is accomplished by reducing the shunt field current while keeping the armature voltage at its maximum value. It is used to extend the speed above the rated value. The speed can not be changed quickly owing to the high inductance of the field winding. In this method the developed torque reduces as the speed increases.

Armature circuit resistance control is not practical except for very small motors because of power dissipations. For these reasons, we decided to use the armature voltage control method.

## CHAPTER 3

### DC CHOPPER DRIVES

For the control of the voltage applied to the armature of a DC machine, chopper circuits are frequently used.

The DC chopper converts directly from DC to DC and is a relatively new technology. The chopper can be used in battery operated vehicles where saving is a prime consideration. Choppers used in subway cars reduce tunnel heating. Choppers can provide regenerative braking of the motor and return the energy back to the supply. This results in energy saving for transportation system with frequent stops. Chopper therefore, find wide applications in traction systems all over the world. Choppers will probably be used in future electric automobiles for speed control and braking. A few of good features of the chopper drives are ; smooth control, high efficiency and fast response and regeneration (Ref. 7)

#### 3.1 Principles of Chopper Operation

##### 3.1.a First quadrant chopper

A chopper is thyristor on/off switch that connects load to and disconnect it from the supply and produce a chopped voltage from a constant supply voltage. This is illustrated in figure 3.1 . The chopper is represented by an SCR inside a dotted square. During the period  $t_{on}$ , when the chopper is on, the supply terminals are connected to the load terminals. During the interval  $t_{off}$ , when the chopper is off, load current flows through the free-wheeling diode  $D_{FW}(D1)$ , and the load terminals are shorted. A chopped DC voltage is thus produced at the load terminals. The average load voltage  $E_o$  is given by

$$E_o = E \frac{t_{on}}{t_{on} + t_{off}} \quad (3.1)$$

$$= E \frac{t_{on}}{T} \quad (3.2)$$

$$= \alpha E \quad (3.3)$$

where  $t_{on}$  = on time,  
 $t_{off}$  = off time,  
 $T = t_{on} + t_{off}$  = chopping period,  
 $\alpha = t_{on}/T$  = duty cycle.

Therefore, both average load voltage  $E_o$  and current  $I_o$  are positive and thus, power flows from source to load. This configuration is used for motoring operation of a DC motor load. The load voltage is controlled by the duty cycle of the chopper. It can be varied in one of the following ways ;

1. Constant frequency system :  $f=1/T$ . The chopping frequency (and hence the chopping period  $T$ ) is kept constant and the on time  $t_{on}$  is varied. This may be called pulse width modulation.

2. Variable frequency system : The chopping  $T$  is varied and either a) on time is kept constant or b) off time is kept constant. This may be called frequency modulation.

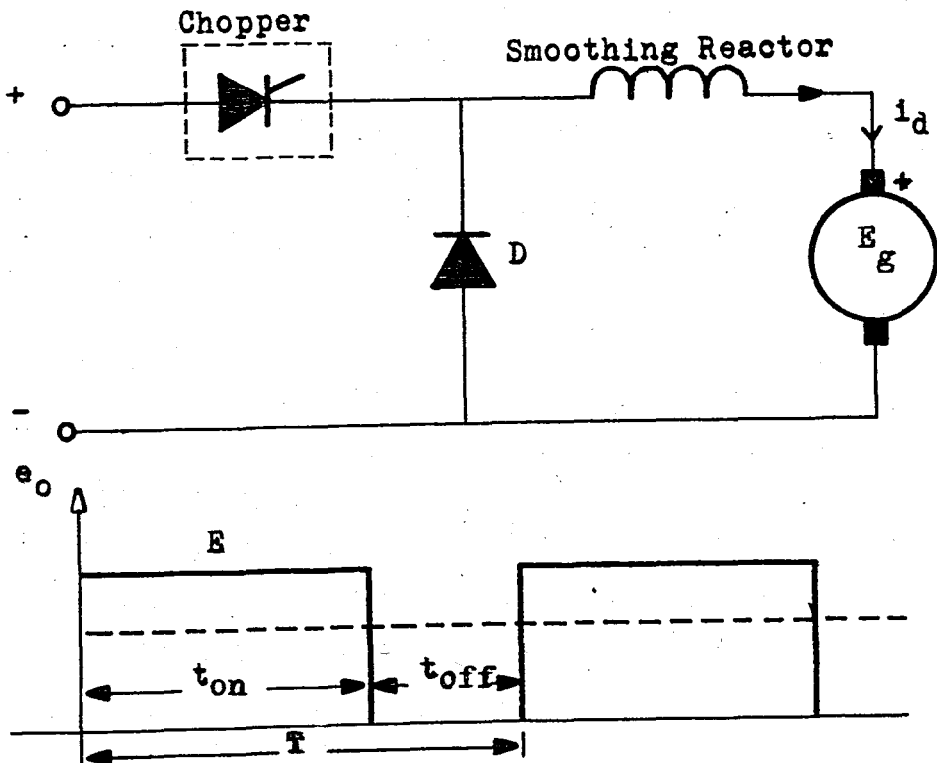

Figure 3.1 Basic chopper circuit configuration and operation

### 3.1.b Second quadrant or regenerative chopper

The chopper configuration shown in figure 3.1 produces output voltages less than the input voltage ( i.e.  $E_o < E$ ). However, a change in the chopper configuration as shown in figure 3.2 provides higher load voltages.

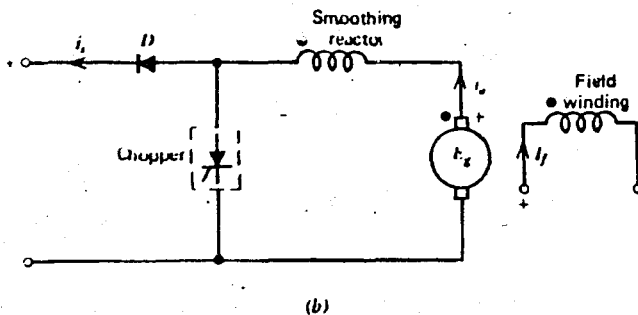

Figure 3.2 Step-up chopper configuration

When the chopper is on, the inductor is connected to the motor, and energy from the motor is stored in it. When the chopper is off, the inductor current is forced to flow through the diode and supply. The induced voltage  $e_L$  across the inductor is negative. The induced voltage adds to the motor voltage to force the inductor current into the supply  $E$ . If the ripple current in the source is neglected, then during the time the chopper is on the energy input to the inductor from the motor is

$$W_i = EIt_{on} \quad (3.4)$$

During the time the chopper is off, energy released by the inductor to the supply is

$$W_o = (E_o - E)It_{off} \quad (3.5)$$

For a lossless system, in the steady state, these two energies will be same

$$EIt_{on} = (E_o - E)It_{off} \quad (3.6)$$

from which

$$E_o = E \frac{t_{on} + t_{off}}{t_{off}} \quad (3.7)$$

$$= E \frac{T}{T - t_{on}} \quad (3.8)$$

$$= \frac{E}{1 - \alpha} \quad (3.9)$$

Thus, for a variation of  $\alpha$  in the range  $0 < \alpha < 1$ , the voltage  $E_o$  will vary in the range  $E < E_o < \infty$ . This principle of operation is utilized in the regenerative braking of a DC motor.

### 3.2 Two quadrant type A chopper

The above two circuits shown in figures 3.1 and 3.2 are combined in the two quadrant chopper, type A.

In figure 3.3.a,  $e_o = 0$  if chopper CH2 or diode D1 conduct and  $E = e_o$  if chopper CH1 or diode D2 conduct.  $e_o$  is therefore positive. However,  $i_o$  can reverse direction. It is positive if CH1 is on or D1 conducts and negative if CH2 is on or D2 conducts. Since  $e_o$  is positive and  $i_o$  is reversible, power flow is reversible. This chopper configuration may be used for both motoring and regenerative braking of a DC motor. Because of these characteristics, in this thesis, it is intended to use chopper A type as a drive circuitry.

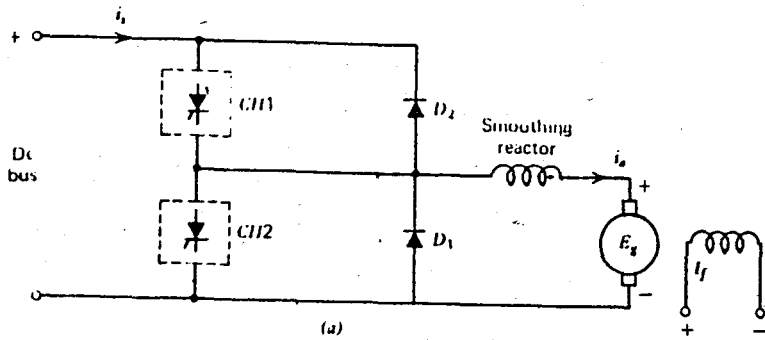

(a)

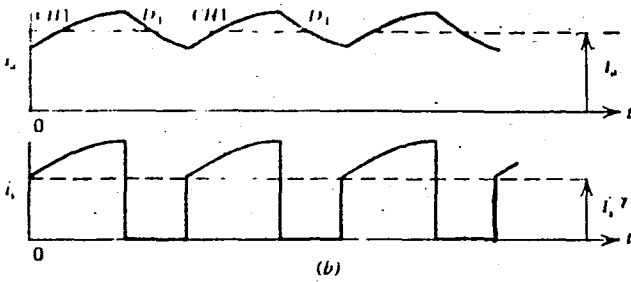

(b)

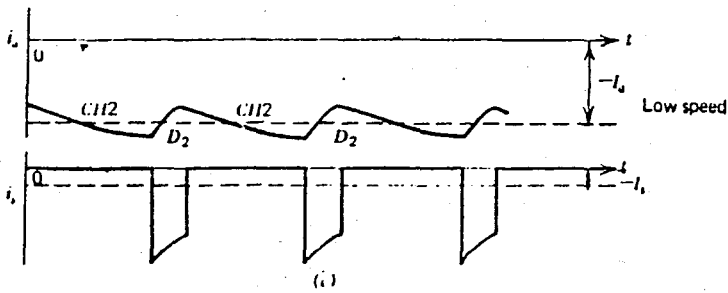

(c)

Figure 3.3 A chopper drive using two quadrant chopper for motoring and regenerative braking.

a) circuit schematic, b) motoring, c) regenerative braking

We have been considering a chopper as an ideal on-off switch represented by an SCR inside a dotted square. A chopper is, in fact, a main power SCR switch together with the commutation circuitry to turn it off. There are various ways in which an SCR can be turned off.

Main power switch is the thyristor. Once the thyristor is operating in the on state, carrying forward current, it can only be turned off by reducing the current flowing in it to zero for sufficient time to allow removal of the charge carriers. When operating from AC supplies, the regular reversal of voltages and currents allows turn off to be carried out naturally. When power is supplied to the circuit as direct current, there are no natural zero current or reversal periods and some other means of turn off is needed.

If the commutation circuitry is included with the main thyristor, it is possible to force thyristor current to zero. This process will be referred to as forced commutation and it allows the thyristor to be operated as a real switch capable of being opened and closed at will (Ref. 6)

## CHAPTER 4

### MICROPROCESSOR BASED SPEED CONTROL SYSTEM FOR a SEPARATELY EXCITED DC DRIVE.

In recent years significant progress has been made in digital control systems. These systems have gained popularity and importance in all industrial applications due in part to the advances made in digital computers and more recently in microprocessors as well as the advantages found in working with digital systems.

In this chapter the design of a microprocessor based speed control of a DC motor fed by two-quadrant DC choppers is described. The system is centered around a 6802 based microcomputer with the analog to digital converter ( successive approximation type ) and the pulse amplifier. The software used manipulates the PID control algorithm and keeps the desired speed.

#### 4.1 Description of the system

A separately excited DC motor with ratings of 3/4 hp, 125 V, 6 A and 1450 rpm is being controlled by means of the A type chopper, the output voltage of which is directly controlled by the MEK6802D5 microcomputer. The actual speed of the motor and the reference are sensed by means of an 8-bit analog to digital converter.

The MEK6802D5 microcomputer evaluation board used in the thesis does three main functions ; Firstly, it reads the reference speed for the motor which are stored in the microcomputer memory. Secondly, does all the necessary calculations and the desired control algorithm. It outputs the desired command signals to turn on/off the appropriate chopper, lastly.

In the design stage a minimization of the external hardware is aimed for and the software is developed accordingly. The software makes it possible to operate the closed loop system at different  $K_p$ ,  $K_I$  and  $K_D$ , just by storing the desired values in the appropriate memory locations.

The block diagram of the complete system is shown in figure 4.1 and in more detail in figure 4.2. The circuit details and the functions of each block diagram are explained.

#### 4.1.a Basics of microprocessors and microcomputers

A conventional analog control method has several disadvantages such as the nonlinearity in the analog speed transducer, difficulty in accurately transmitting the analog signal, errors due to temperature, component aging, drift and offset of the analog components, extraneous disturbances and so on.

A digital control, on the other hand, is free from these disadvantages. The control circuitry is conventionally made of hardwired logic circuits. This is satisfactory if the control requirement is simple. However, if the control system becomes very complex and if flexibility of operation is required, hardwired logic circuits may not meet the requirement. For example, the battery powered electric vehicle drive control designed here requires sophisticated and complex controls such as optimum control of speed, as well as regeneration and braking for energy conservation. It may also be necessary having highly accurate algorithm, good speed resolution and fast response. These tasks can be performed better by using a microcomputer based system rather than hardwired logic circuitry.

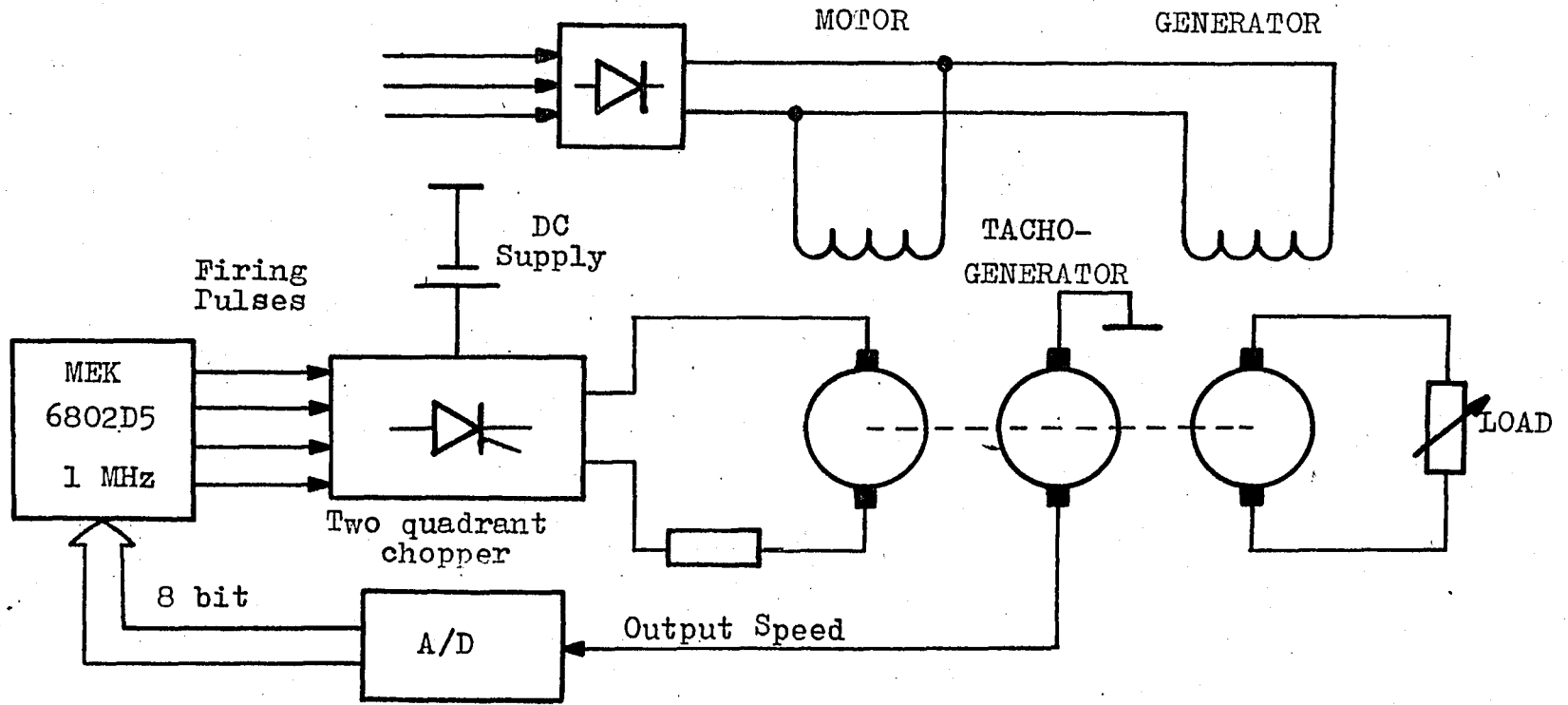
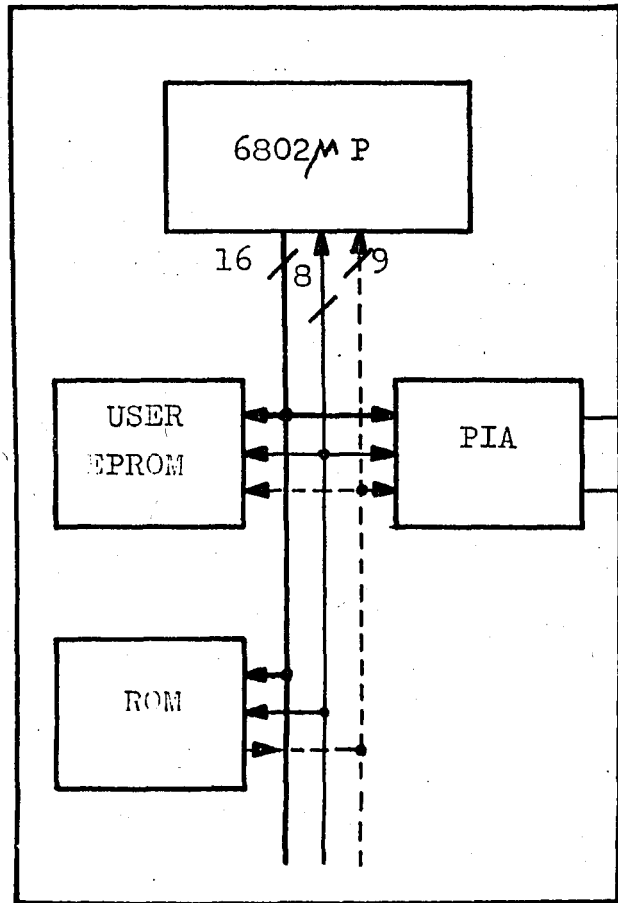
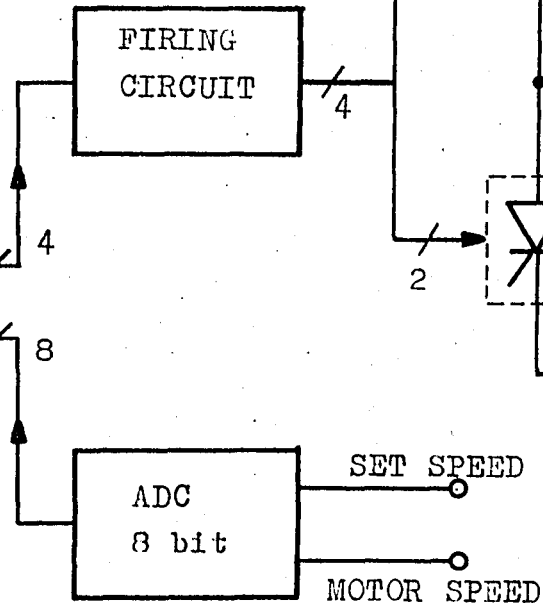

Figure 4.1 The Block Diagram of the System



MEK6802D5



TWO QUADRANT TYPE  
A CHOPPER

Figure 4.2

#### 4.1.b The MEK6802D5 microcomputer evaluation board

The MEK6802D5 microcomputer evaluation board allows the user to become familiar with the MC6800 family of microprocessors. The three basic components of the D5 are 1) U5, the MC6802 microprocessor, 2) U12, the MC68A1316E ROM, and 3) U23, the MC6821 PIA (Ref. 8).

The MC6802 is the heart of the D5 system. The 6802 is an 8-bit microprocessor that can execute 72 different (exact instruction set of the MC6800). Included are binary and decimal arithmetic, logical, shift, rotate, load, store, conditional or unconditional branch, interrupt and stack manipulation instructions.

The MC6802 has a set of registers and accumulators plus an internal clock oscillator and driver. The 128x8 bit RAM has been added to the basic MPU. The first 32 bytes may be operated in a low power mode via  $V_{cc}$  standby. These 32 bytes can be retained during power up and power down conditions via the RE signal.

The MPU has three 16-bit registers and three 8-bit registers available for use by the programmer ( figure 4.6 ).

Program counter : is a two byte (16 bits) register that points to the current program address.

Stack pointer : is a two byte register that contains the address of the next available location in an external push down/ pop up stack.

Index register : is a two byte register that is used to store data or 16-bit memory address for the indexed mode of memory addressing.

Accumulators : The MPU contains two 8-bit accumulators that are used to hold operands and results from arithmetic logic unit (ALU).

Condition code register : indicates the results of an arithmetic logic unit operation ; Negative (N), Zero (Z), Overflow (V), Carry from bit 7 (C) and Half carry from bit 3 (H). These bits of the condition code register are used as testable conditions for the conditional branch instructions. Bit 4 is the interrupt mask bit (I). The used bits of the condition code register (b6 and b7) are ones.

For a more detailed explanation and description of the MC6802 microprocessor, refer to the reference 12.

The MEK6802D5 utilizes a 3.58 MHz crystal to control this circuitry (this results in a system operating speed of 895 kHz). Power on reset is accomplished by components R and C.

Basic to the operation of the D5 system is the data bus (eight lines labeled D0 through D7) and the address bus (16 lines labeled A0 through A15). These buses interconnect to the various sections. The address bus is further decoded by the address decode logic into select lines.

In the ROM (read only memory) instructions are stored permanently. The memory is a unit where instructions and data are stored. The memory contains a large number of locations or cells. The size of the memory is equal to the number of locations in the memory. Unlike some types of memories, this ROM retains data whether the power is on or not. The ROM section consists of the D5BUG Monitor and the User EPROM.

The RAM section consists of a 128 byte static random access memory. This memory will retain its stored data as long as power is applied to it and can be written into and read out of as desired. The D5 uses this RAM as a scratch pad, which is a temporary storage for program material being processed. An example of this could be a program that uses a set of data a large number of times during the running of the whole program. This device would allow that data to be referred to as needed, rather than being repeated over again in the main program.

Another D5 board feature is the User RAM. This provides the user with an additional (1k) bytes of memory. These memories are volatile, and power must be supplied to them to retain their stored data.

The system PIA has two 8-line I/O port and four control I/O lines for a total of 20 interface lines. The four control lines provide for a variety of handshake operations. The two I/O ports are controlled by software to configure these 16 lines as inputs or outputs in any combination.

The user PIA allows the processor to talk to the outside world. The 16 I/O lines and 4 control lines are connected to a 24-pin socket.

The system PIA uses its A side to drive the anode segments of the LED displays and the B side to drive the LED cathodes. The processor put data into the register of the PIA to display on one of the LED's, then places data in the PIA registers to drive the next display element, etc. at a rapid enough rate that the display appears steady.

The keypad is connected to the cathode drivers of the LED's so that when a key is depressed, an interrupt signal is generated. This interrupt signal causes the CPU to call up a routine in D5BUG, which then enables it to search for the key that was closed. The PIA is used to enter a new data or display data in the system.

The D5 can be supplied to interface to the widely used RS232 bus. An Asynchronous Communications Interface Adapter (ACIA) converts the parallel data on the data bus to a serial form suitable for transmission over a communications system.

Addressing : The MEK6802D5 accesses 64K of memory space by use of 16 address lines A0 through A15. The addresses E000 to FFFF access parts on the MEK6802D5 and external data buffers are not enabled for such accesses. The area from 0000 to 007F is RAM within the MC6802 and when the optional edge connector bus buffers are installed, all accesses to addresses 0000 to DFFF are considered to be off-board. The system memory map is shown in figure 4.4, the system Timing Diagram in fig. 4.5.

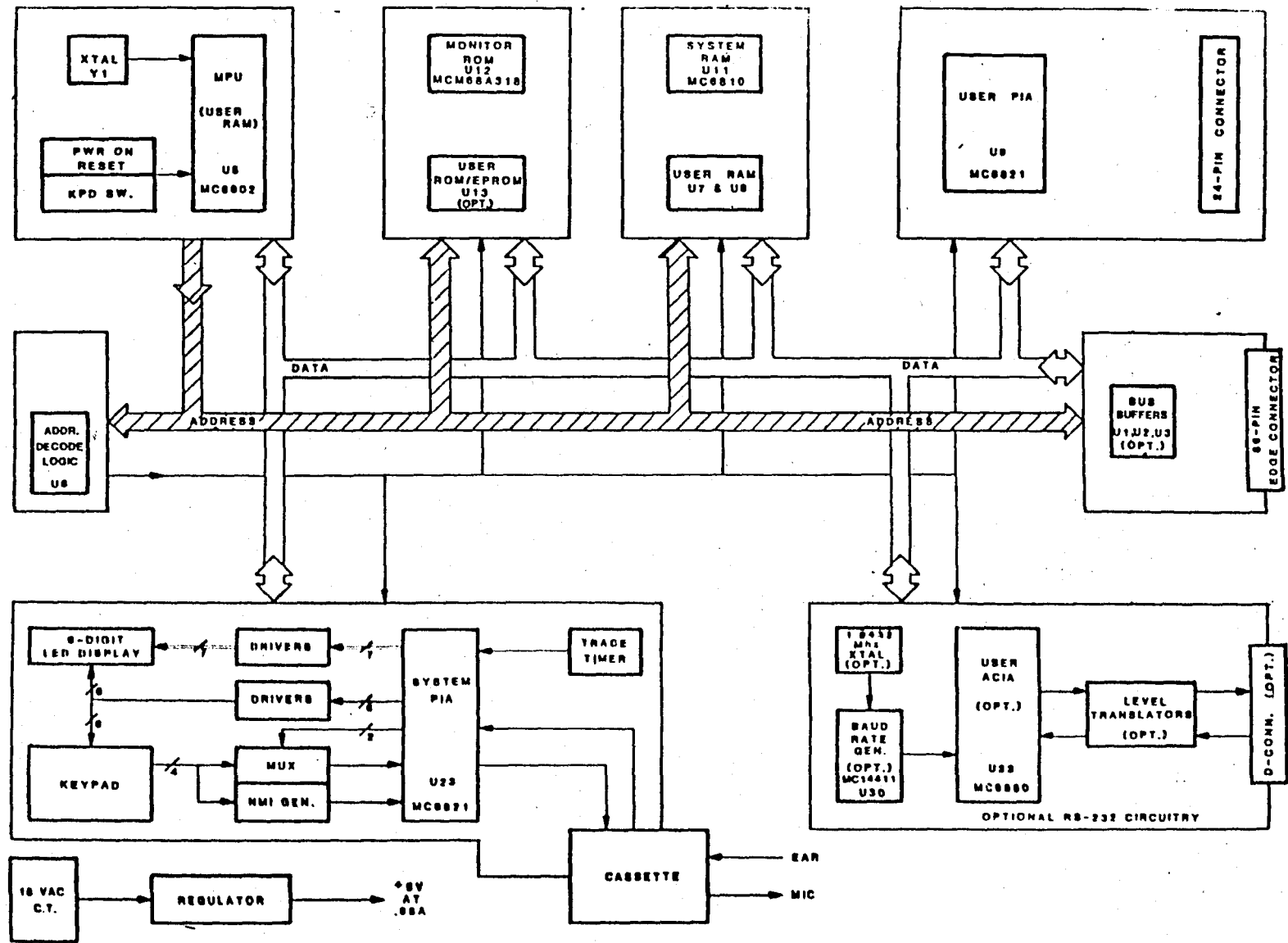

FIGURE 4.3. BLOCK DIAGRAM

F000	F000	Operating System Mirror (or optional user ROM)
F7FF	F7FF	
F800	F800	Operating System (D5BUG)
F7FF	F7FF	
F000	F000	Optional User ROM
EFFF	EFFF	
E800	E800	Reserved
E700-E701	E700-E701	System ACIA*
		Reserved
E487	E487	System PIA
E484	E484	User PIA
E483	E483	
E480	E480	System RAM
E47F	E47F	
E400	E400	User RAM (1K)
E3FF	E3FF	
E000	E000	External to MEK6802D5
DFFF	DFFF	
0080	0080	User RAM inside MC6802 (must be disabled if optional Bus buffers are installed)
007F	007F	
0000	0000	

\*ACIA is not supported by D5BUG software.

Figure 4.4

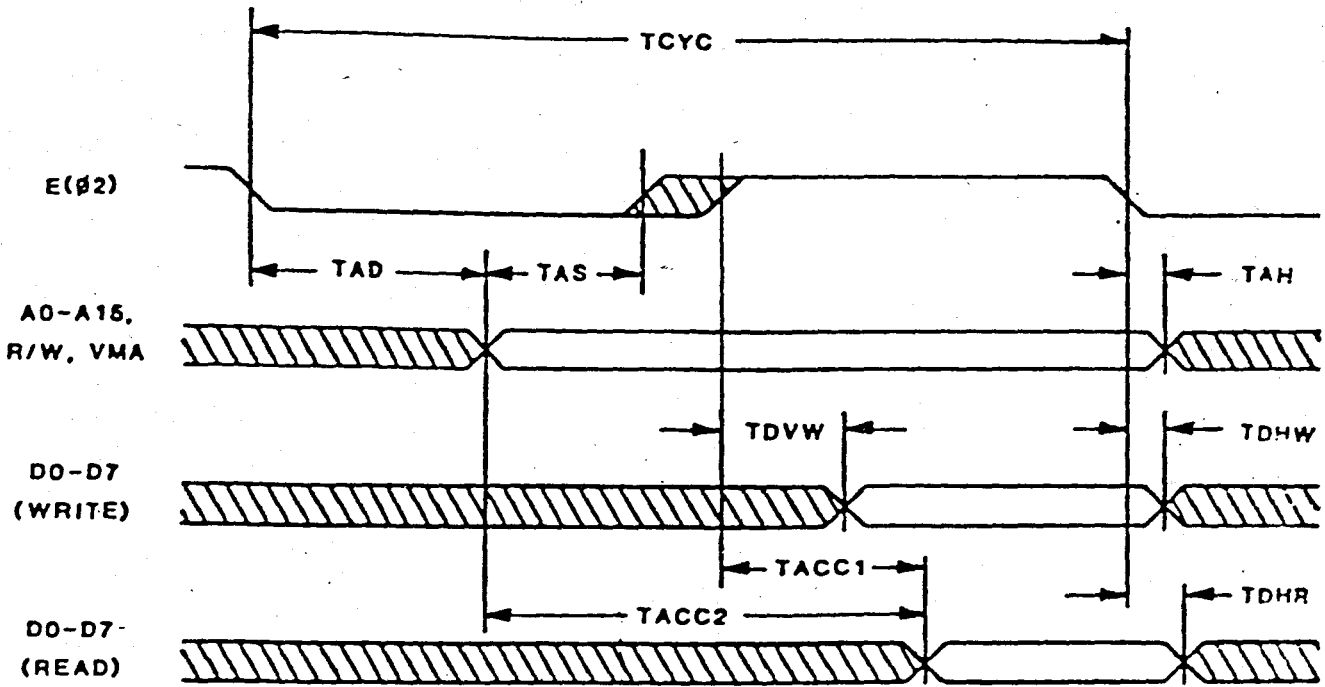

Figure 4.5 System Timing Diagram

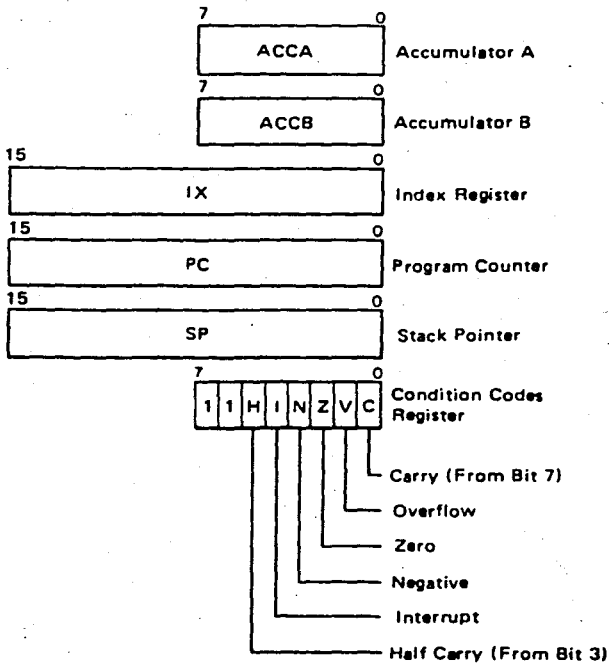

Figure 4.6 Programming Model of the Microprocessing Unit

#### 4.1.c Analog to digital converter circuit

Speed information can be fed into the microcomputer using either a DC tachometer and an A/D (analog to digital) converter or by a digital tachometer and a digital counter. The motor speed and set speed considered here are fed into the computer through a fast A/D converter (successive approximation type). The set speed is set by a potentiometer and the motor speed by a DC tachometer. They are buffered by an operational amplifier circuit which are second order low-pass filters with unity gain. Its cutoff frequency is approximately 100 Hz. The outputs of amplifier circuits are connected to analog multiplexer/demultiplexer (MC 14052B). The MC14052B, analog multiplexer is digitally controlled analog switches. It implements an 4PDT or 2PDT. Its feature low on impedance and very low off leakage current. Control of analog signals up to the complete supply voltage range can be achieved. PB6 and PB7 (PIA's Port B) used as outputs are connected to the control (A and B) inputs of MC14052. The OP-AMP 1's output is connected to the  $Y_0$  pin of MC14052 and the OP-AMP 2's output to the  $Y_1$  pin of MC14052. The  $Y_0$  and  $Y_1$  act as inputs and Y as an output. The major function of the MC14052 is to serve as a switch to read and sample the set and motor speed sequentially. The selecting of the inputs is under the control of PB6 and PB7. Each one of the inputs require a different combination of control inputs A and B. For example, if PB6 and PB7 are both low, set speed is fed into successive approximation type analog to digital converter and if PB6 is low and PB7 is high, motor speed is passed to the A/D converter. The inhibit input of the MC14052 is taken from MC14559's inverse of EOC output. While the system is in the conversion cycle, the inhibit input of the MC14052 will be high. Therefore, all of inputs will be disconnected.

After the conversion cycle is complete, the inhibit input will be low and one of the inputs will be selected for conversion. Before going to A/D, sampling and holding processes are completed. ( See appendix D )

Holding capacitor is directly connected to the successive approximation type of analog to digital converter. The basic block diagram of the system shown in figure 4.7 consists of a voltage comparator (IC7), a voltage output D/A (IC8), successive approximation register (SAR) (IC9) and a clock circuit (IC10).

As the theory of operation of the S/A type of A/D is quite well documented and available in many texts on A/D systems, it will not be dealt with rigorously here, but, the basic system operation will be illustrated in order to define some terms for the A/D circuit. In operation, the system enables the bits of the D/A one at a time, starting with the most significant bit (MSB). As each bit is enabled, the comparator gives an output signifying that the input signal is greater or less in amplitude than the output of the D/A. If the D/A output is greater than the input signal, the bit is reset and turned off. The system does this with the MSB first, then the next most significant bit, then the next, etc. After all the bits of the D/A have been tried, the conversion cycle is complete. At this time, another conversion cycle is started.

At the start of the conversion cycle, the MSB of the D/A is enabled, presenting a voltage to the comparator of half-scale or  $V_{ref}/2$ . The comparator makes a decision as to which of its two inputs are greater and gives the appropriate output, a high if  $V_{in}$  is the greater and a low if the D/A output voltage is the largest. The S/A storage register then turns off the MSB if the comparator is low. This process is repeated sequentially for each bit of the system. ( Ref. 9 )

The serial output of the system is taken from the output of the comparator. While the system is in the conversion cycle, the comparator output will be either low or high, corresponding to the digital state of the respective bit. In this way, the successive approximation A/D gives a serial output during conversion cycles.

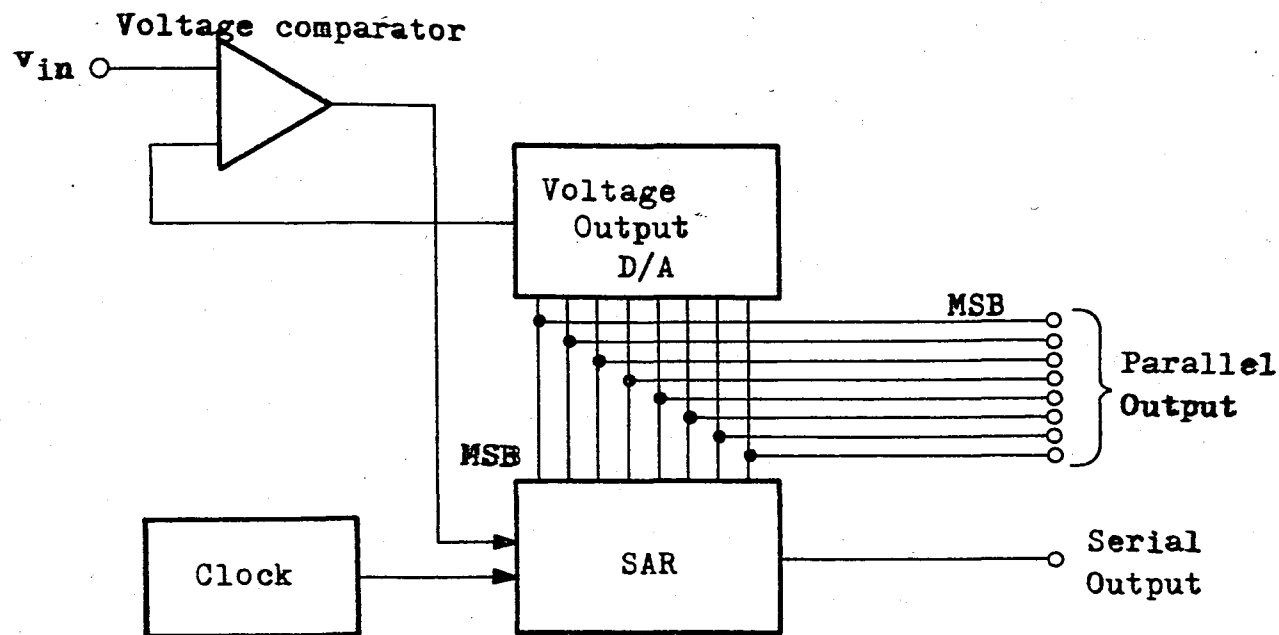

Figure 4.7 Basic Block Diagram of Successive Approximation A/D System

Appendix C shows a schematic diagram of an S/A type A/D and a CMOS SAR. The system operates on +5 and -6 volt supplies, and will operate at 5.5 sec/bit conversion rates.

In operation, the input voltage  $V_{in}$  across C10, drives an LF355 OP AMP (IC6), connected as a noninverting, unity gain buffer which is used to translate impedances so that the impedance of the driving source has no effect on the A/D's output.

The output of the D/A is a current sink proportional to the reference current  $I_{ref}$  and the digital word on the address lines of the D/A, inputs A1 through A8. The digital word input to the D/A will be represented by X

$$I_o = I_{ref} \cdot X \quad (4.1)$$

$$I_{ref} = V_{ref} / R_{ref} \quad (4.2)$$

where  $I_o$  is the output current sink of the D/A.

$$V_o = V_{in} - R_{12}I_o \quad (4.3)$$

The comparator, IC7, compares  $V_o$  to  $V$  offset which is  $-1/2$  LSB. If  $V_o$  is greater than  $V$  offset the output of the comparator is a one. Full scale voltage (11111111) of the system as set up was 1.06 volts. Any value of full scale could be chosen as long as one does not saturate the input buffer amplifier (input voltage must stay about 1 volt below the positive supply of the OP AMP to keep it out of saturation) and the equation (4.4) and (4.5) are followed.

$$\frac{V_{ref}}{R_{ref}} = \frac{V_{FS}}{R_{12}} \quad (4.4)$$

$$0.5 \text{ mA} \leq I_{ref} \leq 0.4 \text{ mA} \quad (4.5)$$

Calibration of the system is very easy. Simply put a voltage of full scale minus  $1/2$  LSB into the input and adjust the full scale calibrate ( $R_{ref}$ ) to make the transition from (11111110) to (11111111) occur at this point. Now put an input of  $+1/2$  LSB into the system and adjust pot to set the 00000000 to 00000001 transition to occur at this point.

The system will run at  $5.5 \mu\text{sec/bit}$  giving a total conversion of  $(n+1) \times 2$  sec. In this case,  $n$  is 8 so the system has a conversion time of  $9 \times 5.5$  or  $49.5 \mu\text{sec}$ . The primary limit of speed in the system is the propagation delay time of the comparator (LM311) and the SAR (MC14559). The propagation delay of the SAR is about 450 nsec at 5 volts. The propagation delay for LM311 is on the order of 200 nsec. Adding the propagation delays gives about 650 nsec. When the setting time of the D/A is added in about 250 nsec, total delay is 900 nsec. So, the clock which speeds up to 180 kHz is adequate.

The start conversion pulse for IC9 is given by the CA2 handshake output of PIA and End of Conversion is detected by using CA1 handshake input of PIA. The operation mode of these control lines is determined by the bits in the A control/status. Control lines, in turn, affect the contents of bits 6 and 7 of the control status registers as will be explained.

The configuration of the Control/Status Register is shown in table 4.A. If bit 2 of the Control Register (CRA2) is a 1, the Data Register is accessible, whereas if it is a 0, only the Direction Register can be accessed. Status bits 6 and 7 are set by the transitions of the CA1 and CA2 lines. The rest of the bits in the Control/Status Register are used to select the functions of the control lines. Bits 6 and 7 can not be changed from the microprocessor bus are reset indirectly by a READ data or WRITE data operation. (Ref. 10)

Control line CA2 and CB2 can be used either as input or output control lines, and are controlled by bits 3,4 and 5 of the Control/Status Register. If bit 5 of the Control/Status Register is a 0, the lines function as interrupt inputs otherwise, act as outputs. They can be directly programmed, if CRA5 and CRA4 are both 1's, the CA2 assumes the same level as CRA3. This allows the program control the length of time CA2 is low or high. For example, in our case, the accumulator is loaded with IMMEDIATE value (3C) byte and it is stored to the PIA Control Register. This causes CA2 to go high, thus starting the conversion. Then, the control word is 34 and bit CRA3 is now made low, which causes CA2 to return to low terminating the strobe pulse to the SAR. The next step to watch for the End of Conversion to set the interrupt flag status bit CRA7, whenever there is a negative transition ( $\bar{1}$ ) on the CA1. This is determined by testing the word loaded into A to see if it is positive (bit 7 is a zero). If it is positive, the program is branched back to input the word again and test it. This loop is repeated until the status goes negative.

Table 4. A

PIA Control word format

CRA	IRQA1	IRQA2	CA2 Control	DDRA ACCESS	CA1 Control
CRB	IRQB1	IRQB2	CB2 Control	DDRB ACCESS	CB1 Control

Once SET, CRA7 can only be cleared by reading DATA register A. After this, microprocessor will carry out various tasks. First of all, it does necessary calculations by using the PID algorithm and generates the new firing pulses and send them to SCR's through PIA's Bport to regulate the motor speed.

#### 4.1.d Pulse Amplifier

It has been assumed that thyristors (SCRs) in the choppers are fired at the desired instant for proper operation. The pulses coming from PIA's B port may not be strong enough to turn an SCR on. Besides, the gate and cathode terminals of the SCR are at higher potentials of the power circuit and the PIA's B port can not be directly connected to the choppers. An optical isolation or pulse-transformer isolation is commonly used in practice to provide physical isolation between the microcomputer and the choppers. Figure 4.8 shows a pulse amplifier circuit using a pulse transformer isolation. A Darlington transistor is used to amplify the pulse-current.

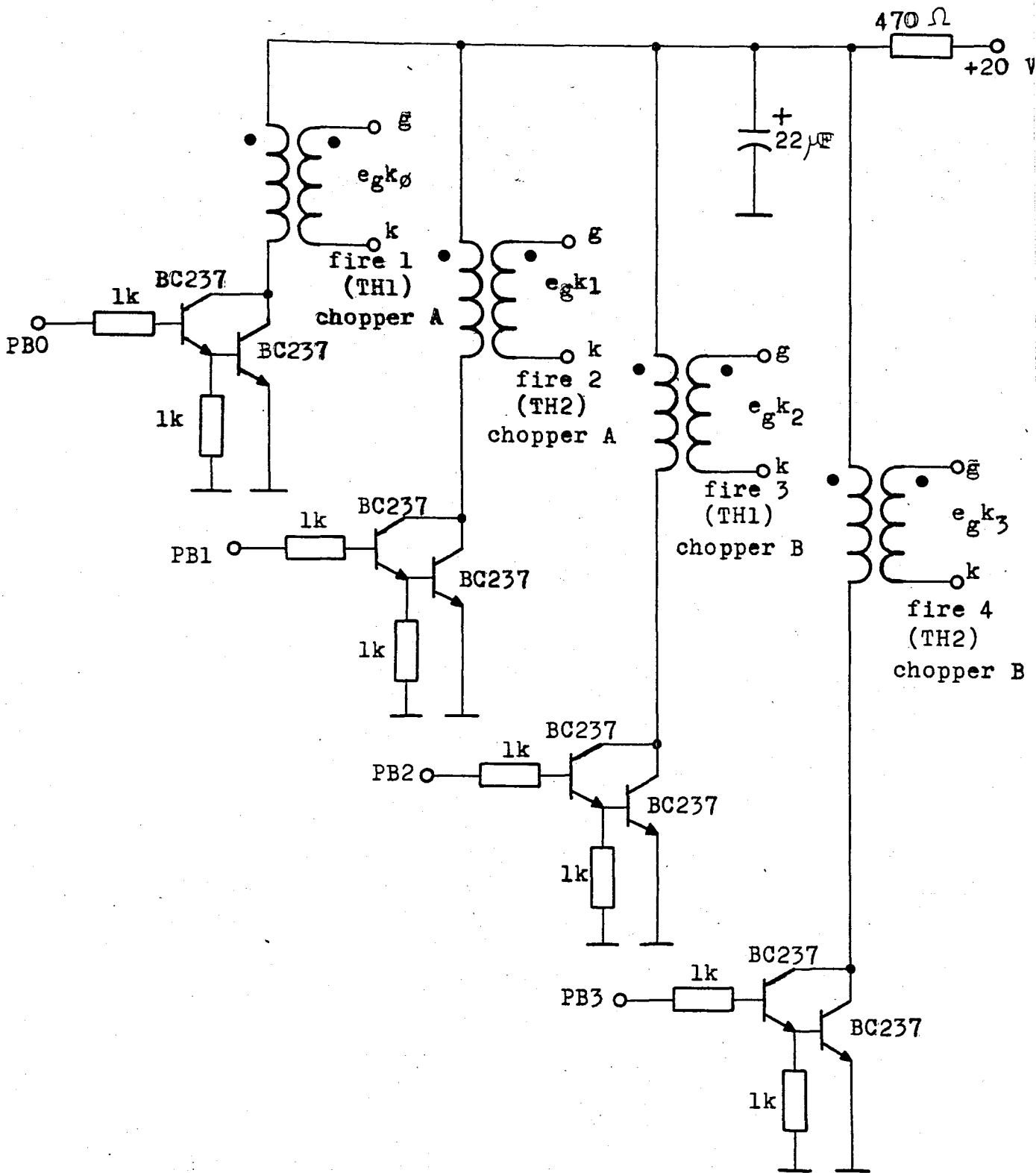

Figure 4.8 Pulse Amplifier Circuit

#### 4.1.e The Propulsion Control System

The propulsion control system consisting of a separately excited DC, a 125 V battery and a two-quadrant chopper is shown in figure 4.9. This configuration can be used during both motoring and regenerative braking depending on which of the two choppers A and B are in the conduction state.

Choppers shown in figure 4.10 are one of the earliest choppers and have been used widely. Main power switch is the thyristor  $TH_1$ . Its commutation circuitry consists of an auxiliary thyristor  $TH_2$ , diode D, inductor L and capacitor C which are implemented to turn  $TH_1$  off.

The use of two thyristors, one to control turn-on and one to turn the main the thyristor off, allows a much higher degree of control and flexibility.

To start the circuit, the capacitors are charged by triggering commutation thyristors ( $TH_2$ ) first. They will turn off after a few sec.

At cruising speeds where motor supplies the steady-state power requirement, control is achieved by varying the phase of the conduction intervals of the  $TH_1$  and  $TH_2$ . Thyristor 1 switches the supply into the armature terminals of motor, thereby an armature current ( $I_a$ ) is furnished in the positive sense.  $TH_1$  also charges up to the commutating capacitor C via D2 and L to a suitable positive value. The polarity change is in a direction so as to turn off  $TH_1$  when  $TH_2$  is triggered on. Subsequent to turn off the  $TH_1$  the freewheeling diode  $D_{FW}$  becomes forward biased and takes over the armature current until  $TH_1$  is turned again. The operation of chopper A is shown in figure 4.10 clearly.

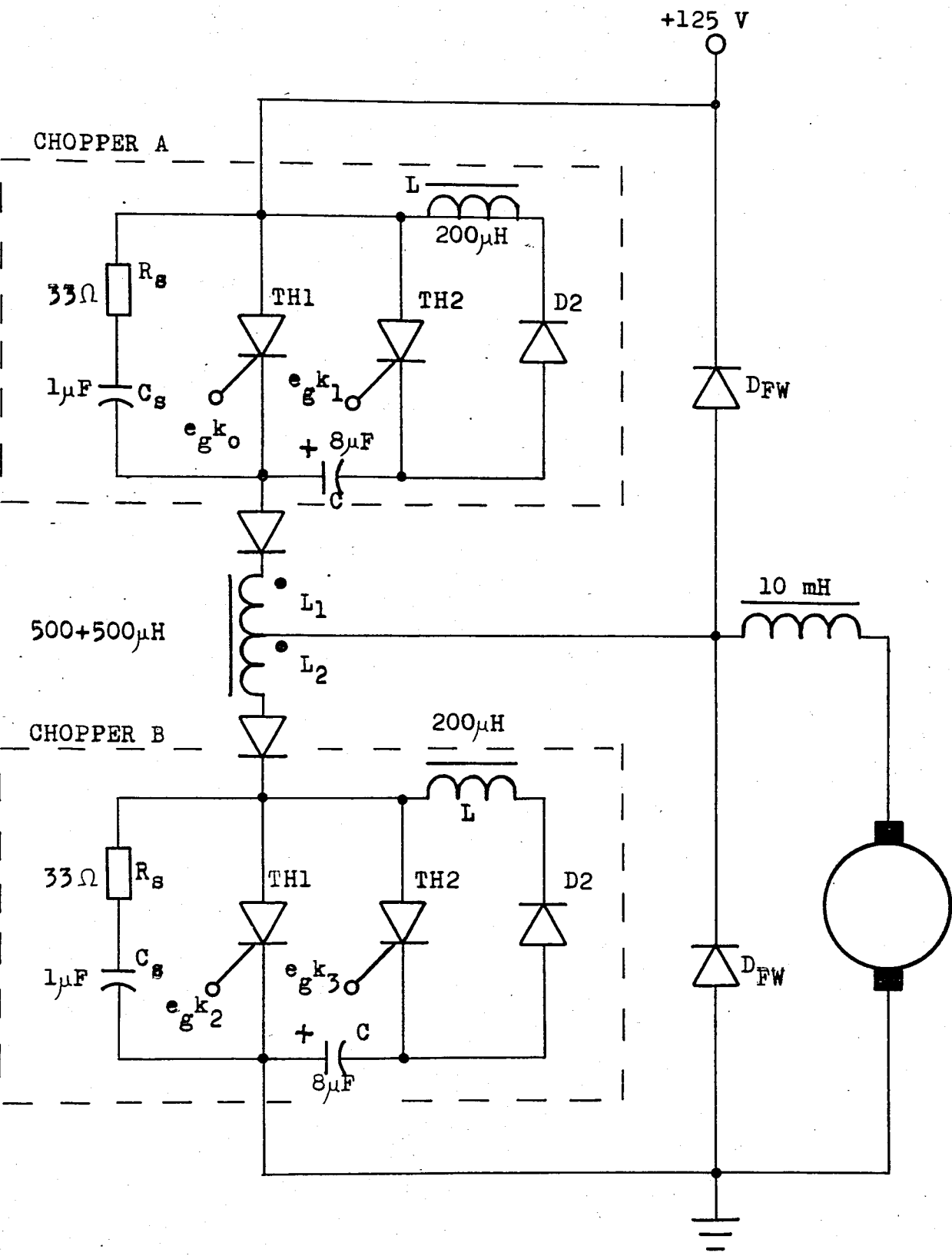

Figure 4.9 The Schematic Diagram of the Propulsion System

Chopper B is employed during regenerative braking only when the motor speed exceeds the reference. In regenerative braking mode when the chopper is on the motor terminals are shorted. The armature current builds up and energy is stored in the reactor connected in series with the armature. When the chopper B is off, armature current is forced into the supply. Energy stored in the reactor from the armature is thus released to the supply.

The voltage overshoots  $dv/dt$ , across the main thyristor is limited by the snubber circuit  $R_S-C_S$ . In practical applications the turn-off time provided to the SCR by the circuit, called the circuit turn-off time, must be greater than the device turn-off by a suitable safety margin ; the device, otherwise, will turn on at an undesired instant, a process known as commutation failure. To protect it against commutation failure,  $L_1$  and  $L_2$  shown in figure 4.8 are used.

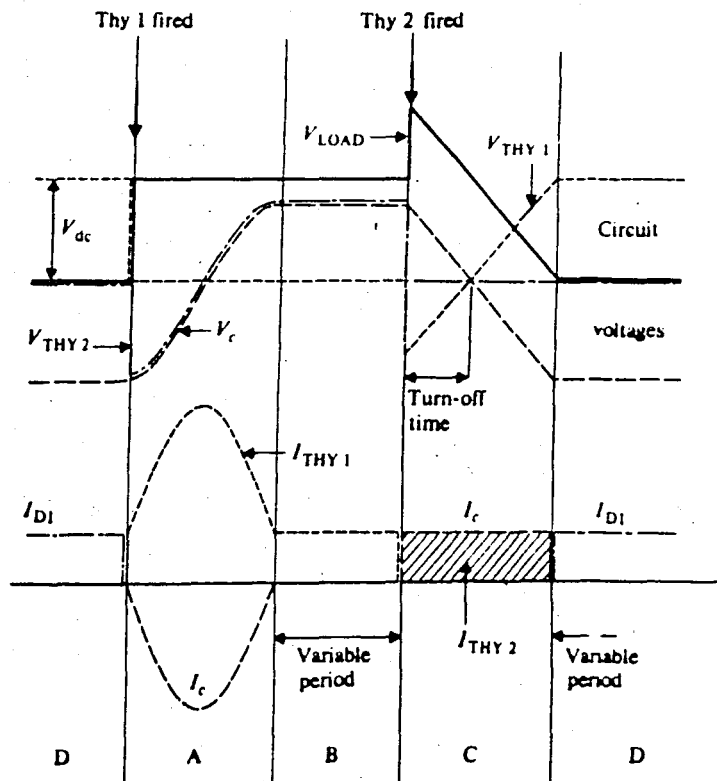

Figure 4.10 The Operation of Chopper A

## 4.2 System Software

### 4.2.a PID Control Algorithm

There are many control algorithms. The most popular are the on-off, proportional, derivative and integral control. In this thesis a PID digital control algorithm (proportional, integral, derivative) will be examined. The PID digital algorithm is often used where complete knowledge of the process or plant is lacking. Here, it is sufficient to control process within a certain range. For processes or plants that do not require full PID control, we can use one or more of the individual controls in the PID algorithm (Ref. 11).

The outputs of the PID algorithm in analog systems is

$$V_{PID}(t) = K_p e(t) + K_p T_d \frac{de(t)}{dt} + \frac{K_p}{T_I} \int_0^t e(t) dt \quad (4.6)$$

↑
↑  
 Derivative term      Integral term

where  $e(t)$  is the instantaneous value of the error. Transfer function in Laplace domain can be found as

$$\frac{V(s)}{E(s)} = K_p \left( 1 + \frac{1}{T_I s} + T_d s \right) \quad (4.7)$$

↑
↑  
 Integral term      Derivative term

Derivative term  $\left( K_p T_d \frac{de(t)}{dt} \right)$  can be written as

$$D_N = K_D (E_N - E_{N-1}) \quad (4.8)$$

in the discrete form, where  $E_N$  is the new error and  $E_{N-1}$  is the previous error.

The integral term can be written as

$$I(t) = \int_{t_0}^t e(\tau) d\tau + I(t_0) \quad (4.9)$$

where  $t_0$  is the initial time and  $I(t_0)$  is the initial value of  $I(t)$ .

To approximate the intergal in discrete form, the equation (4.9) will be as ;

$$I(N)=E(N)+ I(N-1) \quad (4.10)$$

where  $E_N$  is the new error and  $I(N-1)$  is the previous integral part.

The controller output will be as ;

$$V(N)=K_p E(N)+K_I I(N)+K_D(E_N-E_{N-1}) \quad (4.11)$$

It is seen that the evaluation of the control word is straight forward and only the previous values of error and intergal are needed.

#### 4.2.b Software

The program flowchart written to work with the hardware described in the previous section is shown in figure 4.11.

In order to maintain software flexibility, most of the tasks were written as subroutines.

First of all, appropriate values of  $K_p$ ,  $K_I$  and  $K_D$  are stored in the 0010, 0011, 0012 locations of MC6802, respectively.

At the beginning of the program, PIA is initialized, total error and momentary error should be cleared. Upon completing the initialization, commutation thyristors of choppers are fired and then the processor gets the digitized set and motor speed and stores them in the 0000 and 0001, respectively. After reading the set and the motor speeds, the commutation thyristors are turned off and PID subroutine is called to implement control function.

This subroutine contains the multiplication routine which are required to multiply the calculated values of error, integral and derivative by  $K_p$ ,  $K_I$  and  $K_D$ , respectively.

After multiplication proportional and intergal error are added and the result is subtracted from the derivative error. The total error is obtained at the end of the calculations and stored in the  $\text{000E}$  and  $\text{000F}$ . All the calculations in the PID subroutine are done in 16 bit form.

After completing the PID subroutine, the processor checks the sign of total error. If the sign of total error is negative the processor enter regenerative subroutine and fires the main thyristor of chopper B and turns on the chopper B on. Otherwise, the processor enters motoring subroutine and fires the main thyristor of chopper A and turns chopper A on.

Chopper's on time is determined by the high byte of total error which is calculated at the PID subroutine.

Before going to the beginning of the program main thyristors should be turned off.

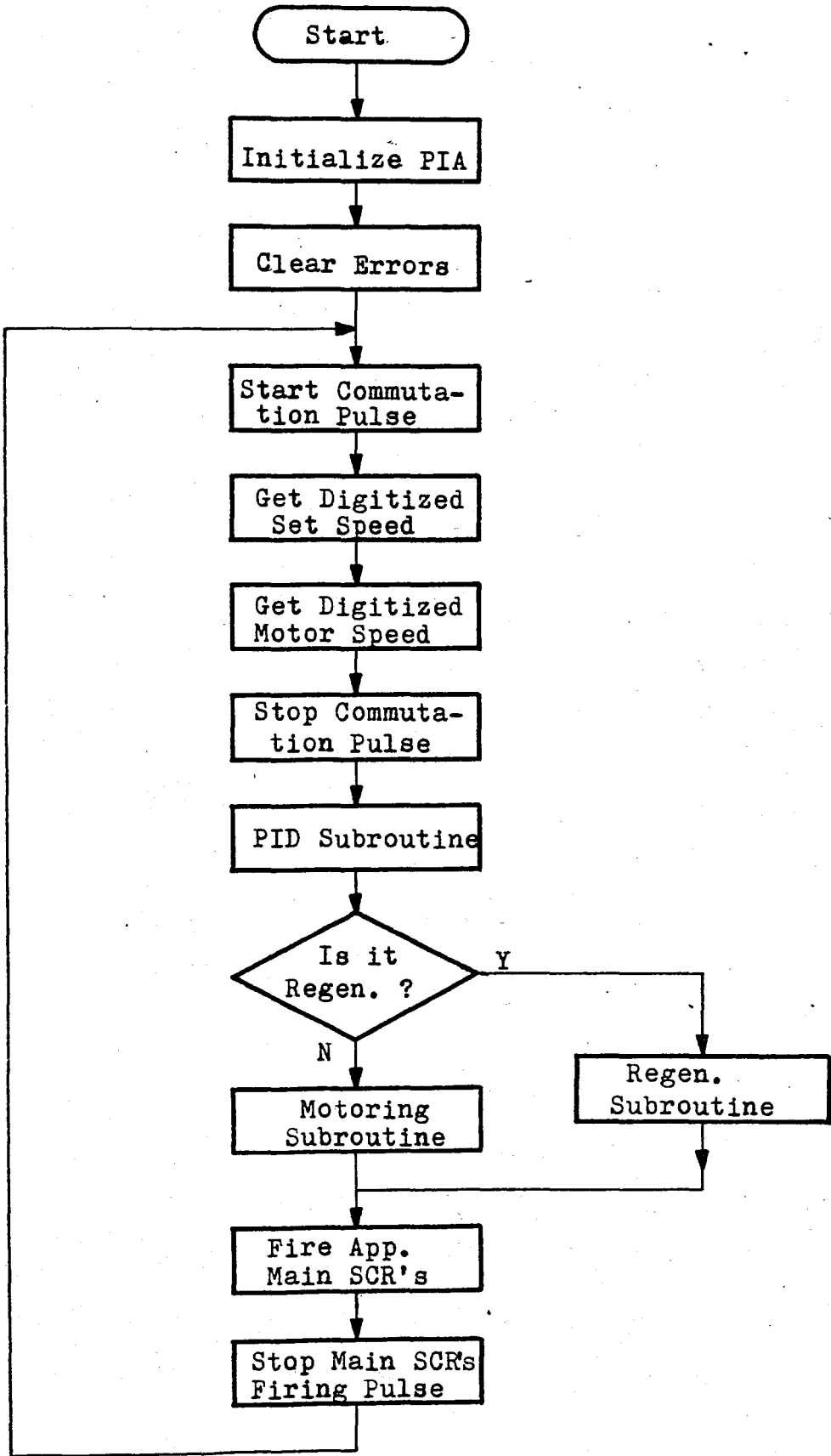

Figure 4.11 Flowchart

## CHAPTER 5

### SYSTEM EVALUATION and EXPERIMENTAL RESULTS

The practical capabilities of the system configuration considered here can be evaluated by inspecting the results given in figures in this chapter.

The solid line shown in figure 5.5 exhibit the response of system with zero differential constant. The set speed is accelerated from zero to 42H, then the motor speed will rise to the set speed in approximately 1 sec. The response of the system, to a steady-state loading and unloading is shown in figure 5.5. Figure 5.6 shows similiar responses with 80H differential constant.

It is seen that changing the derivative constant does not change the system response significantly.

Figures 5.7, 5.8 and 5.9 show the effect of changing the integral constant. Decreasing the integral constant decreases overshoot amplitude and increases the settling time.

The results (experimental) are found to be in good agreement with theoretical prediction.

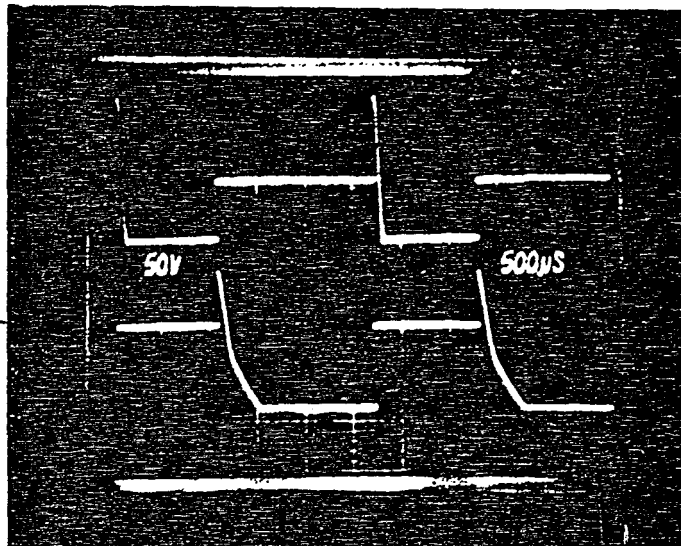

FIGURE 5.1

MOTORING .

Upper trace : Comm. thy. anode cathode  
voltage inverted

Lower trace : Main (motoring) thy. anode  
cathode voltage inverted

Lines on the left of picture zero reference

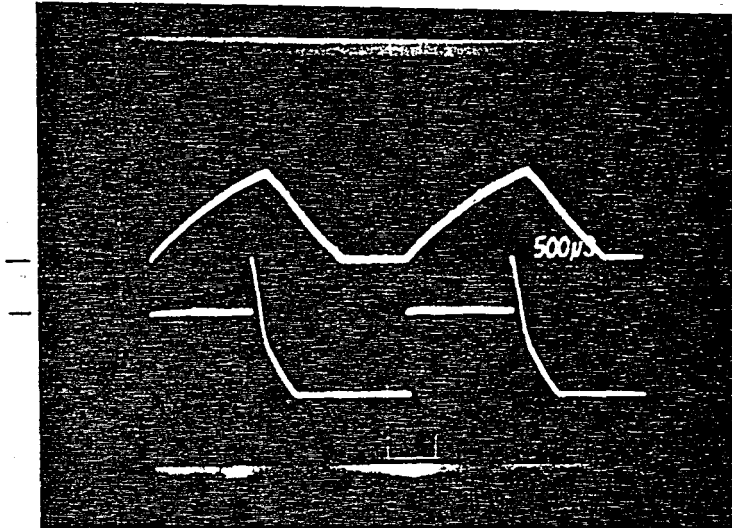

FIG.5.2

MOTORING NO LOAD

Upper trace : Armature current 1 A/div

Lower trace : Main thy. voltage inverted 50 V/div

Armature current discontinuous

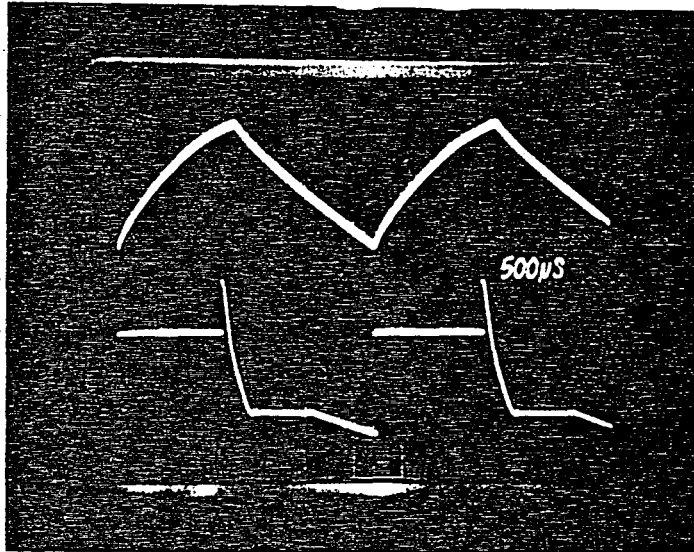

FIG. 5.3

MOTORING LOADED

Scale as in Fig.3

Continuous armature current

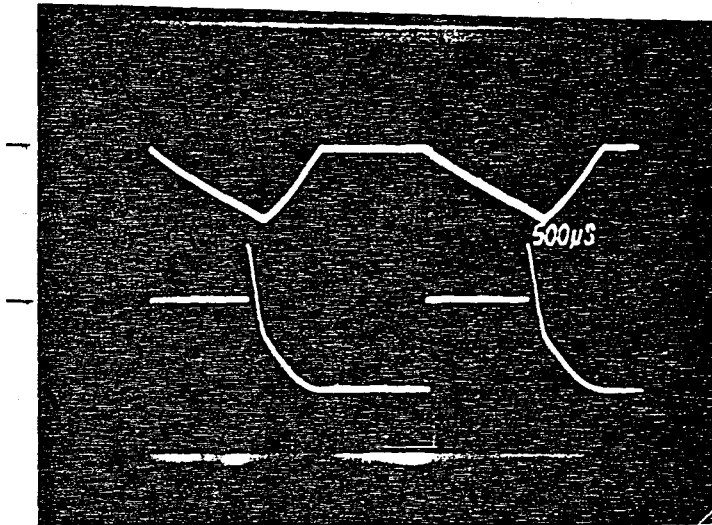

FIG. 5.4

REGENERATION

Upper : Armature current 1 A/div

Lower : Regen. main SCR anode cathode  
voltage (inverted) 50 V/div

FIG. 5.5

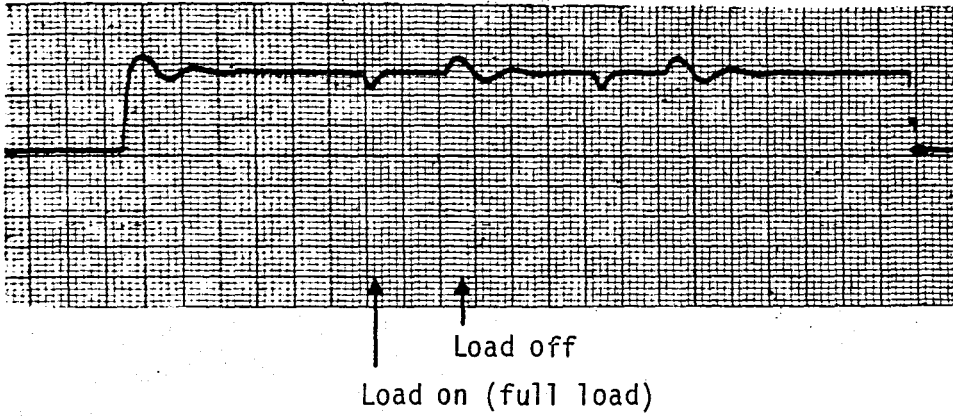

→ Acceleration from zero

$K_p: 80_H$ ,  $K_I: 04_H$ ,  $K_D: 00_H$

Chart speed : 5 mm/sec

FIG. 5.6

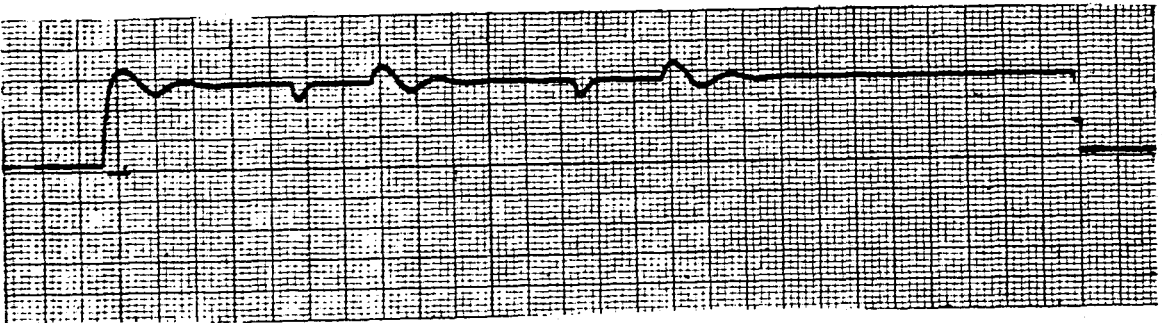

$K_p: 80_H$ ,  $K_I: 04_H$ ,  $K_D: 80_H$

Set speed :  $42_H$

Motor speed :  $42_H$

258 rpm.

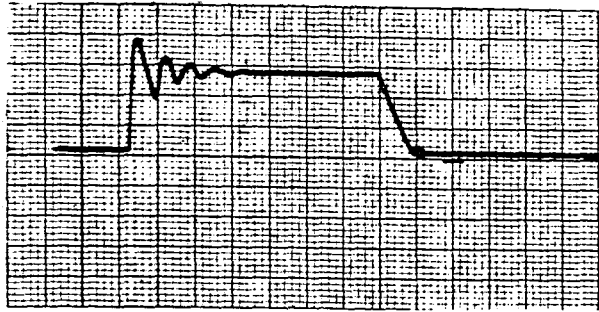

FIG. 5.7

$K_p: 80_H, K_I: 10_H, K_D: 00_H$

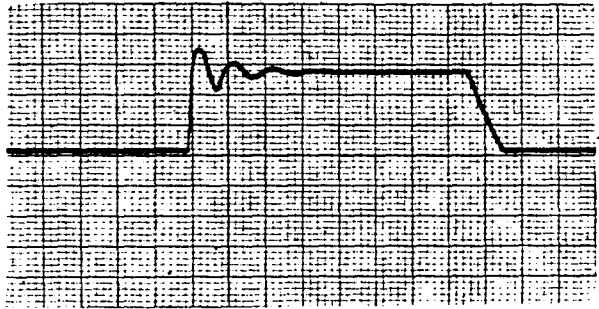

FIG. 5.8

$K_p: 80_H, K_I: 08_H, K_D: 00_H$

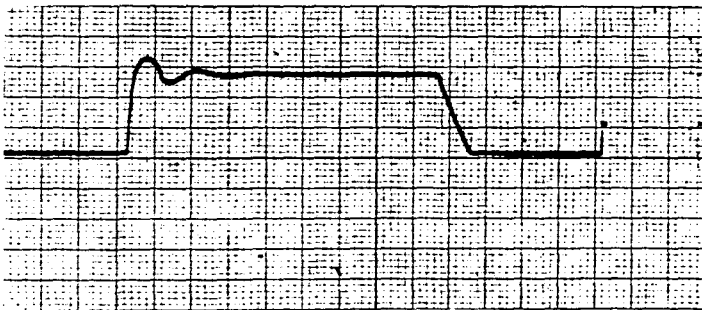

FIG. 5.9

$K_p: 80_H, K_I: 04_H, K_D: 00_H$

## CHAPTER 6

### CONCLUSION and FURTHER IMPROVEMENTS

The evidence in the experimental results confirm the efficiency of the propulsion system. Since the PID control algorithm is used, the steady state error as well as the deviation of the speed due to load disturbance are set to zero. The top speed goes up to maximum motor speed which is approximately 1000 rpm. This is an advantage for an electric vehicle in overtaking capabilities.

It is possible to use adaptive control which checks the system performance and changes control parameters which are stored in RAM. However, adaptive control cannot be done by using MC6802 as it will decrease the chopper rate considerably.

In order to upgrade the controller, the MC6801 can be used instead of MC6802. 6803's instruction set include six 16-bit operations on double accumulator (D). The double accumulator is a 16-bit accumulator made up of the A accumulator (which forms the 8 most significant bits of D), and the B accumulator (that forms the 8 least significant bits). Instructions using the double accumulator load, store, add 16 bits, subtract 16 bits and shift the double accumulator right or left. Three new operations manipulate the index register (X) as follows ;

1. Push X register (onto the stack),
2. Pull X register (from the stack),
3. Add accumulator to X register.

The push and pull of the index register allows quick temporary storage of the index register. The most interesting new instruction for 6803 is an 8-by-8 bit unsigned multiply that provides a 16-bit result in 10 sec. This instruction is 20 times faster than an implementation in 6800 software(Ref.12)

The cost of Perbury type CVT does not seem to be decreasing. So, instead of CVT, it is possible to employ the four quadrant chopper for reversible motoring or regenerative DC drive.

## REFERENCES

1. Andrew A. Frank and Norman H. Beachly, Evaluation of the Flywheel Drive Concept for Passenger Vehicles, Society of Automotive Engineers, Inc., February 26-March 2, 1979
2. M.T.G. Hughes, Automotive Power Systems Analysis and Control, Report on a Study Programme in the U.S.A, February 1977
3. Colin Anscomb, Evaluation of the Performance of Electric and Hybrid Vehicles, Department of Engineering, University of Warwick, August, 1981
4. Ömer CERİD and Ahmet DENKER, A Microprocessor Controlled DC Traction Drive for Electric/Hybrid Vehicles, Boğaziçi University, 1982
5. DC Motors, Speed Controls, Servo Systems, Electro-Craft Corporation, Third Edition, Pergamon Press, U.S.A, 1977
6. Alexander Kusko, Solid State DC Motor Drives, The MIT Press, 1969
7. P.C. Sen, Thyristor DC Drives, Wiley-Interscience, 1980
8. Microprocessors Data Manual 1982, Motorola Inc., Switzerland
9. Tim Henry, Successive Approximation A/D Conversion, Motorola Inc., 1974
10. Joseph D. Greenfield and William C. Wray, Using Microprocessors and Microcomputers The 6800 Family, John Wiley and Sons, Inc., 1981
11. Michael Andrews, Programming Microprocessor Interfaces for Control and Instrumentation, Prentice-Hall, Inc., Englewood Cliffs, New Jersey, 1983
12. MEK6802D5E Microcomputer Evaluation Board User's Manual, Motorola Inc., 1980 U.S.A.

APPENDICES

APPENDIX A	M6800 Instruction Set
APPENDIX B	Negative Circuit Layout Films
APPENDIX C	Circuit Diagram

ADDRESSING MODES

BOOLEAN/ARITHMETIC OPERATION COND. CODE REG.

OPERATIONS	MNEMONIC	ADDRESSING MODES										BOOLEAN/ARITHMETIC OPERATION (All register labels refer to constants)	COND. CODE REG.				
		IMMED		DIRECT		INDEX		EXTND		IMPLIED			S	O	Z	V	C
		OP	~	OP	~	OP	~	OP	~	OP	~						
Add	ADD	18	2	98	3	A8	5	B8	4			A + M - A					
	ADDB	CB	2	0B	3	EB	5	FB	4			B + M - B					
Add Acmltr	ABA									18	2	A - B - A					
Add with Carry	ADCA	89	2	99	3	A9	5	B9	4			A + M + C - A					
	ADCB	C9	2	09	3	E9	5	F9	4			B + M + C - B					
And	ANDA	84	2	94	3	A4	5	B4	4			A - M - A					
	ANDB	C4	2	04	3	E4	5	F4	4			B - M - B					
Bit Test	BITA	85	2	95	3	A5	5	B5	4			A - M					
	BITB	C5	2	05	3	E5	5	F5	4			B - M					
Clear	CLR					6F	7	7F	6			00 - M					
	CLRA									4F	2	00 - A					
	CLRB									5F	2	00 - B					
Compare	CMPA	81	2	91	3	A1	5	B1	4			A - M					
	CMPB	C1	2	01	3	E1	5	F1	4			B - M					
Compare Acmltr	CBA									11	2	A - B					
Complement, 1's	COM					63	7	73	6			M - M					
	COMA									43	2	A - A					
	COMB									53	2	B - B					
Complement, 2's (Negate)	NEGA					60	7	70	6			00 - M - M					
	NEGB									40	2	00 - A - A					
	NEGB									50	2	00 - B - B					
Decimal Adjust, A	DAA									19	2	Converts Binary Add of BCD Characters into BCD format					
Decrement	DEC					6A	7	7A	6			M - 1 - M					
	DECA									4A	2	A - 1 - A					
	DECB									5A	2	B - 1 - B					
Exclusive OR	EORA	88	2	98	3	A8	5	B8	4			A ⊕ M - A					
	EORB	C8	2	08	3	E8	5	F8	4			B ⊕ M - B					
Increment	INC					6C	7	7C	6			M + 1 - M					
	INCA									4C	2	A + 1 - A					
	INCB									5C	2	B + 1 - B					
Load Acmltr	LDA	86	2	96	3	A6	5	B6	4			M - A					
	LDAB	C6	2	06	3	E6	5	F6	4			M - B					
Or, inclusive	ORA	8A	2	9A	3	AA	5	BA	4			A + M - A					
	ORB	CA	2	0A	3	EA	5	FA	4			B + M - B					
Push Data	PSHA									36	4	A - Msp, SP - 1 - SP					
	PSHB									37	4	B - Msp, SP - 1 - SP					
Pop Data	PULA									32	4	SP + 1 - SP, Msp - A					
	PULB									33	4	SP + 1 - SP, Msp - B					
Rotate Left	ROL					69	7	79	6			M					
	ROLA									49	2	A					
	ROLB									59	2	B					
Rotate Right	ROR					66	7	76	6			M					
	RORA									46	2	A					
	RORB									56	2	B					
Shift Left, Arithmetic	ASL					68	7	78	6			M					
	ASLA									48	2	A					
	ASLB									58	2	B					
Shift Right, Arithmetic	ASR					67	7	77	6			M					
	ASRA									47	2	A					
	ASRB									57	2	B					
Shift Right, Logic	LSR					64	7	74	6			M					
	LSRA									44	2	A					
	LSRB									54	2	B					
Store Acmltr	STA			97	4	A7	6	B7	5			A - M					
	STAB			07	4	E7	6	F7	5			B - M					
Subtract	SUBA	80	2	90	3	A0	5	B0	4			A - M - A					
	SUBB	C0	2	00	3	E0	5	F0	4			B - M - B					
Subtract Acmltr	SBA									10	2	A - B - A					
Subtr. with Carry	SBCA	82	2	92	3	A2	5	B2	4			A - M - C - A					
	SBCB	C2	2	02	3	E2	5	F2	4			B - M - C - B					
Transfer Acmltr	TAB									16	2	A - B					
	TBA									17	2	B - A					
Test, Zero or Minus	TST					6D	7	7D	6			M - 00					
	TSTA									4D	2	A - 00					
	TSTB									5D	2	B - 00					

LEGEND:

- OP: Operation Code (Hexadecimal);
- ~: Number of MPU Cycles;
- =: Number of Program Bytes;
- +: Arithmetic Plus;
- : Arithmetic Minus;
- : Boolean AND;
- Msp: Contents of memory location pointed to be Stack Pointer;

- ⊕: Boolean Inclusive OR;
- ⊖: Boolean Exclusive OR;
- : Complement of M;
- : Transfer Into;
- 0: Bit - Zero;
- 00: Byte - Zero;

CONDITION CODE SYMBOLS:

- H: Half-carry from bit 3.
- I: Interrupt mask
- N: Negative (sign bit)
- Z: Zero (byte)
- V: Overflow, 2's complement
- C: Carry from bit 7
- R: Reset Always
- S: Set Always
- ! : Test and set if true, cleared otherwise
- : Not Affected

Note - Accumulator addressing mode instructions are included in the column for IMPLIED addressing



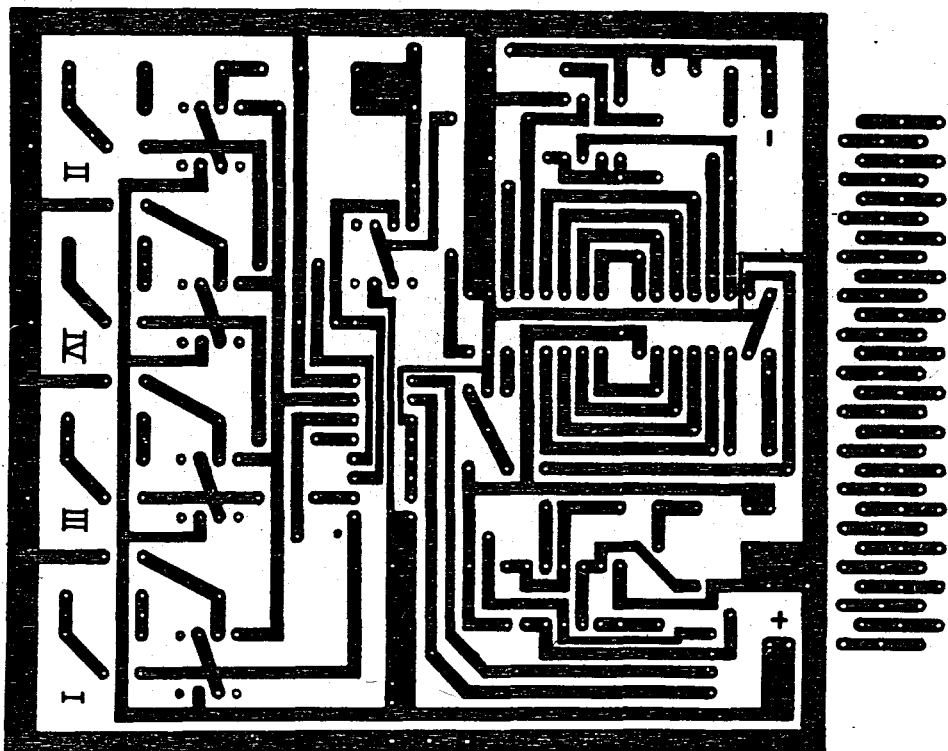
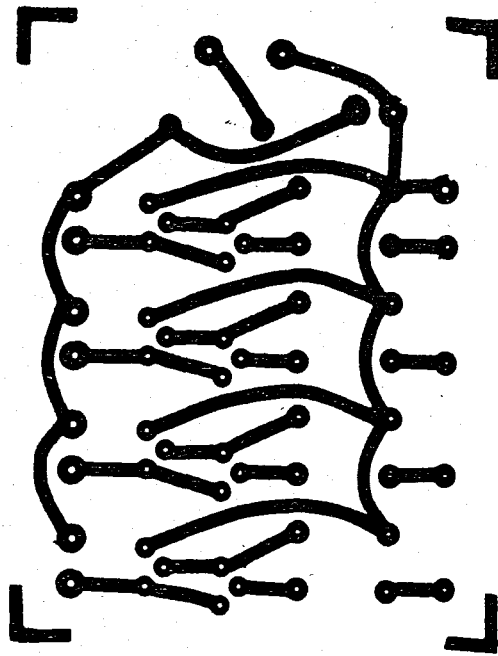

APPENDIX B

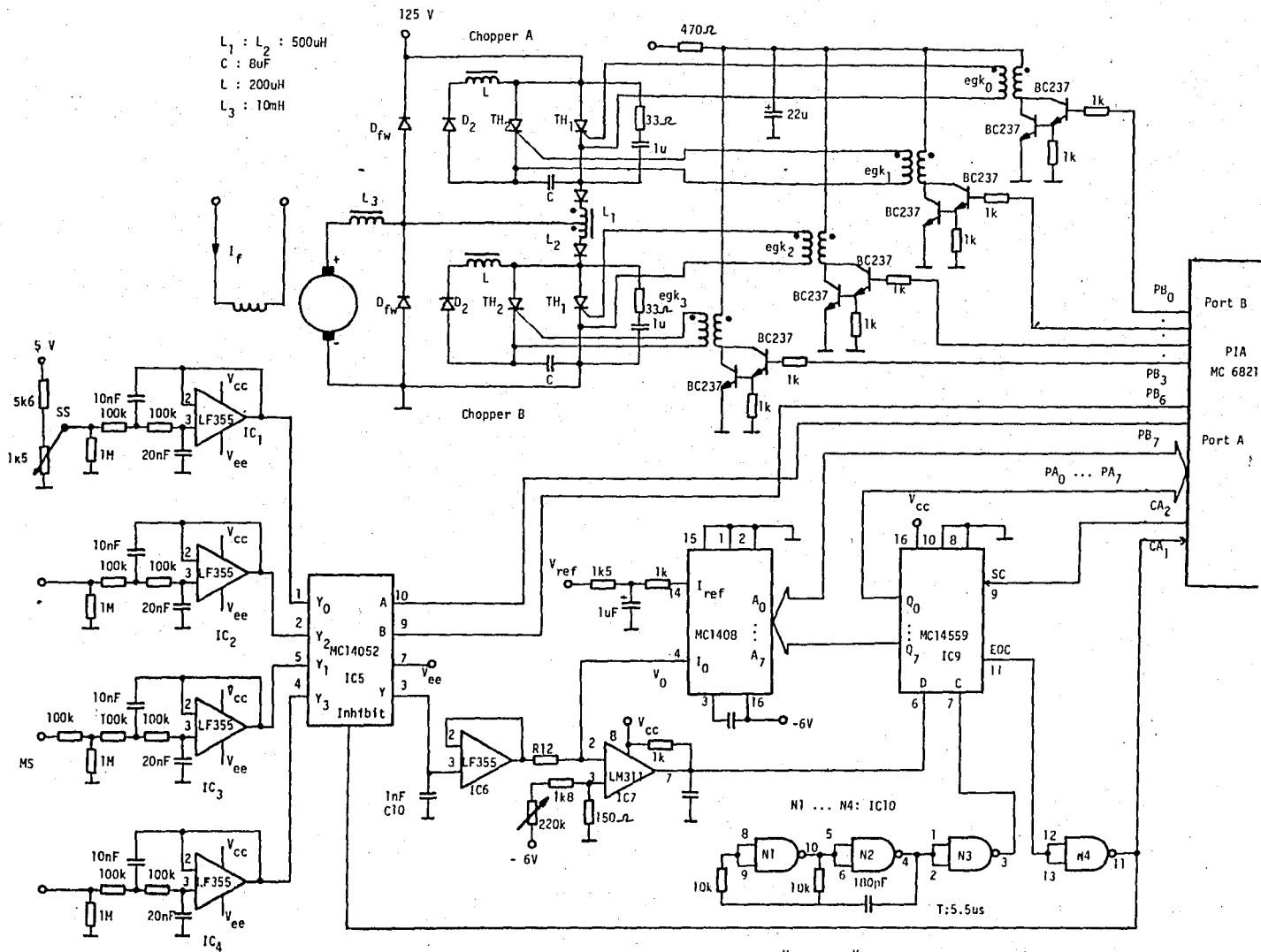

$$\frac{V_{ref}}{R_{ref}} = \frac{V_{FS}}{R_{12}}$$

$V_{FS} : 1.06 \text{ V}, R_{12} : 500$   
 $V_{ref} : 5 \text{ V}, R_{ref} : 2K5$