

**TACTILE MENTAL ROTATION IN BLINDFOLDED AND
CONGENITALLY BLIND SUBJECTS**

by

Betül Polat

BS, Biology, Marmara University, 2008

Submitted to the Institute of Biomedical Engineering
in partial fulfillment of the requirements
for the degree of
Master of Science
in
Biomedical Science

Boğaziçi University

2012

ACKNOWLEDGMENTS

First of all I would like to thank my advisor Assoc. Prof. Burak Güçlü for his valuable comments during the study.

I should state my thanks to Dr Aylin Çiftçi, from the Directorate of Handicapped People of Istanbul Metropolitan Municipality for her support and encouragement. I would also like to thank Mr Şevket Köseoğlu from Eyüp Library for the Blind. They received me kindly in different experiment sites they provided, brought me together with the volunteers and shared valuable comments. I could not have managed to complete my studies without their support.

I would like to thank my beloved friend Eng.Pinar Özel for her help with everything from building the setup from scratch to finally putting it all together with Latex. I should include my thanks to my dear friend Elif Kubat for carrying my set up upstairs and downstairs countless times and of course for encouraging me. I would also like to thank my dear friend Tuba Akgül whom we set to road of scientific career together years ago.

I would very much like to thank my family for their support and encouragements, especially my brother M. Said Polat for being there whenever, wherever, as well as for his artistic and technical support.

And last but not least, I should thank all volunteers one by one, who very kindly shared their valuable time, shared the joy of science with me. I could not have gone this far without their help and active support.

This work had been very enriching and rewarding, I would like to say thanks to all my new blind friends for opening the doors of a new perceptual world for me.

ABSTRACT

TACTILE MENTAL ROTATION IN BLINDFOLDED AND CONGENITALLY BLIND SUBJECTS

Mental rotation is the process of imagining an object rotated into a different orientation in space. This well-known visual phenomenon may be used to understand the cognitive processing by applying it to the tactile modality. Linear correlation between response times and angular orientations of the explored objects shows the mental rotation effect.

Twelve sighted, 12 congenitally blind subjects participated in this study. All subjects were right handed. Gender and age were balanced. The sighted were blindfolded through the experiments. Two tactile L-shaped objects were glued on cardboards as pairs rotated at five orientations (0° , 45° , 90° , 135° , 180°). A passive touch method was developed, subjects' hands were steady on a platform and objects were placed and lifted with a lever. Subjects used their palms to passively touch the objects. The subjects were instructed to explore the objects tactually and decide if the pairs were same or different – different meaning mirror as known to the experimenter. Response times and accuracies were recorded. Correlation analysis and ANOVA were performed using Matlab. Results showed that both the blindfolded and congenitally blind subjects used mental rotation process during tactile exploration of the stimuli.

The results support the idea that an analog representation is used in the cortex which totally lacked visual input. The data presented in this study, combined with the literature further supports the hypothesis that spatial properties of the objects are encoded similarly for touch and vision.

Keywords: Object recognition, blindness, touch.

ÖZET

GÖZÜ BAĞLI VE DOĞUŞTAN GÖRMEYEN DENEKLERDE DOKUNSAZ ZİHİNDE DÖNDÜRME

Zihinde döndürme, bir cismin zihindeki temsilini döndürme sürecidir. Bu iyi bilinen görsel olgu, dokunsal modaliteye uyarlanarak kognitif süreçleri arařtırmakta kullanılabilir. Uyarılar arasındaki açđ farkđ ile cevap verme süresinde gözlemlenen doğrusal artış zihinde döndürmenin etkisine işaret eder.

Bu tezde 12 görebilen, 12 doğuştan göremeyen katılımcđ ile çalışıldı. Tüm katılımcılar sağ ellerini baskın olarak kullanan kişiler arasından seçildi. Yaş ve cinsiyet gruplar arasında dengelendi. Görebilen katılımcıların gözleri deney boyunca bađlı tutuldu. İki dokunsal ahşap L-şeklinde obje aynı, ya da birbirinin ayna görüntüsü olmak üzere, yatay düzlemde 5 farklı açıda (0° , 45° , 90° , 135° , 180°) hazırlandı ve kartonlara yapıştıırıldı. Deney boyunca katılımcıların ellerinin sabit kalmasını sađlayan bir pasif dokunma metodu geliştirildi ve objeler mekanik bir kaldıraç vasıtasıyla katılımcıların avuçlarına deđdirilerek iki cismin aynı mı yoksa farklı mı olduklarını belirtmeleri istendi. Burada farklı yanıtı ayna görüntüsü anlamını taşımaktadır. Deneklerin yanıt süreleri ve yanıtlarının doğruluđu kaydedildi. Verilere MATLAB programında korelasyon analizi ve ANOVA uygulandı. Sonuçlar gözü bađlı ve doğuştan görmeyen grupların her ikisinin de dokunsal uyarıları incelerken zihinsel döndürme sürecini kullandıklarını göstermektedir.

Bu sonuçlar analog bir temsilin görsel bilgiden tamamen yoksun bir kortekte de işlenebildiğini göstermesi açısından anlamlıdır. Literatürde konu ile ilgili diđer veriler de göze alındığında; uzaysal bilginin hem dokunma hem de görme bölgelerinin ortak işleyebileceđi bir zihinsel şablon olarak kaydedilip sonradan zihinsel döndürme gibi süreçlerde kullanılabilirdiđi bulunmuştur.

Anahtar Sözcükler: Dokunsal zihinsel döndürme, obje algılama, körlük.

TABLE OF CONTENTS

ACKNOWLEDGMENTS	iii
ABSTRACT	iv
ÖZET	v
LIST OF FIGURES	viii
LIST OF TABLES	ix
LIST OF SYMBOLS	x
LIST OF ABBREVIATIONS	xi
1. INTRODUCTION	1
1.1 Motivation and objectives	1
2. THEORETICAL BACKGROUND	3
2.1 Object recognition	3
2.1.1 Mental rotation	4
2.1.2 Tactile mental rotation	7
2.1.3 The case of blind subjects revisited	8
2.2 Processing spatial information in different sensory modalities	9
2.2.1 Combining modalities: Reference hypothesis	11
2.2.2 Perspective, projection and pictures	14
2.3 Cerebral cortical processing : Functional neuroimaging studies	15
2.3.1 Somatosensory areas	16
2.3.2 Motor areas	17
2.3.3 Visual areas	18
3. METHODOLOGY	20
3.1 Participants	20
3.2 Materials	21
3.2.1 Objects	21
3.2.2 Tactile platform	23
3.3 Procedure	24
3.4 Analysis	24
4. RESULTS	26

4.1	Accuracy	26
4.2	Response time	27
4.3	Mental rotation test	28
4.3.1	Slopes and intercepts	30
5.	DISCUSSION	32
5.1	Accuracy	32
5.2	Response time	33
5.3	Mental Rotation	34
5.3.1	Establishing a process model	34
5.4	Functional imaging studies	36
5.4.1	A verbal or semantic processing	37
5.4.2	A single representation for both modalities	37
5.4.3	Blindness unmasking the brain's naturally suppressed abilities	38
5.5	Limitations of the study	41
6.	CONCLUSION	43
6.1	Future Work	44
	REFERENCES	45

LIST OF FIGURES

Figure 3.1	Dimensions of the objects	22
Figure 3.2	Stimulus types. a and b include the 'same' stimuli, c and d include the 'different' stimuli (mirror image).	22
Figure 3.3	Stimuli. Since there are no distinctive features of shapes to differentiate, subjects rotated either object on the picture plane to acquire a match. The absolute value of the angular difference was probably mentalized.	23
Figure 3.4	Experimental setup	23
Figure 3.5	The lever mechanism	23
Figure 4.1	Percent accuracy in sighted and blind subjects	26
Figure 4.2	Linear relationship between angular difference and percent accuracy for sighted and blind subjects	27
Figure 4.3	Mean response times of the same and the different stimuli for blind and sighted subjects	28
Figure 4.4	Linear relationship between angular difference and mean response times for all stimuli (same and different).	29
Figure 4.5	Linear relationship between angular difference and mean response times of only the same stimuli.	30
Figure 4.6	Linear relationship between angular difference and mean response times of the different stimuli.	30

LIST OF TABLES

Table 3.1	List of sighted participants	20
Table 3.2	List of blind participants	20
Table 3.3	Cause of blindness	21
Table 4.1	Correlation of accuracies for sighted and blind subjects.	27
Table 4.2	Correlation of response times versus angles for sighted and blind subjects; all stimulus included.	28
Table 4.3	Correlation of response times versus angles for sighted and blind subjects, only the same stimuli are included.	29
Table 4.4	Correlation of response times versus angles for sighted and blind subjects, only the different stimuli are included.	29
Table 4.5	Linear relationship formulas of sighted subjects for three stimulus types.	31
Table 4.6	Linear relationship formulas of blind subjects for three stimulus types.	31

LIST OF SYMBOLS

r	Correlation coefficient
α	Level of significance
p	Probability value
\circ	Degrees

LIST OF ABBREVIATIONS

s	Seconds
cm	Centimeter
ANOVA	Analysis of Variance
RT	Response Time
TMS	Transcranial Magnetic Stimulation
rTMS	Repetitive Transcranial Magnetic Stimulation
fMRI	Functional Magnetic Resonance Imaging
ERP	Event Related Potentials
GOT	Grating Orientation Task

1. INTRODUCTION

1.1 Motivation and objectives

Mental rotation is the rotational transformation of an object's mental representation. It is a clear-cut finding in object recognition theory. In daily life, we encounter familiar objects in an endless series of orientations. Single-view-plus-transformation theory suggests that the most familiar representation is coded as a template and then is used to transform and match during the day to recognize objects.

It may be tested in a task in which two stimuli are compared to be identical or mirror images. When the task is done visually, it was seen that the reaction time increases linearly with the angular difference between the presented stimuli.

In this study it was hypothesized that exploration of tactile stimuli would yield similar results in the sighted as well as congenitally blind participants. Of many studies the literature holds, the question whether the blind are using the same mental processing to complete this task remained controversial. By applying the mental rotation experiment to tactile modality we aimed to observe the effect of different input modalities to tactile object recognition and to understand the effect of the lack of visual input.

To test this hypothesis we built a tactile setup and asked congenitally blind and blindfolded participants to decide if two simultaneously presented stimuli are the same or different. The objects were either the same or mirror images of each other, glued on a surface in different angular orientations. Linear increase with angular orientation would show the mental rotation effect.

In Chapter 2 we give the theoretical background of literature on which we built our hypothesis. The chapter starts with a brief introduction on object recognition

theories and continues with mental rotation transformation. In the second part, we give information on the common properties of touch and vision by reviewing the literature on studies with the blind. Finally we summarize the accumulated data on the activation of brain areas during tactile discrimination of form and space.

In Chapter 3 we describe our methods and in Chapter 4 numerical results are presented. Finally in Chapter 5 we discuss the results along with previous psychophysical and functional imaging studies. Some new directions for the study are proposed in Chapter 6.

2. THEORETICAL BACKGROUND

2.1 Object recognition

Everyday mental capacities such as perceiving a cup of coffee on your desk or remembering an old friend is the product of underlying complex structures of sub-processing and have caught the interest of cognitive scientists since the early years. To separate and analyse these processes and to understand how they are interconnected; scientists came up with many cognitive tasks; applied on normal and abnormal subjects or sometimes even by means of leaving normal subjects under abnormal situations. All this hard work has sometimes been described as “carving mind at its joints” [1]. Vision is one of the main areas of work and it is of great complexity. Oliver Sacks at a paper dated 1985 claimed that a patient’s vision was so disturbed that he mistook his wife for a hat [2]! That is rather extreme, yet many other similarly bizarre behavioural dysfunction has been documented, and being able to work on these subjects helped researchers have an understanding of how visual system normally works.

We are able to recognize objects despite the difference in their retinal projections when they are seen at different orientations. Literature holds different theories on how this process works [3]:

i. Viewpoint-independent model: This model includes feature models in which objects are represented as collections of spatially independent features, or the structural description models, in which shapes are stored in memory as structural descriptions regardless of their orientation. This model leads to the descriptivist hypothesis [4].

ii. Single view plus transformation model: Shape information may be represented in the memory as a single, widely used – possibly canonical- representation, and series of transformations are used to analyse and compare the objects seen to their canonical representation. This model is the ‘mental transformation hypothesis’.

iii. Multiple view model: Shapes may be stored in a set of representations for different orientations. This is the 'multiple view hypothesis'.

The time required to recognize an object also varies according to each model. The viewpoint independent models and multiple views models suggest that the amount of time required to recognize an object will not change with the orientation. The single view plus transformation model, as the name suggests, recognition time depends on the orientation. The object should be transformed into the nearest stored version to acquire a match, so the recognition time will monotonically change with the orientation.

2.1.1 Mental rotation

A dreamlike vision of “a spontaneous kinetic image of three dimensional structures majestically turning in space” [5] led Roger Shepard, Lynn A. Cooper and Jacqueline Metzler to study the analogue transformation process which they called 'mental rotation' [6].

If a single representation is stored and then processed in the brain, when a rotated version of the stored object is encountered, it should be rotated around an axis to get a match with the predefined mental template. As well as its size, color, luminance, texture information can be mentally processed. Shepard et al. have done a series of visual reaction time experiments which explored the relationships between the structure of internal representations of objects (the mental image) and the structure of external stimuli which they correspond to.

1- Subjects were asked to discriminate standard images from mirror images. The time they took to explore visually increased monotonically for orientations further from upright, and was not longer for a rotation in depth than for a rotation in the picture plain. At the introspective reports all eight subjects claimed that they imagined rotating the object in their minds, at no greater than a certain limiting 'rate of rotation' [6].

2- When subjects were provided with information about the upcoming stimuli, the time it took to decide for handedness of the stimuli was relatively invariant across orientations [6].

3- When the objects were given with a probe stimulus, the reaction time was insensitive to the absolute canonical orientation but was related to the instantaneous orientation of the stimuli [7].

4- When subjects were extensively trained for a given direction, the recognition time was also bimodally distributed with peaks corresponding to the long and short way around [5].

The process model of this compiled work suggested that subjects generated mental templates of the objects first, rotated the internal template when stimulated with the new external stimuli and made the comparison of same or different by match/no match and reported the decision.

While mental rotation shows proof for single view plus transformation model of object recognition, it is found to be used to assign handedness rather than recognize shapes [8, 9]. Hence the mirror image concept has then been used repeatedly in mental rotation tasks for it prevented the subjects to discover distinctive features of objects when determining if they were same or different, but obliged them to rotate the objects mentally till they got a match

An issue taken into consideration is the familiarity of the object being rotated and the initial trained orientation's effect to rotation rate. 2D Images of novel objects with different complexity points were used on sighted subjects but complexity effect did not seem to change the response time [10]. Later the author reported the possibility is that the internal representation of the visual form was highly schematic in comparison with the rich detail of the form itself [7]. The subjects were also provided with pre-information about the identity and orientation of the upcoming stimulus; the time required to prepare for the onset of that test form linearly increased as a function of

angular departure from the previously learned orientation. The rate of rotation seemed rapid and constant.

Evidence shows mental rotation is used not only for left-right but also up-down mirror discrimination [8]. But mental rotation took longer time in case of up-down discrimination for there is abundant evidence that left-right reflection of a pattern is much more equivalent perceptually to the original than is the up-down reflection [11]. It is suggested that bilateral organisms that did not differentiate its own right from left could not perform mental rotation tasks in which mirror image discrimination is essential [12]. So it is discussed that one could be aligning the stimuli to his own bodily coordinates and refer them to their own left-right axes [13]. Parsons presented the participants with actual drawings of rotated left and right hands; as an effect of embodiment as he discussed, the subjects were slower to rotate in directions incompatible with the way human wrist rotates [14].

Some researchers also suggested that what is rotated is the frame other than the stimuli itself. But the response times showed evidence of greater dependence on the image/object rotation both on single letter stimuli and word-like stimuli and there was no evidence on existence of individual differences in the tendency to rely on the frame rotation rather than object rotation [15].

Evidence shows mental rotation is not always coded in a hand centered frame of reference but could be body centered or even head centered [16]. Faster clockwise than counter-clockwise rotation for both visual and tactile alphanumeric stimuli was recorded. [17, 18]

IQ data of the subjects showed that the higher the IQ, the faster the speed of mental rotation gets [19]. Left hand RT (of right handed subjects) was significantly shorter than right hand ones across all angular orientations showing right hemisphere dominance on the task [20].

There is a general agreement that mental processing is composed of functionally

distinct stages [21]. How are these processes are interrelated? One proposal is that one process starts when one other is finished, in a discrete fashion [22]. Another view is the continuous stages of processing, that information is transmitted continuously from one stage to the other even if is incomplete as a continuous flow [23]. In a review paper Miller discusses the possibility that the results can not be explained by strictly continuous models. He suggests an alternative discrete coding (ACD) model [24] that only separate information processing (like coding for shape and coding for color) can be transmitted independently. Preliminary information could be transmitted and used immediately so stage N might be simultaneous with stage N-1 [25].

Continuous flow of information models are tested directly on visual mental rotation task where two sets of stimuli, one easy to perceive while one harder to perceive are given to the subjects in different angle orientations. Subjects are asked to decide what the stimuli are and if it is the mirror image or not. On a second block the same stimuli are now presented in different colors also in blocks easy and hard to discriminate. It is hypothesized that perceiving and rotation stages overlap, which would be an evidence for the continuous flow model, and they checked the responses for any under-additivity. The data gave out only a limited amount of under-additivity for both blocks so the author discussed a third partially overlapping model [26].

2.1.2 Tactile mental rotation

The question of whether mentally rotated forms should be coded as visual images or not, led scientists to the studies with the blind, using tactile stimuli.

Marmor and Zaback presented three groups of subjects; early blind, late blind and blindfolded sighted with a set of tactile objects and asked them to indicate whether the pair of stimuli was same or different. Once more the reaction time increased linearly with the angular departure from the upright orientation suggesting that visual imagery is not a necessary component of mental rotation [19]. Yet the speed of rotation in both late blind and the blindfolded surpassed the early blind. So they discussed that visual

imagery may not be an essential part of it yet it may make the mental rotation easier.

In many studies, researchers present two stimuli so the subject can compare and the memory effect could be eliminated. But on their work where they ask if the mental rotation task is spatial rather than its relation to visual imagery, Carpenter and Eisenberg presented only one figure at a time so that no time was lost to match up corresponding features [17]. Once again results indicated visual representation of the stimulus was not necessarily needed for mental rotation and it can operate on a non-visual fashion. Moreover, contrary to the previous work, Carpenter and Eisenberg found out that the blind subjects showed much lower reaction time for the upright stimulus which they explained occurred due to their familiarity to haptic tasks in everyday life. Second contrast this paper indicates is the curvilinearity effect seen with blindfolded subjects. They suggested that this could be because the stimuli were alphanumerical figures, and sighted subjects deal with them in upright or close-to-upright orientation every day. This results in some critical angle varying from subject to subject, generating curvilinearity rather than the linearity seen in the blind. Another explanation is that sighted-blindfolded subjects spent time on a different process: converting the haptic input to visual data. Blind subjects again did not do that. One last discussion was that, what is coded as the upright stimuli could be accorded to the position of the hand, body or some external frame of reference in haptic perception of the object. On a set of experiments the subjects' hands and arms were controlled. Response times for bent condition shifted relative to those in straight position. Carpenter and Eisenberg concluded that the spatial component of the mental rotation is the leading modality; rather than visual or haptic components [17].

2.1.3 The case of blind subjects revisited

On a previous thesis [27], mental rotation was studied with three groups of subjects: blind, blindfolded and sighted. The sighted performed the task visually while the other two groups used their hands and explored tactually. Three wooden tactile objects were glued on cardboards with the leftmost as the standard object.

The other two were normal and mirror objects. Each object was rotated randomly at five orientations. All experimental stimuli definitely had the mirror stimuli so the subject were instructed to find the 'same' stimuli. As expected, blind were the slowest to respond with most errors while sighted who performed visually yielded the lowest reaction times and minimum errors. The linearity effect which was shown to be a proof of use of mental rotation process was found for the sighted and the blindfolded groups. However no linearity was recorded for the blind. The graphs showed a non-linearity in a non-monotonic fashion. When the angle information was controlled, it was seen that the response time for high angular orientations were non-monotonically decreased with respect to the standard linear high values one would expect. With this result the authors suggested that congenitally blind subjects also used mental rotation but in a different fashion. The original mental rotation process model was such that when a stimulus was presented, a template of that exact shape was formed, then the upcoming stimulus was compared to that first one. Angle information was extracted and comparison was done by rotation. If no match was found, second stimulus was found to be the mirror image of the first one. The reaction time versus angular difference graphs of the blind, on the other hand called for a second model which they called the 'extended model'. According to that model the coding of the first stimulus as a template in the brain was done differently. The anti parallel canonical version of the stimulus was also extracted, so the angle of the upcoming stimulus was reduced, which could be the explanation of the smaller reaction times on larger angles. This process seems to require a higher cognitive load, so it might be the explanation of higher reaction times of the blind subjects [27].

2.2 Processing spatial information in different sensory modalities

How humans process spatial information is one of the central issues of cognitive neuroscience. There is little doubt that vision is normally the dominant modality for spatial cognition, yet it can also be accepted that touch provides somehow substitute

information with lack of vision. Current research evidence shows that while it may be helpful, vision is not necessary, since congenitally blind subjects perform much like blindfolded sighted subjects in picture perception [28], matching tasks and in tasks that require spatial reasoning and even in drawing pictures [29, 30]. What do different sensory modalities contribute to spatial thinking in these two distinct groups of perception and more importantly, how do they relate to each other?

Traditional classification of sensory input modalities into proximal and distal may not always provide useful information when trying to determine modality effects to spatial processing. One can suggest that haptic space – being proximal – is centered on the body while vision – a distal sense – is centered on external coordinates [31].

Although very roughly, this view suggests that haptic (touch and movement) information can still be processed to acquire spatial information in blind individuals, generating input from proprioceptive, gravitational and kinaesthetic cues. Nevertheless, the view that spatial coding of haptic input operates only within a proximal space needs to be tested.

We have evidence that touch can provide information when vision is lost, yet it has a limited field of view and processing of spatial information occurs sequentially so it may place a burden on memory. Touch is found to be much slower in many experiments. It has been argued similar to vision it can be used to understand perspective [29].

Yet touch may be expected to have clear advantages over vision for the perception of 3-D forms, when they are not limited to the fingertip. When grasping an object, one can acquire information about many sides of the object simultaneously. However, it is still a question of scale; very large objects and scenes cannot be grasped tactually.

Perspective varies as a function of viewing distance, so is therefore related to vision [32]. Imagery of congenitally blind cannot be expected to follow the laws of perspective [33]. Yet it was reported that blind people can understand and use perspective [29]. More recent research shows congenitally blind can understand and interpret some

aspects of perspective with little or less prior instruction [32], when exploring drawings of intersecting planes [34].

Touch indeed may be weak in picture interpreting because raised-line configurations of objects are not ecologically valid [35]. Moreover generating answers about tactile raised line shapes is argued to be calling for back-up visual imagery. Heller et.al presented series of pictures in a picture matching test, where visually impaired not only succeeded but also performed faster than the blindfolded [32]. This substituted evidence that visual imagery is not a requirement but may be beneficial for very low vision subjects who had the higher accuracy scores.

Perceptual selectivity is the ability to sort a figure from the ground and is deeply studied in vision literature. The process is thought to be a high level cognitive function [36]. Visually impaired subjects including the congenitally blind are known to perform haptic perceptual selectivity on raised-line embedded figures test after prior instruction and a learning session [37].

Studies with haptic objects, shapes and pictures provide researchers “a window through which we may evaluate spatial reasoning in blind” [38].

2.2.1 Combining modalities: Reference hypothesis

The information about the environment reaches to the human brain through many gates. An object’s distance can be seen, as well as it can be interpreted by the sound it makes. A surface’s roughness may be observed by seeing it and felt by touch. How does brain organize bits of information from different modalities in order to come up with a decision? For this study, related to touch and effects of visual system to touch, the reference hypothesis can be taken into consideration which suggests that the brain continuously operates spatial processing as organizing and integrating inputs to act as a reference cue from whatever source available [30, 39]. Further assumption is that spatial accuracy depends on the congruence of inputs from diverse sources of

reference cues which can be roughly categorized and tested as: body-centered, external \ environmental and object-based sources. A discrepancy in the inputs results in confusion, wrong answers or as will be further discussed ‘illusions’.

Common factors in perceptual illusions are known to exist in both touch and vision. Millar et.al studied this phenomenon thoroughly. One of the illusions known is veering in 3D space. Sighted people are known to experience this underwater or under dense fog while blind are generally known to lose direction and deviate from straight trajectory thinking they are still moving directly. It happens when one or more of the reference cues are lost. When for instance external cue sound is coupled with other cues; blind and sighted subjects are known to be able to walk straight to \ away from the source [40]. Another factor tested was the irrelevant posture cues. When for instance, the subjects were asked to carry a bag or a walking stick, they showed a tendency to lean towards the opposite side, seemingly for balance. These results contribute to the reference hypothesis. Either external or internal, when the reference cues are congruent, they are being more effectively facilitated for the task regardless of the modality of the input source.

Another common illusion in touch and vision is the Müller-Lyer Illusion. Müller-Lyer shapes consist of shafts and wings that either diverge from or converge to the shaft piece. Diverging winged shafts are perceived larger than the converging ones of same size; whether presented horizontally or vertically in vision. Blind subjects were asked to explore the shapes by touch. This commonly known optical illusion occurs in both vision and touch even in complete blindness [41]. Touch being more local whereas vision is global, it takes time to scan one shape by touch. Therefore, to test for the relevance of results to the reference hypothesis, some other possible causes of the illusions, movement time and tactile lack of distinctiveness of wings from shafts were taken into consideration along with use of external background cues since they occur in the visual condition [42]. The illusion was observed for small stimuli as well as big, and as in vision it increased as the wing angle reduced. The results are important that any of the factors did not reduce the illusion (speed of scanning, different angled shafts and fins and external frame). Only the explicit use of body-centered reference cues

seemed to reduce the illusion in both blind and sighted groups. Therefore, the same experimental manipulation produced similar effects in both modalities. The common factor was the instruction to use the body-centered cues to judge the shaft sizes.

Touch and vision may lead to illusions also for different reasons. Many illusions are thought to be linked to visual experience like misapplied size-constancy scaling [43]. But since found in congenitally blind subjects, Veering or Müller-Lyer cannot be about visual imagery. However, not all optic illusions are applicable to haptics.

Blind and sighted conditions differ mainly in reference information they provide. Visual information comes with a background and hence with a high amount of external reference cue. Can the difference in information be removed by providing the right set of cues or is it directly determined by the sensory input modality?

If the haptic space perception is modality specific and determined by body centered information providing external reference cues either should have no effect or decrease the chance of accurate perception. In contrast, according to the reference hypothesis, regardless of the source of information or the processing modality, congruency of inputs should improve the spatial processing accuracy. A raise-line table-top tactile map of rooms were used in different rotation orientations and different external frames with blind subjects [44]. The results were consistent with reference hypothesis. External frame cues compensated for body-centered references when they were not available, and when both external and body-centered cues were present, they had an additive effect on each other resulting in better accuracy. This suggests that explicit body-centered reference may be particularly effective for overriding the discrepancies that produce illusions while external cues may facilitate for higher spatial accuracy. The findings show that the difference in the nature of the information is not a necessary condition for input modality. This additive effect evidence clearly draws two modalities somewhat closer, dissolving the link between haptic to body centered cues and vision to external cues. Therefore, the common factor for space and shape coding by touch and vision can be best described as organized inputs as reference cues regardless of the source of inputs. It would hence be plausible to think that brain may have

a multifunctional, multi-modal area which can make use of information from different modalities.

2.2.2 Perspective, projection and pictures

Blind individuals are known to be able to draw outline raised-line pictures [29]. This phenomenon may be used to challenge theories of neural basis of perception and spatial cognition. The processing includes dealing with reverse projection from 2-D pictures of shapes back and forward to 3-D real-life objects. Novel theories offer different approaches like grouping and dots (a receptive field theory), facilitation of haptic and visual pathways (dedicated or flexible theory) and projection (a perspective band theory).

According to Kennedy et al, who had long studied with the blind, haptic vantage point may be assigned with 6 degrees of freedom. At any origin, palm can face right/left, up/down, forward/back. Moreover location can be rotated and moved in x-y-z dimensions, which can be referred to as transforming the movement. This haptic coordinate system can be applied to practice. Awareness, occlusion and surface boundaries can hence be explored, from different haptic point of views and hence the spatial properties, front/back and divisions can be understood [29].

Surface, vantage point and perspective are mainly needed for 3-D information. In vision, all objects are perceived from two vantage points simultaneously (stereopsis) and across time (motion). Similarly, since infancy the 6DF vantage point would lead one to produce related products of 3-D space in self-organizing systems.

Contact with a surface involves compression, shear forces, perpendicular forces and sometimes time, when motion is involved. The compression and pressing force indicates the firmness and rigidity of the surface while lateral forces provide friction, smoothness. Perpendicular forces like fingers or body parts posture give information about the shape and curve [45].

Perceptual grouping is a subject of Gestalt psychology. According to this theory, a line of dots are perceived as a continuous edge or a corner [46]. In a movement based haptic object or raised line figure recognition task, each moment of contact is grouped and aligned with the immediately prior contact [45]. Thus, grouping and continuity can be assigned, leading to the 3-D perception in both modalities.

Once continuity is depicted, what shape it traces can be the next question. Vision is about luminance, color, stereopsis and motion. After these input draw a border, putting these borders together is kind of flexible. Key features are used to subtract the object information. Like vision, touch must allow flexibility, because it deals with different patterns and conjunctions.

2.3 Cerebral cortical processing : Functional neuroimaging studies

To summarize up to this point, blind are known to be able to succeed analog processes to some extent. Some naturally attributed to vision processes can be applied to touch. These two distinctive modalities are known to share some illusions and most importantly, they both serve in the acquisition of similar information: recognition of 3D space.

These can be studied further by exploring the related brain areas. Perceptual brain areas have top-down and bottom-up input. Top-down design includes perception, is highly cognitive and is a result of not only stimulus but also internal hypothesis and expectation. It is assigned to search for feature targets in the input. Moreover it is required to be the product of certain bottom-up processes which are related to the original capturing of the input information.

Temporal–parietal–occipital junction is a high-order station that is helpful in cognitive functioning [47]. The superial colliculus is a relatively low-level station with

spatial sensory maps for audition, vision and touch, serving eye movements. These top-down areas might get dominant and detailed if the bottom-up processes are eliminated in the blind [48]. Areas of operation are ordered as the following. There are specialised regions activated while drawing borders by grouping dots, a more flexible region to acquire shape information and a region for requiring specific mathematical functions.

Shape acquisition is flexible. One can combine 4 dots in all shapes, although they will probably be combined as a square most of the time. Continuity, alignment and outline are key features.

If we should get back to developmental process, in the early years of life, the infant has to work with the diffused shapes and shadows and slowly disparity and motion sensitivity become available [28]. The blind infant probably also develops a haptic 6DF vantage point. The continuum of bottom-up processes are linked to a top-down input between flexible shape areas [49]. The drawing development calls for the calculation of border and more flexible areas to work on shape information, and regions with ecological shapes that cut across senses.

There is a great accumulation of cross-modal functional neuroimaging studies on human tactile perception. Along with somatosensory areas, motor and more surprisingly visual areas are involved in many tactile processes. In this section we will review some of them, likewise studies with the blind will be discussed in latter sections.

2.3.1 Somatosensory areas

Posterior part of postcentral gyrus is known to activate during PET [50, 51] and fMRI studies [52, 53] in humans during haptic discriminations of 3D shapes. The effect is hemispheric (contralateral to the active hand) [51, 52] or bilateral [50, 53].

Later studies point out to a hierarchy of form information processing within the somatosensory cortex [51]:

1. Anterior postcentral gyrus (Brodmann 3b and 1) activated non-specifically during numerous tactile tasks including discrimination between 3D shapes, discrimination of sphere, curvature, roughness, velocity of skin stroking etc [51].

2. Postcentral sulcus (Brodmann 2) (along with surrounding postcentral gyrus) was activated during 3-D shape and curvature discrimination [50, 51].

3. The anterior part of intraparietal sulcus (IPA) was active during shape discrimination only [51, 54].

4. The anterior part of the supramarginal gyrus (ASM) was also active during shape discrimination only [51].

Thus it was suggested that areas 3b and 1 are at the bottom of the hierarchy which initially processes somatosensory input regardless of the task. Area 2 is in the intermediate level for processing both curvature and complex shapes [55] and the IPA and ASM (posterior parietal areas) at the top of the hierarchy responsible for the complex shape discrimination. It was noted that for higher accuracy, more involvement of IPA and ASM was observed, and more demanding tasks called for extra posterior parietal contributions [51, 53, 54].

2.3.2 Motor areas

Primary motor cortex (PMC) [51, 56], dorsal premotor cortex (PMd) [51, 56, 57], ventral premotor cortex (PMv) [57, 58], and supplementary motor area (SMA) [51, 56, 58], are known to be involved during tactile form discrimination even in the absence of a physical movement. It is suggested that these activations are due to the higher order decision-making processes. They could be due to automatic planning of manual interaction with the objects during the experiment. Lateral premotor cortex was activated in an experiment which included a control condition that lacked the tactile exploration but required a verbal output at a similar rate.

Mental rotation of tactile objects activated PMd and PMv along with the dorsal visual stream whereas form discrimination activated PMv bilaterally [57]. Dorsal premotor cortex and dorsal visual stream are strongly interconnected [59]. Form discrimination on the other hand activated ventral premotor cortex along with the ventral visual stream. These networks seem to be working in a visio-motor network projecting dorsally or ventrally.

2.3.3 Visual areas

Functional neuroimaging studies revealed the involvement of visual areas in haptic 3D object identification: striate and extrastriate cortex [60], lateral occipital complex (LOC) which is the occipito-temporal area in the ventral pathway [61] and a specific subregion of LOC [62, 63, 64] are known to be activated during tactile tasks.

In order to address the generality of visual cortical recruitment during haptic exploration of forms and to explore the effects of perception versus mental spatial manipulation, Prather et al. [65] presented their sighted subjects with finger-sized alphanumeric forms. The orientations they used included a mirror image versus mental rotation configuration where subjects had to rotate the stimuli before reporting their answer, a gap configuration where subjects needed to detect a gap and a form configuration where subjects were asked to distinguish between two alphanumeric forms. Additionally an orientation condition was tested where the subjects needed to report the angular orientation of a bar.

Mental rotation condition evoked activity in the left postcentral sulcus (IPCS) contrasted with all other configurations [65]. Posterior parietal cortex is known to be activated during mental rotation of tactile stimuli [66] and visual stimuli [67].

When contrasted with either orientation or gap condition, mental rotation evoked bilateral activity in parieto-occipital cortex (POC) extending superiorly into superior parietal cortex. SPC and POC are located postero-superior to the parietal foci of

IPA and ASM which are theorized to be the top hierarchical loci of advanced 3D shape discrimination. They lie at the dorsal visual pathway which is responsible for visio-spatial processing.

Relative to the orientation condition, form condition activated LOC contralateral to the hand used. LOC is, as discussed before; the object selective region located in the ventral visual pathway.

In summary, tactile form discrimination evoked activity in ventral visual pathway while spatial manipulation of visual forms evoked activity in dorsal visual pathways. This is consistent with the visual mental rotation findings [68] and general information flow of visual information at what and where level [69].

These findings are consistent with transcranial magnetic stimulation (TMS) studies where the transcranial magnetic stimulation over parieto-occipital cortex disrupted the tactile discrimination of grating orientation task (GOT) [70]. In related fMRI [58] and PET [65] studies, there were bilateral activity in LOC (even though the stimuli was explored using the right hand only). LOC activity was not seen in the gap detection task.

Gap tasks are microspatial and calls for analysis in small scale features while the form tasks are needed in large-scale feature exploration level and are macrospatial. Since vision is thought to be superior for analysing global features [71], macrospatial tasks are associated with visual pathways [72] LOC of the ventral visual pathway has higher activity with the macrospatial gap task [58, 65] and supports these findings.

3. METHODOLOGY

3.1 Participants

Twelve sighted, 12 congenitally blind subjects volunteered to participate. Their signed consent was acquired. Mean age for both groups was approximately 24, (sighted: 22-28, blind: 19-34). The sighted were blindfolded through the experiment. Both groups were naive for the study. All participants were right handed (tested by Edinburgh Handedness Inventory [73]) and gender was balanced among groups. Blind subjects were asked about the extent and cause of blindness. All the participants were educated to some level, and all the blind subjects were able to read and write Braille alphabet.

Table 3.1
List of sighted participants

No	Age	G	Hand	Cond
ss1	25	F	R	Sighted
ss2	22	F	R	Sighted
ss8	26	F	R	Sighted
ss11	25	F	R	Sighted
ss14	22	F	R	Sighted
ss19	22	F	R	Sighted
ss5	26	M	R	Sighted
ss6	29	M	R	Sighted
ss7	26	M	R	Sighted
ss12	28	M	R	Sighted
ss17	27	M	R	Sighted
ss21	20	M	R	Sighted
Mean Age = 24.8				

Table 3.2
List of blind participants

No	Age	G	Hand	Cond
sb2	19	F	R	Blind
sb5	19	F	R	Blind
sb6	19	F	R	Blind
sb13	33	F	R	Blind
sb14	21	F	R	Blind
sb15	19	F	R	Blind
sb4	33	M	R	Blind
sb7	25	M	R	Blind
sb8	25	M	R	Blind
sb9	23	M	R	Blind
sb11	34	M	R	Blind
sb16	21	M	R	Blind
Mean Age = 24.3				

Table 3.3
Cause of blindness

No	Onset	Cause	Light Percetion
sb2	Congenital	Cancer - Tumor in the eyes	Little light perception
sb5	Congenital	Genetic Disorder	No light perception
sb6	Congenital	Genetic Disorder	No light perception
sb13	Congenital	Retinitis Pigmentosa	No light perception
sb14	Congenital	Waardenburg syndrome	No light perception
sb15	Congenital	Genetic Disorder	Little light perception
sb4	Congenital	Genetic Disorder	No light perception
sb7	Congenital	Retinal Disorder	No light perception
sb8	Congenital	Cancer - Tumor in the eyes	No light perception
sb9	Congenital	Retinitis Pigmentosa	Little light perception
sb11	Congenital	Retinal Disorder	No light perception
sb16	Congenital	Genetic Disorder	No light perception

3.2 Materials

3.2.1 Objects

Two tactile L - shaped objects (3 cm short edge, 5 cm long edge, 1 cm depth) were glued on card boards (50x7cm) as pairs. they were prepared as rotated on the picture plane at eight angles (0° , -45° , 45° , -90° , 90° , -135° , 135° , 180°) so we acquired five absolute angular differences (0° , 45° , 90° , 135° , 180°). Rotations were made clockwise, counter-clockwise, right hand object clockwise / left hand object counter-clockwise and vice versa. The pairs were either same or different – different meaning mirror as known to the experimenter.

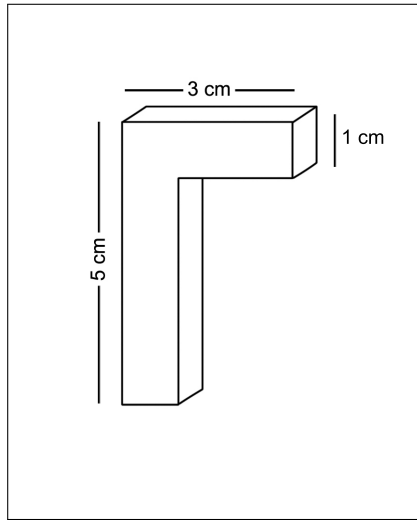

Figure 3.1 Dimensions of the objects

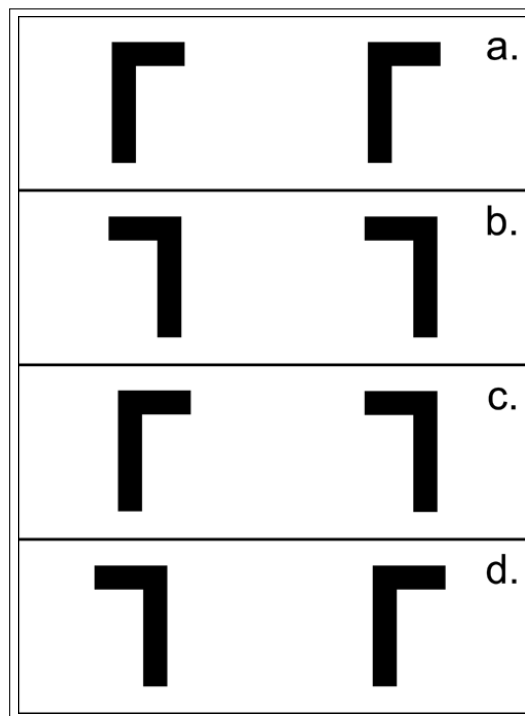

Figure 3.2 Stimulus types. a and b include the 'same' stimuli, c and d include the 'different' stimuli (mirror image).

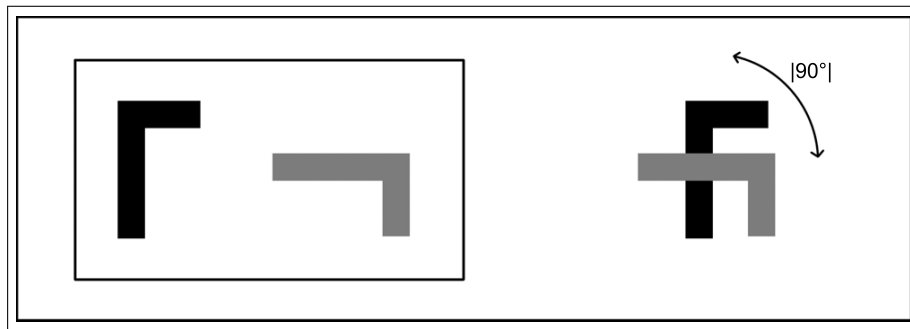

Figure 3.3 Stimuli. Since there are no distinctive features of shapes to differentiate, subjects rotated either object on the picture plane to acquire a match. The absolute value of the angular difference was probably mentalized.

3.2.2 Tactile platform

A passive tactile method was developed. Subjects' hands rested on a 52x25 cm platform, palms facing down. The objects were lifted with a lever. This way, hand position stayed as steady as possible during the experiment.



Figure 3.4 Experimental setup

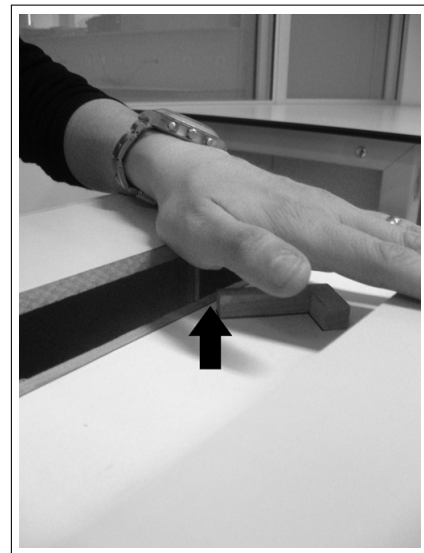

Figure 3.5 The lever mechanism

3.3 Procedure

256 pairs were presented to subjects in 16 sets, each set consisted of 16 stimuli. The correct answer, angle and the direction of rotation were assigned randomly. Each stimulus was labelled with a number and it was presented to each participant in the same order. The pairs were presented after describing the task and sufficient amount of training. We asked the participants to visit us twice for a training session and an experiment session. We designed a standard training method which could be understood by both the blind and the sighted. After the first encounter with the objects, we asked the subjects to explain us the shape information they acquired. Since palms are not generally used to extract shape information and the topography of the palm can be confusing (which was generally the case for participants) they were allowed to explore the objects using their fingers during the learning session. The definition mirror is ambiguous to the blind, so to indicate one pair is same or different, we asked subjects to try to put two objects on top of each other and see if they acquire a match. The first pairs we have given the subjects had stimuli at 0° , the same and the different. When the orientation got in the way, we told the subjects that they could change the orientation. After the shape and orientation information are gathered, the participants had to rotate one object to align with the other. So the rotation was implied but not directly told. Palms were used then through the training and the experiment. During the training session, feedback was given to participants and they were asked to explain the method they used. At the experiment session we asked the subjects to explore the objects tactually and decide if the pairs were same or different – different meaning mirror as known to the experimenter. No feedback was given at this point. The response time and the accuracy were recorded.

3.4 Analysis

Accuracies and response times were recorded and analysed for each group of subjects. Incorrect responses were recorded but not included in the analysis investigating

the effect of mental rotation.

Accuracy was calculated by taking the percentage of correct answers.

Three-way ANOVA and regression tests were used to study the differences in the factors and to explore correlations. In each analysis, the factors were the subject group (blind \ sighted), the stimulus (same \ different) and the angular difference ($0^\circ, 45^\circ, 90^\circ, 135^\circ, 180^\circ$)

In our previous studies, we found out that when all stimuli were included, the response time was not significantly correlated with the angular orientation. However, the response time for only the same stimuli increased linearly with angular orientation [74]. Therefore, here we took the stimuli separately into consideration and checked both same and different conditions.

4. RESULTS

We assumed the subjects rotated one of the objects to match the other one which is being simultaneously explored. We assumed that the subjects rotated to the shortest direction to get a match, regardless of the rotation side and direction. Since we did not give any prior cues, the angular discrepancy of -90° may be treated as 90° . So we used the absolute values of angular differences. Hence the angle factor has 5 variables; $0^\circ, 45^\circ, 90^\circ, 135^\circ, 180^\circ$.

4.1 Accuracy

A three-way ANOVA was performed to study the effects of angle ($0^\circ, 45^\circ, 90^\circ, 135^\circ, 180^\circ$), the stimuli type (Same/Different), and subject group (Sighted/ Blind)

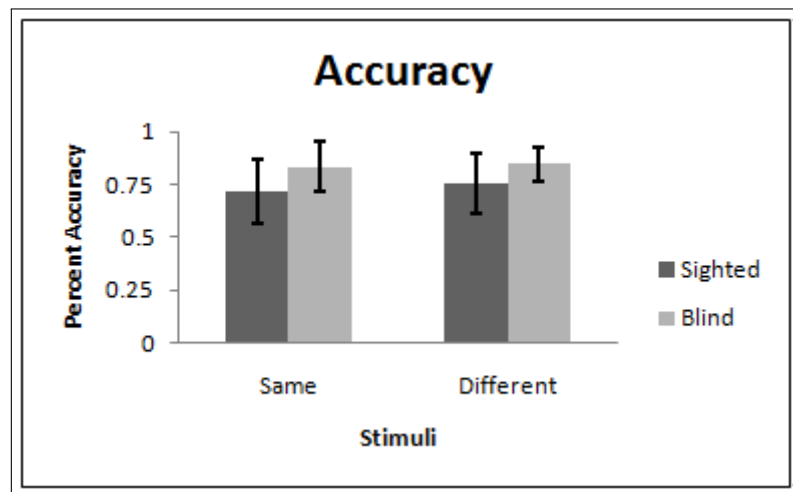

Figure 4.1 Percent accuracy in sighted and blind subjects

The subject group had a significant main effect ($F(1,460)=41.3, p<0.001$). Blind participants scored significantly higher (mean=84.1) than the sighted participants (mean=74.1) No significant effect of orientation or stimulus type was found. There was a significant two-way interaction between angle and stimulus type ($F(4,460)=3.6, p=0.007$). There was no significant effect for other two way interactions, and the 3-

way interaction of angle, stimulus type and subject group was not significant. When all the stimuli (same and different) were included, accuracy was negatively correlated with angular orientation for the blind ($r=-0.981$, $p=0.003$), while it did not seem to be correlated with angular orientation for the sighted participants ($r=-0.457$, $p=0.439$)

Table 4.1
Correlation of accuracies for sighted and blind subjects.

Subject	r	p
Sighted	-0.457	0.439
Blind	-0.98	0.003

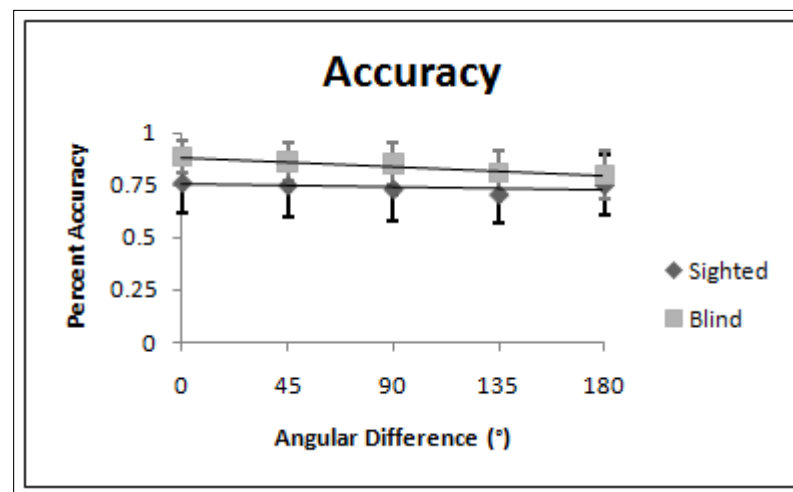

Figure 4.2 Linear relationship between angular difference and percent accuracy for sighted and blind subjects

4.2 Response time

A three-way ANOVA was performed to study the effects of angle ($0^\circ, 45^\circ, 90^\circ, 135^\circ, 180^\circ$), stimulus type (same/different), and the subject Group (Sighted/Blind). Test for the main effects of angle ($F(4,460)=34.5$, $p=0.038$), stimulus type ($F(1,460)=88$, $p=0.011$) and subject group ($F(1,460)=272.5$, $p<0.0001$) were all significant. No effects of any two-way or three-way interactions were found.

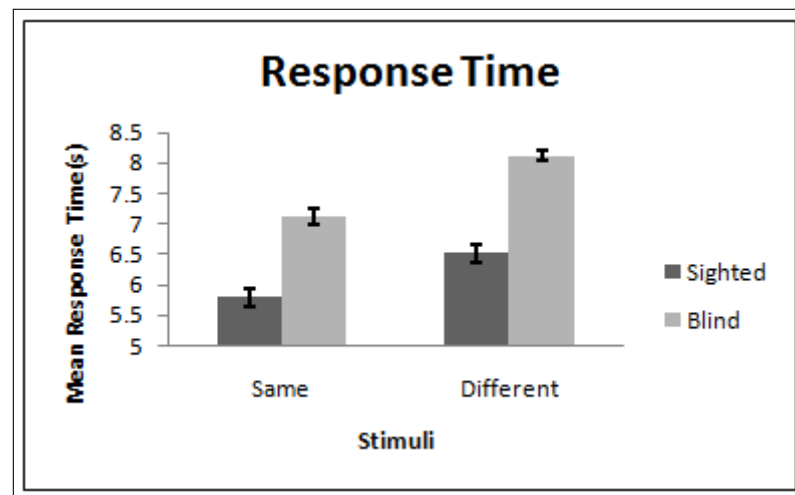

Figure 4.3 Mean response times of the same and the different stimuli for blind and sighted subjects

4.3 Mental rotation test

For all stimuli included, the response time was significantly correlated with the angular orientation (sighted: $r=0.988$, $p=0.002$; blind: $r=0.948$, $p=0.014$). The correlation was seen again for both sighted and blind group for the same stimuli (sighted: $r=0.935$, $p=0.002$; blind: $r=0.925$, $p=0.025$). However it was not the case for different pairs in blind subjects. The sighted participants' data yielded a significant correlation with angular orientation for different pairs. ($r=0.989$, $p=0.001$)

Table 4.2

Correlation of response times versus angles for sighted and blind subjects; all stimulus included.

Subject	R	P
Sighted	0.988	0.002
Blind	0.948	0.014

Table 4.3

Correlation of response times versus angles for sighted and blind subjects, only the same stimuli are included.

Subject	R	P
Sighted	0.935	0.020
Blind	0.925	0.025

Table 4.4

Correlation of response times versus angles for sighted and blind subjects, only the different stimuli are included.

Subject	R	P
Sighted	0.99	0.001
Blind	<i>0.509</i>	<i>0.381</i>

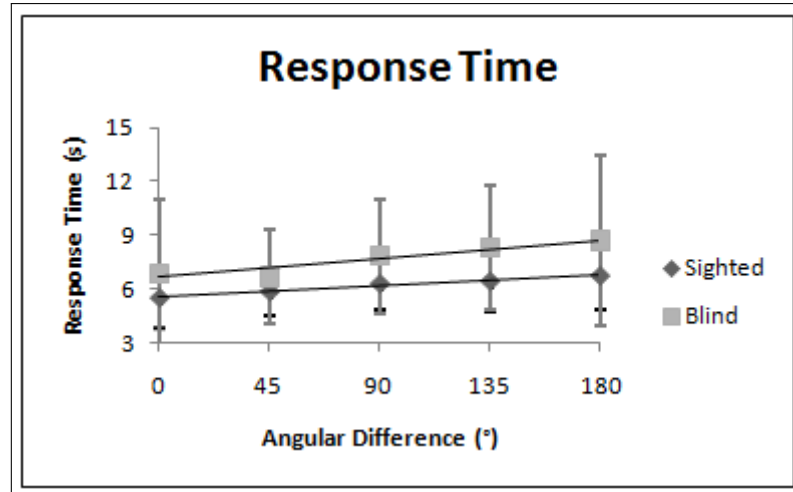

Figure 4.4 Linear relationship between angular difference and mean response times for all stimuli (same and different).

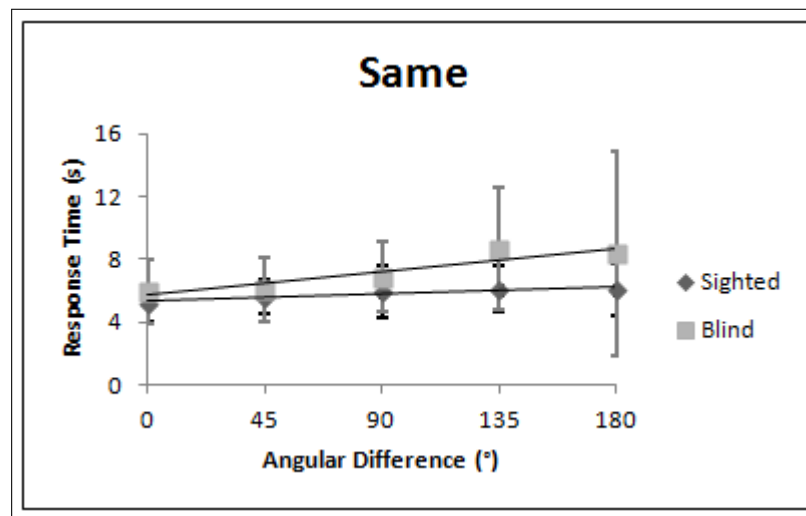

Figure 4.5 Linear relationship between angular difference and mean response times of only the same stimuli.

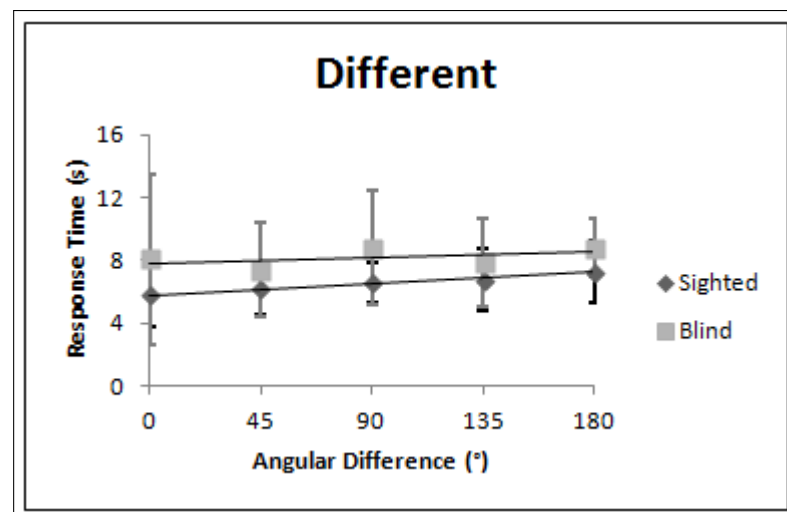

Figure 4.6 Linear relationship between angular difference and mean response times of the different stimuli.

4.3.1 Slopes and intercepts

The slopes and intercepts of correct response times versus angles can be used to establish a process model and to explore the mental rotation effect in a more detailed fashion.

Table 4.5

Linear relationship formulas of sighted subjects for three stimulus types.

Stimuli	Formula	R^2
All	$y = 0.0071x + 5.525$	$R^2 = 0.976$
Same	$y = 0.0053x + 5.324$	$R^2 = 0.874$
Different	$y = 0.0079x + 5.798$	$R^2 = 0.979$

Table 4.6

Linear relationship formulas of blind subjects for three stimulus types.

Stimuli	Formula	R^2
All	$y = 0.0117x + 6.631$	$R^2 = 0.898$
Same	$y = 0.0166x + 5.693$	$R^2 = 0.855$
Different	$y = 0.0044x + 7.794$	$R^2 = 0.258$

It should be taken into consideration that slopes were calculated as such that the value of the slopes (Tables 4.5 and 4.6) correspond to the inverse speed. For all stimuli included, slopes and intercepts of the blind were found to be higher than the sighted.

For the sighted group, slopes and the intercepts of different stimuli was higher than the same stimuli whereas for the blind group, slope of the same stimuli was higher while the intercept of the different stimuli was the highest.

5. DISCUSSION

This study compares sighted and blind subjects in a tactile mental rotation task. The main question was whether an analogue process, i.e. mental rotation depends on visual imagery or not. The results show us that it does not because congenital blind subjects were able to perform the task similar to the sighted subjects.

Analyses of variance and correlation analysis were performed to explore differences between the subjects and the mental rotation effect. We explored the conditions when all stimuli included, and when the same and different stimuli were separately analysed.

Linear relationship between angular difference and response time is an evidence for the mental rotation effect. Higher angular differences take longer time to rotate and match. Therefore this task is highly analogue almost like images are literally rotated in the brain. This was put to question by using congenital blind subjects who never encountered any visual inputs. There were significant differences between response times and accuracies between the groups. However, the ability to succeed in the task for both groups suggests that the mental rotation task may be calling for the same neural substrates.

5.1 Accuracy

Blind subjects were significantly more accurate than the sighted subjects. The higher accuracy of the blind can be explained by the familiarity of the task to blind subjects.

In a series of experiments Heller et al. found that visually impaired people performed better than the blindfolded in picture perception, perception of perspective and depth, and in tasks requiring perceptual selectivity.

Especially subjects with very low vision performed the fastest and the most accurate under likewise experimental conditions. He later on tested for gaze and light effects. Results indicated that higher performance cannot be explained only by gaze and lack of blindfolds [32, 34, 37].

Sighted subjects are relatively unfamiliar with haptic perception. Their less accurate exploration may be reflecting their uncertainty and unfamiliarity with the task. In daily life, sighted learn to control haptic sense with a simultaneous visual guide. In order to eliminate that effect in our experiment, we blindfolded the sighted subjects prior to learning so the visual system was not actually involved during the process. Therefore the higher accuracy of the blind may be due to the effect of increased haptic skill, practice and familiarity due to the past non-visual experience.

Blind subjects' accuracy was significantly negatively correlated with angular orientation. That means, for the blind subjects, as the angular difference between two objects increased, the accuracy decreased. It was harder to answer correctly for larger angular differences. Accuracy was not correlated with angular orientation for sighted subjects.

5.2 Response time

Blind subjects were significantly slower than the sighted subjects who completed the task. The sighted subjects' translation of the tactile input to a visual code might be the reason of speed difference. It is consistent with the literature that visual imagery may make the recognition and rotation faster [16, 19]. Even with their eyes closed, sighted blindfolded subjects are known to use their visual cortical areas during tactile recognition tasks [16, 70].

For sighted subjects, correlation analyses of response time against angular difference increase significantly with angular difference. This is the case for all correct stimuli included, as well as separately for the same and different stimuli.

However this effect was not identical for the blind subjects. For all stimuli included and for the same stimuli, response time linearly increased with the angular difference. Different/mirror stimuli did not linearly change with the angular difference. This may be due to the certainty of the match case whereas for different, there is no match so the blind subjects might be checking for all possible rotations between objects.

5.3 Mental Rotation

The linear relationship between the response time and the angular difference between the objects shows the effect of mental rotation [5, 6, 12]. Both of our groups show linearity. This is consistent with the literature [16, 17, 19].

5.3.1 Establishing a process model

The original mental rotation process model was such that when a stimulus was presented, a template of that exact shape was formed, then the upcoming stimulus was compared to that first one. Angle information was extracted and the comparing was done by rotation. If no match found, second stimulus was found to be the mirror image of the first one [5, 6]. Note that in our task, two shapes being compared were simultaneously present. Therefore, the subjects as confirmed with the introspective reports:

i) Encountered with the objects and felt them, and decided for a rotation hand and direction,

ii) Subsequently the rotation process occurred.

iii) Vocal response as 'same' if they got a match by rotating the objects, and as 'different' if no match was acquired.

Therefore the processes were designed as, the decision box, rotation box and the output box.

It may be plausible to assign intercepts to the decision box and the output box while the slopes may be assigned to give information on the rotation process. Consider that the slope information is inverted due to the calculations. Hence higher numerical value of the slope means slower rotation speed. As for the intercepts; higher intercept value means longer processing time. Furthermore, we can safely assume that the output box was similar in both groups.

Comparison of blind and sighted:

For all stimuli included, slopes and the intercepts of the blind were higher than the sighted. Therefore, both decision and rotation processes occur slower and take longer time for the blind. We do not know the exact properties of the decision box. Our subjects claimed being able to sense the three edges of the shapes clearly, and they had to group the three dots to acquire a continuous shape information each time. By the gestalt of the dots, shape and rotation properties are identical. The shape information does not dynamically change in our task nonetheless. The introspective reports show that it is rather the handedness and rotation properties more than just finding the shape. The blind may be sequentially processing the hands during the decision box.

Within group comparisons:

For the sighted group, slopes and intercepts of different stimuli was higher than the same stimuli. In sighted subjects, both rotation and decision seem to take more time for the different stimuli than the same.

For the blind group, slope of the same stimuli is higher while the intercept of the different stimuli is the highest. Therefore, in blind subjects, decision box seem to take more time for different pairs than for the same, while rotation of the different

stimuli seemed to occur faster. Recall that the slope was so small in different compared to same, the mental rotation effect was lost. The different stimuli may be calling for a control mechanism, the rotation may be repeated a couple of times as well as the coding of the stimuli. Because for the different stimuli, the experimental demand of matching the shapes is not met.

5.4 Functional imaging studies

Both of our participant groups used one sense: touch. However, sighted blindfolded participants claimed using a visual extraction of the shape and actually seeing the object being rotated whereas congenitally blind told us they felt like almost rotating the object by their hands. We made sure hands, head or arms which can work as a cue were stable during the experiment. So the blind subjects imagined haptic movement whereas the sighted imagined visible movement. Despite the differences, they were both capable of processing geometrical structure of objects. It is perhaps not surprising that higher order processing of objects appear much the same way independent of the input modality. Touch and vision are the only two sensory systems that can extract 3D shape information. Both are primarily used for distinctive feature finding like weight information is specific to touch, while color, shade or texture are to vision. When it comes to spatial recognition, different input modality may lead to same process.

Viewing angles of objects and space are basically different in two modalities, but likewise viewing angle conditions can be created experimentally. Haptic recognition of 3D objects that are fixed to a surface is found to be better in experimental sessions, rather than when the object configuration is changed. This calls for a somehow similar representation for two modalities.

5.4.1 A verbal or semantic processing

The studies with infants and monkeys are contradictory to this model. It could be theorized that the haptic input activates an abstract and mainly semantic or symbolic representation of the stimulus which can be moved in both haptic and visual representation afterwards. Studies with infants and chimpanzees who have limited capacity of semantic or symbolic representation shows that the bimodal effect in the sighted does not originate from an abstract representation [75]. Moreover one would expect subjects to obtain relatively invariant reaction times in semantic processing. Along with mental rotation studies, we observe conditional changes in the response time.

5.4.2 A single representation for both modalities

Cross-modal priming studies between vision and haptics suggest a single multi-modal representation. In a cross-modal priming experiment, subjects are first exposed to the stimuli in one modality, they are then asked to recognize or operate on the stimuli in the other modality during the experiment. It is known that when vision and haptics are primed together, visual representation of an object can be activated by a haptic presentation and vice versa [76, 77, 78].

Imaging studies show that haptic identification of objects stimulates activation in primarily extrastriate areas in the occipital cortex (V2,V3,V4) [62, 63, 64]. Moreover, when TMS was applied to the occipital cortex of subjects during haptic identification of a grating placed on their finger, it changed the recognition ability significantly when applied contralaterally [70].

Lateral Occipital Complex (LOC) is a region that is activated during selective processing of visual objects [61, 79] and at visual priming studies with common [80], and with novel objects [81].

More recent studies show bimodal function of LOC, a significant haptic to visual priming effect [62, 63]. During the haptic to visual priming, LOC of sighted subjects when objects were explored either tactually or visually; but not when they were asked to imagine the objects [62]. This shows that the effect is not due to the visual imagery. LOC did not seem to be active during a priming study where the sighted subjects were first encountered with the objects either tactually or visually, and then were asked to respond to an audio cue [63]. This shows that the activity of LOC is not multimodal but bimodal to touch and vision; hence, is about the 3D structure information. A specific crossmodal analysis confirmed that priming effect of LOC is equivalent whether the first encounter with the object is haptic or visual [64]. Participants were viewing the previously tactually or visually explored stimuli at all times so priming was either haptic to visual or visual to visual. The authors discussed that the visual imagery during tactile scanning could not be the explanation of LOC activation, because the stimuli were either directly viewed or only haptically explored at a time [64].

There are also behavioural experiments where crossmodal priming effects of haptics and vision are explored on sighted subjects [76, 77, 78]. The within modal priming effect was as much as the cross modal priming. This also shows that no previous visual input is needed.

A patient with bilateral lesions in LOC was not able to recognize novel objects based on contour information, either by vision or by touch [82]. Literature holds a report of a subject with prosopagnosia who could not recognize face either visually as expected; or by touch [83].

5.4.3 Blindness unmasking the brain's naturally suppressed abilities

Braille reading and similar tactile tasks activate occipital cortex of early-blind subjects primarily in V1 and V3, while they seem to suppress these regions in sighted [84, 85]. Event related potentials (ERPs) also suggest activation of visual areas, both striate and extrastriate, in early blind [86] along with similar fMRI studies [87, 88].

Braille is a specific example because of the highly cognitive and linguistic load of processing required, but other tactile tasks of similar nature also show the same effect. rTMS applied to occipital cortex seemed to disrupt Braille reading. Subjects knew that they were contacting the letter, meaning that the sensory experience was intact, but they could not identify the letters [48]. Unlikely, occipital stimulation had no effect in tactile tasks in sighted subjects [89].

Single-pulse TMS with predefined interstimulus intervals can give out information on timing off the sequential processing. With intervals of 20-40 msec to left somatosensory cortex, transcranial magnetic stimulation disrupts the ability to sense the letters in blind subjects while TMS to striate cortex with 50-80 interstimulus intervals impaired the ability to discriminate the letters, leaving the sense of touch intact [90].

Braille studies however may be misleading due to the nature of task. Sighted subjects learn Braille by visual instructions and are generally are not as successful at it as the blind. It raises the theoretical question of whether the modifications of cortical projections in blind are due to long-term Braille reading experience, or is blindness a behavioural advantage in acquisition of Braille reading and skills of similar nature.

Gratings orientation task (GOT) may be useful to answer this question. Requiring precise and detailed tactile feature discrimination, GOT thresholds are widely studied to measure human ability to process spatial information. [91]. Subjects are asked to make judgements about groove widths of hemispheric plastic domes. Like Braille, blind subjects are superior to sighted in GOT especially when using the preferred Braille finger [92]. Apart from the higher tactile sensitivity to local features, it is suggested to be the result of increased occipital activity during the task [93]. In addition, GOT is known to increase metabolic activity in parieto-occipital areas during tactile tasks shown by PET [94] and occipital TMS interferes with GOT performance [70, 94].

A particular early-blind patient who had bilateral occipital strokes is known to

show inability to read Braille although she did well in other sensory tests. She also had trouble reading embossed Roman letters and had difficulty with GOT [95].

The role of occipital cortex in tactile tasks have long been questioned and evidence shows they are far from being coincidental, though it can be suggested that the effect is due to visual imagery. Visual imagery is the endogenous activity of visual pathways when the actual visual input is not available [96]. There is always a possibility of using feed-forward visual imagery for sighted subjects during haptic tasks. Although studies with early and congenitally blind show data that it is not the case, blind as well as sighted tend to tell the experimenter about imagining a tactile sense which could be thought as the mind's finger more than the mind's eye.

An auditory cue-task which was originally used to test sighted subjects for imagery effect was used in blind and sighted subject groups. Groups were assigned to receive either rTMS or sham-TMS on touch and vision related brain areas. Reaction times for the blind got significantly higher after sensiomotor rather than occipital rTMS and sighted had longer reaction time after the occipital rather than sensiomotor rTMS. Error rates did not seem to change. Blind subjects claimed imagining themselves feeling the letter on their finger during the auditory cue about the letter, like sighted subjects who claimed seeing the letters [95].

There may be thalamo-cortical pathways to both sensory and visual cortex which are post-natally masked or even degenerated in the sighted due to the predominant evolutionary role of visual system. On the other hand there may be direct cortico-cortical connections in between sensory and visual areas which normally behave unimodal but are facilitated when needed, for instance in the deprivation of sight.

Blindness may be unmasking relatively ancient abilities of occipital cortex which include processing on the non-visual information. Otherwise blind and sighted may be coding a common representation on 3-D space input.

What happens if we deprive the sighted of vision? May we reveal the masking?

Normal sighted individuals were blindfolded with special light-proof folds for 5 days and their occipital cortex was investigated for potential new functional connectivity using functional MRI and TMS techniques [97]. The experiment group was blindfolded at all times while the control was blindfolded during intensive Braille training and during test sessions. Blindfolded group was significantly better at learning in favor of the behavioural advantage of blindness at tactile tasks theory. Data was collected at the beginning (baseline activity), at the last day of the experiment and another measurement had been taken at day 6 to check for the after effects. The serial fMRI show increasing action of striate and extrastriate cortex during tactile and auditory cues for blindfolded. On the fifth day of the experiment additional increasing activity was noted in the occipital cortex which was then ceased on the 6th day. Control subjects' data remained the same all through the experiment. On the 5th day of deprivation TMS seemed to disrupt the Braille recognition task which required subjects to complete a series of same/different tasks. Five days seem to unmask different roles of occipital cortex while it seems to disappear within 12-24 hours after removing the blindfolds.

Pascual-Leone later discussed that new cortical connections may be established. This leads us to a metamodal visual cortex rather than unimodal or bimodal activity [97].

Early blind do show occipital activation [48], and occipital cortex involvement is known to contribute to tactile acuity [93]. But as the group discussed later on, the experiment with sighted subjects cannot be a substitute for knowing what actually is going on with the blind brain.

5.5 Limitations of the study

We tried to keep some variables balanced and under control like handedness, gender, age and onset of blindness. The experiment was done in different places for easy access of all participants yet the conditions were similar. All sites were quiet, well ventilated and sitting positions of the subjects were similar. Yet some variables

were uncontrolled like the current mood of the participant, their characteristic qualities (eagerness, competitiveness, etc.) or the size of their hands. These factors we believe are not strongly affecting our results.

We tried to keep fatigue levels low and the attention of the subject intact by letting the subjects call for their own breaks.

Our blind participants showed high variability. The age interval of blind subjects was higher than the sighted. Their lifestyles and educational levels were carefully limited.

Spatial ability of the sighted subjects was not tested, but their jobs and professions were noted down. A spatial ability test may be useful in understanding what participants can do and how it can affect their results in mental rotation.

Time keeping was done by an experimenter manually. A more automated system may be more precise.

6. CONCLUSION

Mental rotation is the process of rotating an objects' mental representation. It may be tested in a task in which two stimuli are compared to be identical or mirror images. When the task is done visually, it was seen that the reaction time increases linearly with the angular difference between the presented stimuli.

In this study, it was hypothesized that the exploration of tactile stimuli would yield similar results in the sighted as well as the blind participants. In many studies the literature holds, the question whether the blind are using the same mental ways to complete this task remained controversial.

Using our set up we observed the effect of lack of visual input to tactile object recognition. Our results show that the blind as well as the sighted succeeded in the mental rotation task without any prior visual cues. By using this significant finding we suggest that the brain can work on the 3D space information regardless of its modality. This explanation was supported with findings in the literature.

We have observed different correlation patterns in same and different stimuli pairs.

We discussed the results along with previous neuropsychological and functional imaging studies.

In brief, we found that the blind can do mental rotation much like the sighted. By this finding we suggested a common representation may be used during 3D shape discrimination tasks in both existence and absence of visual input to the brain. We analysed same and different stimuli pairs separately. We found out a difference may be present in response patterns. This was to our knowledge, not mentioned in the literature. We dissected the process into boxes following up the literature. We suggested

there may be slight adjustments in the working model due to subject group and the stimulus types.

6.1 Future Work

This study is consistent with the literature. It can be further developed by constructing new mathematical models of mental processing. The stages of recognition and rotation can be separated and observed by more elaborate experimental design.

The difference we found for the 'same' and the 'different' stimuli pairs can be further explored by giving the subjects prior cues and limitations as well as by using other psychological testing methods.

This work may be useful to understand the multimodal and specific mechanisms in the brain and especially for understanding blindness. This theoretical work may later be used to develop artificial intelligence technologies, educational tools and specific equipment for the blind.

REFERENCES

1. Kosslyn, S. M., and O. Koenig, eds., *Wet Mind The New Cognitive Neuroscience*, Theime, 1992.
2. Sacks, O., ed., *The Man Who Mistook His Wife for a Hat, and Other Clinical Tales*, Summit Books, 1985.
3. Pinker, S., "Visual cognition: An introduction," *Perception*, Vol. 18, pp. 1–63, December 1984.
4. Marr, D., and H. K. Nishihara, "Representation and recognition of the spatial organization of three dimensional shapes," *Proceedings Royal Society of London B*, Vol. 200, pp. 269–294, February 1978.
5. Cooper, L. A., and R. N. Shepard, "Chronometric studies of the rotation of mental images. visual information processing," *Visual Information Processing*, Vol. 75, p. 176, 1973.
6. Shepard, R. N., and J. Metzler, "Mental rotation of three-dimensional objects," *Science*, Vol. 171, pp. 701–703, February 1971.
7. Cooper, L. A., "Mental rotation of random two-dimensional shapes," . *Cognitive Psychology* 7, Vol. 7, pp. 20–43, January 1975.
8. Corballis, M. C., and RMcLaren, "Winding one's ps and qs: Mental rotation and mirror image discrimination," *Journal of Experimental Psychology: Human Perception and Performance*, Vol. 10, pp. 318–327, April 1984.
9. White, M. J., "Naming and categorization of tilted alphanumeric characters do not require mental rotation," *Bulletin of the Psychonomic Society*, Vol. 15, pp. 153–156, March 1980.
10. Garvin, E. A., and J. M. Vanderplas, "The association value of random shapes," *Journal of Experimental Psychology*, Vol. 57, pp. 147–154, March 1959.
11. Corballis, M. C., and I. L. Belae, "Bilateral symmetry and behaviour," *Psychological Review*, Vol. 77, pp. 451–464, September 1970.

12. Cooper, L. A., and R. N. Shepard, "Chronometric studies of the rotation of mental images. visual information processing," *Visual Information Processing*, Vol. 75, p. 176, 1973.
13. Corballis, M. C., and R. McLaren, "Winding one's ps and qs: Mental rotation and mirror image discrimination," *Journal of Experimental Psychology: Human Perception and Performance*, Vol. 10, pp. 318–327, April 1984.
14. Parsons, L. M., "Imagined spatial transformations of ones hands and feet," *Cognitive Psychology*, Vol. 19, pp. 178–241, April 1987.
15. Koriat, A., and J. Norman, "What is rotated in mental rotation?," *Journal of Experimental Psychology: Learning, Memory and Cognition*, Vol. 10, pp. 421–434, July 1984.
16. Prather, S. C., and K. Sathian, "Mental rotation of tactile stimuli," *Cognitive Brain Research*, Vol. 14, pp. 91–98, June 2002.
17. Carpenter, P. A., and P. Eisenberg, "Mental rotation and the frame of reference in blind and sighted individuals," *Perception & Psychophysics*, Vol. 23, pp. 117–124, November 1978.
18. Koriat, A., and J. Norman, "Mental rotation and visual familiarity.," *Perception & Psychophysics*, Vol. 37, no. 5, pp. 429–439, 1985.
19. Marmor, G. S., and L. A. Zaback, "Mental rotation by the blind: does mental rotation depend on visual imagery?," *Journal of Experimental Psychology: Human Perception and Performance*, Vol. 2, pp. 515–521, November 1976.
20. Dellantonio, A., and F. Spagnolo, "Mental rotation of tactual stimuli," *Acta Psychologica*, Vol. 73, pp. 245–257, April 1989.
21. Cohen, N. J., and L. R. Squire, "Preserved learning and retention of pattern analyzing skill in amnesia: Dissociation of knowing how and knowing that," *Science*, Vol. 210, pp. 207–210, October 1980.
22. Sternberg, S., "The discovery of processing stages: Extensions of donders' method," *Acta Psychologica*, Vol. 30, pp. 276–315, 1969.

23. Eriksen, C. W., and D. W. Schultz, "Information processing in visual search: A continuous flow conception and experimental results," *Perception & Psychophysics*, Vol. 25, no. 4, pp. 249–263, 1979.
24. Miller, J. O., "Discrete versus continuous stage models of human information processing: In search of partial output," *Journal of Experimental Psychology: Human Perception and Performance*, Vol. 8, pp. 273–296, April 1982.
25. Miller, J. O., "and continuous models of human information processing: Theoretical distinctions and empirical results," *Acta Psychologica*, Vol. 67, pp. 191–257, June 1988.
26. Ruthruff, E., and J. O. Miller, "Can mental rotation begin before perception finishes," *Memory & Cognition*, Vol. 23, no. 4, pp. 408–424, 1995.
27. Çelik, S., "Mental rotation & mirror image recognition in blinds, blindfolded, and sighted," *Master's thesis, Bogazici University*, 2006.
28. Heller, M. A., ed., *Touch, Representation and Blindness*, New York: Oxford University Press, 2000.
29. Kennedy, J. M., ed., *Drawing & the blind: pictures to touch*, New Haven, Yale University Press, 1993.
30. Millar, S., ed., *Understanding and representing space: Theory and evidence from studies with blind and sighted children*, Oxford UK: Oxford University Press, 1994.
31. Révész, G., ed., *Psychology and art of the blind*, Longmans, Green,, 1950.
32. Heller, M. A., D. D. Brackett, E. Scroggs, H. Steffan, K. Heatherly, and S. Salik, "Tangible pictures: Viewpoint effects and linear perspective in visually impaired people," *Perception*, Vol. 31, no. 6, pp. 747–769, 2002.
33. Arditi, A., J. D. Holtzman, and S. M. Kosslyn, "Mental imagery and sensory experience in congenital blindness," *Neuropsychologia*, Vol. 26, no. 1, pp. 1–12, 1988.
34. Heller, M. A., D. D. Brackett, and E. Scroggs, "Tangible picture matching in people who are visually impaired," *Journal of visual Impairment and Blindness*, Vol. 96, pp. 349–353, 2002b.

35. Lederman, S. J., R. L. Klatzky, C. Chatawayand, and C. D. Summers, "Visual mediation and the haptic recognition of two-dimensional pictures of common objects," *Perception & Psychophysics*, Vol. 47, no. 1, pp. 54–64, 1975.
36. Witkin, H. A., "A cognitive style approach to cross-cultural research," *International Journal of Psychology*, Vol. 2, no. 4, pp. 233–250, 1967.
37. Heller, M. A., K. Wilson, H. Steffan, K. Yoneyama, and D. D. Brackett, "Haptic perceptual selectivity: Embedded figures in the sighted and blind," *Perception*, Vol. 32, no. 4, pp. 499–511, 2003.
38. Heller, M. A., D. D. Brackett, E. Scroggs, A. C. Allen, and S. Green, "Haptic perception of the horizontal by blind and low vision individuals," *Perception*, Vol. 30, no. 5, pp. 601–610, 2001.
39. Millar, S., and Z. Al-Attar, "External and body-centered frames of reference in spatial memory: Evidence from touch," *Perception and Psychophysics*, Vol. 66, no. 1, pp. 51–59, 2004.
40. Millar, S., "Veering revisited: Noise and posture cues in walking without sight," *Perception*, Vol. 28, no. 6, pp. 765–780, 1999.
41. Heller, M. A., and T. D. Joyner, "Mechanisms in the haptic horizontal-vertical illusion: Evidence from sighted and blind subjects," *Attention, Perception, and Psychophysics*, Vol. 53, no. 4, pp. 422–428, 1993.
42. Millar, S., and Z. Al-Attar, "Müller-lyer illusions in touch and vision: Implications for multisensory processes," *Perception & Psychophysics*, Vol. 64, no. 3, pp. 353–365, 2002.
43. Gregory, R. L., "Distortion of visual space as inappropriate constancy scaling," *Nature*, Vol. 199, pp. 678–680, August 1963.
44. Millar, S., and Z. Al-Attar, "Vertical and bisection bias in active touch," *Perception*, Vol. 29, pp. 481–500, 2000.
45. Lederman, S. J., and R. L. Klatzky, "Hand movements: A window into haptic object recognition," *Cognitive Psychology*, Vol. 19, pp. 342–368, 1987.

46. Jansson, G., "The potential importance of perceptual filling-in for haptic perception of virtual object form," in *Eurohaptics Abstracts*, 2001.
47. Ramachandran, V. S., and E. M. Hubbard, "Hearing colors, tasting shapes," *Scientific American*, Vol. 288, no. 5, pp. 52–59, 2003.
48. Cohen, L. G., P. Celnik, A. Pascual-Leone, B. Corwell, L. Faiz, J. Dambrosia, M. Honda, N. Sadato, C. M. Gerloff, M. D. Catala, and M. Hallett, "Functional relevance of cross-modal plasticity in blind humans," *Nature*, 389,, Vol. 389, pp. 180–183, September 1997.
49. Kennedy, J. M., and I. Juveric, "Foreshortening gives forelengthening," *Perception*, Vol. 31, pp. 893–894, 2002.
50. Bodegård, A., A. Ledberg, S. Geyer, E. Naito, K. Zilles, and P. E. Roland, "Object shape differences reflected by somatosensory cortical activation in human," *Journal of Neuroscience*, Vol. 20, pp. 1–5, January 2000.
51. Bodegård, A., S. Geyer, C. Grefkes, K. Zilles, and P. E. Roland, "Hierarchical processing of tactile shape in human brain," *Neuron*, ,, Vol. 31, pp. 317–328, August 2001.
52. Boecker, H., D. Khorram-Sefat, A. Kleinschmidt, K. Merboldt, W. Hänicke, M. Requardt, and J. Frahm, "High resolution functional magnetic resonance imaging of cortical activation during tactile exploration," *Human Brain Mapping*, Vol. 3, no. 3, pp. 236–244, 1995.
53. Servos, P., S. Lederman, D. Wilson, and J. Gati, "fmri-derived cortical maps for haptic shape, texture and hardness," *Cognitive Brain Research*, Vol. 12, pp. 307–313, 2001.
54. Roland, P. E., B. O'Sullivan, and R. Kawashima, "Shape and roughness activate different somatosensory areas in the human brain," *Proceedings of the National Academy of Sciences of the USA*, Vol. 95, pp. 3295–3300, March 1998.
55. Srinivasan, M. A., and R. H. LaMotte, "Tactile discrimination of shape: Responses of slowly and rapidly adapting mechanoreceptive afferents to a step intended in-

- mented into the monkey fingerpad,” *Journal of Neuroscience*, Vol. 7, pp. 1682–1697, June 1987.
56. Sadato, N., V. Ibanez, M. P. Deiber, and M. Hallett, “Gender difference in premotor activity during tactile discrimination,” *NeuroImage*, Vol. 11, pp. 532–540, May 2000.
 57. Sathian, K., S. C. Prather, and J. R. Votaw, “The potential importance of perceptual filling-in for haptic perception of virtual object form,” in *Society for Neuroscience Abstracts*, p. 841.12, 2002.
 58. Stoez, M., M. Zhang, V. D. Weisser, S. C. Prather, H. Mao, and K. Sathian, “Neural networks activate during tactile form perception: Common and differential activity during macrospatial and microspatial tasks,” *International Journal of Psychophysiology*, Vol. 50, pp. 41–49, October 2003.
 59. Tanné-Gariépy, J., E. M. Rouiller, and D. Boussaoud, “Parietal inputs to dorsal versus ventral premotor areas in the macaque monkey: evidence for largely segregated visuomotor pathways,” *Experimental Brain Research*, Vol. 145, pp. 91–103, April 2002.
 60. Diebert, E., M. Kraut, S. Kremen, and J. Hart, “Neural pathways in tactile object recognition,” *Neurology*, Vol. 52, pp. 1413–1417, April 1999.
 61. Malach, R., J. B. Reppas, R. R. Benson, K. K. Kwong, H. J. W. A. Kennedy, P. J. Ledden, T. J. Brady, B. R. Rosen, and R. B. H. Tootell, “Object-related activity revealed by functional magnetic resonance imaging in human occipital cortex,” *Proceedings of the National Academy of Sciences of the USA*, Vol. 92, pp. 8135–8139, August 1995.
 62. Amedi, A., R. Malach, T. Hendler, S. Peled, and E. Zohary, “Visio-haptic object-related activation in ventral visual pathway,” *Nature Neuroscience*, Vol. 4, pp. 324–330, March 2001.
 63. Lancaster, J. L., M. G. Woldorff, and L. M. Parsons, “Convergence of visual and tactile shape processing in the human lateral occipital complex,” *Cerebral Cortex*, Vol. 12, no. 11, pp. 1202–1212, 2002.

64. James, T. W., G. K. Humprey, J. S. Gati, P. Servos, and R. S. M. M. A. Goodale, "Haptic study of three dimensional objects activates extrastriate visual areas.," *Neuropsychologia*, Vol. 40, pp. 1706–1714, 2002.
65. Prather, S. C., J. R. Votaw, and K. Sathian, "Task-specific recruitment of dorsal and ventral visual areas during tactile perception," *Neurophyschologia*, Vol. 42, pp. 1079–1087, 2004.
66. Roder, B., F. Rosler, and E. Hennighausen, "Different cortical activation patterns in blind and sighted humans during encoding and transformation of haptic images," *Psychophysiology*, Vol. 34, pp. 292–307, May 1997.
67. Alivisatos, B., and M. Petrides, "Functional activation of the human brain during mental rotation," *Neuropsychologia*, Vol. 35, pp. 111–118, December 1996.
68. Gauthier, I., W. G. Hayward, M. J. Tarr, A. W. Anderson, P. Skudlarski, and J. C. Gore, "Bold activity during mental rotation and viewpoint-dependent object recognition," *Neuron*, Vol. 34, pp. 161–171, March 2002.
69. Mishkin, M., L. Underleider, and K. Macko, "Object vision and spatial vision: Two cortical pathways," *Trends in Neurosciences*, Vol. 6, pp. 414–417, 1983.
70. Zangaladze, A., C. M. Epstein, S. T. Grafton, and K. Sathian, "Involvement of visual cortex in tactile discrimination of orientation," *Nature*, Vol. 401, pp. 587–590, October 1999.
71. Heller, M. A., "Texture perception in sighted and blind observers," *Perception and Psychophysics*, Vol. 45, pp. 49–54, January 1989.
72. Klatzky, R. L., S. C. Lederman, and C. Reed, "There is more to touch than meets the eye: The salience of object attributes for haptics with and without vision," *Journal of Experimental Psychology*, Vol. 116, no. 4, pp. 356–369, 1987.
73. Oldfield, R. C., "The assessment and analysis of handedness: The edinburgh inventory," *Neuropsychologia*, Vol. 9, pp. 97–113, March 1971.
74. Polat, B., and B. Güçlü, "Mental rotation of tactile objects in blindfolded subjects," in *10. Turkish Neuroscience Congress Abstract Book*, p. 154, April 2011.

75. Streri, A., ed., *Seeing, reaching, touching The relations between vision and touch in infancy*, MIT Press, 1993.
76. Easton, R. D., A. J. Greene, and K. Srivinas, "Transfer between vision and haptics: memory for 2-d patterns and 3-d objects.," *Psychonomic Bulletin and Review*, Vol. 4, no. 3, pp. 403–410, 1997.
77. Easton, R. D., K. Srivinas, and A. J. Greene, "Do vision and haptics share common representations? implicit and explicit memory within and between modalities.," *Journal of experimental psychology: Learning, Memory and Cognition*, Vol. 23, pp. 153–163, January 1997.
78. Reales, J. M., and S. Ballarsteros, "Implicit and explicit memory for visual and haptic objects: cross-modal priming depends on structural descriptions.," *Journal of Experimental Psychology: Learning, Memory and Cognition*, Vol. 25, pp. 644–663, May 1999.
79. Kanwisher, N., M. M. Chun, J. McDermott, and P. J. Ledden, "Functional imaging of human visual recognition," *Cognitive Brain Research*, Vol. 5, pp. 55–67, December 1996.
80. Wiggs, C. L., and A. Martin, "Properties and mechanisms of perceptual priming," *Current Opinion in Neurobiology*, Vol. 8, pp. 227–233, April 1998.
81. Schacter, D. L., E. Reiman, A. Uecker, M. R. Polster, L. S. Yun, and L. A. Cooper, "Brain regions associated with retrieval of structurally coherent visual information," *Nature*, Vol. 376, pp. 587–590, August 1995.
82. James, T. W., J. C. Culham, G. K. Humprey, A. D. Milner, and M. A. Goodale, "Ventral occipital lesions impair object recognition but not object directed grasping: A fmri study," *Brain*, Vol. 126, pp. 2463–2475, September 2003.
83. Kilgour, A. R., B. deGelder, and S. J. Lederman, "Haptic face recognition and prosopagnosia," *Neuropsychologia*, Vol. 42, no. 6, pp. 707–712, 2004.

84. Sadato, N., A. Pascual-Leone, J. Grafman, M. P. Deiber, V. Ibanez, and M. Hallett, "Neural networks for braille reading by the blind.," *Brain*, Vol. 121, no. 7, pp. 1213–1229, 1998.
85. Sadato, N., A. Pascual-Leone, J. Grafman, V. Ibanez, M. P. Deiber, G. Dold, and M. Hallett, "Activation of primary visual cortex by braille reading in blind subjects.," *Nature*, Vol. 380, pp. 526–528, April 1996.
86. Uhl, F., P. Franzen, G. Lindinger, W. Langa, and L. Deecke, "On the functionality of the visually deprived occipital cortex in early blind person," *Neuroscience Letters*, Vol. 124, pp. 256–259, April 1991.
87. Buchel, C., C. Price, R. S. J. Frackowiak, and K. Friston, "Different activation patterns in the visual cortex of late and congenitally blind subjects," *Brain*, Vol. 121, no. 3, pp. 409–419, 1998.
88. Burton, H., A. Z. Synder, T. E. Conturo, E. Akbudak, J. M. Ollinger, and M. E. Raichle, "Adaptive changes in early and late blind: A fmri study of braille reading," *Journal of Neurophysiology*, Vol. 87, pp. 589–607, January 2002.
89. Kosslyn, S. M., A. Pascual-Leone, O. Felician, S. Campasano, J. P. Keenan, and W. L. Thompson, "The role of area 17 in visual imagery. convergent evidence from pet and rtms," *Science*, Vol. 284, pp. 167–170, April 1999.
90. Pascual-Leone, R. H. H. A., "Cortical plasticit associated with braille learning.," *Trends in Cognitive Science*, Vol. 2, pp. 168–174, May 1998.
91. Sathian, K., and A. Zangaladze, "Tactile spatial acuity at the human fingertip and lip: bilateral symmetry and interdigit variability.," *Neurology*, Vol. 46, pp. 1464–1466, May 1996.
92. vanBoven, R., R. Hamilton, T. K. J. P. Keenan, and A. Pascual-Leone, "Tactile spatial resolution in blind braille readers," *Neurology*, Vol. 54, pp. 2230–2236, June 2000.

93. Kiriakopoulos, E., J. Baker, R. Hamilton, and A. Pascual-Leone, "Relationship between tactile spatial acuity and brain activation on brain functional magnetic imaging.," *Neurology, suppl. 2, A307.*, Vol. 52, 1999.
94. Sathian, K., A. Zangaladze, J. M. Hoffman, and S. T. Grafton, "Feeling with the mind's eye.," *NeuroReport*, Vol. 8, pp. 3877–3881, December 1997.
95. Hamilton, R., J. P. Keenan, M. D. Catala, and A. Pascual-Leone, "Alexia for braille following bilateral occipital stroke in an early blind woman," *NeuroReport*, Vol. 7, pp. 237–240, February 2000.
96. Farah, M. J., ed., *The cognitive neuroscience of vision*, Wiley-Blackwell 1st edition, 2000.
97. Kauffman, T., H. Theoret, and A. Pascual-Leone, "Braille character discrimination in blindfolded human subjects," *NeuroReport*, Vol. 13, pp. 1–4, April 2002.