

**ROTENONE INTERFERENCE WITH NEURONAL
TRANSMISSION IN HIPPOCAMPUS**

by

Fatih AKKENTLİ

B.S., in Molecular Biology and Genetics, Bogazici University, 2002

Submitted to the Institute of Biomedical Engineering
in partial fulfillment of the requirements
for the degree of
Master of Science
in
Biomedical Sciences

Boğaziçi University

2010

ACKNOWLEDGMENTS

I am very grateful to my parents, Ümit and Meral Akkentli, for financially supporting me during my time in master's program, and also grateful for their appreciation of my research.

Throughout the implementation of this work, I received the continuous support and guidance from Prof. Dr. Hale Saybaşı. Most of the times, obtaining data was not easy and she encouraged me for the success. She never withhold herself to invest her valuable time on my technical problems in lab.

I also got lots of support and motivation from the nice people of the Biomedical Engineering Institute.

ABSTRACT

ROTENONE INTERFERENCE WITH NEURONAL TRANSMISSION IN HIPPOCAMPUS

Rotenone is a pesticide and insecticide, which causes behavioral, biochemical, and neuropathologic changes in rats that closely resembles PD symptoms in humans. It is known that this pesticide inhibits mitochondrial complex-I, which has an important role in cellular energy production. The object of the current research is to investigate the effect of rotenone on synaptic transmission between neurons in hippocampus, especially its effect on the glutamergic transmission. For this purpose, CA1 pyramidal neuronal response upon low frequency stimulation of Schaffer collateral (0.1 Hz) was recorded by patch clamp tight-seal whole cell recording technique from CA1 pyramidal neuron of rat hippocampus. Different rotenone concentrations were tested on glutamate current; it was observed that rotenone effect on the amplitude of glutamergic currents is dependent on its concentration. To eliminate the rotenone induced cytoplasmic second messenger system effect, ATP was excluded from intra-cellular solution in experiments. Thus, observed effects of rotenone on glutamergic currents occur via its direct effect on cell membrane receptors rather than rotenone-induced intracellular enzymatic or mitochondrial activities.

Keywords: Rotenone, Hippocampus, CA1 pyramidal neuron, Synaptic transmission, Glutamergic Currents, Patch Clamp Tight-Seal Whole Cell Recording Technique.

ÖZET

ROTENONUN HIPOKAMPÜSTEKİ NÖRONAL İLETİŞİM ÜZERİNDEKİ ETKİSİ

Bir tarım ilacı ve haşarat zehiri olan rotenon sıçanlarda insandaki Parkinson semptomlarına çok benzeyen davranışsal, biyokimyasal ve nöropatik değişikliklere sebep olmaktadır. Rotenonun hücre sel enerji üretiminde büyük rolü olan mitokondri kompleks-I' i bloke ettiđi bilinmektedir. Söz konusu çalışmanın amacı rotenonun hipokampüsdeki nöronlar arası sinaptik, özellikle glutamaterjik, geçiş üzerindeki etkisini araştırmaktır. Bu amaçla, sıçan hipokampüsdeki CA1 piramidal hücrelerinden Schaffer kollateralin düşük frekansta (0.1 Hz) uyarılması sonucu elde edilen nöron yanıtları patch-clamp (yama kenetleme) tüm hücre kayıt tekniđi kullanılarak kaydedilmiştir. Farklı rotenon konsantrasyonları glutamat akımı üzerinde test edilmiştir; rotenonun glutamat akımının büyüklüğüne etkisi konsantrasyonla bağlantılıdır. Rotenonun tetikleyebileceđi sitoplazmik ikincil haberci sisteminin etkisini elemine edebilmek için deneylerde ATP hücre içi solusyonundan hariç tutulmuştur. Böylece gözlemlenen glutamat akımı üzerindeki rotenon etkisi hücre içi enzimatik yada mitokondriyal bir aktivite sonucu olmaktan çok rotenonun hücre zarı üzerindeki reseptörlere doğrudan etkisinden kaynaklanır.

Anahtar Sözcükler: Rotenone, Hipokampüs, CA1 piramidal nöron, Sinaptik geçiş, Glutamat akımı, Patch-Clamp Tüm Hücre Kayıt tekniđi

TABLE OF CONTENTS

ACKNOWLEDGMENTS	iii
ABSTRACT	iv
ÖZET	v
LIST OF FIGURES	vii
LIST OF ABBREVIATIONS	viii
1. INTRODUCTION AND MOTIVATION	1
2. HIPPOCAMPUS	3
2.1 Role of Hippocampus	3
2.2 Structural Features of Hippocampus	4
2.3 Connections of Hippocampus	5
3. IONOTROPIC GLUTAMATE RECEPTORS	9
3.1 AMPA Receptors	9
3.2 Kainate Receptors	11
3.3 NMDA Receptors	11
3.4 CELL BIOLOGY OF ROTENONE EFFECT	13
4. MATERIALS AND METHODS	17
4.1 In-vitro Hippocampal Slice Preparation	17
4.2 Whole-Cell Tight Seal Patch-Clamp Recording	17
4.3 Rotenone Application	18
4.4 Data Analysis	18
5. RESULTS	20
6. DISSCUSSION AND CONCLUSION	26
7. FUTURE ASPECTS	30
REFERENCES	31

LIST OF FIGURES

Figure 2.1	Schematic diagram of the intra-hippocampal connections [17].	5
Figure 2.2	Hippocampus layers	6
Figure 2.3	Inside and outside networks of Hippocampus [25].	8
Figure 3.1	Structure of AMPA receptor	10
Figure 5.1	Effect of $1\mu\text{M}$ rotenone on glutamergic currents	21
Figure 5.2	Effect of $1\mu\text{M}$ rotenone from a representative record	21
Figure 5.3	Effect of $0.5\mu\text{M}$ rotenone on glutamergic currents	22
Figure 5.4	Effect of $0.5\mu\text{M}$ rotenone from a representative record	22
Figure 5.5	Effect of $0.1\mu\text{M}$ rotenone on glutamergic currents	23
Figure 5.6	Effect of $0.1\mu\text{M}$ rotenone from a representative record	23
Figure 5.7	Changes in neuronal responses with time and treatment	24
Figure 5.8	Bar graph presentation of the changes in neuronal responses with time	25

LIST OF ABBREVIATIONS

5-HT	5-hydroxytryptamine
ACSF	Artificial cerebrospinal fluid
ATP	Adenosine triphosphate
AMPA	α -amino-3-hydroxy-5-methyl-4-isoxalone propionic acid
CA	Cornu ammonis
CAMKII	Calcium/calmodulin dependent kinase II
DMSO	Dimethylsulfoxide
GLUR	Ionotropic Glutamate Receptor
KA	Kainate
LTP	Long-Term Potentiation
MAP	Microtubule-associated protein
NMDA	N-methyl-D-aspartate
PACAP	Pituitary adenylate cyclase activating polypeptide
PD	Parkinson's Disease
PKA	Protein Kinase A
PKC	Protein Kinase C
ROS	Reactive oxygen species
TH	Tyrosine hydroxylase

1. INTRODUCTION AND MOTIVATION

There is a considerable number of research papers showing the toxicity of pesticides to human health [1–6]. Generally, these adverse effects of pesticides were demonstrated at doses previously declared as safe by the industry and government [7]. Different pesticides have been linked with variety of toxic effects on nervous system and other organs causing carcinogenic effects, hormone system effects and overall irritation [1–6]. Wide exposure of population to pesticide in food products is the main route for the accumulation of pesticide residues in human body. One of the research pointing this concern as a solid threat was performed in United States (U.S.). According to the outcome of this study, big portion of U.S. population has detectable concentrations of multiple pesticide residues in their bodies [7]. One of these pesticides, rotenone, has been shown to induce many of the major symptoms of Parkinson’s disease in rats with long-term exposure [8, 9]. Intravenous administration of rotenone in rats produced effects that are closely resembled to human Parkinson’s disease, including slowing and abnormal movements, unstable posture, unsteady gait and some evidence of tremor [8]. Rotenone is used as a natural broad-spectrum pesticide extracted from the deris plant. It is often formulated as dusts, powders and sprays for use in gardens and on food crops [7]. Rotenone is highly lipophilic. It can easily cross the Blood Brain Barrier and cellular membrane for intracellular entry [10]. Inside the cell, rotenone accumulates at mitochondrial complex-1 as a blocker. This situation results in inhibition of the mitochondrial function and increased production of reactive oxygen species (ROS)[11]. Consequent oxidative stress and decrease in energy production induce neuronal death. Such neurodegenerative effects of chronic rotenone exposure is expected to cause Parkinson’s disease since it causes the death of dopaminergic neurons of the substantia nigra pars compacta [11].

There is considerable number of published work about effects of chronic rotenone exposure [11]. Chronic rotenone exposure selectively degenerates dopaminergic neurons, as a result rotenone causes motor deficiencies in humans and rats [11]. In the

current research, we studied the rotenone effect on neuron functioning in hippocampus- an important brain area for learning and memory. For this reason, our research is directed to assess the effect of rotenone on glutamergic transmission of hippocampal CA1 pyramidal neuron. Any acute influence of rotenone on glutamergic transmission in hippocampus would show that this pesticide has additional degenerative effect besides its interference with mitochondria.

2. HIPPOCAMPUS

Hippocampus is a bilateral structure located in the left and right sides of the brain. The hippocampus in mammals resembles simple cortex. Neocortex has six-layered structure, but there are 3 layers in hippocampus [17]. It consists one basic cell type (pyramidal neuron) and its associated interneurons. It is a structure composed of very densely packaged neurons, which curl in to a tight S shape [12]. Hippocampus is a model system for neurophysiology since it has different neuronal cell types, which are well organized into layers.

2.1 Role of Hippocampus

Damage in hippocampus and its associated pathways (such as fornix) result in major deficit in learning to recognize new stimuli (anterograde amnesia) [13]. Monkeys with damaged hippocampus have problems in memory tasks that require them to associate a stimulus, a picture, with a spatial motor response [14]. Hippocampus has special role in spatial memory acquisition. Humans with temporal lobe damage are also impaired in conditional spatial response and object place memory tasks [15].

It was shown that humans with damaged hippocampus do not have major retrograde amnesia [16]. This means that long-term memory storage does not occur in hippocampus. On the other hand, storage of certain types of memory requires hippocampal function (descriptive declarative info, knowing what, unlike procedural or knowing how) [17].

Hippocampus has also central role in detecting conjunction of related events and objects. Single hippocampal neuron studies made with rhesus monkeys showed that hippocampal neurons fire to complex conjunction of environmental information and features of the objects [18]. This phenomenon enables a particular object in particular space to be remembered/recognized. The position of hippocampus is anatomically ideal

for detecting such conjunctions. It receives highly processed data from association areas such as parietal cortex (position in space), the inferior temporal visual cortex (visual feature of the object), and the superior temporal cortex (auditory feature of a stimulus) [18].

2.2 Structural Features of Hippocampus

The hippocampus is divided into two U-shaped structures; the dentate gyrus and the hippocampus proper (cornu ammonis) [17]. On the basis of differences in cell morphology and fiber projections, hippocampus proper can be further divided [19]; regio superior and regio inferior. The regio superior contains a double row of medium-sized pyramidal cells whose main apical dendrite gives off only small side branches. The regio inferior, which is closed to dentate gyrus, contains the giant pyramidal cells (see Figure 2.1). Hippocampus proper is divided into four fields; CA1-4 (CA stands for cornu ammonis) [20]. Regio superior is called CA1 and the regio inferior is subdivided into CA2 and CA3. CA4 designated the scattered cells inside the hilus of the dentate gyrus. These cells are not lined up like the pyramidal cells of CA3 but they are considered to be included in hippocampus proper since they have pyramidal like characteristics. The CA2 field consisted of CA3-type pyramids [17].

Spines of CA3 pyramidal neurons are much larger than those of CA1 pyramidal neurons. This feature of CA3 neurons is important for mossy fiber connection to CA3 region since dentate gyrus axons require large spines for connection [21]. The cell bodies of pyramidal neurons are larger in CA3 than in CA1. Comparing to CA1 pyramidal, in CA3 cells, branching of apical dendrites starts at points much closer to cell body [22].

Dentate Gyrus has three layers. Granule layer contains densely packed cell bodies of the granule cells. The molecular layer is formed by the apical dendrites of the granule cells and their afferents. The polymorph layer of dentate gyrus contains the initial segments of the granule-cell axons to form the mossy fiber bundle. Axons

in mossy fiber make synapses with pyramidal cells of CA3 region citebook(see Figure 2.2).

The hippocampus proper can be divided into 5 layers. The alveus contains the axons of the pyramidal cells, which are directed towards the fimbria or the subiculum. Second one; the stratum oriens is a layer between the alveus and the pyramidal cell bodies, which contains the basal dendrites of the pyramidal cells. Pyramidal layer contains cell bodies of the pyramids. The other layers are the stratum radiatum and the stratum lacunosum/moleculare. These are the proximal and distal segments of the apical dendritic tree, respectively. The Schaffer collateral system arises from the CA3 pyramids and runs in the stratum radiatum of CA1 to make powerful excitatory synapses with CA1 pyramidals [17].

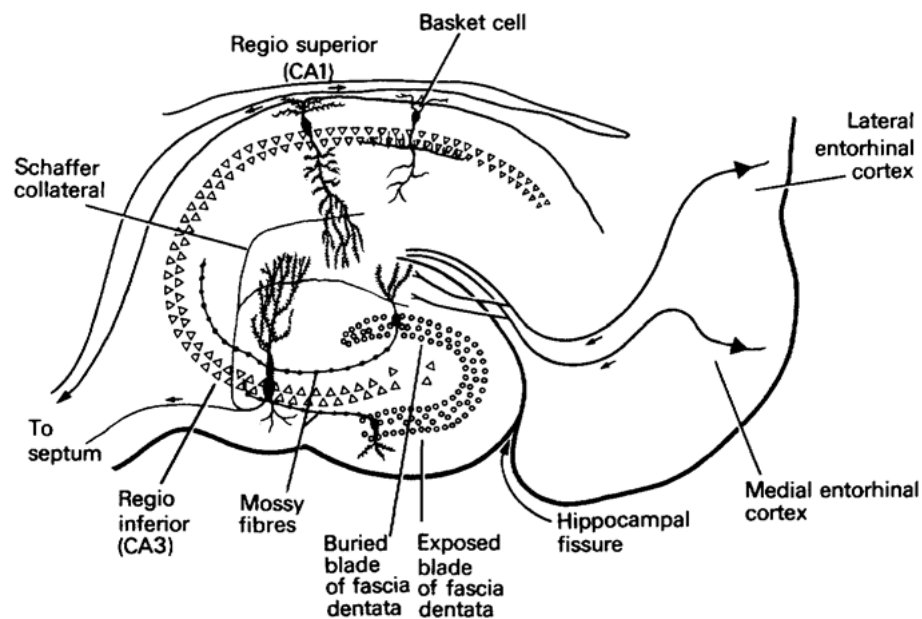

Figure 2.1 Schematic diagram of the intra-hippocampal connections [17].

2.3 Connections of Hippocampus

Conjunction of such wide range of information occurs via hippocampal pathways (see Figure 2.3). Information flow in hippocampus is mostly unidirectional. Tightly packed cell-layers are paths for propagating signals. Signal is received first at dentate

gyrus, propagates to CA3 layer through mossy fiber and it reaches to Schaffer collateral, which rise from CA3 region. Schaffer collateral carry signal to CA1 pyramidal cells. At the end of this path, there is subiculum from which signal travels out of hippocampus to the entorhinal cortex [23]. These layers also contain complex intrinsic circuitry with extensive longitudinal connections [23]. In mossy fiber path, each dentate granule cell contacts approximately about seventy-eight CA3 pyramidal cells. In addition to mossy fibers, CA3 pyramidal cells also receive input from perforant path fibers. Via this projection, each pyramidal neuron may receive about 2300 synapses. CA1 pyramidal cells receive information from the CA3 cells.

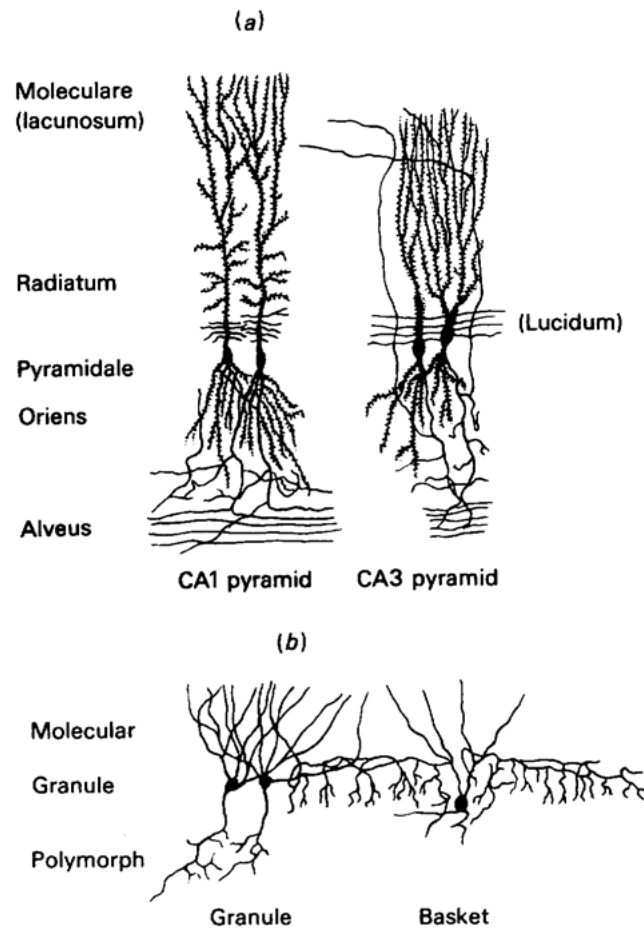

Figure 2.2 a-) CA1 and CA3 pyramidal cells and layers along them b-) Dentate Gyrus neuron and layers [17].

This connection is considered to form a further stage of learning via further classification of signals received by hippocampus from other parts of association neo-

cortex [25]. These further classified signals fired by CA1 cells return to association neocortex through the subiculum, entorhinal cortex, and parahippocampal gyrus (see Figure 2.3). This latest CA1 processing of information in hippocampus is to guide information storage in the cerebral cortex. The Hippocampus receives inputs by two main routes; the entorhinal cortex and the fimbria/fornix. The entorhinal cortex provides hippocampus with extensive input from cerebral cortex. The neocortical areas project to parahippocampal gyrus, which in turn projects to Entorhinal cortex [24]. The parietal cortex projects to parahippocampal gyrus, thus it can potentially influence the hippocampus. The orbitofrontal cortex areas project to entorhinal cortex and entorhinal cortex also receives input from amygdala. The entorhinal cortex project to reach the Dentate Gyrus cells via the perforant path [25].

So, as noted above, hippocampus receives highly processed information from temporal, parietal, and frontal cortices. Hippocampus receives information from neocortex via its main input, the perforant path. There are also inputs from fimbria/fornix from cholinergic cells of medial septum. The hippocampus also receives a noradrenergic input from the locus coeruleus and 5-HT (5-hydroxytryptamine) input from the median raphe nucleus [25].

A major output of the hippocampus arises from the pyramidal cells. They project back to the entorhinal cortex via the subiculum. This projection goes to parahippocampal gyrus and goes further to neocortical areas [18]. Hippocampus can influence the neocortical areas from which it receives input. Second biggest output of hippocampus goes to subiculum from CA1 and then it passes through fimbria/fornix to the anterior thalamus and mamillary bodies. This signal reaches to cingulate cortex through anterior thalamus. Cingulate cortex has connection with supplementary motor cortex. This path explains how hippocampus influence motor output [18].

It has been shown that hippocampus receives large number of synapses to detect conjunction of events, which are detected in different cortical areas. Hippocampus also projects back to neocortical areas from which it receives preliminary information. It also projects to subcortical structures via fimbria/fornix system. Hippocampus is re-

ciprocally connected with parahippocampal gyrus through subiculum and enthorhinal. There are also reciprocal connections from parahippocampal gyrus to many areas of neocortex [25].

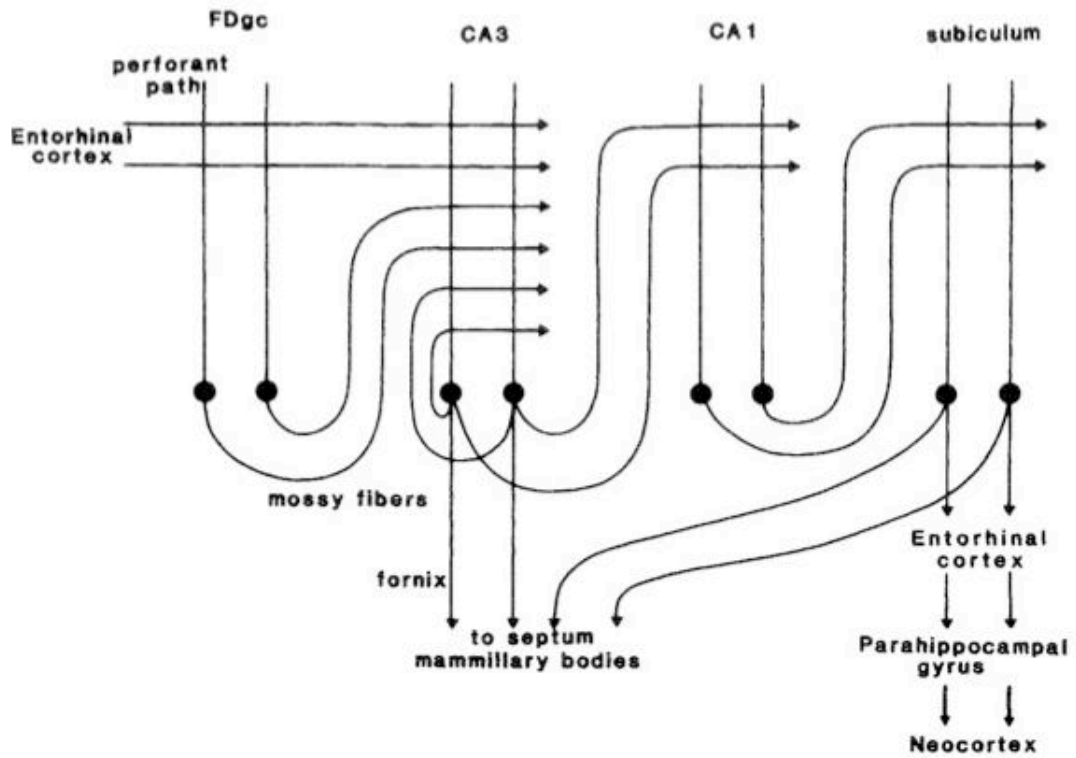

Figure 2.3 Inside and outside networks of Hippocampus [25].

Hippocampus detects the most efficient way to store memory in cortex and directs memory storage there. Here, efficiency means to assign neurons in a convenient way to code for each complex input event. Redundancy is removed from the input signal. Therefore, hippocampus provides guidance for cortical learning via detecting useful conjunction over the whole information that is available.

3. IONOTROPIC GLUTAMATE RECEPTORS

L-glutamate is the major and universal excitatory neurotransmitter of the vertebrate central nervous system. Glutamate excites central neuron and its receptors are classified as ionotropic and metabotropic ones. Metabotropic glutamate receptors do not form ion channels but they are coupled to intracellular signaling system. Ionotropic glutamate receptors are divided into 3 subgroups depending on their selective agonists; NMDA (N-methyl-D-aspartate), kainite, and AMPA (α-amino-3-hydroxy-5-methyl-4-isoxalone propionic acid). NMDA, AMPA, and kainate receptor subunits are encoded by at least six gene families as defined by sequence homology: a single family for AMPA receptors, two for kainate, and three for NMDA [26].

Extracellular and cytoplasmic domains of glutamate receptors specify the character of receptor-channel for ligand recognition, cytoplasmic modification, and interactions with cytoplasmic proteins. Glutamate receptors have three transmembrane domains (M1, M3, and M4) plus a cytoplasm-facing re-entrant membrane loop (M2) (see Figure 3.1) [27]. The presence of re-entrant loop and the transmembrane topology of glutamate is similar to that of potassium channels. Residues in this re-entrant second membrane loop control key permeation properties of the ion channel [28]. It has been shown that glutamate receptors have a pore-forming domain similar to that of potassium channels plus two separate domains that form a ligand-binding site [29].

3.1 AMPA Receptors

Neurotransmitter glutamate is the ligand of AMPA receptors. Unlike NMDA receptors, they form the fast component of synaptic transmission. It can also be activated by artificial glutamate analog AMPA. AMPA receptors are tetrameric channels, which consist of four subunits; GLUR1- GLUR4 [28]. AMPA receptors in CA1 region of hippocampus, mostly, consist of two complexes. These complexes are the combination of GLUR2 subunit either with GLUR1 or GLUR3 [26]. Fast depolarizing response

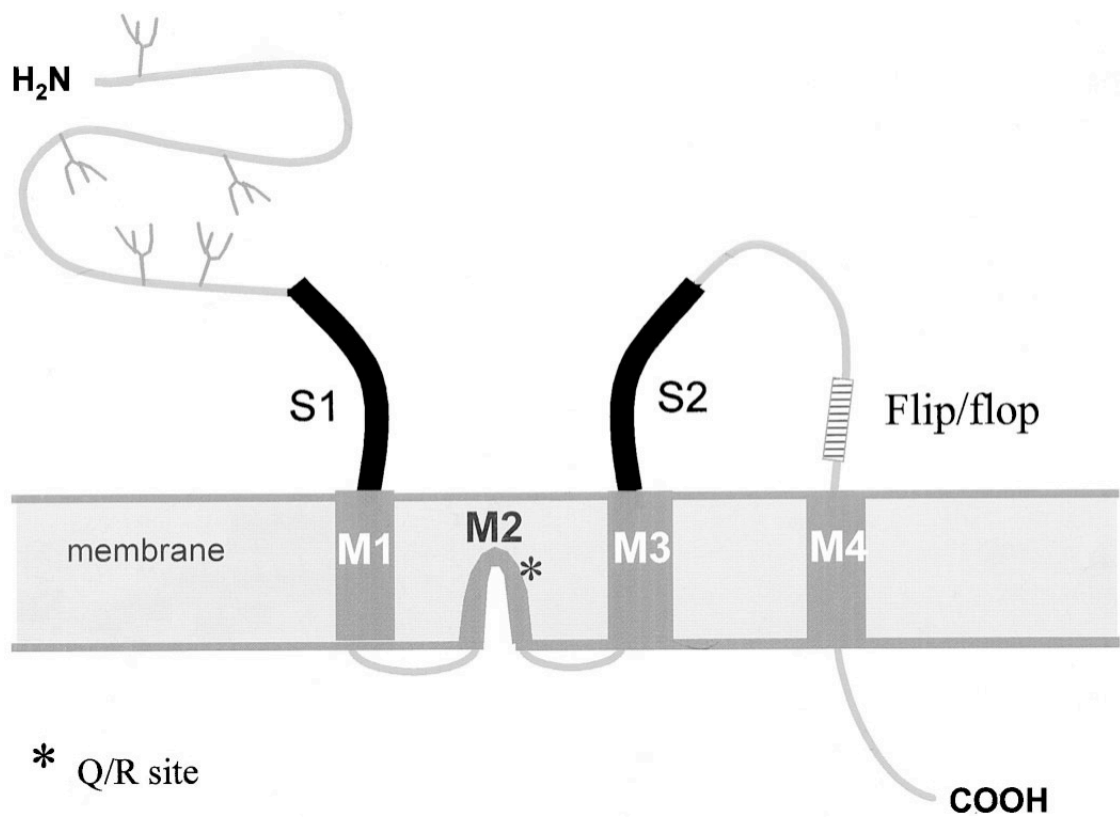

Figure 3.1 Structure of AMPA receptor subunits. Transmembrane structure is shown with two ligand binding domains (S1 and S2) [26].

generated by AMPA receptors (AMPA) via fast sodium ion influx into the cell. The receptor has four ligand binding sites. If two of them are occupied, the channel is open and further binding increases the ion flow. After activation AMPAR undergoes rapid desensitization. So, AMPARs open and close quickly. GLUR2 subunit governs the permeability properties of the receptor, namely, it is responsible for the ion selectivity of receptor. GLUR2 subunit blocks the calcium ion passage through the AMPAR. The major ions, which are conducted through AMPARs, are sodium and potassium [28].

3.2 Kainate Receptors

Kainate receptors (KARs) are activated by glutamate binding, as other glutamate receptors. These receptors are much less studied and less defined in comparison to NMDA and AMPA receptors. Five types of kainate receptors are defined; GLUR5, GLUR6, GLUR7, KA1, KA2. They are tetrameric receptor proteins. Unlike AMPA and NMDA receptors, kainate receptors can be homomeric protein complexes. Kainate receptors are mostly permeable to sodium, potassium ions and their duration of opening is short [26].

3.3 NMDA Receptors

NMDA receptors are tetrameric proteins consists of two NR1 and two NR2 subunits [30]. NR3A and NR3B have an inhibitory effect on receptor activity. Combination of different isoforms of NR1 and NR2 subunits in different brain regions produces NMDA receptors with certain features proper to that region. Glutamate is the ligand needed for NMDA receptor activity. Ligand binding causes 3 dimensional changes in the protein structure resulting in opening of receptor channel. Glycine is an essential co-agonist for NMDA receptor activity [31]. NR1 subunit binds to co-agonist glycine and NR2 subunit binds to neurotransmitter ligand glutamate [32]. Neurotransmitter binds to a conserved amino acid-binding pocket, which is common to all glutamate

receptors. This pocket is formed from two globular domains (S1 and S2), which are adjacent to the M1 domain and the M3-M4 loop (see Figure 3.1) [32]. In addition to the requirement of glutamate and glycine for the receptor activation, NMDA channels are blocked in a voltage dependent way by Mg^{2+} ions [28].

The NMDA receptor is a cation channel; it allows inward flow of Na^+ and Ca^{2+} ions. Therefore its opening enhance membrane depolarization. Apart from that, NMDA receptor is a coincidence detector [28]. Because, as noted above, it allows ion passage only if there is glutamate secretion from presynaptic terminal and post-synaptic membrane depolarization occurs in the same time. So, presynaptic and postsynaptic cells should be active for NMDA receptor (NMDAR) activity. Ca^{2+} ion passage into the cell also activates biochemical-signaling mechanisms in cytoplasm. So, NMDA activity also induces synaptic plasticity [28].

Phosphorylation is another mechanism to regulate NMDA receptor activity. NMDA receptors can be phosphorylated by PKA, PKC and CAMKII [33]. Little is known about regulation of NMDA receptors by CAMKII or PKA [26]. PKC activation has been shown to enhance NMDA receptor function [26]. The activation of NMDA receptors can be inhibited by some phosphatases (calcineurin). NR2 subunits are targets for tyrosine phosphorylation and phosphorylation of tyrosine residues at NMDA receptors increases the receptor activity [34].

NMDA receptors are essential for the generation of a major form of synaptic plasticity, Long-Term Potentiation (LTP). In the course of LTP, glutamate is released from presynaptic terminal. While glutamate binding opens AMPARs it is not sufficient for NMDAR-channel opening. As discussed above, at resting potential, magnesium ion block the pore of NMDAR. Depolarization following AMPARs activity causes removal of magnesium ion from NMDA receptor-channel complex. After that glutamate binding to NMDAR allows calcium ions entrance to the cell. Calcium ion is known to be a second messenger, which trigger cytoplasmic mechanisms. As the result of such intra-cellular biochemical mechanisms, the activity and conductance of AMPARs on membrane are increased [35].

3.4 CELL BIOLOGY OF ROTENONE EFFECT

Rotenone is a member of isoflavone family and it is found in roots and stems of several plants. Rotenone is used as a broad-spectrum pesticide. Since rotenone is a natural product, it is commonly used in organic farming as well [7].

Given the side effects of rotenone usage on human health, rotenone is best known for its involvement with Parkinson's disease (PD). Intravenous delivery of rotenone to rats chronically is used to generate Parkinson's disease model [8]. Hypokinesia, rigidity, hunched posture, unsteady movements and even resting tremor are associated with PD and can be In that study, pituitary adenylate cyclase activating polypeptide (PACAP) resulted in protection against rotenone-induced apoptosis and this occurs by activation of MAPK via PKA, produced with rat via chronic rotenone treatment [8, 9]. Behavioral effects of rotenone treatment in mice, which have been shown as reduction of locomotor activity, catalepsy, and tremor, could be interpreted as similarities to the clinical signs of PD [36]. These motor impairments are due to the loss of nigral dopamine neurons. Rotenone-induced damage is not specific to nigrostriatal system. It causes damages in other sites of the brain [11]. But the prospective damages of rotenone on cognitive functions are not well studied yet [11].

Rotenone is a highly lipophilic compound, because of this property it can easily cross the blood brain barrier [10]. Upon its entrance to cytoplasmic medium, rotenone begins to accumulate at mitochondrial complex-I [11]. Rotenone is a high-affinity specific inhibitor of mitochondrial complex I. The proton-translocating NADH-ubiquinone oxidoreductase (complex I) is the first enzyme complex of the electron transport chain (ETC). Complex 1 is one of the largest and most complicated enzyme systems. It consists of more than 40 protein subunits [37]. This enzyme is embedded in the mitochondrial inner membrane and catalyzes electron transport from NADH to ubiquinone, which is coupled to proton movements. Rotenone inhibition is selective for complex I, non-competitive with endogenous ubiquinone, markedly time-dependent and is likely to involve two binding sites at the ND1 and ND4 subunits [38]. Rotenone acts by antagonizing the semiquinone intermediate stabilized within the complex, blocking the

reduction of ubiquinone by the electron transferred from NADH, through oxidoreduction of cluster N2 [39]. There it occludes the transfer of electrons from iron-sulfur centers to ubiquinone [36].

Neurodegeneration in rotenone-induced PD is not purely a bio-energetic defect due to complex-I inhibition [40]. Rotenone causes neurodegeneration also via multiple mechanisms that include, enhanced production of reactive oxygen species (ROS), oxidative damage [41], induction of apoptosis [42], activation of microglia [43], and acceleration of synuclein aggregation and fibrillation [44]. On the other hand, another study reported that energy deprivation rather than ROS might be the main mechanism of rotenone-induced cell death in dopaminergic neurons [45].

In dissociated culture systems, rotenone does not kill cells via ATP depletion [40]. In a published work, which utilized long-term culture of rodent postnatal midbrain organotypic slices, oxidative damage caused by rotenone was blocked by the antioxidant α -tocopherol (vitamin E). At the same time, α -tocopherol also blocked rotenone-induced reductions in TH protein (tyrosine hydroxylase), an enzyme involved in dopamine. Thus, oxidative damage is a primary mechanism of mitochondrial toxicity in intact dopaminergic neurons [40].

Defect in mitochondrial complex-1 function causes increase in reactive oxygen species (ROS) production. ROS degenerates DNA and protein moieties in neurons. Especially the interaction of ROS with nitric oxide results in generation of peroxynitrite, which is a major factor responsible for the death of dopamine neurons [46]. Rotenone also inhibits proteasome, enzyme that degrades proteins. This dysfunction is showed as one of the important factors in PD generation [47].

Rotenone preferentially damage substantia nigra dopamine neurons in rat brain slices [48], and also induced degeneration of non-dopaminergic neurons in both the basal ganglia and the brainstem [49]. On the other hand, it was reported in vitro models that dopaminergic neurons were more sensitive to rotenone-induced toxicity than other neuronal cells and glial cells [45, 50]

Rotenone acts directly on two targets in the cell; it inhibits complex-I in the mitochondrial respiratory chain [51] and depolymerizes microtubules [52]. Microtubule-depolymerizing activity of rotenone plays a critical role in its selective toxicity on tyrosine hydroxylase-positive (TH) neurons (dopaminergic neurons) in rat embryonic midbrain neuronal cultures [53]. Microtubule depolymerization disrupts vesicular transport, which leads to accumulation of vesicles in the soma. In dopaminergic neurons, leakage of dopamine from the vesicles greatly increases oxidative stress induced by dopamine oxidation, which triggers cell death [53]. Stabilization of microtubules via activation of group III metabotropic glutamate receptor reduces rotenone toxicity on midbrain TH neurons in culture. Microtubule-associated protein (MAP) kinase pathway has role on that effect of mGluR III action on rotenone toxicity [54].

Rotenone-induced dopaminergic neurodegeneration has also been associated with the increased number of activated microglia, macrophages of the brain. In that study, enhanced neurotoxicity of rotenone in striatum was attributed to the release of NADPH oxidase-derived superoxide from activated microglia. Rotenone-induced extracellular superoxide production was catalyzed by NADPH oxidase [43].

Rotenone has an additional effect on cells via ATP depletion. In a published work [55] performed with single striatal cholinergic interneurons, it was found that when interneurons are exposed to rotenone, there is an increase in intracellular concentration of sodium ion. That effect is voltage independent, TTX-insensitive (TTX; tetrodotoxin, blocks voltage-gated sodium channels), and does not require glutamate receptor activation. Concurrent with the Na^+ signal a much larger elevation in intracellular concentration of calcium ion coincides with a significant membrane depolarization. Such effect was attributed to ATP depletion, which comes after rotenone inhibition of complex1 and consequent block of ATP-dependent K^+ channels.

Even a partial inhibition of complex I activity by rotenone is sufficient to promote significant overproduction of mitochondrial-derived ROS in retinal cells and prevention of glutamate transport mediated by Müller glial cells [56]. The re-uptake of neurotransmitters is a function of glial cells and it is performed by Müller glial cells in

the neuroretina. The impairment of glutamate reuptake observed in retinal cells after complex I inhibition by rotenone may generate an excitatory over stimulation which can cause excitotoxicity [56]

Activation of MAPK (microtubulin activated protein kinase) by PKA (Protein kinase A) was shown to oppose apoptotic effects of rotenone in differentiated PC12 cells [57]. In that study, pituitary adenylate cyclase activating polypeptide (PACAP) resulted in protection against rotenone-induced apoptosis and this occurs by activation of MAPK via PKA.

4. MATERIALS AND METHODS

4.1 In-vitro Hippocampal Slice Preparation

Sprague Dawley rats on postnatal days 10-25 were provided from Experimental Animal Center, Marmara University (Istanbul). The experiments were conducted in accordance with the guidelines of Animal research Committee of Bogazici University. Hippocampal slices were prepared as previously described (Richard, 1981). Transversal slices (200 μ M in thickness) were prepared by using vibroslicer and incubated in carbogen gas (95%O₂-5%CO₂) aerated artificial cerebrospinal fluid (ACSF) containing (mM): *NaCl* 125, *KCL* 2.5, *CaCl₂* 2.0, *MgCl₂* 1.0, *NaH₂PO₄* 1.25, *NaHCO₃* 26, *Glucose* 10. Slices were maintained in ACSF solution for at least 45 minutes before performing experiments. During recordings, slices were kept submerged in a chamber perfused with ACSF, which was saturated with carbogen gas. All experiments were performed at room temperature.

4.2 Whole-Cell Tight Seal Patch-Clamp Recording

To take whole-cell patch-clamp records from pyramidal neurons in the CA1 layer of hippocampus, slices were transferred to a recording chamber placed on a microscope stage. Healthy hippocampal CA1 neurons were visualized by using a CCD camera (sensicam qe 672 LS, pco.imaging, Germany). Borosilicate recording-electrodes (with 4-7M Ω resistance) were made with a micropipette puller PP-81 (Narishige, Japan) from borosilicate capillaries (Hilfenberg, Germany). The composition of standard pipette solution for recording post-synaptic currents was (mM): *CsF* 135.0, *CsCl* 5.0, *EGTA* 10.0, *HEPES* 10.0, *CaCl₂* 1.0 (pH 7.3). Cesium (*Cs⁺*) was used as the main cation to substitute (*K⁺*) ions and to suppress potassium conductance and fluoride (*F⁻*) is used as main anion, which blocks the chloride conductance and calcium dynamics (Kay et al., 1986). At the time of recording, stimuli (0.1 Hz) were applied to Schaffer collateral

pathway of the hippocampal slice through a tungsten bipolar stimulation electrode. To obtain a whole-cell clamp configuration, gigaohm seal formed between cell membrane and recording pipette was disrupted by a slight negative pressure application at a holding potential of -60 mV. Patch-clamp amplifier was EPC-7 (List Medicals, Darmstadt, Germany), analog signals were filtered with a 3 kHz Bessel filter and converted into digital signals by ITC-18 A/D converter (Instrutech, USA) at 25 kHz. Stimulating current-pulses were generated from computer and delivered via a stimulus isolation unit (Iso-Flex, Israel). The glutamatergic currents were recorded at a slightly depolarized voltage value (-50 mV) and rotenone was applied to observe its effect on glutamergic currents only after stable amplitude of control currents were reached.

4.3 Rotenone Application

Rotenone (purchased from Sigma) was prepared as stock in dimethylsulfoxide (DMSO) and was diluted directly in the ACSF, and applied via the perfusion system at 0.1, 0.5, and 1 μ M of final concentrations.

Control values were recorded for 3 minutes and neurons were treated with rotenone only if their synaptic current amplitude was stable. Then, rotenone was applied to hippocampal slices for 3 minutes, following this wash with ACSF was performed for 6 minutes. For the early (first 3minutes) and the late (second 3minutes) wash periods, rotenone effects on the neuronal responses were analyzed separately.

4.4 Data Analysis

Strathclyde-WCP and MATLAB-R2009b was used for data acquisition and analysis. SPSS13 was used for statistics. Peak values of current response waves of neurons were analyzed for control (before rotenone treatment), rotenone application and wash periods of each experiment. Current response waves were plotted by averag-

ing 18 sweeps of the glutamatergic responses. All data expressed as the mean \pm SEM and statistical significance was assessed using one-way ANOVA followed by Dunnett's multiple comparison test and $P < 0.05$ was considered significant.

5. RESULTS

The responses of CA1 pyramidal cells were recorded by patch clamp tight seal whole cell recording technique at a holding potential of -50 mV. Whole cell currents were recorded from the soma of the hippocampal pyramidal neurons. Neuronal responses, inward postsynaptic currents, were evoked by a single brief current pulse, which was delivered to the Schaffer collateral pathway. Additionally, intracellular pipette solution does not contain ATP to exclude the contribution of intracellular mechanisms, so, the currents that originate only from membrane receptors are recorded.

Rotenone ($1\mu\text{M}$) effect was tested on neuronal responses. In the period of 3 minutes of rotenone application, amplitude of glutamatergic response was not affected, but during wash, rotenone inhibition on neuronal currents was observed (see Figure 5.1). In the late phase of wash, there was significant decrease of $48\pm 6\%$ ($n=5$) in average current responses. The averaged current waveforms from an experiment representing the effect of $1\mu\text{M}$ rotenone application are illustrated in 5.2. Observed rotenone-induced inhibition was irreversible.

Different concentrations of rotenone were also tested. $0.5\mu\text{M}$ final concentration of rotenone also inhibited neuronal responses, but the inhibition was less than the one observed with $1\mu\text{M}$ concentration of rotenone. $0.5\mu\text{M}$ of rotenone application for 3 minutes significantly decreased neuronal responses for $34\pm 6\%$ ($n=5$) (see Figure 5.3). As in the case of $1\mu\text{M}$ rotenone treatment, observed decrease in glutamergic currents after application of $0.5\mu\text{M}$ rotenone was irreversible. The data from an experiment representing the effect of $0.5\mu\text{M}$ rotenone application is plotted as 5.4. Application of $0.1\mu\text{M}$ rotenone for 3 minutes was found to have no effect on glutamergic transmission ($n=6$)(see Figure 5.5). The data of a representative $0.1\mu\text{M}$ rotenone experiment is shown in 5.6. The inhibitory effect of rotenone on glutamatergic transmission is dose dependent and irreversible (5.7- 5.8).

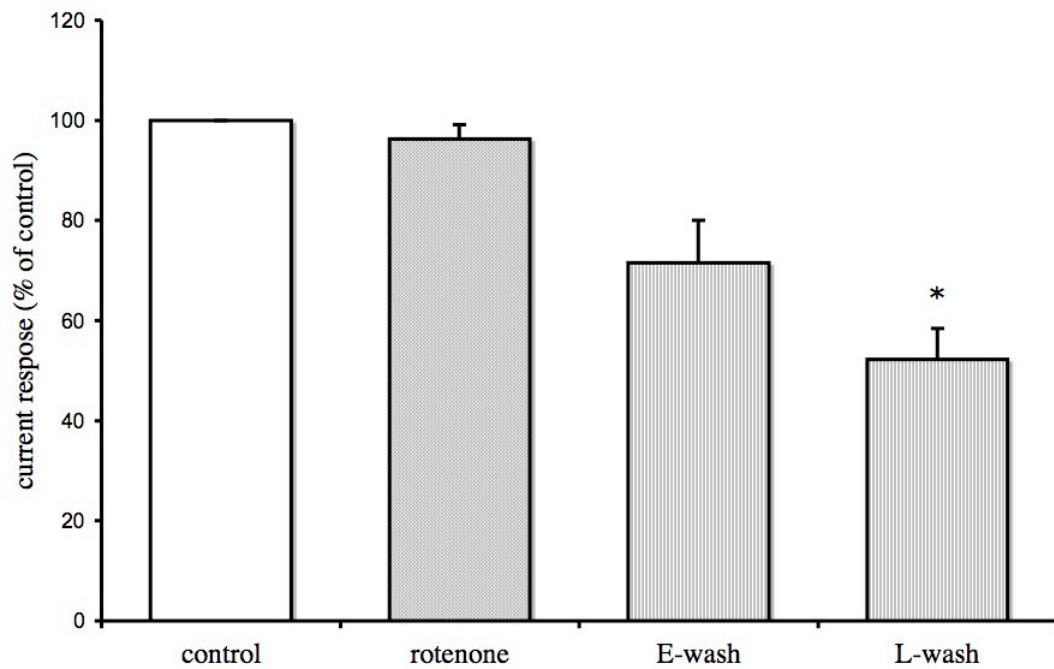

Figure 5.1 Effect of $1\mu\text{M}$ rotenone on glutamergic currents in CA1 pyramidal neurons. Peak current levels observed during rotenone and wash period are expressed in ratio to control ones. In the late wash period, level of glutamergic currents is decreased (48%) significantly. Error bars show mean of error. The significance level is $P < 0.05$ in comparison to control.

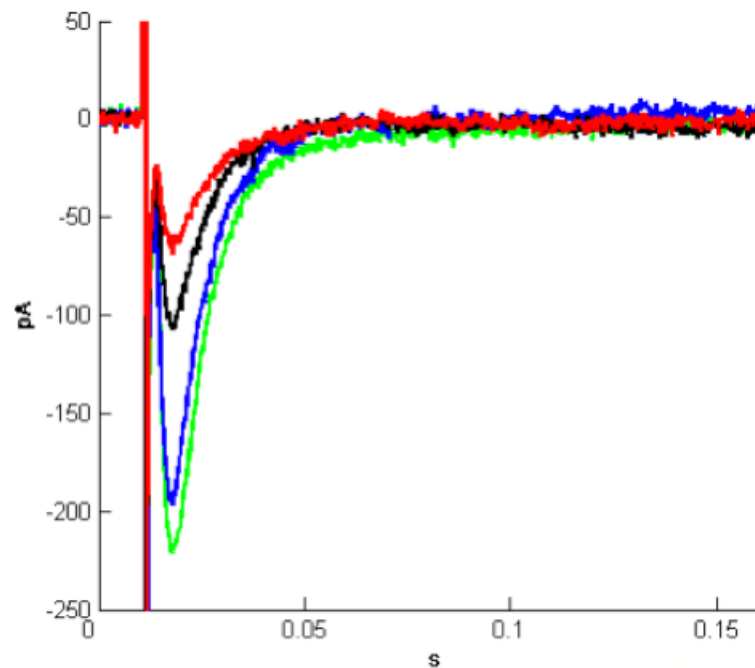

Figure 5.2 Effect of $1\mu\text{M}$ rotenone on glutamatergic current waveforms from a representative single experiment. Control (green), rotenone treatment (blue), early wash period -post-treatment- (black) and the following late wash period (red).

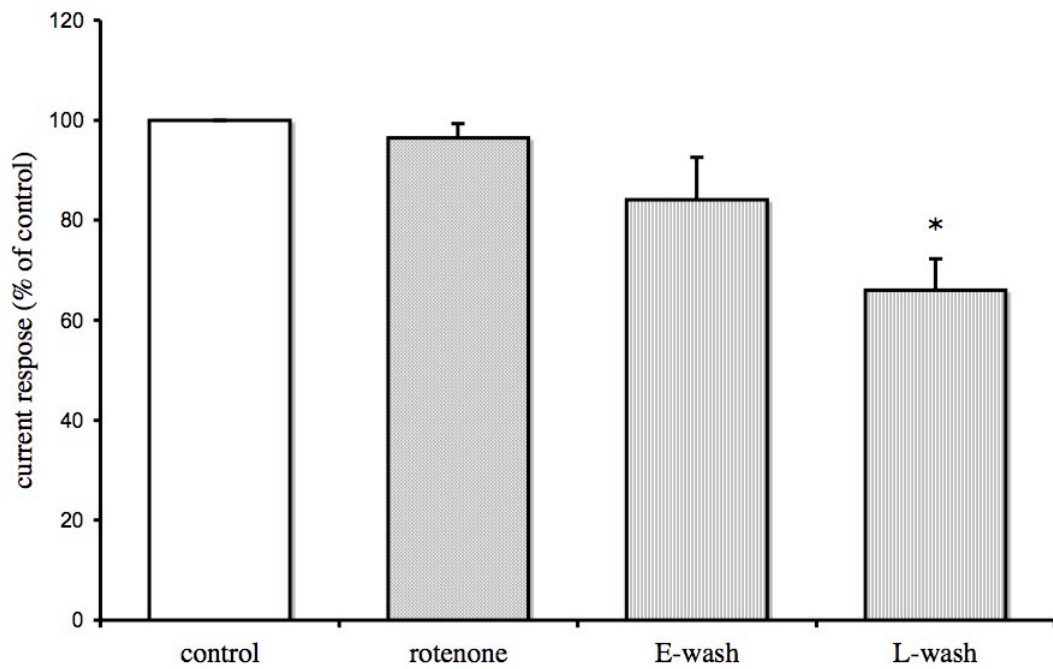

Figure 5.3 Effect of $0.5\mu\text{M}$ rotenone on glutamergic currents in CA1 pyramidal neurons. Peak current levels observed during rotenone and wash period are expressed in ratio to control ones. In the late wash period, level of glutamergic currents is decreased (34%) significantly. Error bars show mean of error. The significance level is $P < 0.05$ in comparison to control.

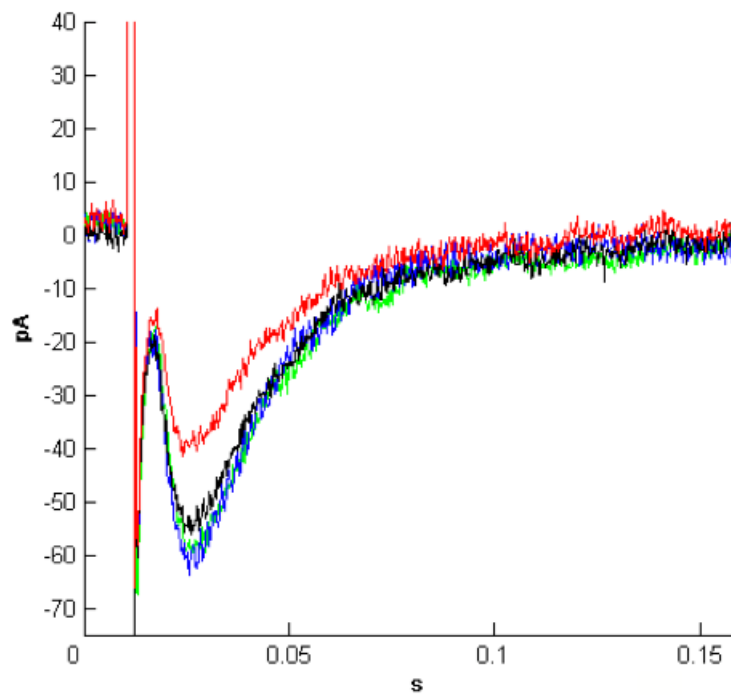

Figure 5.4 Effect of $0.5\mu\text{M}$ rotenone on glutamatergic current waveforms from a representative single experiment. Control (green), rotenone treatment (blue), early wash period -post-treatment- (black) and the following late wash period (red).

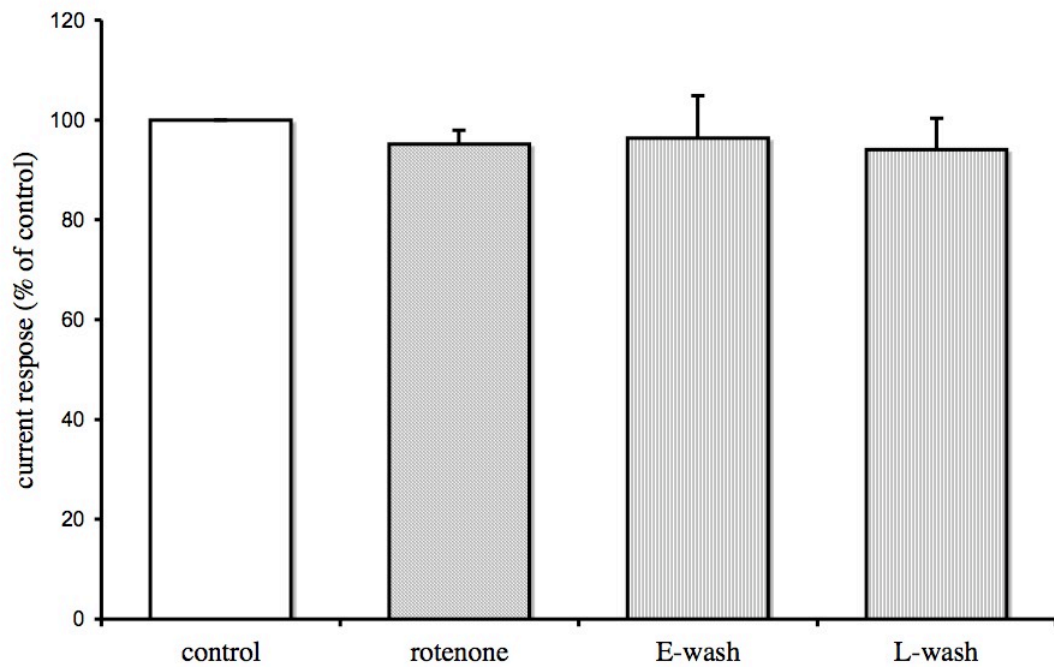

Figure 5.5 Effect of $0.1\mu\text{M}$ rotenone on glutamergic currents in CA1 pyramidal neurons. Peak current levels observed during rotenone and wash period are expressed in ratio to control ones. $0.1\mu\text{M}$ rotenone treatment do not have significant impact on glutamatergic currents. Error bars show mean of error. Error bars show mean of error.

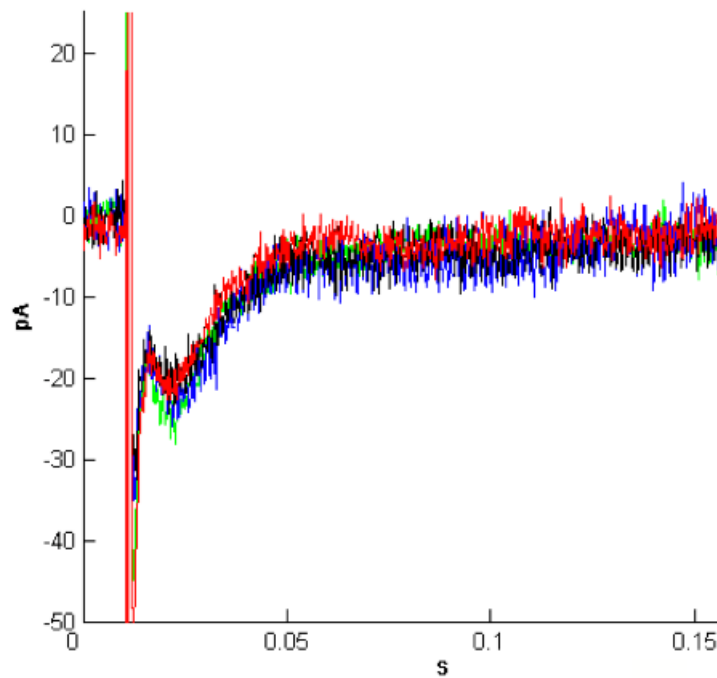

Figure 5.6 Effect of $0.1\mu\text{M}$ rotenone on glutamatergic current waveforms from a representative single experiment. Control (green), rotenone treatment (blue), early wash period -post-treatment- (black) and the following late wash period (red).

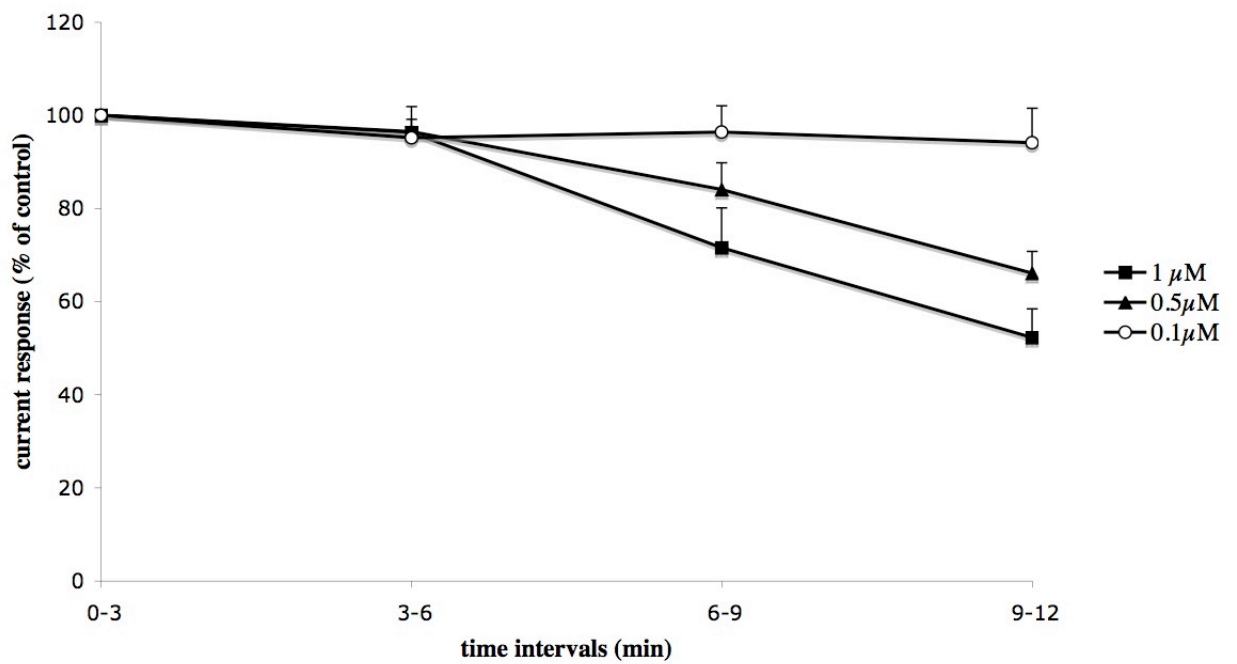

Figure 5.7 Changes in neuronal responses with time and treatment (averages of every three minutes) for 1, 0.5 and 0.1 μM doses of rotenone application. 0-3 minutes interval represents control. Rotenone was applied between the 3rd and 6th minutes. The former and latter halves of the 6 minutes long aCSF wash are designated as E-wash and L-wash, respectively. While E-wash covers the period between the 6th and 9th minutes of the experiment, L-wash covers the 9th-12th minute time interval. It is shown that rotenone's effect on glutamatergic currents is time dependent and irreversible.

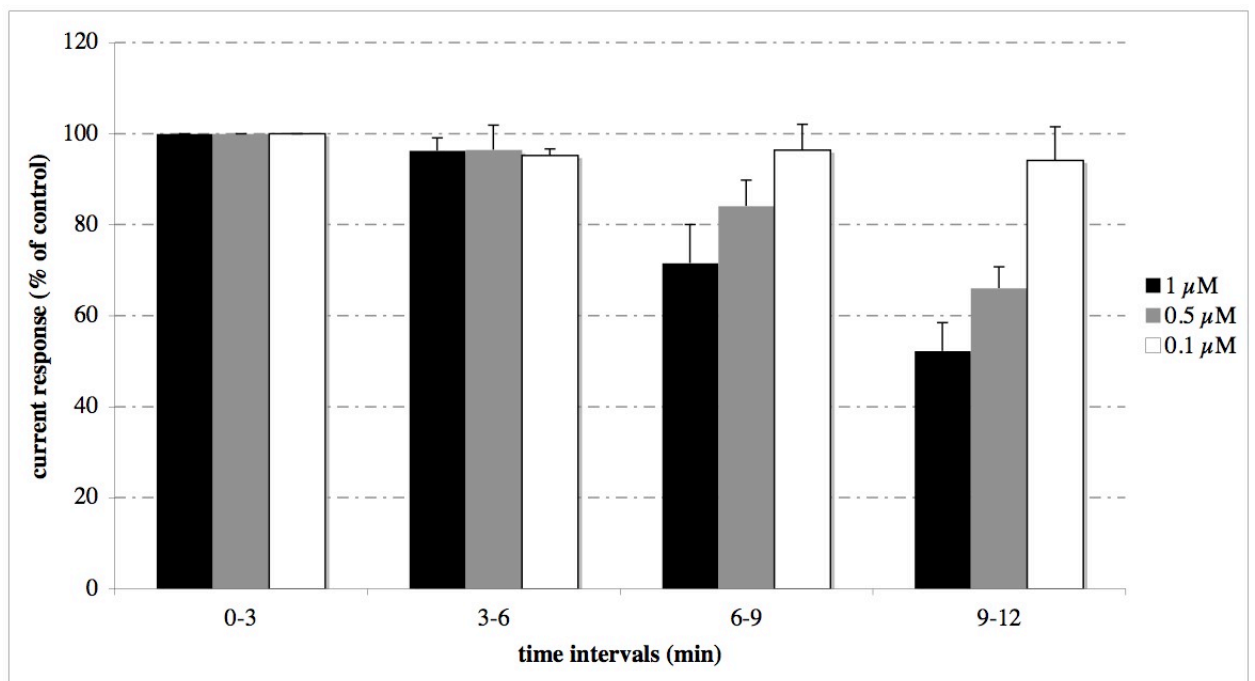

Figure 5.8 Bar graph presentation of the changes in neuronal responses with time and treatment (averages of every three minutes) for 1, 0.5 and 0.1 μM doses of rotenone application. Although not significant, the decrease in the E-wash phase follows a statistically significant dose dependent response decrease observed in the L-wash phase. Observed decreases in the E-wash phase are 29%, 16% and 4% for 1 μM , 0.5 μM and 0.1 μM , respectively. The significance level is * $P < 0.05$ in comparison to control.

6. DISSCUSSION AND CONCLUSION

Rotenone is a subject of investigation in neuroscience because it causes neuropathic characters in rats that closely resembles to PD in humans [8]. At neuronal level, it is used as a model to study the effect of mitochondrial inhibition [11]. As a consequence of mitochondrial inhibition, energy depletion and the generation of reactive oxygen species produce different effects in neurons of different brain regions for different conditions. Understanding this diversity in rotenone effect on neurons is important to depict the variance in functioning of different neuron types.

Rotenone is known for its toxicity in dopaminergic neurons and that's how its disruptive effect in brain forms a model for PD [11]. Unlike most of the rotenone research, our investigation was performed on glutamate receptor responses to study neuronal transmission, not survival. In this study, we showed that the neuronal responses of pyramidal neurons in CA1 region of hippocampus are decreased with rotenone treatment. Single-Neuron responses evoked by Schaffer collateral stimulation were inhibited by 0.5 and 1 μ M concentrations of rotenone exposure. Unlike the effect of chronic rotenone exposure on neuronal survival, here, even a very brief application of rotenone (0.5 μ M/1 μ M for 3min) from perfusion solution was adequate to inhibit the neuronal transmission.

Since 12 hours of 10 μ M rotenone treatment was found to produce no serious toxicity on glutamergic neurons [58], the inhibition of glutamergic response observed in our study is unlikely to be the result of neuron degeneration caused by exposure to rotenone (1 μ M for 3 minutes). In 0.1 μ M rotenone experiments and control period of others, no inhibition of neuronal responses was observed, while dose dependent inhibition was observed for 0.5 μ M and 1 μ M concentrations of rotenone exposure. This indicates inhibition of glutamergic responses is caused by rotenone application rather than some unspecific interference in experiments.

Although rotenone primarily inhibits mitochondria complex I, degeneration of dopaminergic neurons via rotenone treatment does not require the inhibition of complex I [59]. Rotenone depolymerizes microtubules, components of cell skeleton that are involved in vesicular transportation [52]. The stabilization of microtubules with Taxol prevents rotenone's selective damage to dopaminergic and serotonergic neurons [58]. The parkin protein prevents rotenone damage on dopaminergic neurons via stabilizing microtubules [60]. Similarly, neurotrophic factors and group III metabotropic glutamate receptor activity inhibits rotenone's selective toxicity on dopaminergic neurons by stabilizing microtubules [54, 61].

Microtubule depolymerization disrupts vesicular transport and this causes vesicle accumulation in the soma [53]. The constitutive leakage of neurotransmitters from vesicles makes this situation toxic for the dopaminergic neurons because increased cytosolic concentration of dopamine elevates oxidative stress from dopamine oxidation [58]. Rotenone does not cause this kind of toxicity in glutamergic neurons because glutamate cannot be oxidized [58]. Although rotenone exposure to glutamergic neurons lacks such oxidative damage in the cell soma, it still depolymerizes the microtubules at same extent with dopaminergic neurons [53]. It causes same situation with respect to vesicular transportation, disruption of glutamate transportation through axons.

In our experiments, observed irreversible rotenone interference with glutamergic transmission might result from deficit in glutamate transportation to the presynaptic terminals. So, rotenone treatment may decrease the level of presynaptic release of glutamate. This situation would cause lesser stimulation of the postsynaptic neuron. Therefore, inhibitory effect of rotenone on neuronal responses might be presynaptic rather than any effect of rotenone on postsynaptic neuron. On the other hand, in literature, rotenone's effect on microtubules was investigated with neuron cultures and rotenone treatment in these studies was applied for 12 hours [53, 58–60]. It seems that microtubule disruption with rotenone interference may require rather chronic exposure. In our experiments, the time period of rotenone exposure of slices was very brief (3 minutes). It should also be noted that, we do not use ATP in our pipette's intracellular environment, which is a situation may result in direct rotenone-caused obstruction on

microtubules.

Unlike our findings of rotenone-inhibition of glutamergic responses, it was showed that rotenone can enhance NMDA responses [62]. This patch-clamp study was made with rat midbrain slices. Another study noted that this potentiating effect of rotenone on NMDA receptors is the result of removal of magnesium block from receptor gate [63]. Additionally, this effect of rotenone requires tyrosine kinase activity [63]. There are certain differences, which can account for the contradictory results, between our study and the indicated ones [62, 63]. Unlike these studies, which perform 30 minutes of rotenone ($0.1 \mu\text{M}$) treatment, slices utilized in our experiments were exposed to rotenone for brief period of time (3 minutes). Rotenone at $0.1\mu\text{M}$ concentration may have different effects in cell comparing to $0.5\text{-}1 \mu\text{M}$ levels of it. If 30 min exposure time is needed to see such effect on NMDA receptors, we might miss it because of brief exposure time. Apart from that, ATP was excluded from our intracellular pipette solution to eliminate any intra-cellular enzymatic activities from our observation. By this way, neuronal responses can be traced better at the level of receptors and ion channels without any enzymatic interference. Lack of ATP in intracellular pipette solution would rule out any possible tyrosine-kinase activity since this enzyme requires ATP to function.

Acute action of rotenone on nigral dopamine neurons was investigated via patch-clamp technique [64]. Rotenone ($1\mu\text{M}$) application of slices for 10 minutes induced the generation of reactive oxygen species (ROS) [64]. In the same work, it was also showed that same rotenone treatment causes activation of ATP sensitive potassium channels (K-ATP) and suggested that ROS induces K-ATP activity. Through KATP action, outward current was observed [64]. This outward current might pointed to be responsible from the decrease in total (inward) current observed in our experiments. If rotenone application for 10 minutes causes generation of ROS, 3 minute time period may also cause similar effect. Even if it is assumed that there is ROS generation in our slices during 3 minutes of rotenone treatment, there would not be any K-ATP activity since we do include Cesium salts in our pipette solution which would block all kinds of potassium channels.

Rotenone was also found to decrease field potentials (fEPSP) slightly in CA1 region of hippocampus [65]. 30 minutes of 1 μ M rotenone application was found to decrease fEPSP for 17%. Comparing to our study, rotenone's effect was very faint. Glutamergic transmission was isolated in our experiments and rotenone may have bigger inhibitory effect on glutamergic currents comparing to it has on total field responses of many neurons. Apart from that ATP lacking intracellular pipette solution used in our experiments may uncover the effect of rotenone on glutamergic responses.

As a conclusion, here, it has been shown that rotenone has an acute inhibitory effect on glutamergic transmission in ATP deprived conditions. Given the impact and exposure time of rotenone, the experimental conditions utilized in our work define a situation in which rotenone effect can be sharper comparing to the those in other literature that investigated some other electrophysiological and neurodegenerative features of the broad-spectrum pesticide, rotenone. Hence, our study isolated the more rotenone-sensitive conditions for neuronal transmission as; in case of ATP deprivation rotenone can have serious dose-dependent inhibition on, specially, glutamergic receptors.

7. FUTURE ASPECTS

Consequently, rotenone's effect on neuronal responses may stem from various reasons. If the rotenone's inhibitory effect is microtubule dependent, pretreatment of the brain tissue with microtubule stabilizing drug, taxol, would abolish the rotenone-effect on glutamergic channels. Although cesium contained in our intracellular solution should block K-ATP channels, to re-check K-ATP channel involvement, a specific K-ATP blocker (rather than broad spectrum potassium channel blockers like Cs or Ba) can be used. If K-ATP sourced outward current underlie the rotenone-inhibition, pretreatment with ouabain (K-ATP blocker) should prevent glutamergic current inhibition.

Since ATP is excluded from our intracellular solution, most of the rotenone-induced cytoplasmic activities should be eliminated. On the other hand, ROS generated by rotenone action in cytoplasm may interfere with glutamergic receptor activities with some unknown mechanism. To test this possibility, hippocampal tissue can be pre-treated with antioxidants. If rotenone inhibits glutamergic transmission indirectly via ROS induced mechanism, antioxidant pre-treatment would decrease the level of rotenone-induced inhibition.

REFERENCES

1. Abballe, A., M. Guarino, F. Taggi, M. E. Traina, E. Urbani, S. Valentini, and E. De Felip, "Maternal blood levels of persistent organic pollutants can be used to estimate in utero exposure," *Ann Ist Super Sanita*, Vol. 44, no. 3, pp. 281–291, 2008.
2. Alavanja, M. C., J. A. Hoppin, and F. Kamel, "Health effects of chronic pesticide exposure: cancer and neurotoxicity," *Annu Rev Public Health*, Vol. 25, pp. 155–197, 2004.
3. Alavanja, M. C., M. H. Ward, and P. Reynolds, "Carcinogenicity of agricultural pesticides in adults and children," *J Agromedicine*, Vol. 12, no. 1, pp. 39–56, 2007.
4. Andersen, H. R., I. M. Schmidt, P. Grandjean, T. K. Jensen, E. Budtz-Jorgensen, M. B. Kjaerstad, J. Baelum, J. B. Nielsen, N. E. Skakkebaek, and K. M. Main, "Impaired reproductive development in sons of women occupationally exposed to pesticides during pregnancy," *Environ Health Perspect*, Vol. 116, pp. 566–572, Apr 2008.
5. Andreotti, G., L. E. Freeman, L. Hou, J. Coble, J. Rusiecki, J. A. Hoppin, D. T. Silverman, and M. C. Alavanja, "Agricultural pesticide use and pancreatic cancer risk in the agricultural health study cohort," *Int J Cancer*, Vol. 124, pp. 2495–2500, May 2009.
6. Beseler, C. L., L. Stallones, J. A. Hoppin, M. C. Alavanja, A. Blair, T. Keefe, and F. Kamel, "Depression and pesticide exposures among private pesticide applicators enrolled in the agricultural health study," *Environ Health Perspect*, Vol. 116, pp. 1713–1719, Dec 2008.
7. CDC, "Third national report on human exposure to environmental chemicals." NCEH Pub., 2005.
8. Betarbet, R., T. B. Sherer, G. MacKenzie, M. Garcia-Osuna, A. V. Panov, and J. T. Greenamyre, "Chronic systemic pesticide exposure reproduces features of parkinson's disease," *Nat Neurosci*, Vol. 3, pp. 1301–1306, Dec 2000.
9. Cannon, J. R., V. Tapias, H. M. Na, A. S. Honick, R. E. Drolet, and J. T. Greenamyre, "A highly reproducible rotenone model of parkinson's disease," *Neurobiol Dis*, Vol. 34, pp. 279–290, May 2009.
10. Dauer, W., and S. Przedborski, "Parkinson's disease: mechanisms and models," *Neuron*, Vol. 39, pp. 889–909, Sep 2003.
11. Cicchetti, F., J. Drouin-Ouellet, and R. E. Gross, "Environmental toxins and parkinson's disease: what have we learned from pesticide-induced animal models?," *Trends Pharmacol Sci*, Vol. 30, pp. 475–483, Sep 2009.
12. Kötter, R., and K. E. Stephan, "Useless or helpful? the "limbic system" concept," *Rev Neurosci*, Vol. 8, pp. 139–145, Apr-Jun 1997.
13. Milner, B., "Disorders of learning and memory after temporal lobe lesions in man," *Clin Neurosurg*, Vol. 19, pp. 421–446, 1972.
14. Gaffan, D., "Hippocampus: memory, habit and voluntary movement," *Philos Trans R Soc Lond B Biol Sci*, Vol. 308, pp. 87–99, Feb 1985.

15. Petrides, M., "Deficits on conditional associative-learning tasks after frontal- and temporal-lobe lesions in man," *Neuropsychologia*, Vol. 23, no. 5, pp. 601–614, 1985.
16. Squire, L. R., "Mechanisms of memory," *Science*, Vol. 232, pp. 1612–1619, Jun 1986.
17. O'Keefe, J., and L. Nadel, *The Hippocampus as a Cognitive Map*, Oxford University Press, 1978.
18. Van Hoesen, G. W., "The parahippocampal gyrus. new observations regarding its cortical connections in the monkey," *Trends in Neurosciences*, Vol. 5, pp. 345–350, 1982.
19. BLACKSTAD, T. W., "Commissural connections of the hippocampal region in the rat, with special reference to their mode of termination," *J Comp Neurol*, Vol. 105, pp. 417–537, Oct 1956.
20. LORENTE DE No, R., "Studies on the structure of the cerebral cortex. continuation of the study of the ammonic system," *J. Psychol. Neurol*, Vol. 46, pp. 113–177, 1934.
21. Andersen, P., T. V. Bliss, T. Lomo, L. I. Olsen, and K. K. Skrede, "Lamellar organization of hippocampal excitatory pathways," *Acta Physiol Scand*, Vol. 76, pp. –5, May-Jun 1969.
22. Frotscher, M., P. Kugler, U. Misgeld, and K. Zilles, "Neurotransmission in the hippocampus," *Adv Anat Embryol Cell Biol*, Vol. 111, pp. 1–103, 1988.
23. D, A., and L. P, *Hippocampal Neuroanatomy*, Oxford University Press, 2006.
24. G, A. D., *The nervous system*, ch. Memory: Anatomical organization of candidate brain regions, pp. 211–294. American Physiological Society, 1987.
25. JL, M., Weinberger, N. M, and Lynch, *Brain Organization and Memory : Cells, Systems, and Circuits*, Oxford University Press, 1992.
26. Dingledine, R., K. Borges, D. Bowie, and S. F. Traynelis, "The glutamate receptor ion channels," *Pharmacol Rev*, Vol. 51, pp. 7–61, Mar 1999.
27. Kuner, T., C. Beck, B. Sakmann, and P. H. Seeburg, "Channel-lining residues of the ampa receptor m2 segment: structural environment of the q/r site and identification of the selectivity filter," *J Neurosci*, Vol. 21, pp. 4162–4172, Jun 2001.
28. B, H., *Ion channels of excitable membranes*, Sinauer associates, 2001.
29. Paas, Y., "The macro- and microarchitectures of the ligand-binding domain of glutamate receptors," *Trends Neurosci*, Vol. 21, pp. 117–125, Mar 1998.
30. Béhé, P., P. Stern, D. J. Wyllie, M. Nassar, R. Schoepfer, and D. Colquhoun, "Determination of nmda nr1 subunit copy number in recombinant nmda receptors," *Proc Biol Sci*, Vol. 262, pp. 205–213, Nov 1995.
31. Sun, Y. J., J. Rose, B. C. Wang, and C. D. Hsiao, "The structure of glutamine-binding protein complexed with glutamine at 1.94 a resolution: comparisons with other amino acid binding proteins," *J Mol Biol*, Vol. 278, pp. 219–229, Apr 1998.
32. Anson, L. C., P. E. Chen, D. J. Wyllie, D. Colquhoun, and R. Schoepfer, "Identification of amino acid residues of the nr2a subunit that control glutamate potency in recombinant nr1/nr2a nmda receptors," *J Neurosci*, Vol. 18, pp. 581–589, Jan 1998.

33. Lieberman, D. N., and I. Mody, "Regulation of nmda channel function by endogenous $ca(2+)$ -dependent phosphatase," *Nature*, Vol. 369, pp. 235–239, May 1994.
34. Wang, L. Y., M. W. Salter, and J. F. MacDonald, "Regulation of kainate receptors by camp-dependent protein kinase and phosphatases," *Science*, Vol. 253, pp. 1132–1135, Sep 1991.
35. Cooke, S. F., and T. V. Bliss, "Plasticity in the human central nervous system," *Brain*, Vol. 129, pp. 1659–1673, Jul 2006.
36. Richter, F., M. Hamann, and A. Richter, "Chronic rotenone treatment induces behavioral effects but no pathological signs of parkinsonism in mice," *J Neurosci Res*, Vol. 85, pp. 681–691, Feb 2007.
37. Walker, J. E., "The nadh:ubiquinone oxidoreductase (complex i) of respiratory chains," *Q Rev Biophys*, Vol. 25, pp. 253–324, Aug 1992.
38. Degli Esposti, M., "Inhibitors of nadh-ubiquinone reductase: an overview," *Biochim Biophys Acta*, Vol. 1364, pp. 222–235, May 1998.
39. Schuler, F., T. Yano, S. Di Bernardo, T. Yagi, V. Yankovskaya, T. P. Singer, and J. E. Casida, "Nadh-quinone oxidoreductase: Psst subunit couples electron transfer from iron-sulfur cluster n2 to quinone," *Proc Natl Acad Sci U S A*, Vol. 96, pp. 4149–4153, Mar 1999.
40. Sherer, T. B., R. Betarbet, C. M. Testa, B. B. Seo, J. R. Richardson, J. H. Kim, G. W. Miller, T. Yagi, A. Matsuno-Yagi, and J. T. Greenamyre, "Mechanism of toxicity in rotenone models of parkinson's disease," *J Neurosci*, Vol. 23, pp. 10756–10764, Nov 2003.
41. Sherer, T. B., R. Betarbet, A. K. Stout, S. Lund, M. Baptista, A. V. Panov, M. R. Cookson, and J. T. Greenamyre, "An in vitro model of parkinson's disease: linking mitochondrial impairment to altered alpha-synuclein metabolism and oxidative damage," *J Neurosci*, Vol. 22, pp. 7006–7015, Aug 2002.
42. Fiskum, G., A. Starkov, B. M. Polster, and C. Chinopoulos, "Mitochondrial mechanisms of neural cell death and neuroprotective interventions in parkinson's disease," *Ann N Y Acad Sci*, Vol. 991, pp. 111–119, Jun 2003.
43. Gao, H. M., J. S. Hong, W. Zhang, and B. Liu, "Distinct role for microglia in rotenone-induced degeneration of dopaminergic neurons," *J Neurosci*, Vol. 22, pp. 782–790, Feb 2002.
44. Uversky, V. N., J. Li, K. Bower, and A. L. Fink, "Synergistic effects of pesticides and metals on the fibrillation of alpha-synuclein: implications for parkinson's disease," *Neurotoxicology*, Vol. 23, pp. 527–536, Oct 2002.
45. Kweon, G. R., J. D. Marks, R. Krencik, E. H. Leung, P. T. Schumacker, K. Hyland, and U. J. Kang, "Distinct mechanisms of neurodegeneration induced by chronic complex i inhibition in dopaminergic and non-dopaminergic cells," *J Biol Chem*, Vol. 279, pp. 51783–51792, Dec 2004.
46. Uversky, V. N., "Neurotoxicant-induced animal models of parkinson's disease: understanding the role of rotenone, maneb and paraquat in neurodegeneration," *Cell Tissue Res*, Vol. 318, pp. 225–241, Oct 2004.

47. Wang, X. F., S. Li, A. P. Chou, and J. M. Bronstein, "Inhibitory effects of pesticides on proteasome activity: implication in parkinson's disease," *Neurobiol Dis*, Vol. 23, pp. 198–205, Jul 2006.
48. Bywood, P. T., and S. M. Johnson, "Mitochondrial complex inhibitors preferentially damage substantia nigra dopamine neurons in rat brain slices," *Exp Neurol*, Vol. 179, pp. 47–59, Jan 2003.
49. Hirsch, E. C., G. Höglinger, E. Rousset, T. Breidert, K. Parain, J. Feger, M. Ruberg, A. Prigent, C. Cohen-Salmon, and J. M. Launay, "Animal models of parkinson's disease in rodents induced by toxins: an update," *J Neural Transm Suppl*, no. 65, pp. 89–100, 2003.
50. Ahmadi, F. A., D. A. Linseman, T. N. Grammatopoulos, S. M. Jones, R. J. Bouchard, C. R. Freed, K. A. Heidenreich, and W. M. Zawada, "The pesticide rotenone induces caspase-3-mediated apoptosis in ventral mesencephalic dopaminergic neurons," *J Neurochem*, Vol. 87, pp. 914–921, Nov 2003.
51. CHANCE, B., G. R. WILLIAMS, and G. HOLLUNGER, "Inhibition of electron and energy transfer in mitochondria. iii. spectroscopic and respiratory effects of uncoupling agents," *J Biol Chem*, Vol. 238, pp. 439–444, Jan 1963.
52. Marshall, L. E., and R. H. Himes, "Rotenone inhibition of tubulin self-assembly," *Biochim Biophys Acta*, Vol. 543, pp. 590–594, Nov 1978.
53. Ren, Y., W. Liu, H. Jiang, Q. Jiang, and J. Feng, "Selective vulnerability of dopaminergic neurons to microtubule depolymerization," *J Biol Chem*, Vol. 280, pp. 34105–34112, Oct 2005.
54. Jiang, Q., Z. Yan, and J. Feng, "Activation of group iii metabotropic glutamate receptors attenuates rotenone toxicity on dopaminergic neurons through a microtubule-dependent mechanism," *J Neurosci*, Vol. 26, pp. 4318–4328, Apr 2006.
55. Bonsi, P., P. Calabresi, C. De Persis, M. Papa, D. Centonze, G. Bernardi, and A. Pisani, "Early ionic and membrane potential changes caused by the pesticide rotenone in striatal cholinergic interneurons," *Exp Neurol*, Vol. 185, pp. 169–181, Jan 2004.
56. Samantaray, S., V. H. Knaryan, M. K. Guyton, D. D. Matzelle, S. K. Ray, and N. L. Banik, "The parkinsonian neurotoxin rotenone activates calpain and caspase-3 leading to motoneuron degeneration in spinal cord of lewis rats," *Neuroscience*, Vol. 146, pp. 741–755, May 2007.
57. Wang, G., C. Qi, G. H. Fan, H. Y. Zhou, and S. D. Chen, "Pacap protects neuronal differentiated pc12 cells against the neurotoxicity induced by a mitochondrial complex i inhibitor, rotenone," *FEBS Lett*, Vol. 579, pp. 4005–4011, Jul 2005.
58. Ren, Y., and J. Feng, "Rotenone selectively kills serotonergic neurons through a microtubule-dependent mechanism," *J Neurochem*, Vol. 103, pp. 303–311, Oct 2007.
59. Choi, W. S., S. E. Kruse, R. D. Palmiter, and Z. Xia, "Mitochondrial complex i inhibition is not required for dopaminergic neuron death induced by rotenone, mpp+, or paraquat," *Proc Natl Acad Sci U S A*, Vol. 105, pp. 15136–15141, Sep 2008.
60. Ren, Y., J. Zhao, and J. Feng, "Parkin binds to alpha/beta tubulin and increases their ubiquitination and degradation," *J Neurosci*, Vol. 23, pp. 3316–3324, Apr 2003.

61. Jiang, Q., Z. Yan, and J. Feng, "Neurotrophic factors stabilize microtubules and protect against rotenone toxicity on dopaminergic neurons," *J Biol Chem*, Vol. 281, pp. 29391–29400, Sep 2006.
62. Wu, Y. N., and S. W. Johnson, "Rotenone potentiates nmda currents in substantia nigra dopamine neurons," *Neurosci Lett*, Vol. 421, pp. 96–100, Jun 2007.
63. Wu, Y. N., and S. W. Johnson, "Rotenone reduces mg²⁺-dependent block of nmda currents in substantia nigra dopamine neurons," *Neurotoxicology*, Vol. 30, pp. 320–325, Mar 2009.
64. Freestone, P. S., K. K. Chung, E. Guatteo, N. B. Mercuri, L. F. Nicholson, and J. Lipski, "Acute action of rotenone on nigral dopaminergic neurons— involvement of reactive oxygen species and disruption of ca²⁺ homeostasis," *Eur J Neurosci*, Vol. 30, pp. 1849–1859, Nov 2009.
65. Costa, C., V. Belcastro, A. Tozzi, M. Di Filippo, M. Tantucci, S. Siliquini, A. Autuori, B. Picconi, M. G. Spillantini, E. Fedele, A. Pittaluga, M. Raiteri, and P. Calabresi, "Electrophysiology and pharmacology of striatal neuronal dysfunction induced by mitochondrial complex i inhibition," *J Neurosci*, Vol. 28, pp. 8040–8052, Aug 2008.