

SOLID WASTE MANAGEMENT CASE STUDIES IN ISTANBUL - KEMERBURGAZ  
AND BURSA - GECIT

by

Uraz Polat

B.S., in C.E., Boğaziçi University, 2007

Submitted to the Institute for Graduate Studies in  
Science and Engineering in partial fulfillment of  
the requirements for the degree of  
Master of Science

Graduate Program in Civil Engineering  
Boğaziçi University

2010

## ACKNOWLEDGEMENTS

First, I would like to express my sincere gratitude to my thesis supervisor, Assoc.Prof. Atilla Akkoyunlu for his guidance, support and encouragement throughout the preparation of this thesis. Without his sympathy, patience and guidance, the accomplishment would be impossible.

I extend my sincere thanks to Prof. Ferruh Ertürk and Prof. Orhan Yenigün, for their kind and supportive attitude to me and showing high interests and valuable advices to my thesis.

I want to convey special thanks to İstaç Aş., Ortadoğu Enerji and Municipality of Metropolis Bursa, Environmental Protection and Control Agency (EPCA) for sharing their experience and documents devotedly.

Lastly, I would like to thank my father, mother and brother for their endless support.

## **ABSTRACT**

### **SOLID WASTE MANAGEMENT CASE STUDIES IN ISTANBUL - KEMERBURGAZ AND BURSA - GECIT**

The limited resources have been exhausting because of developed technology, growth of population, production and consumption gain all over the world. Nevertheless solid wastes, which human being caused, are one of the main factors in environmental problem.

The large and increasing amounts of municipal solid wastes generated each year in several industrialized countries, have raised concerns about the economic viability and environmental acceptability of the current waste disposal methodologies. There are various options available to convert solid waste to energy. Mainly, the following types of technologies are available: sanitary landfill, incineration, gasification and anaerobic digestion. Sanitary landfill is the scientific dumping of municipal solid waste and landfill gas could be used for generating power.

In this study, methods of solid waste disposed, and energy potential of the solid wastes were examined by giving Istanbul-Kemerburgaz application. In the first section of the thesis, the importance, aim and extent of the study was explained. In the second section definitions and evaluations about solid wastes were given. In the other sections integrated waste management, land filling and land fill gas as an energy resource were explained respectively. Istanbul-Kemerburgaz Project about waste to energy application was investigated in the seventh section of the thesis. According to the literature and Istanbul Project, a projection of potential of Bursa Gecit Sanitary landfill has been done in the eighth section. And in the last section results were evaluated.

The main purpose of this study is to investigate the waste to energy implementation of Istanbul-Kemberburgaz Facility and apply the results to Bursa-Geçit Sanitary Landfill to estimate its gas and electricity potential. And to illustrate the progress on the management of municipal solid wastes to the prospective municipalities around, during the harmonization studies for the membership of Turkey to European Union.

## ÖZET

### **KATI ATIK YÖNETİM ÇALIŞMALARINA İKİ ÖRNEK: İSTANBUL - KEMERBURGAZ VE BURSA - GEÇİT**

Sınırlı doğal kaynaklar; gelişen teknoloji, nüfus artışı, üretim ve tüketim nedeniyle her geçen gün tükenmektedir. Bununla birlikte katı atıklar en önemli çevre problemlerinden biridir.

Günümüzde gelişmiş ülkelerinin en büyük sorunlarından biri hızla artmakta olan katı atıklardır. Bu sorun atıkların bertarafında kullanılan teknolojilerin ekonomik ve çevre dostu olması ile ilgili endişeleri arttırmaktadır. Atıkları enerjiye dönüştürmek için çeşitli teknolojiler mevcuttur. Temel olarak bu teknolojilerin başlıcaları düzenli depolama, yakma, gazlaştırma ve anaerobik çürütmedir. Düzenli depolama atıkların mühendislik esaslarına göre depolanmasıdır. Depo gazı enerji üretiminde kullanılabilir.

Bu çalışmada katı atık incelenmiş ve İstanbul Kemerburgaz örneği ile enerji potansiyeli araştırılmıştır. Tezin ilk bölümünde tezin amaç ve içeriğinden bahsedilmiştir. İkinci bölümde katı atığın tanımı ve katı atıkla ilgili çeşitli hesaplamalar verilmiştir. İlerleyen bölümlerde; katı atık yönetimi, depo gazı ve depo gazı kaynaklı enerji üretim teknikleri sırasıyla incelenmiştir. İstanbul-Kemerburgaz düzenli depolama ve elektrik üretimi projesi etrafında yedinci bölümde incelenmiş buradan elde edilen sonuçların literatür bilgisi ile harmanlanıp Bursa-Geçit düzenli depolama sahasına uygulanabilirliği ise bir sonraki bölümde işlenmiştir. Sonuç bölümünde ise elde edilen değerler irdelenmiştir.

Bu çalışmanın ana amacı İstanbul-Kemerburgaz enerji üretim tesisini inceleyerek buradan elde edilen sonuçları Bursa-Geçit düzenli depolama sahasına uygulayarak buranın depo gazı ve elektrik potansiyeli hakkında bir tahminde bulunmaktır. Bu proje Avrupa

Birliđi'ne üye ařamasında olduđumuz řu dđnemde evre belediyelere rnek bir proje olma niteliđini amalamaktadır.

## TABLE OF CONTENTS

ACKNOWLEDGEMENTS.....	iii
ABSTRACT.....	iv
ÖZET.....	vi
LIST OF FIGURES.....	xiii
LIST OF TABLES .....	xvii
LIST OF SYMBOLS / ABBREVIATIONS .....	xix
1. INTRODUCTION .....	1
2. INTRODUCTION TO THE SOLID WASTE .....	2
2.1. Definition of Solid Waste .....	2
2.2. Classification of Solid Waste .....	2
2.3. Types of Municipal Solid Waste .....	3
2.4. Physical, Chemical and Biological Properties of Municipal Solid Waste .....	4
2.4.1. Physical Properties of MSW .....	4
2.4.2. Chemical Properties of MSW .....	10
2.4.3. Biological Properties of MSW .....	11
3. INTEGRATED WASTE MANAGEMENT .....	13
3.1. Definition of Solid Waste .....	15
3.1.1. Landfills .....	15
3.1.2. Large Open Dumps .....	16
4. LAND FILLING .....	17
4.1. Introduction .....	17
4.2. Landfilling Objectives .....	17
4.3. Landfill Site Design and Operation .....	18

4.4. Landfill Leachate .....	22
4.5. Landfill Gases .....	24
4.5.1. Composition and Characteristics of Landfill Gas .....	25
4.5.2. Principal Landfill Gas Constituents .....	25
4.5.3. Trace Landfill Gas Constituents .....	27
4.5.4. Generation of the Principal Landfill Gases .....	29
4.5.5. Factors Affecting Landfill Gas Generation .....	32
4.5.6. Duration of Phases .....	36
4.5.7. Variation in Gas Production with Time .....	39
4.6. Environmental Monitoring Systems .....	41
4.6.1. Water .....	43
4.6.2. Air .....	43
4.6.3. Soil .....	43
4.7. Control of Landfill Gases .....	43
4.7.1. Passive Control of Landfill Gases .....	44
4.7.1.1. Pressure Relief Vents/Flares in Landfill Cover .....	44
4.7.1.2. Perimeter Interceptor Trenches .....	46
4.7.1.3. Perimeter Barrier Trench or Slurry Wall .....	47
4.7.1.4. Impermeable Barriers within Landfills .....	47
4.7.2. Active Control of Landfill Gas with Perimeter Facilities .....	49
4.7.2.1. Perimeter Gas Extraction and Odor Control Wells .....	49
4.7.2.2. Perimeter Gas Extraction Trenches .....	52
4.7.2.3. Perimeter Air Injection Wells (Air Curtain System) .....	52
4.7.3. Active Control of Landfill Gas with Vertical and Horizontal Gas Extraction Wells .....	52

4.7.3.1. Vertical Gas Extraction Wells .....	53
4.7.3.2. Horizontal Gas Extraction Wells .....	55
4.8. Current Landfilling Activity .....	56
5. USE FOR ENERGY .....	57
5.1. "Large" Landfills and Open Dumps .....	59
5.1.1. Obtain Individual Landfill Information .....	59
5.1.2. Estimate Average Landfill Size .....	60
5.1.3. Estimate the Number of People Per Landfill or Open Dump .....	63
5.1.4. Waste Characteristics .....	64
5.2. Initial Appraisal Results .....	65
5.3. Potential Gas Production .....	67
5.3.1. Method 1: Test Wells .....	68
5.3.2. Method 2: Rough Approximation .....	68
5.3.3. Method 3: Model Estimates .....	69
6. GAS RECOVERY AND UTILIZATION .....	72
6.1. Gas Recovery Technologies .....	72
6.1.1. Gas Collection Wells .....	72
6.1.2. Blower .....	73
6.1.3. Flare .....	74
6.2. Gas Utilization Technologies .....	75
6.2.1. Local Gas Use .....	75
6.2.2. Electricity Generation .....	76
6.2.3. Pipeline Injection .....	78
7. ISTANBUL-KEMERBURGAZ LANDFILL GAS TO ENERGY PROJECT .....	81
7.1. Introduction .....	81

7.2. Metropolis Istanbul .....	81
7.2.1. Geography .....	81
7.2.2. Climate .....	82
7.2.3. Demography .....	83
7.3. Istanbul Kemerburgaz Sanitary Landfill .....	83
7.3.1. Design Properties .....	85
7.3.2. Composition of Waste .....	88
7.3.3. Leachate Treatment Plant .....	89
7.3.3.1. Leachate Treatment Processes .....	91
7.3.4. Compost Facility .....	96
7.3.5. General Properties of Energy Recovery Plant .....	99
7.3.6. Main Elements of Landfill Gas to Energy Plant .....	100
7.3.6.1. Gas Collection System .....	102
7.3.6.2. Gas Conditioning System .....	103
7.3.6.3. Electricity Generation and Distribution System .....	103
7.4. Economic Valuation of The Project .....	105
7.4.1. Gas and Electricity Profile .....	105
7.4.2. Investment .....	109
7.4.3. Carbon Market .....	111
7.4.4. Carbon Emission Potential .....	113
7.4.5. Revenue .....	113
8. CASE STUDY: METROPOLIS BURSA .....	115
8.1. General Information about Bursa .....	115
8.2. Integrated Waste Management in Bursa .....	116
8.3. Bursa Municipal Sanitary Landfill .....	117

8.3.1. Design Properties of Geçit Sanitary Landfill .....	119
8.3.2. Contents of Geçit Solid Waste .....	124
8.4. Solid Waste Capacity of Geçit Sanitary Landfill .....	125
8.5. Gas and Electricity Potential of Geçit Sanitary Landfill .....	127
8.5.1. Model Estimates .....	128
8.5.1.1. Model of LandGEM (EPA).....	128
8.5.1.2. First Order Model.....	130
8.5.1.3. Tabasaran/Rettenberger .....	130
8.5.2. Estimated Gas Potential of Geçit .....	133
8.5.3. Electricity Potential of Landfill Gas in Geçit .....	134
8.5.4. Carbon Emission Potential of Landfill Gas in Geçit .....	136
8.5.5. Economic Valuation .....	137
9. CONCLUSIONS .....	139
REFERENCES.....	141

## LIST OF FIGURES

Figure 2.1.	Typical sizes of individual components comprising residential and Commercial MSW.....	7
Figure 2.2.	Percentage of total mass of residential and commercial MSW as a function of mesh size.....	8
Figure 2.3.	Typical size distribution of the components found in residential MSW ...	8
Figure 3.1.	Integrated Solid Waste Management Flow Diagram .....	14
Figure 4.1.	Typical landfill site .....	19
Figure 4.2.	A schematic of a typical MSW landfill .....	21
Figure 4.3.	Estimated times when compounds in leachate become harmless to the environment.....	22
Figure 4.4.	Simplified plan of a landfill with a double liner system .....	23
Figure 4.5.	Landfill liner systems required for materials containing different levels of Total Organic Carbon .....	24
Figure 4.6.	Generalized phases in the generation of landfill gases .....	29
Figure 4.7.	Temperature variability as a function of time at various depths .....	35
Figure 4.8.	Graphical representation of gas production over a five year period from rapidly and slowly decomposable organic materials placed in a landfill ..	40
Figure 4.9.	The composition of landfill gas over time .....	41
Figure 4.10.	Typical gas vents used in the surface of a landfill for the passive control of landfill gas .....	45
Figure 4.11.	Typical candlestick type waste gas burner used to flare landfill gas from a well vent or several interconnected well vents .....	46
Figure 4.12.	Passive facilities used for the control of landfill gas .....	48

Figure 4.13.	Active facilities used for subsurface control of landfill gas migration.....	50
Figure 4.14.	Representative detail of a landfill gas extraction well .....	51
Figure 4.15.	Landfill gas recovery system using vertical wells .....	53
Figure 4.16.	Equilateral triangular distribution for vertical gas extraction wells .....	54
Figure 4.17.	Details of horizontal gas extraction trench .....	55
Figure 4.18.	Percentage of MSW landfilled in OECD countries .....	56
Figure 6.1.	Typical Gas Collection Well .....	73
Figure 6.2.	Typical Open Flare .....	74
Figure 7.1.	Annual solid waste amounts collected in Kemerburgaz Sanitary Landfill.....	84
Figure 7.2.	Cumulative solid waste amount collected in Kemerburgaz Sanitary Landfill .....	84
Figure 7.3.	Kemerburgaz Sanitary Landfill .....	85
Figure 7.4.	Cross section of a typical Platform .....	86
Figure 7.5.	Impermeable geomembrane spread under landfill .....	87
Figure 7.6.	Kemerburgaz Sanitary Landfill .....	88
Figure 7.7.	Kemerburgaz Leachate Treatment Plant .....	90
Figure 7.8.	Sedimentation pool .....	91
Figure 7.9.	Ammonium evaporation .....	92
Figure 7.10.	Heat Exchanger .....	93
Figure 7.11.	Cross flow tube membranes .....	94
Figure 7.12.	Nano filtration capillary membranes .....	95
Figure 7.13.	Kemerburgaz Compost Facility .....	96
Figure 7.14.	Kemerburgaz Compost Facility .....	97
Figure 7.15.	Compost produced in Kemerburgaz Compost Facility .....	98

Figure 7.16.	Schema of Landfill Gas to Energy Power Plant .....	101
Figure 7.17.	Genplan of Gas Collection Wells of Kemerburgaz Sanitary Landfill with Effective Diameters .....	102
Figure 7.18.	Typical conditioning system with flare .....	103
Figure 7.19.	Typical Electricity Generation System with Gas Engine .....	104
Figure 7.20.	Schema of Landfill Gas to Energy Power Plant .....	104
Figure 7.21.	Average temperature values of LFG in Kemerburgaz .....	105
Figure 7.22.	Average absorption pressure values through 2009 .....	106
Figure 7.23.	The amount of methane obtaining from field per hour .....	107
Figure 7.24.	Generated Electricity in Kemerburgaz Gas to Energy Facility .....	108
Figure 7.25.	Total Generated Electricity through 2009 in Kemerburgaz Gas to Energy Facility .....	109
Figure 7.26.	The Prospect of Renewable Energy in Turkey .....	110
Figure 7.27.	Carbon certifies distribution in the world .....	111
Figure 7.28.	Carbon certifies distribution in Turkey .....	112
Figure 7.29.	The variation of carbon purchase prices in Voluntary Carbon Market ...	112
Figure 8.1.	The average low and high temperature values of Bursa .....	115
Figure 8.2.	Bursa Medical Waste Sterilization Facility .....	117
Figure 8.3.	Sterilization tanks .....	117
Figure 8.4.	Municipal Sanitary Landfill in Geçit, Bursa .....	118
Figure 8.5.	Landfill valleys cross section in Geçit, Bursa .....	119
Figure 8.6.	First step Valley T .....	120
Figure 8.7.	Second Stage (MainValley) .....	121
Figure 8.8.	Third Stage (MainValley) .....	122
Figure 8.9.	Geçit Sanitary Landfill .....	125

Figure 8.10.	Annual collected amount of waste since 1995 .....	126
Figure 8.11.	Cumulative collected amount of waste since 1995 .....	126
Figure 8.12.	Monthly averages .....	127
Figure 8.13.	Landfilled solid waste projection of forthcoming fifteen years .....	128
Figure 8.14a.	The estimated LFG comparison in Kemerburgaz between three gas models.....	132
Figure 8.14b.	The estimated LFG comparison in Geçit between three gas models .....	132
Figure 8.15.	Gas potential projection of Geçit Sanitary Landfill .....	134
Figure 8.16.	Electricity potential projection of Geçit Sanitary Landfill .....	136
Figure 8.17.	Estimated carbon emission reduction amounts in consequence of energy production from solid waste instead of fossil fuel .....	137

## LIST OF TABLES

Table 2.1.	Categories of solid waste .....	3
Table 2.2.	Typical specific weight and moisture content data for residential, commercial, industrial, and agricultural wastes .....	5
Table 2.3.	Typical data on the ultimate analysis of the combustible components in residential MSW .....	11
Table 4.1.	Landfilling: key considerations .....	18
Table 4.2.	Typical constituents found in MSW landfill gas .....	26
Table 4.3.	Molecular weight, density, and specific weight of gases found in sanitary landfill at standard conditions. ....	27
Table 4.4.	Typical concentrations of trace compounds found in landfill gas at 66 MSW landfills .....	28
Table 4.5.	Refuse Moisture Content .....	33
Table 4.6.	Percentage distribution of landfill gases observed during the first 48 months after the closure of landfill cell .....	37
Table 4.7.	Rapidly and slowly biodegradable organic constituents in MSW .....	38
Table 4.8.	Environmental monitoring facilities that are installed during landfill construction and operations and used after landfill closure .....	42
Table 5.1.	Are There Uses for the Energy Recovered? .....	58
Table 5.2.	Waste Disposal and Waste Generation.....	62
Table 5.3.	Initial Appraisal Results Checklist .....	67
Table 6.1.	General Comparison of Gas Turbine and Internal Combustion Engines .	77
Table 6.2.	Summary of Technical Feasibility of Utilization Options for LFG.....	80

Table 7.1.	Climate data for Istanbul .....	82
Table 7.2.	Composition of Kemerburgaz Sanitary Landfill solid waste .....	89
Table 7.3.	Raw leachate properties in Odayeri, Kemerburgaz .....	90
Table 7.4.	Discharge standards in Odayeri, Kemerburgaz .....	95
Table 7.5.	Heavy Metal Values .....	98
Table 7.6.	Total Annual Income .....	114
Table 7.7.	Total Annual Expenditure .....	114
Table 8.1.	Properties of Valley X .....	119
Table 8.2.	Drainage cross section of Valley X .....	120
Table 8.3.	Properties of Valley T .....	120
Table 8.4.	Drainage cross section of Valley T .....	121
Table 8.5.	Properties of Second Stage - Main Valley .....	121
Table 8.6.	Drainage cross section of Main Valley .....	122
Table 8.7.	Properties of Third Stage - Main Valley .....	122
Table 8.8.	Drainage cross section of Main Valley .....	123
Table 8.9.	Disposed solid waste amounts in Sanitary Landfill since 1995 .....	123
Table 8.10.	The components of solid waste according to three different income levels in Bursa .....	124
Table 8.11.	Potential Methane Generation Capacity ( $L_0$ ) and Methane Generation Constants .....	133
Table 8.12.	2009 Electricity Consumption Values of Bursa .....	135
Table 8.13.	Total Income Expectation in 2010.....	138
Table 8.14.	Total Expenditure Expectation in 2010 .....	138

## LIST OF SYMBOLS / ABBREVIATIONS

$A$	Amount of waste in place
$C$	Amount of organic carbon in waste
$c$	Time since landfill closure
$d$	Average size of pores
$G_t$	LFG gas production at a given time
$G_{org}$	Organic carbon content
$GWh$	Gigawatt*hour
$H$	Height
$Hp$	Horsepower
$K$	Coefficient of permeability
$k$	Intrinsic permeability
$k_d$	Degradation rate constant
$KW$	Kilowatt
$KV$	Kilovolt
$L$	Length
$L_0$	Total methane generation potential of the waste
$M$	Moisture content
$MW$	Megawatt
$Sc$	Size of component
$R$	Average annual waste acceptance rate during active life
$t$	Time since landfill opened
$T$	Temperature
$W$	Width
$w$	Initial weight of sample as delivered

$\alpha_t$	LFG gas production at a given time
$\gamma$	Specific weight of water
$\mu$	Dynamic viscosity of water
$\zeta$	Dissimilation factor
ACR	American Carbon Registry
BOD	Biochemical Oxygen Demand
CAR	Climate Action Reserve
CER	Certified Emission Reduction
COD	Chemical Oxygen Demand
DSI	General Directorate of State Hydraulic Works
EPCA	Environmental Protection and Control Agency
EPDK	Energy Market Regulatory Authority
EU	European Union
EUR	Euro
GE	General Electric
Gold	Gold Standard
HDPE	High Density Poly Ethylene
IC	Internal Combustion
İSTAÇ	İstanbul Çevre Yönetimi Sanayi ve Ticaret A.Ş
LFG	Landfill Gas
MSW	Municipal Solid Waste
OECD	Organization for Economic Co-operation and Development
PE	Polyethylene
PVC	Polyvinyl Chloride
SSM	Suspended Solid Matter
TEİAŞ	Turkish Electricity Transmission Company

TKB	Turkish Development Bank
TKN	Total Kjeldahl Nitrogen
TOC	Total Organic Carbon
TSKB	Turkish Industry and Development Bank
USD	United State Dollar
USEPA	United State Environmental Protection Agency
VCS	Voluntary Carbon Standard
VER	Verified Emission Reduction
VOC	Volatile Organic Compound

## 1. INTRODUCTION

Disposal of waste to landfill is an inevitable component of every solid waste management system. Even if facilities are provided for recovery and recycle materials, there will be always need land disposal for residual waste. In some countries, cheap disposal methods are preferable and that is why the number of open dumps is increasing.

Solid waste landfills are heterogeneous environment. Once municipal solid waste is placed in landfill, a complex sequence of biologically, chemically, and physically mediated events occurs that results in gaseous end products during the predominately anaerobic stabilization of solid waste organic fractions.

A number of techniques can be utilized to obtain estimates of gas production. One of these techniques is the using of mathematical models. These models predict the Landfill Gas (LFG) generation as a function of number of variables. In general, models found are used for sanitary landfills.

In Turkey there are a few sanitary landfill applications. Most proper ones are in Istanbul and Bursa metropolitans.

According to census of population in 2009, 12.915.158 people live in Istanbul. By the day Istanbul's population has been increasing because of migration from the country side. It was calculated that solid wastes amount were 1.751.065 tons in 1996 and 5.047.067 tons in 2006. At the present according to ISTAC Inc. records it has extremely increased and approached to 47 million tons, which was collected from Anatolian side, is 32 per cent and in European side is 68 per cent.

In another metropolis of Turkey, Bursa; population is 2,550,645 in 2009. It is Turkey's fourth largest city, as well as one of the most industrialized and culturally charged metropolitan centers in the country. At the present according to Municipality of Bursa Metropolitan 6.739.483 tons of waste collected and landfilled. Estimations gives that 22.200.000 tons of solid waste landfilled up to the year 2025.

## **2. INTRODUCTION TO THE SOLID WASTE**

### **2.1. Definition of Solid Waste**

Solid waste comprise all the wastes arising from human and animal activities that are normally solid and that are discarded as useless or unwanted. The term solid waste represents all-inclusive, encompassing the heterogeneous mass of throwaways from the urban community as well as the more homogeneous accumulation of agricultural, industrial and mineral wastes (Tchobanoglous et al., 1993).

Useless, cannot be used, not wanted; these are some of the dictionary meanings of waste. Generally readers are carried away by such concepts, as if greater portion of solid waste means municipal solid waste (MSW).

### **2.2. Classification of Solid Waste**

Waste can be classified by a multitude of schemes: by physical state (solid, liquid, gaseous), and then within solid waste by: original use (packaging waste, food waste, etc.), by material (glass, paper, etc.), by physical properties (combustible, compostable, recyclable), by origin (domestic, commercial, agricultural, industrial, etc.) or by safety level (hazardous, nonhazardous). Household and commercial waste often referred to together as Municipal Solid Waste (MSW). The most commonly used categories are listed in Table 2.1 (McDougall et al., 2001).

Table 2.1. Categories of solid waste (McDougall et al., 2001)

Solid waste category	Description
Agricultural	Waste arising from agricultural practices, especially livestock production. Often either used (applied to land) or treated <i>in situ</i> .
Mining and quarrying	Mainly inert mineral wastes, from coal mining and mineral extraction industries.
Dredging spoils	Organic and mineral wastes from dredging operations.
Construction and demolition	Building waste, mainly inert mineral or wood wastes.
Industrial	Solid waste from industrial processes. Sometimes will include energy production industries.
Energy production	Solid waste from the energy production industries, including fly ash from coal burning.
Sewage sludge	Organic solid waste, disposed of by burning, dumping at sea (soon to cease in the EU), application to land or composting. May result from industrial or domestic waste water treatment.
Hazardous/ Special waste	Solid waste, which can contain substances that are dangerous to life, is termed 'Special waste' in UK, or 'Hazardous waste' in EU directives.
Commercial	Solid waste from offices, shops, restaurants, etc. often included in MSW.
Municipal Solid Waste (MSW)	Defined as the solid waste collected and controlled by the local authority or municipality and typically consists of household waste, commercial waste and institutional waste.

### 2.3. Types of Municipal Solid Waste

Municipal solid waste (MSW) mainly consists of:

(i) Food wastes, commonly called garbage, are prone to decompose. They originate from food products of animal and vegetable origin, arising out of preparation, processing, handling, catering, and eating.

(ii) Rubbish is combustible and non-combustible rejected materials other than those mentioned above. The combustible portion (trash) consists of paper, cardboard, textiles, plastics, rubber, etc. The non-combustible portion consists of glass, ceramics, metals, etc.

(iii) Ashes and cinders originate mainly from coal, firewood, and burnt residues of other combustible materials.

(iv) Construction and demolition wastes include wide varieties of materials, mostly non-combustible in nature. Civil works of construction, remodelling, repair works and demolition of building structures and others that include broken pieces of bricks, stones, plasters, dirt, sand, wooden articles, metal pieces, electrical parts, etc.

(v) Water treatment plant wastes are obtained from the water treatment plants in solid or semisolid form, such as resins, organic waste, inorganic waste, etc.

(vi) Special wastes are uncommon materials accumulated from unpredictable and infrequent sources, i.e., abandoned vehicles, dead animals, limbs, blood, etc. from hospitals; and that found from street sweepings (Nag and Vizayakumar, 2005).

## **2.4 Physical, Chemical and Biological Properties of Municipal Solid Waste**

### **2.4.1. Physical Properties of MSW**

Important physical characteristics of MSW include specific weight, moisture content, particle size and size distribution, field capacity, and compacted waste porosity.

- **Specific Weight**

Specific weight is defined as the weight of a material per unit volume (e.g., lb/ft<sup>3</sup>, lb/yd<sup>3</sup>). Because the specific weight of MSW is often reported as loose, as found in containers, uncompacted/ compacted, and the like, the basis used for the reported values should always be noted. Specific weight data are often needed to assess the total mass and

volume of waste that must be managed. Unfortunately, there is little or no uniformity in the way solid waste specific weights have been reported in the literature. Frequently, no distinction has been made between uncompacted or compacted specific weights. Typical specific weights for various wastes as found in containers, compacted, or uncompacted are reported in Table 2.2

Table 2.2. Typical specific weight and moisture content data for residential, commercial, industrial, and agricultural wastes (Tchobanoglous et al., 1993)

Type of waste	Specific weight, lb/yd <sup>3</sup>		Moisture content, % by weight	
	Range	Typical	Range	Typical
Residential (uncompacted)				
Food wastes (mixed)	220-810	490	50-80	70
Paper	70-220	150	4-10	6
Cardboard	70-135	85	4-8	5
Plastics	70-220	110	1-4	2
Textiles	70-170	110	6-15	10
Rubber	170-340	220	1-4	2
Leather	170-440	270	8-12	10
Yard wastes	100-380	170	30-80	60
Wood	220-540	400	15-40	20
Glass	270-810	330	1-4	2
Tin cans	85-270	150	2-4	3
Aluminum	110-405	270	2-4	2
Other metals	220-1940	540	2-4	3
Dirt, ashes, etc.	540-1685	810	6-12	8
Ashes	1095-1400	1255	6-12	6
Rubbish	150-305	220	5-20	15
Residential yard wastes				
Leaves (loose and dry)	50-250	100	20-40	30
Green grass (loose and moist)	350-500	400	40-80	60
Green grass (wet and compacted)	1000-1400	1000	50-90	80
Yard waste (shredded)	450-600	500	20-70	50
Yard waste (composted)	450-650	550	40-60	50
Municipal				
In compactor truck	300-760	500	15-40	20
In landfill				
Normally compacted	610-840	760	15-40	25
Well compacted	995-1250	1010 *»	15-40	25
Commercial				
Food wastes (wet)	800-1600	910	50-80	70
Appliances	250-340	305	0-2	1
Wooden crates	185-270	185	10-30	20
Tree trimmings	170-305	250	20-80	5
Rubbish (combustible)	85-305	200	10-30	15
Rubbish (noncombustible)	305-610	505	5-15	10

Rubbish (mixed)	235-305	270	10-25	15
Construction and demolition				
Mixed demolition (noncombustible)	1685-2695	2395	2-10	4
Mixed demolition (combustible)	505-675	605	4-15	8
Mixed construction (combustible)	305-605	440	4-15	8
Broken concrete	2020-3035	2595	0-5	-
Industrial				
Chemical sludges (wet)	1350-1855	1685	75-99	80
Fly ash	1180-1515	1350	2-10	4
Leather scraps	170-420	270	6-15	10
Metal scrap (heavy)	2530-3370	3000	0-5	—
Metal scrap (light)	840-1515	1245	0-5	—
Metal scrap (mixed)	1180-2530	1515	0-5	—
Oils, tars, asphalts	1350-1685	1600	0-5	2
Sawdust	170-590	490	10-40	20
Textile wastes	170-370	305	6-15	10
Agricultural				
Agricultural (mixed)	675-1265	945	40-80	50
Dead animals	340-840	605	—	—
Fruit wastes (mixed)	420-1265	605	60-90	75
Manure (wet)	1515-1770	1685	75-96	94
Vegetable wastes (mixed)	340-1180	605	60-90	75

- **Moisture Content**

The moisture content of solid wastes usually is expressed in one of two ways. In the wet-weight method of measurement, the moisture in a sample is expressed as a percentage of the wet weight of the material; in the dry-weight method, it is expressed as a percentage of the dry weight of the material. The wet-weight method is used most commonly in the field of solid waste management. In equation form, the wet-weight moisture content is expressed as follows (Tchobanoglous et al., 1993):

$$M = [(w-d)/w] * 100 \quad (2.1)$$

where  $M$  = moisture content, %

$w$  = initial weight of sample as delivered, lb (kg)

$d$  = weight of sample after drying at 105°C, lb (kg)

- **Particle Size and Size Distribution**

The size and size distribution of the component materials in solid wastes are an important consideration in the recovery of materials, especially with mechanical means such as trommel screens and magnetic separators. The size of a waste component may be defined by one or more of the following measures (Tchobanoglous et al., 1993):

$$S_c = l \quad (2.2)$$

$$S_c = (l+w)/2 \quad (2.3)$$

$$S_c = (l+w+h)/3 \quad (2.4)$$

$$S_c = (l*w)^{1/2} \quad (2.5)$$

$$S_c = (l*w*h)^{1/3} \quad (2.6)$$

where  $S_c$  = size of component, in (mm)  
 $l$  = length, in (mm)  
 $w$  = width, in (mm)  
 $h$  = height, in (mm)

A general indication of the particle size distribution (by longest dimension and ability to pass a sieve) may be obtained from the data presented in Figs. 2.1 and 2.2. Typical data on the size distribution of the individual components in MSW are presented in Fig. 2.3.

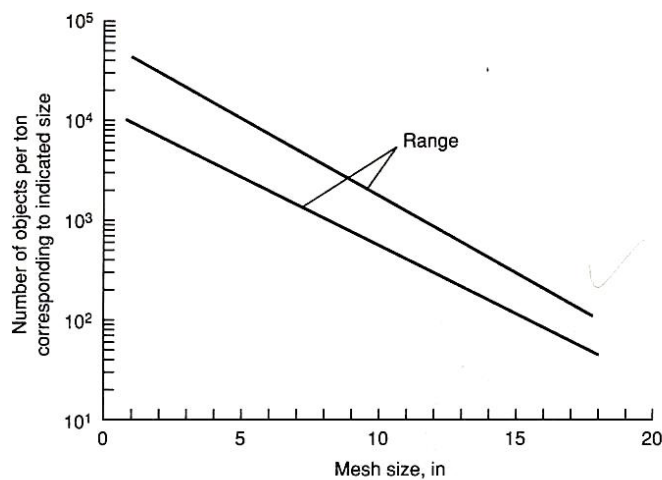

Figure 2.1. Typical sizes of individual components comprising residential and commercial MSW (Tchobanoglous et al., 1993)

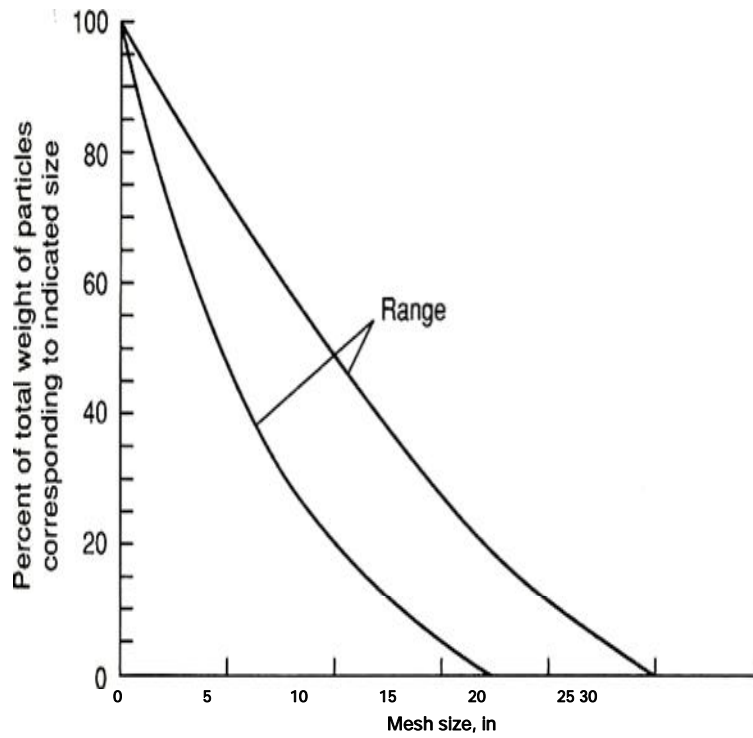

Figure 2.2. Percentage of total mass of residential and commercial MSW as a function of mesh size (Tchobanoglous et al., 1993)

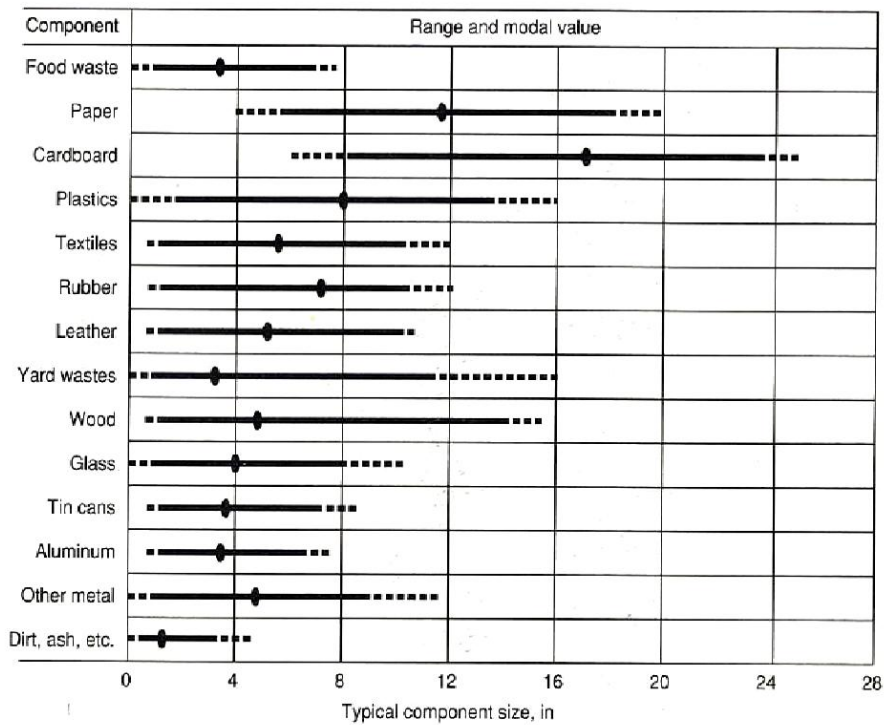

Figure 2.3. Typical size distribution of the components found in residential MSW (Tchobanoglous et al., 1993)

Because there are significant differences among the various measures on size, individual measurements should be made on the waste in question using a measure of size that will provide the information needed for the specific application.

- **Field Capacity**

The field capacity of solid waste is the total amount of moisture that can be retained in a waste sample subject to the downward pull of gravity. The field capacity of waste materials is of critical importance in determining the formation of leachate in landfills. Water in excess of the field capacity will be released as leachate. The field capacity varies with the degree of applied pressure and the state of decomposition of the waste. A field capacity of 30 per cent by volume corresponds to 30 in/100 in. The field capacity of uncompacted commingled wastes from residential and commercial sources is in the range of 50 to 60 per cent (Tchobanoglous et al., 1993).

- **Permeability of Compacted Waste**

The hydraulic conductivity of compacted wastes is an important physical property that, to a large extent, governs the movement of liquids and gases in a landfill. The coefficient of permeability is normally written as (Tchobanoglous et al., 1993):

$$K = Cd^2 * (\gamma/\mu) = k * (\gamma/\mu) \quad (2.6)$$

where

- $K$  = coefficient of permeability ( $m^2$ )
- $C$  = dimensionless constant or shape factor
- $d$  = average size of pores (m)
- $\gamma$  = specific weight of water ( $kg/m^3$ )
- $\mu$  = dynamic viscosity of water ( $kg/s*m$ )
- $k$  = intrinsic permeability ( $m^2$ )

The term  $Cd^2$  is known as the intrinsic (or specific) permeability. The intrinsic permeability depends solely on the properties of the solid material, including pore size distribution, tortuosity, specific surface, and porosity. Typical values for the intrinsic

permeability for compacted solid waste in a landfill are in the range between about  $10^{-11}$  and  $10^{-12}$  m<sup>2</sup> in the vertical direction and about  $10^{-10}$  m<sup>2</sup> in the horizontal direction.

#### **2.4.2. Chemical Properties of MSW**

Information on the chemical composition of the components that constitute MSW is important in evaluating alternative processing and recovery options. For example, feasibility of combustion depends on the chemical composition of the solid wastes. Typically, wastes can be thought of as a combination of semimoist combustible and noncombustible materials. If solid wastes are to be used as fuel, the four most important properties to be known are:

1. Proximate analysis
2. Fusing point of ash
3. Ultimate analysis (major elements)
4. Energy content

- **Proximate Analysis**

Proximate analysis for the combustible components of MSW includes the following tests:

1. Moisture (loss of moisture when heated to 105°C for 1 h)
2. Volatile combustible matter (additional loss of weight on ignition at 950°C in a covered crucible)
3. Fixed carbon (combustible residue left after volatile matter is removed)
4. Ash (weight of residue after combustion in an open crucible)

- **Fusing Point of Ash**

The fusing point of ash is defined as that temperature at which the ash resulting from the burning of waste will form a solid (clinker) by fusion and agglomeration. Typical fusing temperatures for the formation of clinker from solid waste range from 2000 to 2200°F (1100 to 1200°C).

- **Ultimate Analysis of Solid Waste Components**

The ultimate analysis of a waste component typically involves the determination of the per cent C (carbon), H (hydrogen), O (oxygen), N (nitrogen), S (sulfur) and ash. Because of the concern over the emission of chlorinated compounds during combustion, the determination of halogens is often included in an ultimate analysis. The results of the ultimate analysis are used to characterize the chemical composition of the organic matter in MSW. They are also used to define the proper mix of waste materials to achieve suitable C/N ratios for biological conversion processes. Typical data on the ultimate analysis of the combustible components in residential MSW is given in Table 2.3 (Tchobanoglous et al., 1993)

Table 2.3. Typical data on the ultimate analysis of the combustible components in residential MSW

Component	Per cent by weight (dry basis)					
	Carbon	Hydrogen	Oxygen	Nitrogen	Sulfur	Ash
Organic						
Food wastes	48.0	6.4	37.6	2.6	0.4	5.0
Paper	43.5	6.0	44.0	0.3	0.2	6.0
Cardboard	44.0	5.9	44.6	0.3	0.2	5.0
Plastics	60.0	7.2	22.8	—	—	10.0
Textiles	55.0	6.6	31.2	4.6	0.15	2.5
Rubber	78.0	10.0	—	2.0	—	10.0
Leather	60.0	8.0	11.6	10.0	0.4	10.0
Yard wastes	47.8	6.0	38.0	3.4	0.3	4.5
Wood	49.5	6.0	42.7	0.2	0.1	1.5
Inorganic						
Glass	0.5	0.1	0.4	<0.1	—	98.9
Metals	4.5	0.6	4.3	<0.1	—	90.5
Dirt, ash, etc.	26.3	3.0	2.0	0.5	0.2	68.0

- **Energy Content of Solid Waste Components**

The energy content of the organic components in MSW can be determined (1) by using a full scale boiler as a calorimeter, (2) by using a laboratory bomb calorimeter and (3) by calculation, if the elemental composition is known. Because of the difficulty in instrumenting a full-scale boiler, most of the data on the energy content of the organic components of MSW are based on the results of bomb calorimeter tests.

### 2.4.3. Biological Properties of MSW

Excluding plastic, rubber, and leathex-components, the organic fraction of most MSW can be classified as follows:

- Water-soluble constituents, such as sugars, starches, amino acids, and various organic acids,
- Hemicellulose, a condensation product of five- and six-carbon sugars,
- Cellulose, a condensation product of the six-carbon sugar glucose,
- Fats, oils, and waxes, which are esters of alcohols and long-chain fatty acids,
- Lignin, a polymeric material containing aromatic rings with methoxyl groups (-OCH<sub>3</sub>), the exact chemical nature of which is still not known (present in some paper products such as newsprint and fiberboard),
- Lignocellulose, a combination of lignin and cellulose,
- Proteins, which are composed of chains of amino acids.

Perhaps the most important biological characteristic of the organic fraction of MSW is that almost all of the organic components can be converted biologically to gases and relatively inert organic and inorganic solids. The production of odors and the generation of flies are also related to the putrescible nature of the organic materials found in MSW (Tchobanoglous et al., 1993).

### 3. INTEGRATED WASTE MANAGEMENT

The diversity and volume of solid waste rises while population of region increases. The amount of solid waste, and features show differences from country to country, city to city in the same region and even from neighborhood to neighborhood. This change depends on the level of income, consumption and usage patterns. All of waste can be taken under control with a good waste management. In any circumstances, uncontrolled solid waste does not occur in an integrated solid waste management system that planned under the most ideal conditions.

Disposal of waste to land is an inevitable component of every solid waste management system. Even if facilities are provided for recover and recycle materials, there will be always being need for land disposal of residual proportion of the waste originally produced. In some countries, cheap disposal methods are preferable and that is why the number of open dumps is increasing.

Solid waste landfills are heterogeneous environment. Once MSW is placed in landfill, a complex sequence of biologically, chemically and physically mediated events occurs which results in gaseous end products during the predominately anaerobic stabilization of solid waste organic fractions.

A powerful solid waste management system consists;

- Waste composition
- Classification, accumulation and process before collection
- Collection
- Transportation
- Separation, process and recycle and
- Final disposal

All of these steps should be considered as independently. In figure 3.1 shows the steps of solid waste management until final disposal (Akpınar, 2006).

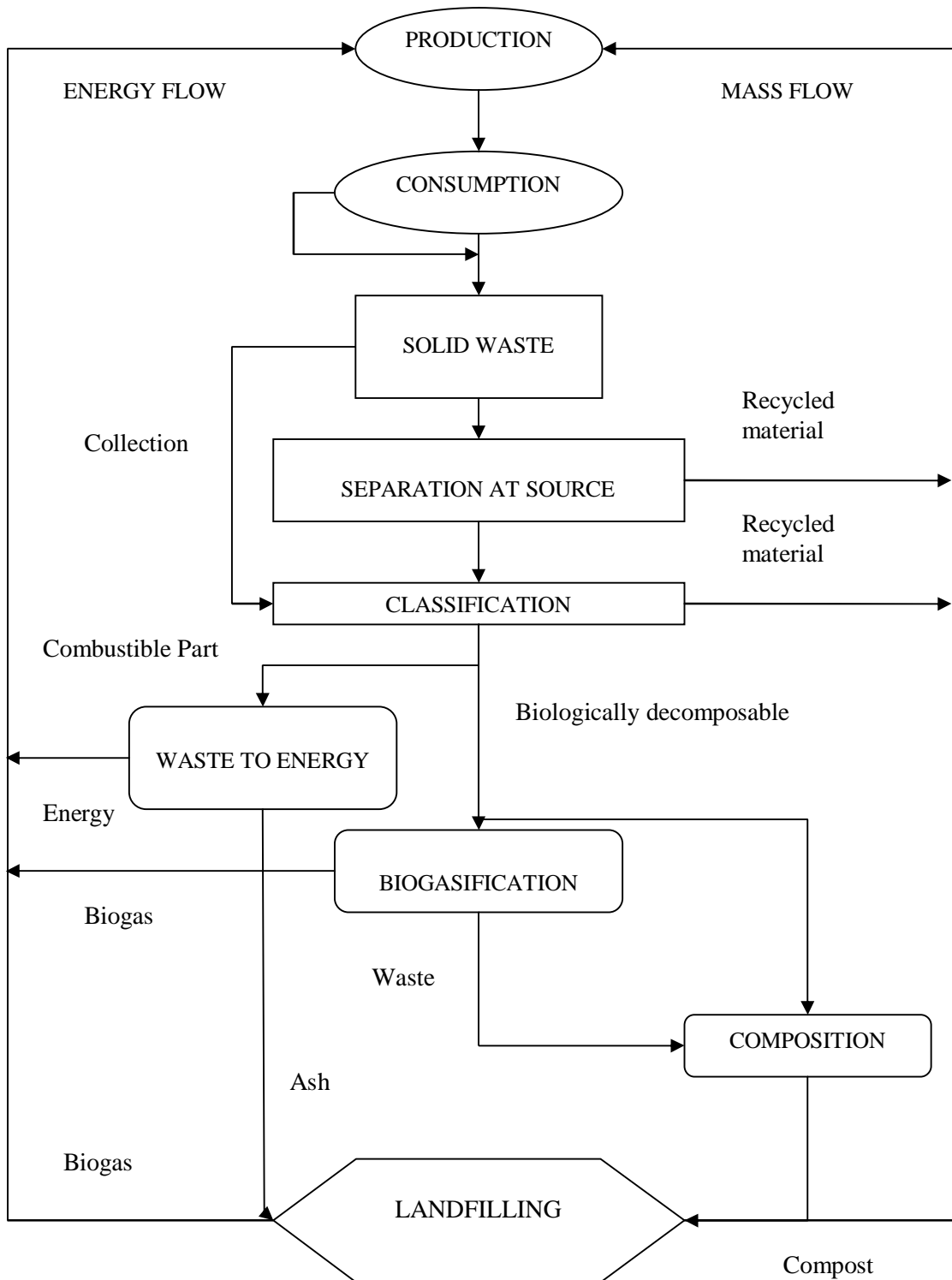

Figure 3.1. Integrated Solid Waste Management Flow Diagram (Akpınar, 2006)

At the present time, increase in consumption, population and environmental pollution as a result of a changing world, more efficient disposal methods have been developed whereas wild storage could accept the only method of waste disposal.

### **3.1. Waste Management Practices**

The two main types of waste management practices are open dumping, which is generally practiced in rural areas of developing countries, and land filling, generally practiced in developed countries and urban areas of developing countries. Both of these types of waste management can result in methane production if the waste contains organic matter. Gas recovery projects are appropriate for reducing methane emissions from both landfills and large open dumps. Small open dumps, common especially in rural areas of developing regions, are not suitable for gas recovery. Other waste disposal methods common in developing regions include the burning of waste for heating or cooking purposes, feeding to domestic animals, dumping in rivers or other bodies of water, or sweeping out on to the street and burying it. Landfills and large open dumps can be defined as follows:

#### **3.1.1. Landfills**

Landfills are designed specifically to receive wastes. Their design reflects a precise engineering component, which allows for the controlled disposal of waste. Landfill design and management is becoming increasingly sophisticated in many countries, as the environmental consequences of uncontrolled dumping are better understood.

New landfill design standards in many countries are ensuring that landfills are lined before receiving waste, and also that there are provisions for the safe control, and removal where appropriate, of gas and leachate generated. Good waste management practices ensure that waste is compacted, to minimize the use of void space. All these factors can encourage the rapid development and maintenance of anaerobic conditions within the landfill, and result in methane production (USEPA, 1996).

### 3.1.2. Large Open Dumps

Large open dumps are sites which have been deemed appropriate for waste disposal. Wastes in open dumps generally decompose aerobically, producing no methane. However, there is some evidence that some methane production does occur, but the amount has not been quantified. Some large open dumps will be candidates for gas recovery. Key characteristics that make large open dumps attractive for gas recovery include:

- *Geology*, The site should essentially be a "hole" in the ground. The "hole" could be a natural depression (e.g., pits or canyons) or man-made. Furthermore, the dump site should be large: at least 7 to 10 meters deep and covering an area of approximately 50 to 60 hectares.
- *Waste Characteristics*: The waste should be compact and wet. Concentrated waste, usually near the bottom of an open dump, will provide the anaerobic environment necessary for gas production.
- *Liquid Control*: Good surface drainage and facilities to control leachate should be available. Additionally, the site should not be prone to flooding or "ponding."

Large open dumps that meet the above requirements would be considered candidates for recovery. Additionally, large open dumps that are being rehabilitated and upgraded to "landfill status" may also be attractive, candidates for gas recovery. In particular, gas recovery can be an important aspect of efforts to upgrade the site.

As the first step, it must be assessed whether landfills or large open dumps exist in the country. The most likely place for these facilities is near large urban centers. City waste management personnel are generally most knowledgeable about whether such facilities exist and where, they are located. Making contact with these individuals to identify whether landfills or large open dumps exist is an important first step in conducting this initial screening (USEPA, 1996).

## **4. LAND FILLING**

### **4.1. Introduction**

Waste storage in the land one of the oldest and most used one of waste disposal methods. Haphazard disposal of solid waste to land, leachate and uncontrolled gas is defined as wild storage. Unfortunately, the indiscriminate storage of waste land is common throughout the world.

Landfill design and construction is a continuous activity that is completed only when all of the available or permitted capacity of the site has been filled with solid waste. Once that happens, the landfill must be closed, the final action of a facility that is to receive no more solid wastes. To ensure the functioning of environmental controls during closure and for a period of time after closure, a closure plan must be developed early in the life of a landfill and the elements of postclosure care required by federal state of state laws (Tchobanoglous et al., 1993).

### **4.2. Landfilling Objectives**

The principal objective of landfilling (Table 4.1) is the safe long-term disposal of solid waste, both from a health and environmental viewpoint; hence the term ‘sanitary landfill’ which is often used. Sanitary landfill describes an operation in which the wastes to be disposed of compacted and covered with a layer of soil at the end of each working day. As there are emissions from the process (landfill gas and leachate), these also need to be controlled and treated as far as possible (Nag and Vizayakumar, 2005).

Table 4.1. Landfilling: key considerations (Nag and Vizayakumar, 2005)

Landfill can deal with all waste materials	
Essentially a waste treatment process with the following outputs:	Landfill gas Leachate Inert solid waste
The waste treatment process parameters can be optimised. e.g.	Dry containment Leachate circulation Lining technology Landfill gas and leachate collection
Can be used to reclaim land (or sea)	
Should avoid groundwater catchment and extraction areas	

### 4.3. Landfill Site Design and Operation

Landfills are the physical facilities used for the disposal of residual solid wastes in the surface soils of the earth. In the past, the term sanitary landfill was used to denote a landfill in which the waste placed in the landfill was covered at the end of each day's operation. A sanitary landfill is also sometimes identified as a solid waste management unit. Landfilling is the process by which residual solid waste is placed in a landfill. Landfilling includes monitoring of the incoming waste stream, placement and compaction of the waste, and installation of landfill environmental monitoring and control facilities. A typical landfill sample is shown in Figure 4.1.



Figure 4.1. Typical landfill site (Akpınar, 2006)

Modern MSW landfills differ greatly from simple land disposal. Today's MSW landfills which have evolved in design and operating procedures over the last 20 years, are very different from landfills of even 5 or 10 years ago. Design improvements have reduced environmental impacts and improved the efficient use of resources.

A schematic of a typical MSW landfill is shown in Figure 4.2. Note that in the completed landfill, the waste is enclosed by cover material at the top and by a liner system at the bottom. Appropriate systems are in place to control contaminated water and gas emissions and reduce adverse impacts on the environment. Key terms used in MSW landfill design include the following:

- **Waste management boundary**

The waste management unit boundary is the boundary around the area occupied by the waste in a landfill. It is measured in square meters or in acres.

- **Liner**

The liner is a system of clay layers and/or geosynthetic membrane esused to collect leachate and reduce or prevent contaminant flow to groundwater.

- **Cover**

A typical MSW landfill has two forms of cover consisting of soil and geosynthetic materials: (1) a daily cover placed over the waste at the close of each day's operations and (2) a final cover, or cap, which is the material placed over the completed landfill to control infiltration of water, gas emission to the atmosphere, and erosion. It also protects the waste from long-term contact with the environment.

- **Leachate**

Leachate is a liquid that has passed through or emerged from solid waste and contains soluble, suspended, or miscible materials removed from such waste. Leachate typically flows downward in the landfill but may also flow laterally and escape through the side of the landfill.

- **Leachate collection system**

Pipes are placed at the low areas of the liner to collect leachate for storage and eventual treatment and discharge. Leachate flow over the liner to the pipes is facilitated by placing a drainage blanket of soil or plastic netting over the liner. An alternative to collection pipes is a special configuration of geosynthetic materials that will hydraulically transmit leachate to collection points for removal.

- **Landfill gas**

Generated by the anaerobic decomposition of the organic wastes, landfill gas is a mixture of methane and carbon dioxide, plus trace gas constituents.

- **Gas control and recovery system**

A series of vertical wells or horizontal trenches containing permeable materials and perforated piping is placed in the landfill to collect gas for treatment or productive use as an energy source.

- **Gas monitoring probe system**

Probes placed in the soil surrounding the landfill above the groundwater table to detect any gas migrating from the landfill.

- **Groundwater monitoring well system**

Wells placed at an appropriate location and depth for taking water samples that are representative of groundwater quality. The goal of MSW landfilling is to place residuals in the land according to a coordinated plan designed to minimize environmental impacts, maximize benefits, and keep the resource and financial cost as low as possible. To achieve these ends, the solid waste manager and the landfill owner and operator must carefully plan the development of new facilities and optimize the performance of existing facilities (USEPA, 1995).

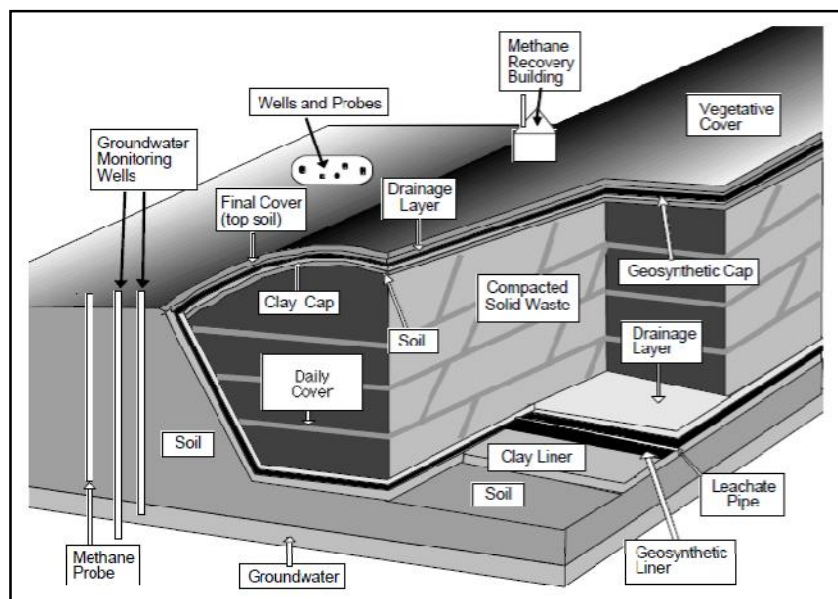

Figure 4.2. A schematic of a typical MSW landfill (USEPA, 1995)

#### 4.4. Landfill Leachate

The leachate collection system normally consists of a network of perforated pipes, from which the leachate can be either gravity drained or pumped to a leachate treatment plant. The most significant influence on leachate quantity is the amount of rainfall, which will vary seasonally. Leachate production begins shortly after the process of landfilling begins and may continue for a period of hundreds or possibly thousands of years. This is demonstrated in Figure 4.3, which presents an estimation of the time when different compounds in leachate will no longer be considered harmful to the environment. A storage sump or pool is often used so that surges in leachate production can be flow balanced before entering the treatment process. Landfill management practices greatly affect leachate quality. Acceleration of the early phases of decomposition is needed to produce low concentrations of organic matter and heavy metals in the leachate.

This can be facilitated by having a low waste input rate, moisture control (by leachate recirculation) or by having a composted bottom layer of waste. Leachate treatment can be carried out on or off site by physical, chemical or biological methods. One of the most common methods of leachate treatment is the use of aerated lagoons (McDougall et al., 2001).

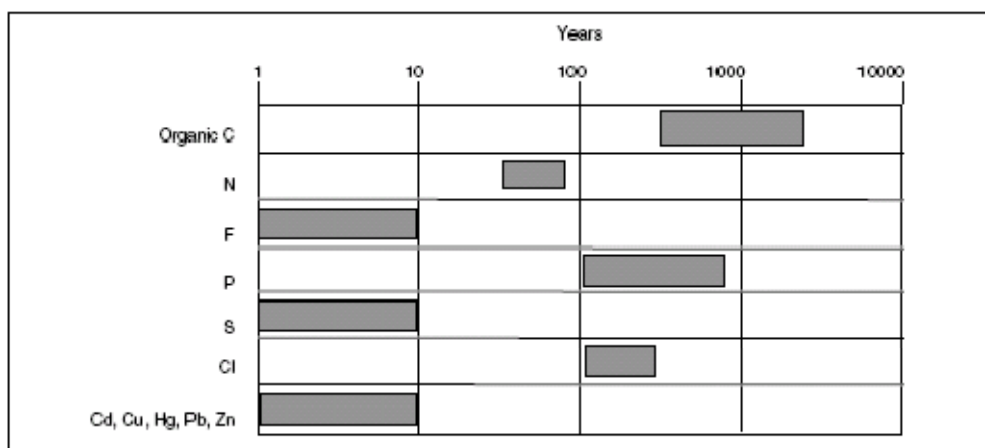

Figure 4.3. Estimated times when compounds in leachate become harmless to the environment. The grey boxes represent the time periods when the environmental burden of each compound in landfill leachate becomes negligible (McDougall et al., 2001)

The structure of one form of lined landfill site for containment of leachate is shown in Figure 4.4. The bottom liner of the site can either be a plastic (often butyl rubber or HDPE) or a layer of another low-permeability material such as clay. Whilst the permeability of the synthetic material is lower, they are vulnerable to mechanical puncture and so can then act as a point source for leaking leachate. By comparison, clay barriers (often a number of metres thick) are not subject to such localised failure, though they act as a diffuse source of leachate over the whole area of the landfill site.

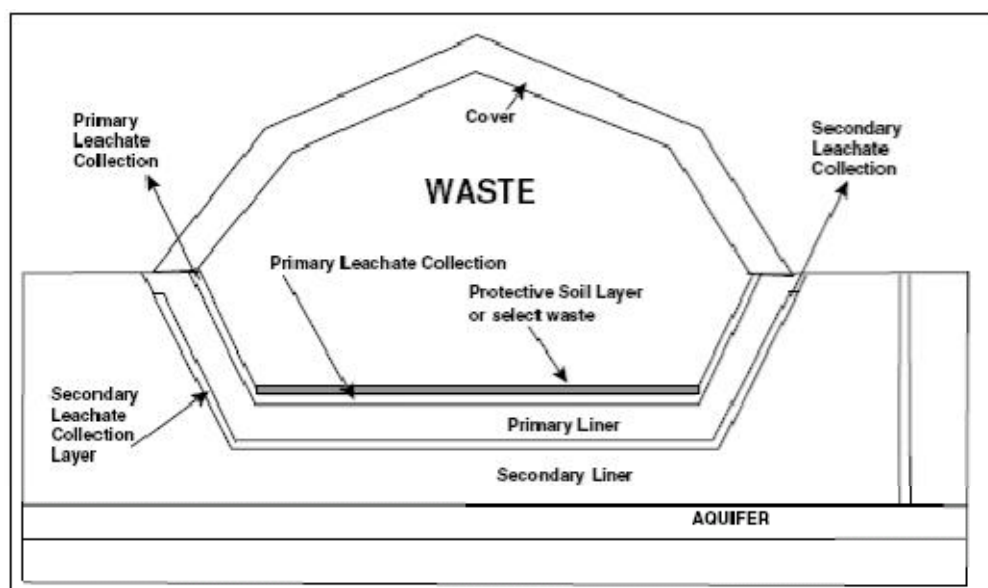

Figure 4.4. Simplified plan of a landfill with a double liner system (McDougall et al., 2001)

As well as a choice of material types, there is also a range of options in the way liners are laid down. As liner systems increase in complexity their costs will increase, but the risk of failure decreases, so there is less likelihood of expensive remediation work following leakages. The simplest form of barrier consists of a single liner, normally with a leachate collection system above the liner. Rather than rely on one type of liner material, a single composite liner system has two or more liners of different materials in direct contact with each other. In this design it is common to have a leachate collection system above a plastic liner, on top of a low permeability clay layer. The liner system shown in Figure 4.2 is a double liner system: two liners with a leachate collection system above the upper (primary) liner, and a leachate detection system between the two layers. The leachate

detection system has a high permeability to allow any leachate that has leaked through the primary liner to be drawn off. Again, each layer in a double liner system may either be a single liner or a composite of two or more materials. A detailed cross-section of the liner systems required for materials containing different amounts of Total Organic Carbon (TOC) is presented in Figure 4.5 (McDougall et al., 2001).

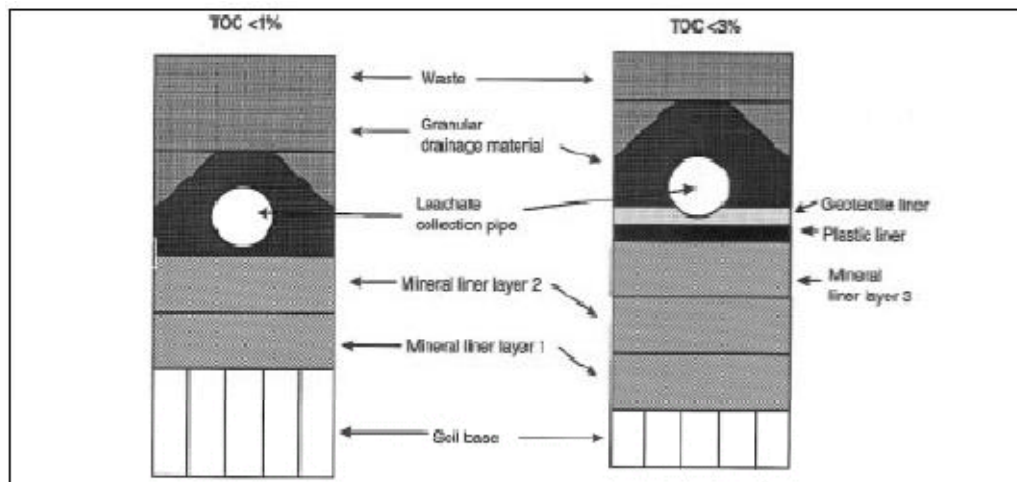

Figure 4.5. Landfill liner systems required for materials containing different levels of Total Organic Carbon (McDougall et al., 2001)

Once the liner system has been installed, a cover of clay, soil or other inert material is normally applied to protect it from mechanical damage. Waste is then deposited and compacted, and layers of inert material (soil, coarse composted material) are normally added to sandwich the waste. The actual working face of the landfill is kept small and the fresh waste is covered by landfill cover material at the end of every day to reduce the nuisance from wind-blown material, and to keep off rodents, birds and other potential pathogen-carrying vermin (McDougall et al., 2001).

#### 4.5. Landfill Gases

A solid waste landfill can be conceptualized as a biochemical reactor, with solid waste and water as the major inputs and with landfill gas and leachate as the principal outputs. Material stored in the landfill includes partially biodegraded organic material and the other inorganic waste materials originally placed in the landfill. Landfill gas control

systems are employed to prevent unwanted movement of landfill gas into the atmosphere or the lateral and vertical movement through the surrounding soil. Recovered landfill gas can be used to produce energy or can be flared under controlled conditions to eliminate the discharge of harmful constituents to the atmosphere.

#### **4.5.1. Composition and Characteristics of Landfill Gas**

Landfill gas is composed of a number of gases that are present in large amounts (the principal gases) and a number of gases that are present in very small amounts (the trace gases). The principal gases are produced from the decomposition of the organic fraction of MSW. Some of the trace gases, although present in small quantities, can be toxic and could present risks to public health.

#### **4.5.2. Principal Landfill Gas Constituents**

Gases found in landfills include ammonia ( $\text{NH}_3$ ), carbon dioxide ( $\text{CO}_2$ ), carbon monoxide ( $\text{CO}$ ), hydrogen ( $\text{H}_2$ ), hydrogen sulfide ( $\text{H}_2\text{S}$ ), methane ( $\text{CH}_4$ ), nitrogen ( $\text{N}_2$ ), and oxygen ( $\text{O}_2$ ). The typical percentage distribution of gases found in a MSW landfill is reported in Table 4.2. Data on molecular weight and density are presented in Table 4.3. Methane and carbon dioxide are the principal gases produced from the anaerobic decomposition of the biodegradable organic waste components in MSW. When methane is present in the air in concentrations between 5 and 15 per cent, it is explosive. Because only limited amounts of oxygen are present in a landfill when methane concentrations reach this critical level, there is little danger that the landfill will explode. However, methane mixtures in the explosive range can form if landfill gas migrates off-site and mixes with air (Tchobanoglous et al., 1993).

Table 4.2. Typical constituents found in MSW landfill gas (Tchobanoglous et al., 1993)

<b>Component</b>	<b>Per cent (dry volume basis)</b>
Methane	45-60
Carbon dioxide	40-60
Nitrogen	2-5
Oxygen	0.1-1.0
Sulfides, disulfides, mercaptans, etc.	0-1.0
Ammonia	0.1-1.0
Hydrogen	0-0.2
Carbon monoxide	0-0.2
Trace constituents	0.01-0.6
<b>Characteristic</b>	<b>Value</b>
Temperature, °F	100-120
Specific gravity	1.02-1.06
Moisture content	Saturated
High heating value, Btu/sft <sup>3</sup>	400-550

Table 4.3. Molecular weight, density, and specific weight of gases found in sanitary landfill at standard conditions (0°C, 1 atm) (Tchobanoglous et al., 1993)

Gas	Formula	Molecular weight	Density (g/L)	Specific weight (lb/ft <sup>3</sup> )
Air		28.97	1.2928	0.0808
Ammonia	NH <sub>3</sub>	17.03	0.7708	0.0482
Carbondioxide	CO <sub>2</sub>	44.00	1.9768	0.1235
Carbonmonoxide	CO	28.00	1.2501	0.0781
Hydrogen	H <sub>2</sub>	2.016	0.0898	0.0056
Hydrogen-sulfide	H <sub>2</sub> S	34.08	1.5392	0.0961
Methane	CH <sub>4</sub>	16.03	0.7167	0.0448
Nitrogen	N <sub>2</sub>	28.02	1.2507	0.0782
Oxygen	O <sub>2</sub>	32.00	1.4289	0.0892

#### 4.5.3. Trace Landfill Gas Constituents

The California Integrated Waste Management Board has performed an extensive landfill gas sampling program as part of its landfill gas characterization study. Summary data on the concentrations of trace compounds found in landfill gas samples from 66 landfills are reported in Table 4.4. In another study conducted in England, gas samples were collected from three different landfills and analyzed for 154 compounds. A total of 116 organic compounds were found in landfill gas. Many of the compounds found would be classified as volatile organic compounds (VOCs). The data presented in Table 4.4 are representative of the trace compounds found at most MSW landfills. The presence of these gases in the leachate that is removed from the landfill will depend on their concentrations in the landfill gas in contact with the leachate. Note that the occurrence of significant concentrations of VOCs in landfill gas is associated with older landfills that accepted industrial and commercial wastes containing VOCs. In newer landfills in which the disposal of hazardous waste has been banned, the concentrations of VOCs in the landfill gas have been extremely low.

Table 4.4. Typical concentrations of trace compounds found in landfill gas at 66 MSW landfills (Tchobanoglous et al., 1993)

Compound	Concentration, ppbV <sup>1</sup>		
	Median	Mean	Maximum
Acetone	0	6838	240000
Benzene	932	2057	39000
Chlorobenzene	0	82	1640
Chloroform	0	245	12000
1,1-Dichloroethane	0	2801	36000
Dichloromethane	1150	25694	620000
1,1-Dichloroethene	0	130	4000
Diethylene chloride	0	2835	20000
<i>trans</i> -1,2-Dichloromethane	0	36	850
2,3-Dichloropropane	0	0	0
1,2-Dichloropropane	0	0	0
Ethylene bromide	0	0	0
Ethylene dichloride	0	59	2100
Ethylene oxide	0	0	0
Ethylene benzene	0	7334	87500
Methyl ethyl ketone	0	3092	130000
1,1,2-Trichloroethane	0	0	0
1,1,1-Trichloroethane	8125	615	14500
Trichloroethylene	0	2079	32000
Toluene	260	34907	280000
1,1,2,2- Tetrachloroethane	1150	246	16000
Tetrachloroethylene	0	5244	180000
Vinyle chloride	0	3508	32000
Styrenes	0	1517	87000
Vinyl acetate		5663	240000
Xylenes		2651	38000

<sup>1</sup> 1 ppbV= parts per billion by volume.

#### 4.5.4. Generation of the Principal Landfill Gases

The generation of the principal landfill gases is thought to occur in five more or less sequential phases, as illustrated in Figure 4.6.

- **Phase I-initial adjustment**

Phase I is the *initial adjustment phase*, in which the organic biodegradable components in MSW undergo microbial decomposition as they are placed in a landfill and soon after. In Phase I, biological decomposition occurs under aerobic conditions, because a certain amount of air is trapped within the landfill. The principal source of both the aerobic and the anaerobic organisms responsible for waste decomposition is the soil material that is used as a daily and final cover. Digested wastewater treatment plant sludge, disposed of in many MSW landfills, and recycled leachate are other sources of organisms (Tchobanoglous et al., 1993)

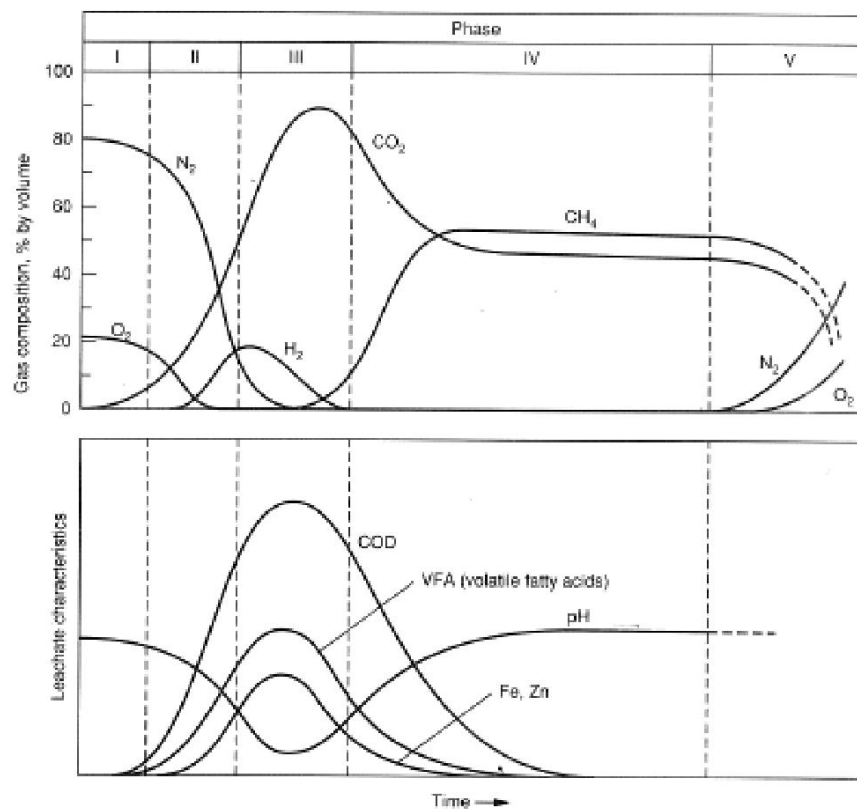

Figure 4.6. Generalized phases in the generation of landfill gases (I= initial adjustment, II= transition phase, III= acid phase, IV= methane fermentation and V= maturation phase)

(Tchobanoglous et al., 1993)

- **Phase II—transition phase**

In Phase II, identified as the *transition phase*, oxygen is depleted and anaerobic conditions begin to develop. As the landfill becomes anaerobic, nitrate and sulfate, which can serve as electron acceptors in biological conversion reactions, are often reduced to nitrogen gas and hydrogen sulfide. The onset of anaerobic conditions can be monitored by measuring the oxidation/reduction potential of the waste. Reducing conditions sufficient to bring about the reduction of nitrate and sulfate occur at about -50 to -100 millivolts. The production of methane occurs when the oxidation/reduction potential values are in the range from -150 to -300 millivolts. As the oxidation/reduction potential continues to decrease, members of the microbial community responsible for the conversion of the organic material in MSW to methane and carbon dioxide begin the three-step process, with conversion of the complex organic material to organic acids and other intermediate products as described in Phase III. In Phase II, the pH of the leachate, if any is formed; starts to drop due to the presence of organic acids and the effect of the elevated concentrations of CO<sub>2</sub> within the landfill (see Fig. 4.6.).

- **Phase III—acid phase**

In Phase III, the *acid phase*, the microbial activity initiated in Phase II accelerates with the production of significant amounts of organic acids and lesser amounts of hydrogen gas. The first step in the three-step process involves the enzyme-mediated transformation (hydrolysis) of higher-molecular mass compounds (e.g., lipids, polysaccharides, proteins, and nucleic acids) into compounds suitable for use by microorganisms as a source of energy and cell carbon. The second step in the process (acidogenesis) involves the microbial conversion of the compounds resulting from the first step into lower-molecular mass intermediate compounds as typified by acetic acid (CH<sub>3</sub>COOH) and small concentrations of fulvic and other more complex organic acids. Carbon dioxide (CO<sub>2</sub>) is the principal gas generated during Phase III. Smaller amounts of hydrogen gas (H<sub>2</sub>) will also be produced. The microorganisms involved in this conversion, described collectively as nonmethanogenic, consist of facultative and obligate anaerobic bacteria. These microorganisms are often identified in the engineering literature as *acidogens* or *acid formers*.

The pH of the leachate, if formed, will often drop to a value of five or lower because of the presence of the organic acids and the elevated concentrations of CO<sub>2</sub> within the landfill. The biochemical oxygen demand (BOD<sub>5</sub>), the chemical oxygen demand (COD), and the conductivity of the leachate will increase significantly during Phase III due to the dissolution of the organic acids in the leachate. Also, because of the low pH values in the leachate, a number of inorganic constituents, principally heavy metals, will be solubilized during Phase III. Many essential nutrients are also removed in the leachate in Phase III. If leachate is not recycled, the essential nutrients will be lost from the system. It is important to note that if leachate is not formed, the conversion products produced during Phase III will remain within the landfill as sorbed constituents and in the water held by the waste as defined by the field capacity.

- **Phase IV—methane fermentation phase**

In Phase IV, the *methane fermentation phase*, a second group of microorganisms, which convert the acetic acid and hydrogen gas formed by the acid formers in the acid phase to CH<sub>4</sub> and CO<sub>2</sub>, becomes more predominant. In some cases, these organisms will begin to develop toward the end of Phase III. The microorganisms responsible for this conversion are strict anaerobes and are called methanogenic. Collectively, they are identified in the literature as *methanogens* or *methane formers*. In Phase IV, both methane and acid formation proceed simultaneously, although the rate of acid formation is considerably reduced.

Because the acids and the hydrogen gas produced by the acid formers have been converted to CH<sub>4</sub> and CO<sub>2</sub> in Phase IV, the pH within the landfill will rise to more neutral values in the range of 6.8 to 8.0. In turn, the pH of the leachate, if formed, will rise, and the concentration of BOD<sub>5</sub> and COD and the conductivity value of the leachate will be reduced. With higher pH values, fewer inorganic constituents can remain in solution; as a result, the concentration of heavy metals present in the leachate will also be reduced.

- **Phase V—maturation phase**

Phase V, the *maturation phase*, occurs after the readily available biodegradable organic material has been converted to CH<sub>4</sub> and CO<sub>2</sub> in Phase IV. As moisture continues to migrate through the waste, portions of the biodegradable material that were previously unavailable will be converted. The rate of landfill gas generation diminishes significantly in Phase V, because most of the available nutrients have been removed with the leachate during the previous phases and the substrates that remain in the landfill are slowly biodegradable. The principal landfill gases evolved in Phase V are CH<sub>4</sub> and CO<sub>2</sub>. Depending on the landfill closure measures, small amounts of nitrogen and oxygen may also be found in the landfill gas. During maturation phase, the leachate will often contain humic and fulvic acids, which are difficult to process further biologically (Tchobanoglous et al., 1993).

#### **4.5.5. Factors Affecting Landfill Gas Generation**

The rate at which landfill gas is generated depends on many factors. Continuing decomposition and gas production can be expected for up to 30 to 100 years, but these occur at a high level for a much shorter period of time. There is no simple equation or rate constant that can adequately describe the rate of decomposition in a landfill due to the existence of many types of decomposable matter. However, it is possible to at least characterize the importance of the various factors in qualitative terms (McBean et al., 1995).

- **Moisture Content**

Moisture content is considered the most important parameter in refuse decomposition and gas production. It provides the aqueous environment necessary for gas production and also serves as a medium for transporting nutrients and bacteria throughout the landfill. The subsistence moisture level required by methanogenic bacteria is very low and occurs even in the driest of landfills. Landfill gas is therefore produced at all landfills. Gas production is increased only moderately as moisture content increases up to field capacity because the nutrients, alkalinity, pH, and bacteria are not transferred readily within the landfill. If the

moisture content in the refuse exceeds field capacity, however, the moving liquid carries nutrients, bacteria, and alkalinity to other areas within the landfill, creating an environment favorable for increased gas production.

The overall moisture content of refuse as received at a landfill ranges typically from a low of 15 to 20 per cent to a high of 30 to 40 per cent on a wet weight basis. Typical average moisture content is 25 per cent. Table 4.5 gives refuse moisture contents for various types of refuse.

Table 4.5. Refuse Moisture Content (McBean et al., 1995)

Refuse Component	Moisture Content (% dry weight)			
	Sample 1	Sample 2	Sample 3	Sample 4
Food waste	151	133	118	122
Garden waste	67	99	102	91
Paper	29	28	38	36
Plastic, rubber, etc.	21	20	15	20
Textiles	38	28	28	25
Wood	13	17	22	18
Metals	6	7	4	4
Glass, ceramic	1	1	0	1
Ash, dirt, rock	10	26	15	13
Fires	47	47	47	51

- **Nutrient Content**

Bacteria in a landfill require various nutrients for growth, primarily carbon, hydrogen, oxygen, nitrogen, and phosphorus, but also small amounts of sodium, potassium, sulfur, calcium, magnesium, and other trace metals. Certain nutrients are required not only in sufficient quantities but in certain ratios as well. The greater the quantity of easily "digested" nutrients, the greater the rate of gas generation; nutrients that are more difficult for the bacteria to utilize result in a lower rate of generation. Numerous toxic materials, such as heavy metals, can retard bacterial growth and consequently retard gas production.

- **Bacterial Content**

The bacteria involved in aerobic biodegradation and methanogenesis exist in the refuse and soils. However, seeding the refuse with bacteria from another source can result in a faster rate of development of the bacteria population. Digested wastewater sludge and digester effluent can be sources of additional bacteria.

- **pH Level**

The optimum pH ranges for anaerobic digestion is 6.7 to 7.5 or closes to neutral. Within the optimum pH range, methanogens grow at a high rate, so methane production is maximized. Outside the optimum range, below a pH of 6 or above 8, methane production is severely limited. The pH levels in a landfill may be influenced by the presence of industrial wastes, alkalinity, infiltration of groundwater, and the relative rates of organic acid production and methane generation. Young leachates typically have a pH of less than 6 to 7 due to the presence of volatile fatty acids.

The pH of the refuse and leachate significantly influences chemical and biological processes. An acidic pH increases the solubility of many constituents, decreases adsorption, and increases the ion exchange between the leachate and organic matter. An acidic pH is generally the result of the formation of organic acids during the initial stages of anaerobic decomposition. These acids become the substrate for the methanogenic bacteria. As these organics begin to proliferate, the pH should rise as the acids are converted to methane. If the pH is too low, however, methanogenesis will be inhibited.

- **Temperature**

Temperature conditions within a landfill influence the type of bacteria that are predominant and the level of gas production. As mentioned previously, the optimum temperature range for mesophilic bacteria is 30°C to 35°C, whereas the optimum for thermophilic bacteria is 45°C to 65°C. Thermophiles generally produce higher gas generation rates; however, most landfills exist in the mesophilic range. Landfill temperatures often reach a maximum within 45 days after placement of wastes as a result

of the aerobic microbial activity. Landfill temperatures then decrease once anaerobic conditions develop. Greater temperature fluctuations are typical in the upper zones of a landfill as a result of changing ambient air temperature. Figure 4.7 illustrates temperature fluctuations at various depths with the refuse at a shallow, relatively dry landfill. Smaller temperature fluctuations occur in the central and deeper zones because of the insulating effects of the overlying refuse mass. Landfill refuse at 15 m depth or greater is relatively unaffected by ambient air temperatures and has been observed with temperatures as high as 70°C. Isolated zones of higher temperature may exist within a landfill of generally lower temperature. These higher temperatures tend to appear at deep landfills (greater than 40 m) where sludge is added and/or leachate is recirculated. At shallow landfills, ambient temperatures can affect the refuse temperature (McBean et al., 1995).

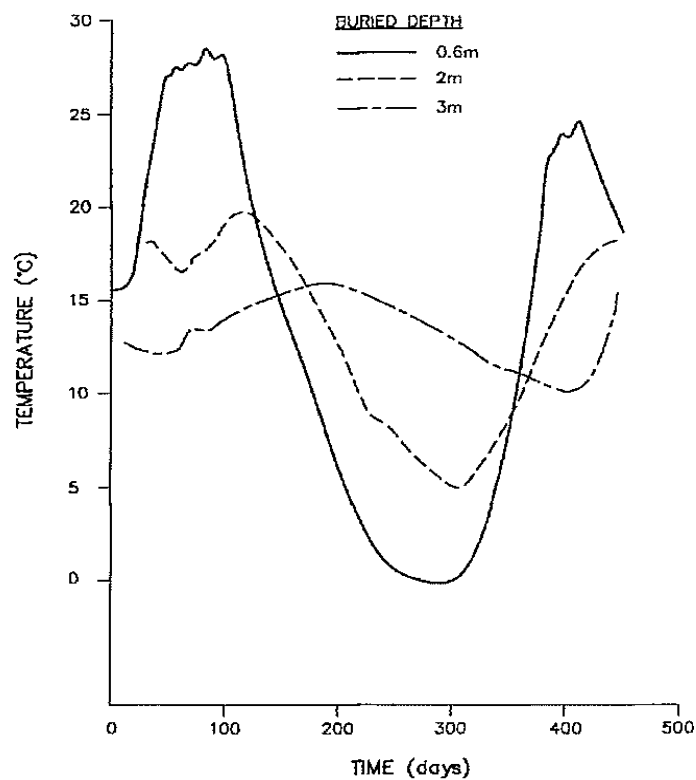

Figure 4.7. Temperature variability as a function of time at various depths (McBean et al., 1995)

- **Particle Size on Gas Production**

Smaller particle sizes of shredded refuse are believed to have a beneficial effect on landfill gas production. A reduced particle size exposes a greater surface area of the refuse to the important parameters affecting gas production, including moisture, nutrients, and bacteria. A well-shredded mass of waste should result in increased microbial activity and transfer of nutrients, particularly if sufficient moisture is present.

- **Density on Gas Production**

There are very few conclusive data available regarding the effect of density on landfill gas production. Within the typical density range of most landfills of 300 to 450 kg/m<sup>3</sup> in place, there does not appear to be a significant relationship between refuse density and gas production.

#### **4.5.6. Duration of Phases**

The duration of the individual phases in the production of landfill gas will vary depending on the distribution of the organic components in landfill, the availability of nutrients, the moisture content of waste, moisture routing through the fill, and the degree of initial compaction. For example, if several loads of brush are compacted together the carbon/nitrogen ratio and the nutrient balance may not be favorable for the production of landfill gas. Likewise, the generation of landfill gas will be retarded if sufficient moisture is not available. Increasing the density of the material placed in the landfill will decrease the possibility of moisture reaching all parts of the waste and, thus, reduce the rate of bioconversion and gas production. Typical data on the percentage distribution of principal gases found in a newly completed landfill as a function of time are reported in Table 4.6 (Tchobanoglous et al., 1993).

Table 4.6. Percentage distribution of landfill gases observed during the first 48 months after the closure of landfill cell (Tchobanoglous et al., 1993)

Time interval since cell completion, months	Average, per cent by volume		
	Nitrogen, N <sub>2</sub>	Carbon dioxide, CO <sub>2</sub>	Methane, CH <sub>4</sub>
0-3	5.2	88	5
3-6	3.8	76	21
6-12	0.4	65	29
12-18	1.1	52	40
18-24	0.4	53	47
24-30	0.2	52	48
30-36	1.3	46	51
36-42	0.9	50	47
42-48	0.4	51	48

The generalized chemical reaction for the anaerobic decomposition of solid waste can be written as

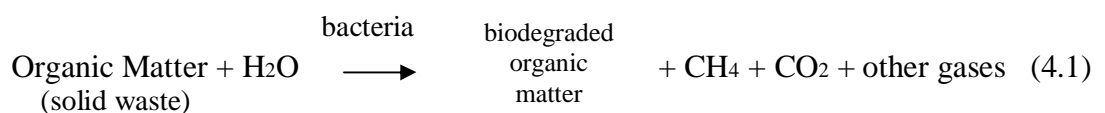

Note that the reaction requires the presence of water. Landfills lacking sufficient moisture content have been found in a “mummified” condition, with decades-old newsprint still in readable condition. Hence, although the total amount of gas that will be produced from solid waste derives straightforwardly from the reaction stoichiometry, local hydrologic conditions affect significantly the rate and the period of time over which that gas production takes place (Tchobanoglous et al., 1993).

In general, the organic materials present in solid wastes can be divided into two classifications: (1) those materials that will decompose rapidly (three months to five years) and (2) those materials that decompose slowly (up to 50 years or more). The rapidly and slowly decomposable components of the organic fraction of MSW are identified in Table 4.7.

Table 4.7. Rapidly and slowly biodegradable organic constituents in MSW  
(Tchobanoglous et al., 1993)

<i>Organic waste component</i>	<i>Rapidly biodegradable</i>	<i>Slowly biodegradable</i>
Food wastes	√	
Newspaper	√	
Office paper	√	
Cardboard	√	
Plastics <sup>2</sup>		
Textiles		√
Rubber		√
Leather		√
Yard wastes	√ <sup>3</sup>	√ <sup>4</sup>
Wood		√
Misc. organics		√

<sup>2</sup> Plastics are generally considered nonbiodegradable.

<sup>3</sup> Leaves and grass trimmings. Typically, 60 per cent of the yard wastes are considered rapidly biodegradable.

<sup>4</sup> Woody portions of yard wastes.

#### 4.5.7. Variation in Gas Production with Time

Under normal conditions, the rate of decomposition, as measured by gas production, reaches a peak within the first two years and then slowly tapers off, continuing in many cases for periods up to 25 years or more. If moisture is not added to the wastes in a well-compacted landfill, it is not uncommon to find materials in their original form years after they were buried.

The variation in the rate of gas production from the anaerobic decomposition of the rapidly (five years or less, some highly biodegradable wastes are decomposed within days of being placed in a landfill) and slowly (5 to 50 years) biodegradable organic materials in MSW can be modeled as shown in Fig. 4.8. As shown in Fig. 4.8., the yearly rates of decomposition for rapidly and slowly decomposable material are based on a triangular gas production model in which the peak rate of gas production occurs one and five years, respectively, after gas production starts. Gas production is assumed to start at the end of the first full year of landfill operation. The area under the triangle is equal to one half the base times the altitude, therefore, the total amount of gas produced from the waste placed the first year of operation is equal to

$$\begin{aligned} & \textit{Total gas produced, ft}^3/\textit{lb} \\ & = 1/2 (\textit{base, yr}) \times (\textit{altitude, peak rate of gas production, ft}^3/\textit{lb*yr}) \end{aligned} \quad (4.2)$$

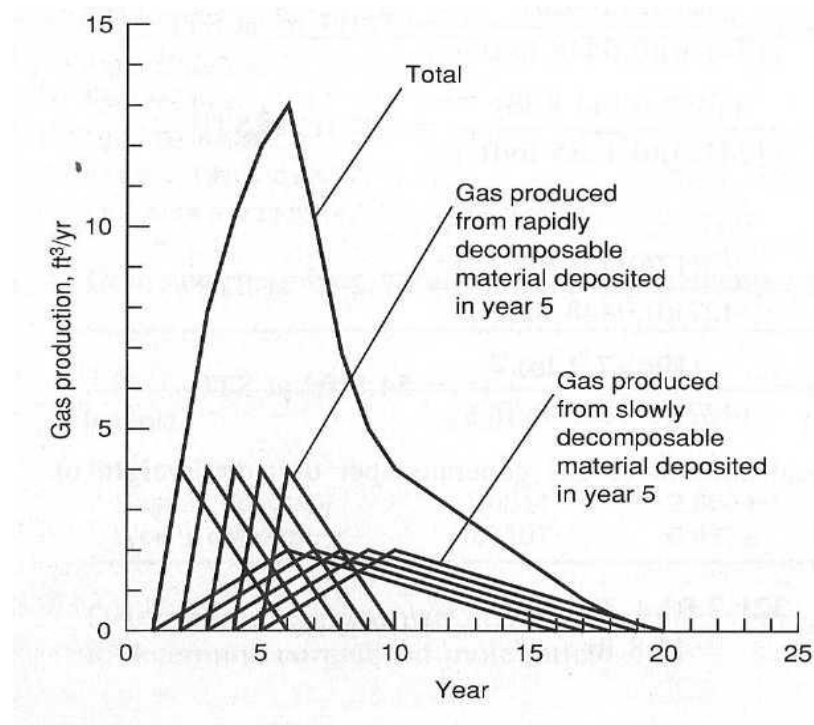

Figure 4.8. Graphical representation of gas production over a five year period from the rapidly and slowly decomposable organic materials placed in a landfill (Tchobanoglous et al., 1993)

Using a triangular gas production model, the total rate of gas production from a landfill in which wastes were placed for a period of five years is obtained graphically by summing the gas produced from the rapidly and slowly biodegradable portions of the MSW deposited each year (see Fig. 4.9.) (Nag et al., 2005).

The anaerobic breakdown of organic material within a landfill results in the production of gas, the composition of which varies over time, as shown in Figure 4.9.

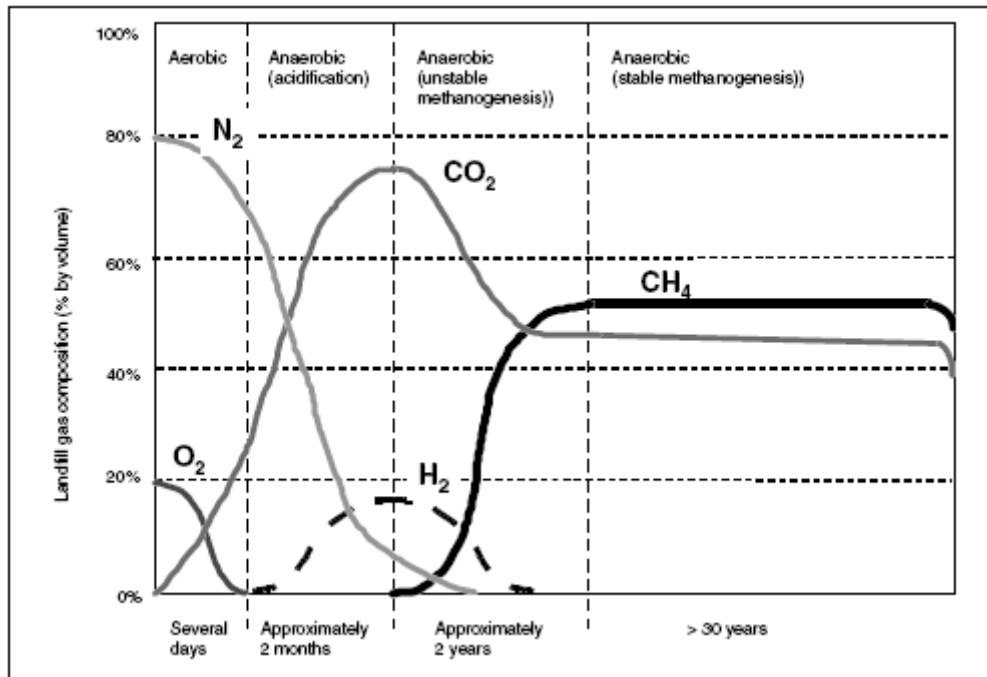

Figure 4.9. The composition of landfill gas over time (Nag et al., 2005)

Landfill gas is collected using a system of either vertical or horizontal perforated pipes. Since the gas will migrate horizontally along the layers of waste, vertical collection pipes are likely to collect gas more effectively. The density of pipes will vary across the landfill, with the greatest density needed at the periphery to prevent the migration of the gas laterally from the site. Pumped extraction of gas is needed for efficient collection, and thus less odour and emission problems. Once collected, the gas can either be flared off, to destroy the methane and organic contaminants, or used as a fuel. As produced, landfill gas is saturated with water vapour, and contains many trace impurities. This leads to a highly corrosive condensate, so if the gas is going to be used in a gas engine for energy recovery, gas cleaning is normally required. Similarly, if the gas is to be piped elsewhere for use as a fuel, in many cases it is purified to remove the contaminants and the carbon dioxide, the latter to increase its calorific value (Nag et al., 2005).

#### 4.6. Environmental Monitoring Systems

Environmental monitoring is necessary to ensure that the integrity of the landfill is maintained with respect to the uncontrolled release of any contaminants to the environment. In most instances, the selection of facilities and procedures to be included in

a closure plan will be a function of the environmental control facilities used during landfill operations before closure (see table 4.8.).

Table 4.8. Environmental monitoring facilities that are installed during landfill construction and operations and used after landfill closure (Tchobanoglous et al., 1993)

Monitoring facility	Function during operations	Function after closure
Groundwater monitoring wells		
Upgradient	Water sampling at location to get background water quality	Same functions as during operation
Downgradient	Water sampling at location to detect movement of leachate contaminants; if contaminants are present, stop operations and correct problem with liner; wells function as a control variable for operations	Water sampling at location to detect any leachate plume created by a leaking liner; a data reference location for defining the direction and rate of movement for a contaminant plume
Vadose zone lysimeters	Sampling location to detect liquids in soils above groundwater; if liquids are present, stop operations and determine the cause; correct problems before restarting operations	Sampling location to detect liquids in soils above groundwater; if liquids are present, complete additional investigations as to cause; correct any problems as required by regulatory agency
Gas vents	Sampling location for combustible gases	Sampling location for combustible gases; gas extraction wells for control and removal of methane gas after closure
Leachate treatment facilities	Leachate quantity measurement and quality sampling location	Same functions as during operations
Stormwater holding basins	Retain stormwater for regulated release of basins; measure quantity and sample for quality	Same functions as during operations

Selection of environmental monitoring methods and facilities for closed landfills will be most successful when done in accordance with the guidelines of the regulatory agency. Unfortunately, many state regulatory agencies have not yet developed landfill closure guidelines, so that solid waste management agencies are faced with the possibility of selecting environmental monitoring facilities that may be unacceptable under future guidelines. In the face of this uncertainty, designers should choose monitoring facilities

that can be used to track the movement of any landfill emissions to the water, air, and soil environments.

#### **4.6.1. Water**

Monitoring of water quality and movement is done to identify leachate leakage from the landfill. Monitoring facilities will be placed in soils under the landfill liner and in the uppermost groundwater aquifer. In dry climates, when moisture does not penetrate to soil beneath the landfill, the monitoring capacities must be capable in the functioning in the vadose zone. The groundwater aquifer is monitored by wells.

#### **4.6.2. Air**

A landfill closure plan will show the manner in which methane and other gases are to be controlled and discharged to the atmosphere. Gas monitoring is also used to assess the degree of the biological activity in the landfill. Typical gas monitoring equipment used at closed landfills includes explosive gas meters, hydrogen sulfide meters, and sample collection equipment and containers for sample to be analyzed off-site.

#### **4.6.3. Soil**

In most landfill closure plans, cover soil is one of the most important features. It must be placed under strict construction supervision and then maintained to prevent loss of soils. Environmental monitoring of soil includes measuring land surface settlement, soil slippage and land surface erosion. Inspection closed landfill requires training and good judgment in making visual observations and in the use of survey monuments to monitor cover layer movement (Tchobanoglous et al., 1993).

### **4.7. Control of Landfill Gases**

Under normal conditions, gases produced in soils are released to the atmosphere by means of molecular diffusion. In the case of an active landfill, the internal pressure is usually greater than atmospheric pressure and landfill gas will be released by both

convective (pressure-driven) flow and diffusion. Other factors influencing the movement of landfill gases include the sorption of the gases into liquid or solid components and the generation or consumption of a gas component through chemical reactions or biological activity.

#### **4.7.1. Passive Control of Landfill Gases**

The movement of landfill gases is controlled to reduce atmospheric emissions, to minimize the release of odorous emissions, to minimize subsurface gas migration, and to allow for the recovery of energy from methane. Control systems can be classified as passive or active. In passive gas control systems, the pressure of the gas that is generated within the landfill serves as the driving force for the movement of the gas. In active gas control systems, energy in the form of an induced vacuum is used to control the flow of gas. For both the principal and trace gases, passive control can be achieved during times when the principal gases are being produced at a high rate by providing paths of higher permeability to guide the gas flow in the desired direction. A gravel-packed trench, for example, can serve to channel the gas to a flared vent system. When the production of the principal gases is limited, passive controls are not very effective because molecular diffusion will be the predominant transport mechanism. However, at this stage in the life of the landfill it may not be so important to control the residual emission of the methane in the landfill gas. Control of VOC emissions may necessitate the use of both passive and active gas control facilities.

*4.7.1.1. Pressure Relief Vents / Flares in Landfill Cover.* One of the most common passive methods for the control of landfill gases is based on the fact that the lateral migration of landfill gas can be reduced by relieving gas pressure within the landfill interior. For this purpose, vents are installed through the final landfill cover extending down into the solid waste mass (see Fig. 4.10.).

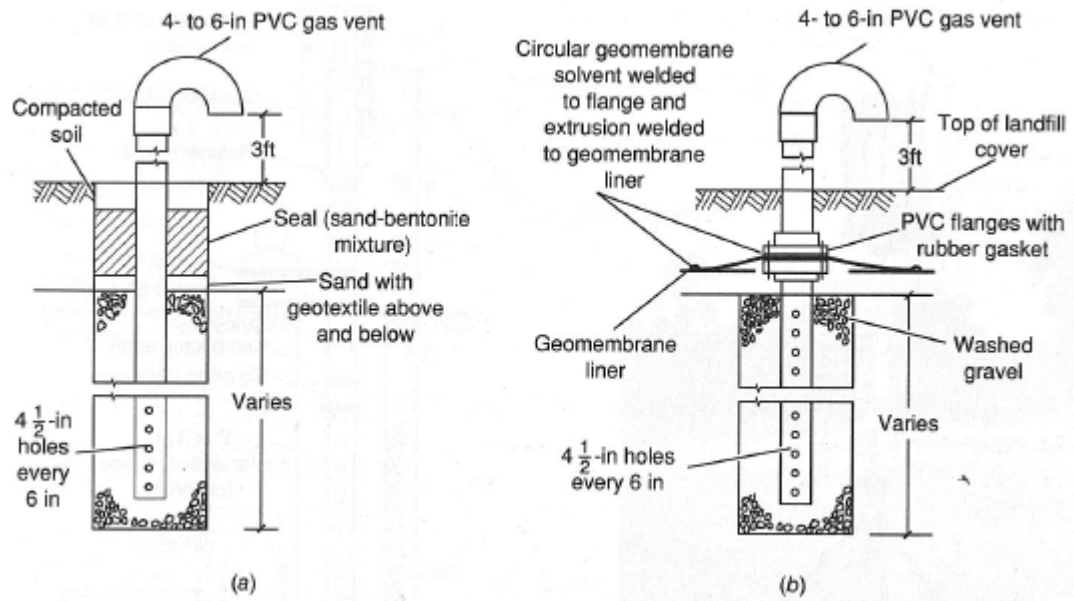

Figure 4.10. Typical gas vents used in the surface of a landfill for the passive control of landfill gas: (a) gas vent for landfill with a cover that does not contain a geomembrane liner and (b) gas vent for a landfill with a cover that contains a synthetic membrane liner (Tchobanoglous et al., 1993)

If the methane in the venting gas is of sufficient concentration, several vents can be connected together and equipped with a gas burner (see Fig. 4.10). Where waste gas burners are used the well should penetrate into the upper waste cells. The height of the waste burner can vary from 10 to 20 ft above the completed fill. The burner can be ignited either by hand or by a continuous pilot flame. To derive maximum benefit from the installation of a waste gas burner, a pilot flame should be used (see Fig. 4.11). It should be noted, however, that passive vents with burners may not achieve the VOC and odor destruction efficiencies that are required by many urban air quality control agencies, and, thus, their use is not considered good practice.

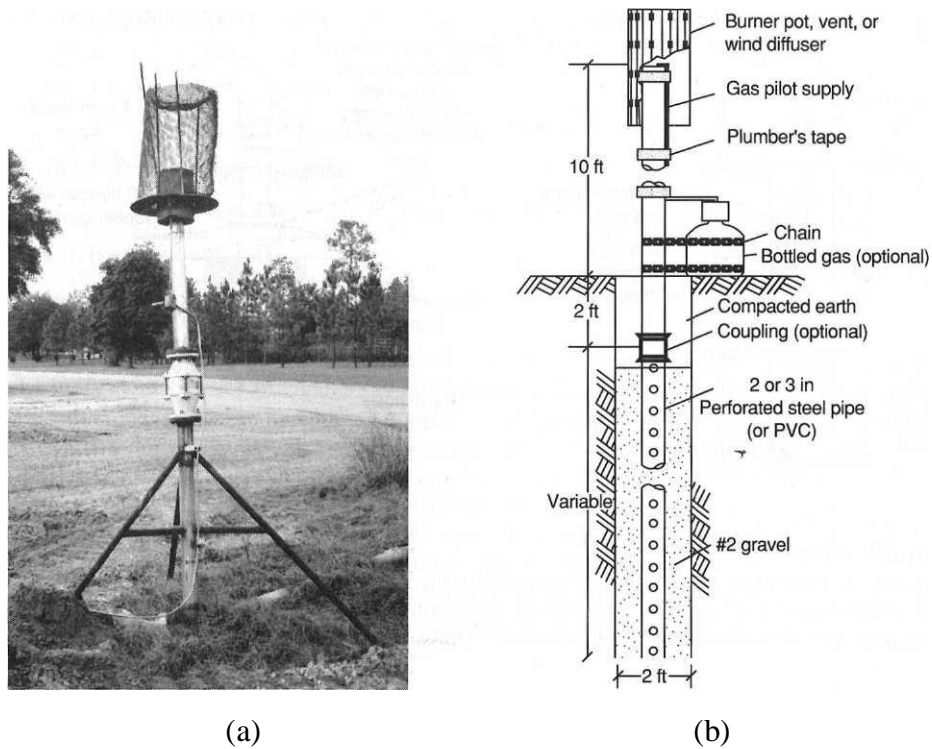

Figure 4.11. Typical candlestick type waste gas burner used to flare landfill gas from a well vent or several interconnected well vents: (a) without pilot flame and (b) with pilot flame (Tchobanoglous et al., 1993)

*4.7.1.2. Perimeter Interceptor Trenches.* A perimeter trench system, consisting of gravel-filled interceptor trenches containing horizontal perforated plastic pipe (typically polyvinyl chloride, PVC, or polyethylene, PE), can be used to intercept the lateral movement of landfill gases (see Fig. 4.12a). The perforated pipe is connected to vertical risers through which the landfill gas that collects in the trench backfill can be vented to the atmosphere. To facilitate gas collection in the trench, a membrane liner is often installed on the trench wall facing away from the landfill.

4.7.1.3. Perimeter Barrier Trench or Slurry Wall. Barrier trenches (see Fig. 4.12b) are usually filled with relatively impermeable materials such as bentonite or clay slurries. In this case, the trench becomes a physical barrier to lateral subsurface gas movement. Landfill gas is removed from the inside face of the barrier with gas extraction wells or gravel-filled trenches. However, slurry trenches may be subject to desiccation cracking when allowed to dry out, and hence are more commonly used in groundwater interception projects. The long-term effectiveness of barrier trenches for the control of the migration of landfill gases is uncertain.

4.7.1.4 Impermeable Barriers within Landfills. In modern landfills, the movement of landfill gases through adjacent soil formations is controlled by constructing barriers of materials that are more impermeable than the soil before filling operations start (see Fig. 4.12c). In connection with the control of leachate, the use of compacted clays and geomembranes of various types singly and in multilayer configurations is most common. Because the principal gases as well as the trace gases will diffuse through clay liners, many agencies now require the use of geomembranes to limit the movement of landfill gases (Tchobanoglous et al., 1993).

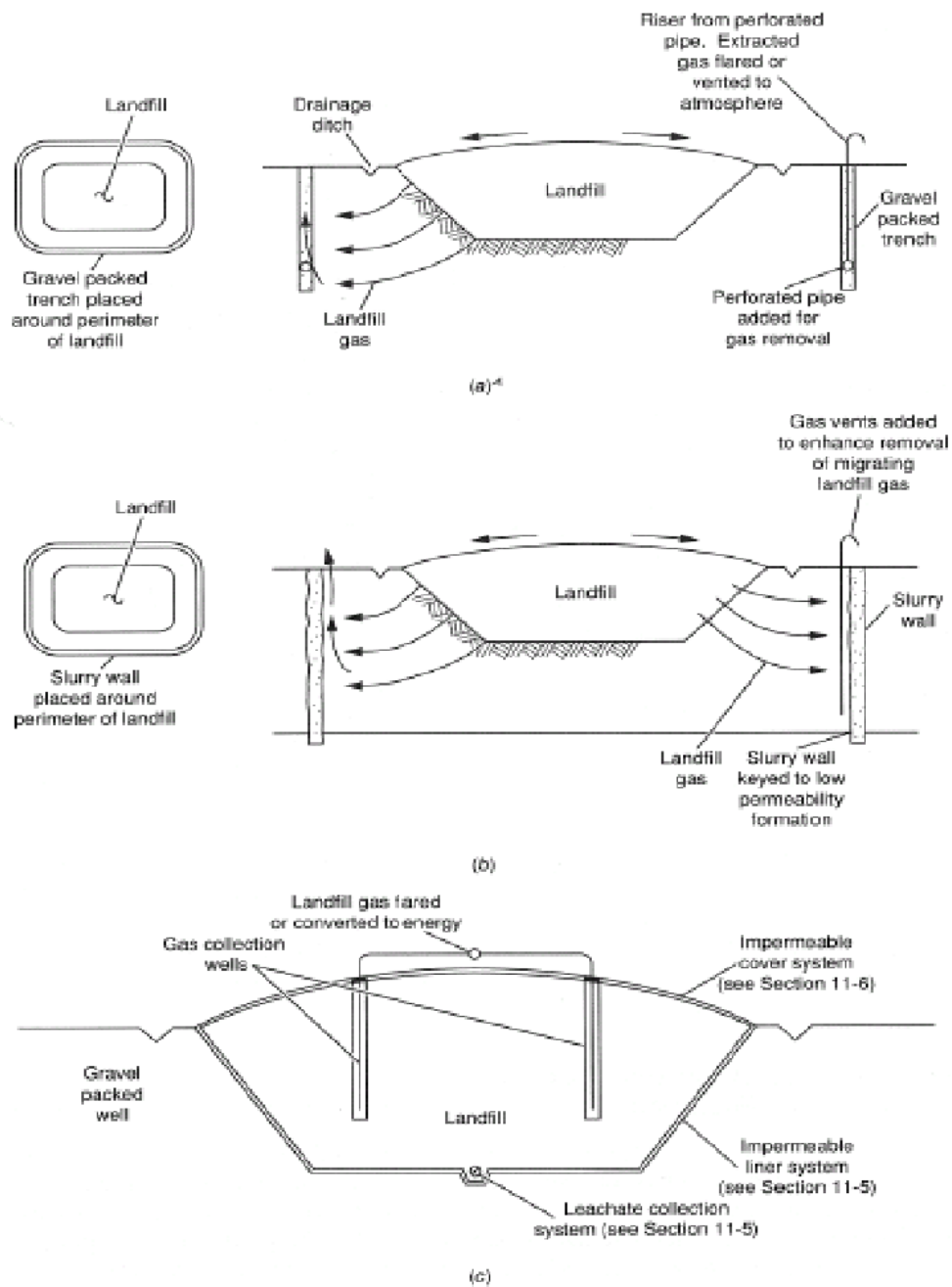

Figure 4.12. Passive facilities used for the control of landfill gas: (a) interceptor trench filled with gravel and perforated pipe, (b) perimeter barrier trench, and (c) use of impermeable liner in landfill. Note interceptor barrier perimeter trenches are used to control the off-site migration of landfill gas from existing unlined landfills (Tchobanoglous et al., 1993)

#### **4.7.2. Active Control of Landfill Gas with Perimeter Facilities**

The lateral movement of landfill gas can be controlled by using perimeter gas extraction wells and trenches and by creating a partial vacuum, which induces a pressure gradient toward the extraction well. The extracted gas is either flared to control the emission of methane and VOCs or used for the production of energy. The use of air injection wells is also considered in the following discussion.

*4.7.2.1. Perimeter Gas Extraction and Odor Control Wells.* Perimeter extraction wells (see Fig. 4.13a) are typically used in landfills with solid waste depths of at least 25 ft, where the distance between the landfill and off-site development is relatively small. They consist of a series of vertical wells installed either within the landfill along its edge or in the area between the edge of the landfill and the site boundary. The individual landfill gas extraction wells are connected by a common header pipe that in turn is connected to an electrically driven centrifugal blower, which induces a vacuum (negative pressure) in the collection header and the individual wells. When a flared, under controlled conditions, at the blower station. The extracted gas can also be utilized as an energy source if the amount of gas that can be collected is of sufficient quantity and quality.

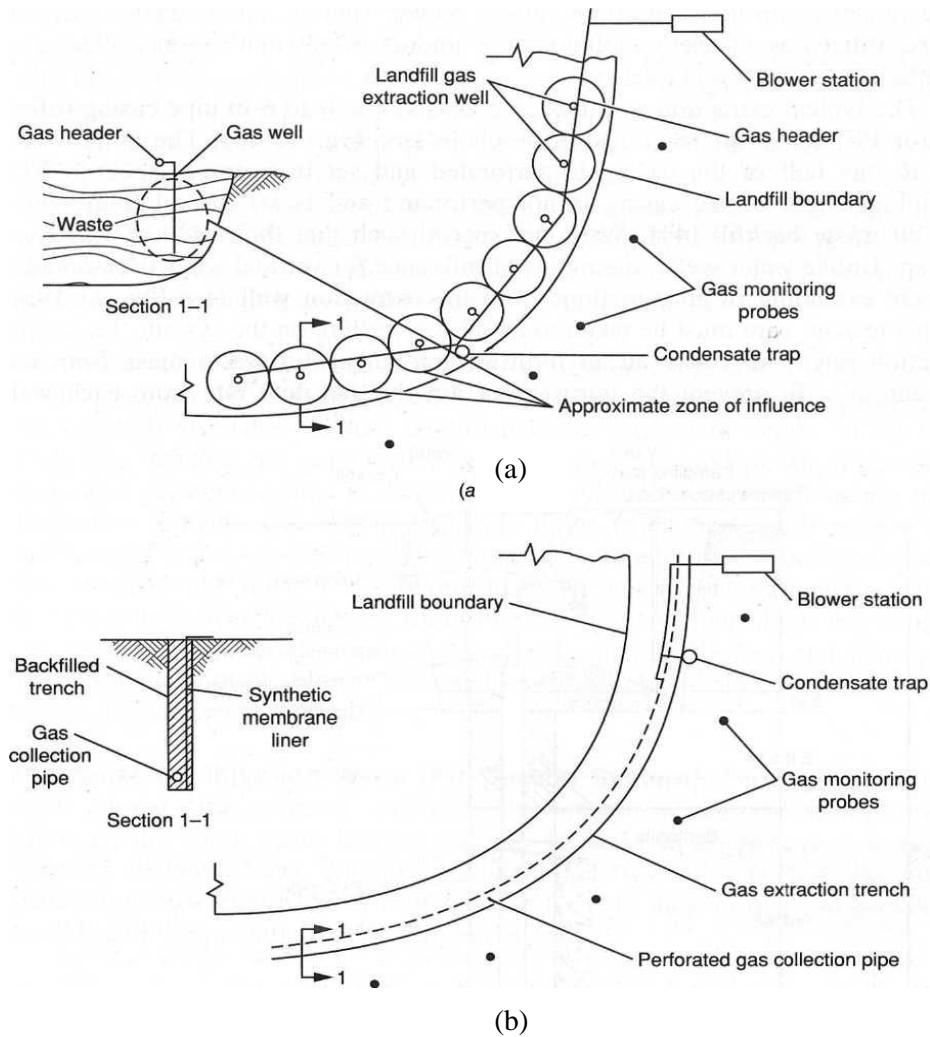

Figure 4.13. Active facilities used for the subsurface control of landfill gas migration: (a) perimeter landfill gas extraction wells and (b) perimeter landfill gas extraction trench (Tchobanoglous et al., 1993)

The typical extraction well design consists of a 4- to 6-in pipe casing (often PVC or PE) set in an 18- to 36-in borehole (see Fig. 4.14). The bottom one third to one half of the casing is perforated and set in a gravel backfill. The remaining length of the casing is not perforated and is set in soil (preferable) or solid waste backfill. Wells are spaced such that their radii of influence overlap. Unlike water wells, the radius of influence for vertical wells is essentially a sphere extending in all directions from the extraction well (see Fig.

4.13a). For this reason, care must be taken to avoid *overpulling* on the system. Excessive extraction rates can cause air to infiltrate into the solid waste mass from the adjacent soil.

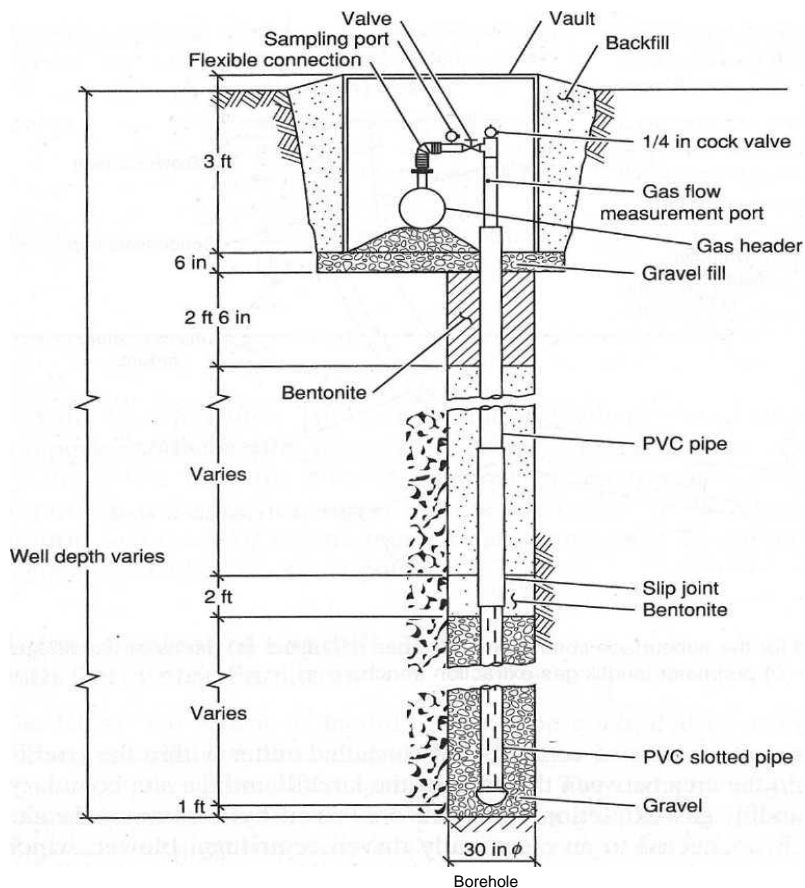

Figure 4.14. Representative detail of a landfill gas extraction well (Tchobanoglous et al., 1993)

To prevent the intrusion of air, the gas flow rate from each well must be controlled carefully. For this purpose, extraction wells are equipped with gas sampling ports and flow control valves. Depending on the depth of the landfill and other local conditions, well spacing for perimeter gas extraction wells will vary from 25 to 50 ft, although larger spacings have been used.

In large landfills, vertical perimeter wells are also used in conjunction with larger horizontal and vertical gas extraction wells located in the interior of the landfill. The

vertical perimeter wells are used to control the off-site migration of landfill gases from the edges and faces of the landfill. Where the perimeter wells are used for the control of odorous emissions from the surfaces of the landfill, the surfaces of the landfill are maintained at a slight vacuum.

4.7.2.2. Perimeter Gas Extraction Trenches. Perimeter extraction trenches (see Fig. 4.13b) are usually installed in native soil adjacent to the landfill perimeter. They are typically used for shallow landfill disposal sites with depths of 25 feet or less. The trenches are gravel-filled and contain perforated plastic pipes that are connected through laterals to a collection header and centrifugal suction blower. Extraction trenches can extend vertically down from the landfill surface to the depth of the solid waste or to groundwater and can be further sealed on the surface with a membrane liner. The suction blower creates a zone of negative pressure in each trench, which extends toward the solid waste. Landfill gas migrating into this zone is drawn into the perforated pipe and collection header, and subsequently vented or flared at the blower station. Flow adjustments can be made via control valves at each trench.

4.7.2.3. Perimeter Air Injection Wells (Air Curtain System). Perimeter air injection wells consist of a series of vertical wells installed in natural soils between the limits of the solid waste landfill and the facilities to be protected against the intrusion of landfill gas. Air injection wells are typically installed near landfills with solid waste depths of 20 ft or more in areas of undisturbed soil between the landfill and the potentially affected properties (Tchobanoglous et al., 1993).

### **4.7.3. Active Control of Landfill Gas with Vertical and Horizontal Gas Extraction Wells**

Both vertical and horizontal gas wells have been used for the extraction of landfill gas from within landfills. In some installations both types of wells have been used. The management of the condensate that forms when landfill gas is extracted is also an important element in the design of gas recovery systems.

4.7.3.1. Vertical Gas Extraction Wells. A typical gas recovery system using vertical gas extraction wells is illustrated in Fig. 4.15. The wells are spaced so that their radii of influence overlap (see Fig. 4.16). For completed landfills without gas recovery facilities, the radius of influence for gas wells is sometimes determined by conducting gas drawdown tests in the field. Typically, an extraction well is installed along with gas probes at regular distances from the well, and the vacuum within the landfill is measured as a vacuum is applied to the extraction well (Tchobanoglous et al., 1993).

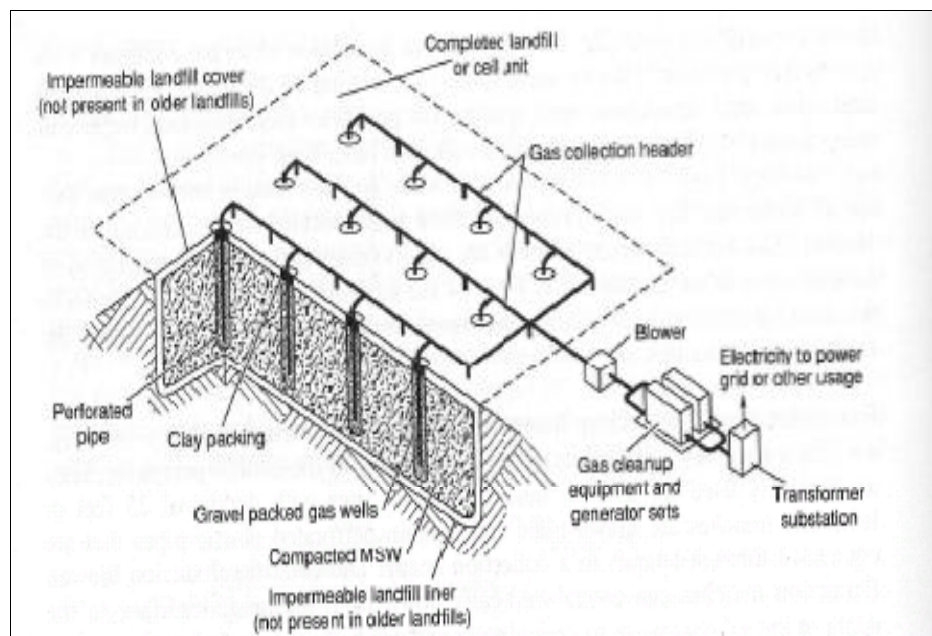

Figure 4.15. Landfill gas recovery system using vertical wells (Tchobanoglous et al., 1993)

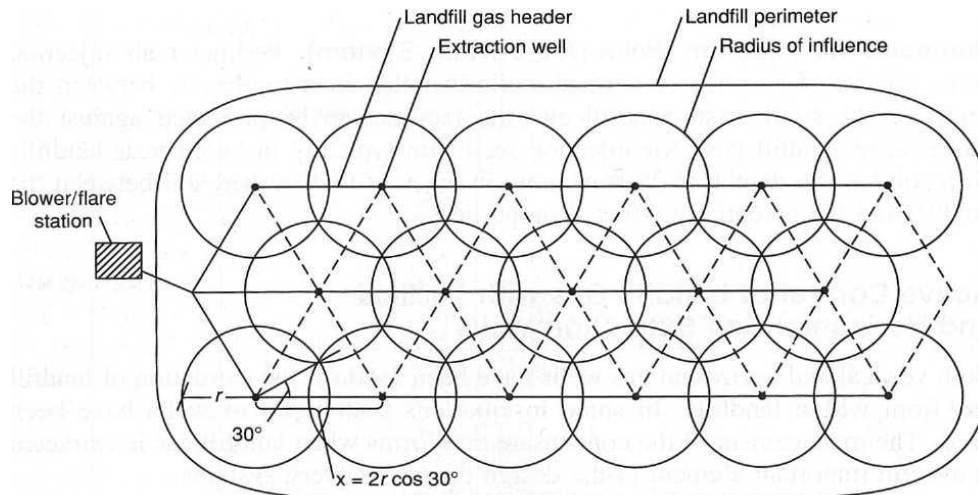

Figure 4.16. Equilateral triangular distribution for vertical gas extraction wells  
(Tchobanoglous et al., 1993)

Both short-term and long-term extraction tests can be conducted. Because the volume of gas produced will diminish with time, some designers prefer to use a uniform well spacing and to control the radius of influence of the well by adjusting the vacuum at the wellhead. Since the radius of influence of a vertical gas extraction well is essentially a sphere, the radius of influence will also depend on the depth of the landfill and on the design of the landfill cover. For deep landfills with a composite cover containing a geomembrane 150 to 200 ft spacing is common for landfill gas extraction wells. In landfills with clay and/or soil covers, a closer spacing (e.g., 100 ft) may be required to avoid pulling atmospheric gases into the gas recovery system.

Vertical gas extraction wells are usually installed after the landfill or portions of the landfill have been completed. In older landfills, vertical wells are installed both to recover energy and to control the movement of gases to adjacent properties. The typical extraction well design consists of 4 to 6 in pipe casing (usually PVC or PE) set in an 18 to 36 in borehole (see Fig. 4.14). The bottom third to one half of the casing is perforated and set in a gravel backfill. The remaining length of the casing is not perforated and is backfilled with soil and sealed with clay. Landfill gas recovery wells are typically designed to penetrate to 80 per cent of the depth of the waste in the landfill, because their radii of influence will extend to the bottom of the landfill. However, to allay the public's fear

concerning the escape of landfill gas, some designers now place gas recovery wells all the way to the bottom of the landfill. The available vacuum in the collection manifold at the well head is typically 10 in of water.

*4.7.3.2. Horizontal Gas Extraction Wells.* An alternative to the use of vertical gas recovery wells is the use of horizontal wells. Horizontal wells are installed after two or more lifts have been completed. The horizontal gas extraction trench is excavated in the solid waste using a backhoe. The trench is then backfilled halfway with gravel and a perforated pipe with open joints is installed (see Fig. 4.17). The trench is then filled with gravel and capped with solid waste. By using a gravel-filled trench and a perforated pipe with open joints, the gas extraction trench remains functional even with the differential settling that will occur in the landfill with the passage of time. The horizontal trenches are installed at approximately 80 ft vertical intervals and at 200 ft horizontal intervals (Tchobanoglous et al., 1993).

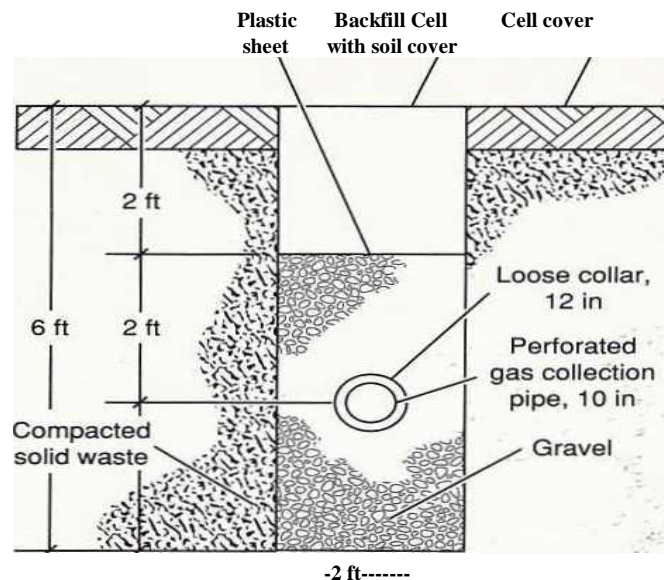

Figure 4.17. Details of horizontal gas extraction trench (Tchobanoglous et al., 1993)

#### 4.8. Current Landfilling Activity

Reliance on landfill for solid waste disposal varies geographically around the world (Figure 4.18.). Countries such as the UK have traditionally used landfilling as the predominant disposal route, partly because of its geology and mineral extraction industry, which has left many empty quarries that can be filled with waste. Such sites, however, may not always be in suitable locations for minimizing their environmental burdens (see below). Conversely, countries such as The Netherlands, where the lack of physical relief and high water table have meant that large void spaces are not available, have had to develop alternative disposal routes (USEPA, 1996).

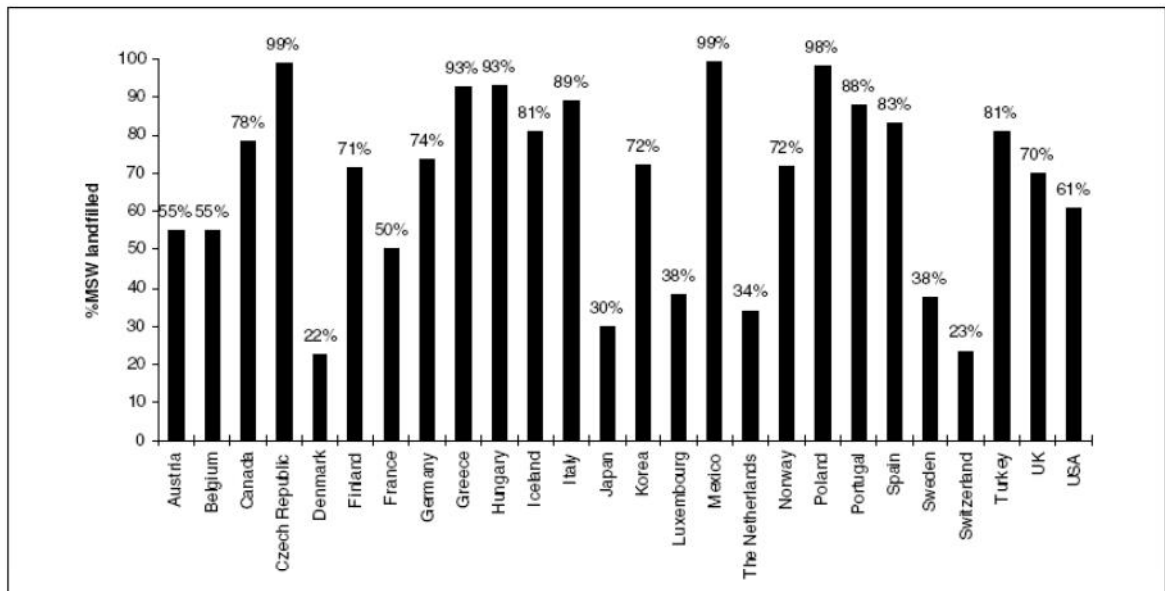

Figure 4.18. Percentage of MSW landfilled in OECD countries (USEPA, 1996)

## 5. USE FOR ENERGY

The most attractive emissions reduction projects are those where the energy in the recovered gas can be used or sold. The value of the energy derived from the gas can more than offset the cost of collecting and processing the gas. The purpose of this step is to assess whether it is likely that there is a suitable use for the gas recovered from the landfill or large open dump. It should be noted that this energy use criterion is not absolutely essential. Methane emissions will also be reduced if the landfill gas is recovered and flared. However, there is unlikely to be any monetary benefit if the gas is flared. Consequently, those projects that provide useful energy are generally more attractive emissions reduction options from the cost perspective.

There are three primary approaches to using the gas recovered: (1) direct use of the gas locally (either on-site or nearby); (2) generation of electricity and distribution through the power grid; and (3) injection into a gas distribution grid. Direct use of the gas locally is often the simplest and most cost-effective approach. The medium quality gas can be used in a wide variety of ways, including: residential use (cooking, hot water heating, and space heating); boiler fuel for district heating; and various industrial uses requiring process heat or steam (such as in cement manufacture, glass manufacture, and stone drying).

If a direct use is not practical, the gas can be used to generate electricity by using it to fuel a reciprocating engine or turbine. If the electricity is not required on site, it can be distributed through the local power grid. This approach requires close coordination with the electric power authority.

In some cases, the gas can be injected into a gas distribution grid. If a medium quality gas system exists, the gas can be injected with minimum processing. Natural gas pipeline systems, however, typically transport high quality gas that is over 95 per cent methane. Prior to injecting the recovered gas into such a system it would need to be processed extensively to remove the CO<sub>2</sub> and any other impurities. Processing the gas to meet high quality pipeline standards often drives the cost of production higher than the costs of alternative fuels. As a result, this option is usually not economically viable.

However, in an environment of extremely high fuel costs, upgrading landfill gas might be a profitable option.

Other energy utilization options may present themselves on a case-by-case basis. For example, compressed gas can be used to power refuse collection trucks that bring refuse to the landfill or open dump. Alternatively, there may be a specialized need for gas nearby, such as may be needed by a heated greenhouse. However, these are niche applications which have not been proven cost effective in developing countries (USEPA, 1996).

Table 5.1 presents a simple checklist to assess whether energy use options are likely to exist.

Table 5.1. Are There Uses for the Energy Recovered? (USEPA, 1996)

Are there residential areas nearby that could use a supplemental source of fuel?	Yes	No
Are district heating plants nearby that can use medium quality gas?	Yes	No
Are industrial facilities nearby that can use medium quality gas?	Yes	No
Are there medium-quality gas distribution networks?	Yes	No
Are high-quality gaseous fuels very costly, making gases processing potentially cost effective?	Yes	No
Are there electric power distribution systems that do (or can) obtain power from projects such as landfills?	Yes	No
Would you consider gas recovery as a lost-cost alternative approach for reducing methane emissions even if it is not profitable in its own right?	Yes	No
If the answer is <b>YES</b> to any of the above questions, the energy use criterion is satisfied - for initial screening purposes		

## 5.1. "Large" Landfills and Open Dumps

The most attractive emissions reduction opportunities will be at "large" landfills and open dumps, which are defined as having over 1 million tons of waste in place. Facilities these sizes are expected to generate enough gas to support a profitable gas recovery project over a number of years. Additionally, a majority of the waste tonnage should be less than 10 years old.

There is no single simple approach for assessing whether any candidate landfills or open dumps have enough waste to support a recovery project. Disposal records are often incomplete or nonexistent and can be very time consuming to review, particularly in the context of this initial assessment. Nevertheless, before proceeding to a more in-depth analysis of gas recovery options, a determination should be made that the candidate landfills and open dumps are likely to be large enough to warrant attention. Several alternative approaches are presented which may be used to make this determination.

### 5.1.1. Obtain Individual Landfill Information

Individual landfill information can be obtained through a survey of officials responsible for urban waste management. It is expected that most developing countries and countries with economies in transition will have a relatively small number of large landfills and open dumps, so that the survey of these officials may be relatively modest in size and scope. A telephone or written survey could be used.

To conduct the survey, the relevant officials would be asked to estimate the waste in place at the largest facilities in their areas. Some landfills, especially old ones, may not have the records required for the officials to make these estimates. Alternative approaches for estimating the waste quantity at individual landfills and open dumps are as follows:

- **Area, Depth, and Waste Density**

An estimate of the amount of waste in place can be made from the volume of the site and typical waste placement density. Data on the area and depth of a landfill can be

gathered by a site visit. The density of uncompacted domestic waste as delivered to the site will be in the range of 200 to 400 kg/m<sup>3</sup>. This will rise upon placement to approximately 600 kg/m<sup>3</sup> (excluding cover), or, on average, 800 kg/m<sup>3</sup>. This may rise further on compaction and settlement to 1000 to 1200kg/m<sup>3</sup>.

- **Waste Records**

Landfills may have records of the amount of waste disposed. The records are usually kept on site at the gate by the gate clerks. The landfill supervisor uses this information to compile daily and monthly statistics regarding volumes, waste types, and sources. If such data is available since the year the landfill opened, the amount of waste in place could be estimated from these data. Alternatively; the person(s) responsible for monitoring or dumping waste in the landfill (e.g., gate clerks or landfill supervisors) could provide the rough estimates or recommend alternative approaches. Other, more creative ways can be adopted to determine waste volumes. For example, a landfill in Ankara (Turkey), determined the amount of waste in place using trucking records. Data on the frequency of waste disposal by trucks, obtained from the trucking records, were used along with truck capacity to estimate total waste in place at the landfill.

- **Contour Plots**

A before and after land filling contour plot of the landfill terrain would provide an estimate of the amount of waste in the landfill. Surface topographical maps or aerial snapshots of the site are common techniques of contour mapping. The main drawback of this technique is that a before land filling contour plot of the site is usually not available, especially for old sites (USEPA, 1996).

### **5.1.2. Estimate Average Landfill Size**

This approach relies on determining the average landfill size for a given urban area from the total amount of waste in landfills and the number of landfills in the area. It is recommended that analysis be performed for each urban area; rural areas are excluded as landfills and large open dumps are found primarily in urban areas.

The concept behind this approach is that the total amount of municipal waste generated in the urban area annually can be estimated from the total population. The portion of this waste that was placed in landfills or large open dumps is estimated, to give an assessment of the total waste in place to date. The average landfill or open dump size is estimated as the total waste divided by the number of facilities. Clearly, this is a very approximate method for screening purposes only. The steps are as follows:

#### Step 1: Estimate Total Waste Landfilled

If this data is not readily available for urban areas, a rough assessment of waste in place can be determined using the following data: urban populations; waste generation rate per person per year; fraction of waste landfilled; and the number of years landfilling has been taking place.. The amount of waste land-filled annually for an urban area is the population times the waste generated per person times the fraction of the waste that goes into landfills or large open dumps. This estimate of the annual waste landfilled (tons/yr) is multiplied by the number of years of landfilling to arrive at total waste landfilled (tons).

- **Urban Population**

It is expected that data on urban population will be readily available. The growth rate of urban populations is required to take into account changes in the population structure over the period of landfilling.

- **Waste Generation and Fraction of Landfilled Waste**

Data of waste generation per capita and portion landfilled are generally available from officials responsible for local waste management. Default estimates can be used if needed, although values can vary significantly depending on local conditions. Default values for waste generation and fraction of landfilled waste are presented in Table 5.2.

Table 5.2. Waste Disposal and Waste Generation (USEPA, 1996)

REGION	WASTE LANDFILLED (%)	ANNUAL WASTE GENERATION (KG/CAPITA)
Eastern Europe	85	220
Developing Countries	80	182

- **Years of Land filling**

To estimate total waste in place, an approximate estimate is needed of the number years during which waste has been disposed in landfills and large open-dumps. In large urban areas, such practices have generally been common for at least the last 10 to 20 years. Contacts among officials responsible for local waste management will be able to provide a better figure.

Using this information, the total amount of waste placed in landfills and large open dumps is calculated as follows (USEPA, 1996):

$$\begin{aligned} \text{Total Waste Landfilled (tons)} = \\ \text{Urban Population} \times \text{Waste Generation Rate (kg/person/yr)} \times \text{Fraction of Waste in Landfills} \\ \text{or Open Dumps} \times \text{Years of Landfilling (yr)} \times 0.001 \text{ ton/kg} \end{aligned} \quad (5.1)$$

If we use this formula to Istanbul and Bursa we get 0,788 and 0,556 fraction of waste rate respectively.

Step 2: Determine the Number of Landfills

An approximate number of landfills and large open dumps in each urban area is required. Again, this information is generally available from officials responsible for local waste management.

### Step 3: Calculate the Average Landfill Size

The amount of waste in landfills is determined by dividing amount of waste in landfills by the number of landfills.

$$\text{Average Landfill Size (tons)} = \frac{\text{Total Waste Landfilled (tons)}}{\text{Number of Landfills}} \quad (5.2)$$

This method will indicate whether the urban population in each city disposes of enough waste annually in landfills and open dumps to support gas recovery projects. Clearly, the assessment is crude in that it does not investigate the actual disposal histories at specific sites. Additionally, all the landfills and open dumps are assumed to share equal amounts of waste. If facility sizes vary considerably, the average size may not be a good indicator of whether gas recovery projects are likely to be attractive. Nevertheless, if the result of this rough estimate is an average waste figure greater than 1 million tons, there is likely to be at least 1 landfill which meets the criterion (USEPA, 1996).

#### **5.1.3. Estimate the Number of People Per Landfill or Open Dump**

This approach addresses the question in reverse: how many people are required to support a landfill with 1 million tons of waste. Using this estimate, urban areas with populations that are below this cutoff can be eliminated from further consideration.

##### Step 1: Estimate the Number of People Required Per Landfill or Large Open Dump

The number of people required is estimated by dividing 1 million tons by: waste generation per capita per year; portion of waste placed in landfills or open dumps; and number of years of disposal in landfills and open dumps. For example, using the default values for developing counties in Table 5.2 above, and assuming waste disposal for 10 years, a population of about 690,000 is required to support a single landfill.

$$\begin{aligned}
 & \text{Number of People per Landfill or Open Dump=} \\
 & \text{Waste per Landfill or Open Dump (e.g., 1 million tons) / [ Waste Generation Rate} \\
 & \quad (\text{kg/person/yr}) \times \text{Fraction of Waste in Landfills or Open Dumps} \times \\
 & \quad \text{Years of Landfilling (yr)]} \qquad \qquad \qquad (5.3)
 \end{aligned}$$

#### Step 2: Identify Candidate Cities

Given the cutoff population estimate, those cities with populations above the cutoff are identified from census information.

#### Step 3: Review Candidate Cities

Once the candidate cities are identified, each should be reviewed to obtain better city-specific information on waste generation and disposal practices. In particular, the presence of multiple landfills or large dumps should be explored to assess whether the average population per facility is large enough to support a 1 million ton site.

Based on the results of one or more of these three options, a determination is made as to whether there are landfills or open clumps large enough to warrant further analysis (USEPA, 1996).

#### **5.1.4. Waste Characteristics**

Waste characteristics influence both the amount and the extent of gas production within landfills. MSW contains significant quantities of degradable organic matter. The decomposition (fermentation) of this organic material leads to methane emissions. Different countries and regions are known to have MSW with widely differing compositions: wastes from developing countries are generally high in food and yard wastes, whereas developed countries, especially North America, have a very high paper and cardboard content in their MSW. Landfills in developing countries will tend to produce gas quickly (completing methane production within 10-15 years) because putrescible material decomposes rapidly. Landfills with a high paper and cardboard content will tend to produce methane for 20 years or more, at a lower rate.

Landfills with MSW are good candidates for gas recovery projects. If hazardous materials are mixed with the MSW, the recovered gas may contain trace quantities of hazardous chemicals which should be removed from the gas prior to utilization. Higher gas purification requirements translate to higher costs.

If landfills or large open dumps primarily have large quantities of construction and demolition debris, they will not produce as much gas as would otherwise be expected. Therefore, these sites may not be good candidates for gas recovery.

As a final step, the waste types contained in the promising facilities identified in the previous steps should be assessed. As discussed above, disposal records are often incomplete or nonexistent. Consequently, unless a special study has been undertaken for a specific city or facility, it is unlikely that good data are readily available regarding waste composition in landfills and open dumps. To undertake this initial assessment, it is recommended that officials involved with the operation of the major facilities under consideration be contacted to discuss whether degradable MSW is a significant portion of the waste landfilled and whether hazardous materials might have been disposed of at the site (USEPA, 1996).

## **5.2. Initial Appraisal Results**

Using the information from the above four steps, the initial appraisal can be performed. Table 5.3 lists the questions addressed by the four steps. If each of the four questions listed in the exhibit can be answered "Yes," there are likely to be good opportunities for reducing methane emissions through the implementation of gas recovery projects.

Even if one or more questions cannot be answered "Yes," there may be attractive opportunities for reducing emissions under certain circumstances. The following conditions would favor gas recovery from landfills:

- **Energy Shortage**

In areas of acute energy shortage, a gas recovery project may be highly desirable as a source of provides energy for the local area. In such cases, the profitability of a gas recovery project is better evaluated in terms of the value of energy recovery per household rather than a cost-revenue comparison.

- **High Energy Cost**

A high cost of alternative fuels, especially natural gas, would favor gas recovery projects. In such high cost environments, smaller sites (e.g., 500,000 to 1 million tons of waste) would, potentially support profitable gas recovery projects.

- **Marginal Upgrading Cost**

Some facilities may already have gas collection systems in place to prevent off-site gas migration. These collection systems may be required to ensure the safe operation of the facility. At these facilities, the marginal cost of installing a utilization system might, be small. In some cases, the collection system might require upgrading to maximize recovery of gas generated. Even small landfills would be potential candidates for gas recovery in such cases.

Finally, as discussed above, it may be desirable to recover and combust methane from landfills and open dumps even if they do not meet the criteria listed above. In particular, even if there is no opportunity to use the gas for energy, methane emissions can be reduced at relatively low cost by simply collecting and flaring the gas. Such projects may be attractive to investors in developed countries who are identifying low-cost options for reducing greenhouse gas emissions through joint international action (USEPA, 1996).

Table 5.3. Initial Appraisal Results Checklist (USEPA, 1996)

Are there landfills or large open dumps (currently receiving waste or closed recently) that could be potential candidates?	Yes	No
At the potential candidate sites, are there potential uses for the energy recovered?	Yes	No
Do the candidate sites have at least 1 million tons of waste in place?	Yes	No
Do the candidate sites contain primarily Municipal Solid Waste?	Yes	No
If the answer is YES to all of the above questions, there are promising options for gas recovery.		

### 5.3. Potential Gas Production

Before a gas recovery project can be considered at a landfill site, an estimate is needed of the current and potential future amount of gas that can be produced. The amount of gas that can be collected depends on several factors, including, among others, the amount of waste in place, waste characteristics, and facility and collection system designs.

There are three estimation procedures that can be used. To conduct a preliminary assessment, a rough approximation method is presented that does not require specific information regarding waste characteristics. More detailed modeling approaches are presented that can be tailored to site-specific conditions. Each of these methods is described in turn.

### 5.3.1. Method 1: Test Wells

The most reliable method for estimating gas quantity/short of installing a full collection system is to drill test wells and measure the gas collected from these wells. To be effective, the wells must be placed in representative locations within the site. Individual tests are performed at each well to measure gas flow and gas quality. The number of wells required to predict landfill gas quantity will depend on factors such as landfill size and waste homogeneity.

A general rule applied by landfill developers in developing countries and countries with economies in transition to estimate the rate at which a sustainable gas yield can be drawn from a site using test wells is to cut in half the amount of gas collected by test wells. This is done because wastes at these sites are often loosely compacted or spread in varying amounts across the landfill. Also, gas migration at these sites is a common problem which can bias gas collection figures upward. Furthermore, cutting the test estimates in half provides a conservative estimate of gas production, which is important for purposes of determining the size of the energy recovery system. Later, if it is determined that the gas is being under-utilized, it is easy to supplement the collection system; however, the reverse is not true.

An added benefit of this method is that the collected gas can be tested for quality as well as quantity. The gas should be analyzed for methane content as well as hydrocarbon, sulfur, particulate, and nitrogen content. This will help in designing the processing and energy recovery system (USEPA, 1996).

### 5.3.2. Method 2: Rough Approximation

The simplest method of estimating the gas yield from a landfill site is to assume that each ton of waste will produce 6 m<sup>3</sup> of landfill gas per year. The procedure for approximating gas production is derived from the ratio of waste quantity to gas flow observed in the many diverse projects already in operation. It reflects the *average* landfill that is supporting an energy recovery project, and may not accurately reflect the waste, climate, and other characteristics present at a specific landfill.

This rough approximation method only requires knowledge of how much waste is in place at the target landfill or large open dump. The waste tonnage should ideally be less than 10 years old. Estimates from this approximation should be bracketed by a range of plus or minus 50%. This rate of production can be sustained for 5 to 15 years, depending on the site

### 5.3.3. Method 3: Model Estimates

Although test wells provide real data on the site's gas production rate at a particular time, models of gas production predict gas generation during the site filling period and after closure. These, models typically require the period of land filling, the amount of waste in place, and the types of waste in place as the minimum data. Two main models used for emissions estimating purposes are the "LandGem Model" and the "Tabasaran/Rettenberger model."

The "LandGem Model" accounts for changing gas generation rates over the life of the landfill. The model, therefore, takes into account the various factors which influence the rate and extent of, gas generation. The model requires that the following five variables be known or estimated:

- the average annual waste acceptance rate;
- the number of years the landfill has been open;
- the number of years the landfill has been closed, if applicable;
- the potential of the waste to generate methane; and
- the rate of methane generation from the waste.

The basic LandGem Model is as follows:

$$LFG = L_o * R (e^{-kc} - e^{-kt}) \quad (5.4)$$

where:

- LFG: Total amount of landfill gas generated in current year (m<sup>3</sup>/year)  
 L<sub>0</sub>: Total methane generation potential of the waste (m<sup>3</sup>/ton)  
 R: Average annual waste acceptance rate during active life (tons)  
 k: Decay constant for the rate of methane generation (1/year)  
 t: Time since landfill opened (years)  
 c: Time since landfill closure (years)

The methane generation potential, L<sub>0</sub>, represents the total amount of methane that one kilogram of waste is expected to generate over its lifetime. The decay constant, k, represents the rate at which the methane will be released from each kilogram of waste. If these terms were known with certainty, the first order decay model would predict landfill gas generation relatively accurately; however, the values for L<sub>0</sub> and k are very widely, and are difficult to estimate accurately for a particular landfill.

Ranges for L<sub>0</sub> and k values developed by an industry expert are presented in Table 5.4. Since these values are dependent in part on local climatic conditions and waste composition, it is recommended that others in the local area with similar landfills who have installed gas collection systems be consulted to narrow the range of potential values. Note that for different climatic conditions, the L<sub>0</sub> (total amount of landfill gas generated) remains the same, but the k value (rate of landfill gas generation) changes, with dry climates generating gas more slowly. Because of the uncertainty in estimating k and L<sub>0</sub>, gas flow estimates derived from the LandGem model should also be bracketed by a range of plus or minus 50 per cent (USEPA, 1996).

The " Tabasaran/Rettenberger " was developed from data on gas recovery projects in the United States. This model relates gas production to the quantity of waste in the facility.

The Tabasaran/Rettenberger model can be described mathematically by;

$$G_t = 1.868 * C_{org} * (0.014T + 0.28) * (1 - 10^{-kt}) \quad (5.5)$$

where

$G_t$	= LFG gas production at a given time, (m <sup>3</sup> /ton)
$G_{org}$	= organic carbon content (kg/ton)
$T$	= temperature (°C)
$k$	= degradation rate constant (year <sup>-1</sup> )
$t$	= elapsed time since first depositing (year)

This model was specified only for large landfills with at least one million tons of waste in place. As indicated in the equation, the degradation coefficient is reduced when the landfill is located in an arid region.

It should be noted that not all landfill gas generated in the landfill can be collected. Some of the gas generated in a landfill will escape through the cover of even the most tightly constructed and collection system. Newer systems may be more efficient than the average system in operation today. A reasonable assumption for a new collection system that will be operated for energy recovery is 70 - 85% collection efficiency. The estimates from the LandGem Model and the Tabasaran/Rettenberger model should be multiplied by this range of collection efficiencies (70-85%) to determine the potential collectable gas from the site (USEPA, 1996).

## **6. GAS RECOVERY AND UTILIZATION**

### **6.1. Gas Recovery Technologies**

To recover gas from a landfill or large open dump, vertical or horizontal wells, are drilled into the waste where methane is being produced. The wells are connected by horizontal piping to a central point where a blower removes gas under negative pressure. Recovery systems are usually operated as part of an overall gas control system. A typical gas recovery system generally includes a backup flare. This section provides a brief overview of each component, and outlines the major characteristics of energy recovery systems that determine their applicability at a given site.

Typical landfill gas collection systems have three main components: collection wells; a blower (compressor); and a flare for use when gas production exceed gas use

#### **6.1.1. Gas Collection Wells**

Gas collection typically begins after a portion of a facility (e.g., a landfill cell) is closed. There are two collection system configurations: vertical wells and horizontal wells. Vertical wells, shown in Figure 6.1, are by far the most common, type of well used for gas collection. Horizontal wells may be appropriate for landfills which need to recover gas promptly (e.g., landfills with gas migration problems). Regardless of whether vertical or horizontal wells are used, each wellhead is connected to lateral piping, which transports the gas to a main collection header. Ideally, the collection system should be designed so that the operator can monitor and adjust the gas flow if necessary (USEPA, 1997).

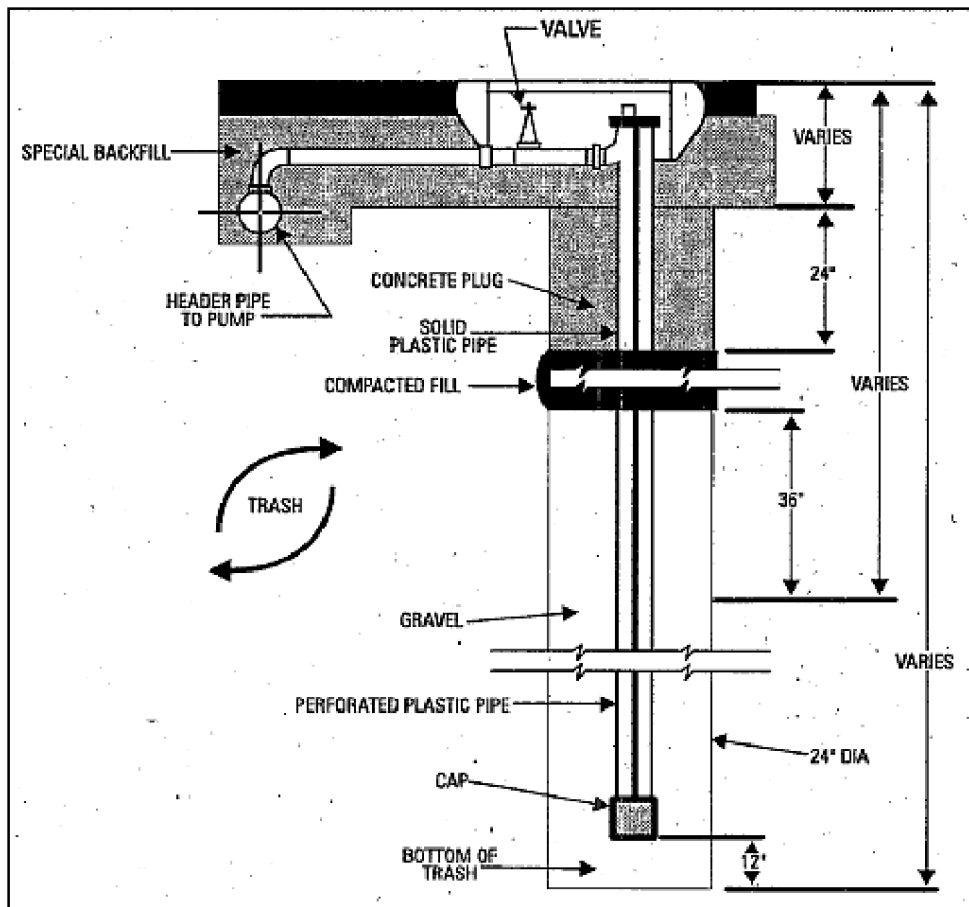

Figure 6.1. Typical Gas Collection Well (USEPA, 1997)

### 6.1.2. Blower

A blower (or compressor) provides the negative pressure to pull the gas from the collection wells into the collection header. The size, type, and number of blowers needed to withdraw the gas from the landfill, or open dump depends on the gas flow rate. Additional gas compression may be required depending on how the gas is used. However, the amount of compression required solely for withdrawing the gas from the facility is generally quite small because only a slight negative pressure is required. For example, a facility with 2 million tons of waste may produce about 15 million  $\text{m}^3$  of gas per year, or about 28.5  $\text{m}^3$  per minute. Given that about 0.3 to 0.8 horsepower (hp) is required per  $\text{m}^3/\text{min}$  of gas flow, total blower hp requirements are only about 36 to 95 hp.

### 6.1.3. Flare

A flare burns the recovered gas when it cannot be used. The gas will readily form a combustible mixture with air, and requires only an ignition source to ensure combustion. The flame can burn openly or can be enclosed.

- **Open Flame Flares**

Open flame flares (e.g., candle or pipe flares) are the simplest flaring technology. They consist of a pipe through which the gas is pumped, a pilot light to spark the gas, and some means of regulating the gas flow. Possible complications include unstable flames leading to inefficient combustion, aesthetic complaints, and the difficulty of testing emissions from open flames. Some open flame flares are covered, both hiding the flame from view and allowing relatively accurate monitoring for low flow rates. Figure 6.2 presents a diagram of a typical open flare.

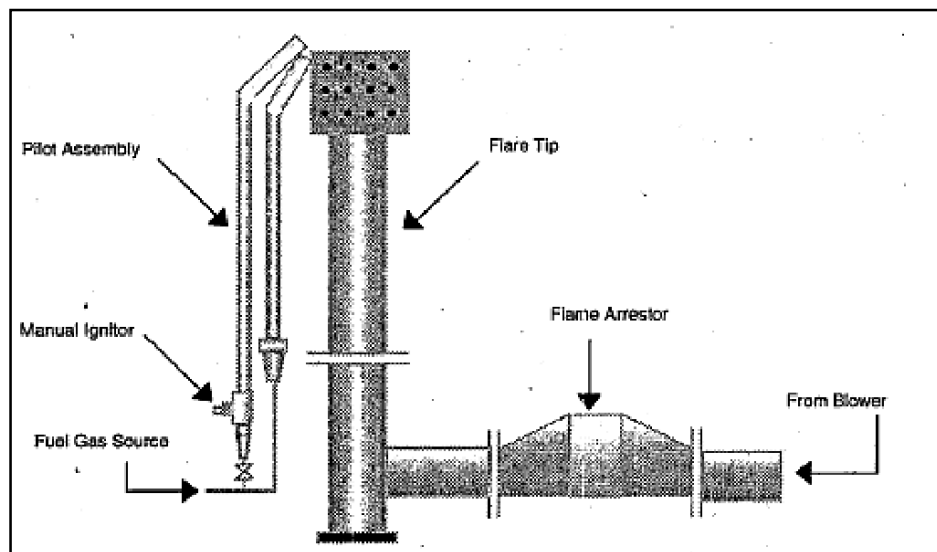

Figure 6.2. Typical Open Flare (USEPA, 1997)

- **Enclosed Flares**

Enclosed flares are designed to overcome the problems associated with open flame flares. Because the air flow can be adjusted, the combustion is more reliable and more efficient. As a result, unburned hydrocarbon and hazardous material emissions are reduced. However, these flares cost several times more than the open flame flares.

Most energy recovery systems will have flares to remove excess gas whenever required. Flaring may also be considered as the principal emissions control strategy for situations in which gas utilization is not appropriate.

These three components must be used to recover the gas. In order for gas recovery to be technically feasible, the facility must be able to sustain the drilling of wells. The waste into which the wells are drilled must be relatively stable, and cannot be saturated with water. Some facilities have impermeable barriers below (such as clay liners) which trap water. If this water is not removed via a leachate collection system, the waste can be cone saturated and unable to sustain gas recovery wells. Test wells can be used to verify that the waste can support gas recovery wells (USEPA, 1997).

## **6.2 Gas Utilization Technologies**

Methane recovered from landfills and large open dumps can be used in a variety of applications. The selection of which option to use depends first on the requirements for energy on-site and in the surrounding area. Once these needs are identified, the most attractive options will be those that are compatible with the quantity and quality of gas that can be produced at the facility.

Concentration of CH<sub>4</sub> over 25% only is worth extracting for energy production. A typical LFG (landfill gas) has CH<sub>4</sub> concentration of 50%. The LFG could be utilized directly for heating, as medium-heating value gas (raw gas), high heating value gas (filtered gas) and also for power generation in IC (internal combustion) engines, and in gas and steam turbines. However, the most economic option is the direct use for process heating and boiler fuel (Kumar, 2000).

### **6.2.1. Local Gas Use**

The simplest option for using the recovered gas is local gas use. This option requires that the gas be transported, typically by a dedicated pipeline, from the point of collection to the point(s) of gas use. If possible, a single point of use is preferred so that pipeline construction and operation costs can be minimized.

Prior to transporting the gas to the user, the gas must be cleaned to some extent. Condensate and particulates are removed through a series of filters and/or driers. Following this minimal level of gas cleaning, gas quality of 35 to 50 per cent methane is typically produced. This level, of methane concentration is generally acceptable for use in a wide variety of equipment, including boilers and engines. Although the gas use equipment is usually designed to handle natural gas that is nearly 100 per cent methane, the equipment can usually be adjusted easily to handle the gas with the lower methane content.

To assess the feasibility of this option, countries need to estimate the length of the pipeline needed to transport the gas to the potential user. As discussed above, distances over about 3 km are typically not cost effective. Additionally, there must be a path along which the pipeline can be constructed. Barriers such as rivers or excessively hilly terrain can make pipeline installation prohibitively costly. For each potential local use option, estimate the pipeline length required by visiting the site and driving or walking the path that the pipeline could follow. Alternatively, local maps could be used to estimate these items (USEPA, 1996).

### **6.2.2. Electricity Generation**

Electricity can be generated for on-site use or for distribution through the local electric power grid. There are several available technologies for generating electricity: internal combustion engines (ICs) and gas turbines are the most commonly used prime movers for landfill gas energy recovery projects.

The anticipated landfill gas flow rate is particularly important in choosing an appropriate prime mover to generate electricity. Gas turbines typically require higher gas flows than IC engines to make them economically attractive. Therefore, gas turbines are generally suitable only for large landfills. Additionally, gas turbines are expected to run relatively constantly, and as a consequence are not turned on and off to match changing electricity loads during the day. Consequently, gas turbines are commonly used to generate electricity that will be distributed through the electric power grid on a continuous basis. IC engines can more easily be turned on and off, and are therefore suitable for supplying

intermittent on-site power needs as well as distribution through the grid. Comparison of Internal Combustion Engines and Gas Turbines is given in Table 6.1.

Table 6.1. General Comparison of Gas Turbine and Internal Combustion Engines (USEPA, 1996)

Consideration	More Advantageous System	
	Gas Turbines	Engines
Size options available		X
Capital Cost		X
O&M cost	X	
Energy efficiency and revenue		X
Overall cost		X
Resistance to corrosion	X	
Air emission	X	
Need for specialized maintenance		X
Need for operations attention	X	

- **Internal Combustion Engines**

Internal combustion engines are the most commonly used conversion technology in landfill gas applications. They are stationary engines, similar to conventional automobile engines that can use medium quality gas to generate electricity. While they can range from 30 to 2000 kilowatts (kW), IC engines associated with landfills typically have capacities of several hundred kW.

IC engines are a proven and cost-effective technology. Their flexibility, especially for small generating capacities, makes them the only electricity generating option for smaller

landfills. At the start of a recovery project, a number of IC engines may be employed; they may then be phased out or moved to alternative utilization sites, as gas production drops.

IC engines have proven to be reliable and effective generating devices. However, the use of landfill gas in IC engines can cause corrosion due to the impurities in landfill gas. Impurities may include chlorinated hydrocarbons that can react chemically under the extreme heat and pressure of an IC engine. In addition, IC engines are relatively inflexible with regard to the air:fuel ratio, which fluctuates with landfill gas quality. Some IC engines also produce significant NO<sub>x</sub> emissions, although designs exist to reduce NO<sub>x</sub> emissions.

- **Gas Turbines**

Gas turbines can use medium quality gas to generate power for sale to nearby users or electricity supply companies, or for on-site use. Gas turbines typically require higher gas flows than IC engines in order to be economically attractive, and have therefore been used at larger landfills; they are available in sizes from 500 kW to 10 MW, but are most useful for landfills when they are 2 to 4 MW. Also, gas turbines have significant parasitic loads: when idle (not producing power), gas turbines consume approximately the same amount of fuel as when generating power. Additionally, the gas must be compressed prior to use in the turbine (USEPA, 1996).

### **6.2.3. Pipeline Injection**

Pipeline injection may be a suitable option if no local gas user is available. If a pipeline carrying medium quality gas is nearby, only minimal gas processing may be needed to prepare the gas for injection. Pipeline injection requires that the gas be compressed to the pipeline pressure.

- **Medium Quality Gas**

Medium quality gas will typically have an energy value that is the equivalent to landfill gas with, a 50 per cent methane concentration. Prior to injection, the gas must be processed so that it is dry and free of corrosive impurities. The extent of gas compression

and the distance required to reach the pipeline are the main factors affecting the attractiveness of this option.

- **High Quality Gas**

For high-quality gas, most of the carbon dioxide and trace impurities must be removed from the recovered gas. This is a more difficult and hence more expensive process than removing other contaminants. Technologies for enriching the gas include pressure swing adsorption with carbon molecular sieves, amine scrubbing, and membranes.

To assess the feasibility of pipeline injection, you need to determine the locations of the pipelines and their gas quality specifications. As with the other options, the closer the pipeline the better. Additionally, the availability of capacity in the pipeline to carry the additional gas being produced must also be assessed. A Summary of technical feasibility of utilization options for landfill gas shown in Table 6.2 (USEPA, 1996).

Table 6.2. Summary of Technical Feasibility of Utilization Options for LFG (USEPA, 1996)

<b>Utilization Option</b>	<b>Minimum Amount of Waste in Place<sup>5</sup></b>	<b>Gas Quality (Min. CH<sub>4</sub> Concentr.)</b>	<b>Applicability</b>
<b><i>Local Gas Use</i></b>			
Direct use on site or off site (nearby) in industrial, residential or commercial facilities	1 Million tons	35%	Off-site facility should be within 3km of the site. On-site usage should be suitable with sites with large energy requirements, especially those that already use natural gas
<b><i>Electricity Generation</i></b>			
IC Engines	1,5 Million tons	40%	Electricity grid required; electricity sold must be compatible with user's equipment. On-site usage suitable for site with auxiliary equipment required electricity.
Gas Turbines	2 Million tons	40%	Electricity grid required; electricity sold must be compatible with user's equipment. On-site usage suitable for site with auxiliary equipment required electricity.
<b><i>Pipeline Injection</i></b>			
Medium Quality Gas Pipelines	1 Million tons	30 to 50%	A medium quality gas pipeline network must be accessible and must have the capacity to carry the gas.
High Quality Gas Pipelines	1 Million tons	95%	Extensive gas processing is required and a high quality gas pipeline network must be accessible and must have the capacity to carry the gas.
<b><i>Other Options</i></b>			
Flaring	Applicable for all landfill sizes	20%	Applicable of landfills of all sizes.

<sup>5</sup> Amount of waste in place should be less than ten years old. If the waste is freshly placed, options can be favorable waste tonnage greater than 500,000 tons.

## **7. ISTANBUL-KEMERBURGAZ LANDFILL GAS TO ENERGY PROJECT**

### **7.1. Introduction**

Landfill gas could pose safety and health concerns to human species and environment because of the flammable and explosive characteristic if not adequate landfill gas management system is carried out in the landfill site. In order to eliminate of such a risk, the landfill gas might be collected with suitable techniques and destroyed in the flare(s). It can also be destroyed in the gas engines to generate electricity and heat or can be purified in order to use as a natural gas.

In this framework two Landfill Gas to Energy projects have been initiated in the landfill sites both European and Asian Side of Istanbul. 32.000.000 tons of wastes in place in Odayeri Landfill Site and electrical capacity of LFG facility would be 25MW for the first stage. Similarly, 15.000.000 tons of waste in place in K m rc oda Landfill Site and electrical capacity of LFG facility would be 10MW for the first stage. Both landfill gas to energy project's infrastructure have been done and started to generate electricity (Kiriş and Saltabaş, 2009).

Due to the similar technologies both of them have, it has been evaluated the larger one, Kemerburgaz Project, to become an illustration to the municipalities out of town. Before getting into details of project it may be helpful to mention about city of Istanbul to form an opinion about its potential as a metropolis.

### **7.2. Metropolis Istanbul**

#### **7.2.1. Geography**

Istanbul is located in the north-west Marmara Region of Turkey. It encloses the southern Bosphorus which places the city on two continents—the western portion of Istanbul is in Europe, while the eastern portion is in Asia. The city boundaries cover a surface area of 1,830.93 square kilometers, while the metropolitan region, or the Province of Istanbul, covers 6,220 square kilometers.

### 7.2.2. Climate

Istanbul has a temperate climate but is located within a climatic transition zone between oceanic and Mediterranean.

Summer is generally hot and humid, the temperature between July and August averaging 28 °C (82 °F). Winter is cold, wet and often snowy, averaging 5 °C (41 °F). Spring and autumn are usually mild and wet but are erratic, and the weather can range from chilly to warm, though the nights are chilly.

The humidity of the city is constantly high which makes the air feel much harsher than the actual temperatures. The city being located in the second most humid region of the country, has an average annual humidity of 72%. Average annual precipitation is 781 mm (33 in), (DSI). Istanbul has an average annual of 152 days of precipitation. Summer is the driest season, but precipitation does occur during that season and is irregular and often torrential.

Table 7.1. Climate data for Istanbul (Turkish State Meteorological Service)

ISTANBUL	Jan.	Feb.	Mar.	Apr.	May	Jun.	Jul.	Aug.	Sep.	Oct.	Nov.	Dec.
Average Values (1975 - 2008)												
Average temp. (°C)	6.1	5.9	7.7	12.1	16.7	21.5	23.8	23.5	20.0	15.6	11.2	8.0
Average highest temp. (°C)	9.0	9.2	11.6	16.6	21.3	26.2	28.5	28.3	24.9	19.9	14.8	10.7
Average lowest temp. (°C)	3.6	3.2	4.6	8.3	12.4	16.8	19.4	19.5	16.0	12.3	8.3	5.4
Average sunny days (hr)	2.3	3.1	4.6	6.0	8.0	9.8	10.5	9.4	7.9	5.2	3.3	2.2
Average precipitation days	17.3	14.9	13.0	11.3	7.6	6.4	3.9	5.6	7.0	11.3	13.7	16.9
Average precipitation (kg/m <sup>2</sup> )	83.9	64.9	58.8	45.3	30.2	25.7	24.7	31.8	35.9	72.4	89.6	101.3
Highest and Lowest Values (1975 - 2009)*												
Record high (°C)	18.3	24.0	26.2	32.9	33.0	40.2	39.7	38.8	33.6	34.2	27.2	21.2
Record low (°C)	-7.9	-8.0	-6.9	0.6	3.6	9.0	13.5	12.2	9.2	3.2	-1.0	-3.4

### **7.2.3. Demography**

The population of the metropolis more than tripled during the 25 years between 1980 and 2005. Roughly 70% of all Istanbulites live in the European section and around 30% in the Asian section. Due to high unemployment in the southeast of Turkey, many people from that region migrated to Istanbul, where they established themselves in the outskirts of the city. Migrants, predominantly from eastern Anatolia arrive in Istanbul expecting improved living conditions and employment, which usually end with little success.

The city has a population of 12,915,158 residents according to the latest count as of 2009, and is one of the largest cities in the world today. The rate of population growth in the city is currently at 3.45% a year on average, mainly due to the influx of people from the surrounding rural areas. Istanbul's population density of 2,486 people per square km far exceeds Turkey's 94 people per square km (Turkish Statistical Institute, 2009).

### **7.3. Istanbul Kemerburgaz Sanitary Landfill**

Solid wastes have disposed to sea until 1953 in Istanbul. After that it has started to dispose under insanitary conditions to Levent, Seyrantepe and Ümraniye. In year 1993 a huge methane explosion occurred in Ümraniye-Hekimbaşı waste disposal area and nearly 350,000m<sup>3</sup> waste slipped to the Pınarbaşı region. Some of houses damaged and unfortunately 27 people died after this undesirable accident.

As a result of these regardless implementations Municipality of Metropolis Istanbul has developed to manage two integrated solid waste landfill and wastes have begun to dispose there with cell method under sanitary conditions.

After closure of wild disposal in Kemerburgaz in 1995 it has been begun to collect landfill gas to generate electricity. It has been the first application in Turkey. Since then close to 32,000,000 tons waste has been collected professionally. Figure 7.1 and 7.2 shows the amount of annual and cumulative collected waste values respectively.

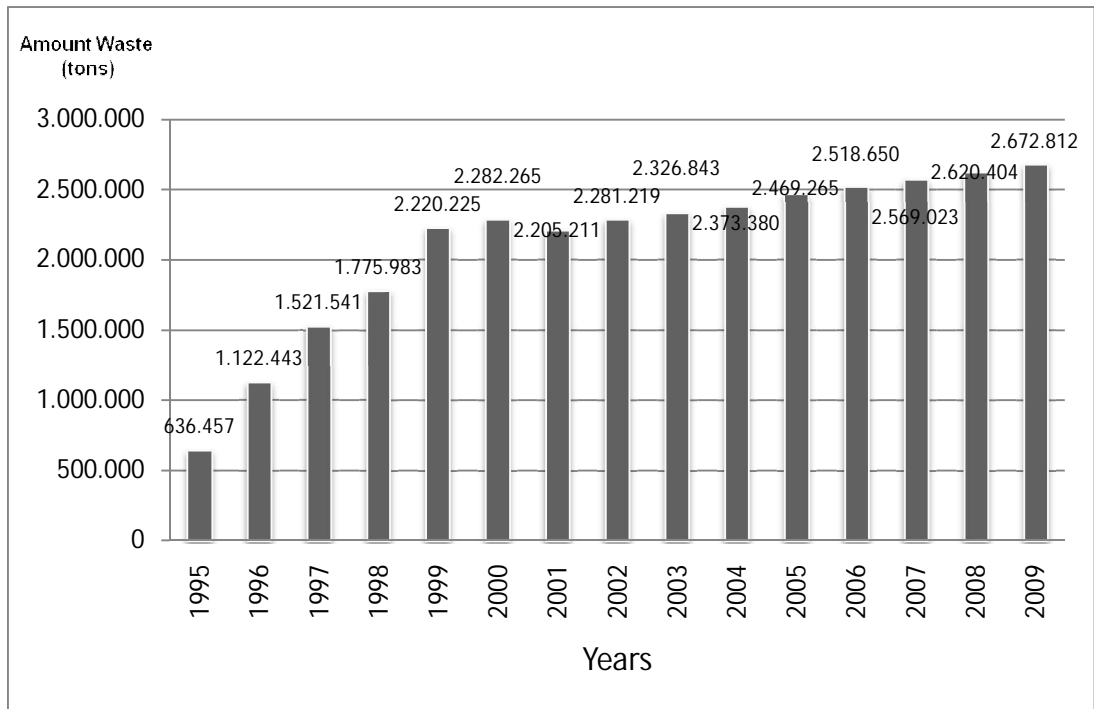

Figure 7.1. Annual solid waste amounts collected in Kemerburgaz Sanitary Landfill (İSTAÇ, 2010)

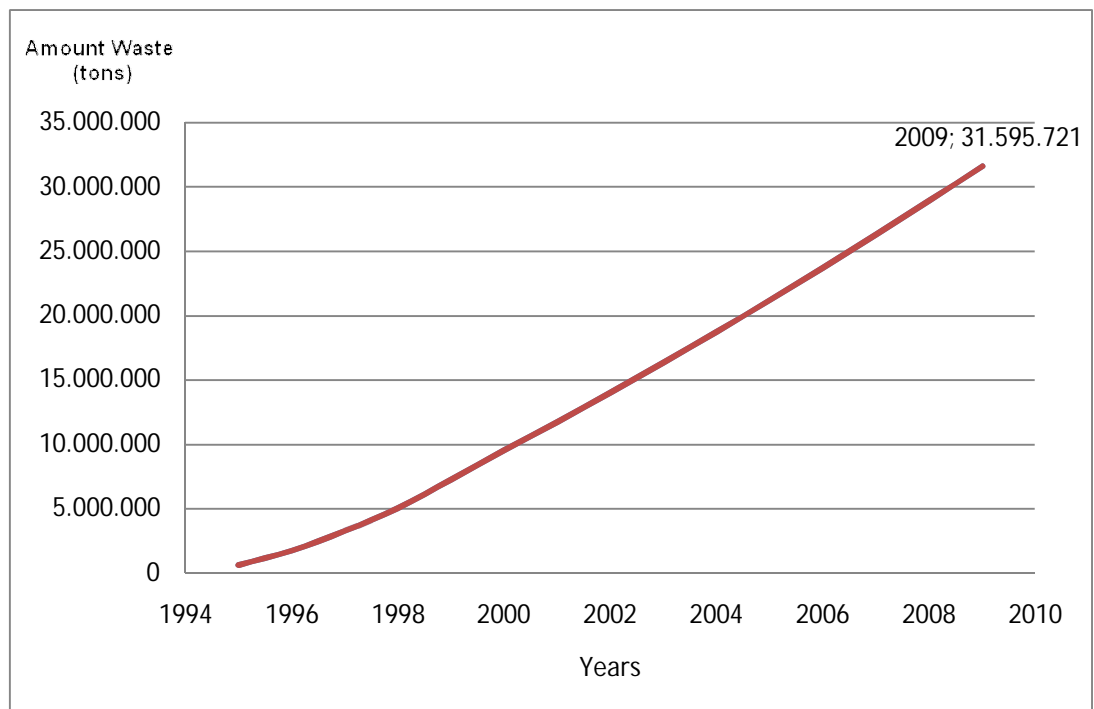

Figure 7.2. Cumulative solid waste amount collected in Kemerburgaz Sanitary Landfill (İSTAÇ, 2010)

### 7.3.1. Design Properties

Kemberburgaz Saniraty Landfill (Figure 7.3) is established in an area of 58 hectares. Up to present 31,595,721 m<sup>3</sup> solid waste landfilled in Kemberburgaz Landfill site. Every day, average of 10,000 tons of solid waste is transported to the site. Wastes filled by Platform System.



Figure 7.3. Kemberburgaz Saniraty Landfill (İSTAÇ, 2010)

There are lots of platform systems which exceed 40 meters. In order to establish surface water drainage canals and landfill gas recovery pipes, slope of site has to be sustained. And it is ensured by benches. When it reaches the most upper landfill is covered by soil then clay cap, top soil and vegetative cover respectively. Cross section of a typical Platform is shown in Figure 7.4 and Figure 7.6.

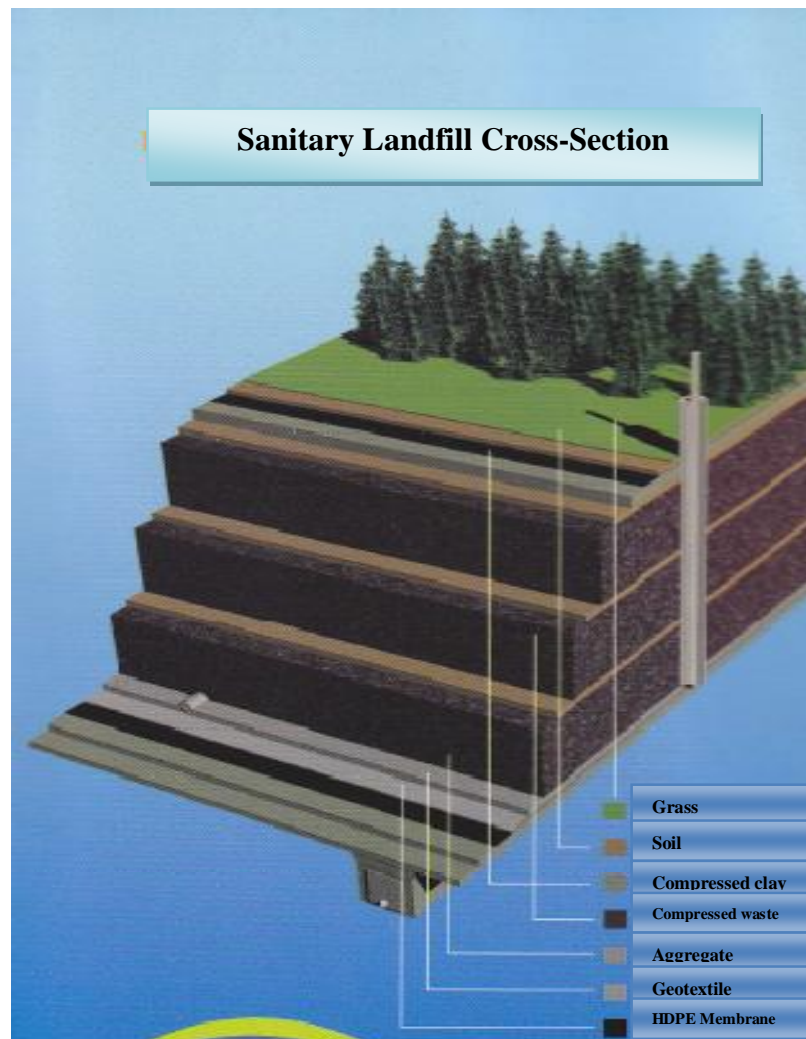

Figure 7.4. Cross section of a typical Platform (İSTAÇ, 2010)

Most important problem of Sanitary Landfill is leachate as an Environmental issue. Leachate is an intensive contaminant for both under and over ground waters. In order to prevent these contaminant factors of leachate basement of landfill has to be impermeable. To obtain this impermeability natural and synthetic materials are used.



Figure 7.5. Impermeable geomembrane spread under landfill (İSTAÇ, 2010)

Vegetative soil layer of landfill site is cleaned and provide underground water drainage. Underground water is drained by drainage channels to the outside of field and ground is compressed again with suitable slope. Each of 15cm two layers impermeable clay lay out and compressed. Two millimeters thick high dense (HDPE) geomembrane (Figure 7.5) and geotextile is lay out upon compressed ground. Impermeable level of geomembrane is  $10^{-9}$  m/sec and 30 kgN/m rupture tension with 2 kPa load resistance.

After these layers leachate collection system is placed. Pipes covered by 30cm, 30 per cent lime at most aggregate. Finally drainage is obtained and gas collection wells with 35-40m effective radius are established.

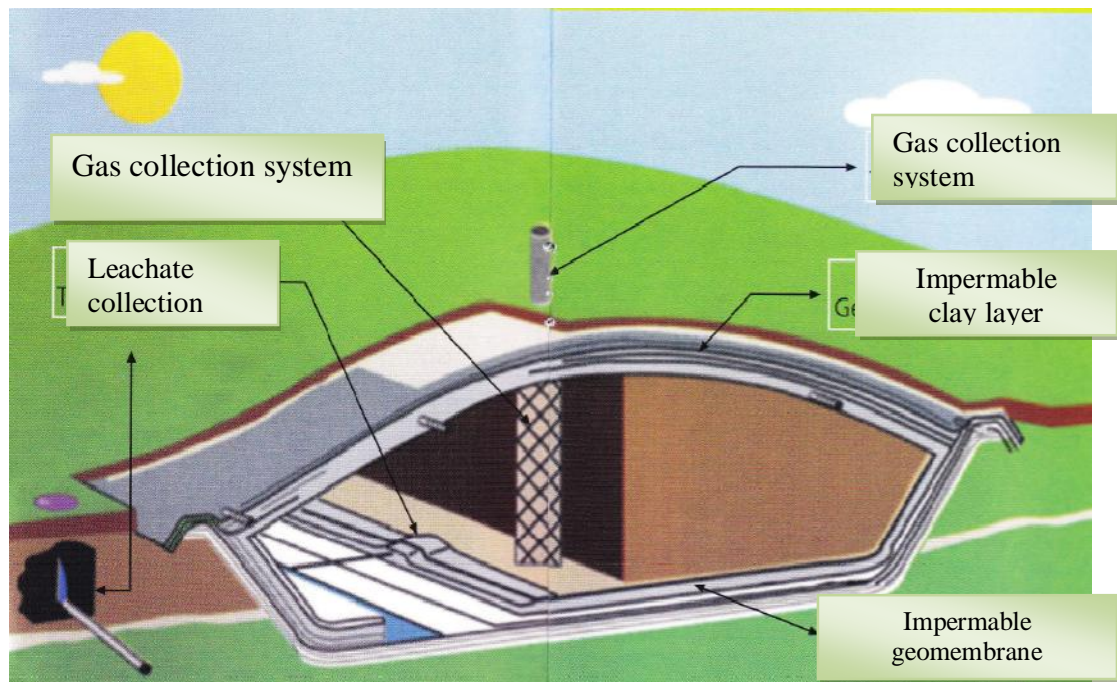

Figure 7.6. Section of Sanitary Landfill (İSTAÇ, 2010)

Compressed waste is closed with impermeable clay. This layer is also compressed and covered with natural soil.

### 7.3.2. Composition of Waste

Composition of waste is extremely important for LFG. As it is mentioned in section four, there are factors affecting landfill gas generation. Some of them are moisture content, bacterial content, pH level, temperature and organic content of waste. Organic waste content may be the most significant of them. Amount of organic content in solid waste is directly affects of methane production as shown in equation 7.1 (Tchobanoglous et al., 1993).

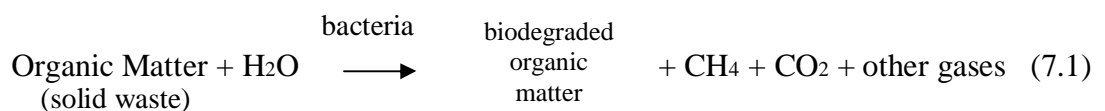

Table 7.2 shows the general properties of solid waste landfilled in Kemerburgaz which is established on area of 58 hectares.

Table 7.2. Composition of Kemerburgaz Sanitary Landfill solid waste (Percentage by wet weight) (İSTAÇ, 2007)

<b>Composition of Solid Waste</b>	<b>Percentage of Wet Weight</b>
Ash	2,0
Organic Matter	55,3
Paper	12,9
Plastic	17,1
Glass	5,3
Textile	3,9
Metal	1,2
Others	2,4

### 7.3.3. Leachate Treatment Plant

The largest leachate treatment plant of EU was established in Kemerburgaz. Approximately 5,000m<sup>3</sup> leachate is refined by the way of Membrane Bioreactor + Nanofiltration technology every day. Treatment plant mainly consists of preliminary settling, Membrane Bioreactor, Nanofiltration and sludge settling units.

First of all leachate is subject to preliminary settling and then supplied to the Membrane Bioreactor to biological treatment. After biological treatment leachate is sent to Ultrafiltration Membrane System which is located in the outside of main plant. Sludge and suspended material is disposed with cross flow UF membranes. Next station is nanofiltration membranes. Rest of organic micro pollutant and heavy metals are purified. Kemerburgaz leachate treatment plant is shown in Figure 7.7.



Figure 7.7. Kemberburgaz Leachate Treatment Plant

In Kemberburgaz sanitary landfill 2400 m<sup>3</sup>/day leachate origins. Collected leachate sends to Leachate Treatment Plant and measures the input and output parameter daily. The parameters have to be consistent with EU environmental standards. Table 7.3 shows the parameters of raw leachate in Kemberburgaz Leachate Treatment Plant.

Table 7.3. Raw leachate properties in Odayeri, Kemberburgaz. (İSTAÇ, 2010)

Parameter	Unit	Odayeri
Flow rate	m <sup>3</sup> /day	2000-3000
pH		5.5 – 8,5
COD	mg/l	4000 - 20000
BOD <sub>5</sub>	mg/l	3000 – 13000
Temperature	°C	15-20
Total Phosphorus	mg/l	< 5
Total Kjeldahl Nitrogen (TKN)	mg/l	2000 – 5000
Suspended Solid Matter (SSM)	mg/l	300 – 1500
SO <sub>4</sub>	mg/l	500
Total Stiffness	mg CaCO <sub>3</sub> /l	1400 – 2500
Conductivity	µmhos/cm	30000 - 40000
Alkalinity	mg CaCO <sub>3</sub> /l	8000 – 13000

### 7.3.3. 1. Leachate Treatment Processes

- **Preliminary Treatment**

Collected leachate from sanitary landfill is vented with two piece of 22 Kw aerators and O<sub>2</sub> amount increased and CO<sub>2</sub> removed. Preliminary treated leachate transfers to sedimentation pool with 68 m<sup>3</sup>/h transfer pumps. Inorganic matters such as Ca and Mg react with oxygen. They leave inorganic ion phase and precipitate. It reduces hardness and suspended solid substance. Preliminary treatment sedimentation pool is shown in Figure 7.8.



Figure 7.8. Sedimentation pool (İSTAÇ, 2010)

- **Chemical Treatment**

Preliminary treated leachate sends to last sedimentation with add on some chemicals such as caustic and lime. It helps to reach intended pH level. Also lime usage helps to decrease hardness. Temperature and pH control is provided by gauges located over the

pool. Sedimentated compounds (sludge) send to sludge tank and leachate sends to ammonium evaporation.

Ammonium in leachate is evaporated by four floating aerators and two of blowers within high pH level. As a consequence 75 per cent of high toxic ammonium removed from leachate. Ammonium evaporation is shown in Figure 7.9.



Figure 7.9. Ammonium evaporation (İSTAC, 2010)

- **Heat Exchanger and Conditioning Pool**

After ammonium removal and hardness reduction gets through sand filtration to prevent congestion in pipe lines. Anaerobic bacteria in sludge live in 37 °C. Before anaerobic treatment water temperature brings to optimum and transfer happens to conditioning pool, (Figure 7.10).

In conditioning pool pH levels regulates with nutrient add in. pH drop down to 6,5-7,5 with HCl and bacteria nutrition is satisfied with FeCl<sub>3</sub> and H<sub>3</sub>PO<sub>4</sub>.



Figure 7.10. Heat Exchanger (İSTAÇ, 2010)

- **Biological Treatment**

Leachate reaches to anaerobic granule bacteria bed. Organic materials are disrupted and transformed to  $\text{CH}_4$  and  $\text{CO}_2$ . Originated methane collected at the upper most and brings to boiler house. Required heat gets from burning of methane. Excess gas burns into open flare and gives to the atmosphere. Sludge originates in reactor sends to anaerobic sludge tank. After treatment nearly 80 per cent COD (Chemical Oxygen Demand) reduction is obtained. Treated leachate is discharged to membrane system to physical treatment.

- **Physical Treatment**

Membrane system consists of two steps. First step provides sludge filtration called ultra filtration. Suspended solid matters are removed and concentrated part send back to the

bioreactor. Output water sends to the nano filtration unit. Ultra filtration unit consists of cross flow tube membranes Cross flow system provides high flow rate and prevents occlusion. System is shown in Figure 7.11.



Figure 7.11. Cross flow tube membranes (İSTAÇ, 2010)

In second step is nano filtration unit which propose to remove organic micro pollutants, heavy metals and other compounds. Nano filtration system (Figure 7.12) consists of capillary membranes. Output water with discharges standards (Table 7.4) are used for irrigation of roads, streets...etc.



Figure 7.12. Nano filtration capillary membranes (İSTAÇ, 2010)

Finally output water is ready to discharged with parameters shown in Table 7.4.

Table 7.4. Discharge standards in Odayeri, Kemberburgaz (İSTAÇ, 2010)

Parameter	Unit	Odayeri
BOD <sub>5</sub>	mg/l	-
COD	mg/l	800
SSM	mg/l	350
Total Ammonium	mg/l	
TKN	mg/l	100
Cadmium	mg/l	2
Polybutylene	mg/l	3
Copper	mg/l	5
Total Chrome	mg/l	5
Zinc	mg/l	10
pH	-	6 - 10
Temperature	°C	40
Ferrous	mg/l	-
Total P	mg/l	10

### 7.3.4. Compost Facility

In compost facility domestic waste with high organic content processed both chemical and physical reactions. Organic matters inside solid waste reacts with microorganisms in ferment areas by the help of required oxygen and dissolved. As a result nutritious, highly organic compost is produced.

In Kemberburgaz Compost Facility (Figure 7.13, 7.14) 700 tons solid waste is processed and 200 tons compost is produced. Solid waste comes to facility, separated by sieves. Organic wastes with 80mm diameter at most send to fermentation unit to produce compost.

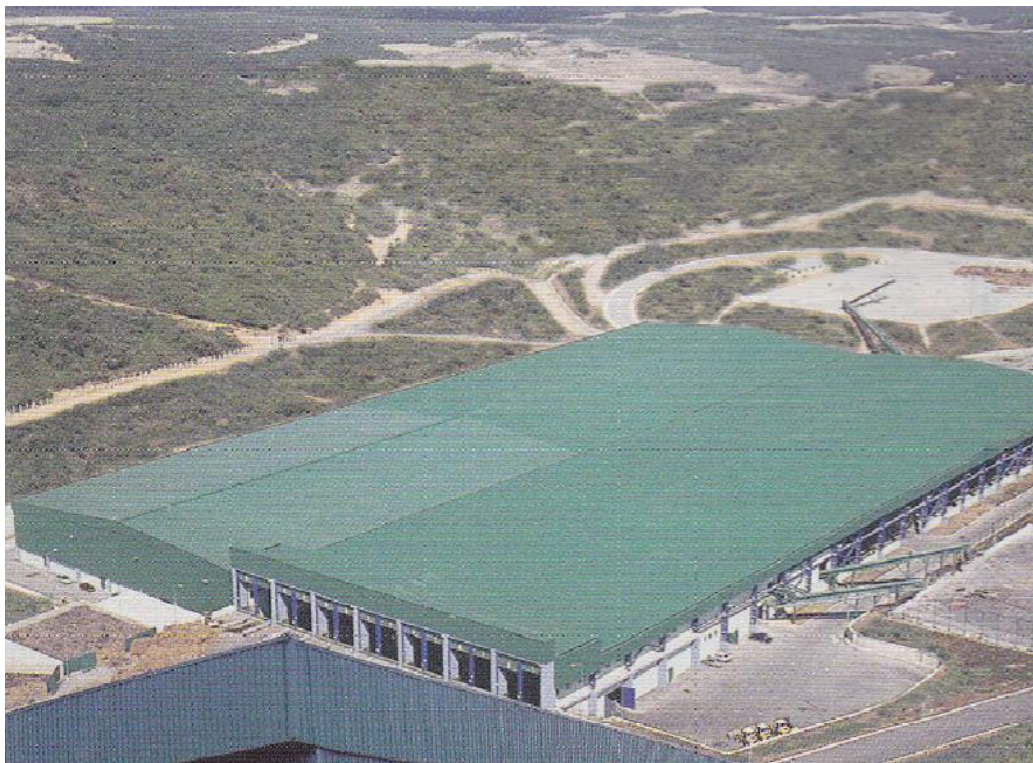

Figure 7.13. Kemberburgaz Compost Facility (İSTAÇ, 2010)

Fermentation unit consists of eight parts that three of them closed and five of is open. Solid waste is waited one week in each section which has different specific temperature

and humidity. After eight weeks, compost process ends. Product sieved finally and separated by qualification.



Figure 7.14. Kemberburgaz Compost Facility (İSTAÇ, 2010)

Wastes with 80 mm diameters and larger ones are taken to the recycling tapes and saved to the economy back. 200 tons compost is produced in facility per day. After final election half of these 200 tons exhibits to use as compost refuse product. Recycled amount is 20 tons average per day. (İSTAÇ, 2010)

Compost produced in İSTAÇ AŞ. has less heavy metal values than US, Canada, Greece, Spain, New Zealand and Italy limits (Table 7.5).

Table 7.5. Heavy Metal Values (mg/kg dry compost) (İSTAÇ, 2010)

Heavy Metal	EU Org. Compost (2092/91EC-1488/98EC)	EU-eco Compost (2001/688/EC)	Average values of EU members	EU average (mixed)	İSTAÇ
Cd	0.7	1	1,4	1,7-5,0	1,4
Cr	70	100	93	70-209	131
Cu	70	100	143	114-522	352
Hg	0,4	1	1	1,3-2,4	1,1
Ni	25	50	47	30-149	74
Pb	45	100	121	181-720	137
Zn	200	300	416	283-1570	594

Compost (Figure 7.15.) provides lots of advantages to soil. It increases space volume, provides soil to ventilate and easy farm and increase organic amount. Compost is utilized to improve ground floor in gardens, sport areas and parks like fertilizer. Municipality uses the compost in landscape projects of Istanbul.



Figure 7.15. Compost produced in Kemberburgaz Compost Facility (İSTAÇ, 2010)

### 7.3.5. General Properties of Energy Recovery Plant

Ortadogu Enerji A.S. of Istanbul, Turkey has undertaken the Istanbul landfill gas to energy project after winning the tender held by the Istanbul municipality company ISTAC A.S. The energy plant, which has started the conversion of energy to Electricity in December 2008, has a current realized capacity of about 15 MW, and supplies about 60,000 homes. However it is considered reaching its peak value at the end of 2010 and hence installed capacity is 25 MW.

Technical features of the project are summarized below:

- Project start date: March 2007
- Operational life: 23 years
- Start of energy conversion: December 2008
- Total peak power estimated: 25 MW (depending on the gas production outcome of the landfill site)
- Ratio of the 23 year average to the peak value of 2010: About 75%
- Total estimated carbon credits: About 0,72 million ton/year CO<sub>2</sub> eq. for the first 7 years
- Total number of gas collection wells: 133 wells
- Total length of gas, leachate, and compressed air pipes: 50 km
- Blower system capacity: Suction -120 mbar, Pressure +130 mbar, 17,500Nm<sup>3</sup>/hr
- Flare capacity: 5,000 Nm<sup>3</sup>/hr
- Gen-Sets: Each with 1.4 MW power, a total of 10-20 units depending on the gas production outcome of the landfill site
- Placement of gen-sets: Enclosed in a pre-fabricated concrete power house with 20 gen-set capacity
- Length of electricity transportation lines: 20 km
- Total investment cost: Approximately 20 million Euros (Gülüt, 2009).

### 7.3.6. Main Elements of Landfill Gas to Energy Plant

Istanbul-Kemberburgaz Landfill gas to energy power plant consists of three main elements described below:

1. Gas Collection System
  - a. Gas Collection wells
  - b. Leachate disposal system
  - c. Gas pipe lines
  - d. Well vacuum optimization system
  - e. Precipitation water disposal system
  - f. Manifolds
  - g. Leachate pipe lines
  - h. Pressurized air pipe lines
  
2. Gas Conditioning System
  - a. Absorption and Pressurizing
  - b. Moisture purification
  - c. Filtration
  - d. Flare (excess gas)
  
3. Electricity Generation and Distribution System
  - a. Gen-Sets
    - i. Gas engines
    - ii. Generators
    - iii. Engine-control
    - iv. Engine commutator
  - b. Amplifier
  - c. Middle voltage contactor
  - d. Power meter
  - e. Middle voltage distribution line

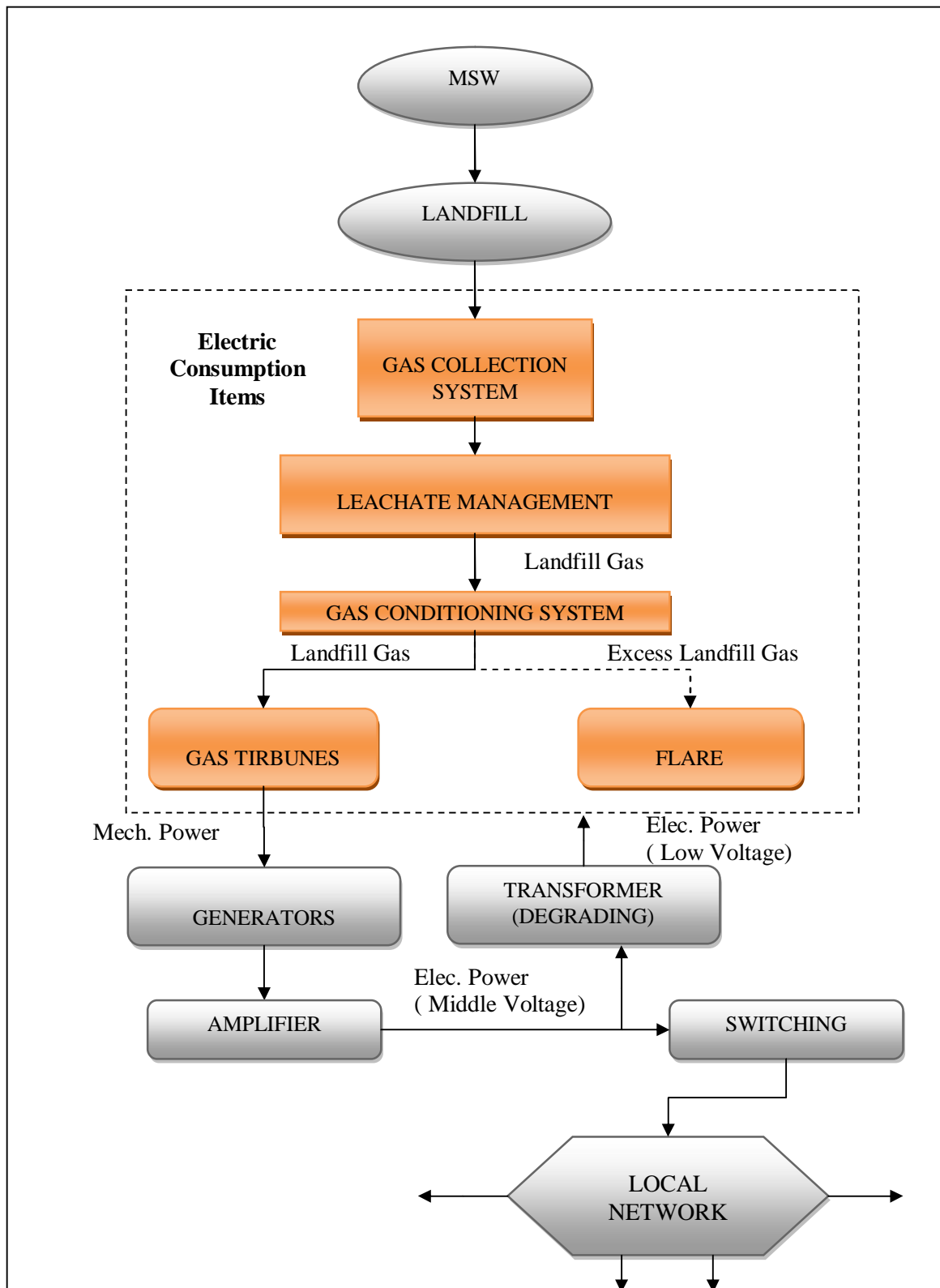

Figure 7.16. Schema of Landfill Gas to Energy Power Plant (Gülüt, 2009)

7.3.6.1. Gas Collection System.. Project consists of three design steps (see Figure 7.16). According to the design roadmap first stage is established until now. 133 piece of collection wells with depth of 15-45 meters drilled. These drilled wells considered to collect gas from 50 meters diameter length area. Gas is collected with an average of -30mbar with PN 16 pipes. They have connected to 12 collection manifolds. Leachate on the field absorbs by pumps located in the vertical leachate wells around the field. Collected leachate transfers to the leachate treatment center by HDPE pipes. Genplan of gas collection wells is shown in Figure 7.17.

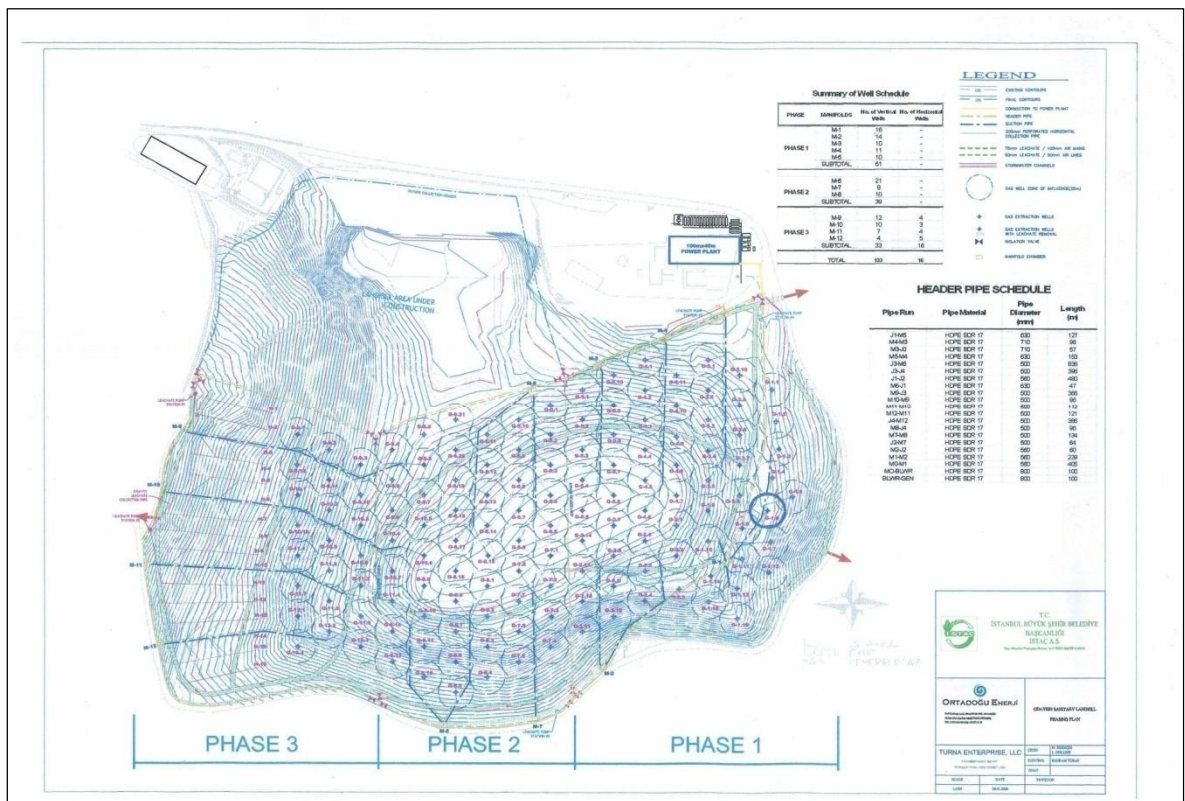

Figure 7.17. Genplan of Gas Collection Wells of Kemberburgaz Sanitary Landfill with Effective Diameters (Kiriş and Saltabaş, 2009)

7.3.6.2. Gas Conditioning System. Gas absorbs with blowers from field as mentioned above. It transfers to the gas treatment and chilling compartment with main pipes. In this compartment gas is purified from the particles and moisture inside. If gas temperature raises up to 45 Celsius centigrade chillers engages to decrease temperature to suitable condition for gas engines. In case of any problem or excessive gas input, three flares burn excess gas with 2000m<sup>3</sup>/hr capacity. Typical conditioning system is shown in Figure 7.18. (Kiriş and Saltabaş, 2009).

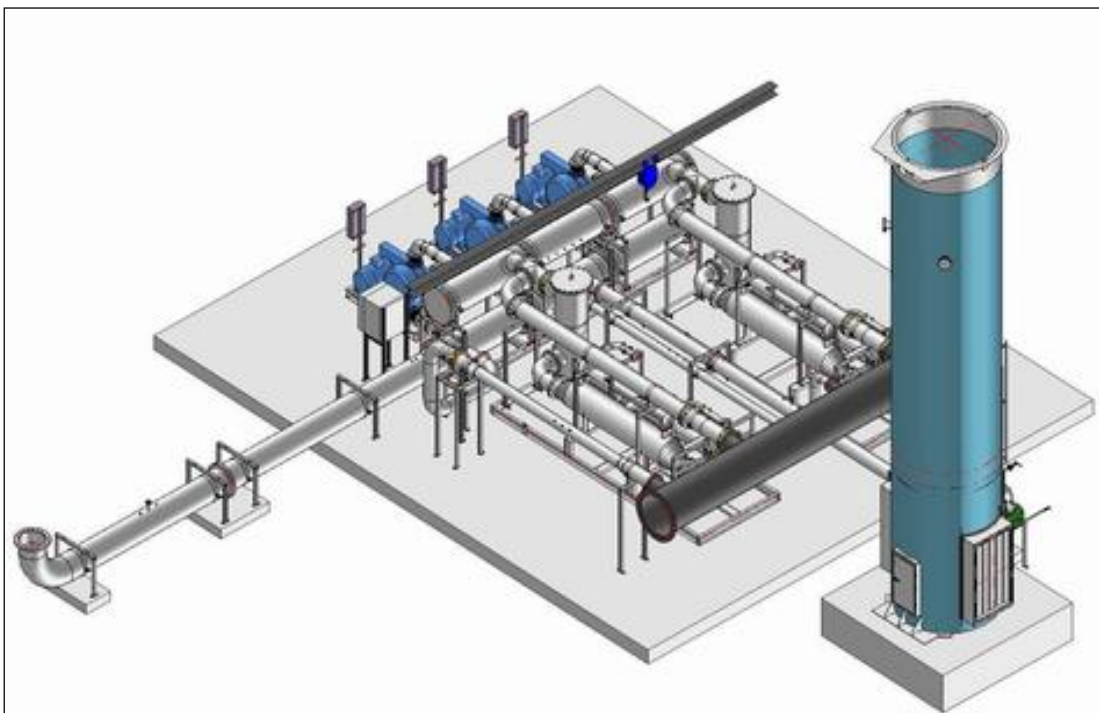

Figure 7.18. Typical conditioning system with flare (Kiriş and Saltabaş, 2009)

7.3.6.3. Electricity Generation and Distribution System. Each with 1.44 MW power, total of 11 units gen-set are used in the power plant. At the present 7-8 of them operate depending on the gas production outcome of the landfill. However power plant is designed to operate 20 units gen-set to generate up to 25 MW power. Calculations and considerations shows that peak value shall be reached at the end of 2010. These 20 cylinder engines operate with 4-stroke engine principle and 400 volts of electric power discharges. It escalates to 34.5 KV middle voltages in order to supply interconnected electricity lines. Electricity Gen-set with gas engine is shown in Figure 7.19.

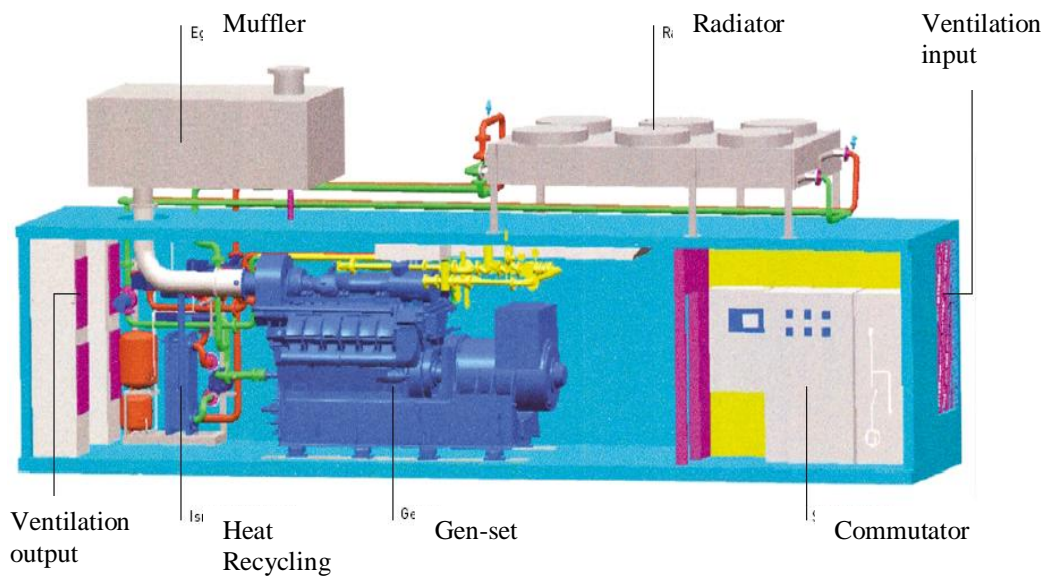

Figure 7.19. Typical Electricity Generation System with Gas Engine (Aksoy, 2009)

Methane concentration is extremely important for engines and must be controlled. If methane concentration decreases, velocity of gas blower and therefore gas engine output must be reduced. Energy balance of Gen-set with gas engine is shown in Figure 7.20.

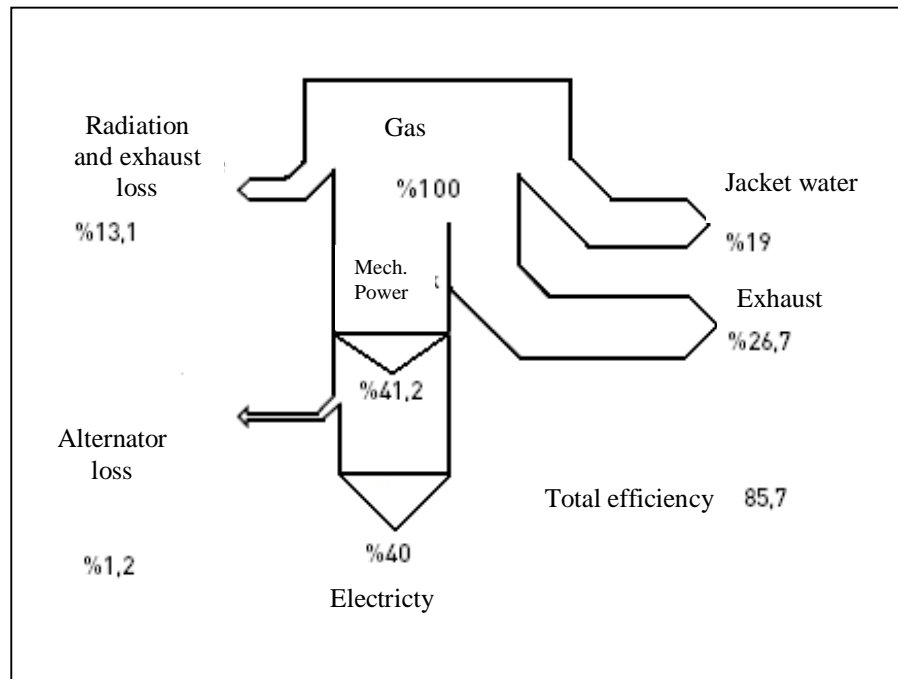

Figure 7.20. Energy balance of Gen-set with gas engine (Aksoy, 2009)

## 7.4 Economic Valuation of The Project

### 7.4.1. Gas and Electricity Profile

The temperature of obtained LFG is significant that more than 45 °C requires chilling. Average temperature values show seasonal changes. In summer season it generally exceeds the limit of 45 °C and go into chillers in daily time. Average temperature values of LFG depending on months are shown in Figure 7.21.

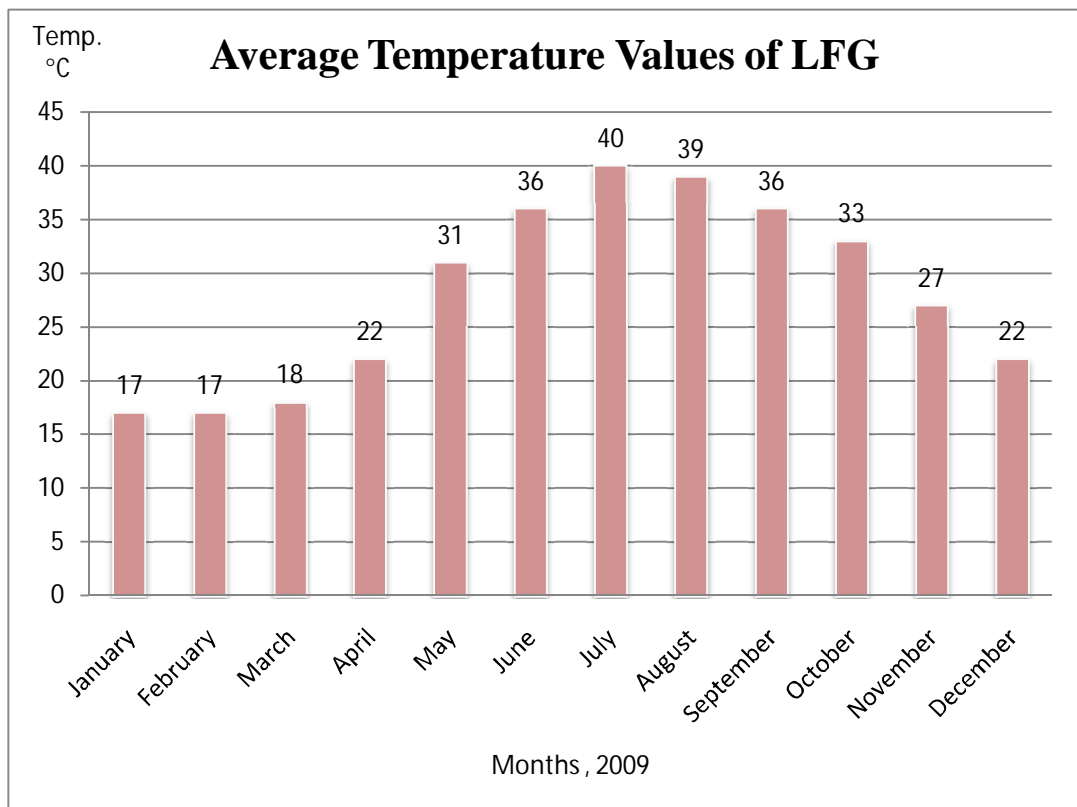

Figure 7.21. Average temperature values of LFG in Kemberburgaz (İSTAÇ, 2010)

Obtaining LFG without vacuum pressure almost is not possible if you want to generate electricity especially. Therefore gas collection wells and manifolds which

connected to nearly eleven of them have to operate with a negative vacuum pressure. Average absorption pressure values throughout 2009, are shown in Figure 8.2.

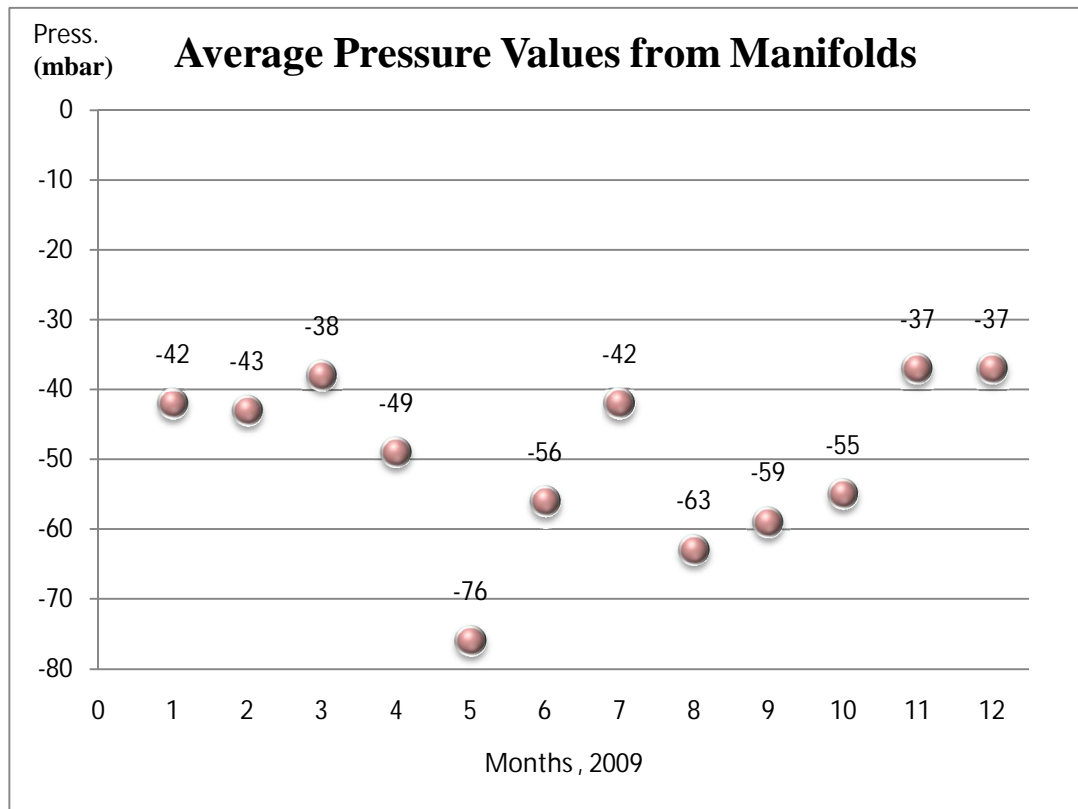

Figure 7.22. Average absorption pressure values through 2009 (İSTAÇ, 2010)

Wells are being located side by side with 50 meters diameter blanks. Experiments show that effective radius of gas collection wells is 25 meters. Due to the fact that wells have begun the drilled just 1.5 year ago collected gas data is not as consistent as it must throughout 2009. Obtaining the same amount of LFG from all over the field is not possible that engineers opening new small wells where results show older ones are not adequate. Figure 7.23 shows the amount of methane obtaining from field per hour throughout 2009.

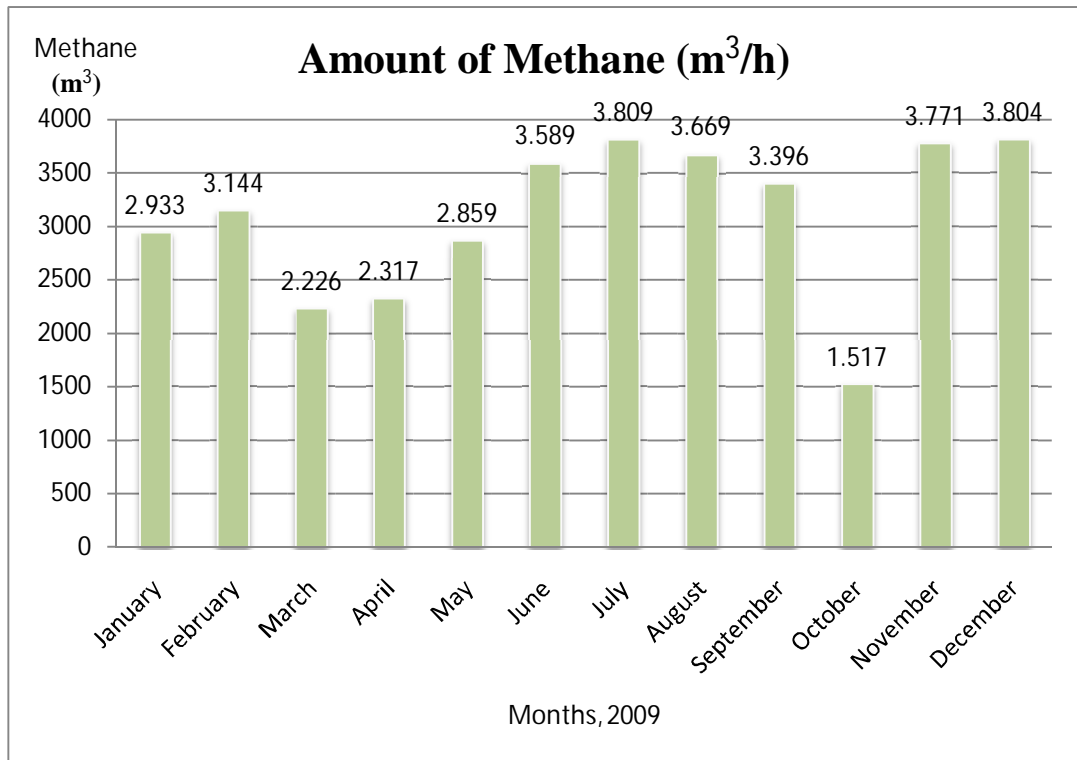

Figure 7.23. The amount of methane obtaining from field per hour (İSTAÇ, 2010)

There are 11 gen-sets in the Kemerburgaz gas to energy plant. Each one is 1,44 MW installed capacity. Electricity has begun to generate on December 2008. Facility has been designed for 20 gen-set in an enclosed prefabricated concrete power house. According to the experiment results and numerical approximations project will reach ultimate capacity at the end of 2010. Although five of eleven gen-sets operate at the beginning of the year, 2009, just after first quarter two more gen-sets have added to operation. Figure 7.24 show the generated electricity from these installed internal combustion gen-sets.

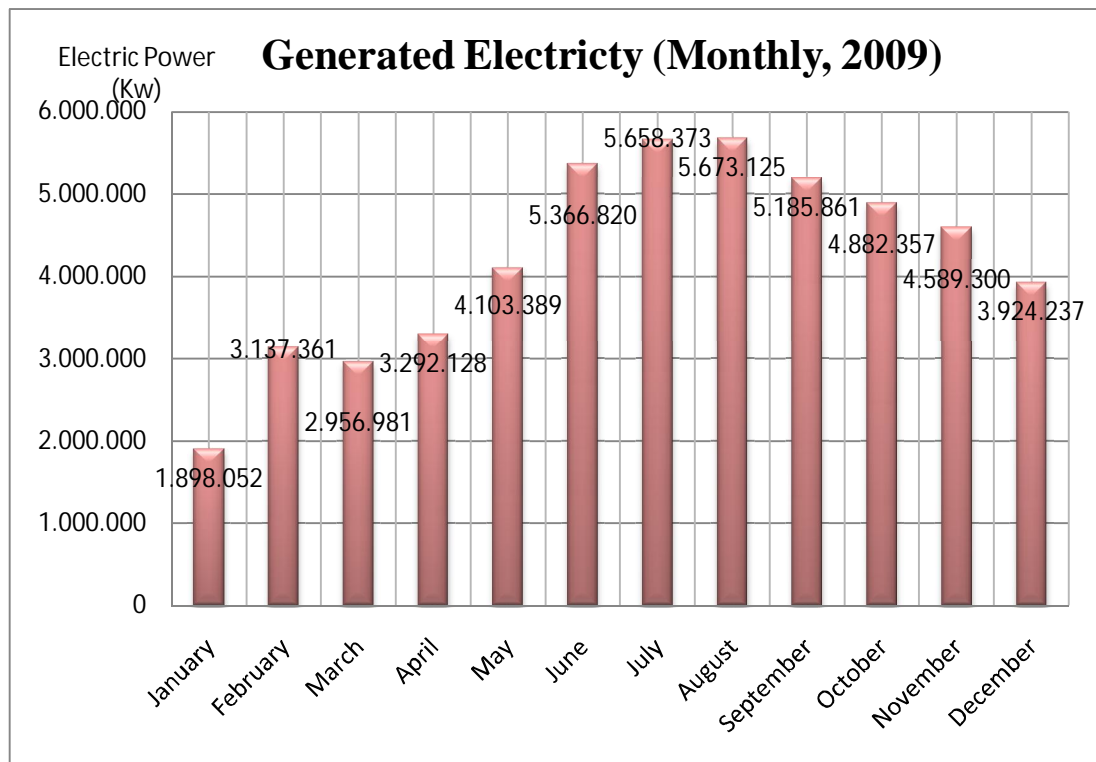

Figure 7.24. Generated Electricity in Kemerburgaz Gas to Energy Facility (İSTAÇ, 2010)

Throughout the project design, high energy efficiency and minimum life cost have been the top priority, resulting in about 11.5 per cent more energy being delivered to the national electric grid as compared to typical project implementations. Facility has already provided 10 MW power and approximately 30,000 houses have benefited. When second and third phase of project have been completed, it is considered to obtain 20 to 25 MW electric power. Figure 7.25 shows generated total electricity amount by the end of year, 2009.

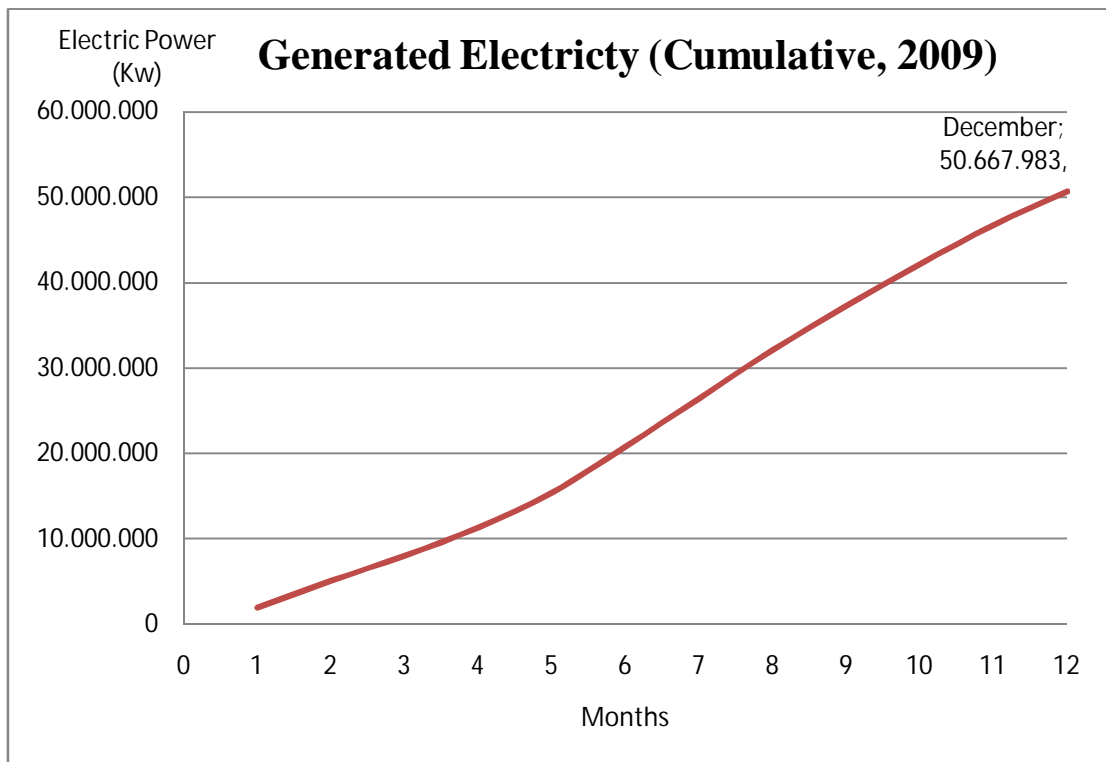

Figure 7.25. Total Generated Electricity through 2009 in Kemberburgaz Gas to Energy Facility (İSTAÇ, 2010)

#### 7.4.2. Investment

The investments have accelerated as a result of "Renewable Energy Law" which has passed into law in May 2005, and purchase price guarantees from Government. 13.614 MW installed capacity that has performed at the last quarter of 2008, considered to reach 23.500 MW in 2012 with nearly 10 billion Euros investment as shown in Figure 7.26, (Gülsoy, 2009).

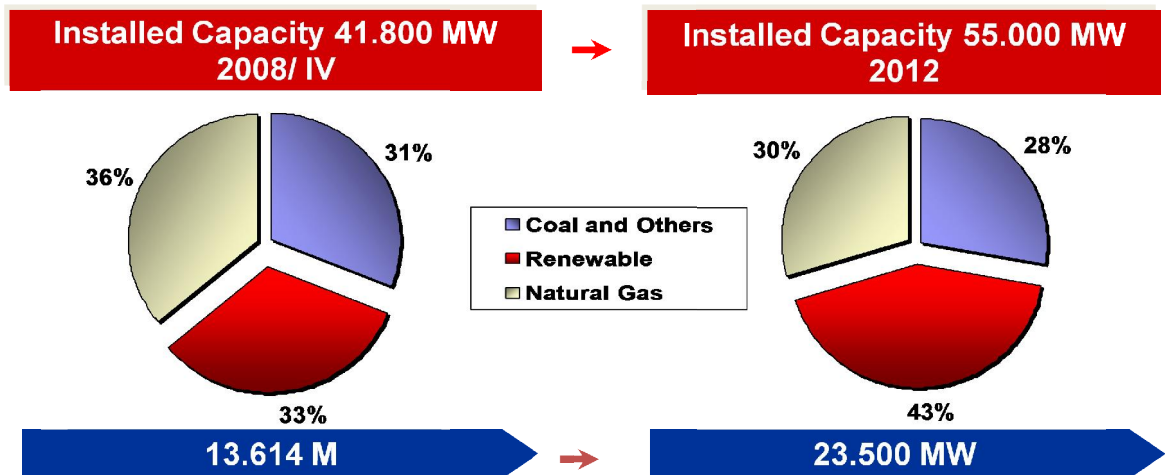

Figure 7.26. The Prospect of Renewable Energy in Turkey (Gülsoy, 2009)

Funding of waste to energy projects is similar to renewable energy projects. Debit return, repayment period, internal efficiency performance and net present value of project are calculated by the help of investment and operating period data. Turkish Development Bank (TKB) and Turkish Industry and Development Bank (TSKB) are the main fund suppliers of waste to energy investment projects.

These Government and Treasury supported banks obtain credits from various corporations such as; World Bank, European Development Bank, Islamic Development Bank, International Finance Corporation.

Biogas facilities are generally being constructed into two years. These government and treasury supported banks or private finance corporations provide two years non-refundable plus seven years refundable credits. It is able to reach up to four years for non-refundable and fourteen years for refundable parts. Project investment part from Finance Corporation can be 80 per cent depending on the project efficiency performance and net present value.

### 7.4.3. Carbon Market

Waste to energy projects are the main actors of carbon market. Turkey is now inside the Voluntary Carbon Market. Different kinds of standards and certificates have been progressed such as VCS (Voluntary Carbon Standard), Gold (Gold Standard), CAR (Climate Action Reserve) and ACR (American Carbon Registry). Although VCS is the most common standard being used in the world, Gold standard (VER) is being preferred in premier in Turkey. Main reason is Gold Standard's high price in the Carbon Market. In Figures 7.27 and Figure 7.28 usage of these certifies in the world and Turkey are shown respectively.

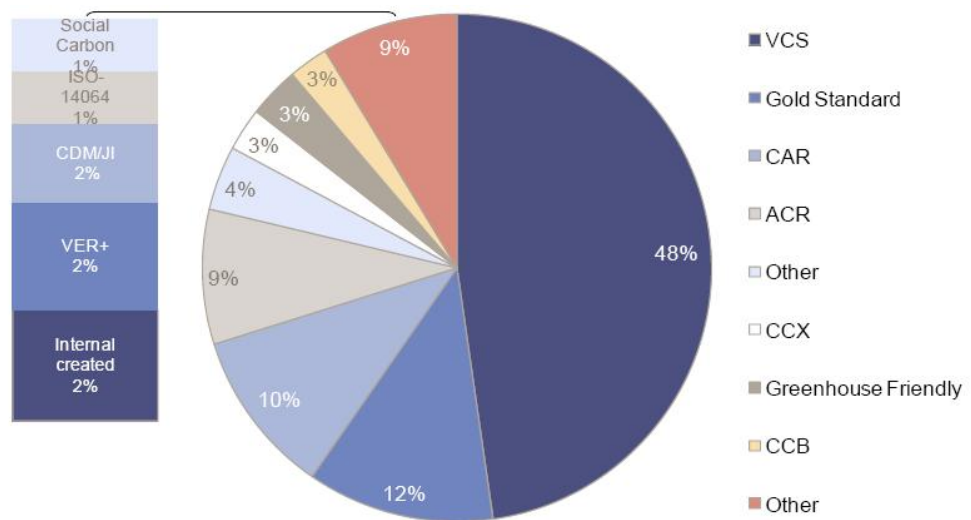

Figures 7.27. Carbon certifies distribution in the world (Eren, 2009)

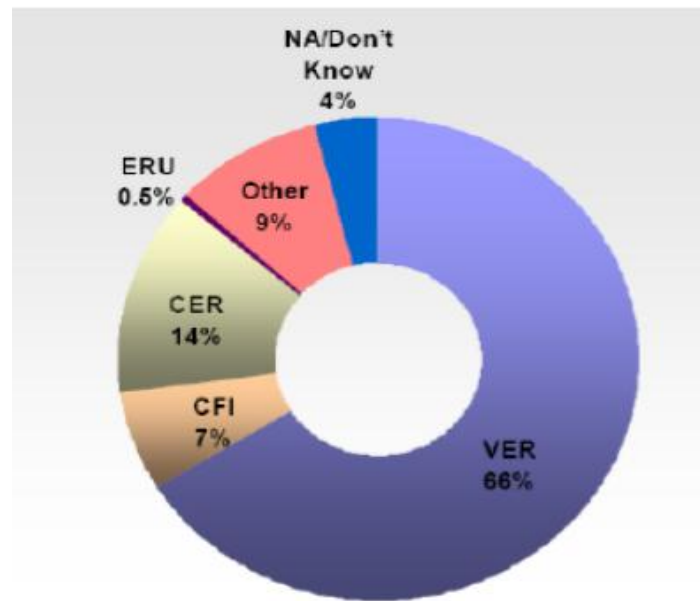

Figure 7.28. Carbon certifies distribution in Turkey (Öztürk, 2009)

The variation of carbon purchase prices in Voluntary Carbon Market into last two years is shown in Figure 7.29.

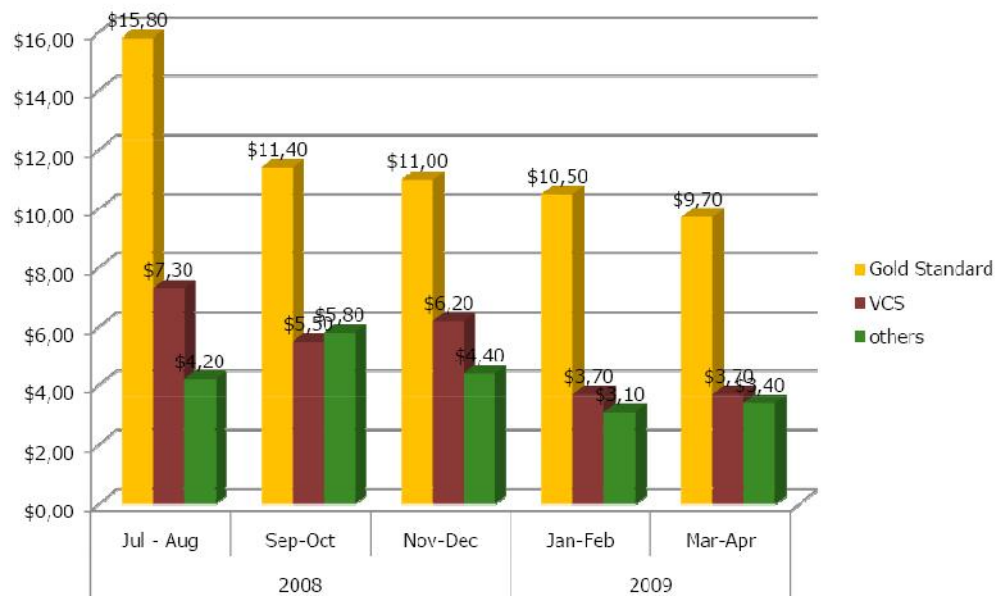

Figure 7.29. The variation of carbon purchase prices in Voluntary Carbon Market (Eren, 2009)

In 2010 decrease of price continues and comes to 8,00 USD/ton. It is considered to gain one million tons CO<sub>2</sub> per year in the first seven years as carbon credits (Gülüt, 2009).

#### **7.4.4. Carbon Emission Potential**

Bioelectricity projects provide carbon emission beside electricity generation. Established systems burns methane which is 21 times much more hazardous than CO<sub>2</sub> in the case of global warming. Due to this emission reduction done via electricity generation, such projects are supported by Gold Standard that is the most prestigious one in the world.

Average of 11 millions of tons of carbon emission reduction is expected through the project lifetime which is nearly 22 years. It is the total amount of both Kemberburgaz and Kömürçüoda facilities. This amount is equal to carbon emission of approximately 600,000 cars in traffic.

#### **7.4.5. Revenue**

In the guide of all of this information an approximate analysis of the project has been performed. It was considered that seven of eleven gen-sets is working 8000 hrs/year and each one operates 1,44MW electric power with 41,60 per cent electric, 98,90 per cent substations and 96,04 per cent energy transportation line efficiencies (Gülüt, 2009).

Approximately a hundred people work. Gen- sets are subjected to periodic maintenance in place by twice a year. Responsibility belongs to distributor of Gen-sets in Turkey. Also one technician from company works in facility permanently.

Electric purchase guarantee price has been taken 0,10 USD as an average of last two years (EPDK, 2010). Carbon contract revenue has not gained yet. However negotiations continue that considered to make an agreement at the end of 2010. Economic return of the project (2009) with these approximations is shown in Table 7.6 and 7.7 respectively.

Table 7.6. Total Annual Income<sup>6</sup>

Total Electrical Energy Income	5.064.000 USD/year
Carbon Contract Income	390.000 USD/year
<b>Total Annual Income</b>	<b>5.454.000 USD/year</b>

Table 7.7. Total Annual Expenditure<sup>7</sup>

Personal Expenses	100.000 USD/year
Consulting	50.000 USD/year
Insurance	150.000 USD/year
Operation and Maintenance	1.050.000 USD/year
Treatment Plant	2.250.000 USD/year
TEİAŞ System Price	55.000 USD/year
Miscellaneous	50.000 USD/year
<b>Total Annual Expenditure</b>	<b>3.705.000 USD/year</b>

<sup>6</sup> Carbon contracts are in negotiation stage. Values are intended and approximate.

<sup>7</sup> Financial credit repayments are not taken into account. Values are approximate and obtained from İSTAÇ Kemerburgaz Supervision Department via interview.

## 8. CASE STUDY: METROPOLIS BURSA

### 8.1. General Information about Bursa

Bursa is a city in northwestern Turkey and the seat of Bursa Province with a population of 2,550,645 (Turkish Statistical Institute, 2009). It is Turkey's fourth largest city, as well as one of the most industrialized and culturally charged metropolitan centers in the country. Bursa is settled on the northwestern slopes of Mount Uludağ in the southern Marmara Region. It is bordered by the Sea of Marmara and Yalova to the north; Kocaeli and Sakarya to northeast; Bilecik to the east; and Kütahya and Balıkesir to the south.

The weather of district shows characteristics of Marmara climatic region. While, the hottest month of the year is July, the coldest month is February. The rainy weather can be seen mostly in winter and spring time. The annual average precipitation is about 500-700 mm. The humidity in district is about 58% in average. Figure 8.1. shows the average low and high temperature values of Bursa (EPCA, 2010).

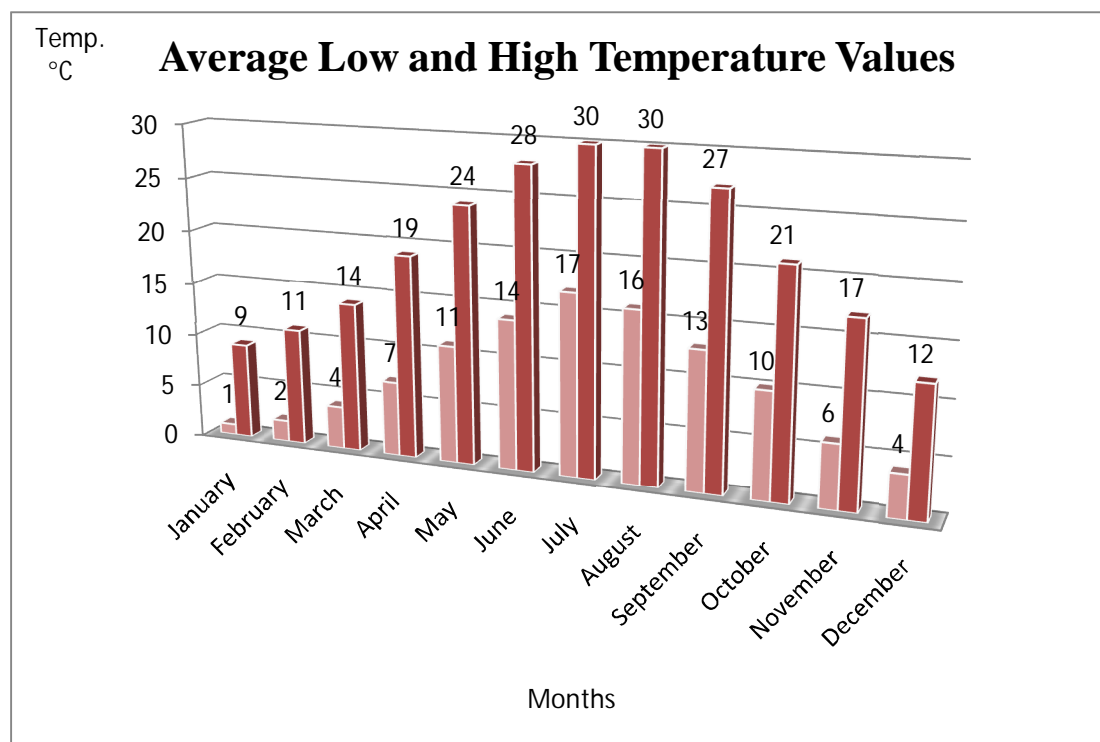

Figure 8.1. The average low and high temperature values of Bursa (EPCA, 2010)

## 8.2. Integrated Waste Management in Bursa

Approximately 1,810 tons/day municipal solid waste is collecting from Osmangazi, Yıldırım, Nilüfer, Mudanya, Gürsu, Kestel and Zeytinbağı municipalities and transfer to the Sanitary Landfill in Geçit region. 83,09 hectares is being used for municipal solid waste filling of total of 156,18 hectares. 40 hectares of this area is completed for sanitary landfilling and rest of 43 hectares is continuing to construct. Sanitary waste landfilling is completed within first area. Second and third step is continuing from November, 2000.

- **Hazardous waste analyze and report of Industrial Solid Wastes comes to Municipal Sanitary Landfill.**

There is a full equipped laboratory which is relative to administration department in Municipal Sanitary Landfill. In laboratory, leachate, underground water and solid waste are analyzed, controlled and evaluated.

- **Medical wastes are collected with medical waste trucks and bring to the sterilization facilities within Control Regulations of Medical Wastes.**

Bursa Medical Waste Sterilization Facility (Figure 8.2.) has begun to operate July, 2008 connected to Municipality of Metropolis Bursa. This facility is the first sample facility in Turkey, constructed in a 2000 meter square area. Otaklava Sterilization technique is used. Wastes are being sterilized under high temperature and pressurized tanks with monitoring. 2,486.77 tons of medical waste disposed in 2009. Figure 8.2. shows the sterilization tanks.



Figure 8.2. Bursa Medical Waste Sterilization Facility (EPCA, 2010)



Figure 8.3. Sterilization tanks (EPCA, 2010)

### **8.3. Bursa Municipal Sanitary Landfill**

Today, population growth, technological development and urbanization, both in terms of rapidly growing solid waste amount and contents to the nature of adverse effects has become an important environmental problem. Waste resulting leachate cause to pollute underground water, the gases result of the organic content of waste dissolution cause air pollution and explosion risk and aesthetically bad images. Preventing of all these outcomes, landfills are formed.

The system is applied to landfill for the disposal of household waste arising from residential areas, industrial processes arising from non-hazardous waste and medical waste arising from health care facilities, since 1995. The first study in this direction initially started in 1989. In 1992, "the preparation of municipal and industrial solid waste management study", has been requested from the World Bank loan. 12.5 million of identified 23 million dollars acquired from World Bank. Loan agreement was signed, approved in 1993, and commissioned.

New garbage storage area as an alternative to the three places designated in the feasibility study, the most suitable alternative location is selected as the neighborhood of Geçit. Projected area of study selected in accordance with 156.18 hectares and 83.09 hectares of this area is the garbage dump area. Total capacity is 20 million m<sup>3</sup> and will be used until the year 2025. The project area consists of the four side valleys (X, Y, Z, T) and a main valley, and the stage of construction is done in accordance with the requirement. 43.05 hectares; forms part I. Stage (X and T of the whole valley), II. Stage (the main part of the valley), and III. Stage (a section of the main valleys) construction has been completed. The remaining 40.04 hectares section has not been realized yet. Valleys can be seen in Figure 8.4.



Figure 8.4. Municipal Sanitary Landfill in Geçit, Bursa (EPCA, 2010)

### 8.3.1. Design Properties of Geçit Sanitary Landfill

Landfills in the area, the most important problem of environmental pollution constitute the leachate. Any contaminants contained in the content parameter of the leachate, groundwater and surface water sources are polluted. To avoid these negative effects of the leachate, basement of the storage area is made impermeable. (See Figure 8.5).

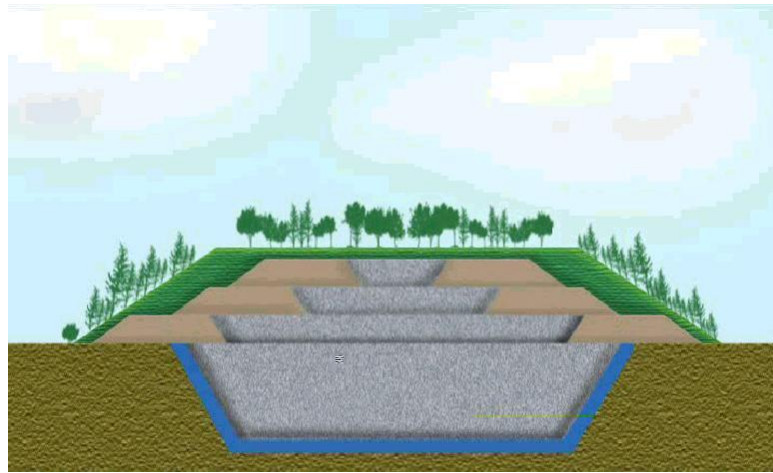

Figure 8.5. Landfill valleys cross section in Geçit, Bursa (EPCA, 2010)

Table 8.1. Properties of Valley X (EPCA, 2010)

Total Area	: 3.7 ha
Solid waste landfilled	: 204,517 ton
Landfilled time	: August, 1995-October, 1996 (15 months)
Landfilled volume	: 300.000 m <sup>3</sup>
Start of work	: August, 1993
Finish of work	: December, 1994
Valley cost	: 1,132,500 \$
Total cost	: 1,540,000 \$
Cost per unit area	: 30.61 \$/ m <sup>2</sup>
Cost per unit volume	: 3.78 \$/ m <sup>3</sup>

Table 8.2. Drainage cross section of Valley X (EPCA, 2010).

WASTE COVER + TOP SOIL
WASTE
DRAINAGE AGGREGATE (30 cm, 16/32)
SAND (5 cm)
GEOMEMBRANE (2 mm)
CLAY (60 cm)
UNDERGROUND DRAINAGE LAYER (30 cm)
GROUND SOIL

**Valley T;**

Figure 8.6. First step Valley T (EPCA, 2010)

Table 8.3. Properties of Valley T (EPCA, 2010)

Total Area	: 8.8 ha
Solid waste landfilled	: 1,369,175 tons
Landfilled time	: November, 1996 - October, 1996 (4 years)
Landfilled volume	: 1,000,000 m <sup>3</sup>
Start of work	: May, 1995
Finish of work	: December, 1996
Total cost	: 1,370,000 \$
Cost per unit area	: 15.57 \$/ m <sup>2</sup>
Cost per unit volume	: 1.37 \$/ m <sup>3</sup>

Table 8.4. Drainage cross section of Valley T (EPCA, 2010)

WASTE COVER + TOP SOIL
WASTE
DRAINAGE AGGREGATE (30 cm, 16/32)
CLAY (120 cm)
UNDERGROUND DRAINAGE LAYER (30 cm)
GROUND SOIL

### Second Stage (MainValley) ;



Figure 8.7. Second Stage (MainValley) (EPCA, 2010)

Table 8.5. Properties of Second Stage - Main Valley (EPCA, 2010)

Total Area	: 18 ha
Landfilled volume	: 1,100,000 m <sup>3</sup>
Start of work	: April, 1998
Finish of work	: November, 1999
Total cost	: 1,600,000 \$
Cost per unit area	: 8.89 \$/ m <sup>2</sup>
Cost per unit volume	: 1.45 \$/ m <sup>3</sup>

Table 8.6. Drainage cross section of MainValley (EPCA, 2010)

WASTE COVER + TOP SOIL
WASTE
DRAINAGE AGGREGATE (30 cm, 16/32)
CLAY (120 cm)
UNDERGROUND DRAINAGE LAYER (30 cm)
GROUND SOIL

**Third Stage (MainValley) ;**

Figure 8.8. Third Stage (MainValley) (EPCA, 2010)

Table 8.7. Properties of Third Stage - Main Valley (EPCA, 2010)

Total Area	: 12.55 ha
Landfilled volume	: 2,000,000 m <sup>3</sup>
Start of work	: March, 2004
Finish of work	: October, 2004
Total cost	: 1,449,077 \$
Cost per unit area	: 11.59 \$/ m <sup>2</sup>
Cost per unit volume	: 0.72 \$/ m <sup>3</sup>

Table 8.8. Drainage cross section of MainValley (EPCA, 2010)

WASTE COVER + TOP SOIL
WASTE
DRAINAGE AGGREGATE (30 cm, 16/32)
CLAY (60 cm)
UNDERGROUND DRAINAGE LAYER (30 cm)
GROUND SOIL

A summary of all valley capacities can be seen in Table 8.9.

Table 8.9. Disposed solid waste amounts in Sanitary Landfill since 1995 (EPCA, 2010)

STAGE	VALLEY	STORAGE TIME		VALLEY CAPACITY (Ha.)	TOTAL (Tons)
I.	X VALLEY	August, 1995- October, 1996	15 months	3.7	204,517
	T VALLEY	November, 1996 – October, 2000	4 years	8.8	1,369,175
II.	MAIN VALLEY	October, 2000 – Cont.	9 years, 3 months	18	5,165,792
III.	MAIN VALLEY			12.55	
GRAND TOTAL		August, 1995-...	14,5 Years	43.05	6,739,484
EXPECTED		1995-2025	30 Years	83.09	22,200,000

### 8.3.2. Contents of Geçit Solid Waste

Organic content of waste is extremely important for obtaining methane gas to generate electric. Due to the consumption amounts and grade, it is related to income level of communities. Table 8.10. shows the components of solid waste according to three different income levels in Bursa.

Table 8.10. The components of solid waste according to three different income levels in Bursa. (EPCA, 2010)

<b>Solid Waste Characterization</b>						
<b>Solid Waste Components</b>	<b>Income Levels</b>					
	<b>Low Inc.</b>		<b>High Inc.</b>		<b>Middle</b>	
	<b>Net Weight (kg)</b>	<b>Percentage (%)</b>	<b>Net Weight (kg)</b>	<b>Percentage (%)</b>	<b>Net Weight (kg)</b>	<b>Percentage (%)</b>
<b>Kitchen Wastes</b>	365,92	63,54%	22,66	9,26%	13,91	9,50%
<b>Paper</b>	6,42	1,11%	4,66	1,90%	45,55	31,10%
<b>Cardboard</b>	2,91	0,51%	0,50	0,20%	0,73	0,50%
<b>Volumetric Cardboard</b>	8,52	1,48%	7,64	3,12%	16,88	11,52%
<b>Plastic</b>	81,08	14,08%	22,00	8,99%	31,44	21,47%
<b>Glass</b>	7,16	1,24%	1,15	0,47%	6,50	4,44%
<b>Metal</b>	2,86	0,50%	0,77	0,31%	0,53	0,36%
<b>Landscaping wastes</b>	10,79	1,87%	154,00	62,93%	1,50	1,02%
<b>Other nonflammables</b>	23,87	4,14%	0,00	0,00%	10,95	7,48%
<b>Other flammables</b>	66,35	11,52%	31,33	12,80%	18,48	12,62%
<b>TOTAL</b>	575,88	100,00%	244,70	100,00%	146,47	100,00%

#### 8.4. Solid Waste Capacity of Geçit Sanitary Landfill

Approximately 1810 tons/day of solid waste, consisting of both residential and industrial areas from Osmangazi, Yıldırım, Nilüfer, Mudanya Gürsu, Kestel and Zeytinbağı, is collected and brought to Geçit sanitary landfill (Figure 8.9).



Figure 8.9. Geçit Sanitary Landfill (EPCA, 2010)

The process of waste disposal in the valley was completed in phase I. Second and third stages continue in the main valley since October 2000. Total of 6,739,483 tons waste is stored by the end of 2009. The total capacity of 20 million m<sup>3</sup> of storage space, and will be used until the year 2025. Collected amount of waste can be seen in Figure 8.10 and 11 annual and cumulatively since 1995.

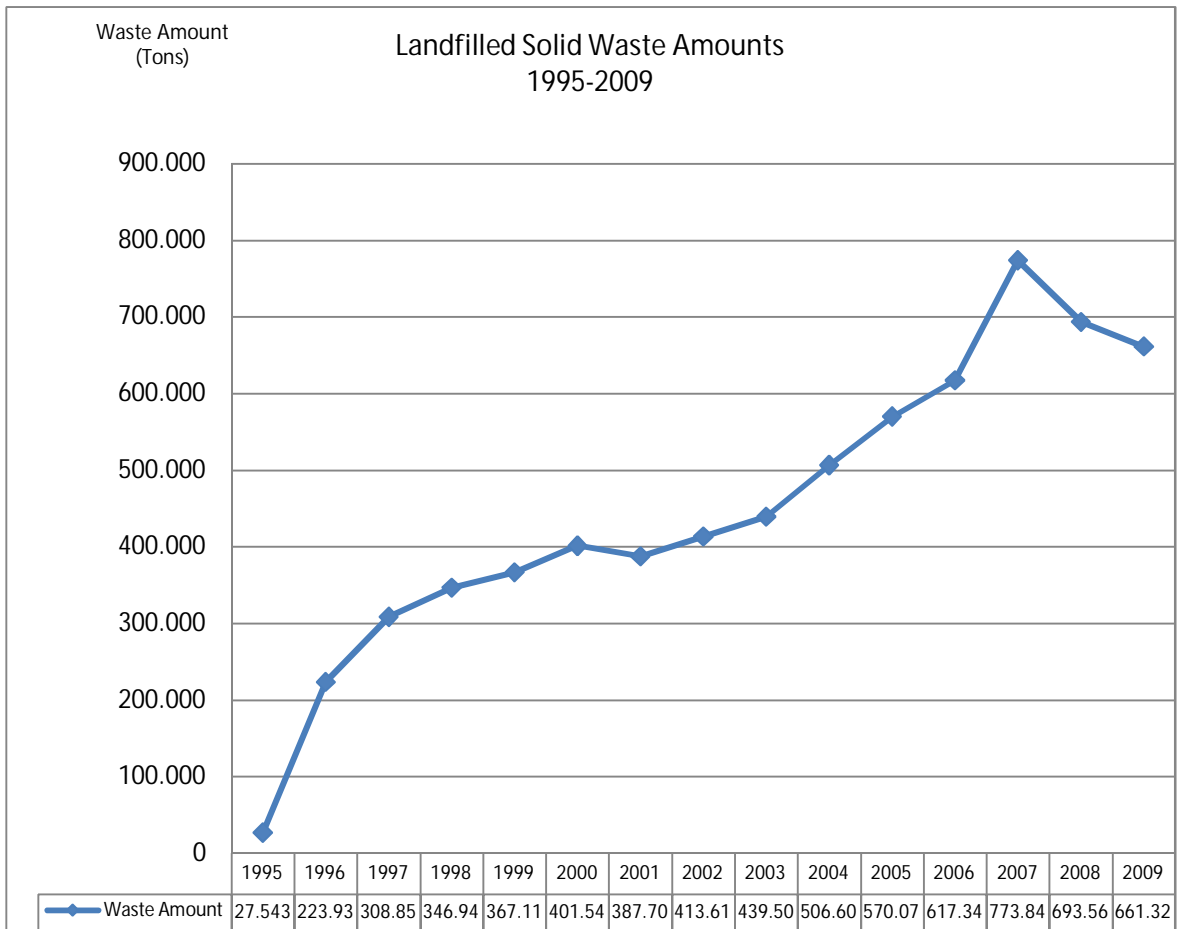

Figure 8.10. Annual collected amount of waste since 1995 (EPCA, 2010)

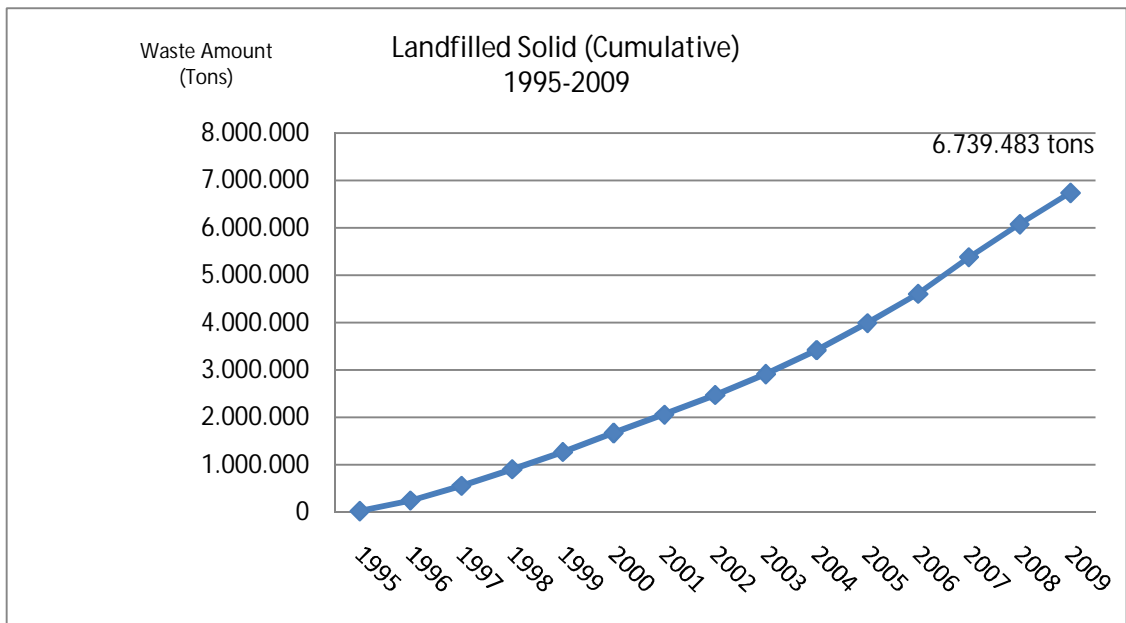

Figure 8.11. Cumulative collected amount of waste since 1995 (EPCA, 2010)

Both developing technology and collection techniques contribute to dispose more waste day by day. It shows an increasing plot since 1995. Especially collected amount rises due to attend new territory municipalities inside Bursa boundaries. Monthly averages can be seen in Figure 8.12. since 1995.

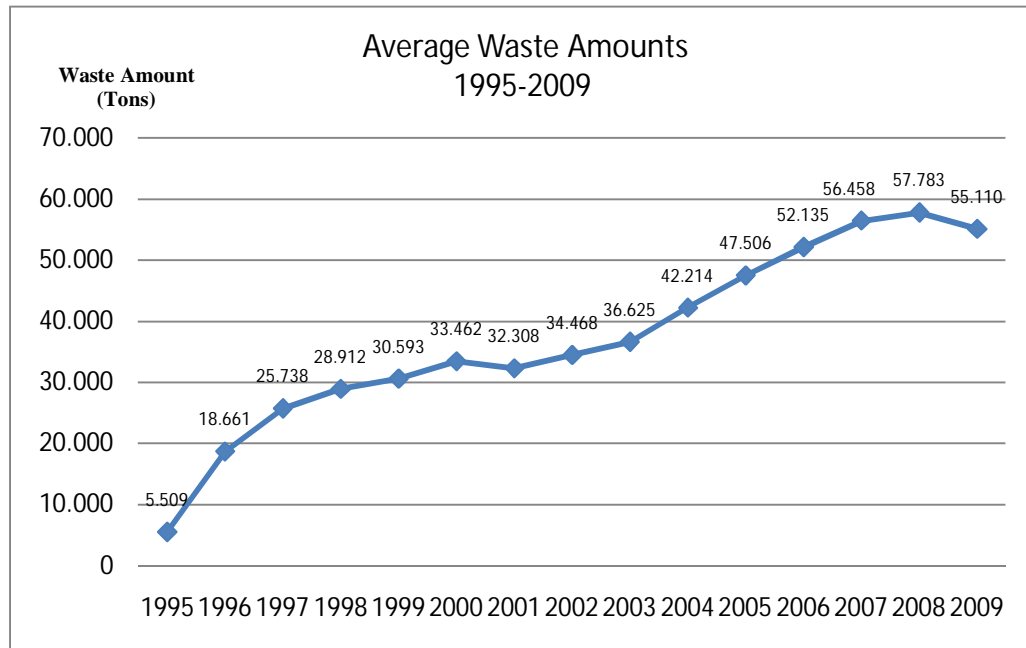

Figure 8.12. Monthly averages (EPCA, 2010)

### 8.5. Gas and Electricity Potential of Geçit Sanitary Landfill

Geçit Sanitary Landfill consists of three valleys. Waste storage has been completed in X and T valleys at the end of 1996 and 2000 respectively. Approximately 1,573,000 tons of solid wastes have been stored in these two valleys. Main valley which has begun to store on October, 2000 is already continuing to waste disposal. More than five millions of tons of solid wastes have been disposed and according to EPCA, Bursa Metropolitan Municipality; it is expected to reach 22 millions of tons of solid waste at the end of 2025 (Figure 8.13).

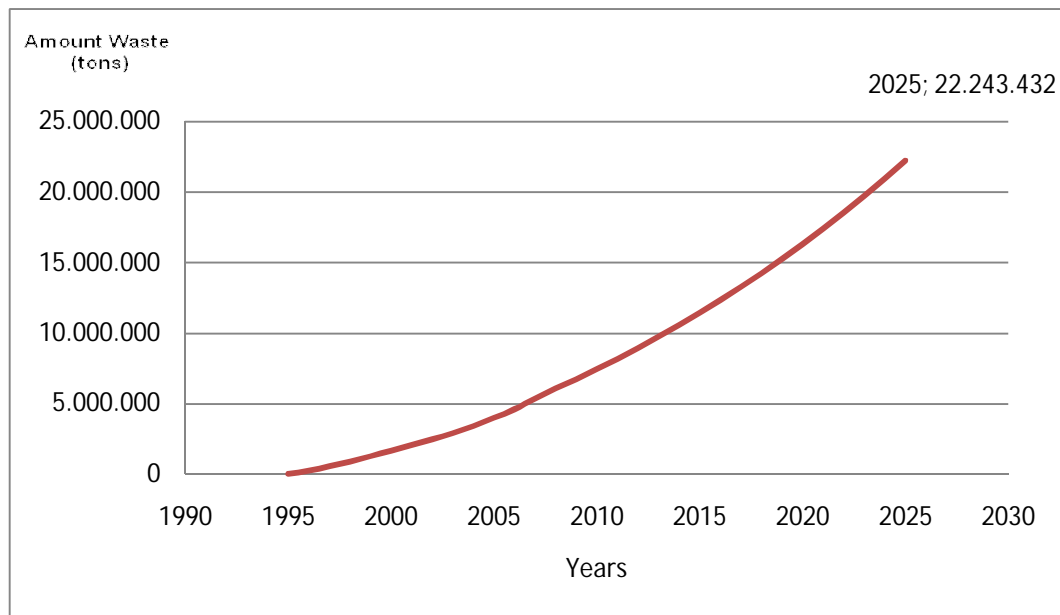

Figure 8.13. Landfilled solid waste projection of forthcoming fifteen years (EPCA, 2010)

### 8.5.1. Model Estimates

There are lots of gas estimation models such as LandGEM (Landfill Gas Emission Model), First Order model and Tabasaran/Rettenberger. As it is mentioned in chapter five, in literature after Test manholes most accurate results can be obtained from LandGEM gas emission model.

*8.5.1.1. Model of LandGEM (EPA).* LandGEM (EPA) model is developed to estimate of the amount of emissions of gases, in solid waste landfill site, causing of air pollution. Model is based on a first degree decomposition reaction. It is admitted that landfill gas is compose of half of methane and carbon dioxide. However, very low concentrations of other pollutants are taken into consideration as well. For prediction of any solid emissions from waste landfill sites, such information is needed:

- a. The design capacity of storage area (The amount of waste that can be disposed in storage)
- b. The average amount of waste stored in the field to the present or annual waste storage capacity
- c. Methane formation rate (k)

- d. Potential methane generation capacity ( $L_0$ )
- e. The year storage area is to be used since
- f. Hazardous waste stored with municipal solid waste at the site or not

The equation used in the model is a first degree decomposition reaction;

$$Q_{CH_4} = L_0 * R * (e^{-kc} - e^{-kt}) \quad (8.1)$$

where

$Q_{CH_4}$	= methane generation amount on time t, ( $m^3/year$ )
$L_0$	= potential methane generation capacity, ( $m^3 CH_4/$ tons of waste)
$R$	= annual stored waste during landfill storage lifetime, (tons/year)
$k$	= methane generation constant, ( $year^{-1}$ )
$c$	= year after landfill closed, (year) ( $c=0$ , if storage continues)
$t$	= elapsed time since first stored year, (year)

The most important parameters in this model are, methane formation constant ( $k$ ) and methane formation potential ( $L_0$ ). In the model calculation of emissions according to two different standards designed and the selection is up to user. One CAA (Clean Air Act) and this set of regulations are based on the applicability of the  $k$  value of  $0.05 \text{ year}^{-1}$  and  $L_0$  170  $m^3/ton$  are considered. The other one that called AP-42 (U.S. EPA Compilation of Air pollutant Emission Factors), and  $L_0 = 100$ ,  $k = 0.04 \text{ year}^{-1} \text{ m}^3/ton$  are considered. All of these values can be changed by the user and instead of that the data can be used obtained in experiments (USEPA, 1996).

8.5.1.2. First Order Model. The effect of depletion of carbon in the waste through time is accounted for in a first-order model. LFG formation from a certain amount of waste is assumed to decay exponentially in time (Scharff and Jacobs, 2006).

The first order model can be described mathematically by;

$$\alpha_t = \zeta * 1.87 * A * C_0 * k_l * e^{-k_l t} \quad (8.2)$$

where

$\alpha_t$	= LFG gas production at a given time, (m <sup>3</sup> /year)
$\zeta$	= dissimilation factor 0.58
1.87	= conversion factor, (m <sup>3</sup> LFG*kgC <sup>-1</sup> <sub>degraded</sub> )
$A$	= amount of waste in place, (Mg)
$c$	= amount of organic carbon in waste (kgC*Mg waste <sup>-1</sup> )
$k_l$	= degradation rate constant 0.094 (year <sup>-1</sup> )
$t$	= elapsed time since first depositing (year)

8.5.1.3. Tabasaran/Rettenberger. It is developed by Tabasaran and Rettenberger to calculate gas generation amount. It shows a cumulative increasing. In order to compare with other models result value  $G_t$  has to be multiplied by amount of waste deposit and subscribe values from the year before.

The Tabasaran/Rettenberger model can be described mathematically by;

$$G_t = 1.868 * G_{org} * (0.014T + 0.28) * (1 - 10^{-kt}) \quad (8.3)$$

where

$G_t$	= Cumulative LFG gas production at a given time, ( $m^3/ton$ )
$G_{org}$	= organic carbon content ( $kg/ton$ )
$T$	= temperature ( $^{\circ}C$ )
$k$	= degradation rate constant ( $year^{-1}$ )
$t$	= elapsed time since first depositing (year)

Most important subject in using models, is choosing the parameters.  $G_{org}$  value is 80-170  $kg/ton$  for municipal wastes. However taking the tested site values will be the more accurate results. Temperature is around 25-30  $^{\circ}C$  in stem of landfill body. The degradation constant changes in range of 0.04-0.08 (Akpınar, 2006).

Figure 8.14a and 8.14b shows the estimated LFG amounts in Kemerburgaz and Geçit between three gas models. In Kemerburgaz there were 115 active wells at the end of first half of 2009. Wells averagely drilled 30-35 meters depth. More than seven millions of tons of solid waste are considered to be used to generate electricity and to make a comparison such part of site is considered to be closed in 2009. Organic carbon content of waste is considered as 200 in both Tabasarran and First Order model. Potential methane generation capacity is taken as 40  $m^3$  in LandGem. According to İSTAÇ records, 20,127,427  $m^3$  of LFG is given to the Ortadoğu Energy to generate electricity in 2009 (İSTAÇ, 2010). Testing wells has showed that LandGem is the most reasonable model that approaches the real values in Kemerburgaz Sanitary Landfill project (Figure 8.14a).

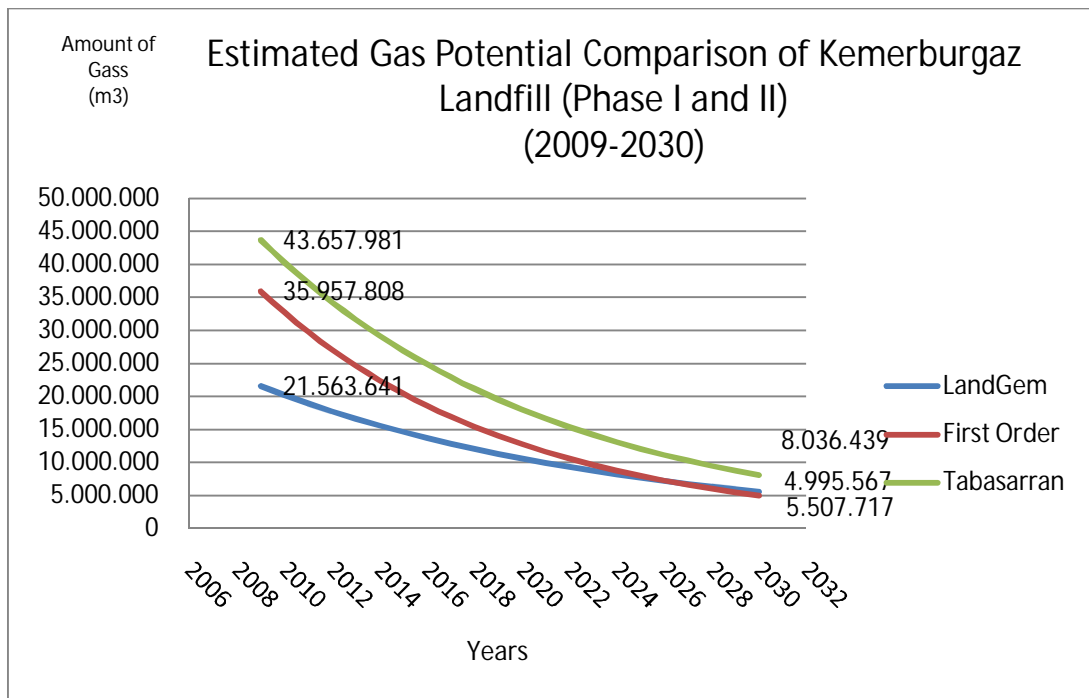

Figure 8.14a. The estimated LFG comparison in Kemberburgaz between three gas models

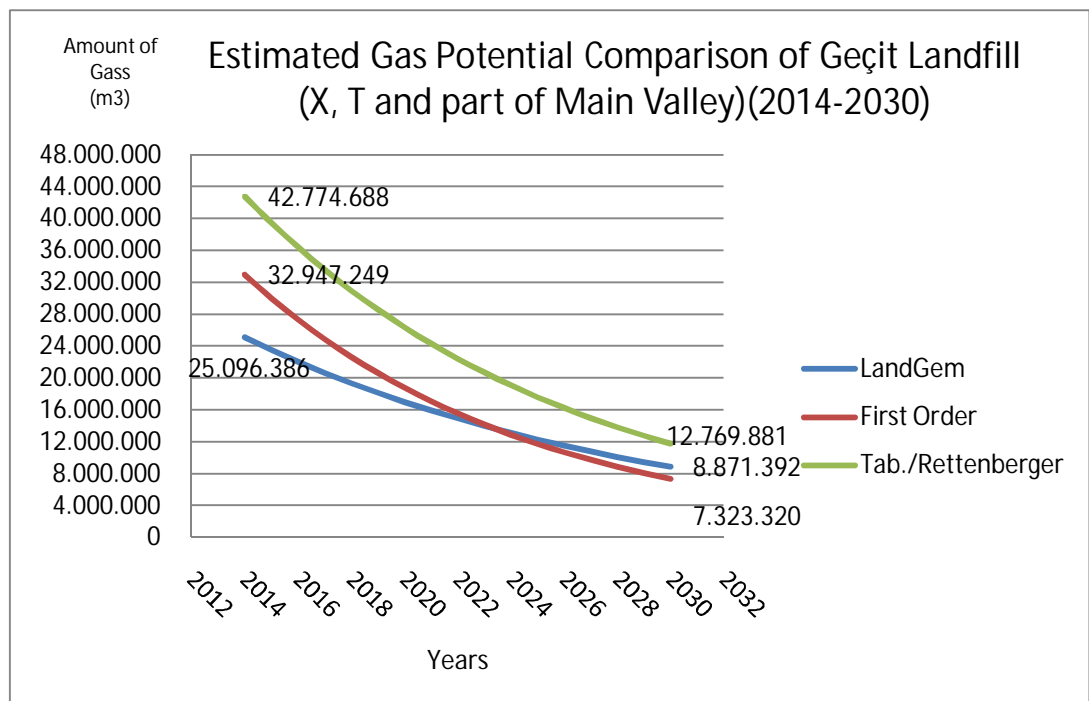

Figure 8.14b. The estimated LFG comparison in Geçit between three gas models

### 8.5.2. Estimated Gas Potential of Geçit

According to the experiment results done in solid waste in İstanbul, average methane generation potential of 1g of dry solid waste is 0.32 L and it proportions to wet solid waste. Result is 40 m<sup>3</sup> methane/tons of waste and used as methane generation potential (L<sub>0</sub>) in the model (Öztürk, 2008).

Because of this; although parameters methane generation constant (k) and potential methane generation capacity (L<sub>0</sub>) depends on climatic properties of region (Table 8.11), experiments results give lower values that help us to approach more accurate amounts of gases. So L<sub>0</sub> parameter is taken as 30 m<sup>3</sup> CH<sub>4</sub>/ tons in Bursa. Lower temperature and precipitation values have been considered while choosing this value compare to the Kemerburgaz.

Table 8.11. Potential Methane Generation Capacity (L<sub>0</sub>) and Methane Generation Constants (Öztürk, 2008)

<b>Annual Rainfall (mm/year)</b>	<b>L<sub>0</sub> (m<sup>3</sup>/ton)</b>	<b>k (year<sup>-1</sup>)</b>
0-249	60	0.040
250-499	80	0.050
At least 500	84	0.065 (500-999)
At least 1000	-	0.080

First phase of storage is finished in 2000 and second phase of main valley is expected to finish in 2014. According to all of this information LandGEM Gas Emission Model (EPA) that we have already discussed and compared with other models gives us the graphic that can be seen in Figure 8.15.

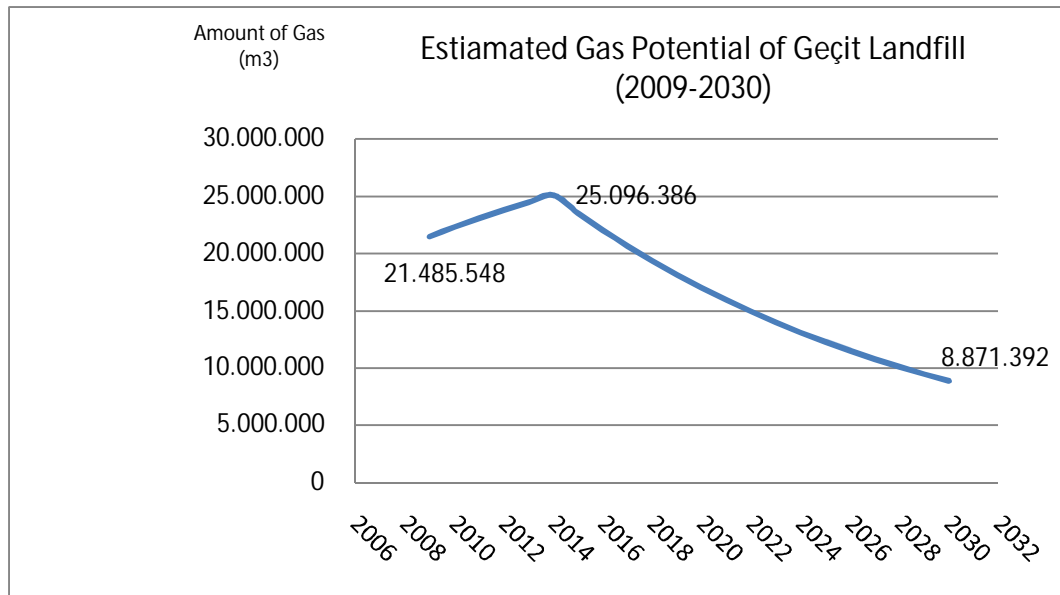

Figure 8.15. Gas potential projection of Geçit Sanitary Landfill

### 8.5.3. Electricity Potential of Landfill Gas in Geçit

Bursa is Turkey's fourth largest city with a population of 2,550,645 (Turkish Statistical Institute, 2009). According to report of Turkish Electricity Transmission Company (TEİAŞ, 2007), electricity request in Turkey will rise 6.3 to 8.2 (Low and High Scenarios) year by year. According to TEİAŞ rise expectations 2006 consumption values has been projected to 2009. Monthly electricity consumption values of Bursa can be seen in Table 8.12.

Ten per cent of this total electricity consumption has been provided from fossil fuels and the others from natural gas. Landfill storage is already continuing and finished and covered parts are X and T valleys.

Table 8.12. 2009 Electricity Consumption Values of Bursa, (UCTEA, 2007)

<b>Electricity Consumption Values of Bursa (2009)<sup>8</sup></b>		
<b>Months</b>	<b>Consumption (MWh)</b>	<b>Load Factor (%)</b>
January	711.097	62,92
February	783.940	69,36
March	886.687	78,45
April	822.703	72,79
May	874.754	77,4
June	843.329	79,07
July	885.205	78,32
August	932.994	82,55
September	896.367	79,31
October	833.414	73,74
November	894.648	79,16
December	920.629	81,46
<b>Total</b>	<b>10.285.767</b>	

In application of İstanbul Kemerburgaz Odayeri Facility shows that gen-set gas internal combustion machines operate 8,000 hr/year and can generate 2.5 KWh electricity from 1 m<sup>3</sup> landfill gas. From these valleys approximately 53GWh and 63GWh electricity can be obtained on 2009 and 2014 respectively. It means 6 pieces of 1.44 MW Jenbacher (GE) brand internal combustine machines are adequate.

According to this information, in this phase, 8.6 MW install capacity is adequate to generate 63,000 MWh energy on peak year, 2014 (Figure 8.16). It is 6.3 per cent of 1,000 GWh fossil fuel based electricity generation.

---

<sup>8</sup> Values are projected according to TEİAŞ Ten Years Electricity Production Capacity Report.

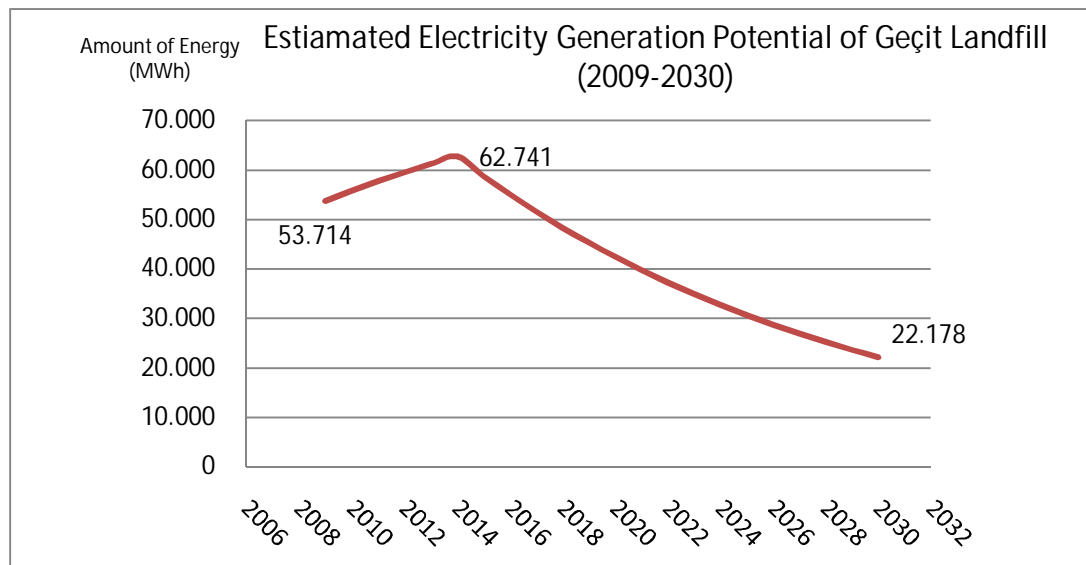

Figure 8.16. Electricity potential projection of Geçit Sanitary Landfill

#### 8.5.4. Carbon Emission Potential of Landfill Gas in Geçit

A thermal station with 1,000 MW power operates 6000-8000 hours/year, 2.5 million tons of coal is consumed and 6,000,000 tons of CO<sub>2</sub> gas is exhausted to the nature (Öztürk, 2009). In Bursa, approximately one million MWh electricity, which is ten per cent of total city's electricity consumption, has been obtained from fossil fuel.

In brief, to generate 7,000 GWh energy 2.5 million tons of coal have to be consumed and as a result 6 millions of tons of carbon exhausting occurs from fossil fuel based electricity generation. If electricity generation facility establishes in Bursa, there will be 53,778 tons of carbon emission reduction when land fill has reach the maximum storage value on 2014. Figure 8.17 shows the estimated carbon emission reduction amounts in consequence of energy production from solid waste instead of fossil fuel.

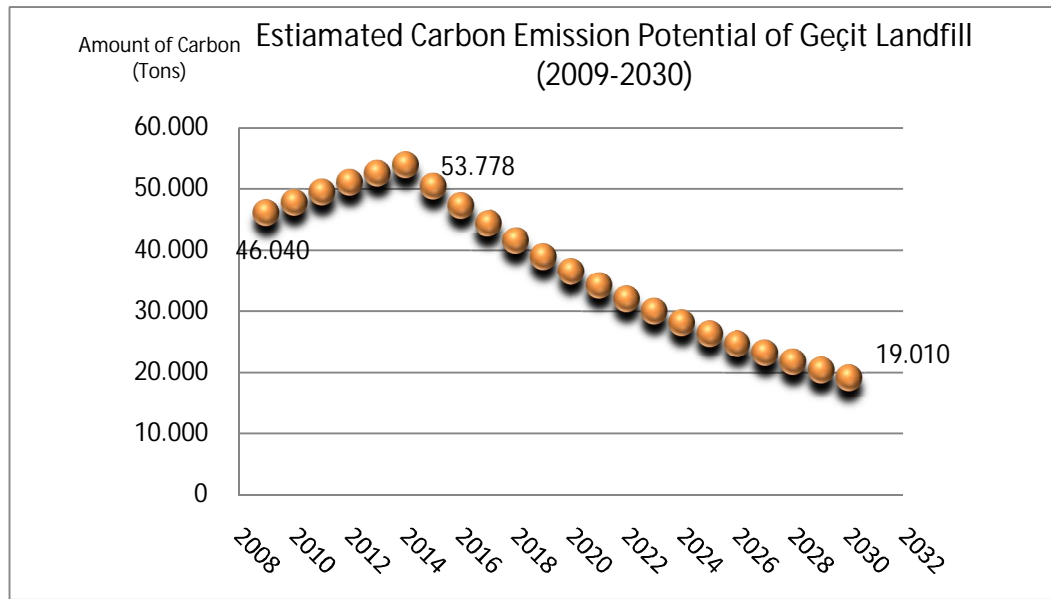

Figure 8.17. Estimated carbon emission reduction amounts in consequence of energy production from solid waste instead of fossil fuel

### 8.5.5. Economic Valuation

It is considered that generate electricity is possible by use of internal combusting machines just like Istanbul Kemerburgaz Odayeri Electricity Production Facility. It was considered eight Jenbacher gen-sets are adequate with working 8000 hrs/year and each one operates 1.44 MW electric power. Each one is nearly 1,250,000 EUR and first year investment cost is expected 2,500,000 USD includes; boilers, burners, pumps, manifolds, pipe lines and project prices.

Approximately fifty people work. Gen-sets are subjected to periodic maintenance in place by twice a year. Responsibility belongs to distributor of Gen-sets in Turkey. Also one technician from company works in facility permanently like Kemerburgaz Facility.

Electric purchase guarantee price has been taken 0,10 USD as an average of last two years (EPDK, 2010). Carbon contract revenue has been taken into account and considered 8 USD/tons according to average prices of 2009. In year 2010, economic valuation of the project with these approximations is shown in Table 8.13 and 8.14 respectively.

Table 8.13. Total Income Expectation in 2010

Total Electrical Energy Income	5.500.000 USD/year
Carbon Contract Income	430.000 USD/year
<b>Total Annual Income</b>	<b>5.930.000 USD/year</b>

Table 8.14. Total Expenditure Expectation in 2010<sup>9</sup>

Personal Expenses	40.000 USD/year
Consulting	30.000 USD/year
Insurance	75.000 USD/year
Operation and Maintenance	55.000 USD/year
Treatment Plant	750.000 USD/year
TEİAŞ System Price	25.000 USD/year
Miscellaneous	20.000 USD/year
<b>Total Annual Expenditure</b>	<b>995.000 USD/year</b>

<sup>9</sup> Values are estimated and approximations are similar as İstanbul-Kemberburgaz Project.

## 9. CONCLUSIONS

In parallel to the development of population, urbanization and industrialization, the generated solid waste amount increases with the same ratio. Generated solid wastes are disposed with the most common practices; either in open dumps or in sanitary landfills. The impacts of landfills to the environment are known by today and these impacts are controlled and overcome by the sanitary landfill operations. Processes occurring in landfills have a considerable importance in knowing and controlling the environmental impacts.

Turkey has great potential with its metropolises. Istanbul is the largest metropolis of Turkey and it has already got two of bioelectricity facilities. In Kemerburgaz Sanitary Landfill 58 hectares is using for landfilling. More than 31 millions of tons of solid waste is filled since 1995 and nearly seven millions of all amount is utilizing to generate electricity with 115 drilled gas extraction wells. New wells are opening and used site is developing day by day. İstaç Aş. gave 20,127,427 m<sup>3</sup> of volume of LFG to the generation plant and they produced 50,667,983 KWh electricity in 2009 (İSTAÇ, 2010). To predict forecast of LFG, used mathematical estimation gave results. Potential methane generation capacity is taken as 40 m<sup>3</sup> in LandGem. Although it is considered as 100-170 m<sup>3</sup> in literature; due to the improper filling applications and MSW mixing with construction wastes in the early of 1995, first parts of site will give too less amount of gas. According to the results LandGem (AP-42) accepted most suitable estimation model in İstanbul Kemerburgaz (Figure 8.14a). Due to the both demographic and climatic similarities Kemerburgaz Sanitary Landfill constitute a good example to Bursa Geçit. And also both landfilling site is begun to filling with platform system on 1995.

Second phase of Main Valley of Geçit Sanitary Landfill is intended to close at the end of 2014. LandGem (AP-42) was applied to the Geçit and estimated potential was predicted (Figure 8.15). LFG based electricity potential and carbon emission reduction potential instead of fossil based electricity generation were also estimated (Figure 8.16 and 8.17). According to the results it is possible to generate 6.3 per cent of 1,000 GWh fossil fuel based electricity necessity of Bursa in 2014. And more than 50 millions of tons of carbon emission reduction can be provided with using such a bioelectricity facility instead

of fossil fuel based thermal plants. At the end of both İstanbul - Kemerburagaz and Bursa - Geçit Landfill projects an economic valuation has been made.

Biomass has an important share in the renewable energy so that it will play a significant role for bioelectricity generation in the future with expanding technologies and power projects. Biomass can be a component of an increasingly based on renewable resources in Turkey. A significantly bioelectricity penetration will depend on the competitiveness of bioelectricity with other electricity sources and competition between alternative uses of biomass such municipal solid waste biomass. Turkey should take action for removing power dependency of abroad, reducing environmental damaged caused by fossil fuel, encouraging renewable energy.

## REFERENCES

- Akpınar, N., 2006, *Energy Production from Municipal Solid Waste*, M.S. Thesis, Istanbul Technical University.
- Aksoy, G., 2009, “Electricity Generation from Landfill Gas”, *International Waste to Energy Symposium Proceedings Book*, Istanbul, Turkey, 12-13 November, pp.8-11.
- DSI, 2010, General Directorate of State Hydraulic Works, *General Information about Istanbul*, <http://www.dsi.gov.tr/bolge/dsi14/index.htm>
- EPCA, 2010, Municipality of Metropolis Bursa, Environmental Protection and Control Agency, Bursa, Turkey.
- EPDK, 2010, Energy Market Regulation Authority, *Wholesale Sales Schedule*, <http://www.epdk.gov.tr/tarife/elektrik/toptansatis/toptansatistarife.html>
- Eren. E., 2009, “Funding of Renewable Energy Investments, TKB”, *International Waste to Energy Symposium Proceedings Book*, Istanbul, Turkey, 12-13 November, pp.122-124.
- Gülsoy, M., 2009, “Financing of Waste to Energy Investments, TSKB”, *International Waste to Energy Symposium Proceedings Book*, Istanbul, Turkey, 12-13 November, pp.108-111.
- Gülüt, Y.K., 2009, “Istanbul Ortadogu Enerji A.S. Energy from LFG Project”, *International Waste to Energy Symposium Proceedings Book*, Istanbul, Turkey, 12-13 November, pp.4-7.
- İSTAÇ AŞ, 2010, “İstanbul Çevre Yönetimi Sanayi ve Ticaret A.Ş 2009-2010 Yılı Verileri”, Istanbul, Turkey.

- İSTAÇ AŞ, 2007, "Report of Characterization of Solid Waste and Waste Mapping of Istanbul", *İstanbul Çevre Yönetimi Sanayi ve Ticaret A.Ş.*, Istanbul, Turkey.
- Kiriş, A. and F. Saltabaş, 2009, "Generation Utilization of LFG from MSW Landfills, Bioelectricity Generation from Biomass", *International Waste to Energy Symposium Proceedings Book*, Istanbul, Turkey, 12-13 November, pp.31-34.
- Kumar, S., 2000, "Technology options for municipal solid waste-to-energy project", *TERI Information Monitor on Environmental Science*, Vol. 5, No. 1, pp. 1-11.
- McBean, E.A., F.A. Rovers and G.J. Farquhar, 1995, *Solid Waste Landfill Engineering and Design*, Prentice Hall PTR, New Jersey, USA.
- McDougall, F., P. White, M. Franke, and P. Hindle, 2001, *Integrated Solid Waste Management: A Life Cycle Inventory*, Blackwell Science, Cornwall, Great Britain.
- Nag, A. and K. Vizayakumar, 2005, *Environmental Education and Solid Waste Management*, New Age International Publishers, New Delhi, India.
- Öztürk. M., 2008, "Methane Generation in Sanitary Landfill", *Integrated Solid Waste Management*, June, pp. 118–120.
- Öztürk. M., 2009, "Voluntary Carbon Trading", *Carbon Trading Market*, March, pp. 98–101.
- Scharff, H. and J. Jacobs, 2006, *Applying guidance for methane emission estimation for landfills*, Third Intercontinental Landfill Research Symposium, Vol. 26, Issue 4, pp. 417-429.
- Tchobanoglous, G., H. Theisen and S.A. Vigil, 1993, *Integrated Solid Waste Management: Engineering Principles and Management Issues*, McGrawHill, International Editions.

TEİAŞ, 2007, “Report of Projection of Ten Years Electricity Production Capacity in Turkey”, *Turkish Electricity Transmission Company*, Ankara, Turkey.

Turkish State Meteorological Service, <http://www.dmi.gov.tr/veridegerlendirme/il-ve-ilceler-istatistik.aspx?m=ISTANBUL>.

Turkish Statistical Institute, 2009, “Address Based Population Registration System Population Census Results”, *Prime Ministry*, Republic of Turkey.

UCTEA, 2007, “Report of Marmara Energy Forum”, *The Chamber of Electrical Engineer*, Ankara, Turkey.

USEPA, 1995, O’leary, P.R. and P.W. Walsh, “Decision Maker’s Guide To Solid Waste Management”, *United States Environmental Protection Agency Publication*.

USEPA, 1996, Orlic, M. and T. Kerr, “A Guide for Methane Mitigation Projects: Gas to Energy at Landfills and Open Dumps”, *United States Environmental Protection Agency Publication*.

USEPA, 1997, “Turning a Liability into an Asset: A Landfill Gas-to-Energy Project Development Handbook”, *United States Environmental Protection Agency Publication..*