

**A STUDY ON STABILITY OF FILL
ON CLAY SUBSOIL**

THESIS

Eser Tezulas

BOĞAZIÇI UNIVERSITY
Civil Engineering Department
1982

A STUDY ON STABILITY OF FILL ON CLAY SUBSOIL

by

Eser Tezulaş

(B.S., C.E. Boğaziçi University, 1978)

Thesis Submitted to the Faculty of Engineering
of Boğaziçi University
in
Partial Fulfillment of
the Requirements for the Degree of
Master of Science
in
Civil Engineering

Bogazici University Library



3900110031572

14

BOĞAZIÇI UNIVERSITY

1982

BOĞAZIÇI UNIVERSITY

BOĞAZIÇI UNIVERSITY

ACKNOWLEDGEMENTS

I would like to express my sincere gratitude to Doç. Dr. Turan H. Durgunoğlu for his encouragement, guidance and invaluable suggestions throughout the course of my study, without of which it would not be possible.

I also wish to thank to Prof. Dr. Vahit Kumbasar and Doç. Dr. Selçuk Erden for their invaluable suggestions.

A STUDY ON STABILITY OF FILL ON CLAY SUBSOIL

ABSTRACT

The procedures, assumptions and equilibrium methods used to develop the slope stability charts and detailed analysis procedures of stability are investigated during the first phase of the thesis.

The stability of a cohesionless fill on a clay foundation using Ordinary Method of Slices and Bishop's Modified Procedures of stability analysis are examined on the second phase of the thesis. For this purpose the effects of the shear strength parameters of the fill and subsoil clay foundation on the factor of safety are investigated. Furthermore the effect of variation in fill unit weight on stability and the stability of the fill on normally consolidated clay foundation whose shear strength is linearly varying with depth are also evaluated. For practical use, charts giving the variations of factor of safety with dimensionless parameters are also developed.

Key words: Slope stability, fill, clay subsoil.

KİL TEMEL ZEMİN ÜZERİNDEKİ DOLGUNUN STABİLİTESİ ÜZERİNE BİR ÇALIŞMA

Ö Z E T

Şev stabilite abakları ve detaylı stabilite analizleri ile ilgili prosedürler, varsayımlar ve denge metotları tezin ilk kısmında sunulmuştur.

Bir kum dolgunun, kil temel zemini üzerindeki stabilite analizinin basit dilimler metodu ve Bishop Modifiye metodu ile incelenmesi tezin ikinci kısmını oluşturmaktadır. Bu amaçla dolgunun ve kil temel zemininin kayma mukavemetlerinin emniyet katsayısı üzerindeki tesirleri incelenmiştir. Dolgu birimi ağırlığının değişimi ve normal konsolide olmuş temel kilinin kayma mukavemetinin derinlikle değişmesi halleri de gözönünde tutulmuştur. Pratik kullanımlar için, emniyet katsayısının boyutsuz parametrelerle olan değişimi abaklar halinde geliştirilmiştir.

Anahtar Kelimeler: Şev stabilitesi, dolgu, kil temel zemini.

TABLE OF CONTENTS

	<u>PAGE</u>
I. INTRODUCTION	1
2. SOLUTIONS USING SLOPE STABILITY CHARTS	4
2.1. Introduction	4
2.2. $\phi = 0$ Soils, With Constant Shear Strength With Depth	5
A. Procedures Used	5
Culman Method	6
Circular Shear Surfaces	8
The $\phi = 0$ Method	8
Average Shear Stress on Circular Shear Surfaces	8
The Factor of Safety	10
Assumption in the $\phi = 0$ Procedure	11
Fellenius Toe Circle	12
Deep Circle	12
B. Solutions By Means of Charts	15
Taylor's Charts	15
Janbu's Charts	19
2.3. Charts for Slopes With Strength Increasing With Depth and $\phi > 0$ Hunter and Schuster's Chart	25
2.4. Stability of Slopes in Uniform Soils With $\phi > 0$	27
A. Procedures Used	27
Friction Circle Procedure	27
The Logarithmic Spiral Procedure	30
B. Solutions by Means of Charts	31
Taylor's Chart	31
Janbu's Charts	31
Logarithmic Spiral Stability Charts (Wrights Charts)	34
2.5. Stability Charts For Analyses With Pore Pressures	38
A. Janbu's Approximate Procedure	41
B. Bishop and Morgenstern Procedure	45
C. Lowe and Karafiath's Procedure	51
2.6. Slopes in Cohesionless Materials ($c=0$ soils)	53

	<u>PAGE</u>
3. THE MECHANICS AND EQUILIBRIUM METHODS OF DETAILED STABILITY ANALYSIS	57
3.1. Introduction	57
3.2. Procedures of Slices Satisfying Moment Equilibrium	58
A. Moment Equilibrium of a Circular Shear Surface	58
B. The Ordinary Method of Slices	63
C. The Role of Side Forces	65
D. Early Graphical Procedures	66
E. Numerical Formulation of Slice Equilibrium	66
F. Solution of Slice Equilibrium Equations	70
Bishop's Procedure	70
Bishop's Modified Procedure	72
Spencer's Procedure	73
Morgenstern and Price's Procedure	74
3.3. Procedures of Slices Satisfying Force Equilibrium	75
A. Side Force Assumptions	77
Use of the Moment Equation	77
Lowe and Karafiath's Assumption	77
Side Forces Parallel to the line of Trust	79
B. Lowe and Karafiath's Procedure	81
C. Corps of Engineers' Wedge Analysis	81
D. Janbu's Generalized Procedure of Slices	84
Janbu's Approach	85
E. Janbu et.al. Simplified Procedure	86
3.4. Conclusion	87
4. STABILITY OF FILLS ON SOFT FOUNDATIONS	89
4.1. Introduction	89
4.2. Effect of Fill Shear Strength. Constant Shear Strength of Subsoil	90
4.3. Effect of Constant Subsoil Shear Strength	101
A. Effect of Fill Shear Strength	107
B. Critical Circle Trajectories	107
C. Effect of Subsoil Shear Strength	107
D. Normalization of the Results.	108

	<u>PAGE</u>
4.4. Effect of Subsoil Shear Strength. Linear Variation of Subsoil Shear Strength	113
A. Effect of Fill Shear Strength	120
B. Critical Circle Trajectories	120
C. Effect of Subsoil Shear Strength	120
D. Normalization of the Resulty	123
4.5. Conclusion	123
5. SUMMARY AND CONCLUSIONS	125
REFERENCES	128
APPENDIX	131

LIST OF TABLES

	<u>PAGE</u>
Table 1.1. Charts used in Chapter 2	2
Table 2.1. Stability numbers (N_{cf}) for most critical and toe log spirals (Wright 1969)	37
Table 3.1. Equations and unknowns associated with complete slice equilibrium.	62
Table 3.2. Equations and unknowns associated with force equilibrium for each slice.	76
Table 4.1. Data for studying the effect of Fill material	94
Table 4.2. Summary of Results (for variable fill density)	95
Table 4.3. Summary of Results (for fixed fill density)	96
Table 4.4. Data for studying the effect of subsoil shear strength.	102
Table 4.5. Summary of results. (Variable shear strength of subsoil).	104
Table 4.6. Calculation of the stability number by use of bearing capacity failure criteria.	112
Table 4.7. Data for studying the effect of subsoil shear strength (Linear increase of subsoil shear strength with depth)	116
Table 4.8. Summary of results (Linear increase of subsoil shear strength with depth).	117
Tables A1-A30 Results of Computer runs	135-168

LIST OF FIGURES

	<u>PAGE</u>
Figure 2.1. Elements of the Culmann method.	7
Figure 2.2. Stresses along a circular shear surface	9
Figure 2.3. Fellenius toe circle	13
Figure 2.4. Variation of the stability number with respect to slope arc for Deep circle and Fellenius toe circle	14
Figure 2.5. Chart of stability number (Taylor, 1948)	17
Figure 2.6. Chart of stability number for the case of zero friction angle and limited depth (Taylor, 1948).	18
Figure 2.7. Figure illustrating the calculation of c_{av} and ϕ_{av}	20
Figure 2.8. Slope stability charts for $\phi = 0$ soils (Janbu, 1968)	21
Figure 2.9. Reduction factor for slope stability charts for $\phi = 0$ and $\phi > 0$ soils (Janbu, 1968).	22
Figure 2.10. Reduction factor for slope stability charts for $\phi = 0$ and $\phi > 0$ soils (Janbu, 1968)	23
Figure 2.11. Slope Stability charts for $\phi = 0$, and strength increasing with depth (Hunter and Schuster 1968).	26
Figure 2.12. Stresses for a circular shear surface	28
Figure 2.13. Slope stability charts for $\phi > 0$ soils (Janbu 1968)	29
Figure 2.14. Log spiral stability chart for toe circles. Total stress analysis (Wright 1969).	36
Figure 2.15. Comparison of log spiral stability numbers for toe and base spirals (Wright 1969)	39
Figure 2.16. Log spiral stability chart for slopes on a rigid base. Total stress analysis (Wright 1969)	40
Figure 2.17. Stability numbers for $r_u = 0.0$ and 0.6 by Lowe and Karafiath's procedure (Wright 1969)	42

Figure 2.18.	Stability numbers for $r_u = 0.0$ and 0.6 by the Modified Bishop and Spencer's procedures (Wright 1969).	43
Figure 2.19.	Comparison of the values of factor of safety calculated using Janbu's simplified approach with those calculated using more accurate procedures $r_u = 0.6$ (Wright 1969)	44
Figure 2.20.	Determination of dimensionless parameters m and n for Bishop and Morgenstern's procedure	46
Figure 2.21.	Stability chart for analysis with pore pressure (Bishop and Margenstern 1960)	47
Figure 2.22.	Stability chart for analysis with pore pressure (Bishop and Margenstern 1960)	48
Figure 2.23.	Stability chart for analysis with pore pressure (Bishop and Margenstern 1960)	49
Figure 2.24.	Relationships between the stability numbers (N_{cf}) and r_u for several procedures of analysis. $\lambda c\phi = 20$ (Wright 1969)	50
Figure 2.25.	Stability chart for effective stress analyses. Lowe and Karafiath's procedure (Wright 1969)	52
Figure 2.26.	Stability charts for infinite slopes (Duncan and Buchighani 1975)	55
Figure 3.1.	Imaginary slice representation for a circular shear surface	59
Figure 3.2.	Forces acting on a typical slice	60
Figure 3.3.	Forces acting on a typical slice with no side forces.	64
Figure 3.4.	Forces and locations involved in the equilibrium of an individual slice.	67
Figure 3.5.	Line of thrust and interslice normal forces for a typical shear surface.	78
Figure 3.6.	Line of thrust and midheight line for a typical shear surface	80
Figure 3.7.	Force equilibrium polygons	82

	<u>PAGE</u>
Figure 3.8. Corps of Engineers' Sliding Block Analysis	83
Figure 4.1. Geometry and soil properties for studying the effects of fill material	93
Figure 4.2. Variation of the factor of safety with respect to slope height and for variable unit weight by Ordinary Method of Slices	97
Figure 4.3. Variation of the factor of safety with respect to slope height and for variable unit weight by Bishop's Modified Method	98
Figure 4.4. Variation of the factor of safety with respect to slope height and for variable unit weight by Ordinary Method of Slices	99
Figure 4.5. Variation of the factor of safety with respect to slope height and for fixed unit weight by Bishop's Modified Method	100
Figure 4.6. Geometry and soil properties for studying the effects of constant and linearly varying shear strength of subsoil	103
Figure 4.7. Variation of the factor of safety with respect to constant shear strength of the subsoil by Ordinary Method of Slices	105
Figure 4.8. Variation of the factor of safety with respect to constant shear strength of subsoil by Bishop's Modified Method	106
Figure 4.9. Variation of the factor of safety with respect to dimensionless parameter, t , by Ordinary Method of Slices	109
Figure 4.10. Variation of the factor of safety with respect to dimensionless parameter, t , by Bishop's Modified Method	110
Figure 4.11. Figure illustrating the calculation of the slope of the shear strength, m , of the subsoil	114
Figure 4.12. Variation of the factor of safety with respect to slope of the subsoil shear strength, m , by Ordinary Method of slopes	118

Figure 4.13.	Variation of the factor of safety with respect to slope of the subsoil shear strength, m , by Bishop's Modified Method	119
Figure 4.14.	Variation of the factor of safety with respect to dimensionless parameter, k , by Ordinary Method of Slices	121
Figure 4.15.	Variation of the factor of safety with respect to dimensionless parameter, k , by Bishop's Modified Method	122
Figure A.1.	Geometry and circle centers considered for $H_f = 4$ m	132
Figure A.2.	Geometry and circle centers considered for $H_f = 6$ m	133
Figure A.3.	Geometry and circle centers considered for $H_f = 8$ m	134

LIST OF SYMBOLS

- a = Length of the moment arm for the weight force (W) about a selected point O (L)
- a_j = coefficient used to describe a stress distribution in terms of the coordinates x and y .
- A = dimensionless number
- B = dimensionless number
- c = cohesion in terms of total stresses (F/L^2)
- c' = cohesion in terms of effective stresses (F/L^2)
- c_{av} = average cohesion intercept. (F/L^2)
- c_b = cohesion at the elevation of the bottom of the slope for soils with strength increasing with depth (F/L^2)
- c_m or c_d = mobilized cohesion intercept (F/L^2)
- d = maximum distance between the shear surface and the chord of the shear surface, measured normal to the chord (L)
- D = depth factor
- E or E_j = total interslice normal force (F)
- E_o = horizontal force acting on the left of the first slice (F)
- E_n = horizontal force acting on the right of the last slice (F)
- $f(x)$ = distributional relationship assumed for the side force inclinations.
- F = factor of safety
- F_o = factor of safety calculated by a force equilibrium procedure with horizontal side forces
- Δg = distance between the location of the normal force and the center of the base of a slice (L)
- h = depth to the shear surface; height of an interslice boundary; (L)
- h_t = vertical distance between the line of thrust and the shear surface (L)
- H = slope height in general; depth of sliding mass measured vertically (L)
- H_o = height obtained by extrapolation of the linear variation of cohesion intercept upward (L)
- H_f = height of fill layer (L)
- H_s = height of subsoil clay layer (L)
- H_w = depth of water outside slope (L)

H'_w	= height of water within slope (L)
i	= angle
k	= dimensionless number depending on the values of m, h, γ_f and H_f
k_α	= dimensionless number depending on the values of α, ϕ and F .
ℓ	= length of a circular shear surface (L)
$\Delta\ell$	= length of the base of a particular slice (L)
L	= length of a plane shear surface (L)
m	= dimensionless number depending on the values of F and r_u , or the slope of the cohesion intercept (F/L^3)
M or M_j	= moment acting on an interslice boundary (FL); or height ratio.
M_o	= overall moment in balance about the center of a circular shear surface (FL)
n	= number of slices; or a dimensionless number depending on the values of F and r_u .
N	= normal force acting on a segment of the shear surface (F); or a stability number
N_{cf}	= Stability number
P_d	= dimensionless number depending on the values of $H, q, H_w, \gamma, \gamma_w, \mu_q, \mu_w$ and μ_t
P_e	= dimensionless number depending on the values of $H, H'_w, q, \gamma, \mu_q$ and μ'_w .
q	= surcharge (F/L^2)
r	= radial distance from the central point to a point on either a circular or logarithmic spiral shear surface; the radius of a circle (L)
r_u	= pore pressure coefficient
r_{ue}	= calculated pore pressure coefficient
s	= shear strength of a soil (F/L^2)
s_u	= undrained shear strength of a soil (F/L^2)
S	= shear force on the base of a slice (F)
t	= dimensionless number, depending on the values of c, H_f and γ_f .
T	= distance from the depth of sliding to the surface of the slope, measured normal to the surface of the slope (L)
u	= pore water pressure (F/L^2)
w	= angle

- W = weight of an entire soil mass bounded by an assumed shear surface and the slope surface; or the weight of an individual slice (F)
- Δx = width of a slice (L)
- x_0 = unit center abscissa (L)
- X = distance from the depth of sliding to the surface of seepage, measured normal to the surface of the slope (L)
- X_0 = vertical force acting on the left of the first slice (F)
- y_0 = unit center ordinate (L)
- y_s = y coordinate of a point of the shear surface (L)
- y_t = y coordinate of a line of thrust (L)
- z = depth of subsoil from which the critical circle passes (L)
- Z = resultant of all forces acting on an interslice boundary (F)
- α = angles
- β = angles
- γ = total unit weight of soil (F/L³)
- γ_f = total unit weight of fill (F/L³)
- γ_s = total unit weight of subsoil (F/L³)
- γ_w = unit weight of water (F/L³)
- δ = angles
- θ = angles
- μ_q = surcharge correction factor
- μ_w = submergence correction factor
- μ'_w = seepage correction factor
- μ_t = tension crack correction factor
- λ = scaling factor for side force inclinations, used in the Morgenstern and Price procedure for slope stability analysis.
- $\lambda_{c\phi}$ = dimensionless parameter used to describe a particular slope in terms of c, ϕ, γ and H .
- $\lambda'_{c\phi}$ = modified dimensionless parameter used in making stability analysis with pore pressures.
- σ or σ_n = normal stress on a selected plane (F/L²)
- τ = shear stress on a selected plane (F/L²)
- τ_m = mobilized shear stress (F/L²)
- ϕ = the angle of internal friction for a soil mass in terms of total stresses.
- ϕ_{av} = average angle of internal friction.

Table 1.1- Charts Used in Chapter 2

Charts Used	Type of Soil				
	(1)	(2)	(3)	(4)	(5)
Culmann Method (1866)	Yes*				
Fellenius Toe circle(1928)	Yes*				
Deep circle	Yes*				
Taylor's charts (1948)	Yes		Yes		
Janbu's charts (1968)	Yes		Yes		
Hunter and Schuster's charts (1968)		Yes			
Wright's charts (1969)			Yes		
Janbu's approximate procedure(1967)				Yes	
Bishop and Morgenstern procedure (1960)				Yes	
Lowe and Karafiath's procedure(1960)				Yes	
Duncan and Buchignani's chart(1975)					Yes

(1) $\phi = 0$ soils, with constant shear strength with depth.

(2) Soils with strength increasing with depth and $\phi = 0$

(3) $c - \phi$ soils

(4) analysis of soils with pore pressures

(5) $c = 0$ soils

* Closed form formulation is given

The procedures of analysis which have been described in Chapter 2 are similar in that they consider only the equilibrium of soil mass bounded by the shear and slope surfaces. In contrast to these procedures, many other techniques of analysis have been developed in which the soil mass is divided vertically into a number of slices and are known as procedures of slices. The solutions of these procedure require some assumptions, detailed hand calculations or use of computer, but they have the advantage to solve the slope stability problem for all types of soils and complicated soil profiles. In Chapter 3 the procedures of slices namely the procedures of slices satisfying the moment equilibrium such as Ordinary Method of Slices, Bishop's procedure (1955), Bishop's Modified procedure, Spencer's procedure (1967), Morgenstern and Price's procedure (1965, 1967) and the procedures of slices satisfying the force equilibrium such as Lowe and Karafiath's procedure (1960), Corps of Engineers' Wedge analysis (1968), Janbu's Generalized procedure of Slices (1957, 1968), and Janbu's simplified procedure (1956) are discussed, and some of the procedures listed above are used in the analysis of Chapters 2 and 4.

The stability of a cohesionless fill on a clay foundation using Ordinary Method of Slices and Bishop's Modified Procedures of stability are examined in Chapter 4. For this purpose the effects of the shear strengths parameters of the fill and subsoil clay foundation on the factor of safety are investigated. Moreover the effect of variation in fill unit weight on stability and the stability of the fill on normally consolidated clay foundation whose shear strength is linearly varying with depth are also evaluated. For practical use, charts giving the variations of factor of safety with dimensionless parameters are also developed on Chapter 4.

2. SOLUTIONS USING SLOPE STABILITY CHARTS

2.1. INTRODUCTION

Besides the field observations and the detailed analysis, the stability charts is one of the method to solve the slope stability problems. Although its common use was the preliminary design calculation, charts are now available which make it possible to perform quite accurate analyses for many conditions, and they provide perhaps the most convenient method of analysis for simple homogeneous slopes cases.

By the appropriate use of dimensionless numbers these stability charts are considerably simplified. The use of stability number for slope analysis has been first introduced by Fellenius (1927). The stability charts introduced by Fellenius simplified considerably the iterations to calculate the factor of safety for $\phi = 0$ soils.

Using the stability charts one can also back-calculate the strength values for the failed slopes to be used in

planning remedial measures.

This chapter is a collection of slope stability charts concerning $\phi = 0$ soils, with constant shear strength with depth by Taylor's and Janbu's charts, of charts for slopes with strength increasing with depth and $\phi > 0$ by Hunter and Schuster's chart, of charts for stability of slopes in uniform soils with $\phi > 0$ by Taylor's, Janbu's and logarithmic spiral stability charts of Wright, of chart for stability analysis with pore pressures by Janbu's, Bishop and Morgenstern and Lowe and Karafiath's charts, of charts for slopes in cohesionless materials by Duncan and Buchignani's chart. The procedures satisfying overall moment of equilibrium such as Culman method, circular shear surface, the $\phi = 0$ method, Fellenius toe circle method, deep circle method, friction circle procedure, the logarithmic spiral procedure are summarized.

2.2. $\phi = 0$ SOILS, WITH CONSTANT SHEAR STRENGTH WITH DEPTH

In this section the slope stability of the $\phi = 0$ soils with constant shear strength is discussed by the slope stability charts and the procedures by means of which these charts are developed are revised.

A. Procedures Used

Many procedures of slope stability analysis have been developed which employ the conditions of static equilibrium to calculate the average value of shear strength required to prevent failure. The differences between these various procedures of analysis relate to the assumptions that are made in order to achieve statical determinacy and the particular conditions of equilibrium that are satisfied.

The procedures of Culman's Method, Circular Shear surfaces such as $\phi = 0$ method, Fellenius toe circle and deep

circle are summarized in this subsection.

The Culmann Method

The Culmann Method (1866) is based on the assumption that failure occurs on a plane through the toe of the slope. Figure 2.1. represents the type of section to which this analysis applies. The forces that act on the mass above a trial failure plane, at an inclination defined by the angle θ , are also shown in the figure. The expressions for the weight and the total cohesion are, respectively,

$$W = \frac{1}{2} \gamma LH \csc i \sin (i-\theta) \quad (2.1)$$

$$c = c_d / L \quad (2.2)$$

where

c_d = mobilized cohesion intercept, defined as the ratio of the cohesion intercept, c , to the factor of safety, F .

i = inclination of the slope

θ = angle between the horizontal plane and the trial failure plane

The stability number for the trial plane at the inclination, θ , is given by the expression

$$\left(\frac{cd}{H}\right)_{\theta} = \frac{1}{2} \csc i \sin (i-\theta) \sin (\theta-\phi_d) \sec \phi_d \quad (2.3)$$

where

ϕ_d = developed friction angle defined as

$$\tan \phi_d = \tan \phi / F$$

in which ϕ = internal friction angle

F = factor of safety

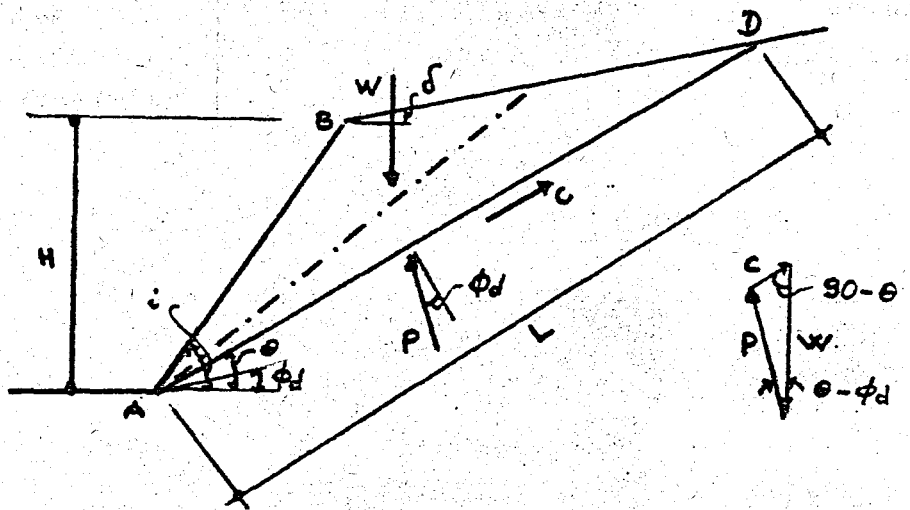

Fig. 2.1. Elements of the Culmann method

The most dangerous plane is that with the maximum stability number given by the expression

$$\frac{cd}{\gamma H} = \frac{1 - \cos(i-d)}{4 \sin i \cos \phi d} \quad (2.4)$$

Circular Shear Surfaces

Since the early 1900's, when an investigation of quay wall failures led Swedish engineers to the conclusion that an appropriate stability analysis could be based on the assumption of circular shear surfaces, many procedures of stability analysis have been developed which utilize the several advantages afforded by such surfaces. In addition to the fact that they approximate the shapes of failure surface observed in many actual slope failures, and they considerably simplify the geometry involved in defining and locating a critical shear surface, perhaps the most important advantage of using circular surfaces is their significant simplification of the mechanics of stability analyses.

The $\phi = 0$ Method

While the earliest procedures of stability analysis for circular shear surfaces assumed that the shearing resistance of the soil was due entirely to friction, in 1917, Hellan suggested that the shear strength of a clay could be treated entirely as a cohesion (Petterson, 1955; Bjerrum and Flodin, 1960). Combining this concept of the shear strength and the assumption of circular shear surfaces, Fellenius in 1918 proposed what is today commonly known as the " $\phi = 0$ " method of stability analysis, a procedure which is widely used for analysis of short-term slope stability.

Average Shear Stress on Circular Shear Surfaces

The average shear stress (τ_m) mobilized along the circular arc bpd shown in Figure 2.2. can be determined from

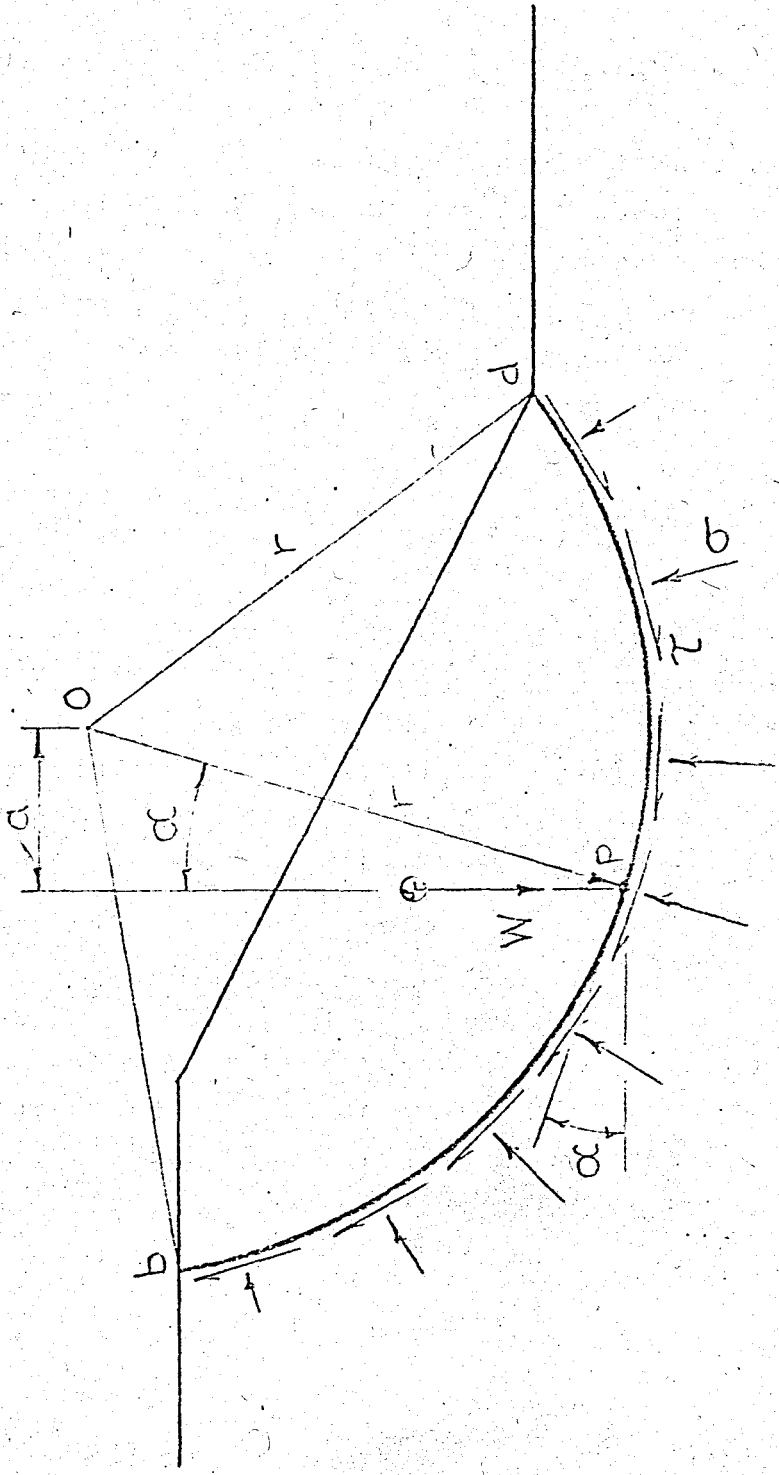

Fig.2.2. Stresses along a circular shear surface

the summation of moments about the center point (o). For a mass of soil in static equilibrium this sum must be zero. Thus

$$\Sigma M_o = W.a - \tau_m . \ell r = 0 \quad (2.5)$$

in which W is the weight of the soil mass overlying bpd, a is the length of the moment arm of W about O , ℓ is the length of the shear surface and r is the radius of the circle. By substituting $a = r \sin\alpha$, where α is the inclination of the shear surface at its intersection with the weight factor, the average shear stress can be expressed as,

$$\tau_m = \frac{W \sin\alpha}{\ell} \quad (2.6)$$

This equation for the average value of shear stress required for equilibrium of a circular arc is free of any assumptions. Regardless of what method is used to determine the equilibrium of the sliding mass shown in Figure 2.2 the average shear stress must be the same as that given by Fig. 2.6 as long as static equilibrium is satisfied.

The Factor of Safety

In many procedures for slope analyses, stability is measured in terms of an overall factor of safety with respect to shear strength. If the shear strength for the slope in Figure 2.2 is s_u , the factor of safety is defined by,

$$F = \frac{s_u}{\tau_m} \quad (2.7)$$

which, upon substituting the expression for τ_m , gives the factor of safety for a particular circular shear surface in terms of known geometry and soil conditions:

factor of safety is derived from the equation of the moment equilibrium.

Fellenius Toe Circle

Fellenius (1928) has calculated the shear strength, c , hence the stability number by using a toe circle, called Fellenius toe circle (presented in Figure 2.3) and he noted that the shear strength, c , depends on $\gamma h/4$, δ , α , ω . These variables are given in Figure 2.3 the also find a ratio, M ,

$$M = \frac{c_m \text{ plane}}{c_m \text{ circle}} \quad (2.9)$$

where

c_m plane : mobilized shear stress for plane failure surface (Culman's Method).

c_m circle: mobilized shear stress calculated by Fellenius Toe Circle

M values for different slope angle δ are given as follows:

Slope angle	10°	20°	30°	40°	50°	60°	90°
M	0.16	0.28	0.42	0.55	0.66	0.76	0.95

It may be observed that for low values of slope angle, M values is very low and for high values of slope angle ($\delta \cong 90^\circ$) M values approaches to the unity.

Deep Circle

When the deep circles case for $\phi = 0^\circ$ and $s = \text{constant}$ is studied, and when the radius of the circle is shifted up and down it is observed that the factor of safety, F , becomes independent of the slope angle for high values of the circle radius, and it is calculated by the following relationship:

$$C_m = \frac{\gamma H}{4} f(\delta, \omega, \alpha)$$

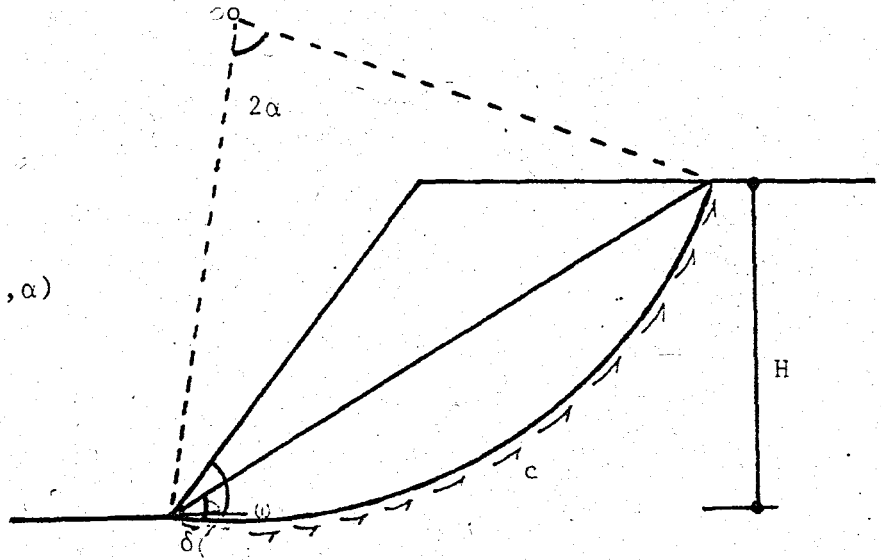

Fig 2.3. Fellenius toe circle

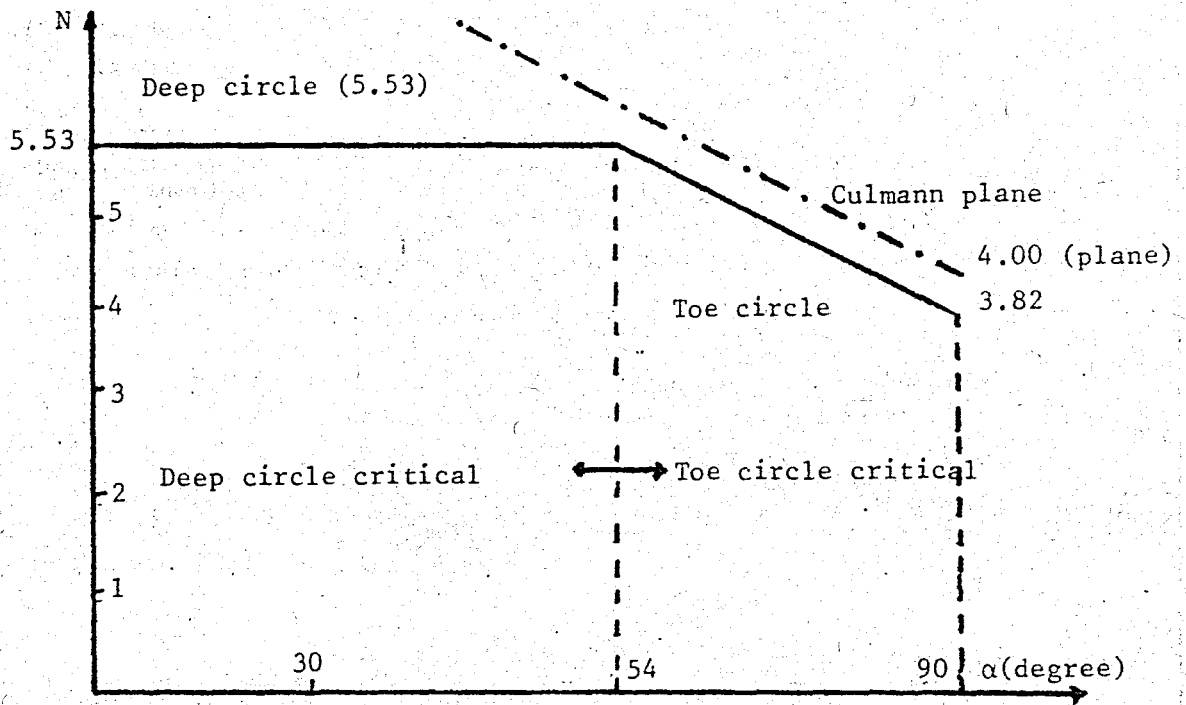

Fig. 2.4. Variation of the stability number with respect to slope arc for Deep circle and Fellenius toe circle

$$F = \frac{5.53 c_u}{\gamma H} \quad (2.10)$$

As can be seen from the Fig 2.4 for the values of α less than or equal to 54° deep circle is critical and for values of α greater than 54° Fellinius toe circle is critical. For the whole range in which deep circle is critical the stability number is constant and equal to 5.53.

B. Solutions by Means of Charts.

In this part of the study the slope stability for the $\phi = 0$ soils, with constant shear strength with depth is discussed by means of the Taylor's and Janbu's charts.

Taylor's Charts

Taylor (1948) has developed charts giving stability numbers whose solutions are valid only for the simple homogeneous finite slope, for cases involving no seepage.

Taylor proposed developed shear strength the parameters c_d and ϕ_d in terms of c and ϕ , where c_d , the mobilized cohesion and ϕ_d , the developed friction angle are defined respectively as:

$$c_d = \frac{c}{F} \quad (2.12)$$

$$\tan \phi_d = \frac{\tan \phi}{F} \quad (2.13)$$

According to Taylor (1948). the critical circle for steep slopes passes through the toe of the slope. This is shown by key sketch A in Figure 2.5. In zone B the critical circle is described, by three cases that are shown in key sketch B in Fig. 2.5. For small slope angles or small friction angles the critical circle may pass below the toe of

the slope. For all ranges in which this case holds, stability numbers are given in the chart by long dashed curves. Stability numbers for the most dangerous circles passing through the toe are given by solid lines in the chart both when there is and when there is not a more dangerous circles that passes below the toe: For the zero- ϕ case the critical circle passes below the toe of the slope with slope inclination of less than 53° . Theoretically the critical arc for this case goes to an infinite depth. However in practice, the depth at which the rupture occurs is usually limited by some strong strata. Thus the stability number for the zero- ϕ case is dependent on the limiting value of depth. To represent this condition the variable used is the ratio of depth of failure mass to height of slope; is designated as D by Taylor and is shown in Fig. 2.6. For various values of D and for zero- ϕ case the chart in Fig 2.6 supplements Fig 2.5.

These Charts are Used as Follows:

. If the inclination angle of the slope, i , is greater than 53° , the critical circle passes through the toe of the slope with the lowest point on the failure arc at the toe of the slope; than chart in Fig. 2.5. is used by the appropriate slope angle, i , and the developed friction angle $\phi_d = 0$. The stability number obtained is same as can be obtained by the Fellenius toe circle method.

. If the inclination angle of the slope, i , is less than 53° the chart in Fig. 2.6. can be used by knowing the corresponding depth factor, D, and the slope angle, i . These charts are applicable only to the extremely simple cases. However, many slopes that approximate the simple section and that are composed of more or less heterogenous soils may be subjected to an approximate analysis by entering the charts with average values.

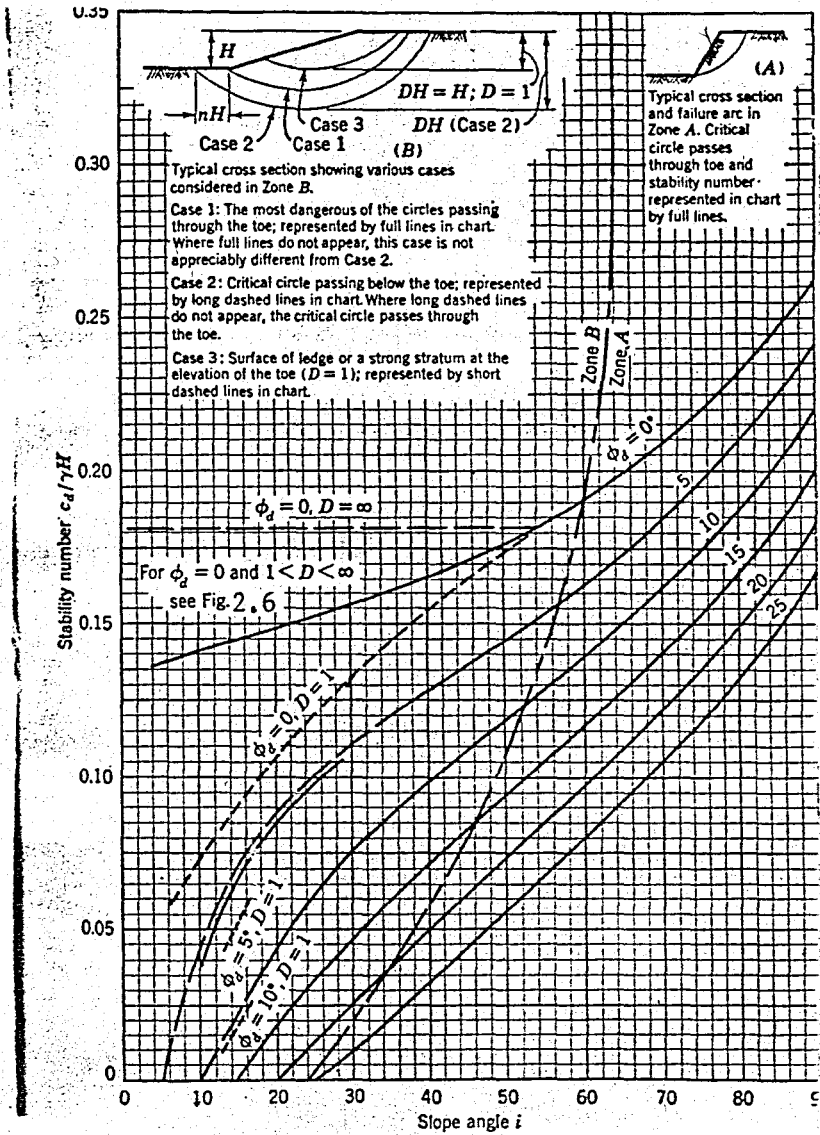

Fig.2.5. Chart of stability number (after Taylor, 1948)

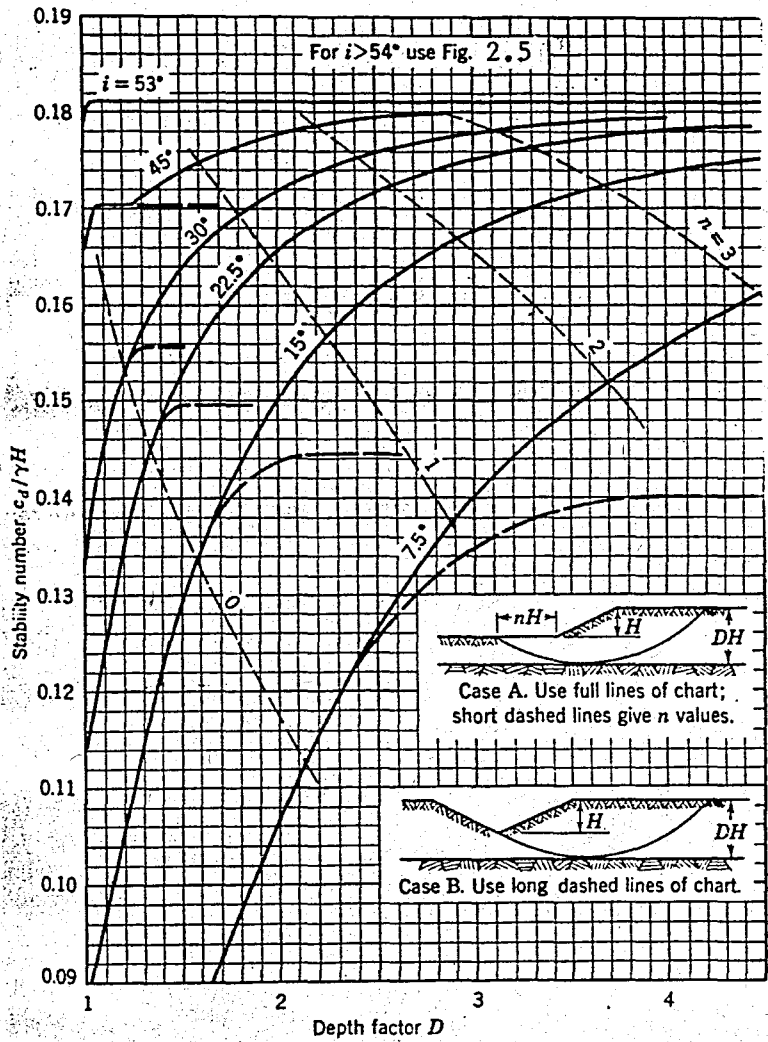

Fig.2.6. Chart of stability number for the case of zero friction angle and limited depth (after Taylor, 1948).

Janbu's Charts

Janbu (1968) has developed series of charts to calculate the stability number, N , for $\phi_u = 0$ and $c-\phi$ soils. These charts are more complicated than the Taylor's charts since they take into the account the effect of the surcharge on the slope, the effect of submergence and seepage, the effect of the tension crack for no hydrostatic pressure and full hydrostatic pressure in the crack.

The following procedure could be followed in using these charts:

1- The location of the critical circle can be estimated using judgement. The critical circle for slopes flatter than 53° will extend as deep as possible, and will be tangent to the top of some firm layer. The center of the circle is located on a line extending vertically upward from the center of the slope. The critical circle for slopes steeper than 53° will pass through the toe of the slope.

2- Using the estimated critical circle as a guide, the average value of the shear strength "c", can be estimated then the weighted average of the strengths along the failure arc is calculated. An example is shown in Fig 2.7.

3- The depth factor d , can be calculated using the formula

$$d = \frac{D}{H} \quad (2.14)$$

where

D = Depth from the toe to the lowest point on the slip circle

H = Slope height, as illustrated on Fig 2.8.

4- P_d could be calculated using the following relation-

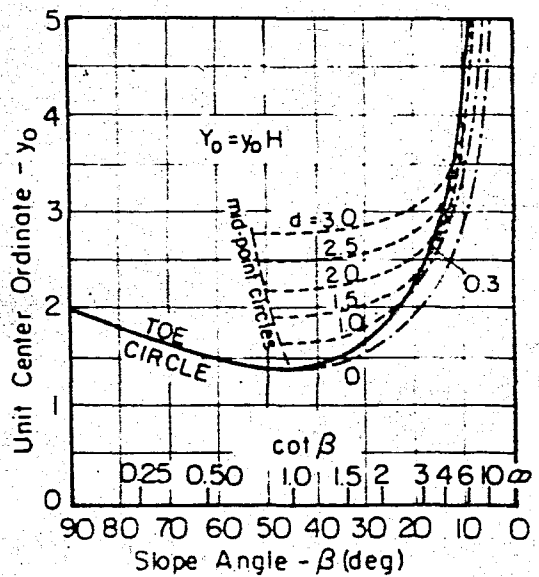
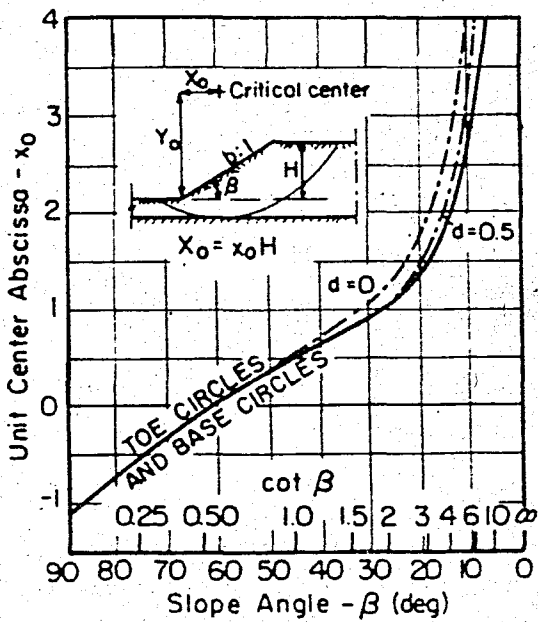
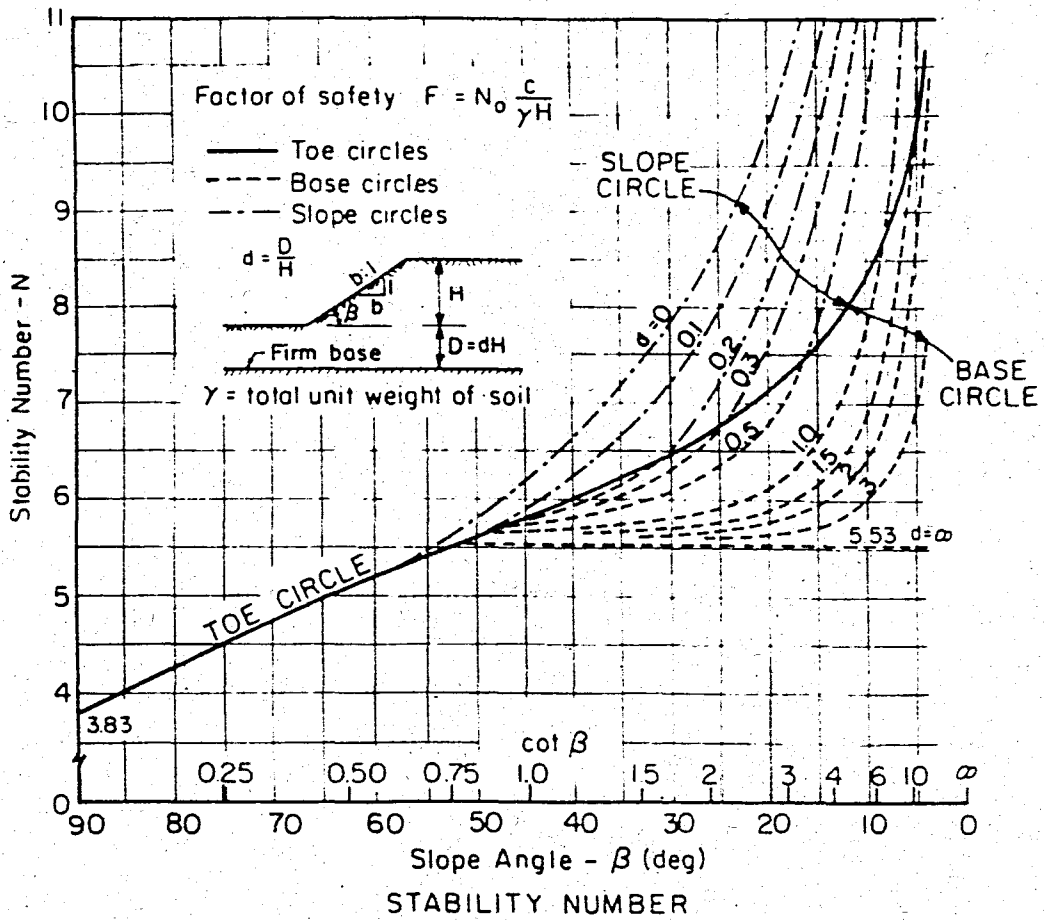

CENTER COORDINATES FOR CRITICAL CIRCLE

Fig. 2.8. Slope stability charts for $\phi = 0$ soils (after Janbu, 1968)

REDUCTION FACTORS FOR SURCHARGE

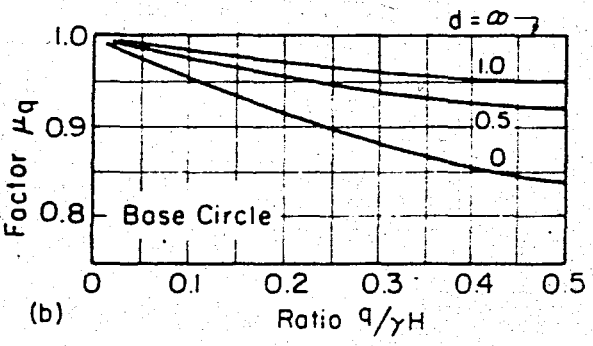
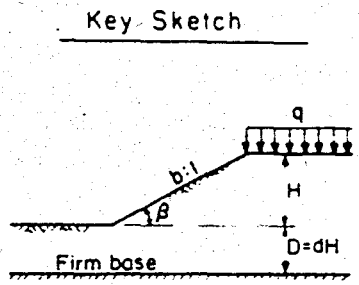
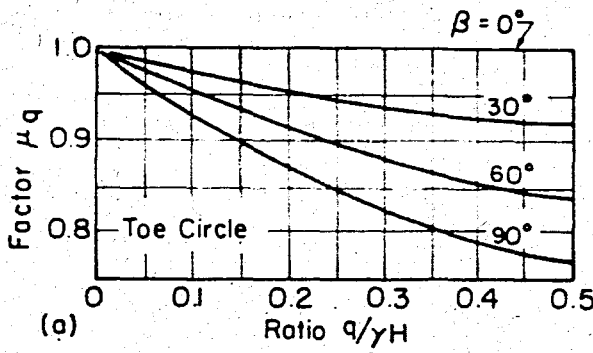

REDUCTION FACTORS FOR SUBMERGENCE (μ_w) AND SEEPAGE (μ'_w)

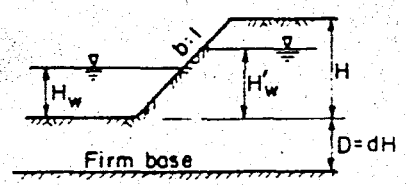
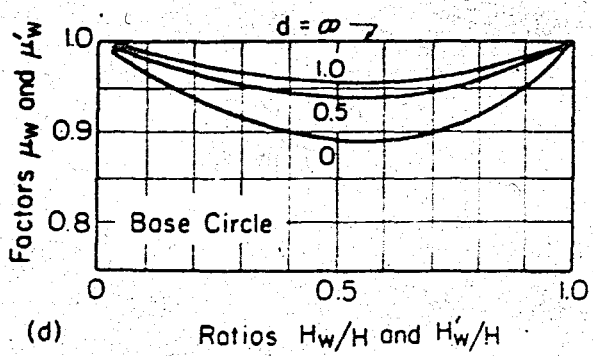
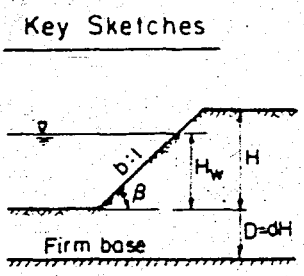
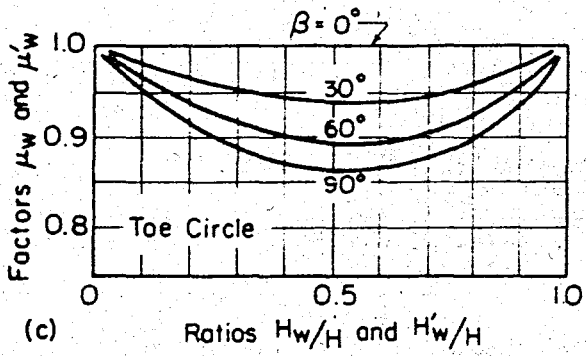
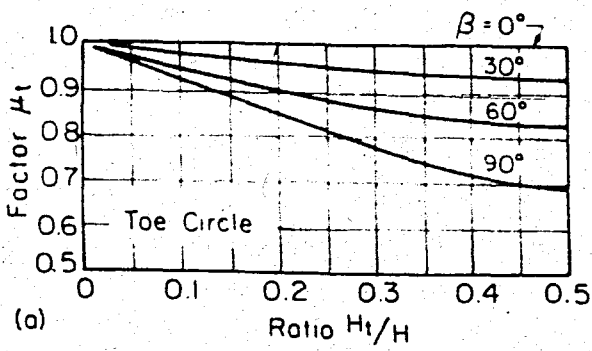
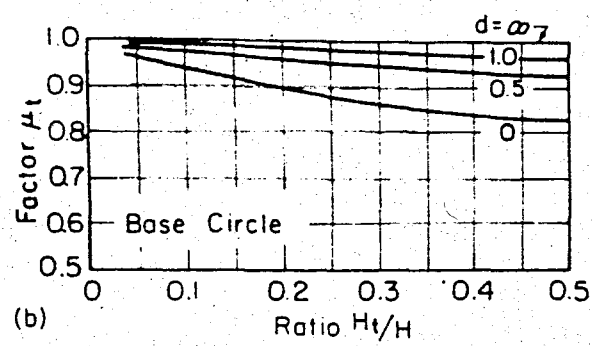

Fig.2.9. Reduction factors for slope stability charts for $\phi = 0$ and $\phi > 0$ soils (after Janbu, 1968)

REDUCTION FACTOR FOR TENSION CRACK
No Hydrostatic Pressure in Crack



(a)



(b)

Key Sketch

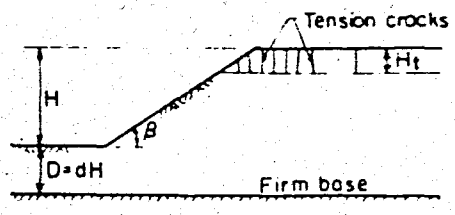

REDUCTION FACTOR FOR TENSION CRACK
Full Hydrostatic Pressure in Crack

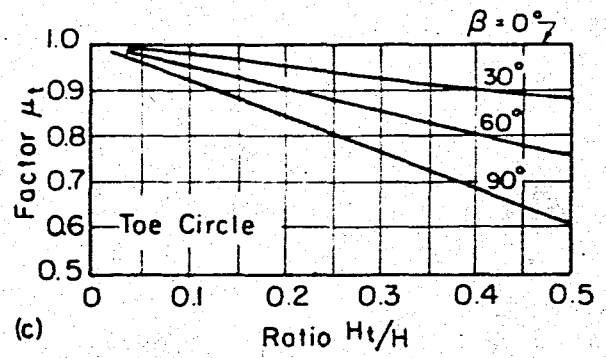

(c)

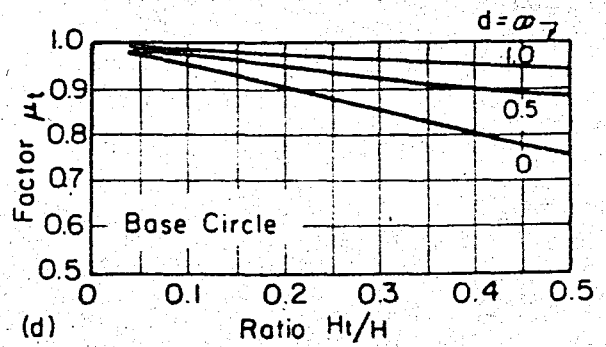

(d)

Key Sketch

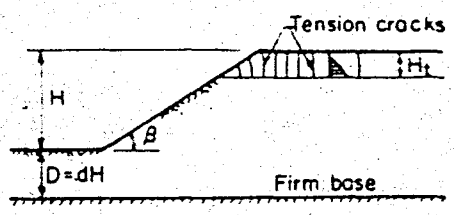

Fig. 2.10. Reduction factors for slope stability charts for $\phi = 0$ and $\phi > 0$ soils (after Janbu, 1968)

ship

$$P_d = \frac{\gamma H + q - \gamma_w H_w}{\mu_q \mu_w \mu_t} \quad (2.15)$$

where

- γ = average unit weight of soil
- H = slope height
- q = surcharge
- γ_w = unit weight of water
- H_w = depth of water outside slope
- μ_w = surcharge correction factor (Fig 2.9 top)
- μ_w = submergence correction factor (Fig 2.9 bottom)
- μ_t = tension crack correction factor (Fig 2.10)

5- Using the chart at top of fig 2.8 the stability number, N , can be determined as a function of slope angle, and the value of d .

6- The factor of safety, is calculated using the formula:

$$F = \frac{Nc}{P_d} \quad (2.15)$$

Where c is average shear strength determined.

7- The actual location of the critical circle can be determined using the chart at the bottom of Fig 2.8. If this critical circle is much different from the one assumed in step 1, for the purpose of determining the average strength, steps 2 through 7 should be repeated.

8- If a slope contains more than one soil layer, it may be necessary to calculate the factor of safety for circles at more than one depth as recommended by Duncan and Buchignani (1975).

. If a soil layer is weaker than the layer above, the critical circle will be tangent to the base of the lower layer.

. If the reverse is valid; the critical circle may be tangent to the base of either the upper or the lower layer; both possibilities should be examined.

2.3. CHARTS FOR SLOPES WITH STRENGTH INCREASING WITH DEPTH AND $\phi=0$

For normally consolidated clays the shear strength of the soil is not in general constant throughout of the layer, and when such a problem is tried to be solved a constant shear strength or linear variation of shear strength with depth should be taken into the account in the stability analysis. In this section the calculation of the stability number, N , for a variable shear strength case, by means of Hunter and Schuster (1968) is shown. The procedure is as follows:

1- Linear strength variation with depth which best fits the measured strength data is estimated.

2- The chosen linear variation must be extrapolated upward to determine H_0 , the height at which the strength profile intersects zero and the value of strength, c_b , at the bottom of the slope is determined.

3- The ratio $M = H_0/H$ is calculated where H = slope height.

4- The stability number, N , is determined from the chart in the Fig 2.11.

5- The factor of safety F is then calculated using the formula:

$$F = \frac{N c_b}{\gamma(H+H_0)} \quad (2.17)$$

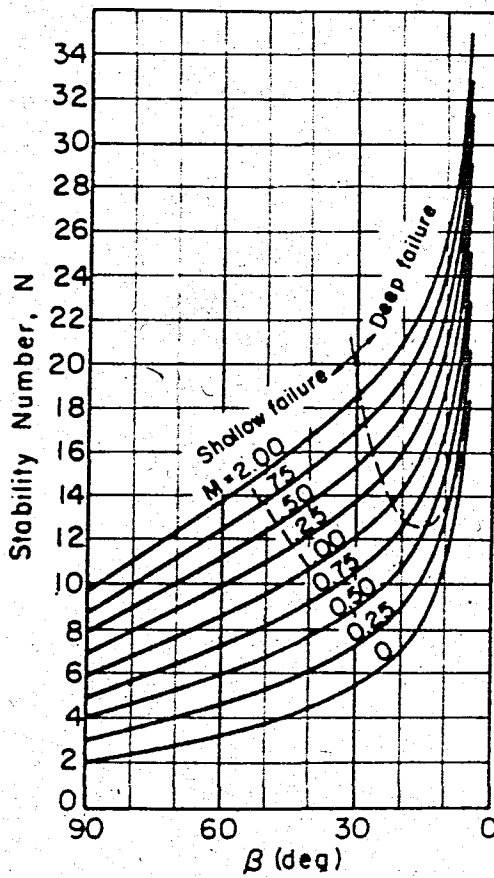
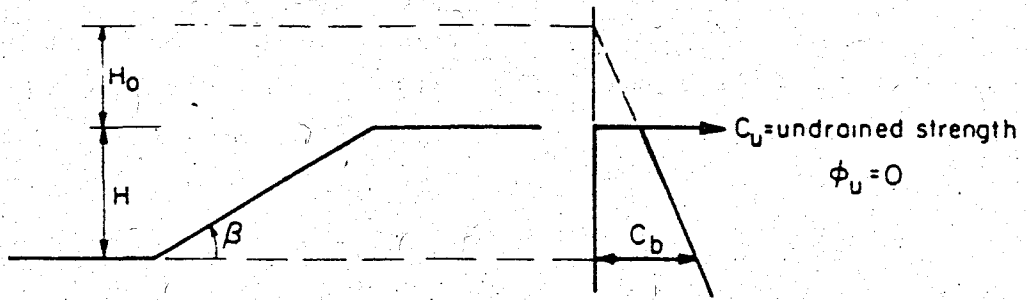

Fig. 2.11. Slope stability charts for $\phi = 0$, and strength increasing with depth (after Hontar and Schuster, 1968)

in which

γ = total unit weight of soil

γ = buoyant unit weight for submerged slopes

γ = weighted average unit weight for partly submerged slopes

2.4. STABILITY OF SLOPES IN UNIFORM SOILS WITH $\phi > 0$

In this section the slope stability of soils possessing both the cohesion intercept, c , and internal friction angle, ϕ values is discussed by the slope stability charts and the procedures by means of which these charts are developed are summarized.

A. Procedures Used

The procedures of Friction Circle and the logarithmic spiral which are applicable for such soils are summarized in this subsection.

Friction Circle Procedure

For a circular shear surface the resultants of the normal stresses (σ) and frictional component of shear resistance ($\sigma \tan \phi_m$) where ϕ_m is mobilized friction angle given by

$$\tan \phi'_m = \frac{\tan \phi}{F} \quad (2.13)$$

in which F is the factor of safety which lies tangent to a circle of radius $r \sin \phi'$, called the friction circle as shown in Fig 2.12. Consequently, the summation of moments about the center point of the circle shown in the figure will involve the normal stress distribution; and, because the unknown number of coefficients required to describe this distribution can't be evaluated from the three equations of equilibrium, the solution for the factor of safety is indeterminate. To

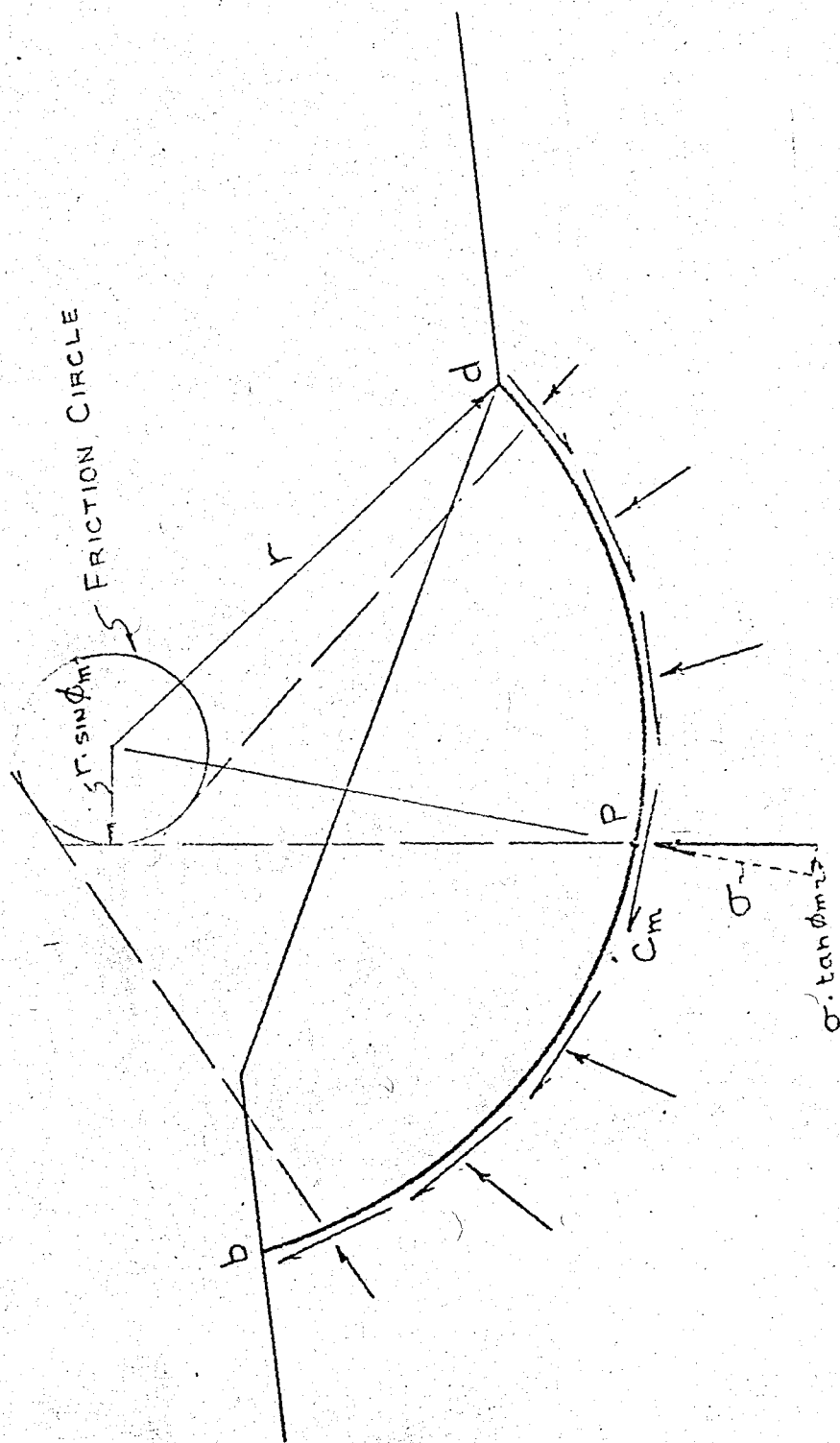
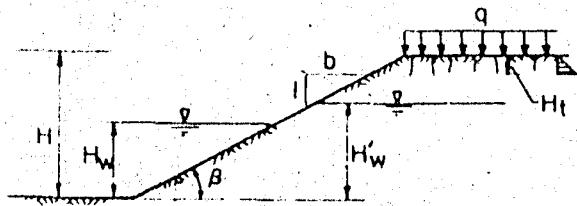
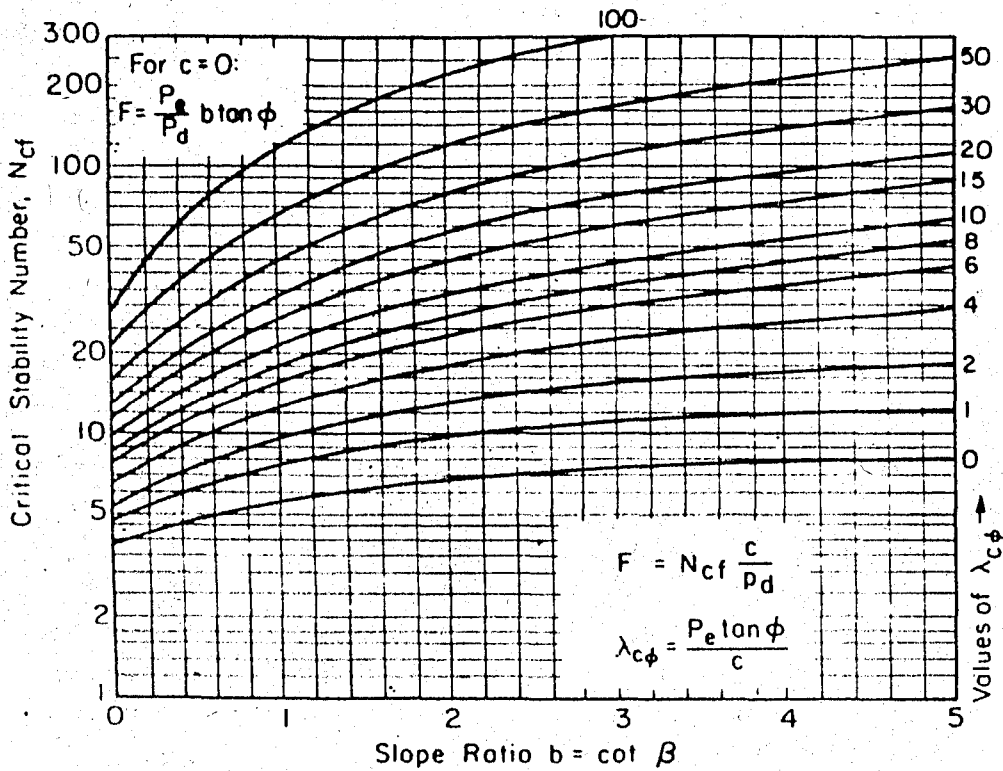

Fig. 2.12. Stresses for a circular shear surface



$$P_d = \frac{\gamma H + q - \gamma_w H_w}{\mu_q \mu_w \mu_t}$$

$$P_e = \frac{\gamma H + q - \gamma_w H_w'}{\mu_q \mu_w}$$

(In formula for P_e take $q=0$, $\mu_q=1$ for unconsolidated condition)

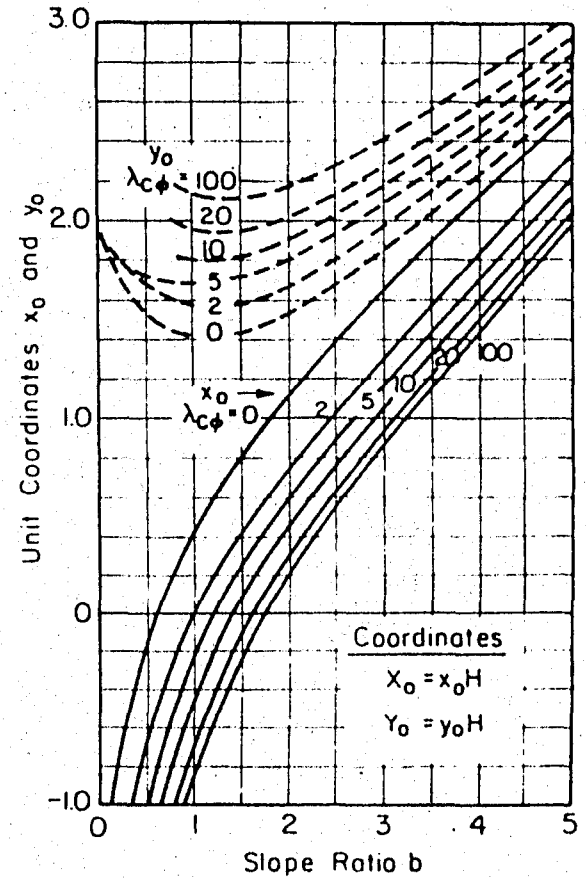

CENTER COORDINATES FOR CRITICAL CIRCLE

Fig.2.13. Slope stability charts for $\phi > 0$ soils (after Janbu, 1968)

achieve statical determinacy in the Friction Circle procedure of analysis it is assumed that the single resultant (R) of all normal stresses and frictional shear resistances lies tangent to the friction circle. The unknown magnitude and location of this resultant, and the unknown factor of safety may then be determined from the three available equilibrium conditions using either graphical or numerical techniques (Wright, 1969).

The Logarithmic Spiral Procedure

Although the assumption of a circular shear surface is insufficient to achieve statical determinacy when ϕ is not equal to zero, statical determinacy may be achieved by assuming a logarithmic spiral surface of the form:

$$r = r_o e^{\theta \tan \phi_m} \quad (2.18)$$

Where r is the radial distance from the center point to a point on the spiral, r_o is the reference radius; θ is the angle between r and r_o , and ϕ_m is the mobilized friction angle for the shear surface. Such a surface has the property that all the resultants of the normal stresses (σ) and frictional components of shear strength ($\sigma \tan \phi_m$) pass through the center point of the spiral and thus their contributions to the moments are equal and opposite. Consequently the moment equation will only involve the weight force and cohesive resistance of the soil.

By summation of moments about the center of the spiral, the average mobilized cohesion required for equilibrium may be calculated; however since a value of ϕ_m must be assumed before a shear surface may be defined by the above equation, the mobilized cohesion which is calculated may be result in a different factor of safety, F , with respect to cohesion than was assumed in calculating ϕ_m . Thus several trials must be made until a balanced F with respect to a shear strength can be found which satisfies the relationship:

$$F = \frac{c}{c_m} = \frac{\tan \phi}{\tan \phi_m} \quad (2.19)$$

B. Solutions By Means of Charts

In this part of the study the slope stability of the uniform soils with $\phi > 0$, is discussed by means of the Taylor's (1948), Janbu's (1968), and Wright's (1969) charts.

1- Taylor's Chart

The chart in Fig. 2.5 developed by Taylor (1948) and discussed on section 2.2 is also applicable for $c-\phi$ soils. According to Taylor the critical circle for steep slopes passes through the toe of the slope with the lowest point on the failure arc at the toe of the slope, as shown by key sketch A in Fig 2.5. In zone B the low point of the critical circle is not at the toe of the slope, and three cases that will be considered are shown in key sketch B in Fig 2.5. For small slope angles and for $c-\phi$ soils the critical circle may pass below the toe of the slope. For all ranges in which this case holds, stability numbers are given in the chart by long dashed curves. Stability numbers for the critical circles passing through the toe are given by solid lines in the chart.

2- Janbu's Charts

As for the $\phi = 0$ case Janbu (1968) has developed a chart for $c-\phi$ soils giving the stability number, N , which can be used with his previous charts (Fig 2.8 through 2.10) to determine the factor of safety for a given set of conditions.

Steps for use of Janbu's Charts are summarized below:

1- The location of the critical circle is estimated. In general the critical circle passes through the toe of the slope

and the critical stability numbers, N_{cf} , given as the ordinate of the chart in Fig 2.13 have been developed by analysing toe circles. One must be careful about the two cases stated below by Duncan and Buchignami (1975).

. If the soil conditions are not uniform and there is a weak layer beneath the toe of the slope, a circle passing beneath the toe may be more critical than a toe circle. In this case the chart in Fig 2.8 can be used provided that the values of "c" and " ϕ " used represent the correct values of the considered circle.

. A second and more important case is to have a weak layer above the toe of the slope where a circle passing above the toe of the slope becomes more critical. Similarly if there is water outside the toe of the slope, a circle passing above the water may be more critical. When these particular circles are analysed the value of H is equal to the height from the base of the weak layer, or the water level, to the top of the slope.

2- Using the estimated circle as a guide, the approximate average values of "c" and " ϕ " can be found by calculating the weighted average values of them along the failure arc as illustrated in Fig 2.7.

3- The parameter P_d can then be calculated as:

$$P_d = \frac{\gamma H + q - \gamma_w H_w}{\mu_q \mu_w \mu_t} \quad (2.20)$$

4- The parameter P_e is calculated from:

$$P_e = \frac{\gamma H + q - \gamma_w H'_w}{\mu_q \mu_w \mu_t} \quad (2.21)$$

where

H'_w = height of water within slope

μ'_w = seepage correction factor (Bottom of Fig 2.9)
and other factors are as defined previously.

If the surcharge is applied so quickly that there is not sufficient time for the soil to consolidate under surcharge the following values should be utilized: $q = 0$ and $\mu_q = 1$ in Eq 2.21.

5- The dimensionless parameter $\lambda_{c\phi}$ can be calculated as:

$$\lambda_{c\phi} = \frac{P_e \tan\phi}{c} \quad (2.22)$$

For $c = 0$, $\lambda_{c\phi} = \infty$, then step 5 is skipped.

6- Using the chart at the left in Fig 2.13 the value of the stability number, N_{cf} , can be determined as a function of slope angle β and the value of $\lambda_{c\phi}$.

7- The factor of safety F is calculated from

$$F = N_{cf} \frac{c}{P_d} \text{ for } c > 0 \quad (2.23)$$

$$F = \frac{P_e}{P_d} b \tan\phi \text{ for } c = 0 \text{ (} b = \cot \beta \text{)} \quad (2.24)$$

8- The actual location of the critical circle can be determined by using the chart on the right side of Fig 2.13. The coordinate of the center of the circle are X_0 , Y_0 and it is a toe circle, if the case examined differs from the exceptions stated below:

. If there is a weak layer beneath the toe, the

the critical circle passes tangent to the base of the weak layer.

. $\lambda_{c\phi} = \infty$, than the shallow sliding becomes the critical failure mechanism. as described later.

If the critical cricle is quite different from the one assumed, Steps 2 through 8 must be repeated to obtain the average strengths.

For nonhomogenous slopes, the following rules recommended by Duncan and Buchignani (1975) could be followed.

. If a slope contains more than one soil layer, it may be necessary to calculate the factor of safety for circles at more than one depth.

. If a soil layer is weaker than the layer above, the critical circle (toe or deep circle) will extend into the lower layer.

. If a soil layer is stronger than the layer above, the extention of the critical circle into the lower layer depends upon the relative strengths of the layer. Hence both possibilities have to be examined.

Logarithmic Spiral Slope Stability Charts - Wright (1969)

This method assumes the ruptre surface to be a logarithmic spiral. No further assumption is required to make the problem statically determinate, which constitutes the important advantage of the method. On the other hand, solutions based on spiral surfaces are not as easily handled by graphics or mathematics as are those based on circular arc. As in the circular arc method, all possible logarithmic spirals, passing either through or below the toe of the slope, should be investigated to locate the critical one. The logarithmic

spiral for zero ϕ case becomes circle and gives the same result with the circular arc methods. This procedure can be easily used for calculation of the stability number (N_{cf}) for slopes in homogeneous soils because regardless of the values the procedure fully satisfies all conditions of equilibrium independently of any assumptions regarding the normal stress distribution along the shear surface. The following procedure is adopted in using Wright's Chart.

1. The slope ratio, $\cot\beta$, is calculated.
2. The dimensionless parameter, $\lambda_{c\phi}$, is determined from.

$$\lambda_{c\phi} = \frac{\gamma H \tan\phi}{c} \quad (2.25)$$

where

- γ : Unit weight of the fill
- H : Slope height
- ϕ : Internal friction angle
- c : Cohesion intercept

3. Using the chart in Fig.2.14, provided by Wright (1969) the value of the stability number is determined for the critical log spiral shear surfaces passing through the toe of the slope.

4. The factor of safety is then calculated as:

$$F = N_{cf} \frac{c}{\gamma H} \quad (2.26)$$

Wright (1969) has shown that for relatively flat slopes with low values of $\lambda_{c\phi}$ a more critical spiral may be observed which cuts the surface beyond the toe of the slope. The stability numbers for these most critical surfaces are tabulated in Table 2.1. together with the values calculated for the critical toe circles. From this table it can be noted that even the difference in stability numbers of the most critical surfaces is less than 1-1/2 %. for steeper slopes with high

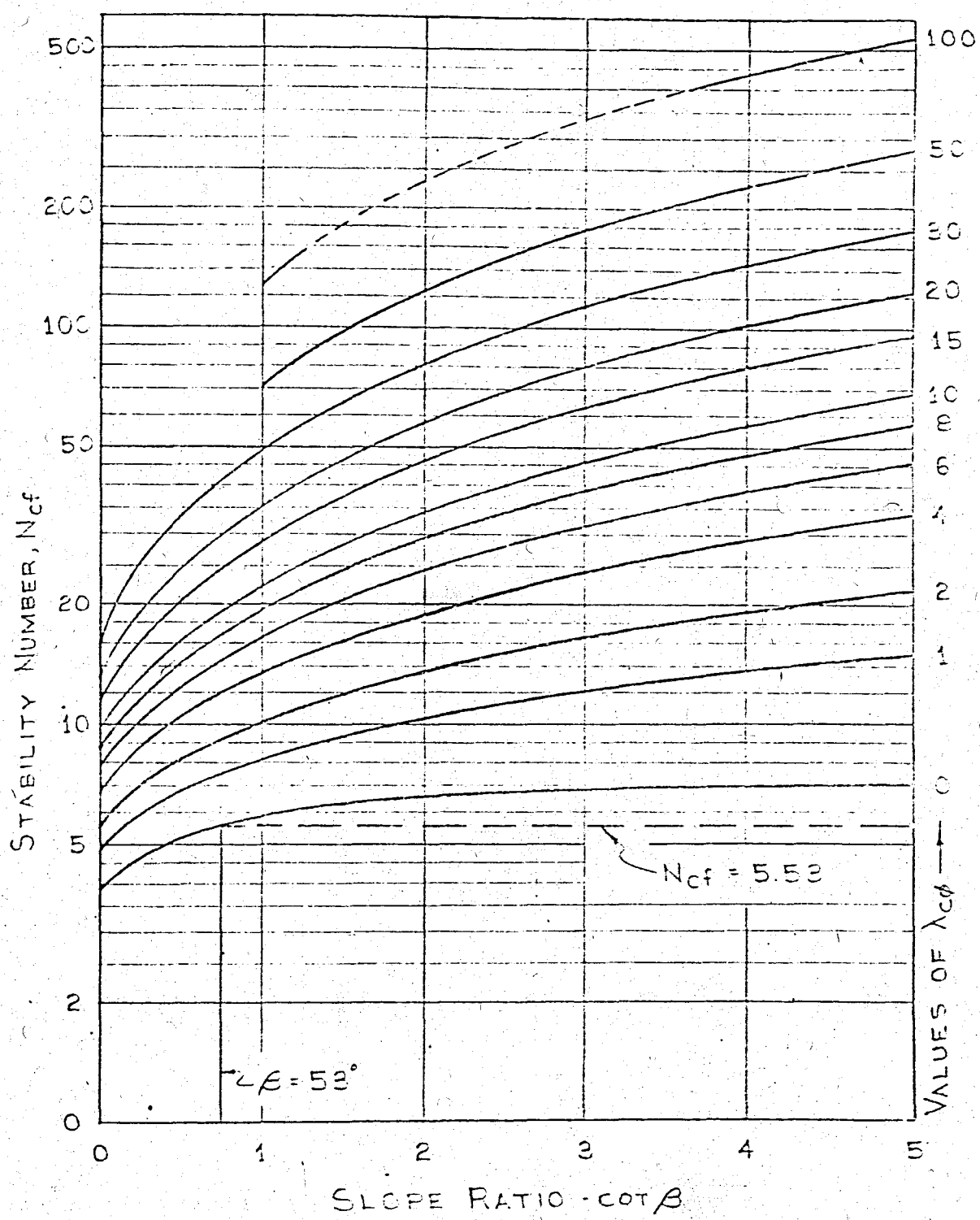

Fig. 2.14. Log spiral stability chart for toe circles. Total stress analysis. (After Wright, 1969)

Table 2.1. Stability numbers (Ncf) for most critical and toe log spirals (after Wright, 1969)

Slope: $\lambda_{c\phi}$	Vertical		1:1		2:1		3:1		4:1		5:1	
	Toe	Crit.	Toe	Crit.	Toe	Crit.	Toe	Crit.	Toe	Crit.	Toe	Crit.
1	4.74	4.74	8.1	8.1	10.3	10.2	12.0	11.9	13.6	13.4	15.0	14.8
2	5.50	5.50	10.0	10.0	13.4	13.4	16.3	16.3	19.1	18.9	21.7	21.5
4	6.77	6.77	13.3	13.3	18.9	19.0	24.1	24.1	29.1	29.1	33.0	33.9
6	7.83	7.83	16.3	16.3	24.2	24.2	31.5	31.5	38.6	38.6	45.6	45.5
8	8.76	8.76	19.2	19.2	29.1	29.2	38.6	38.7	47.9	47.9	56.9	56.9
10	9.61	9.61	22.0	22.0	34.0	34.1	45.6	45.6	56.9	56.9	68.0	68.0
15	11.45	11.45	28.6	28.6	45.8	45.8	62.6	62.6	79.1	79.1	95.4	95.4
20	13.03	13.03	34.9	34.9	57.2	57.2	79.2	79.2	101	101	122.3	122
30	15.72	15.72	47.0	47.0	79.5	79.6	111.8	111.9	144	144	175.3	175
50	-	-	70.2	70.2	123.0	123.2	176	176	228	228	280	280
100	-	-	125.6	125.6	-	-	-	-	-	435	537	-

If $\lambda_{c\phi}$ is zero, $\phi = 0$, it can be theoretically shown that the critical shear surface for slopes flatter than 53° will extend infinitely deep and have a stability number of 5.53 as indicated by the dashed line in Fig. 2.14. But in practice, the critical shear surface can't extend infinitely deep by the presence of some probable harder layer, and thus the actual stability number will lie somewhere between the values for an infinitely deep surface and one passing through the toe. If the spirals can't extend below the toe elevation which is in contradiction with the assumption of Fig. 2.14 which states that toe spirals can extend as deeply as necessary, the stability numbers may be considerably higher as can be seen in Fig 2.15. For flat slopes having low values of $\lambda_{c\phi}$ the critical surfaces intersect the slope above the toe. For steeper slopes having higher values of $\lambda_{c\phi}$, the critical spirals pass through the toe of the slope; whence as a conclusion, the stability number values on a rigid base, given by the chart in Fig. 2.16. correspond to the ones by the chart given in Fig. 2.14. for critical toe circles.

2.5. STABILITY CHARTS FOR ANALYSIS WITH PORE PRESSURE

The Stability charts presented so far were obtained for total stress parameters. The pore pressure parameter, r_u , for effective stress analysis, is defined as:

$$r_u = \frac{u}{\gamma H} \quad (2.27)$$

where:

- H : depth corresponding to pore pressure
- u : pore pressure
- γ : total unit weight of soil.

The use of charts giving the stability number for non zero pore pressure case are evaluated below. For this purpose Janbu's approximate procedure, Bishop and Morgenstern's and

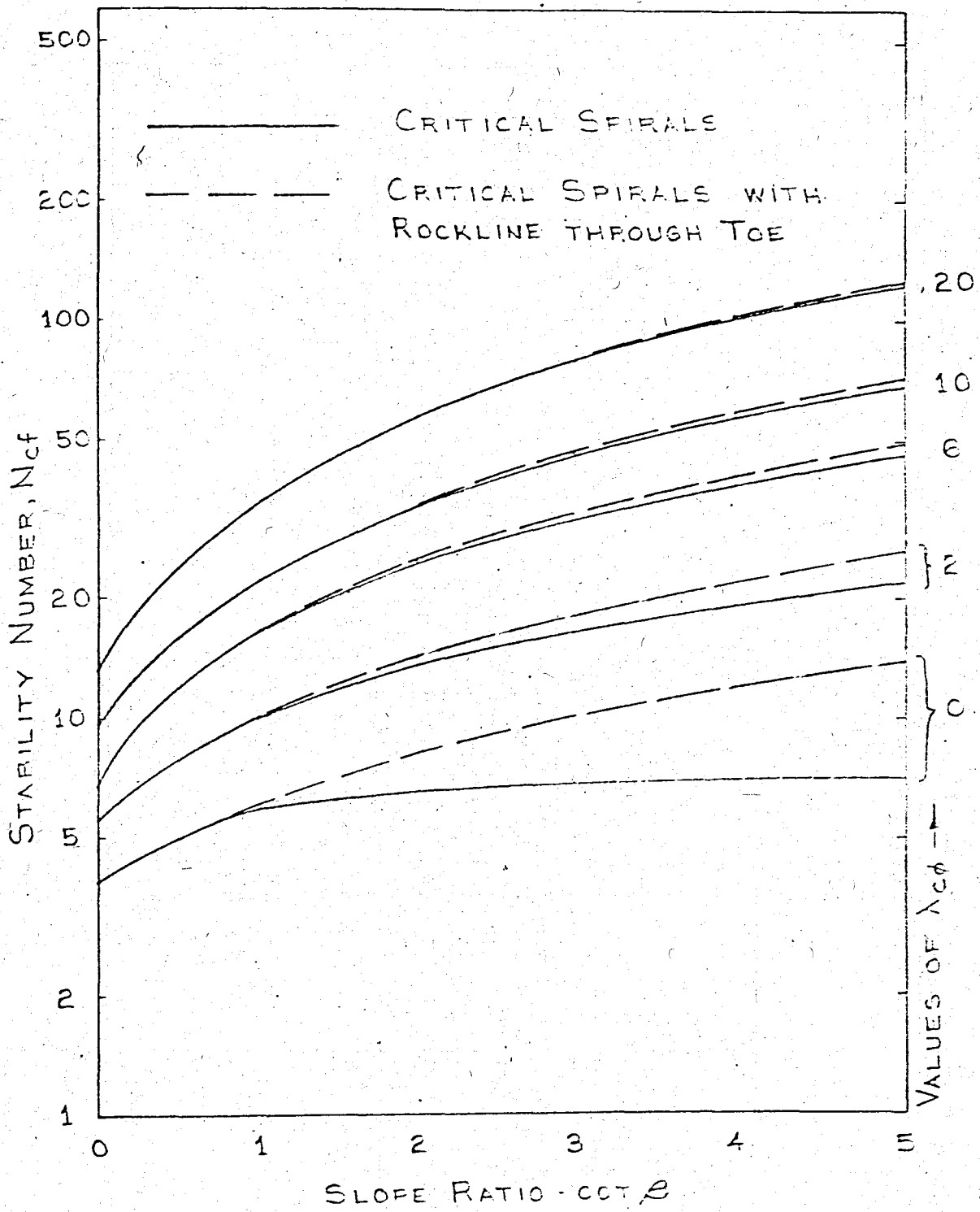

Fig.2.15. Comparison of log spiral stability numbers for toe and base spirals (after Wright, 1969)

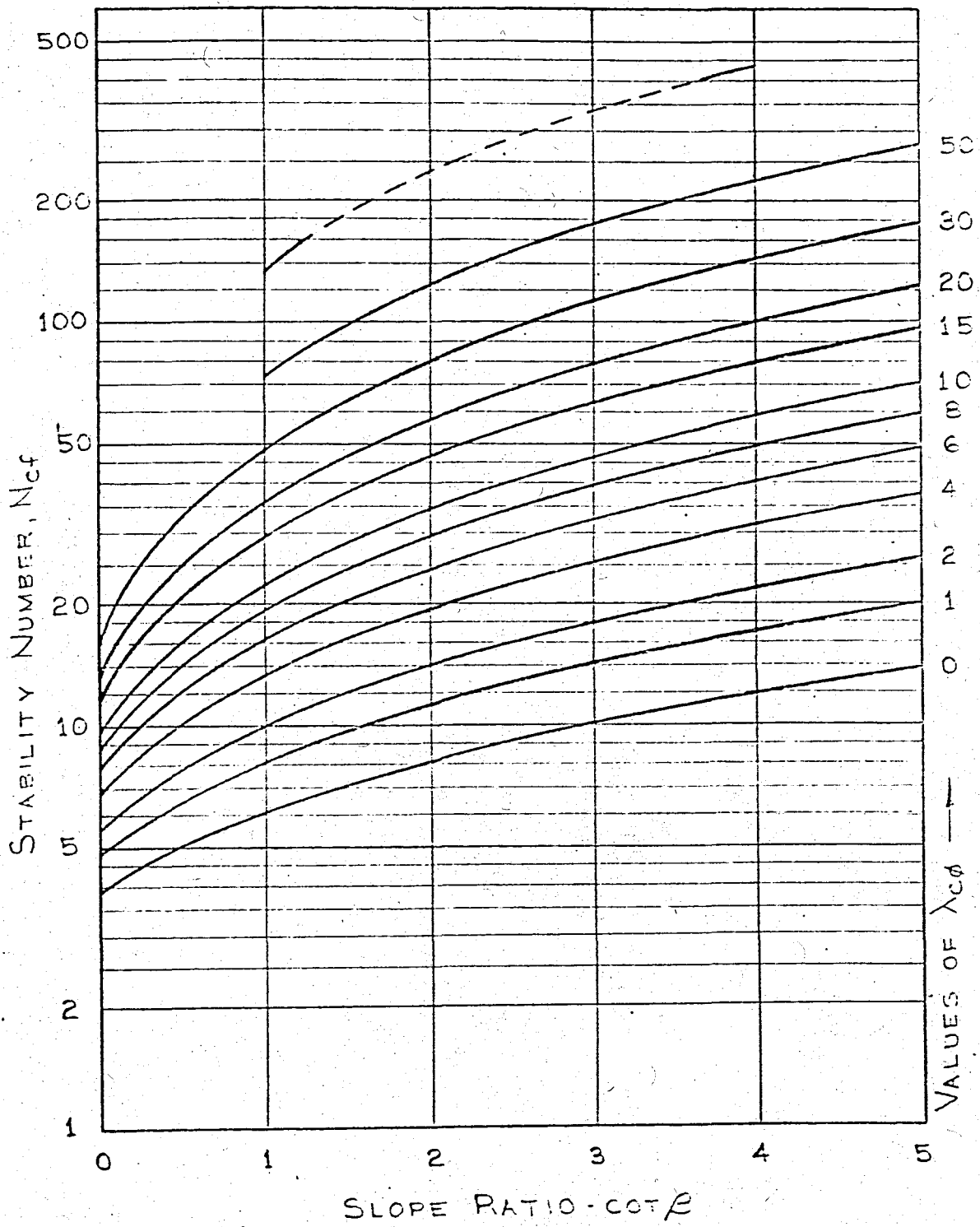

Fig.2.16. Log spiral stability chart for slopes on a rigid base, Total stress analysis.(after Wright, 1969)

Lowe and Karafiath's procedures are discussed.

A. Janbu's Approximate Procedure

Janbu (1967) has suggested an approximate procedure by which the charts in Fig. 2.13 may be used for analyses with pore pressures. By Janbu's procedure a modified parameter, $\lambda'_{c\phi}$ is calculated from the relationship,

$$\lambda'_{c\phi} = \lambda_{c\phi} (1 - r_u) \quad (2.28)$$

The value of $\lambda'_{c\phi}$ is then used to obtain the stability number from a chart for zero pore pressure, such as shown in Fig. 2.13. In determining the stability number from this chart, the value of $\lambda'_{c\phi}$ is used as if it were equivalent to $\lambda_{c\phi}$. Although Janbu (1967) has shown that for many slopes this procedure is acceptably accurate, a significant overestimate in the factor of safety may result from the use of this approach for some cases.

To investigate the magnitude of the overestimate in the factor of safety by Janbu's approach, stability numbers for various $\lambda'_{c\phi}$ values corresponding to $r_u = 0$ and $r_u = 0.6$ are calculated by Wright (1969) using Lowe and Karafiath procedure.

It is observed from Fig. 2.17 that the curves representing the stability numbers corresponding to a value of $r_u = 0.6$ lie considerably below the curves for no pore pressures. Similar relationships are also shown by Wright (1969) using Modified Bishop's and Spencer's (1967) procedures of analysis as shown in Fig. 2.18. As a summary according to Wright (1969) the values of factor of safety calculated using more accurate procedures are in some cases less than 80 % of the values calculated by Janbu's approximate approach as seen in Fig. 2.19.

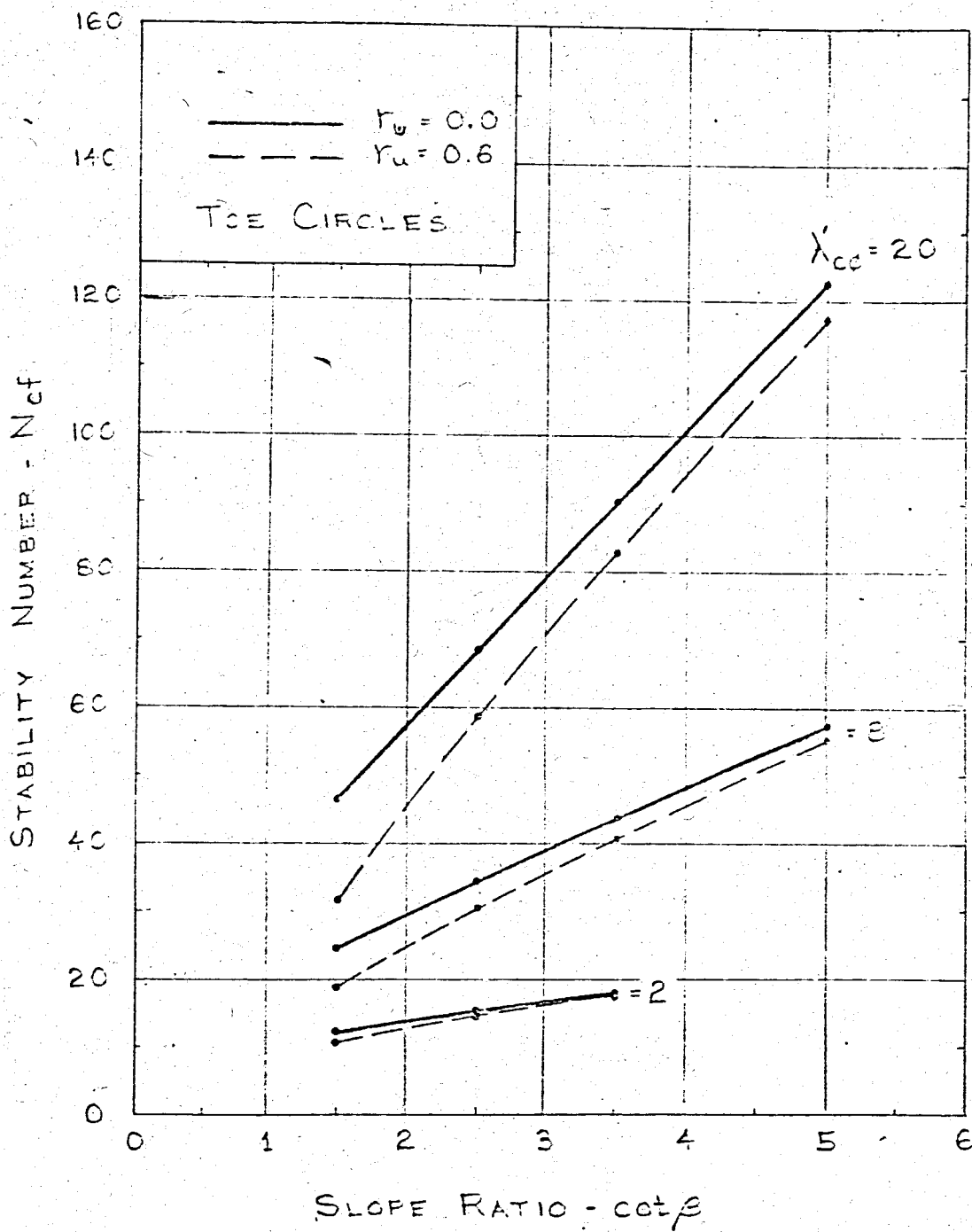

Fig.2.17. Stability numbers for $r_u = 0.0$ and 0.6 by Lowe and Karafiath's procedure (after Wright, 1969)

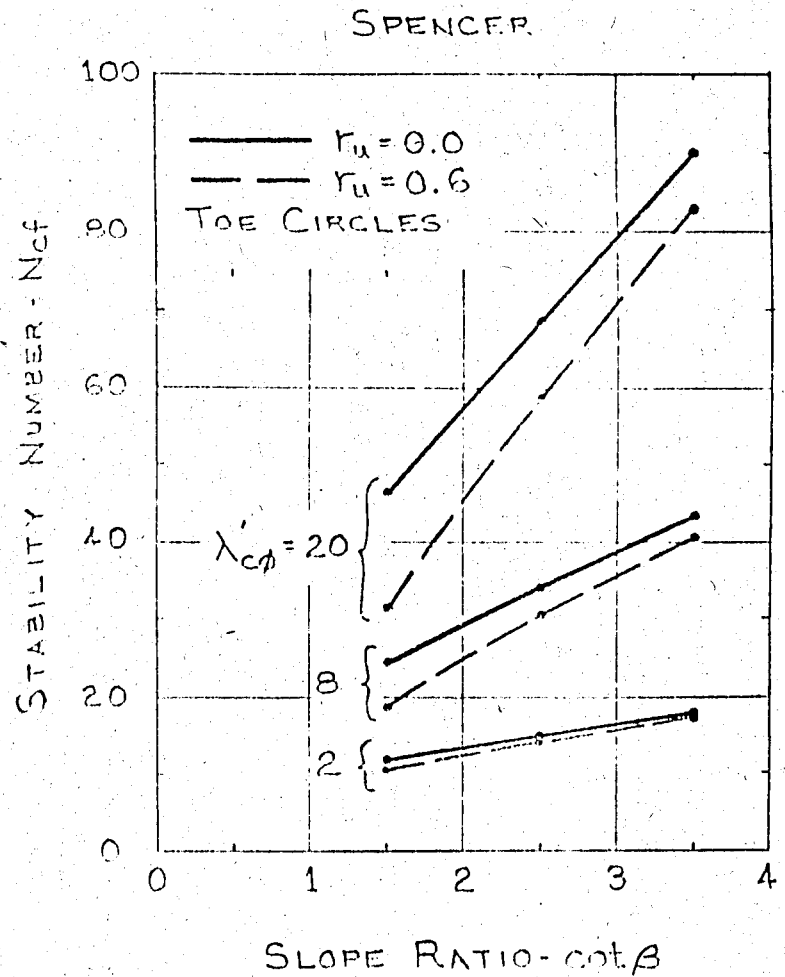
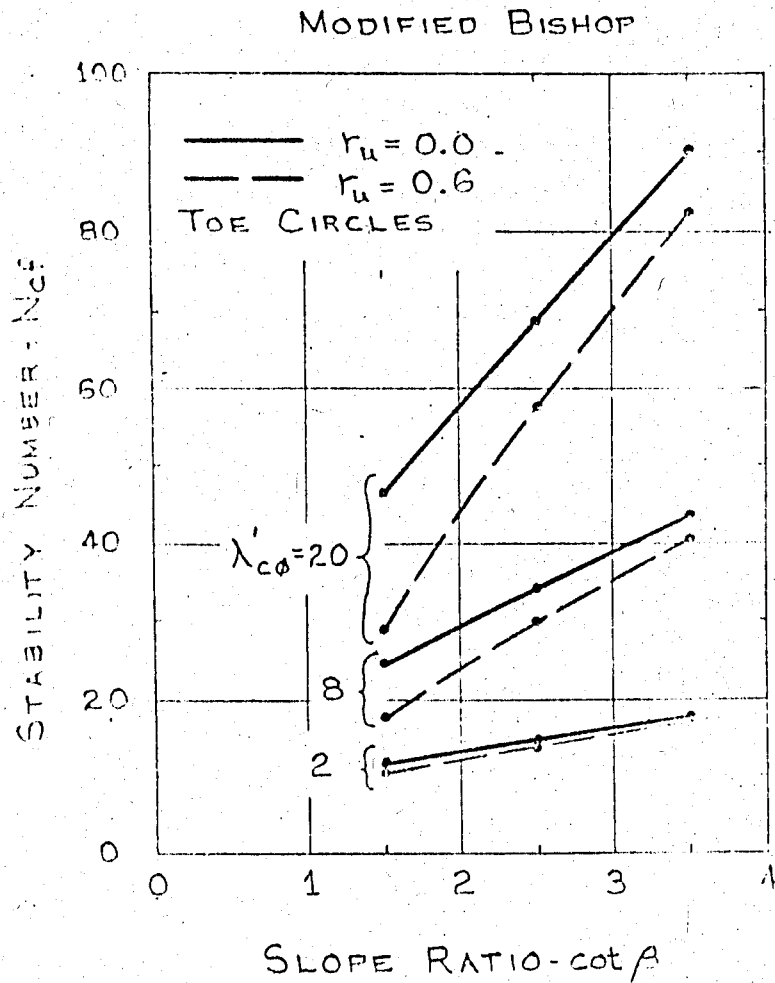
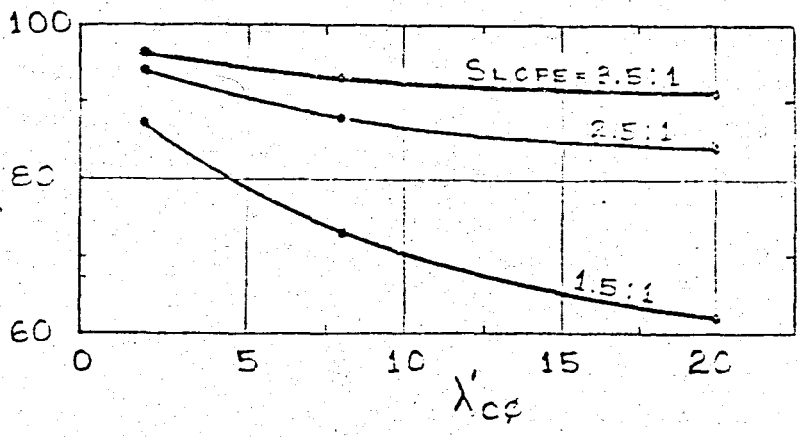

Fig. 2.18. Stability numbers for $r_u = 0.0$ and 0.6 by the Modified Bishop and Spencer's procedures (after Wright, 1969)

ACTUAL FACTOR OF SAFETY AS A PERCENTAGE OF THE VALUE CALCULATED BY THE SIMPLIFIED APPROACH OF JANBU

MODIFIED BISHOP



SPENCER

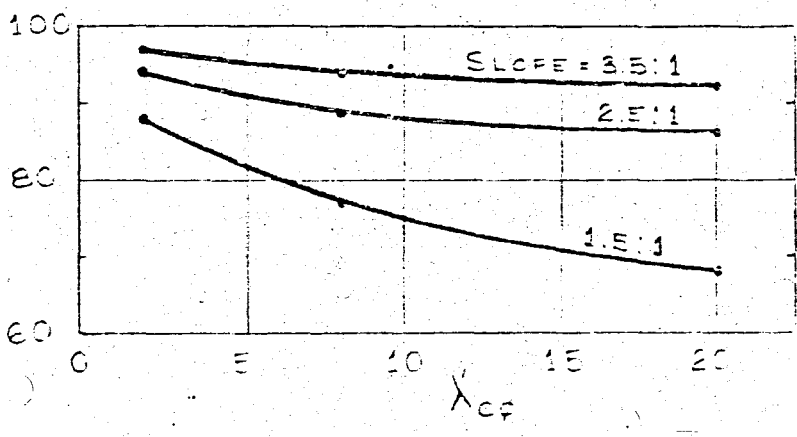

LOWE

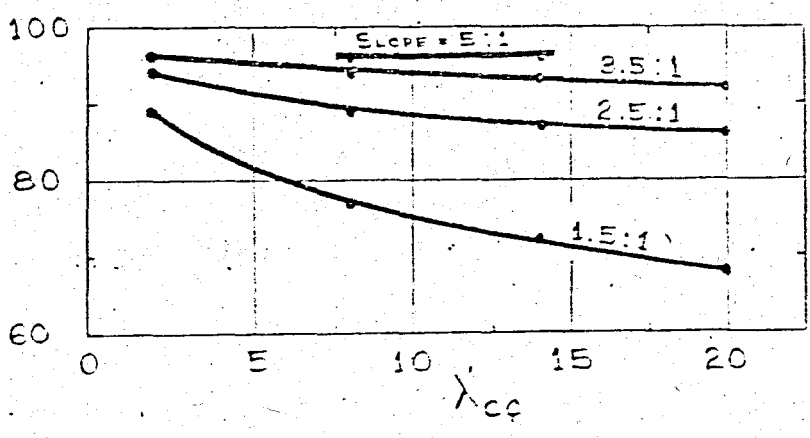

Fig.2.19. Comparison of the values of factor of safety calculated using Janbu's simplified approach with those calculated using more accurate procedures - $r_u = 0.6$ (after Wright, 1969)

Although the use of modified stability numbers will overestimate the factor of safety against the stability by any given procedure of analysis, if the technique is employed with the Ordinary Method of Slices, then the overestimates may tend to compensate, in part, for the errors associated with the Ordinary Method of Slices procedure.

B. Bishop and Morgenstern's Procedure

Bishop and Morgenstern (1960) have shown that the presentation of stability charts for analyses with pore pressures is considerably simplified by the observed linear relationship between the factor of safety and the value of pore pressure coefficient r_u as shown in Fig. 2.20.

The stability charts presented by Bishop and Morgenstern require the determination of the two dimensionless parameters, "m" and "n" from which the factor of safety is calculated using the relationship

$$F = m - nr_u \quad (2.29)$$

The dimensionless parameters are determined from the Fig. 2.21 through 2.23. when the $c'/\gamma H$, D and slope ratio values are known.

Where:

c' : cohesion intercept in terms of effective stress

γH : overburden pressure

D and slope ratio, are defined in Fig. 2.20.

When the charts in Fig. 2.21 through 2.23 are used, if the calculated r_{ue} value is found to be less than pore pressure parameter r_u , chart with a next D value higher than before is read again.

Similarly, Wright (1969) has demonstrated that the linearity in stability number exists in all procedures of

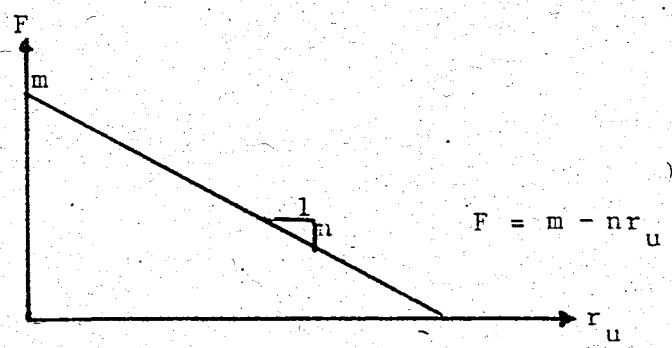
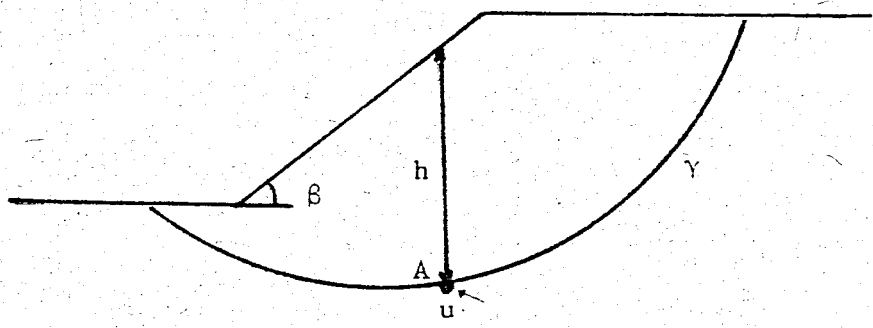

Fig. 2.20. Determination of dimensionless parameters m and n for Bishop and Morgenstern's procedure

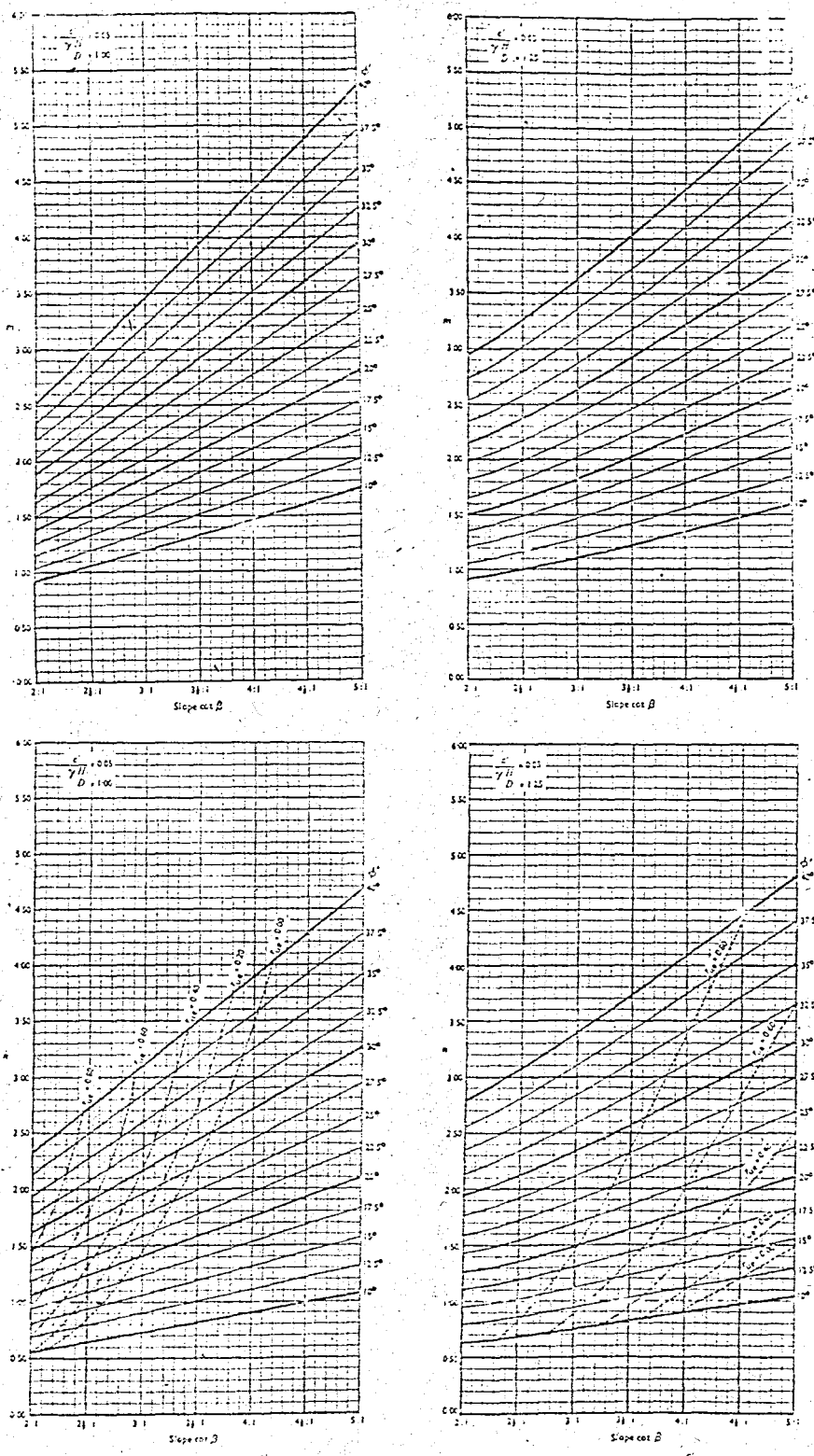

Fig. 2.21. Stability chart for analysis with pore pressure (after Bishop and Morgenstern, 1960)

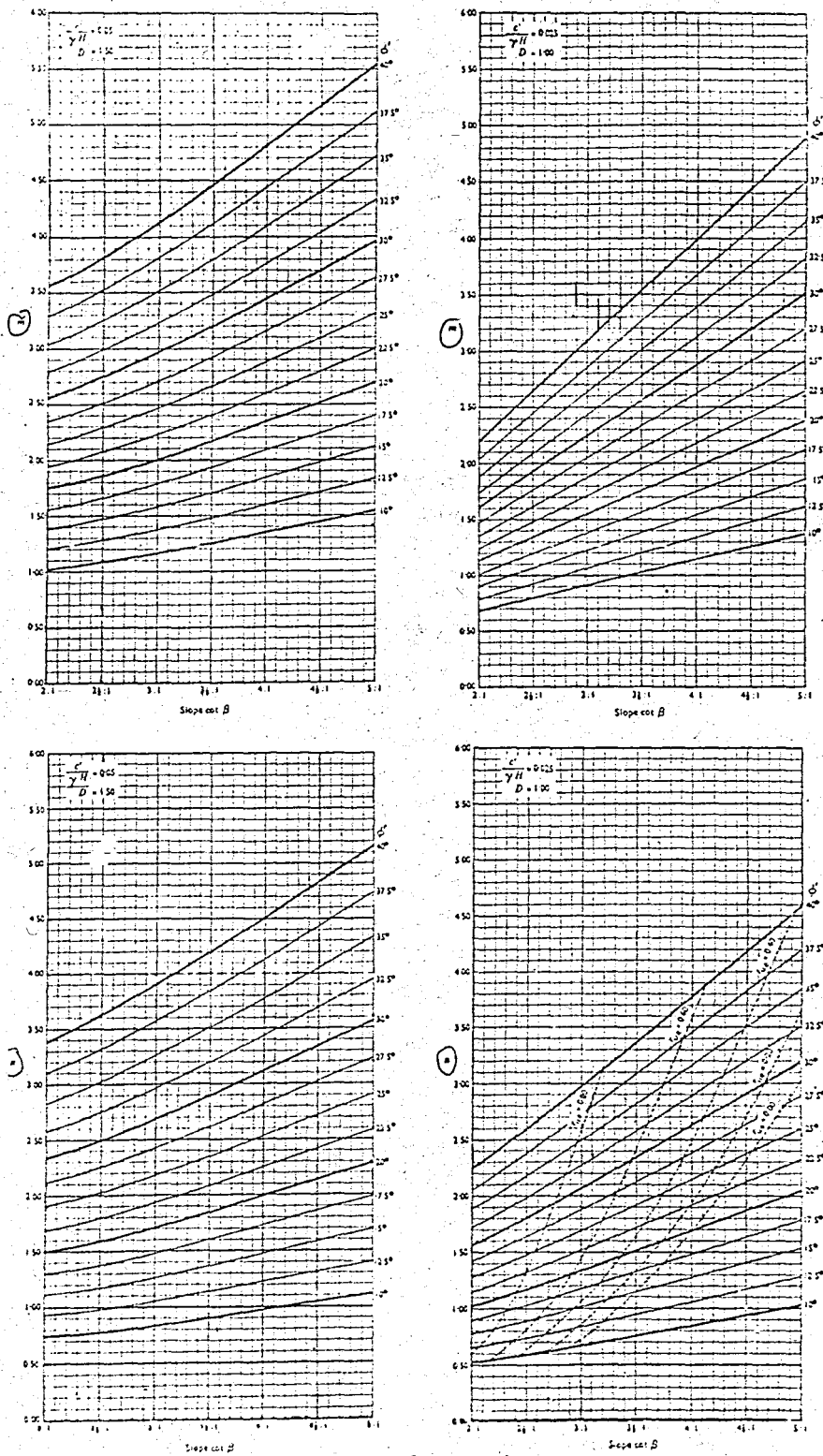

Fig. 2.22. Stability chart for analysis with pore pressure (after Bishop and Morgenstern, 1960)

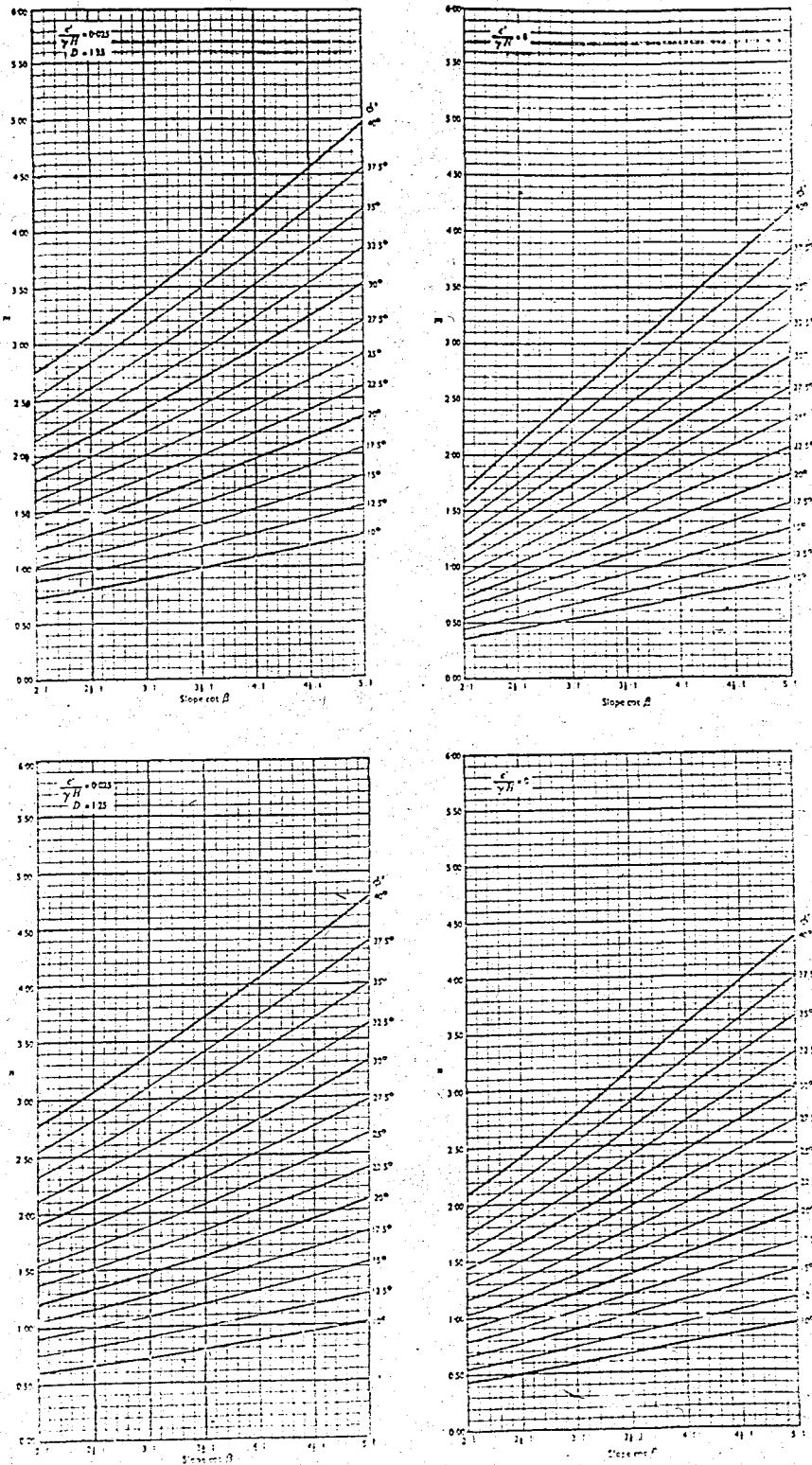

Fig. 2.23. Stability chart for analysis with pore pressure (after Bishop and Morgenstern, 1960)

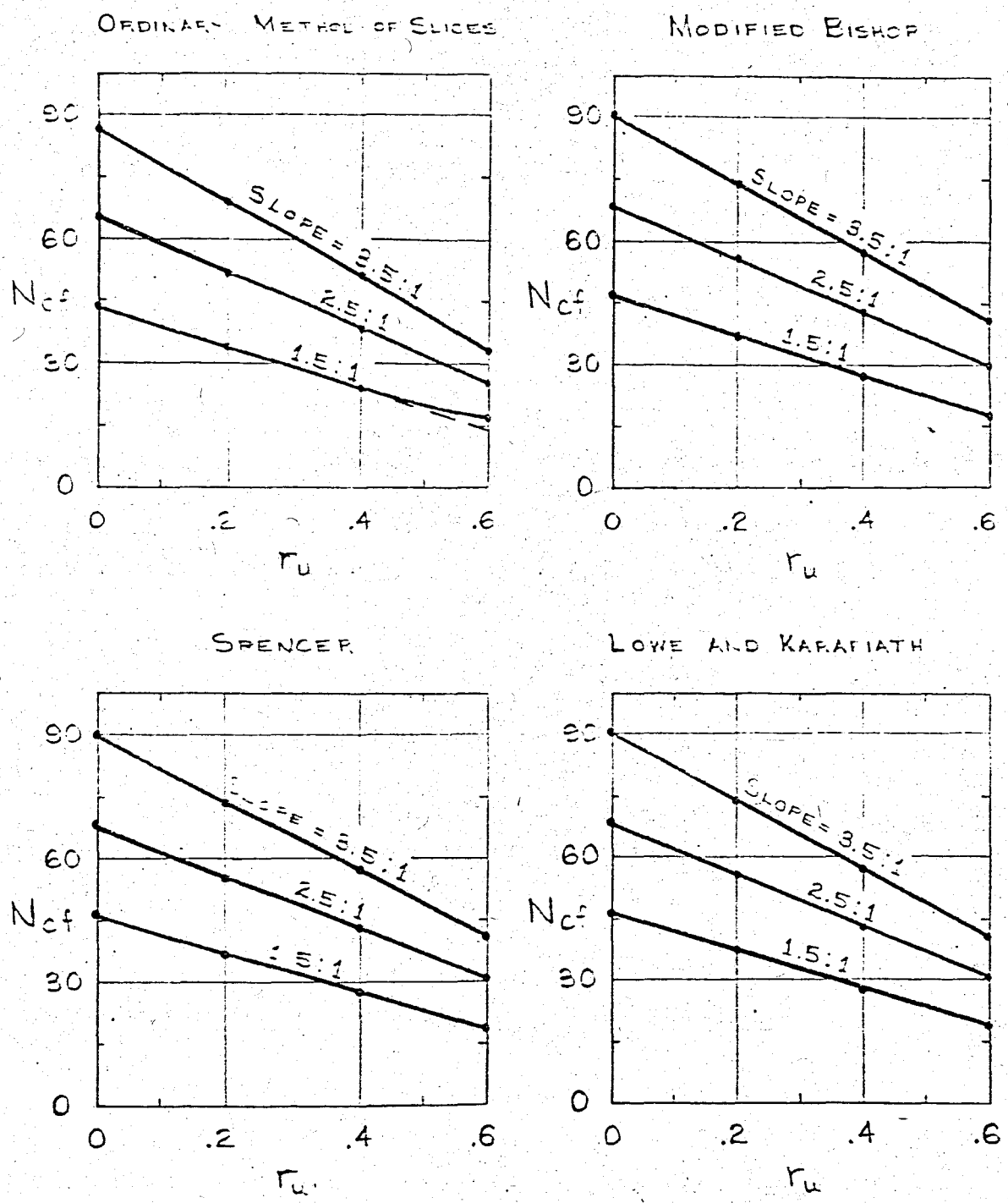

Fig.2.24. Relationships between the stability numbers (N_{cf}) and r_u for several procedures of analysis. $\lambda c \phi = 20$ (after Wright, 1969).

slope analysis, as shown in Fig 2.24. The only exception to linearity occurs for high values of r_u and steep slopes analyzed by the Ordinary Method of Slices procedure. The deviation from a straight line is the result of setting negative normal stresses equal to zero during the procedure.

C. Lowe and Karafiath's Procedure

By making use of the linearity between the factor of safety and the pore pressure coefficient (r_u) by Lowe and Karafiath's (1960) procedure, Wright (1969) has developed a chart for effective stress analyses, which is illustrated in Fig. 2.25. The following steps are utilized in the procedure:

1. For a given slope ratio and $\lambda_{c\phi}$ value one can enter to the chart from left and right to calculate the stability number corresponding to values of $r_u = 0.0$ and $r_u = 1.0$.

2. A straight line is drawn on the center portion of the chart connecting the values of the stability numbers corresponding to pore pressure values of zero and one.

3. The stability number (N_{cf}) corresponding to the desired r_u value is the ordinate of the intersection of the straight line with the line $y = r_u$.

An example illustrated on the chart finds $N_{cf} = 43$ for a given slope ratio of 2.5:1, $\lambda_{c\phi} = 20$ and $r_u = 0.4$.

Such a chart is useful to calculate the factor of safety easily but it is rather preferable to be used with other charts giving the location of the center of the critical circles for the reason of checking the assumptions in the analyses, because the chart is developed using a procedure to analyse the critical toe circles.

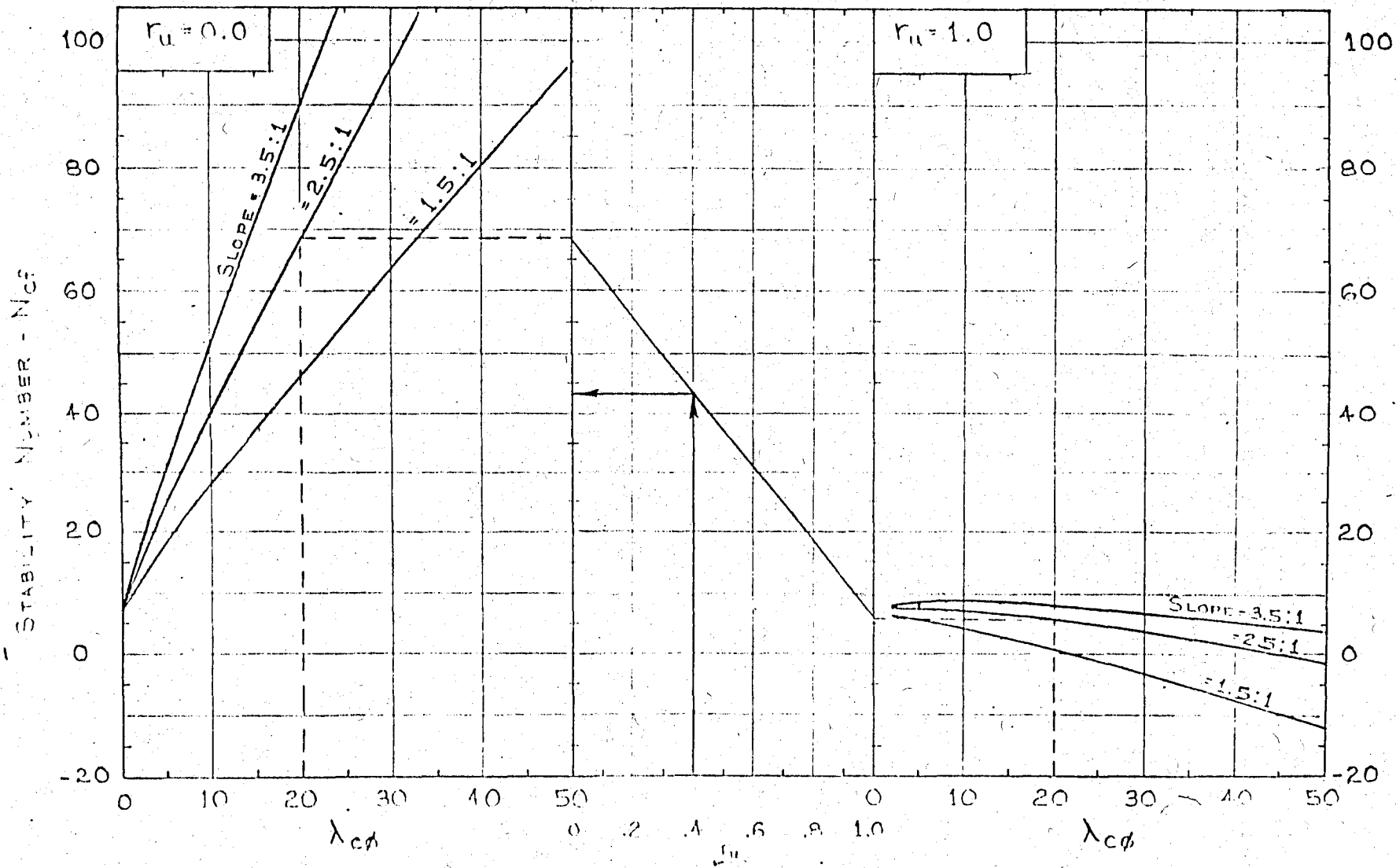

Fig.2.25. Stability chart for effective stress analysis Lowe and Karafiath's procedure (after Wright, 1969)

2.6. SLOPES IN COHESIONLESS MATERIALS (c=0 soils)

Slopes in cohesionless materials, where the critical failure mechanism is shallow sliding or surface raveling and slopes in residual soils, where a relatively thin layer of soil overlies soil or rock, the critical failure mechanism of which sliding along a plane parallel to the slope, at the top of the firm layer can be analysed accurately using the charts given by Duncan and Buchignan (1975) which are based on infinite slope analyses.

Analysis can be done by using the effective stress parameters or by total stress parameters.

A. Effective Stress Analysis

Steps for use of the chart for effective stress analysis could be given as follows:

1- The pore pressure ratio, r_u could be determined from:

$$r_u = \frac{u}{\gamma H} \quad (2.27)$$

where

u = pore pressure

γ = total unit weight

H = depth corresponding to pore pressure u .

For special seepage conditions pore pressure ratio, r_u , could be calculated:

a) For seepage parallel to slope it is given by:

$$r_u = \frac{X}{T} \frac{\gamma_w}{\gamma} \cos^2 \beta \quad (2.30)$$

b) For seepage emerging from slope it is given by:

$$r_u = \frac{\gamma_w}{\gamma} \frac{1}{1 + \tan\beta \tan\theta} \quad (2.31)$$

Referring to Fig. 2.26:

β : Slope angle

θ : Angle between the direction of seepage and horizontal

X: distance from the depth of sliding to the surface of seepage, measured normal to the surface of the slope

T: distance from the depth of sliding to the surface of the slope, measured normal to the surface of the slope and the other factors are as defined previously.

2- The values of the dimensionless parameters A and B could be determined from the charts provided in Fig. 2.26.

3- The factor of safety F is given by:

$$F = A \frac{\tan\phi'}{\tan\beta} + B \frac{c'}{\gamma H} \quad (2.32)$$

Where

ϕ' = angle of internal friction in terms of effective stress

c' = cohesion intercept in terms of effective stress

H = depth of sliding mass measured vertically

B. Total Stress Analysis

Steps for use of charts for total stress analyses could be summarized as follows:

1- The value of parameter B, could be determined From Fig.2.26.

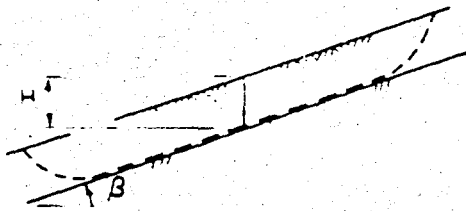

γ = total unit weight of soil
 γ_w = unit weight of water
 c' = cohesion intercept
 ϕ' = friction angle } Effective Stress
 r_u = pore pressure ratio = $\frac{u}{\gamma H}$
 u = pore pressure at depth H

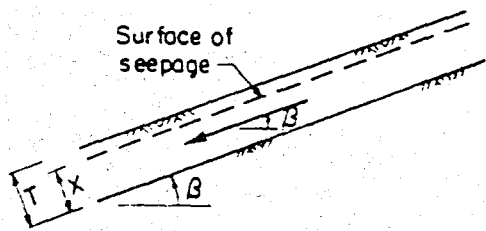

Seepage parallel to slope
 $r_u = \frac{x}{T} \frac{\gamma_w}{\gamma} \cos^2 \beta$

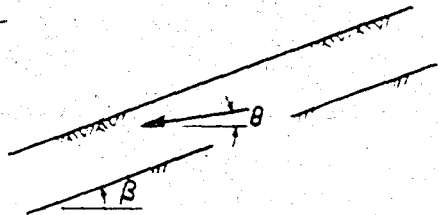

Seepage emerging from slope
 $r_u = \frac{\gamma_w}{\gamma} \frac{1}{1 + \tan \beta \tan \theta}$

Steps:

- ① Determine r_u from measured pore pressures or formulas at right
- ② Determine A and B from charts below
- ③ Calculate $F = A \frac{\tan \phi'}{\tan \beta} + B \frac{c'}{\gamma H}$

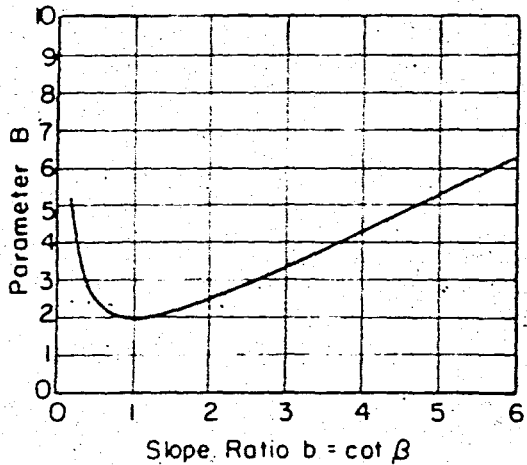
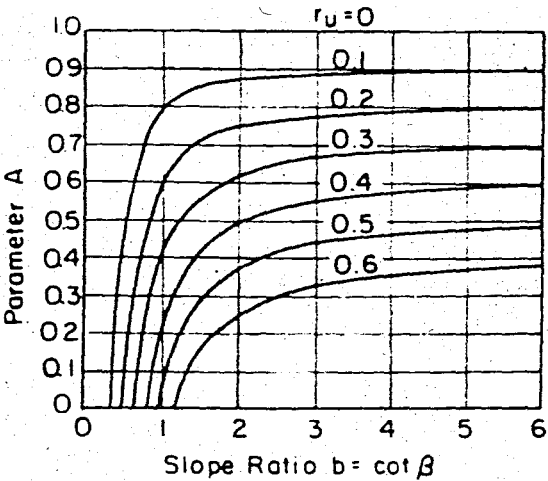

Fig.2.26. Stability charts for infinite slopes. (after Duncan and Buchignani, 1975).

2- The factor of safety is then calculated using:

$$F = \frac{\tan\phi}{\tan\beta} + B \frac{c}{\gamma H} \quad (2.33)$$

Where :

ϕ = angle of internal friction in terms of total stress

c = cohesion intercept in terms of total stress, and other factors are as defined previously.

3. THE MECHANICS AND EQUILIBRIUM METHODS OF DETAILED STABILITY ANALYSIS

3.1. INTRODUCTION

The procedures of analysis which have been previously described in Chapter 2 are similar in that they consider only the equilibrium of soil mass bounded by the shear and slope surfaces. In contrast to these procedures, many other techniques of analysis have been developed in which the soil mass is divided vertically into a number of slices and are known as procedures of slices. The solutions of these procedures require some assumptions, detailed hand calculations or use of computer, but they have the advantage to solve the slope stability problem for all types of soils and complicated soil profiles.

In this chapter the procedures of slices namely the procedures of slices satisfying the moment equilibrium (Ordinary Method of slices, Bishop's Procedure, Bishop's Modified procedure, Spencer's procedure, Morgenstern and

Price's procedure) and the procedures of slices satisfying the force equilibrium (Lowe and Karafiath's procedure, Corps of Engineers' Weage Analysis, Janbu's Generalized procedure of Slices and Janbu's Simplified procedure) are discussed, and some of the procedures stayed above are used in the analyses of the previous and the forthcoming chapters.

3.2. PROCEDURES OF SLICES SATISFYING MOMENT EQUILIBRIUM

The procedures of analysis described on Chapter 2 are similar in that they consider only the equilibrium of soil mass bounded by the shear and slope surfaces. In contrast to these procedures, many other techniques of analysis have been developed in which the soil mass is divided into a number of slices, as shown in Fig. 3.1. Each of these slices is acted on by the forces shown in Fig. 3.2 and consequently if the slice is assumed to be in complete equilibrium, these forces must satisfy the three conditions of equilibrium for each slice. The system of equations and unknowns associated with complete equilibrium of the entire soil mass in terms of "n" slices is summarized in Table 3.1.

From Table 3.1 it may be noted that there are $5n-2$ unknowns which must be determined in order to satisfy equilibrium for the n slices. However, because there are only $3n$ equations of slice equilibrium the equations and unknowns in Table 3.1 are indeterminant except when only one slices is used. Consequently, the use of slices does not eliminate the statical indeterminacy of the soil mass which has been previously described with regard to procedures without slices.

A. Moment Equilibrium of a Circular Shear Surface

The unknown normal force locations on the base of each slice may be conveniently eliminated from the equation of

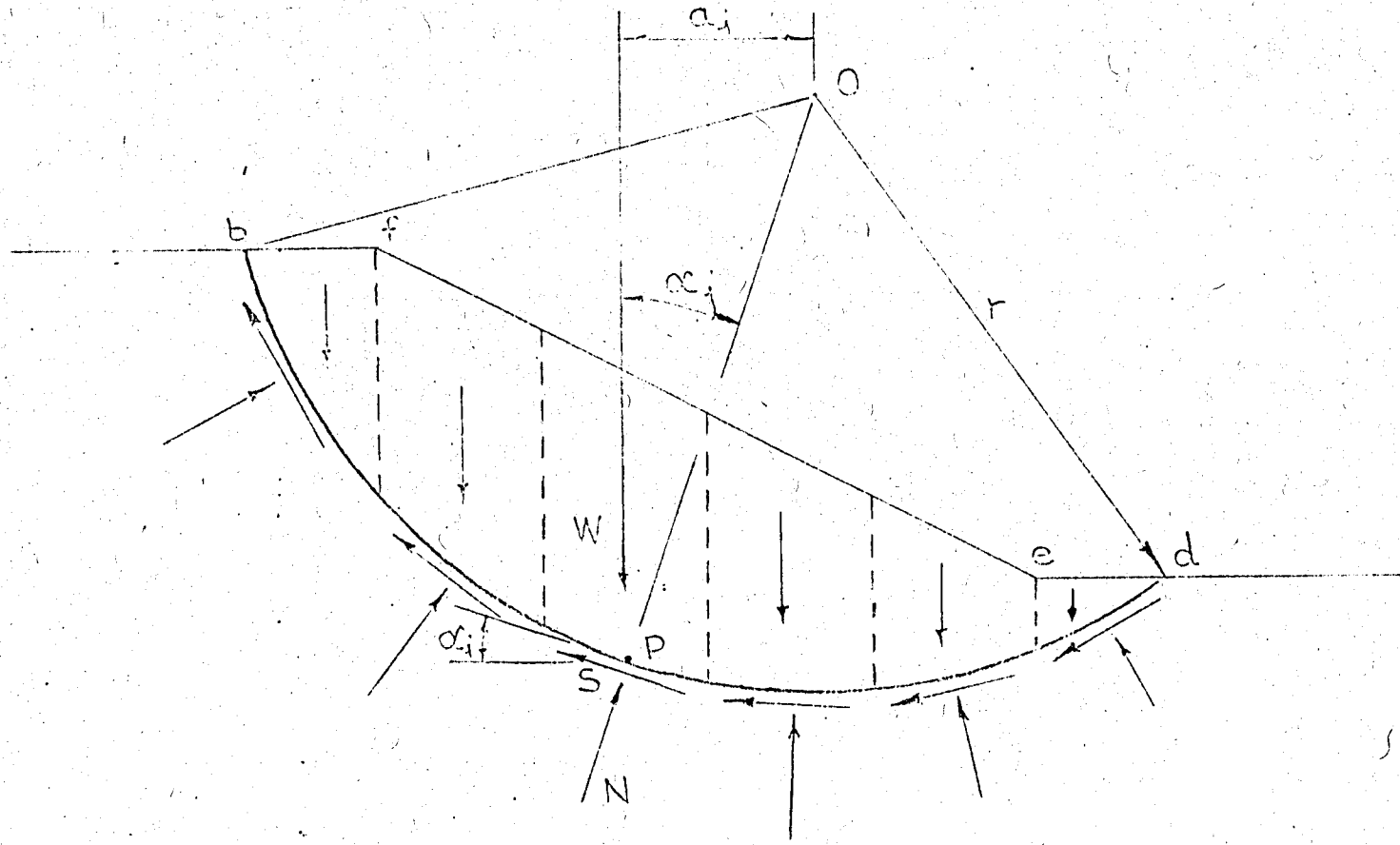

Fig.3.1. Imaginary slice representation for a circular shear surface

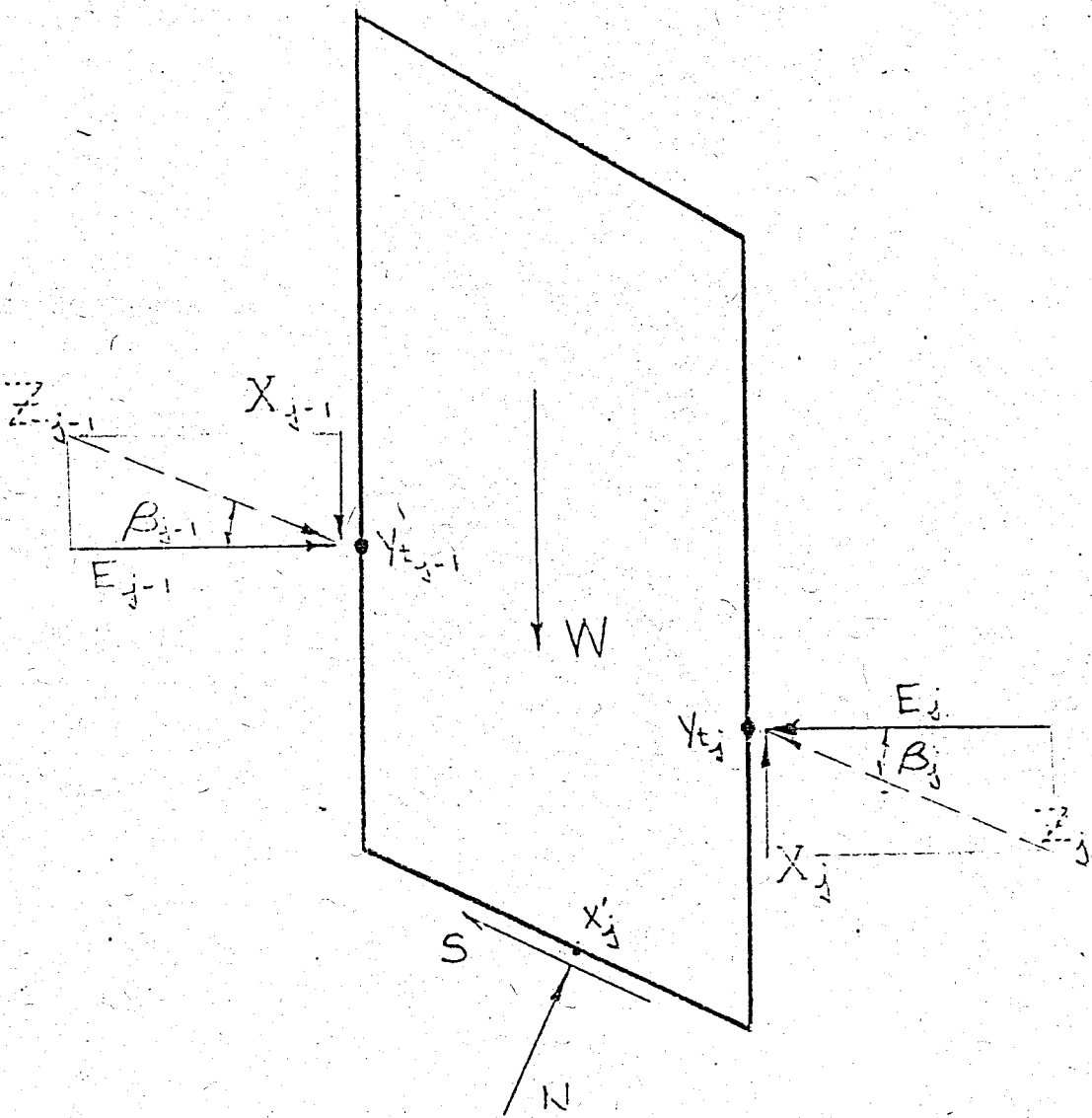

Fig.3.2. Forces acting on a typical slice

overall moment equilibrium by considering a circular shear surface. For such a surface the equation of overall moment equilibrium may be written as:

$$\sum_1^n W r \sin \alpha - \sum_1^n S \Delta l r = 0 \quad (3.1)$$

Where:

- W: Weight of an individual slice
- r: radius of the circle
- α : base slope of the slice
- s: shear strength
- Δl : length of the base of a particular slice

Knowing that

$$s = c' + (\sigma - u) \tan \phi' \quad (3.2)$$

Where

- σ : normal stress that act on the soil mass
- u: pore pressure on the failure surface
- c' and ϕ' are corresponding effective shear strength parameters.

By substituting the expression for s given by Eq(3.2) into Eq(3.1), the factor of safety may be expressed as,

$$F = \frac{\sum_1^n c' \Delta l + (N - u \Delta l) \tan \phi'}{\sum_1^n W \sin \alpha} \quad (3.3)$$

Where

- N: Normal force acting on the base of the slice, and
- c' , ϕ' , N, W and α correspond to the same slice.

TABLE 3.1

Equations and Unknowns Associated With Complete Slice Equilibrium

Equations

n	Moment equilibrium equations for each slice
n	Vertical force equilibrium equations for each slice
n	Horizontal force equilibrium equations for each slice
<u>3n</u>	Total Equations

Unknowns

1	Factor of safety
n	Normal forces on the base of each slice, N_j
n	Locations of the normal forces on the base of each slice
n-1	Interslice normal forces(E) n-1 Resultant interslice forces(Z)
	or
n-1	Interslice shear forces(X) n-1 Inclinations of resultant interslice forces(β)
<u>n-1</u>	Locations of interslice forces (y_t)-(line of thrust)
<u>5n-2</u>	Total unknowns

In formulating this expression for the factor of safety it was assumed that the normal forces, N , and the weight forces, W , acted through a point at the center of the base of each slice. This assumption reduces the number of unknowns in Table 3.1 to $4n-2$, the remaining unknowns are still statically indeterminate from the $3n$ equilibrium conditions; thus, the factor of safety cannot be calculated from Eq. 3.3 without further assumptions.

B. The Ordinary Method of Slices

The most commonly employed assumptions in the procedures of slices are associated with the interslice forces. The simplest assumption that can be made with regard to these force is that they are zero. By making such an assumption the normal forces shown in Fig. 3.3 may be determined by resolving forces normal to the base of each slice; thus

$$N = W \cos \alpha \quad (3.4)$$

However, by making such an assumption the last $3n-3$ unknowns in Table 3.1 are eliminated, and consequently the system of equations and unknowns is highly overdetermined. As a result, the above equation for normal forces, N , does not necessarily satisfy equilibrium in any consistent direction except for the case of a plane shear surface; nevertheless, this expression does provide a convenient means of calculating the normal forces necessary to evaluate the factor of safety.

By substituting the expression for N given by Eq. 3.4 into Eq. 3.3 the following expression for the factor of safety may be written

$$F = \frac{\sum_1^n c \Delta l + (W \cos \alpha - u \Delta l) \tan \phi}{\sum_1^n W \sin \alpha} \quad (3.5)$$

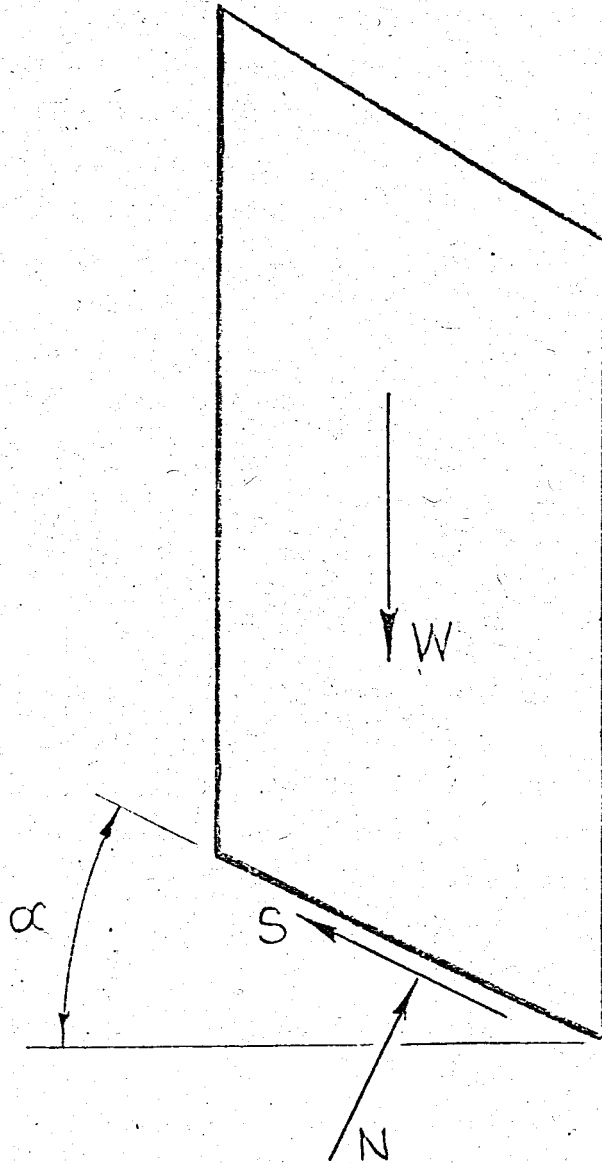

Fig.3.3. Forces acting on a typical slice with no side forces

This equation is the well-known expression for the factor of safety of a circular shear surface by the Ordinary Method of Slices.

The assumption resulting in the expression used for the normal force, N , was first proposed by Fellenius in 1927, and thus the Ordinary Method of Slices is sometimes referred to as Fellenius' Method. This procedure provides a direct means of calculating the factor of safety from the equation of overall moment equilibrium; however, neither force nor moment equilibrium is satisfied for the individual slices. Regardless of the inaccuracies in the Ordinary Method of Slices, this procedure offers several distinct advantages over the methods which have been discussed in chapter two. The Ordinary Method of Slices is the only procedure that may be used to analyze inhomogeneous soil profiles with non-uniform values of ϕ . Furthermore the factor of safety for a selected shear surface may be computed directly without necessity for the trial and error solutions required by the Friction Circle and logarithmic Spiral procedures.

C. The Role of Side Forces

One of the most important advantages of the procedures of slices is the opportunity which these procedures provide for judging the reasonableness of a solution from the side forces. If the distribution of the side forces and their location represent a reasonable distribution of stresses within the soil mass, then the resulting distribution of stresses along the shear surface is usually reasonable also. In contrast to this approach, procedures, such as Bell's (1968), which consider only the stresses along the shear surfaces, require that the reasonableness of the solution be judged directly from the normal stress distribution.

In the procedures of slices it has been shown that the neglect of the influence of side forces leads to an unreason-

able normal stress distribution, and thus, to an incorrect value for the factor of safety. However, in order to more correctly determine the influence of side forces it is necessary to satisfy the $3n$ conditions of slice equilibrium more completely than was done in the Ordinary Method of Slices procedure.

D. Early Graphical Procedures

A number of graphical solutions such as Petterson's procedure (1955), Fellenius' Graphical procedure (1936), Raedschelder's procedure (1948) have been presented which satisfy all conditions of equilibrium. Although there are some differences among these procedures with regard to the assumptions made to achieve statical determinacy, they all fully satisfy the $2n$ conditions of force equilibrium by the closure of the force polygon for each slice, and the n conditions of moment equilibrium are satisfied by line polygons. While any of these procedures might give an acceptable solution for the factor of safety, the relative complexity of obtaining a complete solution by graphical trial and error has limited their use.

E. Numerical Formulation of Slice Equilibrium

A number of numerical procedures of stability analyses, which are very similar to the graphical techniques, have been developed. Because of their increased simplicity and adaptability to computer solution, these numerical procedures have gained a wider acceptance than the graphical techniques. For the purpose of examining these various numerical solutions it is convenient to consider the three equation of equilibrium for an individual slice such as shown in Fig. 3.4.

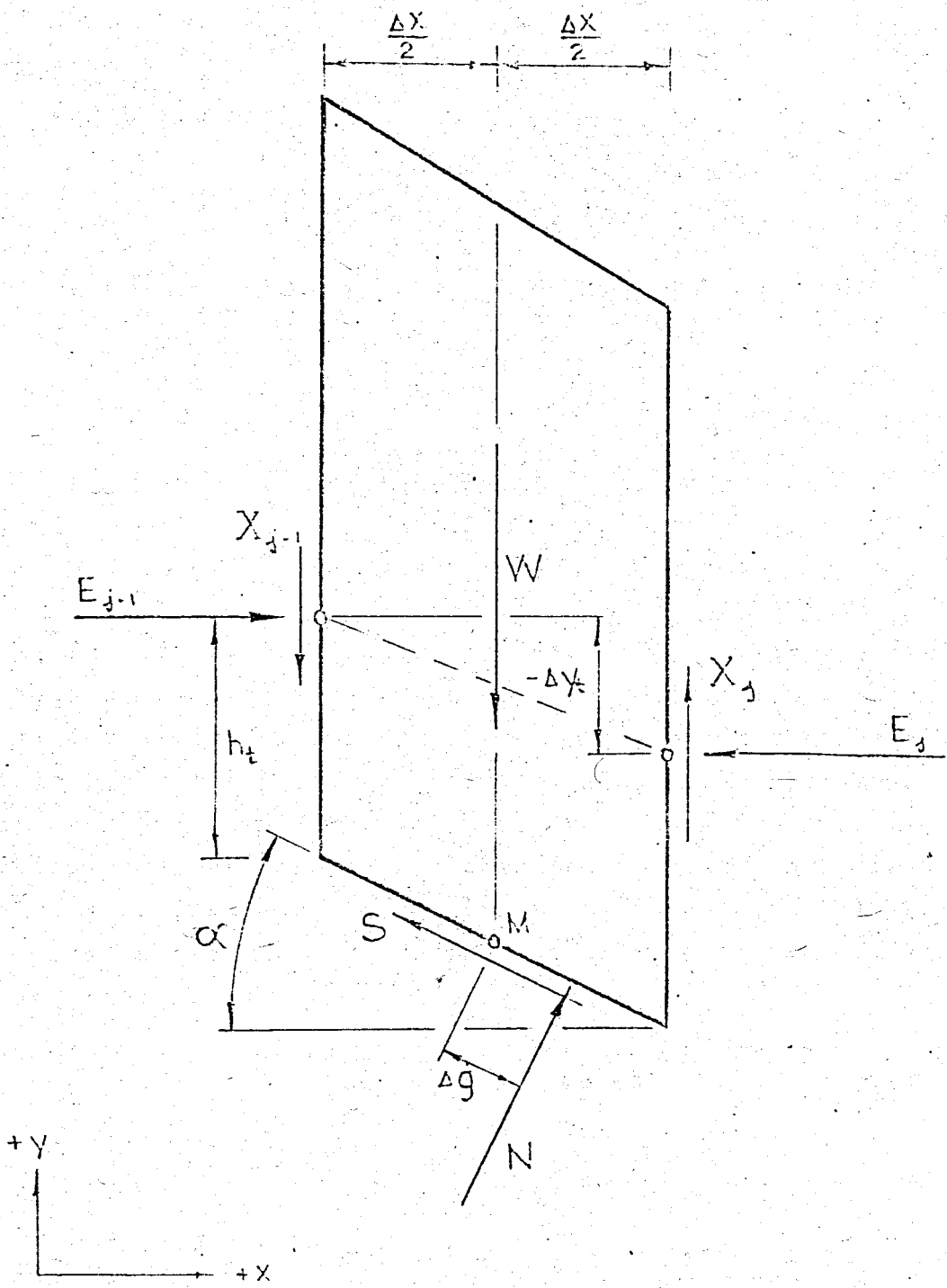

Fig. 3.4. Forces and locations involved in the equilibrium of an individual slice.

equations as well as the moment equilibrium equation for every slice is a necessary and sufficient condition for complete equilibrium. In the absence of any external loads on the slope the boundary conditions which the solution to these three sets of equations must satisfy may be expressed as:

$$\Sigma(X_j - X_{j-1}) = 0 \quad (3.11)$$

$$\Sigma(E_j - E_{j-1}) = 0 \quad (3.12)$$

$$\Sigma M_j = 0 \quad (3.13)$$

An alternate way of stating these same requirements is that the side forces and moments on the extreme ends of the shear surface are zero. In other words;

$$X_o = X_n = 0 \quad (3.14)$$

$$E_o = E_n = 0 \quad (3.15)$$

$$M_o = M_n = 0 \quad (3.16)$$

For this reason the unknown forces acting on the sides of the slices are not $n + 1$ corresponding to the total number of slices but rather are $n-1$ corresponding to the number of boundaries between slices.

All procedures of slices assume that S and N are related by the Mohr - Coulomb strength criterion and a constant factor of safety expressed as,

$$S = \frac{1}{F} [c' \Delta l + (N - u \Delta l) \tan \phi'] \quad (3.17)$$

By employing this expression for the shear force, s , on the base of each slice, this force is reduced from an independent unknown to a dependent quantity defined in terms of the unknowns F and N .

It is interesting to note the similarity between Eq. (3.9) and the expression for the normal forces which is employed in the Ordinary Method of Slices. Bishop (1955) has shown that these two expressions involving the normal forces are identical if the resultant of all side forces acts parallel to the base of each slice. Thus, the Ordinary Method of Slices assumption of no interslice forces is equivalent to assuming that their resultant is parallel to the base, however, the magnitude of this resultant cannot be calculated without additionally satisfying moment equilibrium.

F. Solution of Slice Equilibrium Equations

As explained previously, in order to achieve statical determinacy the $5n-2$ unknowns must be reduced to $3n$ by making $2n-2$ assumptions. The most commonly employed assumption is that the location of the normal forces on the base of each slice is known. This force is usually assumed to be located at the center of the base or the point at which the weight force intersects the base. However, even with this assumption, $n-2$ assumptions still must be made before statical determinacy is achieved. The nature of these additional assumptions varies from procedures to procedure and for this reason it is appropriate to consider the specific techniques for solution on an individual basis.

Bishop's Procedure

In 1955 Bishop presented a procedure for slope analysis which satisfies the $3n$ conditions of static equilibrium. Nonveiller (1965) has shown that Bishop's approach may also be applied to a surface of any shape.

Bishop assumed that the normal and weight forces act through a point on the center of the base of each slice, and thus, the moment equation for a circular surface is expressed as,

$$W_r \sin \alpha - \Sigma S_r = 0 \quad (3.18)$$

or,

$$\frac{\Sigma S}{\Sigma W \sin \alpha} = 0 \quad (3.19)$$

In addition, by combining the shear strength expression with Eq. (3.6) and eliminating the unknown force, the equation of vertical force equilibrium may be written as,

$$S = \frac{1}{F} \{c' \Delta x + [W - (X_j - X_{j-1}) - u \Delta x] \tan \phi\} k_\alpha \quad (3.20)$$

in which

$$k_\alpha = \frac{\sec \alpha}{1 + \frac{\tan \alpha \tan \phi}{F}} \quad (3.21)$$

By substituting this expression into the overall moment equation Eq. (3.19) the factor of safety may be expressed as:

$$F = \frac{\Sigma \{c' \Delta x + [W - (X_j - X_{j-1}) - u \Delta x] \tan \phi\} k_\alpha}{\Sigma W \sin \alpha} \quad (3.22)$$

The values of the interslice shear forces (X_j) in this equation must also satisfy the boundary condition:

$$\Sigma (X_j - X_{j-1}) = 0 \quad (3.11)$$

A solution to Eq. (3.22), however, is not necessarily a solution satisfying all conditions of equilibrium. In order to assure satisfaction of complete equilibrium it is necessary, in addition, to satisfy force equilibrium in a direction other than vertical. For this purpose Bishop chose to consider equilibrium in a direction parallel to the base of each slice which may be expressed from Eq. (3.10) as,

$$(E_j - E_{j-1}) = [W - (X_j - X_{j-1})] \tan\alpha - S \sec\alpha \quad (3.23)$$

Summing this equation for all slices and introducing the boundary condition that the sum of the E forces for all slices must be zero yields,

$$\sum [W - (X_j - X_{j-1})] \tan\alpha - \sum S \sec\alpha = 0 \quad (3.24)$$

If the values of the X forces satisfy Eq. 3.24, then the implied E forces will satisfy their boundary condition and the system will be in horizontal as well as in vertical equilibrium. If Eq. (3.24) is not satisfied a new set of values of X must be assumed until one is found which satisfies both Eqs. 3.22 and 3.24.

Even though these two equations may be satisfied, their particular solution may not be reasonable. So far the n moment equilibrium equations for individual slice have not been considered; however, since the overall moment equilibrium equation which has been employed makes one of these equations redundant, only n-1 independent equations remain to be satisfied. From these equations the n-1 unknown coordinates for (y_t) , which define the locations of the side forces, may be calculated. Even though it is not necessary to solve these remaining equations to find a solution for the factor of safety which satisfies all conditions of equilibrium, the reasonableness of the solution may be judged from the position of (y_t) . If an unreasonable (y_t) is calculated from those equations, it is necessary to find another of infinite number of possible solutions to Eqs 3.22 and 3.24 by assuming new sets of values for X.

Bishop's Modified Procedure

The simplest solution satisfying Eq. (3.22) is obtained by assuming that there are no interslice shear forces ($X=0$).

For this assumption the boundary condition (Eq.3.11) is satisfied and Eq.(3.22) may be solved for the single unknown factor of safety. Although the normal forces (N) need not be evaluated to calculate the factor of safety, they may be determined from Eq.(3.6) and (3.17). The assumption that there are no interslice shear forces was made by Bishop to simplify the solution and is commonly referred to as the Modified Bishop procedure. The balance of equations and unknowns which are involved in the solution by this procedure are:

Equations

1	Overall moment equilibrium equation
n	Vertical force equilibrium equation for individual slices
<hr/>	
n+1	Total equations

Unknowns

1	Factor of safety
n	Normal forces on the base of each slice
<hr/>	
n+1	Total unknowns.

In general the assumption that $X=0$ will not result in a solution satisfying complete equilibrium and having a reasonable (y_t). Therefore, the solutions satisfying complete equilibrium will generally have non-zero values for X and give a somewhat different value for the factor of safety than the value calculated by Bishop's Modified procedure.

Spencer's Procedure

Spencer (1967) has presented a procedure for satisfying complete slice equilibrium for a circular shear surface. Assuming that the normal forces were located at the center of the base of each slice, Spencer achieved statical determinancy with the additional assumption that all side forces (Z) are parallel.

the locations of the normal forces on the base of each slice are thus fixed; however, their exact locations may only be determined once the necessary equilibrium solution is found for the differential moment equilibrium equation may be expressed from Eq.(3.8) as

$$- X = E \frac{dy_t}{dx} + h_t \frac{dE}{dx} \quad (3.26)$$

3.3. PROCEDURES OF SLICES SATISFYING FORCE EQUILIBRIUM

The procedures of slices which fully satisfy the three conditions of equilibrium are usually lengthy and not amenable to hand calculation. If instead only the requirements of force equilibrium are considered, procedures may be developed which are suitable for hand calculation; however, the inaccuracies introduced by the improper side force assumptions, and their resulting normal stress distributions, will be reflected to a greater degree in the force equilibrium equations than in the equations of moment equilibrium. For example, the Ordinary Method of Slices assumption for normal stress involves no error in the factor of safety for $\phi = 0$ providing that overall moment equilibrium is satisfied; however, the factor of safety calculated from a force equilibrium solution using the same normal stress assumption would be somewhat in error.

By considering only the requirements of force equilibrium, it becomes unnecessary to determine the locations of any of the forces on the sides and bases of the slices; thus, the mathematical formulations are considerably simplified, particularly for a non-circular shear surface. The equations and unknowns involved in these formulations for force equilibrium are given in Table 3.2. In order to obtain a solution satisfying force equilibrium the assumptions made most frequently relate to either the interslice shear forces (X) or the side force inclinations(β).

TABLE 3.2

Equations and Unknowns Associated With Force Equilibrium For Each Slice

Equations

n	Vertical force equilibrium equations for individual slices
n	Horizontal force equilibrium equations for individual slices.
<hr/>	
2n	Total equations

Unknowns

1	Factor of safety (F)
n	Normal forces on the base of each slice(N)
n-1	Interslice normal forces (E) or n-1 Resultant interslice forces (Z)
n-1	Interslice shear forces (X) n-1 Inclinations of resultant interslice forces(β)
<hr/>	
3n-1	Total unknowns.

A. Side Force Assumptions

Use of the Moment Equation

Although moment equilibrium is not necessarily satisfied by the side force assumptions used in a force equilibrium solution, if the side force assumptions correspond to the general characteristics of the side forces satisfying moment equilibrium, then those assumptions will lead to a more accurate procedure for analysis than a procedure which employs totally arbitrary side force assumptions. The general characteristics of side forces which satisfy moment equilibrium may be determined by studying the differential moment equation (Eq.3.26) for an individual slice.

The implications of this equation may be more readily determined if it is written in terms of the side force inclination ($\tan\beta$) as,

$$\tan\beta = - \frac{dy_t}{dx} - \frac{h_t}{E} \frac{dE}{dx} \quad (3.27)$$

From this equation it may be noted that if the two terms on the right hand side are of opposite sign, then the side forces will be somewhat less steeply inclined than the line of thrust. For a typical line of thrust and distribution of E forces such as shown in Fig.3.5 it may be noted that these two terms are of opposite sign along most of the upper half of the length of the shear surface; thus along this portion of the shear surface the side forces are flatter than the line of thrust.

Lowe and Karafiath's Assumption

Lowe and Karafiath (1960) have suggested that the inclination of the side forces may be reasonably assumed to be equal to the average inclinations of the shear surface and

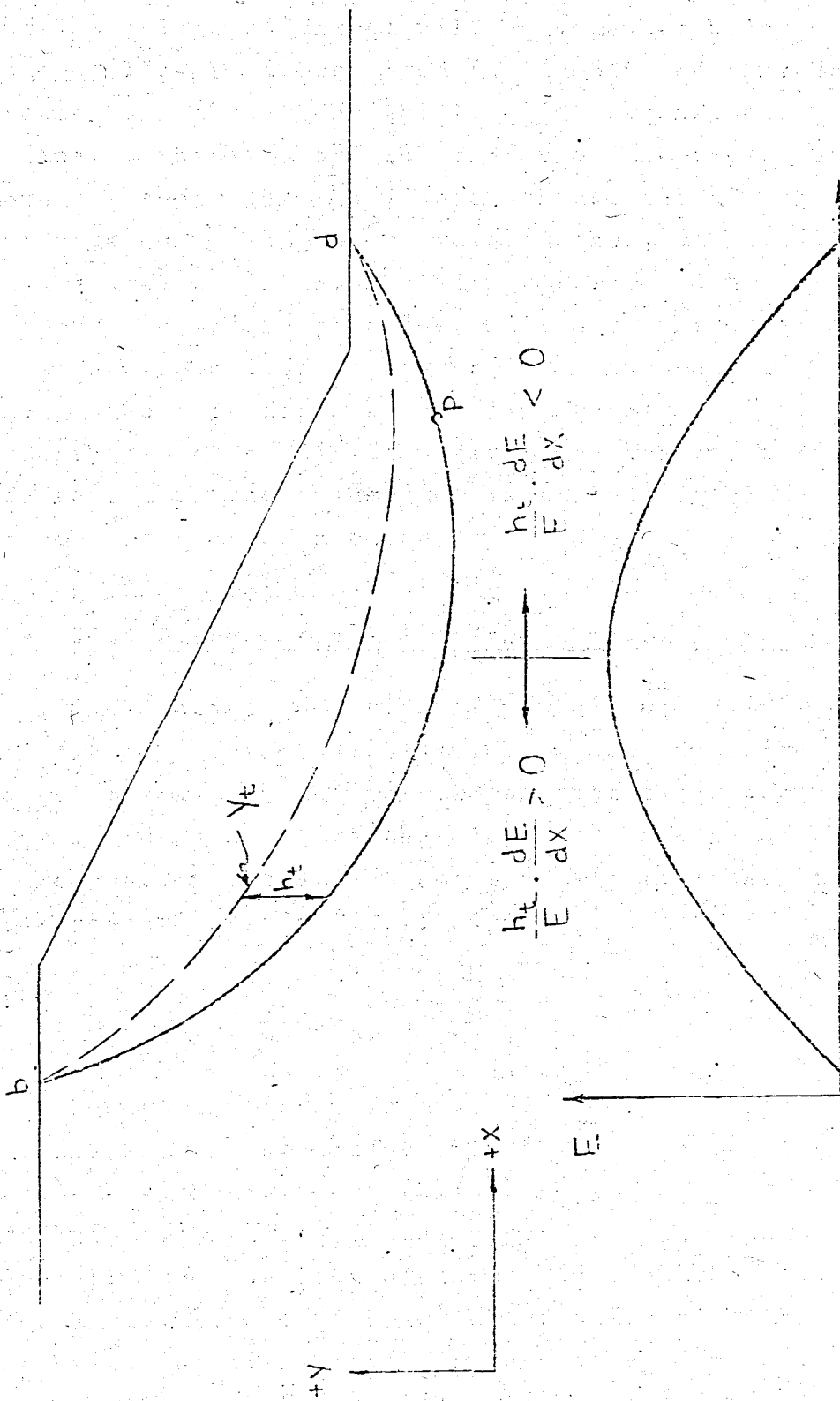

Fig. 3.5. Line of thrust and interslice normal forces for a typical shear surface.

slope face. This assumption is equivalent to assuming that the side forces are parallel to an imaginary tangent line drawn at midheight through each interslice boundary. In general the line of thrust will be somewhat below this midheight line as illustrated in Fig.3.6 and therefore it may be noted that this midheight line is somewhat flatter than the line of thrust above the center of the shear surface and somewhat steeper than the line of thrust along much of the lower portion of the shear surface. Thus, it may also be noted that the inclination of the side forces, which are assumed tangent to the midheight line, will have the same characteristics as those side forces satisfying moment equilibrium. Although the side force assumption suggested by Lowe and Karafiath cannot be directly verified from the moment equation, it appears that the assumption is at least qualitatively correct over a major portion of the slope.

Side Forces Parallel to the Line of Thrust

One special condition of some interest is that in which the side forces are assumed to act in a direction parallel to the line of thrust, so that the slope of the side forces would be equal to the slope of the line of thrust. If this assumption satisfied moment equilibrium the second term in the moment equation (Eq.3.26) must be zero; thus,

$$\frac{h_t}{E} \cdot \frac{dE}{dx} = 0 \quad (3.28)$$

However, because in general $\frac{dE}{dx}$ is not equal to zero, Eq.(3.28) will be satisfied only if the line of thrust is coincident with the shear surface ($h_t = 0$). Thus, if moment equilibrium is satisfied, the assumption that the side forces are parallel to the line of thrust implies that the line of thrust is coincident with the shear surface. Although a force equilibrium solution, based on the assumption that the side forces were parallel to a line of thrust coincident with the

shear surface, would satisfy moment equilibrium, such a completely unreasonable line of thrust might lead to a large inaccuracies in the factor of safety.

B. Lowe and Karafiath's Procedure

Lowe and Karafiath (1960) have presented a relatively simple procedure for obtaining a force equilibrium solution. As previously explained, they assumed that the side forces act at the average inclination of the shear and slope surfaces; thus eliminating the $n-1$ unknowns relating to side force, inclination and making the system of $2n$ equations statically determinant.

A solution by this procedure is commonly obtained graphically by first assuming a factor of safety and drawing the force polygons from slice to slice as illustrated in Fig. (3.7). If the polygon for the last slice fails to close, then a new factor of safety is assumed and the procedure is repeated until the closure is obtained. A numerical technique similar to the graphical procedure has also been developed.

C. Corps of Engineers' Wedge Analysis

A particular force equilibrium solution is used by the U.S. Army Corps of Engineers employing only three slices: an active and passive wedge and a central block, as illustrated in Fig. 3.8. The inclinations which are assumed for the side forces vary from parallel to the slope to horizontal. The particular values for these inclinations are determined by the position of the sliding blocks with respect to the slope and are discussed in detail in the U.S. Army Corps of Engineers Stability Manual (1968). Once the side force inclinations are assumed, a solution is obtained by the same techniques used in the general force equilibrium procedure previously described.

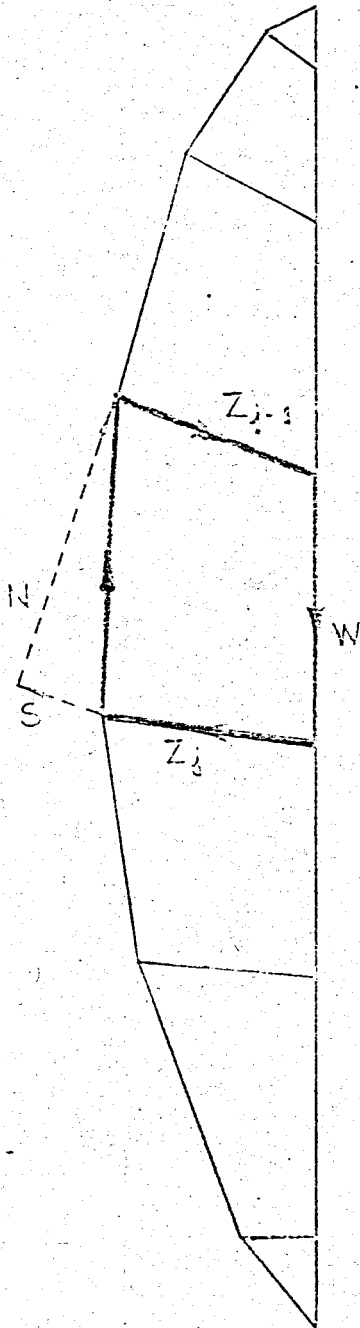

Fig.3.7. Force equilibrium polygons.

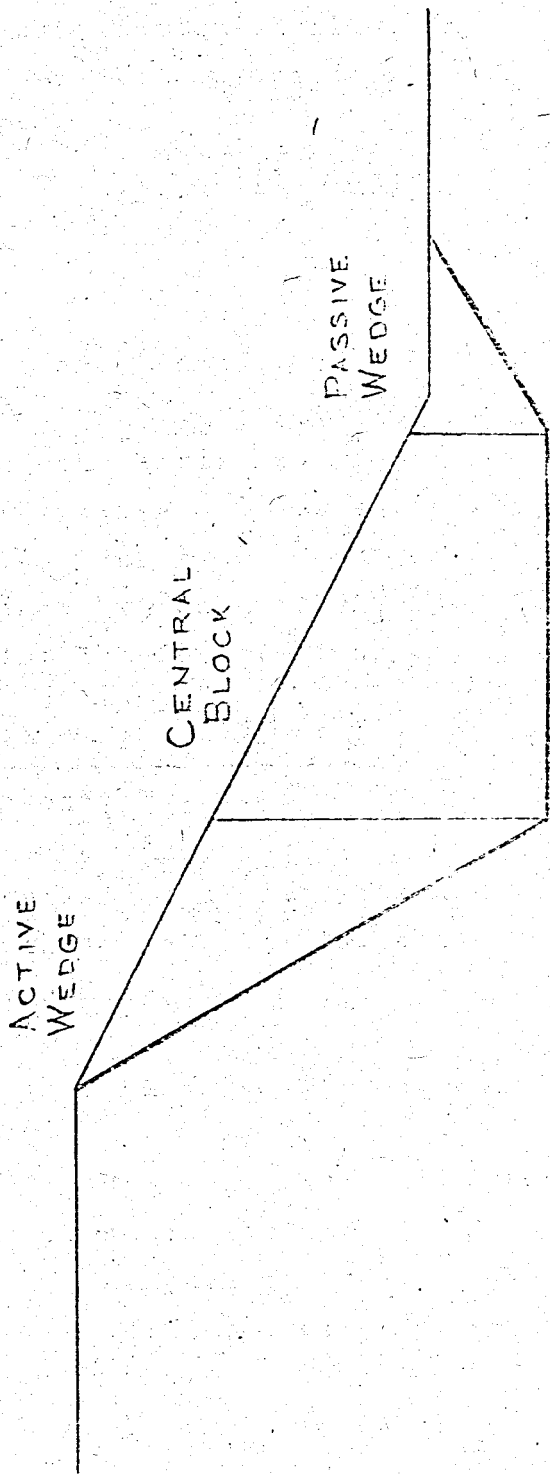

Fig. 3.8. Corps of Engineers' sliding block analysis (1968)

D. Janbu's Generalized Procedure of Slices

An expression for the factor of safety based on the requirements of force equilibrium for each slice may be obtained by using the following equations of vertical force equilibrium and force equilibrium parallel to the base of each slice which have been stated previously as

$$S = \frac{1}{F} \{c' \Delta x + [W - (X_j - X_{j-1}) - u \Delta x] \tan \phi\} k_\alpha \quad (3.20)$$

and

$$\Sigma [W - (X_j - X_{j-1})] \tan \alpha - \Sigma S \sec \alpha = 0 \quad (3.24)$$

As previously explained the horizontal force equilibrium boundary condition $[\Sigma (E_j - E_{j-1}) = 0]$ is satisfied by the formulation of Eq. (3.24). These two equations of force equilibrium were combined by Janbu (1955) to obtain the following expression for the factor of safety:

$$F = \frac{\Sigma \{c' \Delta x [W - (X_j - X_{j-1}) - u \Delta x] \tan \phi'\} \sec \alpha k_\alpha}{\Sigma [W - (X_j - X_{j-1})] \tan \alpha} \quad (3.29)$$

This equation satisfies all conditions of force equilibrium providing that the values of these forces, X , satisfy the boundary condition:

$$(X_j - X_{j-1}) = 0 \quad (3.11)$$

Janbu (1957, 1968) has shown that values of the vertical side forces for use in force equilibrium solutions may be obtained by systematic use of the requirements of moment equilibrium. These vertical forces may be expressed by the moment equation as:

$$X = - E \frac{dy_t}{dx} - h_t \frac{dE}{dx} \quad (3.26)$$

Thus, if the values of y_t are assumed, the forces, X , are given by Eq.3.26 as a function of E alone. However, although satisfaction of either this differential moment equation on the moment equation for a finite slice (Eq.3.8) is desirable, this cannot be done in a straight forward manner if the $n-1$ values of y_t are assumed. The solution of these equations are long and difficult as can be seen from the equations and unknowns given in Table 3.1.

Janbu's Approach

Janbu (1957, 1968) has presented a more logical procedure for using the conditions of moment equilibrium to estimate values of the vertical side forces, X . A solution by Janbu's Generalized Procedure of Slices (GPS) is begun by assuming the values of X in Eq.(3.29). These values are commonly assumed zero for the first step of the analysis. Once the initial factor of safety (F_0) has been calculated, Eqs.3.20 and 3.23 are used to evaluate the magnitudes of the horizontal side forces (E) using an assumed line of thrust. From these calculated values of E a numerical or graphical approximation $\frac{dE}{dX}$ is made for each interslice boundary and new values of X , which are not equal to zero, are calculated using Eq.(3.26). This procedure is then repeated until the change in the calculated value of F is within the desired accuracy on consecutive iterations.

Although the approximate numerical evaluation $\frac{dE}{dX}$ by Janbu's procedure does not precisely satisfy moment equilibrium for each slice, the error is apparently quite small. Once a solution is found, the n locations of the normal forces could be adjusted to satisfy the n equations of moment equilibrium of slice of finite width. This adjustment of the locations of the normal forces on the base of each slice would have no effect on the force equilibrium solution already found and these calculated locations of the normal force required for moment equilibrium of each slice would provide a means of

evaluating the reasonableness of the solution obtained. However, in practice these locations are seldom calculated.

E. Janbu et.al. Simplified Procedure

In the derivation of Eq.(3.29) no assumptions were made and therefore a solution remains indeterminate until n-1 assumptions are made. In place of calculating the n-1 values of the vertical side forces using the moment equation, Janbu et.al. (1956) developed a simplified force equilibrium procedure based on the assumption that there are no interslice shear forces. With these forces (X) equal to zero Eq.(3.29) becomes.

$$F_o = \frac{\Sigma \{ [c' \Delta x + (W - u \Delta x) \tan \phi'] \sec \alpha k_o}{W \tan \alpha} \quad (3.30)$$

in which F_o is the force equilibrium factor of safety for horizontal interslice forces. The assumption made eliminates n-1 unknown magnitudes of X, leaving the following unknowns to be determined using 2n equations of force equilibrium:

Unknowns

1	Factor of safety (F_o)
n	Normal forces on the base of each slice (N)
<u>n-1</u>	<u>Interslice normal force (E)</u>
2n	Total unknowns

Although the simplifying assumption made by Janbu et.al. is identical to the assumption made in the Modified Bishop procedure, the conditions of equilibrium which are satisfied are not the same. The Modified Bishop procedure satisfied overall moment equilibrium and vertical force equilibrium for each slice while the simplified procedure of Janbu et.al. satisfies vertical and horizontal force equilibrium for each slice.

Assuming that the side forces are horizontal always underestimates the factor of safety based on a force equilibrium solution. In order to obtain an improved value of the factor of safety, Janbu et.al. have presented the correction factors shown in Fig.3.9. The corrected factor of safety is obtained by multiplying F_0 by the appropriate value of f_0 from Fig.3.9. According to this figure the required correction may be as high as 13 percent and the maximum error introduced into the simplified solution by the assumption of zero vertical side forces occurs when ϕ is equal to zero.

3.4. CONCLUSIONS

In this chapter the procedures of detailed stability analysis in which the soil mass is divided vertically into a number of slices are discussed. The similarities and differences in the various procedures may be examined in terms of the conditions of equilibrium which they satisfy and the assumptions they employ to achieve statical determinancy. Any procedure satisfying an equilibrium condition for each slice automatically satisfies that same condition for the entire mass bounded by the shear surface.

The accuracy of the various procedures of analysis is not necessarily related to the number of equilibrium conditions satisfied. For example the Modified Bishop Method Solution, which satisfies only $n+1$ equilibrium conditions, may yield a better value for the factor of safety than a force equilibrium procedure using the same side force assumption and satisfying $2n$ conditions of equilibrium. Furthermore, two procedures may satisfy the same conditions of equilibrium yet fail to give equally satisfactory solutions for the factor of safety. For example the $3n$ equilibrium equations are satisfied by Spencer's procedure which assumes that the side forces on all slices are parallel; however, the solution which is found may in some cases result in an unreasonable line of thrust.

Consequently a more reasonable solution to the same 3n equations may sometimes be obtained using the Morgenstern and Price procedure and employing some other assumption regarding side force orientations.

For some of the procedures such as Bishop's procedure, Morgenstern and Price procedure, and Janbu's Generalized procedure of Slices, the assumptions regarding the unknowns are determined to some degree by the user and thus more than one valid solution may be found.

From the standpoint of mechanics it is desirable to use a procedure satisfying equilibrium as completely as is reasonably justified with respect to both accuracy and effort. However, for methods which do not satisfy all conditions of equilibrium it appears that the condition of moment equilibrium should be considered of somewhat greater importance (especially for $\phi = 0$ soils) than force equilibrium. For this reason the Ordinary Method of Slices and Bishop's Modified Method are used in the calculations on the forthcoming chapter.

4. STABILITY OF FILLS ON SOFT FOUNDATION

4.1. INTRODUCTION

The differences between the values of the factor of safety calculated by various analysis procedures, for inhomogeneous slopes, may be much larger than for the homogeneous slopes discussed in Chapter 2.

To investigate the possible differences among the results obtained by using the various analysis procedures (Only Analyses by Procedures Satisfying Moment Equilibrium; namely Ordinary Method of Slices and Bishops' Modified Method are used since it is shown in chapter 3 that for $\phi = 0$ soils the procedures of slices satisfying moment equilibrium yield more reasonable factor of safety than the procedures of slices satisfying force equilibrium), to determine the effects of strength parameters on the Factor of safety and to determine which procedures may be the most applicable for analysis of slopes in inhomogeneous soil conditions, an example was selected: A cohesionless fill on a clay foundation. The

example is studied in three different cases in which the shear strength and the geometry of the cohesionless fill and the clay foundation are varied. The effect of the fill shear strength when the subsoil shear strength is constant, the effect of the constant subsoil shear strength and the effect of linear variation of subsoil shear strength with depth to the variation of the factor of safety and the corresponding critical circles trajectories are investigated.

The example is studied by using the computer program for Ordinary Method of Slices and Bishop's Modified Method of Stability Analysis, developed by Durgunoğlu(1973). More than 150 runs are performed, whence more than 3000 possible factor of safety values are checked to solve the problems.

4.2. EFFECT OF FILL SHEAR STRENGTH CONSTANT SHEAR STRENGTH OF SUBSOIL

It is intended to find the variation of the factor of safety with respect to the slope height, H_f , for varying soil properties of the fill layer, when the subsoil properties remain constant.

For the systematic evaluation of the minimum factor of safety, the values of the slope height, H_f , the unit weight of the fill material, γ_f , the internal friction angle ϕ , of the fill material are varied, and for each set of values the possibility of deep circle and partly the possibility of the toe circle are investigated. The slope of the fill material taken as 1/1,5 is kept constant during the study. For slope height, H_f , 3 different values as $H_f = 4, 6, 8$ m, for unit weight of the sand layer again 3 different values as $\gamma_f = 1.9, 2, 2.1$ t/m³, for internal friction angle of the sand layer 3 different values as $\phi = 35^\circ, 40^\circ, 45^\circ$ are chosen respectively. The subsoil is taken as normally consolidated clay with undrained shear strength of 3 t/m², unit weight of 2 t/m³. The thickness

of the subsoil layer is constant and equal to three times the height of the fill, H_f .

The table 4.1 and Fig.4.1. give complete data of the study. The results of the study is tabulated in Tables A1-A15 and summarized in Tables 4.2. and 4.3.

The geometry and the possible critical circle coordinates used to calculate the minimum factor of safety for different fill heights both by the Ordinary Method of Slices and the Bishop's Modified Method are shown in Fig's A1 through A3 in the Appendix.

In this analysis two different factors are studied separately.

1- It is assumed that the increase in fill strength is accompanied by an increase of the fill's unit weight. In this case it is assumed that for fill material with different compactness the following average values could be utilized:

<u>Fill</u>	<u>ϕ - degree</u>	<u>γ-t/m³</u>
Loose	35°	1.9
Medium	40°	2.0
Dense	45°	2.1

The factor of safety corresponding to the critical circle determined using both Ordinary Method of Slices (OMS) and Bishop's Modified Method (BM) are given in Table 4.2. and the detailed analysis are presented in Tables A1-A9 given in the Appendix.

The values determined are plotted as a function of the slope height, H_f , and the fill material shear strength as shown in Fig's 4.2. and 4.3.

2- It is assumed that the fill material has a constant

unit weight which is taken as $\gamma = 2.0 \text{ t/m}^3$, but the friction angle of the fill material is varied. The factor of safety corresponding to the critical circle determined using both Ordinary Method of Slices and Bishop's Modified Method are given in Table 4.3. and the detailed analysis are presented in Tables A2, A5, A8 and A10 through A15.

The values determined are plotted as a function of the slope height, H_f and the fill material shear strength as shown in Fig. 4.4. and 4.5.

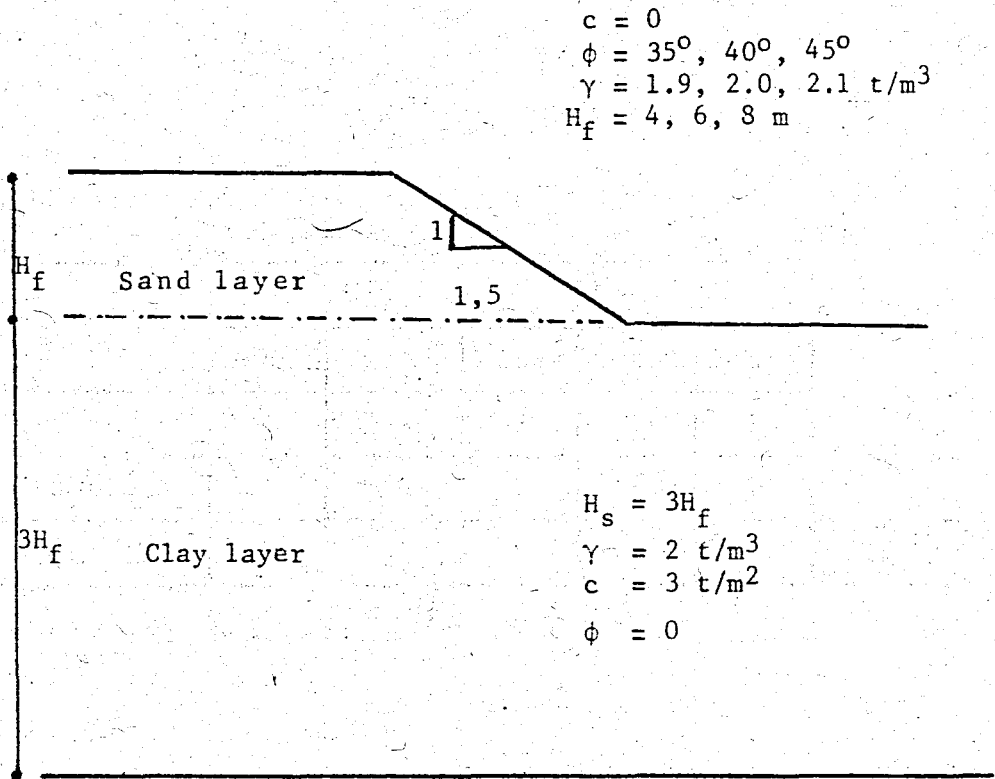

Fig4.1. Geometry and soil properties for studying the effects of fill material

TABLE 4.1. Runs for studying the Effect of Fill Material

Fill Height H_f	Variable γ_f			Constant γ_f	
	Loose	Medium	Dense	Loose	Dense
4 m	1	2	3	10	11
6 m	4	5	6	12	13
8 m	7	8	9	14	15
Total No of Runs 15					

Subsoil Properties:

$$C = 3 \text{ t/m}^2$$

$$\phi = 0^\circ$$

$$H_s = 3 H_f$$

$$\gamma = 2 \text{ t/m}^2$$

TABLE 4.2. Summary of Results (for variable fill density)

Fill Height H_f , m	Factor of Safety					
	OMS ¹	BM ²	OMS	BM	OMS	BM
4.0	1.885	2.084	1.837	2.008	1.787	1.930
6.0	1.307	1.420	1.265	1.360	1.224	1.303
8.0	1.002	1.075	0.968	1.026	0.935	0.982

Subsoil Properties:

$$C = 3 \text{ t/m}^2$$

$$\phi = 0^\circ$$

$$\gamma = 2 \text{ t/m}^3$$

$$H_s = 3 H_f$$

(1) OMS: Ordinary Method of Slices

(2) BM : Bishop's Modified Method.

TABLE 4.3. Summary of Results (for fixed fill density) (1)

Fill Height H_f , m	Factor of Safety					
	LOOSE($\phi=35^\circ$)		MEDIUM($\phi=40^\circ$)		DENSE($\phi=45^\circ$)	
	OMS	BM	OMS	BM	OMS	BM
4.0	1.801	2.004	1.837	2.008	1.871	2.023
6.0	1.247	1.352	1.265	1.360	1.280	1.366
8.0	0.956	1.023	0.968	1.026	0.979	1.044

Subsoil Properties:

$$C = 3 \text{ t/m}^2$$

$$\phi = 0^\circ$$

$$\gamma = 2 \text{ t/m}^3$$

$$H_s = 3 H_f$$

(1) Constant unit weight of fill material of 2 t/m^3 is taken

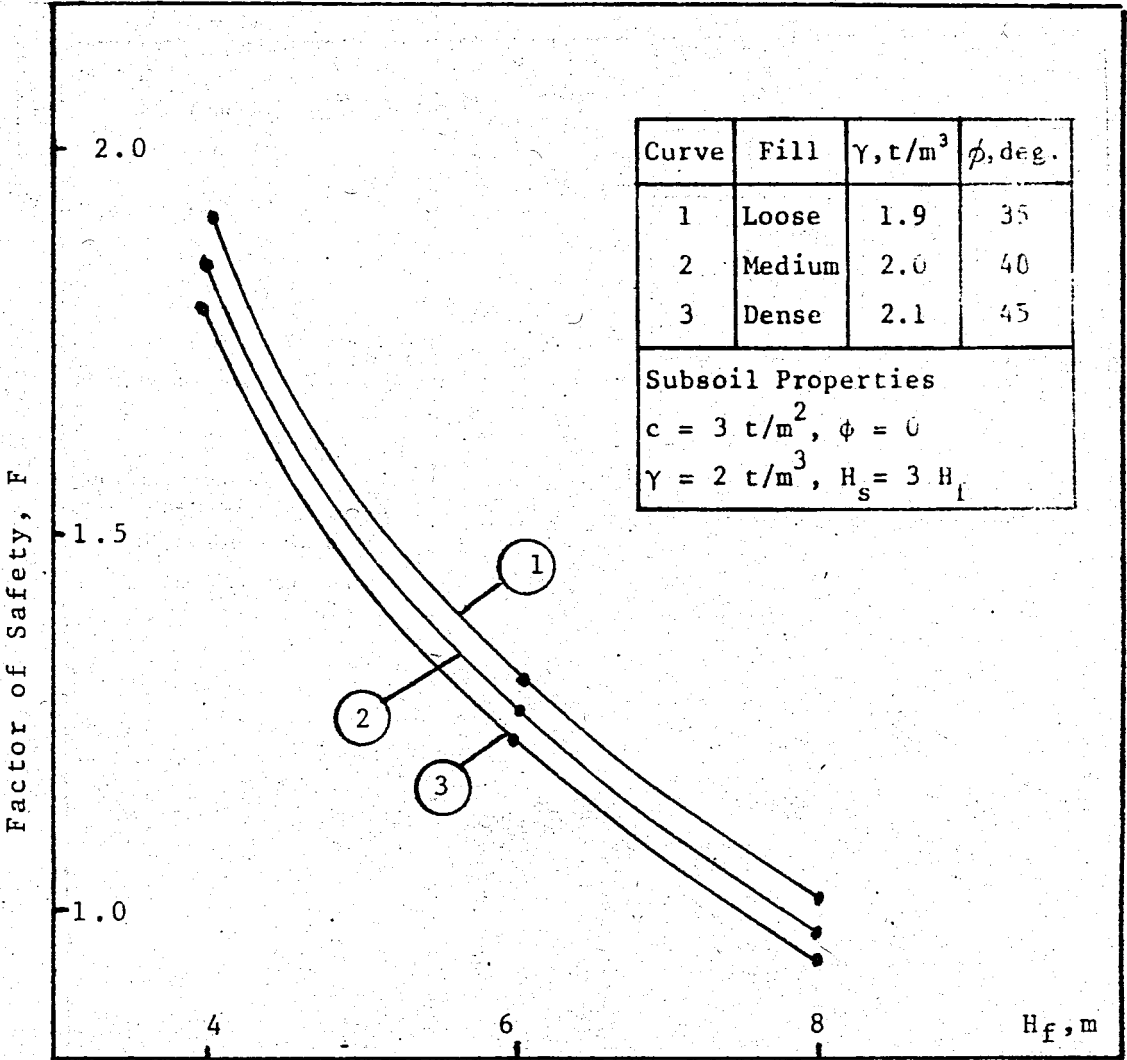

Fig. 4.2. Variation of the factor of safety with respect to slope height and for variable unit weight by Ordinary Method of Slices

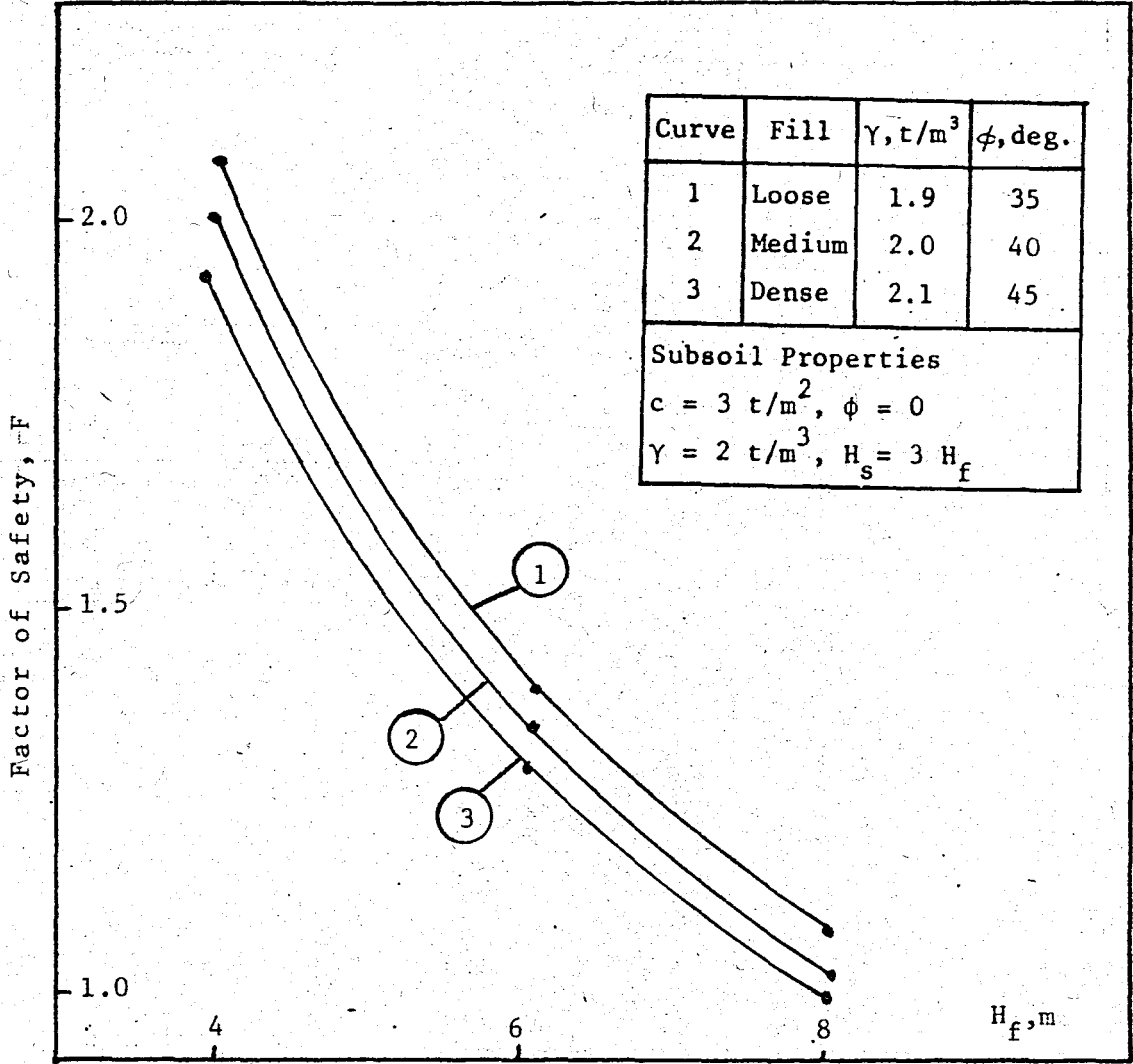

Fig. 4.3. Variation of the factor of safety with respect to slope height and for variable unit weight by Bishop's Modified Method

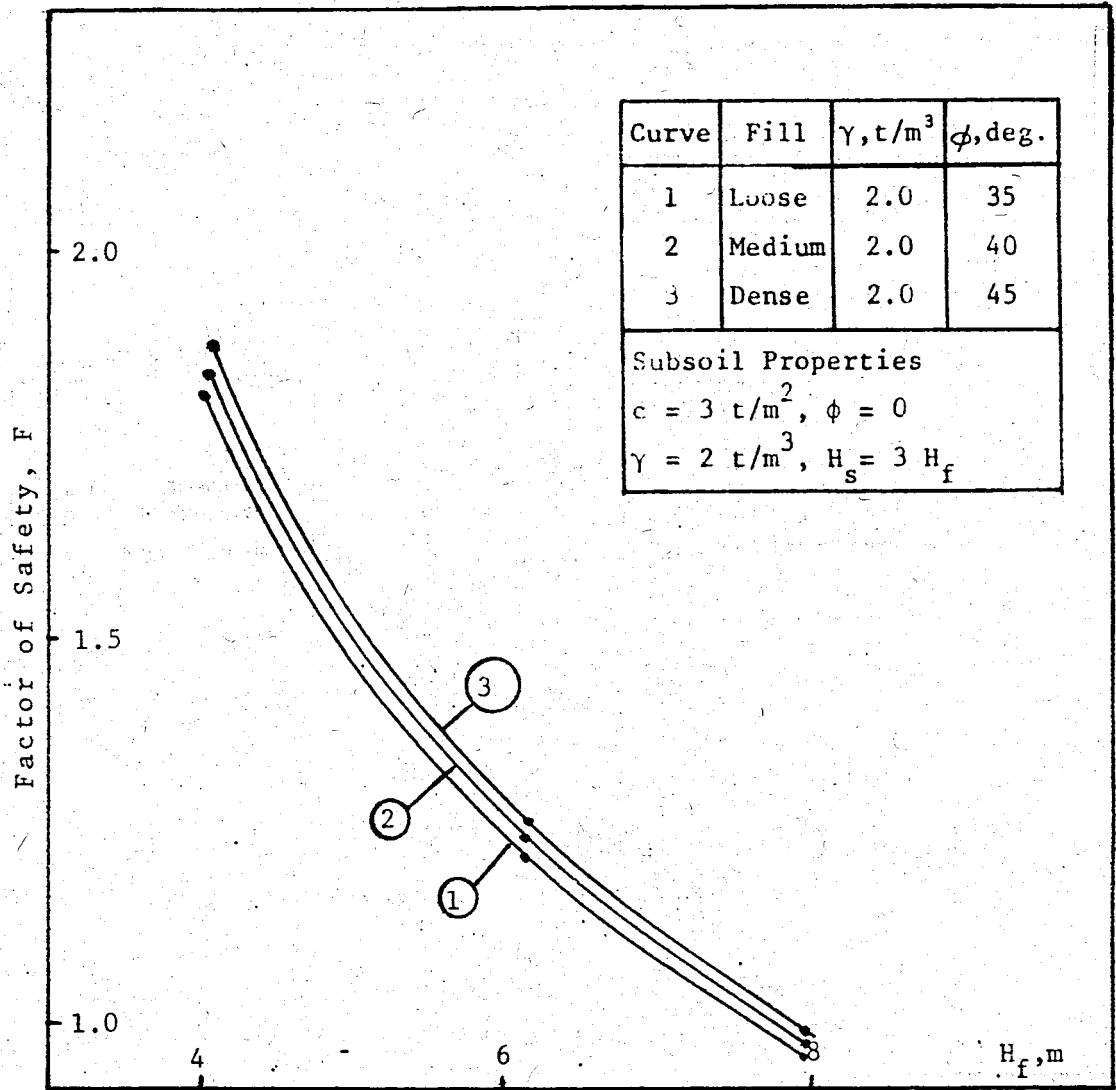

Fig. 4.4. Variation of the factor of safety with respect to slope height and for variable unit weight by Ordinary Method of Slices

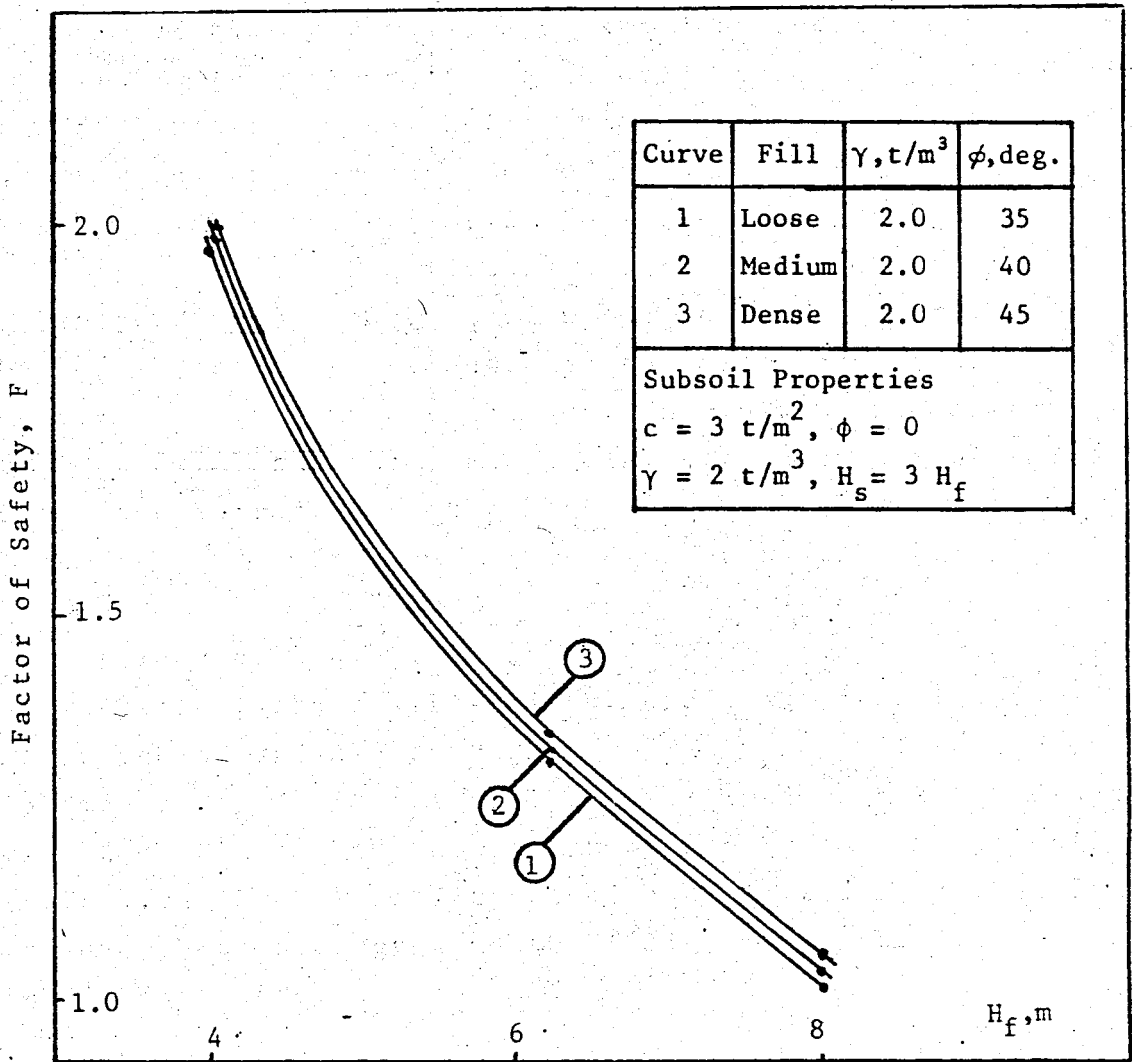

Fig. 4.5. Variation of the factor of Safety with respect to slope height and for fixed unit weight by Bishop's Modified Method

4.3. EFFECT OF CONSTANT SUBSOIL SHEAR STRENGTH

It is intended to find the variation of the factor of safety with respect to the subsoil shear strength, c , when both the fixed fill layer's and subsoil layer's shear strengths are varied.

For the systematic evaluation of the minimum factor of safety, the values of the internal friction angle " ϕ " of the fill material and the cohesion intercept of the subsoil are varied, and for each set of values the possibility of deep circle is investigated. For internal friction angle of the fill material 3 different values as $\phi = 35^\circ, 40^\circ, 45^\circ$, corresponding to loose, medium and dense state of the fill material, for shear strength of the clay layer again 3 values as $c = 3, 4.5, 6 \text{ t/m}^2$ are chosen. The unit weight of both the fill material and the subsoil clay layer are taken as 2 t/m^3 . The slope height, H_f , is taken as 4 m and the subsoil clay layer height is fixed as three times the slope height, H_f .

The Table 4.4. and the Fig. 4.6. give the complete data of the study. The results of the study is tabulated in Tables A1 through A3 and A16 through A21. The factor of safety corresponding to the critical circle determined both by Ordinary Method of Slices and Bishop's Modified Method are given in Table 4.5. The values determined are plotted as a function of subsoil shear strength and the fill's shear strength as shown in Fig's 4.7 and 4.8.

TABLE 4.4. Runs for Studying the Effect of Subsoil Shear Strength

Fill	ϕ , degree	VARIABLE SUBSOIL SHEAR STRENGTH			
		$c=3 \text{ t/m}^2$	$c=4.5 \text{ t/m}^2$	$c=6 \text{ t/m}^2$	
Loose	35	1	16	19	Total No of Runs 9
Medium	40	2	17	20	
Dense	45	3	18	21	

$$H_{\text{fill}} = 4 \text{ m}$$

$$H_s = 3 H_f$$

$$\gamma_f = \gamma_s = 2 \text{ t/m}^3$$

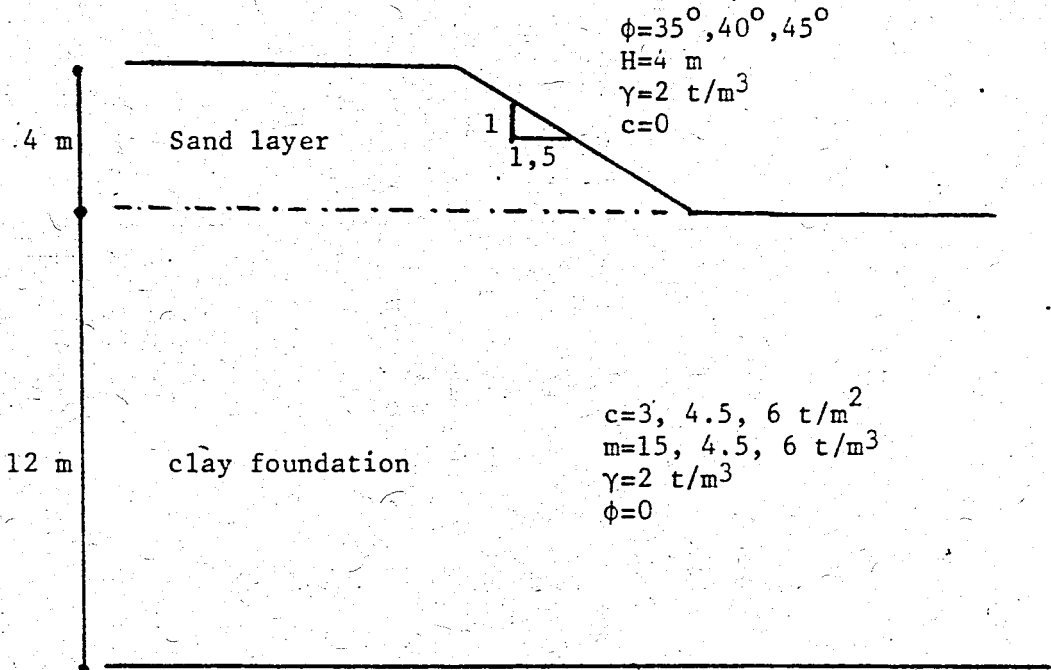

Fig. 4.6. Geometry and soil properties for studying the effects of constant linearly varying shear strength of subsoil

TABLE 4.5. Summary of Results (Variable Shear Strength of Subsoil)

Fill	ϕ -degrees	Factor of Safety					
		$c = 3 \text{ t/m}^2$		$c = 4,5 \text{ t/m}^2$		$c = 6 \text{ t/m}^2$	
		OMS	BM	OMS	BM	OMS	BM
Loose	35	1.801	2.004	2.601	2.871	3.400	3.694
Medium	40	1.837	2.008	2.640	2.933	3.440	3.779
Dense	45	1.871	2.023	2.687	2.971	3.486	3.862

$$H_{\text{fill}} = 4 \text{ m}$$

$$H_s = 3 H_f$$

$$\gamma_f = \gamma_s = 2 \text{ t/m}^3$$

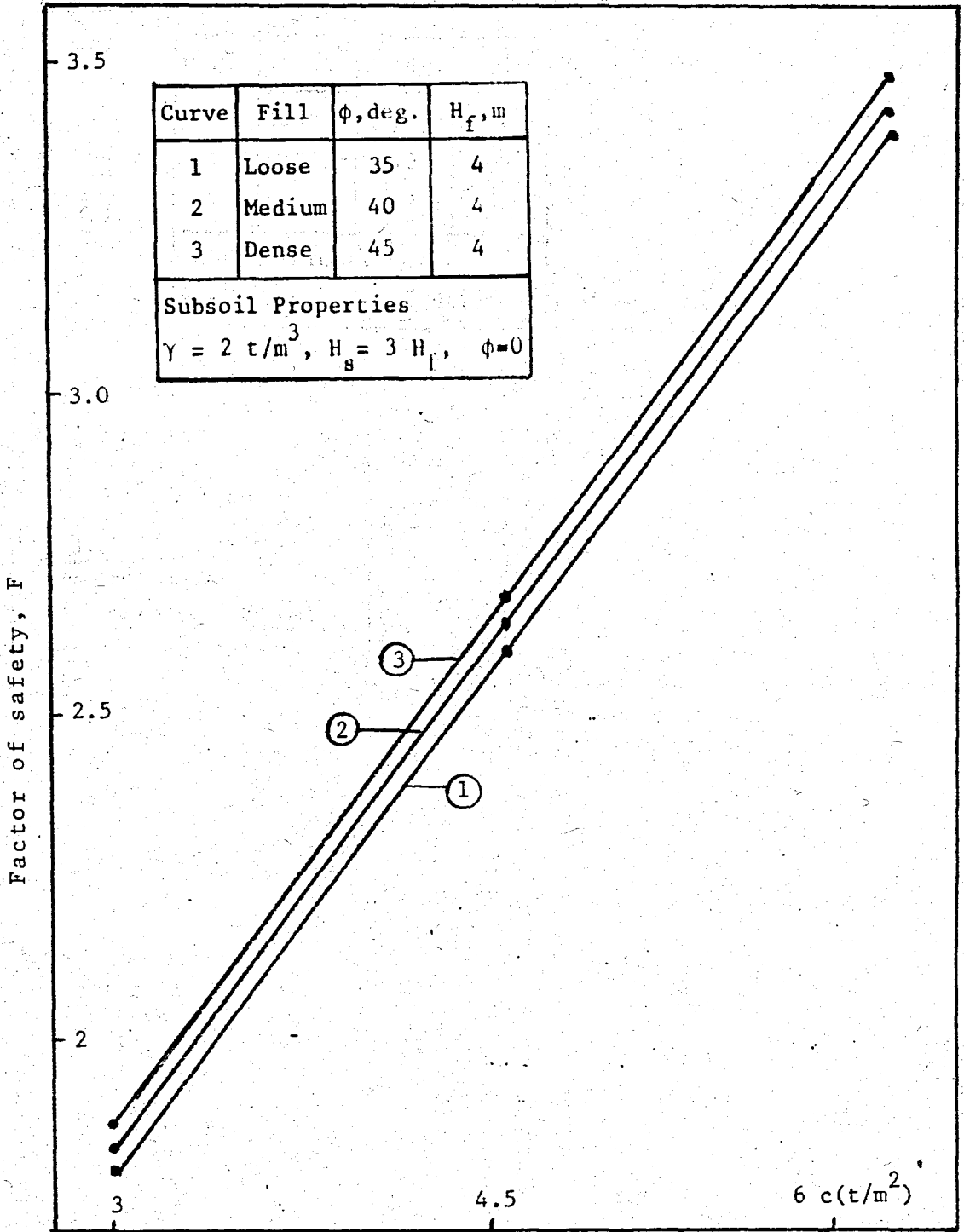

Fig. 4.7. Variation of the factor of safety with respect to constant shear strength of the subsoil by Ordinary Method of Slices

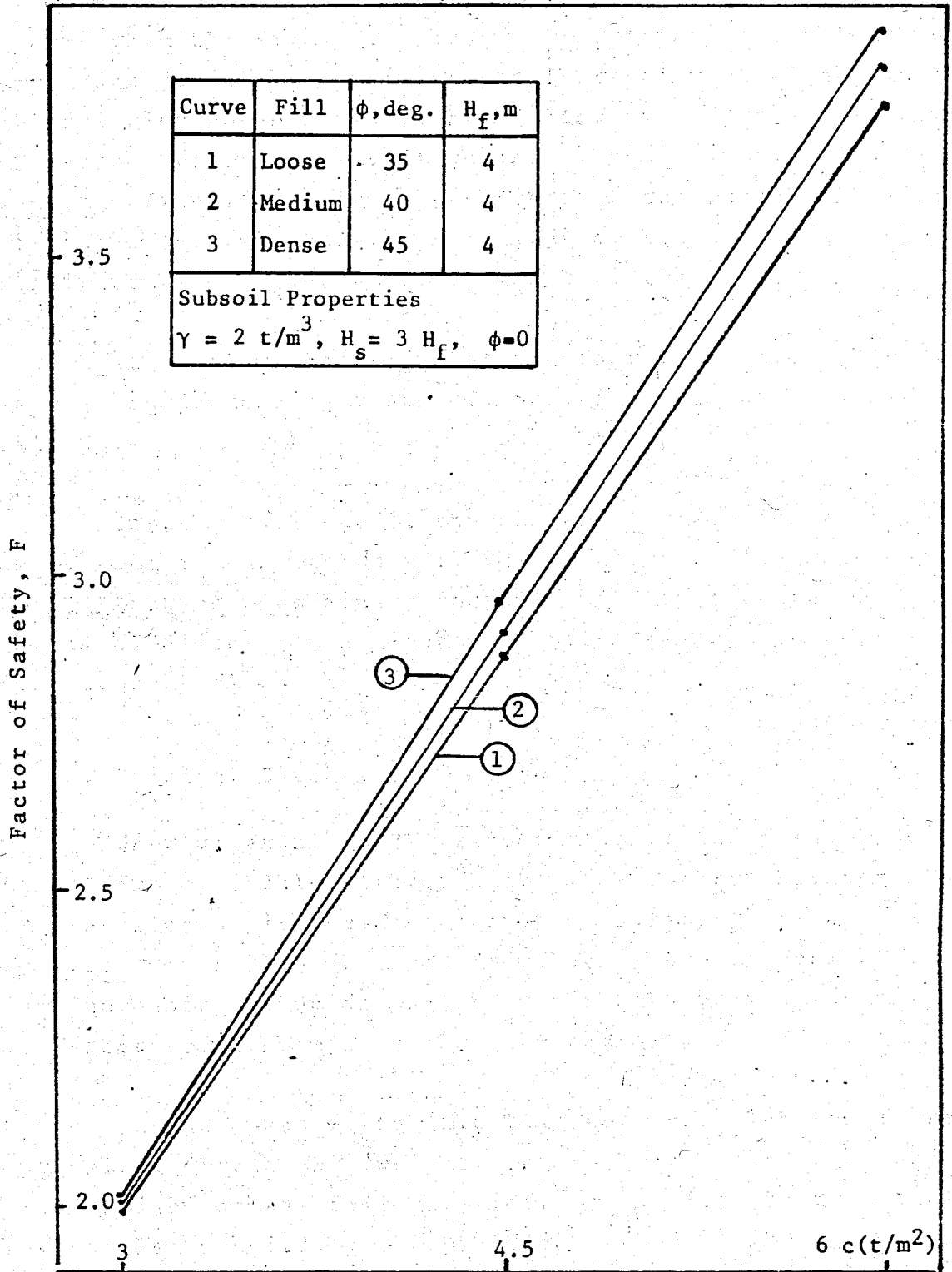

Fig. 4.8. Variation of the factor of safety with respect to constant shear strength of subsoil by Bishop's Modified Method.

A. Effect of Fill Shear Strength

When the Fig's 4.4. and 4.5. are examined, it can be seen that for a fixed unit weight the soil with higher internal friction angle gives higher factor of safety as expected. But as we increase the unit weight of the soil with its internal friction angle we observe that the factor of safety decreases with the increasing values of the unit weight and the internal friction angle (Fig's 4.2. and 4.3).

It is also observed that the factor of safety, decreases with an increasing value of the height of the fill material, H_f .

Since the effect of the slice interface forces are considered in the analysis of the Bishop's Modified Method, this method results higher factor of safety than the Ordinary Method of Slices for a given condition as shown in Tables 4.2. through 4.4.

B. Critical Circles Trajectories

When we examine the trajectories of the possible critical circles (Table A1 through A21). We observe that the deep circles always give smaller factor of safety than the toe circles. It is also observed from Tables A16 through A21 that the increasing value of the shear strength of the subsoil decreases the deepness of the critical circle.

The deepness of the circles increases with the increasing values of the unit weight, internal friction angle and the slope height of the fill material. It is also observed that the circles studied by the Modified Bishops method go deeper than circles studied by Ordinary Method of Slices

C. Effect of the Subsoil Shear Strength

For the whole range of the internal friction angle

for a fixed unit weight of and slope height of the fill material, it is observed from Fig's 4.7 and 4.8 that the subsoil shear strength, c , is directly proportional to the factor of safety, F . The effect of the subsoil shear strength becomes more pronounced when the critical circle gets more deeper because the length of the failure arc at which the shear strength acts increases.

D. Normalization of the Results

The variation of the factor of safety with respect to the slope height for different internal friction angle, for variable and constant unit weight of the fill material are plotted in Fig's 4.2. through 4.5. and the variation of the factor of safety with respect to the subsoil shear strength are plotted in Fig's 4.7 and 4.8. It is also intended to have the variation of the factor of safety with respect to a dimensionless parameter in order to obtain directly the value of the factor of safety when subsoil shear strength is known. For this purpose the graphs in figures 4.9 and 4.10 are generated. The graphs show the variation of the factor of safety, for different internal friction angles of the fill material with respect to a dimensionless parameter, t

$$t = \frac{c}{\gamma_f H_f} \quad (4.1)$$

where

c = subsoil shear strength

γ_f = Unit weight of the fill material

H_f = Height of the full material

The graphs in Fig's 4.9 and 4.10 verify the previous explanations and figures by showing that the factor of safety increases with the increasing values of the internal friction angle of the fill

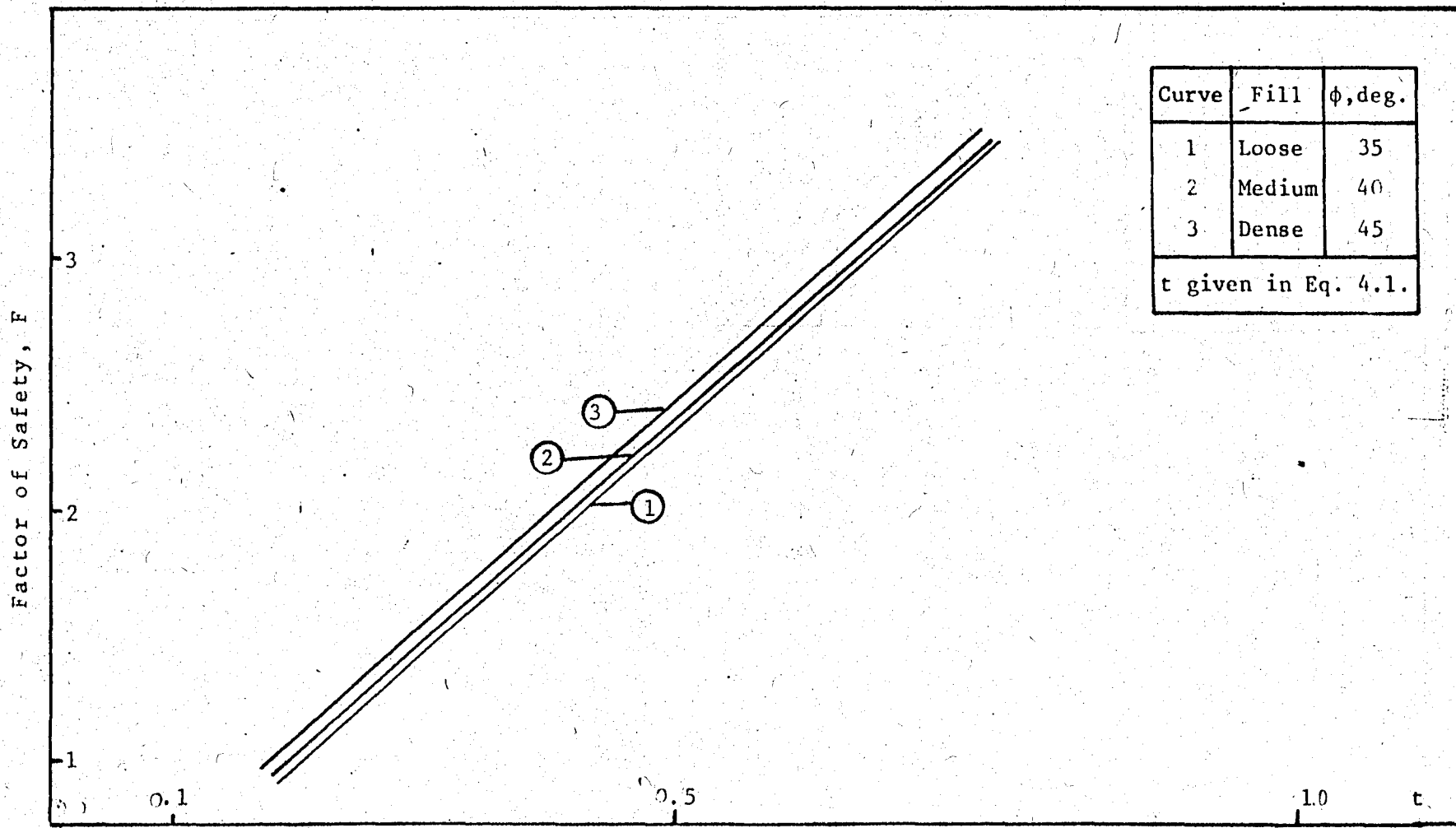

Fig. 4.9. Variation of the factor of safety with respect to dimensionless parameter, t, by Ordinary Method of Slices

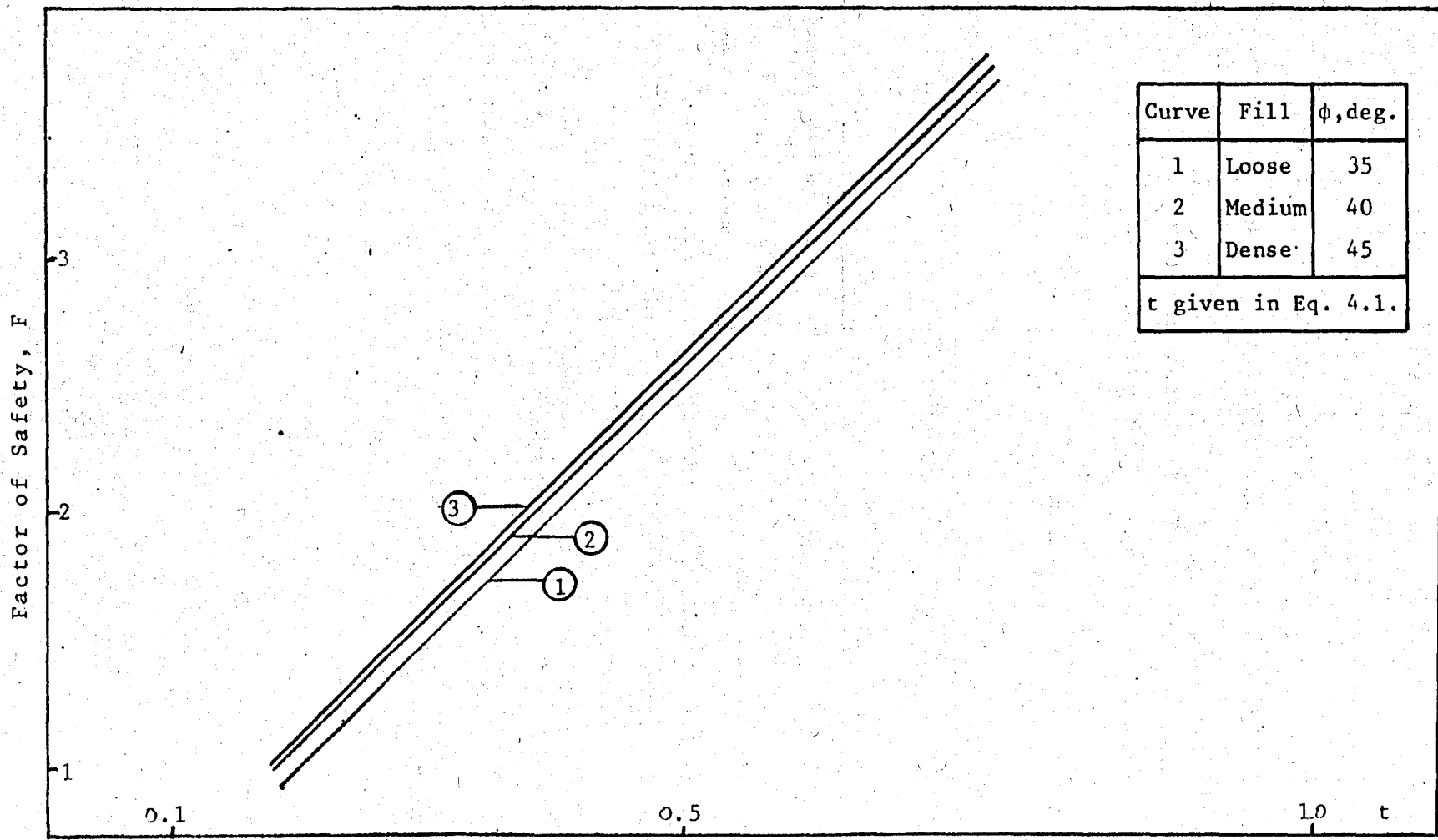

Fig. 4.10. Variation of the factor of safety with respect to dimensionless parameter, t , by Bishop's Modified Method.

material and the shear strength of the subsoil, it decreases with the increasing values of the slope height and the unit weight of the fill material.

The results obtained so far and the coordinates of the corresponding critical circles are tabulated in Tables A1 through A21. In this part of the study it is intended to normalize these results in terms of the stability number, N_s , by use of the bearing capacity failure criteria.

$$N_s = F \frac{\gamma_f H_f}{c} \quad (4.2)$$

where

- F : Factor of safety
- γ_f : Unit weight of the fill material
- H_f : Height of the fill material
- c : Subsoil shear strength.

When we back calculate the stability number, N_s (Table 4.6) we observe that the Bishop's Modified Method is more reliable than the Ordinary Method of Slices with a mean of value of the stability number of 5.331, and when the factor of safety approaches to unity the stability number is within the range of 5.14 to 5.7.

TABLE 4.6. Calculation of the stability number by use of bearing capacity failure criteria

Run No.	c_d t / m ²	γ_f t / m ³	H_f m	F		N_s	
				OMS	BM	OMS	BM
1	3	1.9	4	1.885	2.084	4.775	5.279
2	3	2	4	1.837	2.008	4.899	5.354
3	3	2.1	4	1.787	1.930	5.004	5.404
4	3	1.9	6	1.307	1.420	4.967	5.396
5	3	2	6	1.265	1.360	5.060	5.440
6	3	2.1	6	1.224	1.303	5.141	5.473
7	3	1.9	8	1.002	1.075	5.077	5.447
8	3	2	8	0.968	1.026	5.162	5.472
9	3	2.1	8	0.935	0.982	5.236	5.499
10	3	2	4	1.801	2.004	4.801	5.343
11	3	2	4	1.871	2.023	4.989	5.381
12	3	2	6	1.247	1.352	4.960	5.408
13	3	2	6	1.280	1.366	5.120	5.464
14	3	2	8	0.956	1.023	5.095	5.456
15	3	2	8	0.979	1.044	5.211	5.564
16	4.5	2	4	2.601	2.871	4.624	5.102
17	4.5	2	4	2.640	2.933	4.693	5.214
18	4.5	2	4	2.687	2.971	4.777	5.282
19	6	2	4	3.400	3.694	4.533	4.925
20	6	2	4	3.440	3.779	4.587	5.033
21	6	2	4	3.486	3.862	4.648	5.149
						$\bar{N}_s = 4.922$	$\bar{N}_s = 5.331$

c_d : Undrained shear strength of subsoil foundation

γ_f : Unit weight of the fill material

H_f : Height of the fill

F : Factor of safety

N_s : Stability number calculated using Eq.4.2.

4.4. EFFECT OF SUBSOIL SHEAR STRENGTH, LINEAR VARIATION OF SUBSOIL SHEAR STRENGTH

It is intended to find the variation of the factor of safety with respect to the rate of the shear strength of the subsoil, m .

$$m = \frac{dc}{dz} \quad (4.3)$$

where

- c : cohesion intercept of the subsoil
- z : Depth of subsoil from which the critical circle passes, for constant shear strength cases as discussed in Fig. 4.11

when both the fixed fill layer's and subsoil layer's shear strengths are varied.

For the systematic evaluation of the minimum factor of safety, the values of the internal friction angle, ϕ , of the fill material and the rate of the cohesion intercept with respect to the height, m , of the subsoil are varied, and for each set of values the possibility of deep circle is investigated both by Ordinary Method of Slices and the Bishop's Modified Method. For internal friction angle of the fill material three different values as $\phi = 35^\circ, 40^\circ, 45^\circ$ corresponding to loose, medium and dense state of the fill material, for shear strength of the clay layer again three values as $m = 1.5, 4.5, 6 \text{ t/m}^2 \cdot \text{m}$ are chosen by considering that the cohesion intercept values of the previous study ($c=3,4,5,6 \text{ t/m}^2$) being their mean values as illustrated in Fig. 4.11.

The Table 4.7 and Fig's 4.6 and 4.11 give the complete data of the study. The results of the study are tabulated in Tables A22 through A30. The factor of safety corresponding to the critical circle determined both by the Ordinary Method of Slices and Bishop's Modified Method are given in Table 4.8.

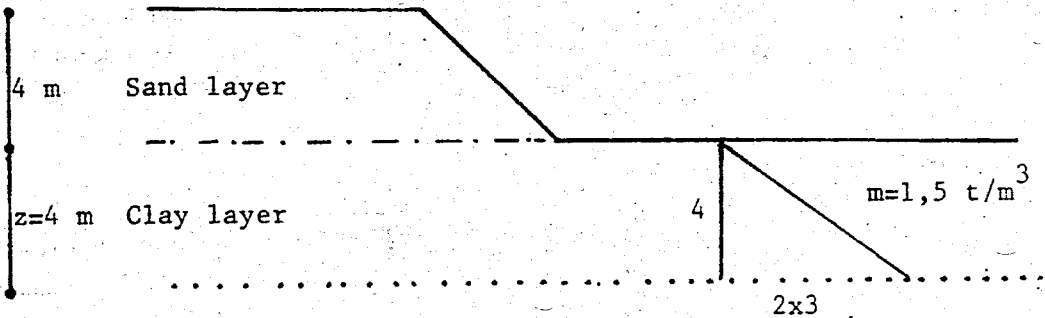

Layer from which the critical circle passes for $c=3 \text{ t/m}^2$ value

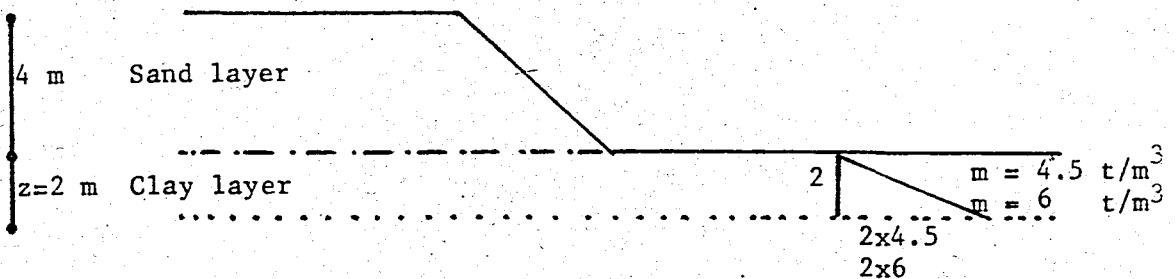

Layer from which the critical circles pass for $c=4.5$ and 6 t/m^2 values

Fig. 4.11. Figure illustrating the calculation of the slope of the shear strength, m , of the subsoil

The Values determined are plotted as a function of, m , and the fill's shear strength as shown in Fig's 4.12. and 4.13.

TABLE 4.7. Runs for studying the Effect of Subsoil Shear Strength (Linear increase of Subsoil shear strength with depth)

Fill	ϕ -degrees	LINEAR INCREASE OF SUBSOIL SHEAR STRENGTH WITH DEPTH			Total No of Run 9
		$m = 1.5 \text{ t/m}^3$	$m = 4.5 \text{ t/m}^3$	$m = 6 \text{ t/m}^3$	
Loose	35	22	23	24	
Medium	40	25	26	27	
Dense	45	28	29	30	

$$H_{fill} : 4 \text{ m}$$

$$H_s : 3 H_f$$

$$\gamma_s = \gamma_f = 2 \text{ t/m}^3$$

TABLE 4.8. Summary of Results (Linear Increase of Subsoil Shear Strength With Depth)

Fill	ϕ -degree	Factor of Safety					
		m=1.5 t/m ³		m=4.5 t/m ³		m= 6 t/m ³	
		OMS	BM	OMS	BM	OMS	BM
Loose	35	0.842	0.986	1.213	1.479	1.411	1.704
Medium	40	0.914	1.053	1.336	1.633	1.534	1.866
Dense	45	0.998	1.126	1.479	1.807	1.677	2.046

$H_{fill} : 4 \text{ m}$

$H_s : 3 H_f$

$\gamma_s = \gamma_f = 2 \text{ t/m}^3$

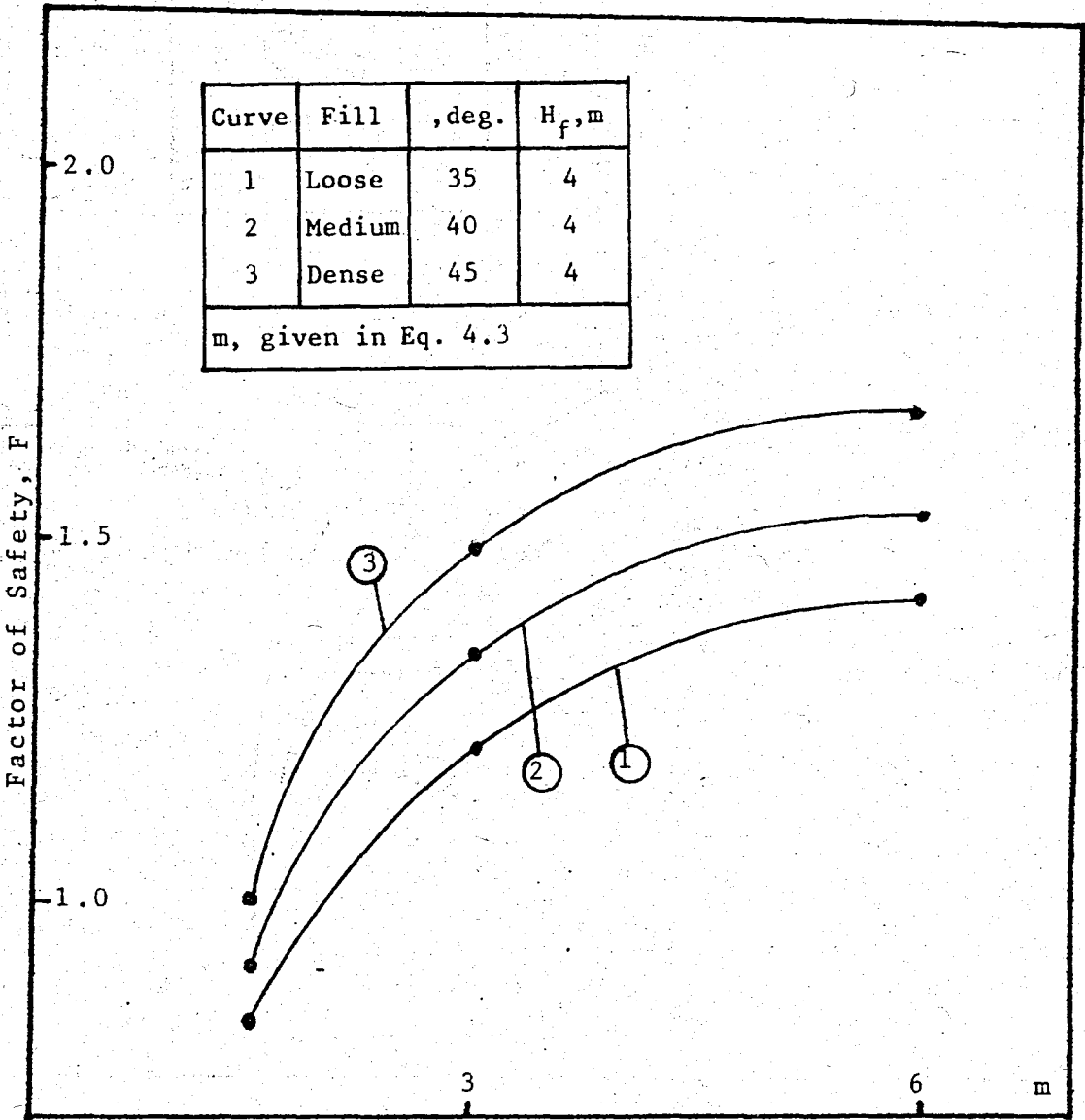

Fig. 4.12. Variation of the factor of safety with respect to slope of the subsoil shear strength, m, by Ordinary Method of slopes

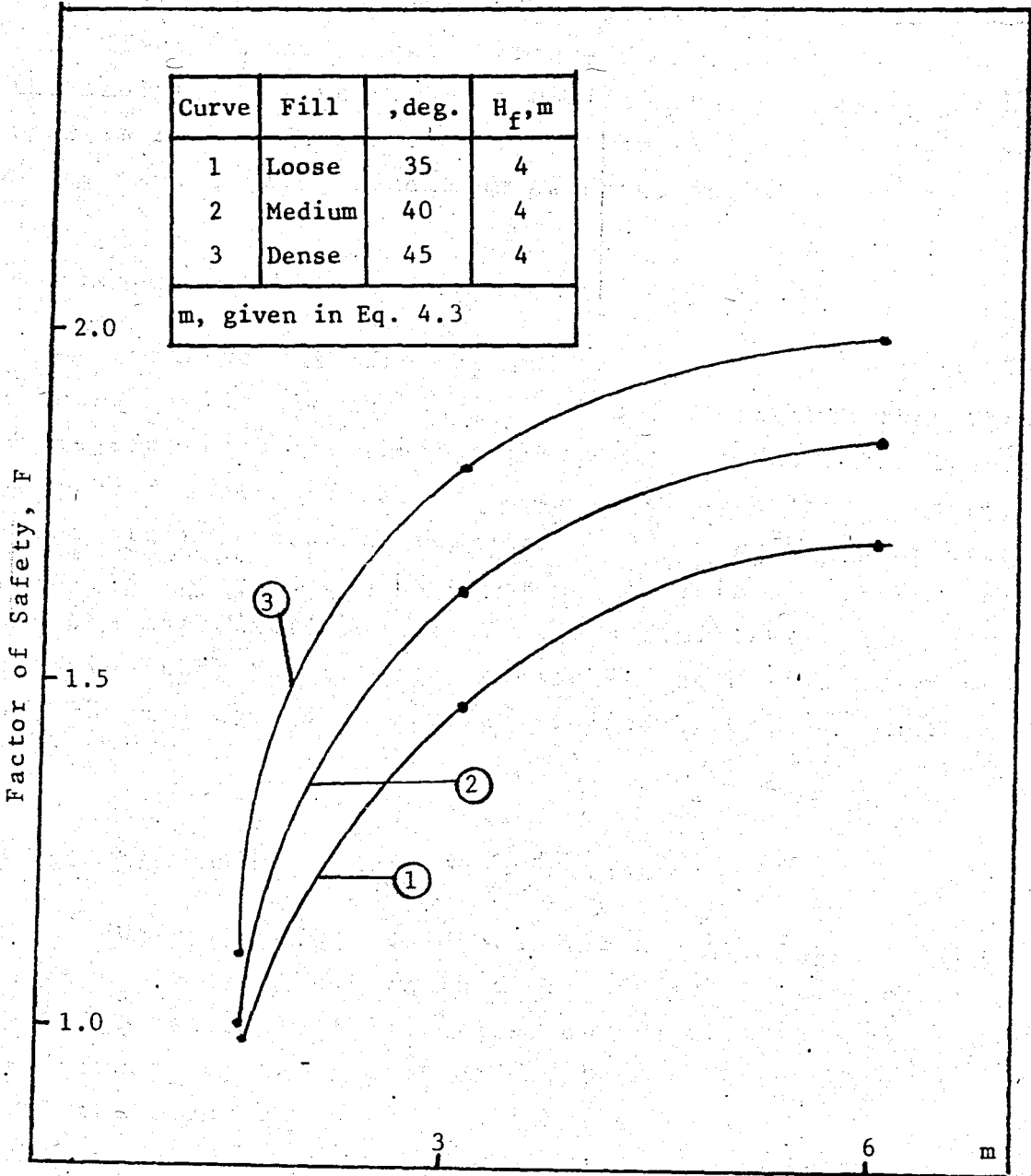

Fig. 4.13. Variation of the factor of safety with respect to slope of the subsoil shear strength, m , by Bishop's Modified Method

A. Effect of the Fill Shear Strength

When the Fig's 4.12 and 4.13 are examined it is observed that for a fixed unit weight of the fill material, the increase of the internal friction angle of the fill is accompanied by an increase in the factor of safety. Since the effect of the slice interface forces are considered in the analysis of the Bishop's Modified Method, this method results higher factor of safety than the Ordinary Method of Slices for a given condition as shown in Table 4.8.

B. Critical Circle Trajectories

When we examine the trajectories of the critical circles (Table A16 through Table A30) we observe that the increasing value of the shear strength of the subsoil decreases the deepness of the critical circles. When the constant shear strength case is replaced by the varying shear strength case, it is observed that the critical circles go less deeper and the associated factor of safety diminishes. Again it is observed that the circles studied by the Modified Bishop's Method go deeper than circles studied by Ordinary Method of Slices.

C. Effect of Subsoil Shear Strength

When the Fig's 4.12 and 4.13 are examined it is observed that for the whole range of the internal friction angle of the fill material, the increase of the m is accompanied by an increase of the factor of safety; result which conforms with the constant shear strength case.

When we consider the slope of the shear strength in lieu of the constant shear strength, we observe that, for the same instance, constant cohesion intercept gives higher factor of safety and the associated critical circle go much deeper than the circle associated to variable cohesion intercept case. Those results can be observed by comparing the

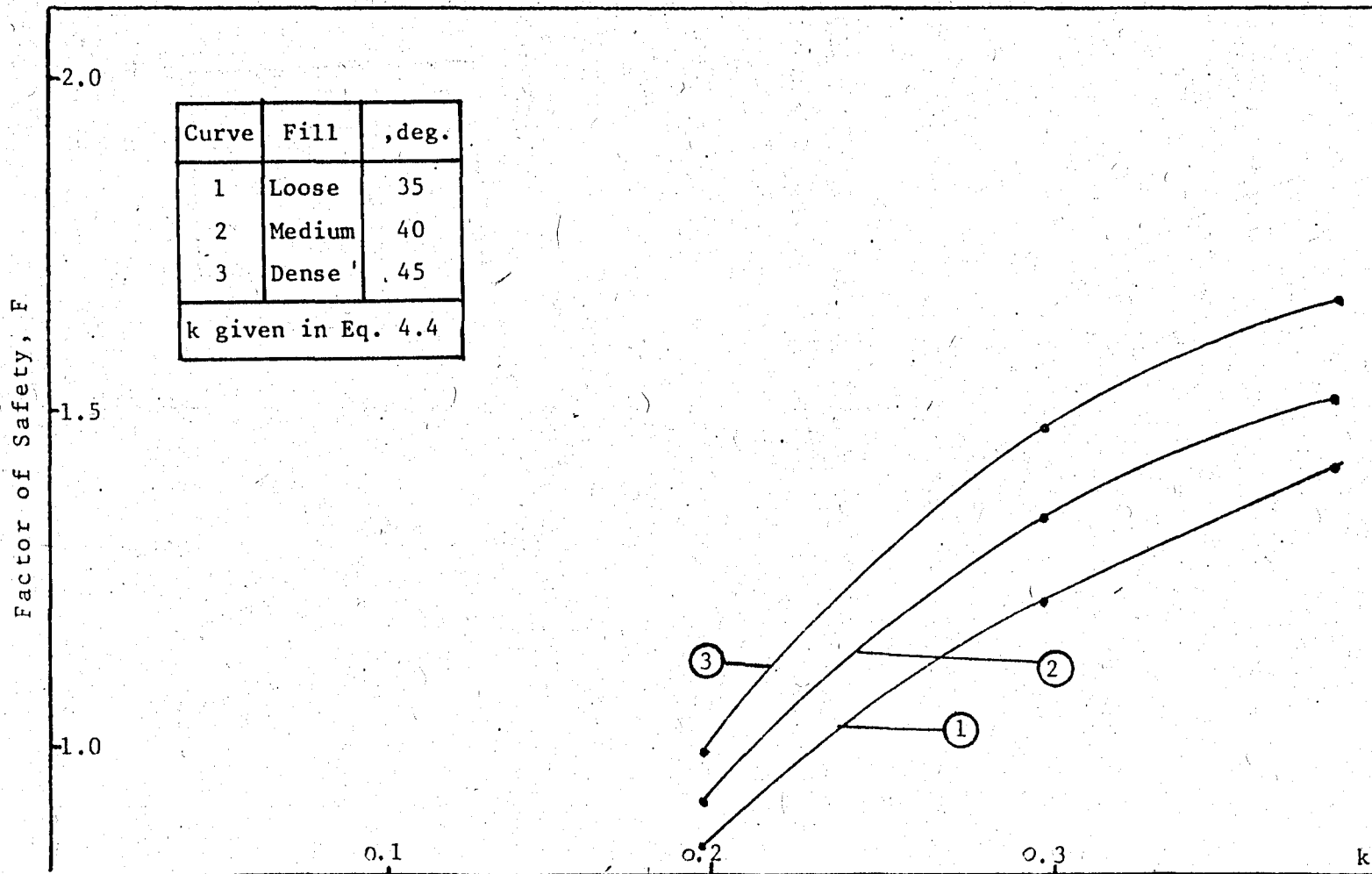

Fig. 4.14. Variation of the factor of safety with respect to dimensionless parameter, k, by Ordinary Method of Slices

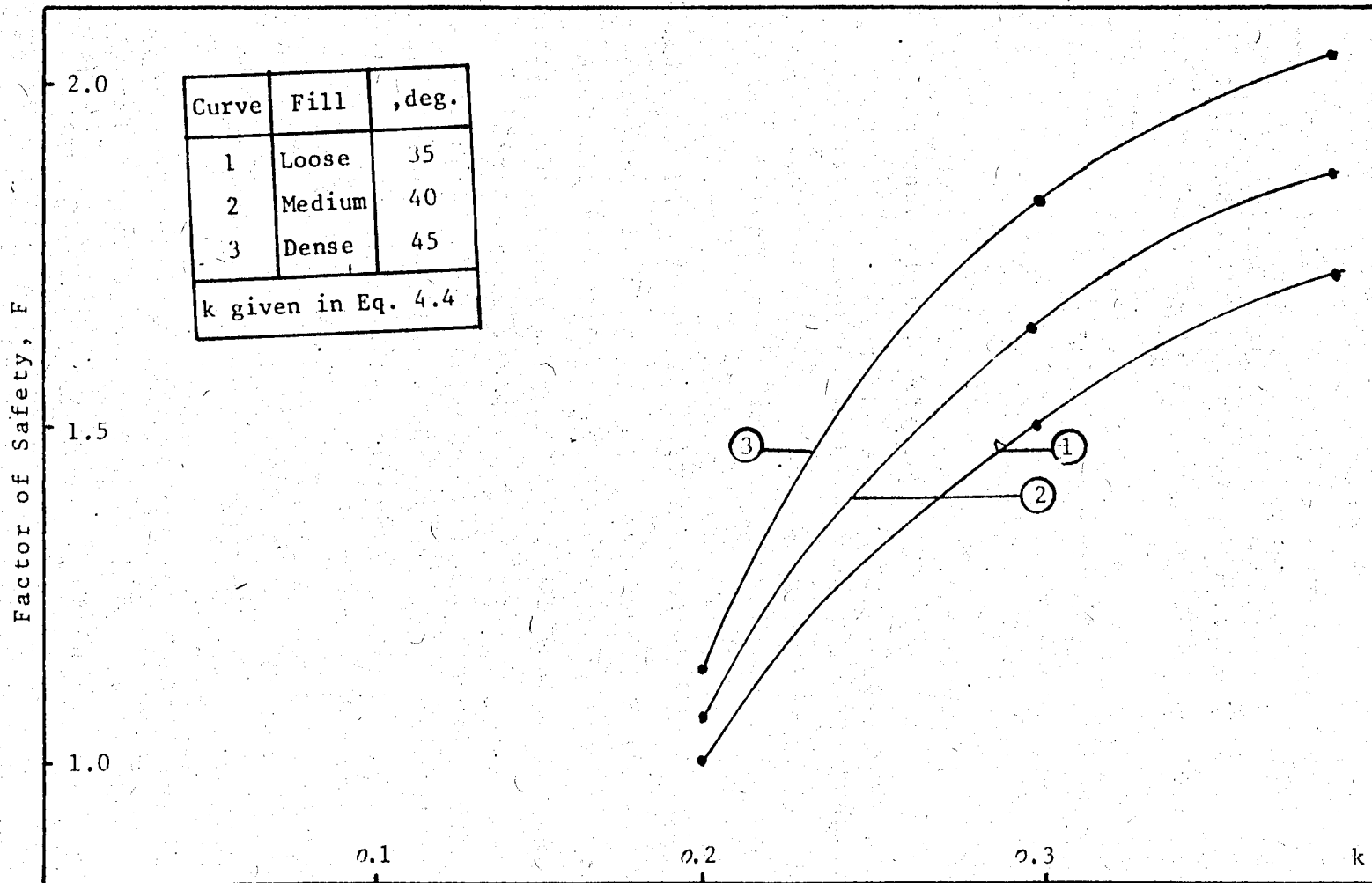

Fig. 4.15. Variation of the factor of safety with respect to dimensionless parameter, k , by Bishop's Modified Method

Tables A1 through A3 and A16 through A21 to Tables A22 through A30.

D. Normalization of the Results

The variation of the factor of safety with respect to the rate of the subsoil shear strength, m , is plotted in Fig's 4.12 and 4.13. It is also intended to obtain the variation of the factor of safety with respect to a dimensionless parameter, k ,

$$k = \frac{mh}{\gamma_f H_f} \quad (4.4)$$

where

- m : rate of the subsoil shear strength
- h : depth within the subsoil from which the critical circle passes for the varying shear strength
- γ_f : Unit weight of the fill
- H_f : Height of the fill

in order to have a preliminary idea about the factor of safety when the subsoil shear strength are known (Fig's 4.14 and 4.15). Although the Fig's 4.14 and 4.15 have limited use, they indicates that the factor of safety is increased when the critical circle goes deep, when the rate of increase of the shear strength of the subsoil is higher, and the increase of the unit weight and the height of the fill material have diminishing effect on the factor of safety.

4.5. CONCLUSIONS

For the example studied the values of the factor of safety calculated by the Modified Bishop procedure are in general 11 % higher than the value obtained by the Ordinary Method of Slices. For homogenous slopes it may be noted that the maximum difference that can be found between the factor

of safety by these two procedures of analysis is only about 7 %, and thus the larger influence of the normal stress distributions for analyses of inhomogeneous soil profiles may be seen.

When the results of the Chapter are examined it is observed that for a fixed subsoil cohesion intercept and for a fixed fill unit weight, the factor of safety increases with an increasing value of the internal friction angle and decreases with an increasing value of the fill height as expected. But if the unit weight of the fill material is increased with its internal friction angle (which is more realistic) it is constated that the increase of the internal friction angle is not accompagned by an increase of the corresponding factor of safety.

For a fixed fill layer height it is observed that the factor of safety is directly proportional to the subsoil shear strength and it increases with an increasing value of the internal friction angle of the fill material.

A chart giving the variation of the factor of safety with respect to subsoil shear strength; unit weight, internal friction angle and the height of the fill material is generated in order to obtain directly the value of the factor of safety when subsoil shear strength is known.

When the linearly varying shear strength of the subsoil with depht is examined it is observed that the critical circles pass from the higher layers when compared to the constant shear strength cases, but result lower factor of safety values.

When the stability numbers are back calculated used in studying the example by use of the bearing capacity failure criteria; it is concluded that the Modified Bishop's method is more reliable than the Ordinary Method of Slices with a mean values of the stability number of 5.331.

5. SUMMARY AND CONCLUSIONS

The solutions of the slope stability problems by stability charts are discussed in Chapter 2. For simple homogeneous slopes and simple slope profiles they provide quite practical tool for immediate applications. These charts could also be used for non-homogeneous soil conditions using the average shear strength parameters as described. Most of these charts are generated using the procedures satisfying overall moment equilibrium and assuming circular shear surfaces. In addition charts using friction circle, the logarithmic spiral procedures are also provided. In Chapter 3 the procedures of detailed stability analysis in which the soil mass is divided vertically into a number of slices are discussed. The similarities and differences in the various procedures is examined in terms of the conditions of equilibrium which they satisfy and the assumptions they employ to achieve statical determinacy. Any procedure satisfying an equilibrium condition for each slice automatically satisfies that same condition for the entire mass bounded by the shear surface.

The accuracy of the various procedures of analysis is not necessarily related to the number of equilibrium conditions satisfied. For example the Modified Bishop Method solution, which satisfies only $n+1$ equilibrium conditions, may yield a better value for the factor of safety than a force equilibrium procedure using the same side force assumption and satisfying $2n$ conditions of equilibrium.

From the standpoint of mechanics it is desirable to use a procedure satisfying equilibrium as completely as is reasonably justified with respect to both accuracy and effort. However for methods which do not satisfy all conditions of equilibrium it is shown by Wright (1969) that the condition of moment equilibrium should be considered of somewhat greater importance for $\phi=0$ soil than force equilibrium. For this reason the Ordinary Method of Slices and Bishop's Modified Method are used in the calculations in Chapter 4.

For the example studied in Chapter 4, the values of the factor of safety calculated by the Modified Bishop's procedure are in general 11% higher than the value obtained by the Ordinary Method of Slices. For homogeneous slopes it may be noted that the maximum difference that can be found between the factor of safety by these two procedures of analysis is only about 7%, and thus the larger influence of the normal stress distributions for analysis of inhomogeneous soil profiles may be seen.

When the results of the Chapter are 4 examined, it is observed that for a fixed subsoil cohesion intercept and for a fixed fill unit weight, the factor of safety increases with an increasing value of the internal friction angle and decreases with an increasing value of the fill height as expected. But if the unit weight of the fill material is increased with its internal friction angle (which is more realistic) it is constated that the increase of the internal friction angle is not accompagned by an increase of the

corresponding factor of safety.

For a fixed fill layer height it is observed that the factor of safety is directly proportional to the subsoil shear strength and it increases with an increasing value of the internal friction angle of the fill material.

A chart giving the variation of the factor of safety with respect to subsoil shear strength; unit weight, internal friction angle and the height of the fill material is generated in order to obtain directly the value of the factor of safety when subsoil shear strength is known.

When the linearly varying shear strength of the subsoil with depth is examined it is observed that the critical circles pass from the higher layers when compared to the constant shear strength cases, but result lower factor of safety values.

When the stability numbers are back calculated used in studying the example by use of the bearing capacity failure criteria; it is concluded that the Modified Bishop's method is more reliable than the Ordinary Method of Slices with a mean values of the stability number of 5.331.

REFERENCES

Bell, James M., "General Slope Stability Analysis", Journal of the Soil Mechanics and Foundation Division, ASCE, Vol.94, No.5MG, Nov.1968, pp 1253-1270.

Bishop, A.W., "The use of the Slip Circle in the Stability Analysis of Slopes", Geotechniques, Vol.5, No.1, Mar., 1955, pp.7-17.

Bishop, A.W. and Morgenstern, N., "Stability Coefficients for Earth Slopes", Geotechnique, Vol.10, No.4, Dec., 1960, pp.129-150.

Bjerrum, L. and Flodin, N., "The Development of soil Mechanics in Sweden, 1900-1925", Geotechnique, Vol.10, No.1, March, 1969, pp.1-18.

Culmann, K., Die graphische Statik. Zurich, 1866.

Duncan, J.M. and Buchignani, A.L., An Engineering Manual for Slope Stability Studies, Department of Civil Engineering Institute of Transportation and Traffic Engineering, University of California, Berkeley, March, 1975.

Fellenius, W., Discussion to a paper by P.G.Hörnell, "Kaj-och-jordrasen i Göteborg", ("The quay-and landslides in Gothenburg"), Teknisk Tidskrif, V.V., Vol.46, No.15; Vol.48, No.2, 1918.

Fellenius, W., "Erdstatische Berechnungen", Berlin (W.Ernst), 1927.

Fellenius, W., "Calculation of the Stability of Earth Dams", Transactions Second Congress on Large Dams, International Commission on Large Dams of the World Power Conference, Vol.4, Washington, 1936, pp.445-459.

Hunter, J.H. and Schuster, R.L., "Stability of Simple Cutting in Normally Consolidated Clay", Geotechnique, Vol.13, No.3, September, 1968, pp.372-378.

Janbu, N., Bjerrum, L. and Kjaernstli, B., "Veiledning ved losning av fundamentergsoppgaver-2. Stabilitetsberegning for fyllinger, skjaeringer og naturlige skraninger", (Soil Mechanics Applied to Some Engineering Problems-Chapter 2. Stability Calculations for Embankments), Institute, Oslo, 1956, pp.17-26.

Janbu, N., "Earth Pressure and Bearing Capacity Calculations by Generalized Procedure of Slices", Proceedings of the Fourth International Conference on Soil Mechanics and Foundation Engineering, Vol.2, London, 1957, pp.207-212.

Janbu, N., Discussion of paper by Bell, "Dimensionless Parameters for Homogeneous Earth Slopes", Journal of the Soil Mechanics and Foundations Division, ASCE, Vol.93, No.SMG, Nov., 1967, pp.367-374.

Janbu, N., "Slope Stability Computations", Soil Mechanics and Foundation Engineering Report, The Technical University of Norway, Trondheim, 1968.

Lowe, J. and Karafiath, L., "Stability of Earth Dams Upon Drawdown", Proceeding of First Pan American Conference on Soil Mechanics and Foundation Engineering, Mexico City, Vol.2, 1960, pp.537-552.

Morgenstern, N.R. and Price, V.E., "The Analysis of the Stability of General Slip Surfaces", Geotechnique, Vol.15, No.1, Mar., 1965, pp.79-93.

Morgenstern, N.R. and Price, V.E., "A numerical Method for Solving the Equations of Stability of General Slip Surfaces", The Computer Journal, Great Britain, Vol.9, No.4, Feb., 1967, pp.388-393.

Nonveiller, E., "The Stability Analysis of Slopes with a Slip Surface of General Shape", Proceedings of the Sixth International Conference on Soil Mechanics and Foundation Engineering, Vol. 2, Montreal, 1965, pp.522-525.

Petterson, Knut E., "The Early History of Circular Sliding Surfaces", Geotechnique, Vol.5, No.4, Dec.1955, pp.275-296.

Raedschelders, H., "Improvement of the Method of Calculation of the Equilibrium along a Sliding Circles", Proceedings of the Second International Conference on Soil Mechanics and Foundation Engineering, Vol.1, Rotterdam, 1948, pp.68-72.

Spencer, E., "A Method of Analysis of the Stability of Embankments Assuming Parallel Inter-Slice Forces", Geotechnique, Vol.17, No.1, Mar., 1967, pp.11-26.

Taylor, D.W., "Stability of Slopes", Fundamentals of Soil Mechanics, John Wiley and Sons., Inc., New York, 1948, pp.406-479.

U.S. Army Corps of Engineers, "Manuals-Corps of Engineers: Engineering and Design, Stability of Earth and Rockfill Dams", Revision Draft, Feb., 1968.

Wright, S.G., "A study of Slope Stability and the Undrained Shear Strength of Clay Shales", Ph.D.Thesis, Department of Civil Engineering University of California, Berkeley, 1969.

APPENDIX

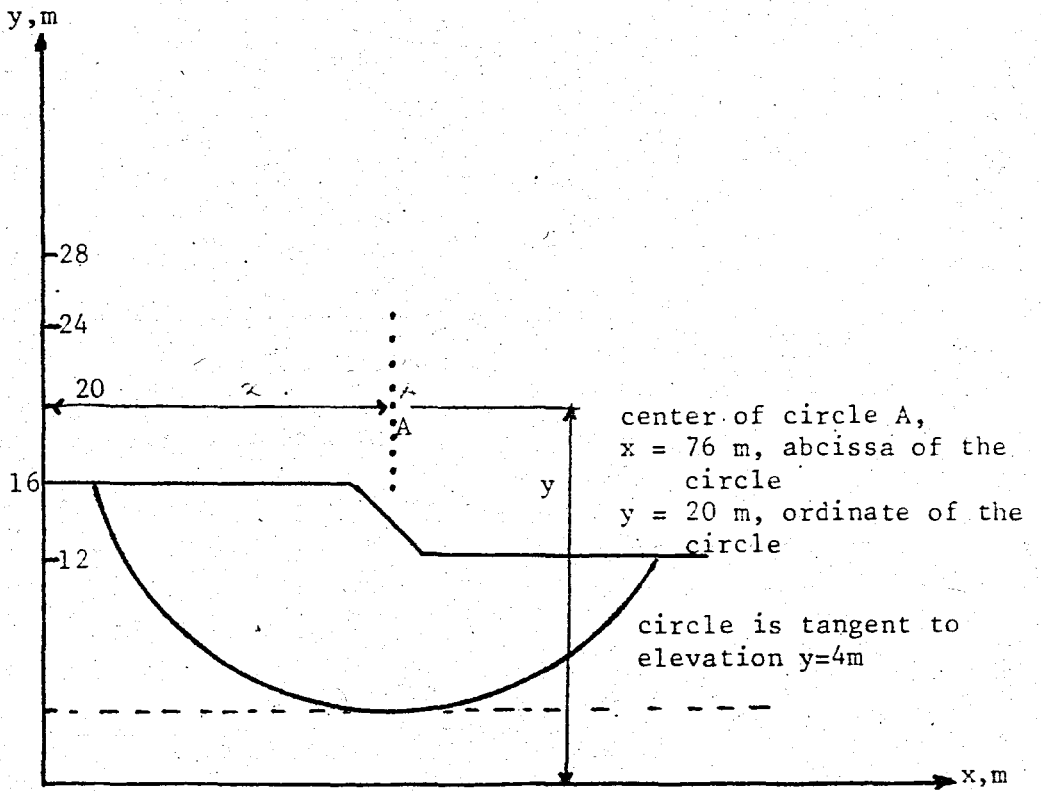

Fig. A.1. Geometry and circle centers considered for $H_f = 4$ m

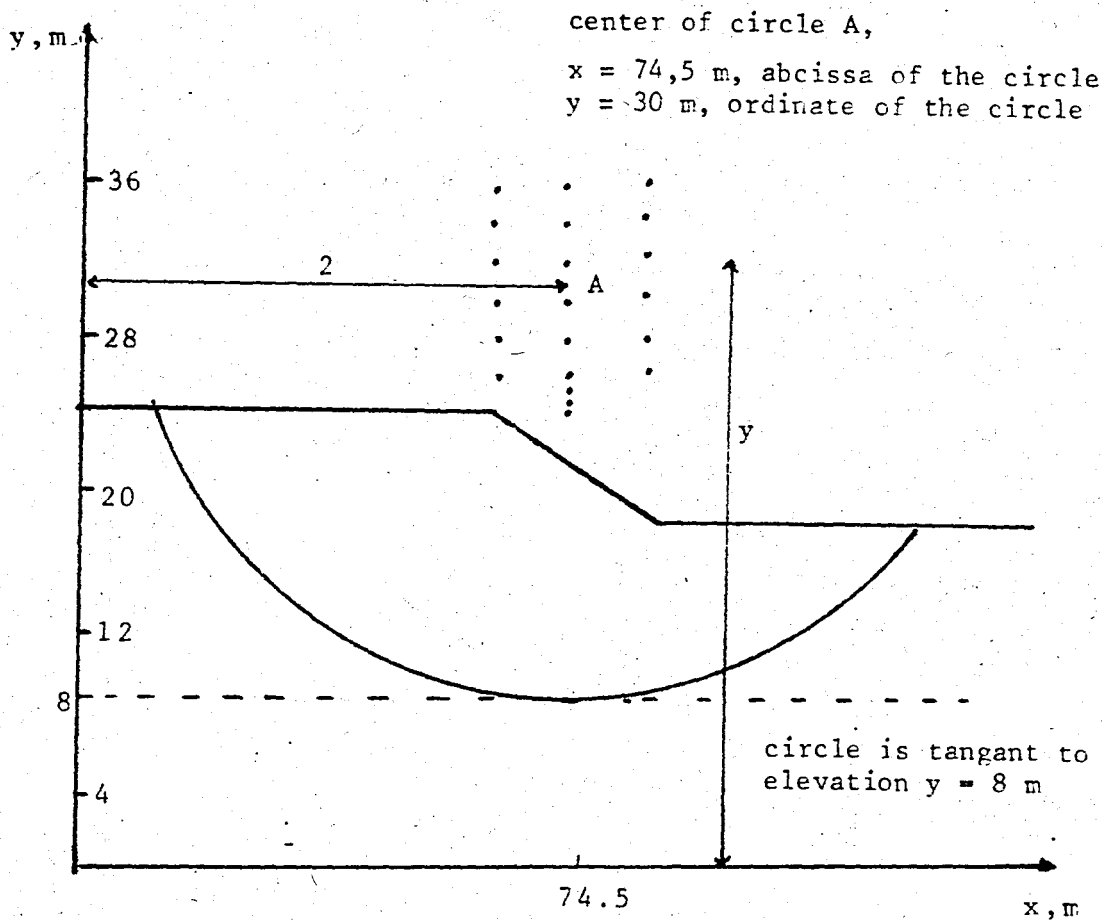

Fig.A.2. Geometry and circle centers considered for $H_f = 6$ m

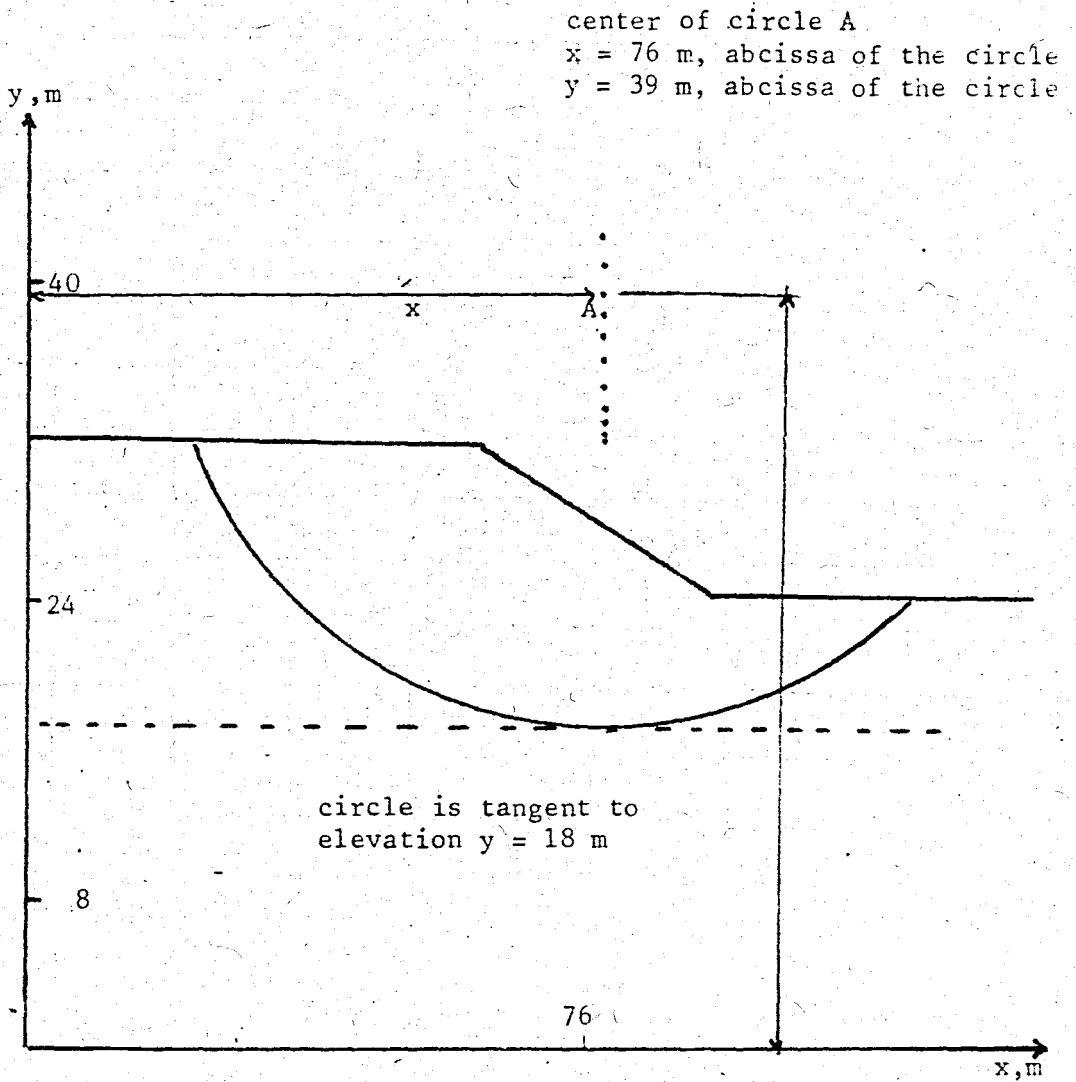

Fig. A.3. Geometry and circle centers considered for $H_f = 8$ m

Table A30- C = 6 t/m³ $\phi_{fill} = 45^\circ$ (Run 30)

Circle centers y(m) (1)	Ordinate of Lowest Point on the Circle (m)							
	y=10		y=11		y=11,5		y=12	
	OMS	BM	OMS	BM	OMS	BM	OMS	BM
25	5.299	5.551	3.193	3.384	2.508	2.622	3.567	3.747
24	5.178	5.441	3.097	3.299	2.421	2.543	3.443	3.635
23	5.056	5.332	3.000	3.214	2.331	2.463	3.314	3.521
22	4.936	5.227	2.901	3.129	2.240	2.384	3.182	3.406
21	4.819	5.127	2.801	3.047	2.145	2.303	3.045	3.292
20	4.710	5.037	2.701	2.969	2.047	2.224	2.905	3.181
19	4.612	4.964	2.605	2.900	1.948	2.150	2.762	3.078
18	4.535	4.917	2.517	2.847	1.847	2.087	2.622	2.993
17	4.501	4.921	2.449	2.828	1.751	2.046	2.497	2.950
16	4.552	5.016	2.433	2.881	1.677	2.060	2.428	3.046

ORDINARY METHOD OF SLICES, MINIMUM FACTOR OF SAFETY: 1.677

BISHOPS MODIFIED METHOD, MINIMUM FACTOR OF SAFETY : 2.046

(1) x = 76 m

Table A29- C = 4.50 t/m³, $\phi_{fill} = 45^\circ$ (Run29)

Circle centers y(m) (1)	Ordinate of Lowest Point on the Circle (m)							
	y=10		y=11		y=11,5		y=12	
	OMS	BM	OMS	BM	OMS	BM	OMS	BM
25	2.668	2.821	4.127	4.350	2.290	2.375	3.567	3.747
24	2.584	2.746	4.028	4.261	2.208	2.300	3.443	3.635
23	2.497	2.670	3.928	4.173	2.124	2.223	3.314	3.521
22	2.409	2.595	3.829	4.087	2.038	2.147	3.182	3.406
21	2.320	2.520	3.732	4.006	1.947	2.069	3.045	3.292
20	2.320	2.450	3.640	3.932	1.853	1.992	2.905	3.181
19	2.141	2.385	3.555	3.869	1.757	1.918	2.762	3.078
18	2.058	2.333	3.486	3.827	1.658	1.853	2.622	2.993
17	1.987	2.306	3.447	3.821	1.561	1.807	2.497	2.950
16	1.955	2.334	3.472	3.883	1.479	1.809	2.428	3.016

ORDINARY METHOD OF SLICES, MINIMUM FACTOR OF SAFETY: 1.479

BISHOPS MODIFIED METHOD, MINIMUM FACTOR OF SAFETY : 1.807

(1) x = 76 m

Table A28- C = 1.50 t/m³, $\phi_{fill} = 45^\circ$ (Run28)

Circle centers y (m) (1)	Ordinate of Lowest Point on the Circle (m)									
	y=8		y=9		y=10		y=11		y=12	
	OMS	BM	OMS	BM	OMS	BM	OMS	BM	OMS	BM
25	2.726	2.873	2.209	2.336	1.782	1.865	1.618	1.628	3.567	3.747
24	2.675	2.827	2.156	2.290	1.728	1.817	1.557	1.570	3.443	3.635
23	2.624	2.783	2.104	2.243	1.672	1.768	1.493	1.510	3.314	3.521
22	2.575	2.741	2.051	2.199	1.615	1.719	1.427	1.449	3.182	3.406
21	2.529	2.702	2.000	2.156	1.558	1.670	1.359	1.388	3.045	3.292
20	2.487	2.668	1.950	2.116	1.500	1.623	1.288	1.325	2.905	3.181
19	2.450	2.641	1.904	2.081	1.443	1.580	1.214	1.264	2.762	3.078
18	2.425	2.625	1.865	2.055	1.388	1.541	1.139	1.206	2.622	2.993
17	2.417	2.625	1.839	2.042	1.341	1.514	1.064	1.156	2.497	2.950
16	2.440	2.653	1.838	2.053	1.311	1.506	0.998	1.126	2.428	3.016

ORDINARY METHOD OF SLICES, MINIMUM FACTOR OF SAFETY : .998

BISHOPS MODIFIED METHOD, MINIMUM FACTOR OF SAFETY : 1.126

(1) x = 76 m

Table A27- $C = 6 \text{ t/m}^3$, $\phi_{\text{fill}} = 40^\circ$ (Run27)

Circle centers y(m) (1)	Ordinate of Lowest Point on the Circle (m)							
	y=10		y=11		y=11,5		y=12	
	OMS	BM	OMS	BM	OMS	BM	OMS	BM
25	5.201	5.425	3.017	3.197	2.244	2.356	2.993	3.144
24	5.085	5.319	2.929	3.118	2.168	2.287	2.889	3.050
23	4.969	5.214	2.840	3.040	2.090	2.217	2.781	2.954
22	4.854	5.113	2.750	2.963	2.010	2.149	2.670	2.858
21	4.744	5.017	2.659	2.888	1.927	2.079	2.555	2.762
20	4.640	4.932	2.570	2.818	1.843	2.012	2.437	2.669
19	4.549	4.863	2.484	2.757	1.757	1.949	2.318	2.583
18	4.480	4.821	2.408	2.712	1.671	1.896	2.200	2.511
17	4.455	4.829	2.352	2.701	1.591	1.866	2.095	2.475
16	4.515	4.929	2.349	2.760	1.534	1.886	2.037	2.531

ORDINARY METHOD OF SLICES, MINIMUM FACTOR OF SAFETY: 1.534

BISHOPS MODIFIED METHOD, MINIMUM FACTOR OF SAFETY : 1.866

(1) x = 76 m

Table A26- C = 4.50 t/m³, $\phi_{fill} = 40^\circ$ (Run26)

Circle centers y(m) (1)	Ordinate of Lowest Point on the Circle (m)							
	y=10		y=11		y=11,5		y=12	
	OMS	BM	OMS	BM	OMS	BM	OMS	BM
25	4.029	4.231	2.492	2.640	2.027	2.113	2.993	3.144
24	3.935	4.146	2.416	2.572	1.956	2.047	2.889	3.050
23	3.841	4.062	2.338	2.504	1.882	1.982	2.781	2.954
22	3.747	3.981	2.259	2.437	1.808	1.917	2.670	2.858
21	3.656	3.904	2.179	2.370	1.729	1.850	2.555	2.762
20	3.571	3.834	2.099	2.308	1.649	1.784	2.437	2.669
19	3.493	3.777	2.021	2.251	1.566	1.722	2.318	2.583
18	3.431	3.739	1.948	2.207	1.482	1.669	2.200	2.511
17	3.401	3.739	1.890	2.189	1.401	1.633	2.095	2.475
16	3.435	3.807	1.871	2.225	1.336	1.640	2.037	2.531

ORDINARY METHOD OF SLICES, MINIMUM FACTOR OF SAFETY: 1.336

BISHOPS MODIFIED METHOD, MINIMUM FACTOR OF SAFETY : 1.633

(1) x = 76 m

Table A25- C = 1.50 t/m², $\phi_{fill} = 40^\circ$ (Run25)

Circle centers y(m) (1)	Ordinate of Lowest Point on the Circle (m)									
	y=8		y=9		y=10		y=11		y=12	
	OMS	BM	OMS	BM	OMS	BM	OMS	BM	OMS	BM
25	2.682	2.819	2.146	2.270	1.684	1.775	1.442	1.468	2.993	3.144
24	2.634	2.776	2.097	2.226	1.635	1.731	1.389	1.418	2.889	3.050
23	2.586	2.734	2.048	2.184	1.584	1.687	1.334	1.367	2.781	2.954
22	2.540	2.694	2.000	2.142	1.533	1.643	1.277	1.316	2.670	2.858
21	2.497	2.658	1.952	2.103	1.482	1.600	1.218	1.263	2.555	2.762
20	2.458	2.627	1.907	2.067	1.431	1.559	1.156	1.211	2.437	2.669
19	2.425	2.603	1.866	2.036	1.381	1.521	1.093	1.160	2.318	2.583
18	2.403	2.590	1.832	2.014	1.334	1.489	1.030	1.112	2.200	2.511
17	2.400	2.594	1.812	2.006	1.295	1.468	.967	1.073	2.095	2.475
16	2.428	2.626	1.818	2.022	1.274	1.467	(.914)	(1.053)	2.037	2.531

ORDINARY METHOD OF SLICES, MINIMUM FACTOR OF SAFETY : .914

BISHOPS MODIFIED METHOD, MINIMUM FACTOR OF SAFETY : 1.053

(1) x = 76 m

Table A24- $C_{\text{subsoil}} = 6 \text{ t/m}^3$, $\phi_{\text{fill}} = 35^\circ$ (Run24)

Circle centers y(m) (1)	Ordinate of Lowest Point on the Circle (m)							
	y=10		y=11		y=11,5		y=12	
	OMS	BM	OMS	BM	OMS	BM	OMS	BM
25	5.116	5.314	2.865	3.031	2.017	2.124	2.498	2.624
24	5.004	5.210	2.784	2.958	1.950	2.064	2.411	2.545
23	4.893	5.109	2.703	2.886	1.881	2.004	2.321	2.465
22	4.784	5.011	2.620	2.815	1.812	1.944	2.228	2.385
21	4.678	4.919	2.537	2.747	1.739	1.884	2.132	2.305
20	4.581	4.837	2.457	2.684	1.666	1.826	2.034	2.227
19	4.496	4.771	2.380	2.629	1.592	1.773	1.934	2.155
18	4.433	4.733	2.313	2.591	1.519	1.729	1.836	2.095
17	4.415	4.744	2.268	2.585	1.453	1.706	1.748	2.066
16	4.483	4.849	2.277	2.649	1.411	1.731	1.700	2.122

ORDINARY METHOD OF SLICES, MINIMUM FACTOR OF SAFETY: 1.411

BISHOPS MODIFIED METHOD, MINIMUM FACTOR OF SAFETY : 1.706

(1) x = 76 m

Table A23- $C_{\text{subsoil}} = 4.50 \text{ t/m}^3$, $\phi_{\text{fill}} = 35^\circ$ (Run 23)

Circle centers y(m) (1)	Ordinate of Lowest Point on the Circle (m)							
	y=10		y=11		y=11,5		y=12	
	OMS	BM	OMS	BM	OMS	BM	OMS	BM
25	3.944	4.125	2.340	2.481	1.799	1.884	2.498	2.624
24	3.854	4.043	2.271	2.419	1.737	1.828	2.411	2.545
23	3.765	3.963	2.200	2.357	1.674	1.771	2.321	2.465
22	3.677	3.885	2.129	2.296	1.609	1.715	2.228	2.385
21	3.591	3.812	2.057	2.236	1.541	1.658	2.132	2.305
20	3.511	3.746	1.985	2.181	1.472	1.603	2.034	2.227
19	3.439	3.692	1.916	2.131	1.402	1.551	1.934	2.155
18	3.384	3.659	1.854	2.094	1.331	1.506	1.836	2.095
17	3.361	3.663	1.806	2.082	1.264	1.479	1.748	2.066
16	3.403	3.735	1.799	2.124	1.213	1.492	1.700	2.112

ORDINARY METHOD OF SLICES, MINIMUM FACTOR OF SAFETY: 1.213

BISHOPS MODIFIED METHOD, MINIMUM FACTOR OF SAFETY : 1.479

(1) x = 76 m

Table A22- C = 1.50 t/m³, $\phi_{fill} = 35^\circ$ (Run22)

Circle centers y(m) (1)	Ordinate of Lowest Point on the Circle (m)									
	y=8		y=9		y=10		y=11		y=12	
	OMS	BM	OMS	BM	OMS	BM	OMS	BM	OMS	BM
25	2.644	2.770	2.091	2.209	1.599	1.692	1.290	1.328	2.498	2.624
24	2.598	2.728	2.045	2.168	1.554	1.653	1.244	1.285	2.411	2.545
23	2.552	2.688	2.000	2.128	1.509	1.613	1.196	1.242	2.321	2.465
22	2.509	2.651	1.955	2.090	1.463	1.573	1.147	1.197	2.228	2.385
21	2.469	2.616	1.911	2.053	1.417	1.535	1.096	1.153	2.132	2.305
20	2.433	2.588	1.870	2.020	1.371	1.498	1.043	1.109	2.034	2.227
19	2.404	2.566	1.834	1.993	1.327	1.465	.989	1.066	1.934	2.155
18	2.385	2.556	1.804	1.974	1.286	1.438	.935	1.027	1.836	2.095
17	2.385	2.564	1.789	1.970	1.255	1.423	.883	.997	1.748	2.066
16	2.417	2.600	1.800	1.991	1.242	1.428	.842	.986	1.700	2.112

ORDINARY METHOD OF SLICES, MINIMUM FACTOR OF SAFETY : .842

BISHOPS MODIFIED METHOD, MINIMUM FACTOR OF SAFETY : .986

(1) x = 76 m

Table A21- $C = 6 \text{ t/m}^2$, $\phi_{\text{fill}} = 45^\circ$ (Run21)

Circle center y(m) (1)	Ordinate of Lowest Point on the Circle (m)											
	y=0		y=2		y=4		y=6		y=8		y=10	
	OMS	BM	OMS	BM	OMS	BM	OMS	BM	OMS	BM	OMS	BM
25	3.896	4.000	3.886	4.004	3.889	4.023	3.916	4.072	3.988	4.173	4.150	4.374
24	3.886	3.992	3.868	3.987	3.860	3.997	3.870	4.031	3.921	4.113	4.051	4.286
23	3.880	3.988	3.853	3.975	3.833	3.975	3.828	3.994	3.856	4.056	3.953	4.199
22	3.880	3.989	3.844	3.969	3.812	3.957	3.791	3.962	3.795	4.002	3.855	4.114
21	54.49	57.70	3.841	3.968	3.797	3.946	3.759	3.936	3.738	3.955	3.760	4.034
20	3.899	4.010	3.847	3.976	3.791	3.943	3.735	3.918	3.688	3.915	3.669	3.962
19	3.924	4.034	3.865	3.995	3.797	3.952	3.724	3.913	3.649	3.888	3.587	3.902
18	62.53	66.92	3.898	4.028	3.819	3.976	3.730	3.925	3.628	3.879	3.521	3.863
17	-109.5	-118.3	46.45	50.30	49.57	54.27	3.762	3.961	3.636	3.900	3.486	3.862
16	-144.8	-157.3	-133.7	-146.7	40.65	44.72	3.837	4.032	3.696	3.966	3.518	3.932

ORDINARY METHOD OF SLICES, MINIMUM FACTOR OF SAFETY : 3.486

BISHOPS MODIFIED METHOD, MINIMUM FACTOR OF SAFETY : 3.862

(1) $x = 76 \text{ m}$

Table A20- $C = 6 \text{ t/m}^2$, $\phi_{\text{fill}} = 40^\circ$ (Run20)

Circle centers y(m) (1)	Ordinate of Lowest Point on the Circle (m)											
	y=0		y=2		y=4		y=6		y=8		y=10	
	OMS	BM	OMS	BM	OMS	BM	OMS	BM	OMS	BM	OMS	BM
25	3.888	3.982	3.875	3.981	3.873	3.994	3.891	4.031	3.944	4.111	4.052	4.255
24	3.879	3.975	3.858	3.966	3.845	3.969	3.847	3.992	3.880	4.053	3.959	4.171
23	3.874	3.971	3.844	3.955	3.820	3.948	3.807	3.957	3.818	3.998	3.865	4.088
22	3.874	3.973	3.836	3.949	3.800	3.931	3.771	3.926	3.759	3.947	3.773	4.008
21	54.41	57.18	3.834	3.950	3.786	3.921	3.741	3.901	3.705	3.901	3.684	3.932
20	3.894	3.996	3.841	3.959	3.782	3.920	3.720	3.886	3.659	3.865	3.599	3.864
19	3.920	4.022	3.860	3.979	3.789	3.930	3.711	3.883	3.624	3.840	3.524	3.809
18	62.48	66.19	3.894	4.013	3.813	3.956	3.719	3.896	3.607	3.835	3.466	3.775
17	-109.5	-116.8	46.41	49.68	49.50	53.48	3.754	3.935	3.619	3.859	3.440	3.779
16	-144.7	-155.1	-133.6	-144.5	40.60	44.08	3.831	4.010	3.683	3.930	3.481	3.855

ORDINARY METHOD OF SLICES, MINIMUM FACTOR OF SAFETY : 3.440

BISHOPS MODIFIED METHOD, MINIMUM FACTOR OF SAFETY : 3.775

(1) $x = 76 \text{ m}$

Table A19- $c = 6 \text{ t/m}^2$, $\phi_{\text{fill}} = 35^\circ$ (Run19)

Circle centers y(m) (1)	Ordinate of Lowest Point on the Circle (m)											
	y 0		y 2		y 4		y 6		y 8		y 10	
	OMS	BM	OMS	BM	OMS	BM	OMS	BM	OMS	BM	OMS	BM
25	3.881	3.965	3.866	3.960	3.859	3.967	3.869	3.994	3.906	4.054	3.967	4.148
24	3.873	3.958	3.849	3.946	3.832	3.943	3.827	3.956	3.844	3.998	3.878	4.067
23	3.868	3.956	3.836	3.935	3.808	3.922	3.788	3.922	3.784	3.945	3.790	3.988
22	3.869	3.958	3.829	3.930	3.790	3.907	3.754	3.892	3.728	3.895	3.703	3.912
21	54.33	56.66	3.828	3.931	3.777	3.897	3.726	3.869	3.677	3.852	3.619	3.840
20	3.891	3.982	3.836	3.941	3.774	3.897	3.706	3.855	3.634	3.817	3.540	3.776
19	3.917	4.009	3.856	3.962	3.783	3.909	3.700	3.853	3.602	3.795	3.471	3.724
18	62.43	65.56	3.890	3.998	3.808	3.937	3.710	3.869	3.588	3.792	3.419	3.694
17	-109.4	-115.5	46.37	49.13	49.43	52.79	3.747	3.910	3.604	3.819	3.400	3.700
16	-144.7	-153.3	-133.6	-142.5	40.57	43.11	3.826	3.988	3.672	3.894	3.449	3.784

ORDINARY METHOD OF SLICES, MINIMUM FACTOR OF SAFETY : 3.400

BISHOPS MODIFIED METHOD, MINIMUM FACTOR OF SAFETY : 3.694

(1) $x = 76 \text{ m}$

Table A18- $C = 4.5 \text{ t/m}^2$, $\phi_{\text{fill}} = 45^\circ$ (Run18)

Circle centers y(m) (1)	Ordinate of Lowest Point on the Circle (m)											
	y=0		y=2		y=4		y=6		y=8		y=10	
	OMS	BM	OMS	BM	OMS	BM	OMS	BM	OMS	BM	OMS	BM
25	2.934	3.024	2.932	3.033	2.942	3.057	2.976	3.110	3.060	3.219	3.265	3.457
24	2.926	3.017	2.916	3.020	2.918	3.036	2.939	3.078	3.006	3.171	3.183	3.384
23	2.920	3.013	2.904	3.009	2.896	3.018	2.905	3.048	2.952	3.124	3.101	3.312
21	2.919	3.012	2.896	3.003	2.878	3.003	2.873	3.021	2.901	3.080	3.018	3.241
21	41.0	44.3	2.892	3.001	2.865	2.992	2.846	2.999	2.853	3.041	2.937	3.174
20	2.931	3.025	2.895	3.005	2.858	2.988	2.825	2.983	2.811	3.007	2.859	3.112
19	2.948	3.042	2.906	3.017	2.860	2.993	2.813	2.976	2.776	2.982	2.787	3.059
18	46.98	51.29	2.929	3.040	2.874	3.008	2.813	2.981	2.754	2.971	2.725	3.022
17	-82.29	-91.16	34.91	38.65	37.29	41.89	2.834	3.004	27.53	2.980	2.687	3.013
16	-108.7	-121.4	-100.4	-113.6	30.55	34.49	2.887	3.052	2.791	3.023	2.697	3.055

ORDINARY METHOD OF SLICES, MINIMUM FACTOR OF SAFETY : 2.687

BISHOPS MODIFIED METHOD, MINIMUM FACTOR OF SAFETY : 2.971

(1) $x = 76 \text{ m}$

Table A17- C = 4.5 t/m², $\phi_{fill} = 40^\circ$ (Run17)

Circle centers y(m) (1)	Ordinate of Lowest Point on the Circle (m)											
	y=0		y=2		y=4		y=6		y=8		y=10	
	OMS	BM	OMS	BM	OMS	BM	OMS	BM	OMS	BM	OMS	BM
25	2.926	3.009	2.921	3.014	2.926	3.032	2.951	3.075	3.016	3.163	3.167	3.345
24	2.918	3.003	2.906	3.002	2.903	3.012	2.916	3.044	2.964	3.117	3.090	3.276
23	2.914	2.999	2.895	2.992	2.883	2.995	2.883	3.015	2.914	3.072	3.013	3.208
22	2.913	3.000	2.887	2.986	2.866	2.981	2.854	2.990	2.866	3.031	2.937	3.143
21	40.917	43.65	2.885	2.986	2.854	2.972	2.829	2.970	2.821	2.994	2.862	3.080
20	2.926	3.014	2.889	2.991	2.849	2.969	2.810	2.955	2.782	2.963	2.790	3.023
19	2.945	3.032	2.901	3.004	2.852	2.975	2.800	2.951	2.751	2.941	2.724	2.975
18	40.934	50.58	2.925	3.028	2.868	2.992	2.803	2.958	2.733	2.933	2.671	2.943
17	-82.23	-89.60	34.869	38.06	37.22	41.14	2.826	2.983	2.736	2.946	2.640	2.940
16	-108.6	-119.1	-100.3	-111.3	30.50	33.89	2.881	3.035	2.779	2.993	2.659	2.989

ORDINARY METHOD OF SLICES, MINIMUM FACTOR OF SAFETY : 2.640

BISHOPS MODIFIED METHOD, MINIMUM FACTOR OF SAFETY : 2.933

(1) x = 76 m

Table A16- C = 4.5 t/m², $\phi_{fill} = 35^\circ$ (Run16)

Circle center y(m) (1)	Ordinate of Lowest Point on the Circle (m)											
	y=0		y=2		y=4		y=6		y=8		y=10	
	OMS	BM	OMS	BM	OMS	BM	OMS	BM	OMS	BM	OMS	BM
25	2.920	2.995	2.911	2.996	2.912	3.009	2.929	3.042	2.978	3.111	3.082	3.244
24	2.912	2.989	2.898	2.984	2.890	2.989	2.896	3.012	2.928	3.067	3.010	3.179
23	2.908	2.986	2.887	2.975	2.871	2.973	2.865	2.984	2.880	3.024	2.938	3.115
22	2.908	2.987	2.880	2.971	2.856	2.960	2.837	2.960	2.835	2.985	2.866	3.053
21	40.84	43.14	2.879	2.971	2.845	2.952	2.814	2.942	2.793	2.950	2.796	2.995
20	2.923	3.003	2.884	2.977	2.841	2.950	2.797	2.929	2.757	2.921	2.730	2.942
19	2.942	3.022	2.897	2.991	2.845	2.958	2.789	2.926	2.729	2.902	2.671	2.898
18	46.89	49.97	2.922	3.016	2.863	2.976	2.794	2.935	2.714	2.896	2.624	2.871
17	-82.17	-88.27	34.83	37.53	37.15	40.46	2.819	2.963	2.722	2.912	2.601	2.872
16	-108.6	-117.3	-100.3	-109.3	30.47	33.34	2.876	3.017	2.768	2.964	2.627	2.926

ORDINARY METHOD OF SLICES, MINIMUM FACTOR OF SAFETY : 2.601

BISHOPS MODIFIED METHOD, MINIMUM FACTOR OF SAFETY : 2.871

(1) x = 76 m

Table A15- H = 8 m, $\phi = 45^\circ$ (Run15)

Circle centers y(m) (1)	Ordinate of Lowest Point on the Circle (m)											
	y=12		y=14		y=16		y=18		y=20		y=4	
	OMS	BM	OMS	BM	OMS	BM	OMS	BM	OMS	BM	OMS	BM
43	1.030	1.078	1.056	1.107	1.099	1.153	1.175	1.282	1.319	1.382	.996	1.035
41	1.013	1.066	1.034	1.090	1.070	1.130	1.098	1.201	1.266	1.338	.991	1.032
39	.998	1.055	1.013	1.075	1.042	1.109	1.062	1.171	1.160	1.256	.989	1.031
37	.987	1.047	.996	1.063	1.017	1.091	1.029	1.144	1.213	1.296	.991	1.033
35	.980	1.044	.983	1.055	.996	1.078	1.015	1.123	1.110	1.223	21.64	27.93
34	.979	1.044	.979	1.053	.988	1.073	1.009	1.115	1.087	1.209	11.82	15.03
33.5	.980	1.045	.979	1.053	.985	1.072	1.004	1.112	1.077	1.204	34.15	44.97
33	.981	1.047	.979	1.054	.983	1.072	1.000	1.110	1.068	1.200	55.85	74.44
32.5	.983	1.049	.980	1.055	.982	1.072	.998	1.108	1.059	1.197	18.56	24.10
32	.986	1.051	.982	1.057	.982	1.073	.990	1.108	1.053	1.195	-33.8	-48.6

ORDINARY METHOD OF SLICES, MINIMUM FACTOR OF SAFETY : 0.979

BISHOPS MODIFIED METHOD, MINIMUM FACTOR OF SAFETY : 1.031

(1) x = 76 m

Table A14- H = 8 m, $\phi = 35^\circ$ (Run14)

Circle centers y(m) (1)	Ordinate of Lowest Point on the Circle (m)											
	y=12		y=14		y=16		y=18		y=20		y=4	
	OMS	BM	OMS	BM	OMS	BM	OMS	BM	OMS	BM	OMS	BM
43	.995	1.052	1.010	1.072	1.036	1.104	1.083	1.158	1.172	1.256	.982	1.024
41	.982	1.042	.993	1.059	1.013	1.086	1.053	1.133	1.131	1.222	.979	1.022
39	.972	1.034	.978	1.047	.992	1.070	1.023	1.110	1.091	1.191	.979	1.023
37	.964	1.030	.966	1.039	.974	1.056	.996	1.091	1.051	1.162	.982	1.026
35	.962	1.029	.958	1.035	.960	1.048	.974	1.077	1.016	1.140	21.46	26.02
34	.964	1.031	.958	1.035	.957	1.047	.965	1.073	1.001	1.133	11.74	14.12
33.5	.965	1.033	.958	1.036	.956	1.047	.962	1.072	.995	1.131	33.94	41.70
33	.968	1.035	.960	1.038	.956	1.048	.960	1.072	.990	1.130	55.54	68.77
32.5	.971	1.038	.963	1.040	.957	1.049	.959	1.073	.986	1.130	18.47	22.54
32	.975	1.041	.966	1.043	.959	1.052	.960	1.074	.983	1.131	-33.6	-1.35

ORDINARY METHOD OF SLICES, MINIMUM FACTOR OF SAFETY : 0.956

BISHOPS MODIFIED METHOD, MINIMUM FACTOR OF SAFETY : 1.022

(1) x = 76 m

Table A13- H = 6 m, $\phi = 45^\circ$ (Run13)

Circle centers y(m) (1)	Ordinate of Lowest Point on the Circle (m)											
	y=0		y=4		y=6		y=10		y=12		y=14	
	OMS	BM	OMS	BM	OMS	BM	OMS	BM	OMS	BM	OMS	BM
36	1.325	1.372	1.335	1.389	1.348	1.406	1.409	1.478	1.479	1.555	1.615	1.699
34	1.319	1.367	1.321	1.378	1.329	1.391	1.376	1.450	1.434	1.516	1.553	1.646
32	13.275	15.35	1.311	1.370	1.313	1.379	1.344	1.424	1.390	1.480	1.491	1.593
30	1.317	1.367	1.305	1.366	1.302	1.370	1.316	1.402	1.349	1.447	1.429	1.543
28	1.325	1.374	12.41	14.93	1.298	1.368	1.294	1.387	1.312	1.420	1.370	1.499
26	35.624	42.92	16.111	19.71	1.304	1.374	1.284	1.381	1.286	1.404	1.320	1.467
25.5	-36.81	-46.26	35.981	44.85	16.83	21.06	1.284	1.382	1.282	1.403	1.310	1.463
25	174.04	213.92	18.960	23.41	13.12	16.37	7.320	9.404	1.280	1.403	1.303	1.460
24.5	24.29	29.18	79.84	101.37	20.78	26.34	1.289	1.387	1.281	1.404	1.297	1.459
24	-48.52	-62.27	16.747	20.65	13.76	17.20	1.295	1.392	1.284	1.408	1.295	1.461

ORDINARY METHOD OF SLICES, MINIMUM FACTOR OF SAFETY : 1.280

BISHOPS MODIFIED METHOD, MINIMUM FACTOR OF SAFETY : 1.366

(1) x = 74.5 m

Table A12- H = 6 m, $\phi = 35^\circ$ (Run12)

Circle center y(m) (1)	Ordinate of Lowest Point on the Circle (m)											
	y=0		y=4		y=6		y=10		y=12		y=14	
	OMS	BM	OMS	BM	OMS	BM	OMS	BM	OMS	BM	OMS	BM
36	1.312	1.358	1.314	1.368	1.320	1.380	1.357	1.430	1.402	1.484	1.488	1.581
34	1.307	1.355	1.303	1.359	1.305	1.367	1.329	1.406	1.364	1.451	1.437	1.536
32	13.15	14.67	1.295	1.353	1.293	1.357	1.304	1.385	1.328	1.421	1.386	1.493
30	1.309	1.357	1.292	1.352	1.285	1.352	1.282	1.368	1.295	1.395	1.336	1.454
28	1.319	1.366	12.298	14.14	1.284	1.352	1.266	1.357	1.268	1.375	1.291	1.421
26	35.48	40.73	16.002	18.64	1.294	1.362	1.263	1.357	1.252	1.367	1.257	1.401
25.5	-36.6	-43.09	35.767	42.12	16.69	19.78	1.265	1.360	1.251	1.367	1.252	1.399
25	173.5	201.69	18.858	22.12	13.02	15.43	7.202	8.771	1.251	1.369	1.248	1.400
24.5	24.22	27.82	79.47	94.75	20.64	24.69	1.273	1.368	1.255	1.373	1.247	1.402
24	-48.41	-57.64	16.73	19.57	13.64	16.24	1.281	1.375	1.260	1.379	1.250	1.408

ORDINARY METHOD OF SLICES, MINIMUM FACTOR OF SAFETY : 1.247

BISHOPS MODIFIED METHOD, MINIMUM FACTOR OF SAFETY : 1.352

(1) x = 74.5 m

Table All- H = 4 m, $\phi = 45^\circ$ (Run11)

Circle center y(m) (1)	Ordinate of Lowest Point on the Circle (m)											
	y=0		y=2		y=4		y=6		y=8		y=10	
	OMS	BM	OMS	BM	OMS	BM	OMS	BM	OMS	BM	OMS	BM
25	1.972	2.040	1.977	2.054	1.994	2.081	2.036	2.136	2.132	2.249	2.380	2.520
24	1.965	2.034	1.965	2.043	1.976	2.065	2.008	2.111	2.090	2.212	2.314	2.462
23	1.960	2.030	1.955	2.035	1.959	2.050	1.981	2.088	2.048	2.176	2.248	2.405
22	1.958	2.029	1.947	2.028	1.944	2.038	1.956	2.067	2.008	2.142	2.182	2.348
21	27.511	30.64	1.943	2.025	1.932	2.029	1.934	2.049	1.969	2.110	2.115	2.293
20	1.962	2.034	1.943	2.026	1.924	2.023	1.915	2.035	1.933	2.082	2.049	2.241
19	1.972	2.043	1.948	2.032	1.923	2.023	1.903	2.026	1.903	2.059	1.987	2.194
18	31.43	35.60	1.961	2.044	1.929	2.030	1.898	2.025	1.880	2.045	1.930	2.157
17	-55.00	-64.11	23.367	26.94	25.01	29.45	1.907	2.035	1.871	2.044	1.887	2.139
16	-72.6	-85.71	-67.13	-80.72	20.456	24.18	1.936	2.061	1.887	2.063	1.875	2.153

ORDINARY METHOD OF SLICES, MINIMUM FACTOR OF SAFETY : 1.871

BISHOPS MODIFIED METHOD, MINIMUM FACTOR OF SAFETY : 2.023

(1) x = 76 m

Table A10- H = 4 m, $\phi = 35^\circ$ (Run 10)

Circle center y(m) (1)	Ordinate of Lowest Point on the Circle (m)											
	y=0		y=2		y=4		y=6		y=8		y=10	
	OMS	BM	OMS	BM	OMS	BM	OMS	BM	OMS	BM	OMS	BM
25	1.958	2.019	1.957	2.026	1.964	2.043	1.989	2.080	2.049	2.157	2.197	2.327
24	1.952	2.014	1.946	2.017	1.948	2.029	1.964	2.058	2.012	2.125	2.141	2.278
23	1.948	2.011	1.938	2.009	1.933	2.016	1.941	2.038	1.976	2.093	2.085	2.229
22	1.947	2.011	1.932	2.005	1.921	2.006	1.920	2.020	1.941	2.063	2.029	2.181
21	27.35	29.605	1.929	2.004	1.912	1.999	1.901	2.005	1.909	2.036	1.974	2.135
20	1.955	2.019	1.931	2.006	1.907	1.996	1.887	1.994	1.880	2.013	1.920	2.093
19	1.966	2.030	1.939	2.014	1.908	1.999	1.878	1.989	1.856	1.996	1.871	2.056
18	31.337	34.34	1.954	2.029	1.917	2.008	1.878	1.992	1.840	1.988	1.828	2.030
17	-54.87	-61.10	23.285	25.89	24.87	28.09	1.891	2.006	1.839	1.993	1.801	2.023
16	-72.49	-81.40	-66.93	-76.27	20.37	23.12	1.926	2.038	1.863	2.021	1.805	2.050

ORDINARY METHOD OF SLICES, MINIMUM FACTOR OF SAFETY : 1.801

BISHOPS MODIFIED METHOD, MINIMUM FACTOR OF SAFETY : 1.988

(1) x = 76 m

Table A9- H = 8 m, $\gamma = 2.1 \text{ t/m}^3$, $\phi = 45^\circ$, $c = 3 \text{ t/m}^2$ (Run9)

Circle centers y(m) (1)	Ordinate of Lowest Point on the Circle (m)													
	y=0		y=12		y=14		y=16		y=18		y=20		Toe Circles	
	OMS	BM	OMS	BM	OMS	BM	OMS	BM	OMS	BM	OMS	BM	OMS	BM
43	.950	.982	.986	1.030	1.013	1.059	1.057	1.105	1.134	1.184	1.279	1.335	2.007	2.121
41	.948	.982	.970	1.018	.991	1.042	1.028	1.082	1.096	1.153	1.227	1.291	1.863	1.986
39	.949	.983	.955	1.007	.953	1.015	1.001	1.061	1.058	1.123	1.122	1.210	1.715	1.850
37	.953	.987	.943	1.000	.971	1.027	.975	1.043	1.022	1.097	1.175	1.249	1.565	1.714
35	45.6	58.7	.936	.996	.940	1.007	.954	1.030	.989	1.075	1.072	1.176	1.414	1.584
34	-28.5	-38.9	.935	.996	.936	1.006	.946	1.026	.975	1.067	1.049	1.162	1.341	1.523
33,5	-414	-550	.935	.997	.935	1.005	.943	1.024	.969	1.064	1.039	1.157	1.306	1.494
33	30.6	39.5	.936	.998	.935	1.006	.941	1.023	.963	1.062	1.029	1.152	1.272	1.467
32,5	-14.6	-22.5	.938	1.000	.936	1.007	.939	1.023	.959	1.060	1.021	1.149	1.240	1.442
32	-36.8	-51,9	.941	1.02	.937	1.009	.939	1.024	.956	1.060	1.014	1.147	1.210	1.418

ORDINARY METHOD OF SLICES, MINIMUM FACTOR OF SAFETY : 0.935

BISHOPS MODIFIED METHOD, MINIMUM FACTOR OF SAFETY : 0.982

(1) x = 76 m

Table A8- $H = 8 \text{ m}$, $\gamma = 2 \text{ t/m}^3$, $\phi = 40^\circ$, $c = 3/\text{m}^2$ (Run 8)

Circle centers y(m) (1)	Ordinate of Lowest Point on the Circle (m)													
	y=0		y=12		y=14		y=16		y=18		y=20		Toe Circles	
	OMS	BM	OMS	BM	OMS	BM	OMS	BM	OMS	BM	OMS	BM	OMS	BM
43	.99	1.027	1.011	1.066	1.031	1.090	1.066	1.128	1.126	1.194	1.240	1.317	1.802	1.919
41	.989	1.026	.997	1.054	1.012	1.074	1.040	1.108	1.091	1.166	1.194	1.278	1.683	1.810
39	.991	1.029	.984	1.045	.994	1.061	1.015	1.089	1.058	1.140	1.147	1.242	1.561	1.701
37	.996	1.033	.975	1.039	.980	1.051	.994	1.074	1.027	1.118	1.102	1.208	1.438	1.594
35	50.3	62.2	.970	1.037	.970	1.045	.977	1.063	.999	1.100	1.060	1.181	1.317	1.495
34	-27.6	-35.7	.971	1.038	.968	1.045	.971	1.060	.989	1.094	1.041	1.171	1.259	1.450
33,5	-271	-343	.972	1.039	.968	1.045	.969	1.060	.984	1.092	1.033	1.167	1.232	1.429
33	32.4	40.1	.974	1.041	.969	1.046	.968	1.060	.981	1.091	1.026	1.164	1.206	1.411
32,5	-14.6	-20.5	.977	1.043	.970	1.048	.969	1.061	.978	1.091	1.020	1.163	1.182	1.394
32	-36.4	-48.1	.981	1.046	.973	1.051	.970	1.062	.977	1.092	1.016	1.163	1.161	1.379

ORDINARY METHOD OF SLICES, MINIMUM FACTOR OF SAFETY : 0.968

BISHOPS MODIFIED METHOD, MINIMUM FACTOR OF SAFETY : 1.026

(1) $x = 76 \text{ m}$

Table A7- Continued (Run7)

Circle centers y(m) (1)	Ordinate of Lowest Point on the Circle (m)							
	y=16		y=18		y=20		Toe Circle	
	OMS	BM	OMS	BM	OMS	BM	OMS	BM
43	1.083	1.155	1.129	1.209	1.216	1.305	1.632	1.750
41	1.060	1.137	1.098	1.183	1.174	1.271	1.535	1.663
39	1.038	1.120	1.068	1.160	1.133	1.239	1.436	1.577
37	1.020	1.107	1.041	1.141	1.093	1.211	1.336	1.495
35	1.007	1.099	1.018	1.127	1.058	1.189	1.241	1.421
34	1.003	1.098	1.010	1.123	1.043	1.182	1.197	1.389
33,5	1.002	1.098	1.007	1.122	1.037	1.180	1.176	1.376
33	1.003	1.099	1.005	1.122	1.032	1.179	1.158	1.364
32,5	1.004	1.101	1.005	1.124			1.141	1.354
32	1.007	1.104	1.006	1.126			1.127	1.347

ORDINARY METHOD OF SLICES, MINIMUM FACTOR OF SAFETY: 1.002

BISHOPS MODIFIED METHOD, MINIMUM FACTOR OF SAFETY : 1.075

(1) x = 76 m

Table A7 - $H = 8m$ $\gamma = 1.9 \text{ t/m}^3$ $\phi = 35^\circ$ (Run7)

Circle centers y(m) (1)	Ordinate of Lowest Point on the Circle (m)									
	y=0		y=2		y=4		y=12		y=14	
	OMS	BM	OMS	BM	OMS	BM	OMS	BM	OMS	BM
43	1.036	1.075	1.034	1.075	1.032	1.076	1.043	1.104	1.058	1.124
41	1.036	1.075	1.033	1.075	1.029	1.075	1.030	1.094	1.040	1.110
39	1.039	1.078	15.03	17.53	1.029	1.075	1.020	1.086	1.025	1.098
37	1.045	1.084	15.54	18.26	1.033	1.079	1.012	1.081	1.013	1.090
35	56.2	66.9	14.02	16.56	23.2	27.9	1.011	1.081	1.006	1.086
34	-26.8	-32.9	28.7	34.5	12.3	14.7	1.013	1.083	1.006	1.087
33,5	-201.7	-244.2	16.3	19.5	37.2	45.4	1.015	1.085	1.006	1.088
33	34.5	41.1	-95.4	-117.5	63.39	77.85	1.017	1.087	1.008	1.090
32,5	-14.6	-19.04	48.3	58.6						
32	-36.03	-45.02	18.2	21.74						

ORDINARY METHOD OF SLICES, MINIMUM FACTOR OF SAFETY : 1.002

BISHOPS MODIFIED METHOD, MINIMUM FACTOR OF SAFETY : 1.075

(1) x=76 m

Table A6- Continued (Run6)

Circle centers y_1 (m)	Ordinate of Lowest Point on the Circle (m)									
	y = 12						y = 14		Toe Circles	
	OMS	BM	OMS	BM	OMS	BM	OMS	BM	OMS	BM
36	1.481	1.502	1.421	1.491	1.431	1.502			2.529	2.653
34	1.387	1.465	1.377	1.453	1.387	1.465			2.354	2.489
32	1.345	1.431	1.334	1.418	1.345	1.431			2.171	2.320
30	1.306	1.400	1.293	1.385	1.306	1.400			1.981	2.148
28	1.271	1.376	1.256	1.358	1.271	1.376			1.787	1.980
26	1.248	1.363	1.230	1.342	1.248	1.363	1.267	1.407	1.597	1.827
25,5			1.226	1.341			1.257	1.402	1.553	1.793
25			1.224	1.340			1.249	1.398	1.511	1.763
24,5			1.224	1.341			1.243	1.397	1.473	1.736
24			1.226	1.344			1.241	1.398	1.440	1.715
(1) CIRCLE m ABCISSA	73	73	74.5	74.5	76	76	74.5	74.5	74.5	74.5

ORDINARY METHOD OF SLICES, MINIMUM FACTOR OF SAFETY: 1.224

BISHOPS MODIFIED METHOD, MINIMUM FACTOR OF SAFETY : 1.303

Table A6- $H = 6 \text{ m}$, $\gamma = 2.1 \text{ t/m}^3$, $\phi = 45^\circ$ (Run6)

Circle centers ⁽¹⁾ y(m)	Ordinate of Lowest Point on the Circle (m)											
	y = 0						y = 6					
	OMS	BM	OMS	BM	OMS	BM	OMS	BM	OMS	BM	OMS	BM
36	1.267	1.311	1.264	1.308	1.267	1.311	1.292	1.348	1.288	1.343	1.292	1.348
34	1.261	1.307	1.258	1.304	1.261	1.307	1.214	1.333	1.270	1.328	1.274	1.333
32	1.258	1.305	12.66	14.72	1.258	1.305	1.259	1.321	1.254	1.316	1.260	1.322
30	1.259	1.307	1.256	1.303	1.259	1.307	1.249	1.314	1.243	1.307	1.249	1.314
28	1.267	1.314	1.263	1.310	31.83	38.18	1.245	1.312	1.238	1.305	1.244	1.312
26	-108.11	-134.43	33.5	40.664	28.04	33.92	1.251	1.319	1.243	1.311	1.251	1.319
(1) CIRCLE ABCISSA, m	73	73	74.5	74.5	76	76	73	73	74.5	74.5	76	76

BOGAZICI UNIVERSITY

Table A5- Continued (Run5)

Circle centers y_1 (m)	Ordinate of Lowest Point on the Circle (m)									
	y = 12						y = 14		Toe Circles	
	OMS	BM	OMS	BM	OMS	BM	OMS	BM	OMS	BM
36	1.447	1.529	1.438	1.519	1.447	1.529			2.277	2.400
34	1.407	1.495	1.397	1.483	1.407	1.495			2.131	2.265
32	1.368	1.463	1.357	1.450	1.368	1.463			1.979	2.128
30	1.333	1.436	1.320	1.421	1.333	1.436			1.823	1.991
28	1.303	1.415	1.288	1.397	1.303	1.415			1.666	1.860
26	1.286	1.407	1.268	1.386	1.286	1.407	1.286	1.434	1.516	1.746
25,5			1.265	1.385			1.279	1.431	1.482	1.723
25			1.265	1.386			1.273	1.430	1.451	1.703
24,5			1.267	1.389			1.270	1.431	1.424	1.688
24			1.271	1.394			1.271	1.435	1.403	1.677
(1) CIRCLE ABCISSA	73	73	74.5	74.5	76	76	74.5	74.5	74.5	74.5

ORDINARY METHOD OF SLICES, MINIMUM FACTOR OF SAFETY: 1.265

BISHOPS MODIFIED METHOD, MINIMUM FACTOR OF SAFETY : 1.360

Table A5- $H = 6 \text{ m}$, $\gamma = 2 \text{ t/m}^3$, $\phi = 40^\circ$ (Run5)

Circle centers $y(\text{m})$	Ordinate of Lowest Point on the Circle (m)											
	$y = 0$						$y = 6$					
	OMS	BM	OMS	BM	OMS	BM	OMS	BM	OMS	BM	OMS	BM
36	1.321	1.368	1.318	1.365	1.321	1.368	1.337	1.398	1.333	1.393	1.337	1.398
34	1.316	1.364	1.313	1.361	1.316	1.364	1.321	1.385	1.316	1.379	1.321	1.385
32	1.314	1.363	13.21	14.99	1.314	1.363	1.308	1.374	1.302	1.368	1.308	1.374
30	1.317	1.367	1.313	1.362	1.317	13.67	1.299	1.368	1.293	1.361	1.299	1.368
28	1.326	1.375	1.322	1.370	34.2	39.84	1.297	1.368	1.290	1.360	1.297	1.368
26	-95.97	-114.68	35.5	41.75	29.5	34.63	1.307	1.377	1.299	1.368	1.307	1.377
(1) CIRCLE ABCISSA, m	73	73	74.5	74.5	76	76	73	73	74.5	74.5	76	76

Table A4- Continued (Run4)

Circle centers y_1 (m)	Ordinate of Lowest Point on the Circle (m)									
	y = 12						y = 14		Toe Circles	
	OMS	BM	OMS	BM	OMS	BM	OMS	BM	OMS	BM
36	1.476	1.563	1.466	1.552	1.476	1.563			2.068	2.188
34	1.438	1.531	1.427	1.519	1.438	1.531			1.948	2.079
32	1.402	1.501	1.390	1.488	1.402	1.501			1.823	1.969
30	1.370	1.476	1.357	1.461	1.370	1.476			1.696	1.861
28	1.344	1.459	1.329	1.441	1.344	1.459			1.570	1.761
26	1.332	1.455	1.313	1.433	1.332	1.455	1.315	1.465	1.455	1.681
25,5			1.313	1.434			1.310	1.464	1.431	1.666
25			1.314	1.437			1.307	1.465	1.409	1.656
24,5			1.317	1.441			1.307	1.468	1.392	1.650
24			1.324	1.448			1.310	1.474	1.381	1.649
(1) CIRCLE ABCISSA	73	73	74.5	74.5	76	76	74.5	74.5	74.5	74.5

ORDINARY METHOD OF SLICES, MINIMUM FACTOR OF SAFETY: 1.307

BISHOPS MODIFIED METHOD, MINIMUM FACTOR OF SAFETY : 1.420

Table A4- H = 6 m, $\gamma = 1.9 \text{ t/m}^3$ $\phi = 35^\circ$ (Run 4)

Circle (f) centers y(m)	Ordinate of Lowest Point on the Circle (m)											
	y = 0						y = 6					
	OMS	BM	OMS	BM	OMS	BM	OMS	BM	OMS	BM	OMS	BM
36	1.382	1.430	1.379	1.428	1.382	1.430	1.391	1.454	1.386	1.449	1.391	1.454
34	1.378	1.427	1.375	1.424	1.378	1.427	1.376	1.441	1.371	1.436	1.376	1.441
32	1.377	1.427	13.9	15.35	1.377	1.427	1.364	1.432	1.358	1.425	1.364	1.432
30	1.381	1.432	1.377	1.427	1.381	1.432	1.357	1.427	1.350	1.420	1.357	1.427
28	1.392	1.442	1.388	1.437	37.1	42.01	1.357	1.429	1.350	1.421	1.357	1.429
26	-86.27	-99.62	37.8	43.24	31.26	35.62	1.370	1.441	1.361	1.432	1.369	1.441
(1) CIRCLE ABCISSA, m	73	73	74.5	74.5	76	76	73	73	74.5	74.5	76	76

Table A3- H = 4 m, $\gamma = 2.1 \text{ t/m}^3$, $\phi = 45^\circ$ (Run3)

Circle centers y(m) (1)	Ordinate of Lowest Point on the Circle (m)											
	y=0		y=2		y=4		y=6		y=8		y=10	
	OMS	BM	OMS	BM	OMS	BM	OMS	BM	OMS	BM	OMS	BM
25	1.881	1.946	1.886	1.960	1.904	1.987	1.946	2.042	2.044	2.156	2.295	2.430
24	1.814	1.940	1.874	1.949	1.886	1.972	1.919	2.018	2.003	2.120	2.234	2.373
23	1.869	1.936	1.864	1.941	1.869	1.957	1.893	1.996	1.962	2.085	2.167	2.317
22	1.866	1.934	1.857	1.935	1.855	1.945	1.868	1.975	1.923	2.051	2.102	2.261
21	25.9	28.9	1.852	1.932	1.843	1.936	1.847	1.958	1.885	2.020	2.037	2.207
20	1.810	1.939	1.852	1.932	1.835	1.931	1.828	1.944	1.850	1.993	1.972	2.156
19	1.880	1.948	1.857	1.937	1.833	1.930	1.816	1.935	1.819	1.970	1.910	2.110
18	29.89	34.03	1.869	1.949	1.839	1.937	1.811	1.933	1.797	1.955	1.854	2.073
17	-56.5	-66.4	22.27	25.82	23.53	27.88	1.818	1.942	1.787	1.953	1.811	2.053
16	-73.31	-87.2	-69.49	-84.25	19.49	23.20	1.846	1.966	1.801	1.970	1.796	2.065

ORDINARY METHOD OF SLICES, MINIMUM FACTOR OF SAFETY : 1.787

BISHOPS MODIFIED METHOD, MINIMUM FACTOR OF SAFETY : 1.930

(1) x = 76 m

Table A2- H = 4 m, $\gamma = 2 \text{ t/m}^3$, $\phi = 40^\circ$ (Run2)

Circle center y(m) (1)	Ordinate of Lowest Point on the Circle (m)											
	y=0		y= 2		y= 4		y= 6		y= 8		y= 10	
	OMS	BM	OMS	BM	OMS	BM	OMS	BM	OMS	BM	OMS	BM
25	1.965	2.030	1.966	2.039	1.978	2.062	2.011	2.108	2.088	2.202	2.280	2.419
24	1.958	2.024	1.955	2.030	1.961	2.047	1.984	2.084	2.048	2.167	2.222	2.366
23	1.954	2.021	1.946	2.022	1.945	2.033	1.959	2.063	2.010	2.133	2.161	2.313
22	1.952	2.020	1.939	2.017	1.932	2.022	1.936	2.043	1.972	2.102	2.100	2.260
21	27.426	30.09	1.936	2.015	1.921	2.014	1.916	2.027	1.937	2.072	2.039	2.210
20	1.958	2.027	1.936	2.016	1.915	2.010	1.900	2.014	1.905	2.047	1.980	2.164
19	1.969	2.037	1.943	2.023	1.915	2.011	1.890	2.008	1.877	2.027	1.924	2.123
18	31.38	34.93	1.957	2.037	1.923	2.020	1.887	2.009	1.859	2.016	1.875	2.092
17	-54.93	-62.48	23.32	26.39	24.94	28.73	1.889	2.021	1.854	2.019	1.841	2.079
16	-72.54	-83.37	-67.05	-78.33	20.41	23.62	1.931	2.050	1.874	2.042	1.837	2.100

ORDINARY METHOD OF SLICES, MINIMUM FACTOR OF SAFETY : 1.837

BISHOPS MODIFIED METHOD, MINIMUM FACTOR OF SAFETY : 2.008

(1) x = 76 m

Table A1- H = 4 m, $\gamma = 1.9 \text{ t/m}^3$, $\phi = 35^\circ$ (Run1)

Circle centers y(m) (1)	Ordinate of Lowest Point on the Circle (m)											
	y=0		y=2		y=4		y=6		y=8		y=10	
	OMS	BM	OMS	BM	OMS	BM	OMS	BM	OMS	BM	OMS	BM
25	2.059	2.122	2.057	2.128	2.064	2.145	2.088	2.182	2.147	2.259	2.290	2.425
24	2.053	2.117	2.046	2.119	2.047	2.130	2.062	2.159	2.109	2.225	2.233	2.374
23	2.049	2.114	2.038	2.112	2.032	2.117	2.038	2.138	2.109	2.192	2.175	2.325
22	2.048	2.114	2.032	2.107	2.020	2.107	2.016	2.120	2.036	2.161	2.117	2.274
21	29.17	31.46	2.029	2.106	2.010	2.100	1.997	2.104	2.002	2.133	2.061	2.227
20	2.056	2.123	2.032	2.109	2.005	2.097	1.982	2.093	1.972	2.110	2.006	2.183
19	2.069	2.135	2.040	2.117	2.007	2.100	1.974	2.088	1.948	2.092	1.955	2.146
18	33.05	36.07	2.056	2.133	2.017	2.111	1.975	2.092	1.932	2.084	1.912	2.120
17	-53.39	-59.16	24.498	27.12	26.56	29.84	1.980	2.108	1.932	2.091	1.885	2.114
16	-71.80	-80.20	-64.78	-73.50	21.43	24.20	2.026	2.142	1.959	2.121	1.892	2.143

ORDINARY METHOD OF SLICES, MINIMUM FACTOR OF SAFETY : 1.885

BISHOPS MODIFIED METHOD, MINIMUM FACTOR OF SAFETY : 2.084

(1) x = 76 m