

FOR REFERENCE

DO NOT REMOVE FROM THIS BOOK

AVAILABLE ENERGY ANALYSIS  
OF A PETROLEUM REFINERY

BY

DENİZ ERKAN

B.S. in Chemical Engineering  
Istanbul Technical University  
Faculty of Chemistry

1980

Submitted to the Institute for Graduate Studies

in Science and Engineering  
in Partial Fulfillment of  
the Requirements for the Degree of

Master of Science

in

Chemical Engineering

Bogazici University Library



39001100315228

14

BOĞAZIÇI UNIVERSITY

1984

### ACKNOWLEDGEMENTS

I would like to thank my thesis supervisor Doç. Dr. Salih DİNÇER for his great interest, creative advice, understanding and help throughout this work.

I also want to express my thanks to Prof. Dr. Turgut NOYAN, the Chairman of the Chemical Engineering Department, for his interest.

In addition, I would like to thank Orhan GENİŞ and Süha SOLAKOĞLU of İPRAŞ for supplying the necessary information about the refinery.

## ABSTRACT

The aim of this thesis is to examine the concept of available energy (availability) as applied to a petroleum refinery. For this purpose two different parts of the refinery were investigated. The first part, namely the plant 5 of İPRAŞ Refinery, deals mainly with separation and heat transfer processes. The second part, namely the Plant 6 of İPRAŞ Refinery, deals mainly with chemical reaction processes. The data needed in the calculation for Plant 5 were supplied by İPRAŞ. However, since Plant 6 involves chemical reactions and in chemically reacting systems standard chemical availabilities are needed and these standard chemical availabilities had to be simply estimated because of the uncertain structure of fractions. Therefore, the availability calculations carried out for Plant 6 are quite approximate and they are preliminary in nature.

In addition, an availability analysis was made for each equipment of Plant 5 to investigate where the availability losses occurred. The majority of process availability losses are in the furnaces, heat exchangers before desalters and in the air and water coolers. The availability loss of the overall process was also calculated for Plant 5 by an overall balance. For Plant 6, on the other hand, the availability calculations were made approximately only for

the overall process because of the lack of necessary data. In addition, an availability efficiency, which is also called Second Law efficiency in literature, was defined and it was reduced to suitable forms for different equipment.

## ÖZET

Bu tezin amacı kullanılabilir enerji ilkesinin bir petrol rafinerisine uygulanışını incelemektir. Bu amaçla İPRAŞ petrol rafinerisinin iki farklı bölümü incelenmiştir. Birinci bölüm Plant 5 ünitesi olup genellikle ayırma ve ısı aktarımı süreçlerini içerir. İkinci bölüm ise Plant 6 ünitesi olup genelde kimyasal tepkime süreçlerini içerir. Plant 5 hesaplamaları için gerekli ham veriler İPRAŞ'tan alınmıştır. Plant 6 kimyasal süreçler içerdiğinden akımların standart kimyasal kullanılabilir enerjilerinin bilinmesine gerek vardır. Akımların bileşimi tam olarak bilinmediğinden standart kimyasal kullanılabilir enerjileri tahmini olarak hesaplanmıştır. Bu nedenle Plant 6 için yapılan kullanılabilir enerji analizi oldukça yaklaşıktır.

Kullanılabilir enerji kayıplarının olduğu yerleri gözleyebilmek için Plant 5 ünitesinin her bir birimi ayrı ayrı incelenmiştir. Bu üniteye önemli kullanılabilir enerji kayıplarının fırınlarda, tuz ayırıcılarının önündeki ısı değiştiricilerde, hava ve su soğutucularında olduğu tespit edilmiştir. Ayrıca Plant 5 için toplam kullanılabilir enerji kaybı, kullanılabilir enerji dengesinden hesaplanmıştır. Plant 6 için yeterli veri olmadığından sadece bütün üniteyi içeren yaklaşık bir kullanılabilir enerji hesaplaması yapılmıştır. Ayrıca, kaynaklarda ikinci

Yasa verimliliđi olarak da adlandırılan kullanılabilir enerji verimliliđi Plant 5'in akım şemasında gösterilen birimler için uygun bir şekilde tarif edilmiştir.

TABLE OF CONTENTS

Acknowledgements .....	i
Abstract .....	ii
Özet .....	iv
Table of Contents .....	vi
List of Tables .....	viii
List of Figures .....	xi
List of Symbols .....	xii
0- INTRODUCTION .....	1
1- THERMODYNAMICS OF AVAILABILITY ANALYSIS FOR STEADY FLOW PROCESSES.....	4
2- AVAILABILITY ANALYSIS OF PLANT 5 AND PLANT 6 .....	11
2.1. Determination of Enthalpy and Entropy of Petroleum Fractions and Refinery Gases.....	11
2.1.1 Determination of Specific Heat .....	11
2.1.1.1 Specific Heat of the Petroleum Fractions.....	11
2.1.1.2 Specific Heat of Refinery Gases	12
2.1.2. Enthalpy and Entropy of Petroleum Fractions .....	13
2.1.3. Enthalpy and Entropy Changes due to Mixing .....	14
2.1.4. Enthalpy and Entropy Changes in the Atmospheric overhead vapor .....	15
2.2. Calculation of Availability of a Stream .....	16
2.3. Available Energy Loss .....	16

2.4. Availability Efficiency .....	18
2.4.1 Heat exchanger .....	19
2.4.2 Furnace .....	19
2.4.3 Pump .....	19
2.4.4 Separator .....	20
3- RESULTS AND DISCUSSION .....	22
3.1. Plant 5 .....	22
3.2. Plant 6 .....	34
4- CONCLUSION AND RECOMMENDATIONS .....	38
LIST OF REFERENCES .....	41
APPENDICES	
APPENDIX 1 RAW DATA FOR PLANT 5 .....	45
APPENDIX 2 RAW DATA FOR PLANT 6 .....	67
APPENDIX 3 AVAILABILITY ANALYSIS FOR	
INDIVIDUAL UNITS IN PLANT 5 .....	73
APPENDIX 4 AVAILABILITY CALCULATIONS FOR PLANT 6	94
APPENDIX 5 SAMPLE CALCULATIONS FOR PLANT 5 .....	102
APPENDIX 6 HEAT AVAILABILITY DIAGRAM IN CONNECTION	
WITH PLANT 5 .....	106

LIST OF TABLES

TABLE

3.1.1. Unit Symbols and Meanings .....	25
3.1.2. Summary of Availability Analysis of each unit in Plant 5 .....	26
3.1.3. Availability Losses in Air and Water Coolers	30
3.1.4. The Percentage of Total Availability Loss in each Equipment in Plant 5 .....	31
3.2.1. Availability Calculations for Overall Plant 6	35
A.1.1. Raw Data for Plant 5 .....	46
A.1.2. Compositions of Refinery Gases in Plant 5 ..	63
A.1.3. Constants of Molar Heat Capacities of Inorganic Gases .....	64
A.1.4. Constants of Molar Heat Capacities of Organic Gases .....	64
A.1.5. Availability Supplied to the Pumps in Plant 5	65
A.1.6. Availability Supplied to the Furnaces in Plant 5 .....	66
A.2.1. Raw Data for Overall Plant 6 .....	68
A.2.2. Compositions of Refinery Gases in Plant 6 ..	69
A.2.3. Compositions of Liquid Phases in Plant 6 ...	70
A.2.4. Standard Chemical Availabilities of Components in Plant 6 .....	71
A.2.5. Availability Supplied to the Furnaces and Pumps in Plant 6 .....	72
A.3.1. Availability Analysis for Atmospheric Distillation Column .....	75

A.3.2. Availability Analysis for the Combination of Atmospheric Distillation Column and Furnaces Used to Heat the Feed .....	77
A.3.3. Availability Analysis for Vacuum Column .....	79
A.3.4. Availability Analysis for Vacuum Column and Furnace Used to Heat the Feed .....	81
A.3.5. Availability Analysis for the Stripper .....	82
A.3.6. Availability Analysis for the Debutanizer Column .....	83
A.3.7. Availability Analysis for the Debutanizer Overhead Drum .....	84
A.3.8. Availability Analysis for the Atmospheric Overhead Drum .....	85
A.3.9. Availability Analysis of Streams Related to the Furnaces .....	86
A.3.10 Availability Analysis for Heat Exchanger before Desalters .....	87
A.3.11 Availability Analysis for Heat Exchanger after Desalters .....	89
A.3.12 Availability Analysis for Pumps .....	92
A.3.13 Availability Analysis for Overall Plant 5 .....	93
A.4.1. Results of Enthalpy, Entropy and Standart Chemical Availability Calculations for Stream 19 .....	99
A.4.2. Results of Enthalpy, Entropy and Standart Chemical Availability Calculations for Stream 25 .....	100

A.4.3. Results of Enthalpy, Entropy and Standart

Chemical Availability Calculations for

Stream 29 ..... 101

LIST OF FIGURES

FIGURE

1.1. A steady flow process .....	4
1.2. Gas expanding through turbines .....	6
1.3. T-S diagram for turbines . . . . .	7
2.1 A separator .....	20
3.1. Flowsheet of Plant 5 .....	24
3.2. Sketch showing results of overall availability analysis for Plant 5 .....	32
3.3. Flowsheet of Plant 6 .....	36
A.3.1. Atmospheric distillation column .....	74
A.3.2. Combination of atmospheric distillation column and furnaces used to heat the feed ..	76
A.3.3. Vacuum distillation column .....	78
A.3.4. Vacuum distillation column and furnace used to heat the feed.....	80
A.6.1. Heat availability diagram .....	109

LIST OF SYMBOLS

- $A_v$ - Availability  
 $A_{v_0}$  - Standard chemical availability  
 $^{\circ}\text{API}$ - API gravity  
 $C_p$ - Specific heat  
 $G^{\circ}_f$ - Standard Gibbs free energy of formation  
H- Enthalpy  
K.E.- Kinetic energy  
 $K_w$ - Watson characterization factor  
O/H- Overhead  
O/I- output/input  
 $P_0$ - Reference pressure  
P- pressure  
P.E.- Potential energy  
Q- Heat  
 $Q_H$ - Heat supplied to the system  
 $Q_C$ - Heat rejected from the system  
R- Universal gas constant  
S- Entropy  
S.G.- Specific gravity  
 $T_0$ - Reference temperature  
T- System temperature  
 $T_H$ - Hot reservoir temperature  
 $T_C$ - Cold reservoir temperature  
V- Volume

$W_s$  - Shaft work

$X_i$  - Mole fraction of component  $i$  in a liquid phase

$y_i$  - Mole fraction of component  $i$  in a gas phase

$\eta$  - Efficiency

$\rho$  - Density

Superscript

<sup>o</sup> - standard conditions

Subscripts

cons- constant

f- formation

gen- generated

mech- mechanical

mix- mixing

sep- separation (opposite of mixing)

supp- supplied

o- standard surroundings

l- any condition other than standard surroundings.

0- INTRODUCTION

Most processes involve the exchange of energy, in the form of work and heat. It is essential that with the rapidly rising energy costs, new processes should be developed or the existing processes should be improved to increase the efficiency of energy consumption and thus decrease the amount of energy consumed.

The cost of energy depends not only on the quantity used but to a very large measure on its quality. Conventional energy analysis of a process commonly consists of conducting energy balance around the process, an approach based on the First Law of Thermodynamics. The First Law analysis is based on the quantity of energy, not on the quality of energy. Different forms of energy have different qualities. The quality of an energy stream depends on the work available from that stream because different energy sources produce different amounts of work. For example; one hundred Joules of electricity may be completely converted into work. Therefore, electricity is a high quality energy. On the other hand 100 kJ of 101.3 kPa steam (low pressure steam) may produce only about 18 kJ of work. Therefore low pressure steam is a low quality energy. The work available from an energy source is expressed in terms of a thermodynamic property called AVAILABILITY. Availability (available energy) is the same as the theoretical maximum

work that may be obtained from an energy source when the material in that source is moved by completely reversible processes into equilibrium with surroundings. The efficiency of energy utilisation in processes can not and should not be evaluated based on the First Law of Thermodynamics alone since energy calculated from First Law is degradable. Therefore available energy concept, which is based on Second Law of Thermodynamics should be applied for energy analysis of processes.

Although the concept of availability was given by Gibbs and Maxwell (9) more than one hundred years ago, it was only in recent years that it gained general acceptance as an appropriate criteria for evaluating the efficiency of chemical and physical processes. A number of articles available in the literature elaborate on the application of available energy concept to various chemical processes such as coal gasification (3,10), coal liquefaction (2), sulfuric acid production (16), methane reforming (21), etc. In general, thermodynamic availability analysis of processes is a powerful tool that can pinpoint inefficiencies in the processing steps, thus measures can be taken to eliminate such inefficiencies. At least, the traditional energy (enthalpy) balances must be supplemented by availability balances.

In this work, the concept of thermodynamic available energy analysis was applied to Plant 5 and Plant 6 of İPRAŞ Refinery. In Plant 5; enthalpies, entropies, availabilities for each stream were calculated. Then the loss of available energy for each unit was determined. The availability loss was then summed over the total system, to yield the total plant availability loss. The availability efficiency, which shows the efficiency of energy utilisation, is calculated for each unit of Plant 5. For Plant 6, on the other hand, the availability calculations were carried out only for the overall plant and they are preliminary in nature.

In this thesis, Chapter 1 covers the theory of thermodynamics of availability analysis, Chapter 2 covers introduction of equations necessary for availability analysis of Plants 5 and 6 in İPRAŞ Refinery and Chapter 3 presents results of availability analysis calculations for Plants 5 and 6.

## 1. THERMODYNAMICS OF AVAILABILITY ANALYSIS FOR STEADY FLOW PROCESSES

A steady flow process is a process in which the temperature and mass at any fixed location do not change with time, although matter and energy flow steadily into and out of the process. Engineering equipment generally operate under such conditions. Fig. 1.1 represents a steady flow process. The mass entering ( $m_1$ ) at a temperature  $T_1$  and pressure  $P_1$  is equal to that leaving ( $m_2$ ) at a temperature  $T_2$  and pressure  $P_2$ . Energy may enter or leave through the walls of the process as heat ( $Q$ ) or as shaft work ( $W_s$ ). Energy also enters and leaves as enthalpy ( $H$ ), potential energy (P.E.) and kinetic energy (K.E.).

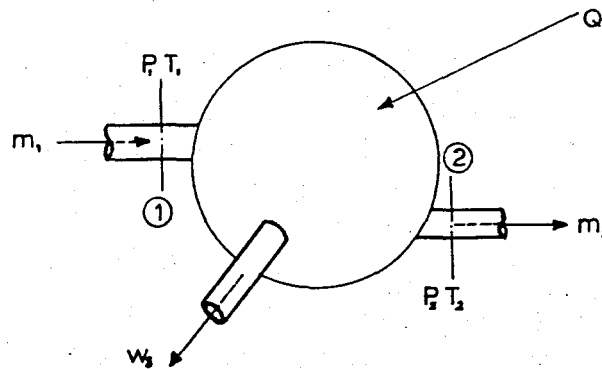

Figure 1.1. A Steady Flow Process

Energy conservation for a steady flow process can be written as:

$$Q - W_s = \Delta H + \Delta(\text{P.E.}) + \Delta(\text{K.E.}) \quad (1.1)$$

where  $W_s$  is the work output of a steady flow process. The availability is the maximum amount of work which can be

extracted from the system when that system is allowed to come into equilibrium with the surrounding environment. Therefore the conditions must be examined to make shaft work a maximum.

A gas system is selected to define availability function and to show the relationship between shaft work and availability. Suppose a gas system is in an initial state (1) that is not at the same temperature, pressure and concentration as its surroundings and it is moved by a series of steady flow processes to a state (o) that is in equilibrium with the surroundings. If the maximum work is to be obtained from this change of state, the processes from its initial state to final state must be totally reversible. The reversible process must be such that heat transfer occurs only when the system is at the temperature of the surroundings, mass transfer occurs only after the system has reached the concentration of the surroundings and all mechanical work effects occur without friction and with infinitesimal force imbalance. Therefore, processes must be chosen such that they should transfer heat only after the system has reached the temperature of the surroundings ( $T_o$ ) and transfer matter to the surroundings only when the system is at the pressure and concentration of the surroundings.

A possible set of steady flow processes is shown in Fig. 1.2. The gas at its initial temperature  $T_1$ , and

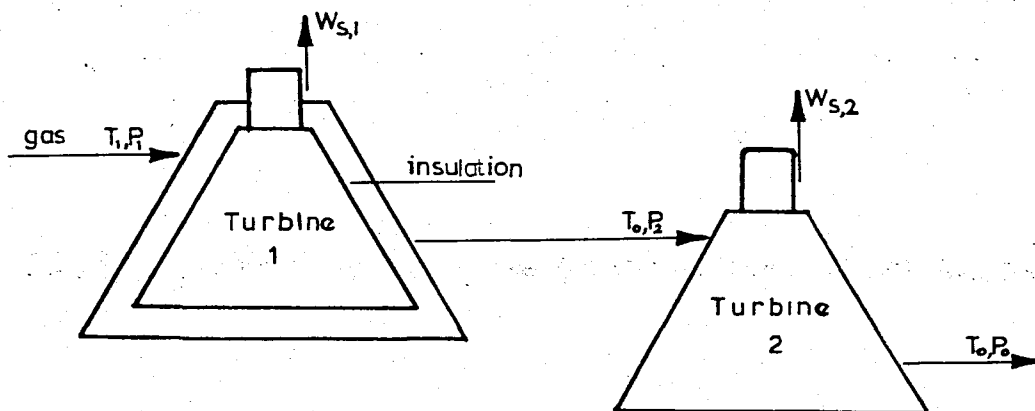

Figure 1.2. Gas Expanding Through Turbines  
pressure  $P_1$  flows at constant rate through a perfectly insulated frictionless turbine I, where it expands reversibly and drives the turbine shaft. No heat enters or leaves turbine I. The gas cools because it gives up energy to the turbine shaft. The expansion continues until the gas temperature falls to the temperature of the atmosphere,  $T_0$ , at which point it is transferred to a second uninsulated turbine II which runs at  $T_0$ . The pressure of the gas entering turbine II is  $P_2$ . The expansion in turbine II proceeds isothermally until the pressure falls to the pressure of the atmosphere ( $P_0$ ). Heat must continuously enter the second turbine to maintain the temperature at  $T_0$ .

These processes are shown graphically in Fig. 1.3. Process (1-2) occurs reversibly and adiabatically. Therefore it is isentropic. Process (2-0) is isothermal. From Eq. (1.1), the shaft work from the above set of processes must be:

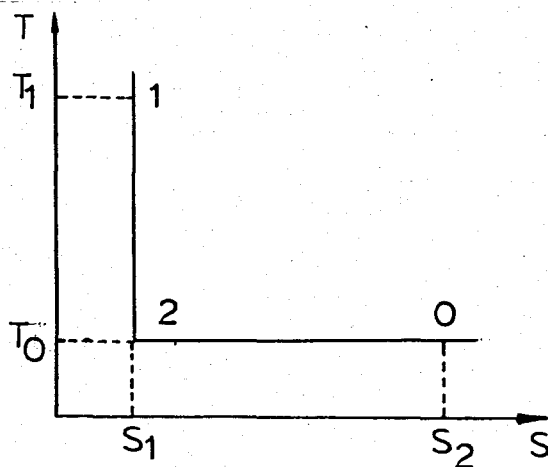

Figure 1.3. T-S Diagram for Turbines

$$W_S \text{ (reversible)} = -(\Delta H_{1-0} - Q_{\text{rev}} + \Delta(\text{P.E.})_{1-0} + \Delta(\text{K.E.})_{1-0}) \quad (1.2)$$

$W_S$  (reversible) is the total shaft work from turbines I and II, and it is the maximum that can be extracted from a material flowing from an initial state (1) to atmospheric conditions (0). All the heat transfer occurs reversibly so that

$$Q_{\text{rev}} = \int_1^0 T ds \quad (1.3)$$

However, according to definition, heat is transferred only when the gas is at  $T_0$ . Therefore Eq. (1.3) becomes:

$$Q_{\text{rev}} = T_0 \Delta S_{1-0} \quad (1.4)$$

Then, Eq. (1.2) becomes:

$$W_{S, \text{max}} = -(\Delta H_{1-0} - T_0 \Delta S_{1-0} + \Delta(\text{P.E.})_{1-0} + \Delta(\text{K.E.})_{1-0}) \quad (1.5)$$

When kinetic and potential energy effects are insignificant, Eq. (1.5) becomes:

$$W_{S, \text{max}} = -(\Delta H_{1-0} - T_0 \Delta S_{1-0}) \quad (1.6)$$

At this point, we define  $A_v = W_{S, \text{max}}$ , where  $A_v$  stands for availability function. Then the availability of a material

at state 1 with respect to surroundings is written as:

$$A_{v_1} = -(\Delta H_{1-o} - T_o \Delta S_{1-o}) \quad (1.7)$$

or

$$A_{v_1} = \Delta H_{o-1} - T_o \Delta S_{o-1} \quad (1.7a)$$

Eq. (1.6) can also be used to calculate the least amount of work needed in a steady flow process.

If a material moves through a flow process from an initial state (1) to a final state (2), that is not the atmospheric conditions, availability change is given as:

$$\Delta A_{v_{1-2}} = (A_{v_2} - A_{v_1}) = -(H_o - H_2 - T_o (S_o - S_2)) + (H_o - H_1 - T_o (S_o - S_1))$$

or

$$\Delta A_{v_{1-2}} = (H_2 - H_1) - T_o (S_2 - S_1) \quad (1.8)$$

or in general form

$$\Delta A_v = \Delta H - T_o \Delta S \quad (1.9)$$

Although Eqs. (1.7)-(1.9) are derived by considering a gas flowing through the process given in Fig. 1.2, these equations are perfectly general  $\Delta A_v$  depends only on the initial and final states and is independent of path.

Similarly,  $\Delta H$  and  $\Delta S$  are the enthalpy and entropy changes of a unit mass of matter moving from the initial state to the final state and are independent of path.

Availability is computed with respect to a reference state. In this work, for chemically nonreacting systems, availabilities are based on standard atmosphere and Eq. 1.7 is used directly. When considering availability changes in chemically nonreacting systems, reference state does not effect the results. In chemical processes which

involve chemical reactions, since species change their forms, the computation of the availability of reactive chemicals is based on a reference state or rest state defined in terms of " the products of combustion in the form of  $H_2O$  (liquid),  $CO_2$ (g), etc. each pure, and in their normal state of aggregation at 298K and 101.3 kPa(22).

In this case, the availability of any pure material at 298K and 101.3kPa is the negative of its standard free energy of combustion, i.e, its standard free energies of formation minus the standard free energies of formation of its combustion products. This quantity is called STANDARD CHEMICAL AVAILABILITY and is shown by the symbol  $A_{V_0}$  :

$$A_{V_0} = \Delta G_f^0 - \sum \Delta G_j n_j \text{ (all combustion products)} \quad (1.10)$$

Then the availability of any pure reactive material in state (1) with respect to the standard reference environment is:

$$A_{V_1} = A_{V_0} + \Delta A_{V_0-1} \quad (1.11)$$

where  $A_{V_0}$  is the standard chemical availability and  $\Delta A_{V_0-1}$  is the availability change in moving the pure material from standard reference environment to the state (1) and is calculated by Eq. (1.7a). If a material is a component of a reference state, then  $A_{V_0}$  is zero and its availability is given by  $\Delta A_{V_0-1}$  only. However, in a process where there is no chemical reaction such as a separation process, there is no need to use the standard chemical availability because  $A_{V_0}$  of a material in state (1) would be the same

as  $A_{y_0}$  of the material in state (2) and they would cancel out in evaluating availability change of the process moving from state (1) to state (2). In that case availability is defined according to Eq. (1.7).

## 2- AVAILABILITY ANALYSIS OF PLANT 5 AND PLANT 6

### 2.1. Determination of Enthalpy and Entropy of Petroleum Fractions and Refinery Gases

In our analysis, enthalpy and entropy values of petroleum fractions must be determined first in order to carry out availability calculations for Plant 5 and Plant 6. For this purpose generalized correlations are used. Given the temperature, pressure, Watson characterization factor and the °API of the petroleum fractions, enthalpy, entropy and thus availability can be calculated. The enthalpy values were supplied by IPRAS. But since entropy values were not available, the same heat capacity correlations were used to calculate both enthalpy and entropy, thus providing thermodynamic consistency in the calculations.

#### 2.1.1 Determination of Specific Heat

##### 2.1.1.1 Specific Heat of the Petroleum Fractions

In 1933 Watson (26) proposed a correlation for the specific heat of petroleum fractions in both the liquid and vapor states. For the liquid state,

$$C_p = (0.055K_w + 0.35) \left( (0.6811 - 0.308SG) + 10^{-4} (T - 460) (8.15 - 3.06SG) \right) \quad (2.1)$$

where,

$C_p$  = Specific heat of liquid petroleum fractions, in Btu/lbm,

SG = Specific gravity at 60/60°F

T= Temperature, °R

$K_w$ =Watson characterization factor (=Mean average boiling point, °R)<sup>1/3</sup>/SG),

For the vapor state;

$$C_p = \frac{4.0 - SG}{6450} (T + 210) (0.12K_w - 0.41) \quad (2.2)$$

where  $C_p$  is the specific heat of the vapor petroleum fractions, in Btu/lbm.  $K_w$  is also called "UOPK" and  $K_w$  values for each petroleum fractions were taken from IPRAŞ.

The specific gravity (SG) is calculated from °API:

$$SG = \frac{141.5}{131.5 + °API} \quad (2.3)$$

### 2.1.1.2 Specific Heat of Refinery Gases

Refinery gases consist of organic and inorganic components. Organic components are methane, ethane, propane and butane; inorganic components are nitrogen, oxygen, hydrogen and hydrogen sulfide. Compositions of the refinery gases in Plant 5 and 6 are given in TABLES A.1.2. and A.2.2. (see APPENDICES 1 and 2), respectively. The following heat capacity equations were used for organic and inorganic gases respectively,

$$C_p = \alpha + \beta T + \gamma T^2 \quad (\text{organic gases}) \quad (2.4)$$

$$C_p = a + bT + cT^{-2} \quad (\text{inorganic gases}) \quad (2.5)$$

where  $C_p$  is the molar heat capacity in Btu/lbmol<sup>o</sup>F and  $T$  is temperature in K. Constants of these equations are listed in TABLES A.1.3 and A.1.4 (See APPENDIX 1).

### 2.1.2 Enthalpy and Entropy of Petroleum Fractions

The enthalpy and entropy changes in Eq. (1.7a) can be expressed as functions of temperature and pressure.

$$\Delta H_{O-1} = \int_{T_0}^{T_1} C_p dT + \int_{P_0}^{P_1} (V - T \left(\frac{\partial V}{\partial T}\right)_P) dP \quad (2.6)$$

$$\Delta S_{O-1} = \int_{T_0}^{T_1} \frac{C_p}{T} dt + \int_{P_0}^{P_1} -\left(\frac{\partial V}{\partial T}\right)_P dp \quad (2.7)$$

The first terms on the right hand sides of both of these equations show the temperature effects. They will be denoted here by  $\Delta H_T$  and  $\Delta S_T$ , respectively:

$$\Delta H_{O-1,T} = \int_{T_0}^{T_1} C_p dt \quad (2.8)$$

$$\Delta S_{O-1,T} = \int_{T_0}^{T_1} \frac{C_p}{T} dt \quad (2.9)$$

The second terms in Eqs (2.6) and (2.7) give the pressure effects. They will be denoted here by  $\Delta H_p$  and  $\Delta S_p$ , respectively:

$$\Delta H_{O-1,p} = \int_{P_0}^{P_1} (V - T \left(\frac{\partial V}{\partial T}\right)_P) dP \quad (2.10)$$

$$\Delta S_{O-1,P} = \int_{P_0}^{P_1} - \left( \frac{\partial V}{\partial T} \right)_P dP \quad (2.11)$$

If the Liquid phase can be assumed to be pressure independent, pressure effect term may be neglected. But during this study, the pressure effect, although approximately, was taken into account. The pressure effect on liquid enthalpy was approximated by:

$$\Delta H_{O-1,P} = (V_{\text{cons}} - T_{\text{av}} \frac{V_{\text{cons}}}{T_{\text{cons}}}) \Delta P$$

or

$$\Delta H_{O-1,P} = \frac{1}{\rho_{\text{cons}}} \left( 1 - \frac{T_{\text{av}}}{T_{\text{cons}}} \right) \Delta P \quad (2.12)$$

where  $T_{\text{av}}$  is taken as the mean of the reference state temperature and the operating temperature of the stream,  $\rho_{\text{cons}}$  is taken as the density of petroleum fractions at 288K and  $T_{\text{cons}}$  is taken as 288K. The pressure effect on liquid entropy was approximated by:

$$\Delta S_{O-1,P} = - \frac{\Delta P}{\rho_{\text{cons}} T_{\text{cons}}} \quad (2.13)$$

In both Eqs. (2.12) and (2.13),  $\Delta P$  is  $P_1 - P_0$

### 2.1.3 Enthalpy and Entropy Changes due to Mixing

Crude oil is fractionated into various refinery products in Plant 5. The mixing effect must be considered for the separation units such as atmospheric distillation column and vacuum tower. Enthalpy of mixing was taken as zero because of ideal solution assumption. The entropy of mixing in an ideal solution can be calculated by:

$$\Delta S_{\text{mix}} = -R \sum x_i \ln x_i \quad (2.14)$$

#### 2.1.4 Enthalpy and Entropy Changes in the Atmospheric Overhead Vapor

Total enthalpy and entropy changes of the atmospheric overhead vapor containing overhead gas, LSRN and steam were calculated with respect to the same mixture at the environment temperature  $T_0$  and pressure  $P_0$ . In the calculations, ideal gas assumption was made. The temperature effect on the enthalpy is given as:

$$\Delta H_{0-1,T} = \int_{T_0}^T \sum_i^m y_i C_{p_i} dT$$

where  $y_i$  represents mole fraction in the gas phase. Since the pressure effect and the mixing effect on enthalpy change for an ideal gas mixture are each equal to zero, total enthalpy change can be written as:

$$\Delta H_{0-1} = \int_{T_0}^T \sum_i^m y_i C_{p_i} dT \quad (2.15)$$

The temperature effect on the entropy change is given as:

$$\Delta S_{0-1,T} = \int_{T_0}^T \sum_i^m y_i \frac{C_{p_i}}{T} dT \quad (2.16)$$

The pressure effect on the entropy is given as:

$$\Delta S_{0-1,p} = -R \ln \frac{P_1}{P_0} \quad (2.17)$$

If Eqs. (2.16) and (2.17) are combined, the total entropy change can be written as:

$$\Delta S_{O-1} = \int_{T_0}^{T_1} \sum_i^m Y_i \frac{p_i}{T} dT - R \ln \frac{P_1}{P_0} \quad (2.18)$$

## 2.2 Calculation of Availability of a Stream.

The availability of a stream at the operating conditions of  $T_1$  and  $P_1$  (state 1) is calculated by Eq. (1.7a) for a chemically nonreacting system and by Eq. (1.11) for a chemically reacting system. In addition, availability change for a separation system where ideal solution assumption is made ( $\Delta H_{sep} = 0$ ) in Eq. (1.9), is obtained as follows

$$\Delta S_{sep} = -\Delta S_{mix} = R \sum_i^m x_i \ln x_i \quad (2.19)$$

$$\Delta A_{v, sep} = -RT_0 \sum_i^m x_i \ln x_i \quad (2.20)$$

On the other hand, availability change for a mixing process is given by:

$$\Delta A_{v, mix} = -\Delta A_{v, sep} = RT_0 \sum_i^m x_i \ln x_i \quad (2.20a)$$

## 2.3 Available Energy loss:

A chemical process, in general, may be simple or highly complex. Any chemical process has as its goal the conversion of raw materials into useful products. In the case of oil refineries, crude oil is fractionated into refinery products. In order to achieve the fractionation, an amount of work must be supplied to the system. Work may be supplied in the form of shaft work or an equivalent amount of heat at any temperature. Therefore, some form of work is required to perform the transformation from

initial to desired final conditions. In any process requiring work, there is a minimum amount of work which must be supplied to ensure the desired change from inlet to outlet conditions. This work is called the ideal work requirement. Any real process will require a greater amount of work than the ideal work because all actual processes are irreversible and any irreversibility results in lost work. For a real process lost work can be calculated for different pieces of equipment and then summed up to determine the total lost work. Processes may be analyzed to see what part of the actual work is lost in each equipment. Availability analysis is the best way to pinpoint lost work through processing steps as pointed out in literature (2)

Available energy loss or the lost work concept is described in literature. The destruction of availability is due to entropy increase (4). In other words, loss of work output or extra input is related to the entropy creation (12). Thus loss of available energy is called wasted work (6). The loss of available energy for each equipment can be calculated by summing up the availabilities of the inlet streams and sources and subtracting the sum of the availabilities of the outlet streams:

$$\Delta A_{V, \text{loss}} = \sum A_{V, \text{inlet streams and sources}} - \sum A_{V, \text{outlet streams}} \quad (2.21)$$

The above equation does not distinguish an outlet stream which is used downstream from one which is purged. Therefore the following equation should be preferred.

$$\Delta A_{V, \text{loss}} = \sum_{\substack{\text{all} \\ \text{inlet} \\ \text{streams} \\ \text{and} \\ \text{sources}}} A_V - \sum_{\substack{\text{all usable} \\ \text{outlet} \\ \text{streams}}} A_V \quad (2.22)$$

The total availability loss is the summation of individual availability losses of the equipment.

#### 2.4 Availability Efficiency ( $\eta_{A_V}$ )

Availability efficiency may be defined simply as the ratio of the outlet availability to the inlet availability. But some of the outlet availability is practically unrecoverable and therefore discarded. This definition is not appropriate for each of the process units. A more general definition could be made as (5):

$$\eta_{A_V} = \frac{\sum_{\substack{\text{utility} \\ \text{generated}}} A_V + \sum_{\substack{\text{streams other than} \\ \text{source streams and purge streams}}} \Delta A_V}{\sum_{\substack{\text{utility} \\ \text{supplied}}} A_V - \sum_{\substack{\text{streams which act as} \\ \text{availability source}}} \Delta A_V} \quad (2.23)$$

Utility generated and utility supplied could be heat, electricity generated or supplied. Streams other than source streams and purge streams differ from equipment to equipment. For example in a heat exchanger, cold stream represents the stream which is neither source or purge stream. Again in a heat exchanger hot stream represents the stream which acts as the availability source because it transfers some of its available energy to the cold

stream

#### 2.4.1 Heat Exchanger

The main purpose of a heat exchanger is to transfer availability from one stream to another. The hot stream provides the availability needed. Then Eq. (2.23) can be written for a heat exchanger (5),

$$\eta_{A_v} = \frac{\Delta A_v \text{ cold stream}}{-\Delta A_v \text{ hot stream}} \quad (2.24)$$

#### 2.4.2 Furnace

None of the streams provides any availability.

Availability change of a stream is provided by fuel supplied to the system. Then eq. (2.23) becomes (5):

$$\eta_{A_v} = \frac{\Delta A_v \text{ streams}}{A_{v \text{ supp}}} \quad (2.25)$$

where  $A_{v \text{ supp}}$  is calculated from fuel supplied. In our analysis, heat supplied to the furnaces was taken from IPRAŞ. Carnot equivalent work, i.e. availability supplied, was calculated by:

$$A_{v \text{ supp}} = Q_H \left(1 - \frac{T_O}{T_H}\right) \quad (2.26)$$

where  $Q_H$  is the heat supplied to the furnace, in kJ/hr,  $T_H$  and  $T_O$  are the furnace and reference temperature, respectively.  $A_{v \text{ supp}}$  is listed for each of the furnace in Plant 5 and Plant 6 in TABLES A.1.6 and A.2.5 (see APPENDICES 1 and 2) respectively.

#### 2.4.3 Pump

Availability efficiency for a pump is written

from Eq. (2.23) as;

$$\eta_{A_V} = \frac{\dot{A}_{V \text{ stream}}}{A_{V \text{ supp}}} \quad (2.27)$$

where  $A_{V \text{ supp}}$  is the work supplied to the system and calculated by (Assuming electricity is used with 100% efficiency)

$$A_{V \text{ supp}} = \frac{V \cdot \Delta P}{\eta_{\text{mech}}} \quad (2.28)$$

where  $V$  is the volume of a stream and  $\Delta P$  is the difference between discharge pressure and suction pressure,  $\eta_{\text{mech}}$  is the mechanical efficiency taken from İPRAŞ.  $A_{V \text{ supp}}$  of each pump for Plant 5 and Plant 6 are listed in TABLES A.1.5 and A.2.5. (see APPENDICES 1 and 2),

#### 2.4.4 Separator

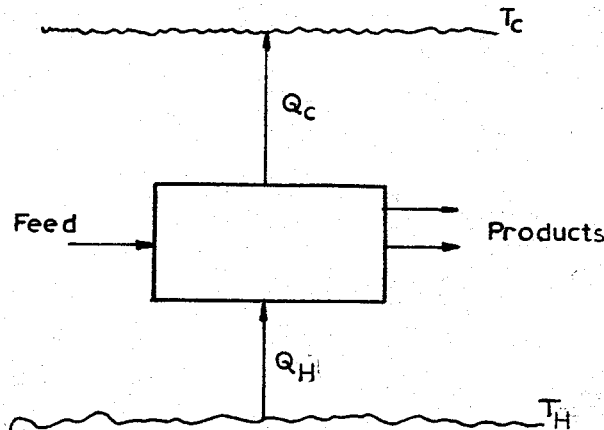

Figure 2.1.A separator

The process is driven by heat  $Q_H$  entering the system at a temperature  $T_H$ . An amount of heat  $Q_C$  leaves the system at a temperature  $T_C$ . If  $Q_H$  were supplied to a reversible heat engine rejecting heat at  $T_O$ , an amount of work equal to  $Q_H \left( \frac{T_H - T_O}{T_H} \right)$  could be obtained. Similarly, an

amount of work equal to  $Q_c \left( \frac{T_c - T_o}{T_c} \right)$  could be obtained from  $Q_c$ . Therefore, the minimum amount of work which must ensure separation is given by:

$$W_{\min} = Q_H \left( \frac{T_H - T_o}{T_H} \right) - Q_c \left( \frac{T_c - T_o}{T_c} \right) \quad (2.29)$$

Here  $W_{\min}$  is equivalent to  $A_{V, \text{sum}}$ . Then the availability efficiency by Eq. 2.23 can be written for a separator as (5)

$$\eta_{AV} = \frac{\Sigma A_V \text{ all usable outlet} - \Sigma A_V \text{ all inlet}}{Q_H \left( 1 - \frac{T_o}{T_H} \right) - Q_c \left( 1 - \frac{T_o}{T_c} \right)} \quad (2.30)$$

However, if main part of the heat is supplied to the feed of the distillation column in the furnace and if there is no reboiler or condenser in the conventional sense, as in our case, then Eq. (2.30) should not be used.

### 3- RESULTS AND DISCUSSION

#### 3.1 Plant 5 (See Fig. 3.1)

Almost every unit of the overall process was analysed in order to determine the availability of each stream, the loss of available energy in each equipment and to calculate the availability efficiency. The symbols corresponding to various units are defined in TABLE 3.1.1

Enthalpies, entropies and availabilities of the stream entering and leaving the units were calculated by using properties of streams given in TABLE A.1.1 (see APPENDIX 1). Results for each unit are listed in TABLES A.3.1-A.3.13 (See APPENDIX 3). In the availability calculations, it was observed that the magnitude of availability varied most with changes in temperature. It varied least with changes in pressure and slightly changed with  $K_w$ .

It was observed that in the distillation column (5C-2), in the stripper (5C-3), in the atmospheric overhead drum (5C-4) and in the debutanizer overhead drum (5C-6), availability of outlet streams decrease because the available energy degrades through the process. In the furnaces, 5F-1, 5F-3, 5F-101 (See TABLE A.3.9) and in the debutanizer column, 5C-5, (see TABLE A.3.6) availability of the outlet streams increase because heat is supplied to these systems (see TABLE A.1.6). Also an increase occurs in the outlet

availability of overall plant 5 (see TABLE A.3.13)

The availability analysis results given in APPENDIX 3 are summarized in TABLE 3.1.2. In addition, availability losses and availability efficiencies of units are presented. The loss of available energy is defined by summing up the availabilities of the inlet streams and energy input, and then subtracting from it the sum of the availabilities of the outlet streams. Crude oil is a mixture and is fractionated into certain refinery products in atmospheric and vacuum distillation towers. Therefore, availability change due to separation must be calculated for these separation units and overall plant 5. The calculation of separation availability change for distillation column and overall Plant 5 is shown in examples presented in APPENDIX 5.

Availability efficiency expression given by Eq. 2.30 for a separation process could not be applied to the atmospheric distillation column because of steam addition directly into the column and addition of heat mainly in the furnaces. In addition, there is no reboiler and condenser in the distillation column and heat is removed in the heat exchanger train. Therefore, instead the availability ratio was used in this case. It is the ratio of the outlet (O) availability to the inlet (I) availability. Availability ratio was also calculated for other separation units such as stripper (5C-3), atmospheric overhead drum (5C-4) debutanizer overhead drum (5C-6), vacuum tower (5C-101).

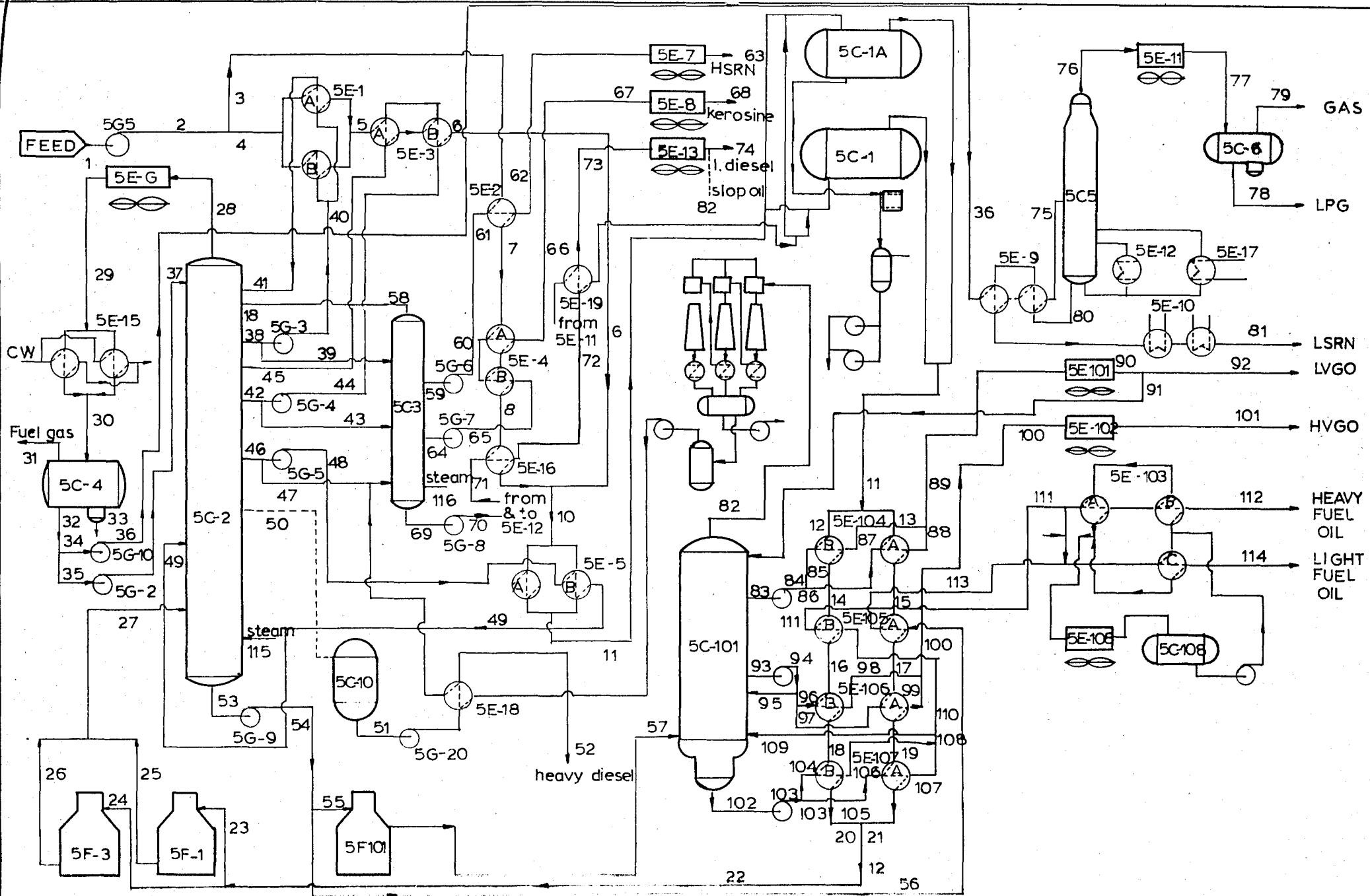

Fig.31 Flow Sheet of plant 5

TABLE 3.1.1 UNIT SYMBOLS<sup>x</sup> AND MEANINGS IN PLANT 5 AND PLANT 6

COLUMNS and DRUMS	HEAT		AIR COOLERS	WATER COOLERS	PUMPS	PUMPS
	FURNACES	EXCHANGERS				
5C-1A, 5C-1 Desalters	5F-1	5E-1	5E-6	5E-10	5G-1	5G-20
5C-2 Atm. Distillation Column	5F-3	5E-2	5E-7	5E-15	5G-2	5G-101
5C-3, 6C-A, 6C-5 Stripper	5F-101	5E-3	5E-8	5E-103	5G-3	5G-102
5C-4 Atm. O/H Drum	6F-1	5E-4	5E-11	6E-2	5G-4	5G-104
5C-5, 6C-105 Debutanizer	6F-2	5E-16	5E-13	6E-4	5G-5	6G-1
5C-6, 6C-106 Debutanizer O/H Drum	6F-101	5E-104	5E-101	6E-103	5G-6	6K-1, 6K-101
5C-101 Vacuum Distillation Column	6F-102	5E-105	5E-102	6E-105	5G-7	6G-2, 6G-3
6C-1, 101, 102, 103, Reactor	6F-103	5E-106, 5E-107		6E-102	5G-8	6G-102
6C-3 Drum	6F-104	6E-1, 6E-3			5G-9	6G-103
6C-2, 6C-104 Separator		6E-101, 6E-104			5G-10	6G-104

<sup>x</sup>5 indicates Plant 5; 6 indicates Plant 6

BOĞAZICI ÜNİVERSİTESİ KÜTÜPHANASI

TABLE 3.1.2 SUMMARY OF AVAILABILITY<sup>x</sup> ANALYSIS OF EACH UNIT IN PLANT 5

UNIT	$\Sigma A_v \times 10^{-5}$ Inlet Streams	$\Sigma A_v \times 10^{-5}$ Outlet Streams	$\Delta A_{vsep} \times 10^{-5}$	$\Delta A_{v supp} \times 10^{-5}$	$\eta A_v$ (%)	Availability O/I (%)	$\Sigma A_v \times 10^{-5}$ Total Inlet	$\Sigma A_v \times 10^{-5}$ Total Outlet	$\Delta A_v \times 10^{-5}$ Loss
5C-2 (TABLE A.3.1)	1647	1481	118.0	-	-	97.09	1647	1599	48.00
5C-2 and <sup>xx</sup> 5F-1 and 5F-3 (TABLE A.3.2)	708.2	1047	118.0	2135	24.33	-	-	-	-
5C-101 (TABLE A.3.3)	1204	1063	18.38	-	-	89.81	1204	1081	123.0
5C-101 and 5F-101 <sup>xxx</sup> (TABLE A.3.4)	915.6	1063	18.38	658.5	25.17	-	-	-	-
5C-3 (TABLE A.3.5)	227.0	219.8	-	-	-	96.82	227.0	219.8	7.200
5C-4 (TABLE A.3.8)	3.875	2.825	-	-	-	-	3.875	2.825	1.050
5C-6 (TABLE A.3.7)	4.787	3.775	-	-	-	-	4.787	3.775	1.012
5F-1 (TABLE A.3.9)	409.5	921.3	-	1297	-	-	1706.5	921.3	785.2
5F-3 (TABLE A.3.9)	265.9	617.6	-	837.3	-	-	1103	617.6	485.6

x Availability unit used here is kJ/hr

xx A combined system shown in Fig. A.3.2; see APPENDIX 5 for  $\Delta A_{v gen}$  and  $\Delta A_{v sep}$  values

xxx A combined system shown in Fig. A.3.4;

$$xxxx \Delta A_{v loss} = \Sigma A_v \text{ inlet stream} - \Sigma A_v \text{ Outlet stream} - \Delta A_{v sep} + \Sigma A_{v supp}$$

TABLE 3.1.2 CONT'D

UNIT	$\Sigma A_V \times 10^{-5}$ inlet streams	$\Sigma A_V \times 10^{-5}$ outlet streams	$A_{V\text{supp}} \times 10^{-5}$	$nA_V$ (%)	$\Sigma A_V \times 10^{-5}$ total inlet	$\Sigma A_V \times 10^{-5}$ total outlet	$\Delta A_V \times 10^{-5}$ xxxx
5F-101	613.6	902.1	658.5	45.33	1272	902.1	369.9
5F-1 (TABLE A.3.10)	11.58	29.27	63.80	27.73	92.84	46.73	46.11
5E-2	5.278	11.17	24.71	←	33.75	14.94	18.81
5E-3	29.27	74.23	93.17	-	140.5	92.26	48.24
5E-4	11.17	36.02	60.49	-	78.19	42.55	35.64
5E-16 (TABLE A.3.11)	36.02	47.82	20.07	-	94.64	86.37	8.270
5E-104A	143.1	20.31	62.62	-	287.4	284.8	2.600
5E-105B	203.1	26.22	62.45	-	395.4	392.0	3.400
5E-106A	262.2	29.40	34.84	-	323.8	320.0	3.800
5E-104B	65.23	82.15	28.93	-	137.4	125.3	12.10
5E-105A	82.15	134.9	92.75	-	253.1	213.0	40.10

---

Hot stream provides availability needed in the heat exchanger

TABLE 3.1.2 CONT'D

UNIT	$\Sigma A_V \times 10^{-5}$ inlet streams	$\Sigma A_V \times 10^{-5}$ outlet streams	$\Sigma A_V \text{supp} \times 10^{-5}$	$\eta A_V$ (%)	$\Sigma A_V \times 10^{-5}$ total inlet	$\Sigma A_V \times 10^{-5}$ total outlet	$\Delta A_V \times 10^{-5}$ loss
5E-106B	134.9	165.8	34.84	--	196.5	192.6	3.900
5E-107A	294.0	436.2	150.4	--	522.2	514.1	8.100
5E-107-B	165.8	229.5	81.28	--	394.0	376.5	17.50
5G-1 (TABLE A.3.12)	1.382	16.92	23.45	--	24.84	16.92	7.920
5G-2	1.045	2.583	2.501	--	3.546	2.538	0.963
5G-3	82.38	83.33	1.663	--	84.04	83.33	0.710
5G-4	111.2	111.5	0.9507	--	112.1	111.5	0.600
5G-5	143.5	143.7	0.3682	--	143.9	143.7	0.200
5G-6	61.74	61.98	0.7820	30.69	62.52	61.98	0.540
5G-7	77.76	78.14	0.8767	--	78.64	78.14	0.500

TABLE 3.1.2 CONT'D

UNIT	$\Sigma A_v \times 10^{-5}$ Inlet streams	$\Sigma A_v \times 10^{-5}$ Outlet streams	$\Delta A_{v\text{supp}} \times 10^{-5}$	$\eta A_v$ (%)	$\Sigma A_v \times 10^{-5}$ Total inlet	$\Sigma A_v \times 10^{-5}$ Total outlet	$\Delta A_v \times 10^{-5}$ <sup>XXXX</sup> loss
5G-8	72.82	73.41	1.757	-	74.58	73.41	1.170
5G-9	801.1	802.81	4.132	-	805.2	802.81	2.390
5G-10	0.530	1.034	1.492	-	2.022	1.034	0.988
5G-20	24.82	24.91	0.190	-	25.01	24.91	0.100
5G-101	214.3	216.2	5.234	-	219.5	216.2	3.300
5G-102	382.9	383.9	3.569	28.02	386.5	383.9	2.600
5G-104	455.5	456.5	3.391	-	458.9	456.5	2.400

The availability losses of air coolers and water coolers calculated are shown in TABLE 3.1.3. In addition, TABLE 3.1.4 was prepared to compare the availability losses in each equipment in Plant 5.

TABLE 3.1.3 AVAILABILITY LOSSES IN AIR AND WATER COOLERS

	Loss of Available Energy
Air coolers	(kJ/hr) x 10 <sup>-4</sup>
5E-6	814.4
5E-7	26.12
5E-8	50.87
5E-11	7.639
5E-13	374.0
5E-101	1193
5E-102	498.0
TOTAL	2964
WATER COOLERS	
5E-10	301.5
5E-15	21.45
5E-103A/B	1072
5E-103C	673.3
TOTAL	2068

TABLE 3.1.4 THE PERCENTAGE OF THE AVAILABILITY LOSS IN  
EACH EQUIPMENT IN PLANT 5

UNIT	LOSS OF AVAILABLE ENERGY (kJ/hr) x10 <sup>-5</sup>	% of the total availability loss
5C-2 <sup>x</sup>	48.00	1.79
5C-3 <sup>x</sup>	7.200	0.27
5C-4 <sup>x</sup>	1.050	0.04
5C-6 <sup>x</sup>	1.012	0.04
5C-101	123.0	4.59
5F-1 <sup>x</sup>	785.2	29.3
5F-3 <sup>x</sup>	485.6	18.1
5F-101 <sup>x</sup>	369.9	13.8
Heat exchangers before desalters (TABLE A.3.10)	157.0	5.86
Heat exchangers after desalters (TABLE A.3.11)	90.68	3.39
Air coolers (TABLE 3.1.3)	296.4	11.1
Water coolers TABLE 3.1.3	206.8	7.72
Pumps (TABLE 3.1.2)	24.54	0.92
Other losses <sup>xx</sup>	81.62	3.05
TOTAL LOSS	2678	

<sup>x</sup>See TABLE 3.1.2

<sup>xx</sup>due to heat losses through pipes and errors in availability estimations.

Overall availability analysis results for Plant 5 are shown in Fig. 3.2 Using Eq. (2.23) availability efficiency for Plant 5 was calculated as:

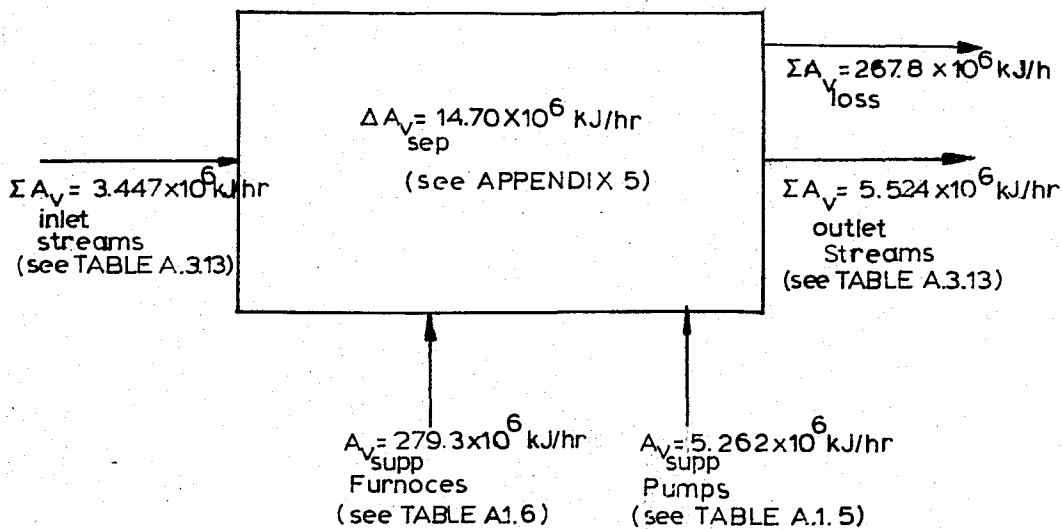

Figure 3.2 Sketch showing results of overall availability analysis for Plant 5

$$\eta_{A_V} = \frac{A_{V_{\text{output}}} - A_{V_{\text{input}}} + \Delta A_{V_{\text{sep}}}}{A_{V_{\text{sup}}(\text{furnaces})} + A_{V_{\text{sup}}(\text{pumps})}}$$

$$\eta_{A_V} = \frac{(5.524 \times 10^6 - 3.447 \times 10^6) + 14.70 \times 10^6}{279.3 \times 10^6 + 5.262 \times 10^6}$$

$$\eta_{A_V} = 5.90\%$$

This result shows that plant 5 is a highly irreversible process where large amount of availability is lost. The losses are mainly in furnaces, in heat exchangers and in

air and water coolers.

In order to make optimum use of heat exchanged between streams, usually a heat availability diagram is constructed. In this work also a sample heat availability diagram was constructed for Plant 5 (see APPENDIX 6). However, due to complexity of the process, a detailed calculation could not be made.

### 3.2. Plant 6

Plant 6 (see Fig. 3.3) was chosen to examine the concept of available energy in chemically reacting systems. There are two sections in this plant. First section is the hydrotreater. Its main purpose is to clean up heavy straight run naphta from sulfur compounds. The second section is the platformer various reactions such as hydrogenation, dehydrocyclization occur to increase octane number (ON) in this section.

The availability calculation was made only for the overall process because the data needed could be taken from IPRAŞ. From given temperature, pressure, watson K and API gravity of streams,  $A_{v_{o-1}}$  can be calculated from Eq. (1.7a). But composition of each stream must be known for the calculation of standard chemical availabilities. Composition of gas streams were taken from IPRAS and are listed in TABLE A.2.2 (See APPENDIX 2). Compositions of liquid streams, HSRN, platformate had to be estimated and structures had to be approximated, as shown in TABLE A.2.3 (See APPENDIX 2). Standart chemical availabilities of certain components could not be found in literature (22). Therefore they were calculated from standard Gibbs free energy data obtained from API Research Project 44 (1) by using Eq. (1.10).  $A_{v_o}$  for all components are listed in TABLE A.2.4 (See APPENDIX 2).

TABLE 3.2.1 AVAILABILITY CALCULATIONS FOR OVERALL PLANT 6

Stream Number	Stream Name	Flow (kg/hr)	$A_{VO}$ (kJ/kg) (Eq.1.10)	$\Delta A_{VO-1}$ (kJ/kg) (Eq.1.7a)	$A_{VO} \times 10^5$ (kJ/hr)	$\Delta A_{VO-1} \times 10^{-5}$ (kJ/hr)	$\Delta A_{Vcorr} \times 10^{-5}$ (kJ/hr) (Eq.2.20a)	$A_V^t = A_V + \Delta A_{VO-1} + \Delta A_{Vcorr}$ kJ/hr $\times 10^{-5}$
1	HSRN	30224	45694	4.8722	13811	1.4726	-5.6112	<u>13807</u>
INPUT STREAMS		TOTAL	30224					13807
19	Net gas out	296	47964	48.287	141.97	0.1429	-	142.11
29	Net gas out	1112	48849	82.189	543.20	0.9139	-	544.11
25	Gas to Ker. Desulf. Unit	1320	55677	456.94	734.94	6.0317	-	740.97
30	LPG	5941	47668	2.3475	2832.0	0.1395	-4.4519	2827.7
34	Platformate	21555	43537	2.2731	9384.4	0.4900	-5.6798	<u>9379.2</u>
OUTPUT STREAMS		TOTAL	30224					13635

x Calculation of  $\Delta A_{Vcorr}$  was shown in APPENDIX 4; here  $\Delta A_{Vcorr}$  is similar to  $\Delta A_{Vmix}$

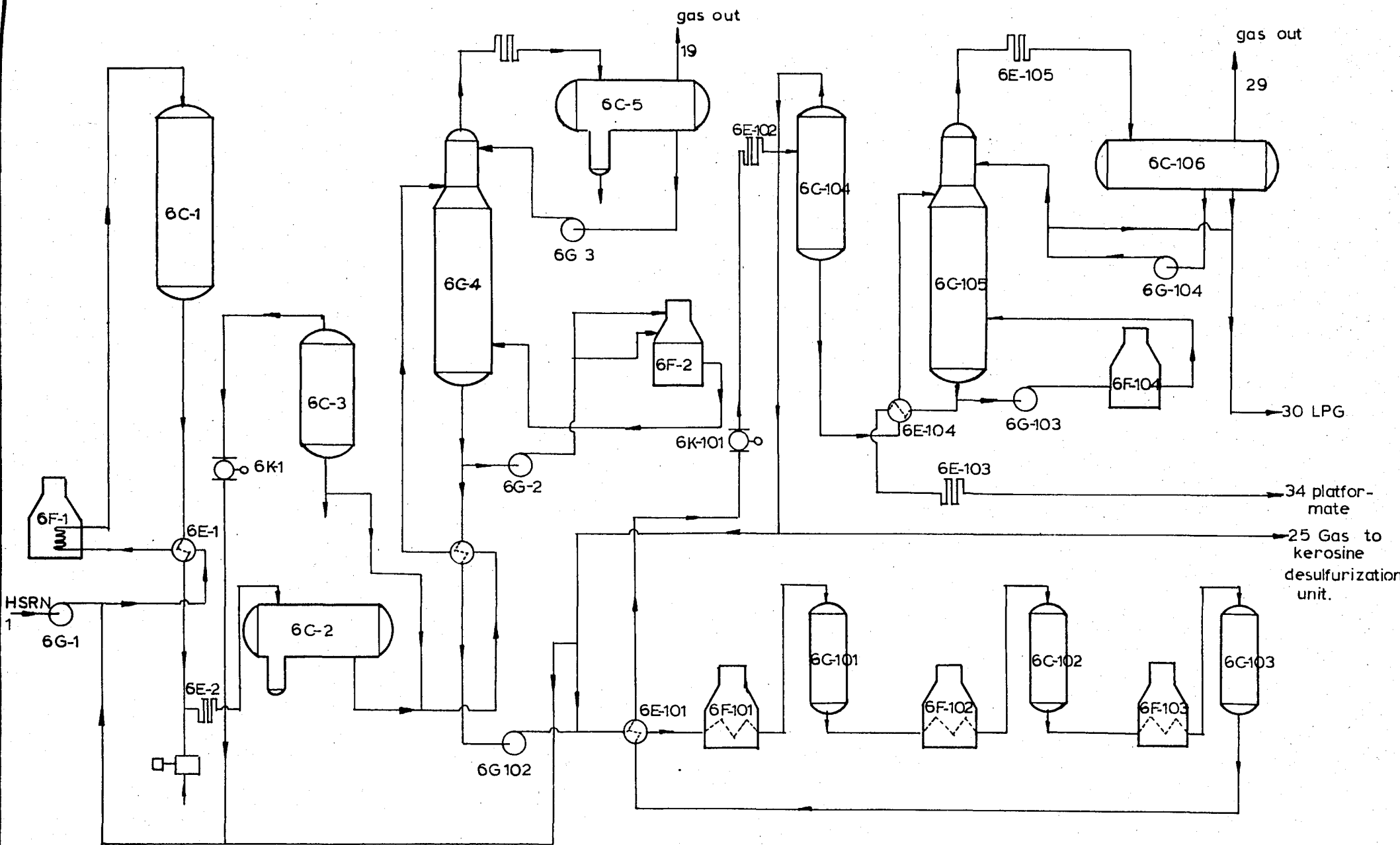

Fig. 3.3 Flow Sheet of Plant 6

Availability calculation results for streams of overall Plant 6 are given in TABLE 3.2.1 Availability calculations of gas streams are shown in TABLES A.4.1, A.4.2, A.4.3 (See APPENDIX 4). Sample availability calculations for HSRN and LPG are also shown in APPENDIX 4. Availability supplied in furnaces and through pumps is shown in TABLE A.2.5. Since availability calculation were approximate in nature in Plant 6, no further calculations were made.

#### 4. CONCLUSION AND RECOMMENDATIONS

The petroleum refineries are large consumers of energy. Thus, energy conserving and recovering techniques must be employed because of the rising energy cost. In this work detailed thermodynamic availability analysis was carried out for PLANT 5 to investigate what improvements could be made to increase the availability efficiency and to decrease loss of availability.

The primary users of energy in a petroleum refinery are furnaces. In plant 5,  $279.25 \times 10^6$  kJ/hr (see TABLE A.1.6, APPENDIX 1) of available energy is supplied by fuel and  $164.04 \times 10^6$  of kJ/hr (see furnace losses in TABLE 3.1.2) of it is lost through doors, cracks and with hot flue gases through furnaces. Thus great amount of available energy is lost by hot flue gases. In order to conserve energy, hot flue gases could be used to preheat the air coming into furnaces, to produce steam and hot water in various parts of the refinery. The heat losses in the furnaces also depend upon the conditions of the furnace linings and insulation. The design conditions could be changed to increase the efficiency of furnaces (17).

Heat input to a distillation column is required for the separation process and also for heating of the feed before entering the column. Increasing the number of trays in the column could reduce heat input into the column. However, this would necessitate an analysis,

regarding the cost of energy saved to the additional cost of new trays (17). An additional source of irreversibility which causes loss of available energy is due to the mixing of streams with nonequilibrium compositions and temperatures. Other modifications that could be done on a distillation column to reduce irreversibilities and heat input, thus decrease available energy consumption are lowering of external reflux ratio (6).

As seen in Plant 5 layout, air and water coolers are used to reduce temperatures of streams. Thus a large amount of availability is dissipated. The use of air and water coolers involve both an initial capital investment and a continuous operating cost. But the use of heat exchangers to provide heat integration requires only initial capital investment because one stream is heated and another stream is cooled without using any additional cooling air or water as in air and water coolers.

Crude enters to the system at atmospheric temperature and pressure. It is heated in crude preheat exchanger train and furnaces. In Plant 5, 5.86% of total availability loss is in heat exchangers before desalters and 3.39% of total availability loss is in the heat exchanger train after desalters (see TABLE 3.1.4). The configuration of heat exchangers is important for the maximum availability that can be transferred to the crude oil. The design of heat exchanger system and

determination of the optimum amount of heat exchange surface is a complex problem. There is also unlimited number of possible configurations to choose from and only a few of these can be evaluated by hand (13). For this purpose, a detailed heat availability diagram analysis (13) should be carried out. In addition, a heat exchange network simulator program could be used to evaluate various cases (15). As a result, heat integration in Plant 5, could save considerable amount of available energy.

In addition to process modifications suggested, calculation of enthalpy and entropy changes, especially, for pressure effect should be improved by using proper equations of state for gases and liquids. However, use of an equation of state requires computer use for the calculations of enthalpy and entropy changes and thus availability.

LIST OF REFERENCES

1. API Research Project 44
2. Brainard, J.A., "The Application of an Availability Analysis to a Direct Liquefaction Process", American Institute of Chemical Engineers, 72nd Annual Meeting, Nov. 25-29, 1979
3. Cheng, W.B., Ikumi, S., Wen, C.Y., "Entropies of Coals and Reference States in Coal Gasification Availability Analysis", AICHE 73rd Annual Meeting, Chicago, Nov. 1980
4. DeNeverse, N., Seader, J.D., "Mechanical Lost Work, Thermodynamic Lost Work and Thermodynamic Efficiencies of Processes", AICHE 86th National Meeting, Houston Texas, April 1-5, 1979
5. Dincer, S., "Thermodynamic Availability Analysis", personal communication.
6. Fitzmorris, R.E., Mah, R.S.H., "Improving Distillation Column Design Using Thermodynamic Availability Analysis", AICHE, 26, 265 (1980)
7. Gaggioli, R.A., Petit, P.J., "Use the Second Law First", Chemtech, 7, 496 (1977)

8. Gaggioli, R.A., "Second Law Analysis for Process and Energy Engineering", AIChE, Annual Meeting, Chicago, Nov. 18, 1980
9. Gaggioli, R.A., Petit, P.J., "Second Law Procedures for Evaluating Processes",
10. Gaggioli, R.A., Luis Rodriguez, S.J., "Second Law Efficiency Analysis of a Coal Gasification Process", Can.J.Chem Engg. June 1980.
11. Hanna, W.T., Frederick, W.J., "Energy Conservation in the Pulp and Paper Industries", CEP, 71, 1980
12. Haywood, R.W., "A Critical Review of the Theorems of Thermodynamic Availability with Concise Formulations", J. Mech. Eng. Sci., 16, 160 (1974)
13. Huang.F., Elshout, R., "Optimizing the Heat Recovery of Crude Units", CEP, 72, 68 (1976)
14. King, J.C., "Separation Processes", Mc Graw Hill, 1981.
15. Kleinschout, F.J., Hammer, G.A., "Exchanger Networks for Crude Units", CEP, 79, 33 (1983)

16. Ravindranath, K., Thiyagarajon, S., "Available Energy Analysis of a Sulphuric Acid Plant", Bombay-India, written communication, 1982.
17. Reay, D.A., "Industrial Energy Conservation", International Research and Development Co. Ltd. Newcastle-Upon-Tyne, England.
18. Riekert, L., "Flow and Conservation of Energy in Chemical Processing Networks", Large Chemical Plants edited by G.F. Froment, 1979.
19. Riekert, L., "Flow and loss of Available Energy in Chemical Processing Systems", Chemical Engineering in a Changing World edited by W.T. Koetsier, 483-493 (1974).
20. Riekert, L., "The Efficiency of Energy Utilization in Chemical Processes, Chem. Eng. Sci., 29, 1613 (1974).
21. Riekert, L., "The Conversion of Energy in Chemical Reactions", Energy Conversion, 15, 81-84 (1976).
22. Sussman, M.V., "Available Energy Analysis", A Manual Tufts University, 1980.

23. Smith, J.M., Van Ness, H.C., "Introduction to Chemical Engineering Thermodynamics", Mc Graw Hill, 1975.
24. Umeda, T., Itoh, J., Shirako, K., "Heat Exchange System Synthesis", CEP, 73, 70 (1978).
25. Umeda, T., Niida, K., Shirako, K., "A Thermodynamic Approach to Heat Integration in Distillation Systems", AIChE, 25, 423 (1979).
26. Watson, K.M., Nelson, E.F., "Improved Methods for Approximating Critical and Thermal Properties of Petroleum Fractions", Ind. and Eng. Chem, 25, 880 (1933).

APPENDIX 1

RAW DATA FOR PLANT 5

TABLE A.1.1. RAW DATA OF EACH STREAM IN PLANT 5 (Fig. 3.1)

Stream Number <sup>x</sup>	1	2	3	4	5	6	7
Stream Name	Crude oil	Crude oil	Crude oil	Crude oil	Crude oil	Crude oil	Crude oil
Flowrate (kg/hr)	631458	631458	199017	432441	432441	432441	199107
Density (gr/cm <sup>3</sup> )	0.8460	0.8460	0.8460	0.8460	0.8460	0.8460	0.8460
Mol Wt	210	210	210	210	210	210	210
K <sub>w</sub>	11.85	11.85	11.85	11.85	11.85	11.85	11.85
°API	35.5	35.5	35.5	35.5	35.5	35.5	35.5
SG	0.8473	0.8473	0.8473	0.8473	0.8473	0.8473	0.8473
Phase	Liquid	Liquid	Liquid	Liquid	Liquid	Liquid	Liquid
Temp (K)	303	303	303	303	335	367	329
Press (kPa)	209	2308	2308	2308	2308	2308	2308

x These numbers correspond to stream numbers in Fig. 3.1

TABLE A.1.1 CONT'D

Stream Number	8	9	10	11	12	13	14
Stream Name	Crude oil	Crude oil	Crude oil	Crude oil	Crude oil	Crude oil	Crude oil
Flow rate (kg/hr)	199017	199017	631458	631458	210486	420972	210486
Density (gr/cm <sup>3</sup> )	0.8460	0.8460	0.8460	0.8460	0.8460	0.8460	0.8460
Mol Wt	210	210	210	210	210	210	210
K <sub>w</sub>	11.85	11.85	11.85	11.85	11.85	11.85	11.85
°API	35.5	35.5	35.5	35.5	35.5	35.5	35.5
SG	0.8473	0.8473	0.8473	0.8473	0.8473	0.8473	0.8473
Phase	Liquid	Liquid	Liquid	Liquid	Liquid	Liquid	Liquid
Temp (K)	369	382	401	401	398	403	411
Press (kPa)	2308	2308	2308	363	363	363	363

TABLE A.1.1 CONT'D

Stream Number	15	16	17	18	19	20	21
Stream Name	Crude oil	Crude oil	Crude oil	Crude oil	Crude oil	Crude oil	Crude oil
Flow rate (kg/hr)	420972	210486	420972	210486	420972	210486	420972
Density (gr/cm <sup>3</sup> )	0.8460	0.8460	0.8460	0.8460	0.8460	0.8460	0.8460
Mol Wt	210	210	210	210	210	210	210
K <sub>w</sub>	11.85	11.85	11.85	11.85	11.85	11.85	11.85
°API	35.5	35.5	35.5	35.5	35.5	35.5	35.5
SG	0.8473	0.8473	0.8473	0.8473	0.8473	0.8473	0.8473
Phase	Liquid	Liquid	Liquid	Liquid	Liquid	Liquid	Liquid
Temp (K)	424	444	442	461	451	491	486
Press (kPa)	363	363	363	363	363	363	363

TABLE A.1.1 CONT'D

Stream Number	22	23	24	25	26	27	28
Stream Name	Crude oil	Crude oil	Crude oil	Crude oil	Crude oil	Crude oil	O/H gas Steam LSRN
Flow rate (kg/hr)	631458	382863	248595	382863	248595	631458	1603 3138 167893
Density (gr/cm <sup>3</sup> )	0.8460	0.8460	0.8460	0.8460	0.8460	0.8460	-
Mol Wt	210	210	210	210	210	210	-
K <sub>w</sub>	11.85	11.85	11.85	11.85	11.85	11.85	-
°API	35.5	35.5	35.5	35.5	35.5	35.5	-
SG	0.8473	0.8473	0.8473	0.8473	0.8473	0.8473	-
Phase	Liquid	Liquid	Liquid	Liquid	Liquid	Liquid	Gas
Temp (K)	489	489	489	590	595	592	374
Press (kPa)	363	363	363	363	363	363	322

TABLE A.1.1 CONT'D

Stream Number	29	30	31	32	33	34	35
Stream Name	O/H gas Steam LSRN	O/H Steam LSRN	O/H gas	Unstabilized LSRN	Sour water	Unstabilized LSRN	LSRN
Flow rate (kg/hr)	172634	172634	1603	167893	3138	56518	111375
Density (gr/cm <sup>3</sup> )	--	--	--	0.6578	1	0.6578	0.6578
Mol Wt	--	--	21.84	78	18	78	78
K <sub>w</sub>	--	--	--	12.68	--	12.68	12.68
°API	--	--	--	83.4	--	83.4	83.4
SG	--	--	--	0.6584	--	0.6584	0.6584
Phase	gas-liquid	gas-liquid	gas	Liquid	Liquid	Liquid	Liquid
Temp (K)	320	312	312	312	312	312	312
Press (kPa)	322	322	212	212	212	212	212

TABLE A.1.1 CONT'D

Stream Number	36	37	38	39	40	41	42
Stream Name	Unstabilized LSRN	LSRN	HSRN	HSPN	HSRN	HSRN	Kerosine
Flow rate (kg/hr)	56518	111375	215960	54336	161624	161624	179306
Density (gr/cm <sup>3</sup> )	0.6578	0.6578	0.7363	0.7363	0.7363	0.7363	0.7792
Mol Wt	78	78	114	114	114	114	149
K <sub>w</sub>	12.68	12.68	12.11	12.11	12.11	12.11	12.01
°API	83.4	83.4	60.5	60.5	60.5	60.5	49.9
SG	0.6584	0.6584	0.7370	0.7370	0.7370	0.7370	0.7800
Phase	Liquid	Liquid	Liquid	Liquid	Liquid	Liquid	Liquid
Temp (K)	312	312	422	422	422	353	480
Press (kPa)	1167	212	329	329	322	322	342

TABLE A.1.1 CONT'D

Stream Number	43	44	45	46	47	48	49
Stream Name	Kerosine	Kerosine	Kerosine	Light Diesel	Light Diesel	Light Diesel	Light Diesel
Flow rate (kg/hr)	71553	107753	107753	152387	68637	83750	83750
Density (gr/cm <sup>3</sup> )	0.7792	0.7792	0.7792	0.8248	0.8248	0.8248	0.8248
Mol Wt	149	149	149	216	216	216	216
K <sub>w</sub>	12.01	12.01	12.01	11.90	11.90	11.90	11.90
°API	49.9	49.9	49.9	39.9	39.9	39.9	39.9
SG	0.7800	0.7800	0.7800	0.8256	0.8256	0.8256	0.8256
Phase	Liquid	Liquid	Liquid	Liquid	Liquid	Liquid	Liquid
Temp (K)	480	480	368	540	540	540	422
Press (kPa)	342	335	335	349	349	618	342

TABLE A.1.1 CONT'D

Stream Number	50	51	52	53	54	55	56
Stream Name	Heavy Diesel	Heavy Diesel	Heavy Diesel	Reduced Crude	Reduced Crude	Reduced Crude	Reduced Crude
Flow rate (kg/hr)	11919	11919	11919	367751	367751	287365	80386
Density (gr/cm <sup>3</sup> )	0.8420	0.8420	0.8420	0.9288	0.9288	0.9288	0.9286
Mol Wt	257	257	257	393	393	393	570
K <sub>w</sub>	12.03	12.03	12.03	11.65	11.65	11.65	11.65
°API	36.4	36.4	36.4	20.7	20.7	20.7	20.7
SG	0.8428	0.8428	0.8428	0.9297	0.9297	0.9297	0.9297
Phase	Liquid	Liquid	Liquid	Liquid	Liquid	Liquid	Liquid
Temp (K)	567	567	316	585	582	582	582
Press (kPa)	356	356	961	363	1171	1171	1171

TABLE A.1.1 CONT'D

Stream Number	57	58	59	60	61	62	63
Stream Name	Reduced Crude	HC vapors Steam	HSRN	HSRN	HSRN	HSRN	HSRN
Flow rate (kg/hr)	287365	859 738	54336	54336	54336	54336	54336
Density (gr/cm <sup>3</sup> )	0.9288	-	0.7363	0.7363	0.7363	0.7363	0.7363
Mol Wt	393	95 18	114	114	114	114	114
K <sub>w</sub>	11.65	11.90 -	12.11	12.11	12.11	12.11	12.11
°API	20.7	51.90 -	60.5	60.5	60.5	60.5	60.5
SG	0.9297	0.7715 -	0.7370	0.7370	0.7370	0.7370	0.7370
Phase	Liquid	gas	Liquid	Liquid	Liquid	Liquid	Liquid
Temp (K)	646	486	486	486	423	339	318
Press (kPa)	1171	336	335.5	861	861	861	618

TABLE A.1.1 CONT'D

Stream Number	64	65	66	67	68	69	70
Stream Name	Kerosine	Kerosine	Kerosine	Kerosine	Kerosine	Light Diesel	Light Diesel
Flow rate (kg/hr)	70695	70695	70695	70695	70695	68637	68637
Density (gr/cm <sup>3</sup> )	0.7792	0.7792	0.7792	0.7792	0.7792	0.8248	0.8248
Mol Wt	149	149	149	149	149	216	216
K <sub>w</sub>	12.01	12.01	12.01	12.01	12.01	11.90	11.90
°API	49.9	49.9	49.9	49.9	49.9	39.9	39.9
SG	0.7800	0.7800	0.7800	0.7800	0.7800	0.8256	0.8256
Phase	Liquid	Liquid	Liquid	Liquid	Liquid	Liquid	Liquid
Temp (K)	472	472	358	358	318	486	486
Press (kPa)	342	832	832	832	618	349	1454

TABLE A.1.1 CONT'D

Stream Number	71	72	73	74	75	76	77
Stream Name	Light Diesel	Light Diesel	Light Diesel	Light Diesel	Unstabilized LSRN	O/H gas LPG	O/H gas LPG
Flow rate (kg/hr)	68637	68637	68637	68637	56518	5142	5142
Density (gr/cm <sup>3</sup> )	0.8248	0.8242	0.8242	0.8242	0.6578	-	-
Mol Wt	216	216	216	216	78	45.66	45.66
K <sub>w</sub>	11.90	11.90	11.90	11.90	12.68	-	-
°API	39.90	39.90	39.90	39.90	83.4	-	-
SG	0.8256	0.8256	0.8256	0.8256	0.6584	-	-
Phase	Liquid	liquid	Liquid	Liquid	liquid	Gas	Gas
Temp (K)	465	432	-	316	389	335	320
Press (kPa)	1454	1454	1454	618	832	749	749

TABLE A.1.1 CONT'D

Stream Number	78	79	80	81	82	83	84
Stream Name	LPG	O/H gas	LSRN	LSRN	Slop oil	LVGO	LVGO
Flow rate (kg/hr)	4484	657	51376	51376	8040	236263	236263
Density (gr/cm <sup>3</sup> )	-	-	0.6578	0.6578	-	0.8390	0.8390
Mol Wt	47.692	35.3876	78	78	135	250	250
K <sub>w</sub>	-	-	12.68	12.68	11.90	12.07	12.07
°API	-	-	83.4	83.4	51.1	37.0	37.0
SG	-	-	0.6584	0.6584	0.7749	0.8398	0.8398
Phase	gas	gas	Liquid	Liquid	gas	Liquid	Liquid
Temp (K)	320	320	427	310	400	472	472
Press (kPa)	517	517	749	618	14.6	41.3	1003

TABLE A.1.1 CONT'D

Stream Number	85	86	87	88	89	90	91
Stream Name	LVGO	LVGO	LVGO	LVGO	LVGO	LVGO	LVGO
Flow rate (kg/hr)	78754	157509	78254	157509	236263	236263	171406
Density (gr/cm <sup>3</sup> )	0.8390	0.8390	0.8390	0.8390	0.8390	0.8390	0.8390
Mol Wt	250	250	250	250	250	250	250
K <sub>w</sub>	12.07	12.07	12.07	12.07	12.07	12.07	12.07
°API	37.0	37.0	37.0	37.0	37.0	37.0	37.0
SG	0.8398	0.8398	0.8398	0.8398	0.8398	0.8398	0.8398
Phase	Liquid	Liquid	Liquid	Liquid	Liquid	Liquid	Liquid
Temp (K)	472	472	431	427	428	348	348
Press (kPa)	1003	1003	1003	1003	1003	618	517

TABLE A.1.1 CONT'D

Stream Number	92	93	94	95	96	97	98
Stream Name	LVGO	HVGO	HVGO	HVGO	HVGO	HVGO	HVGO
Flow rate (kg/hr)	64858	190682	190682	129440	30621	30621	30621
Density (gr/cm <sup>3</sup> )	0.8390	0.8975	0.8975	0.8975	0.8975	0.8975	0.8975
Mol Wt	250	340	340	340	340	340	340
K <sub>w</sub>	12.07	11.78	11.78	11.78	11.78	11.78	11.78
°API	37.0	26.0	26.0	26.0	26.0	26.0	26.0
SG	0.8398	0.8984	0.8984	0.8984	0.8984	0.8984	0.8984
Phase	Liquid	Liquid	Liquid	Liquid	Liquid	Liquid	Liquid
Temp (K)	348	569	569	569	569	569	473
Press (kPa)	618	87.5	992	992	992	992	992

TABLE A.1.1 CONT'D

Stream Number	99	100	101	102	103	104	105
Stream Name	HVGO	HVGO	HVGO	Heavy Fuel oil	Heavy Fuel oil	Heavy Fuel oil	Heavy Fuel oil
Flow rate (kg/hr)	30621	61242	61242	174622	174622	87311	87311
Density (gr/cm <sup>3</sup> )	0.8975	0.8975	0.8975	0.9871	0.9871	0.9871	0.9871
Mol Wt	340	340	340	630	630	630	630
K <sub>w</sub>	11.78	11.78	11.78	11.13	11.13	11.13	11.13
°API	26.0	26.0	26.0	11.7	11.7	11.7	11.7
SG	0.8984	0.8984	0.8984	0.9881	0.9881	0.9881	0.9881
Phase	Liquid	Liquid	Liquid	Liquid	Liquid	Liquid	Liquid
Temp (K)	473	473	341	626	626	626	626
Press (kPa)	992	992	618	69	1418	1418	1418

TABLE A.1.1 CONT'D

Stream Number	106	107	108	109	110	111	112
Stream Name	Heavy Fuel oil	Heavy Fuel oil	Heavy Fuel oil	Heavy Fuel oil	Heavy Fuel oil	Heavy Fuel oil	Heavy Fuel oil
Flow rate (kg/hr)	87311	87311	174622	21396	153226	153226	153226
Density (gr/cm <sup>3</sup> )	0.9871	0.9871	0.9871	0.9871	0.9871	0.9871	0.9871
Mol Wt	630	630	630	630	630	630	630
K <sub>w</sub>	11.13	11.13	11.13	11.13	11.13	11.13	11.13
API	11.7	11.7	11.7	11.7	11.7	11.7	11.7
SG	0.9881	0.9881	0.9881	0.9881	0.9881	0.9881	0.9881
Phase	Liquid	Liquid	Liquid	Liquid	Liquid	Liquid	Liquid
Temp (K)	558	484	521	521	521	479	371
Press (kPa)	1418	1418	1418	1418	1418	1418	618

TABLE A.1.1 CONT'D

Stream Number	113	114	115	116
Stream Name	Light Fuel oil	Light Fuel oil	Steam	Steam
Flow rate (kg/hr)	80386	80386	2400	738
Density (gr/cm <sup>3</sup> )	0.9286	0.9286	-	-
Mol Wt	570	570	18	18
K <sub>w</sub>	11.65	11.65	-	-
°API	20.7	20.7	-	-
SG	0.9297	0.9297	-	-
Phase	Liquid	Liquid	gas	gas
Temp (K)	486	365	781	781
Press (kPa)	1171	686	398	398

TABLE A.I.2 COMPOSITIONS OF REFINERY GASES IN PLANT 5

Component	STREAM		
	31 mol %	78 mol %	79 mol %
H <sub>2</sub> S	-	1.3	3.8
H <sub>2</sub>	14	-	-
N <sub>2</sub>	16	-	4.9
CO <sub>2</sub>	-	-	0.4
CO	-	-	30.2
O <sub>2</sub>	-	-	2.4
C <sub>1</sub>	40	1.5	5.6
C <sub>2</sub>	18	9.1	12.7
C <sub>3</sub>	12	48.7	31.6
C <sub>4</sub>	-	39.4	8.4

TABLE A.1.3 CONSTANTS OF MOLAR HEAT CAPACITIES OF INORGANIC GASES;  $C_p = a + bT + cT^{-2}$

$C_p(22)$ : Btu/(lbmol) ( $^{\circ}$ F) or cal/(gmol) ( $^{\circ}$ C); T:K

Component	a	$b \times 10^3$	$c \times 10^{-5}$
H <sub>2</sub> O	7.30	2.46	0.00
H <sub>2</sub> S	7.81	2.96	-0.46
H <sub>2</sub>	6.52	0.78	0.12
N <sub>2</sub>	6.83	0.90	-0.12
O <sub>2</sub>	7.16	1.00	-0.40
CO	6.79	0.98	-2.06

TABLE A.1.4 CONSTANTS OF MOLAR HEAT CAPACITIES OF ORGANIC GASES;  $C_p = \alpha + \beta T + \gamma T^2$

$C_p(22)$ : Btu/(lbmol) ( $^{\circ}$ F) or cal/(gmol) ( $^{\circ}$ C); T:K

Component	$\alpha$	$\beta \times 10^3$	$\gamma \times 10^6$
CH <sub>4</sub>	3.381	18.044	-4.300
C <sub>2</sub> H <sub>6</sub>	2.247	38.201	-11.049
C <sub>3</sub> H <sub>8</sub>	2.410	57.195	-17.533
C <sub>4</sub> H <sub>10</sub>	3.844	73.350	-22.655
C <sub>5</sub> H <sub>12</sub>	4.895	90.113	-28.039
C <sub>6</sub> H <sub>14</sub>	6.011	106.746	-33.363
C <sub>8</sub> H <sub>18</sub>	8.163	140.217	-44.217
C <sub>6</sub> H <sub>12</sub>	-7.701	125.675	-41.584
C <sub>7</sub> H <sub>8</sub>	0.576	93.493	-31.227

TABLE A.1.5 AVAILABILITY SUPPLIED TO THE PUMPS IN PLANT 5

Pumps	$V(m^3/hr)$	$\Delta P(kPa)^x$	$W_s = V \cdot \Delta P$ (kJ/hr)	$\eta_{mech}^{xx}$ (%)	$A_{V\text{supp}}$ (kJ/hr) (Eq. 2.28)	Pumps	$V(m^3/hr)$	$\Delta P(kPa)^x$	$W_s = V \cdot \Delta P$ (kJ/hr)	$\eta_{mech}^{xx}$ (%)	$A_{V\text{supp}}$ (kJ/hr) (Eq. 2.28)
5G-1	745.70	2200.3	1641996	0.7	2345709	5G-10	85.85	954.9	82042	0.55	149167
5G-2	169.17	915.7	155082	0.62	250132	5G-20	14.14	859.9	12170	0.64	19016
5G-3	219.32	553.27	121431	0.73	166344	5G-101	281.35	929.5	261700	0.50	523400
5G-4	138.16	343.8	47534	0.50	95068	5G-102	212.26	373.6	185580	0.52	356885
5G-5	101.45	233.9	27245	0.74	36818	5G-104	176.74	1303.6	230567	0.68	339069
5G-6	73.73	498.1	36756	0.47	78204	5G-106	81.76	4470	36645	0.70	52350
5G-7	90.64	628.2	56986	0.65	87671	5G-107	23.85	1963.7	36997	0.70	52853
5G-8	83.14	1013.5	84328	0.48	175683	5G-108	272.55	310.05	84556	0.70	120809
5G-9	395.60	803.6	318161	0.77	413196	TOTAL					5262374

x  $\Delta P$  is the difference between discharge pressure and suction pressure

xx Supplied by IPPAS

TABLE A.1.6 AVAILABILITY SUPPLIED TO THE FURNACES IN PLANT 5

Furnace	$\underline{Q_H}$ (kJ/hr)	$\underline{T_H}$ (K)	$\underline{A_v^{supp}}$ (kJ/hr) (Eq. 2.26)
5F-1	$183.87 \times 10^6$	1011	$129.67 \times 10^6$
5F-3	$119.48 \times 10^6$	996	$83.73 \times 10^6$
5F-101	$93.69 \times 10^6$	1003	$65.85 \times 10^6$
TOTAL	$397.04 \times 10^6$		$279.25 \times 10^6$

APPENDIX 2

RAW DATA FOR PLANT 6

TABLE A.2.1 RAW DATA FOR OVERALL PLANT 6 (Fig. 3.3)

Stream No	IN			OUT		
	1	19	29	30	34	25
Stream Name	HSRN	Net gas out	Net gas out	LPG	Platformate	Gas to kerosine Desulfirization Unit
Flows (kg/hr)	30224	296	1112	5941	21555	1320
Density (gr/cm <sup>3</sup> )	0.7572	-	-	0.5302	0.7677	-
Mol Wt	126.39	23.82	32.23	48.787	99.14	12.56
Temp (K)	311	311	311	311	311	336
Press (kPa)	3408	1135	1824	1824	1479	42.35
K <sub>w</sub>	12.01	-	-	14.41	11.48	-
°API	54.9	-	-	134.5	52.3	-
SG	0.7591	-	-	0.5319	0.7698	-

TABLE A.2.2 COMPOSITIONS OF REFINERY GASES IN PLANT 6

Component	Net gas out (Stream 19) mole %	Net gas out (Stream 29) mole %	Gas to Desulf. Unit (Stream 25) mole %
H <sub>2</sub> O	-	0.02	0.01
H <sub>2</sub> S	4.40	-	-
H <sub>2</sub>	33.76	13.7	64.12
CH <sub>4</sub>	24.36	17.22	15.27
C <sub>2</sub> H <sub>6</sub>	14.25	25.29	9.00
C <sub>3</sub> H <sub>8</sub>	11.16	27.16	6.73
i-C <sub>4</sub> H <sub>10</sub>	3.54	9.57	2.09
n-C <sub>4</sub> H <sub>10</sub>	3.16	6.87	1.53
i-C <sub>5</sub> H <sub>12</sub>	1.35	0.12	0.46
n-C <sub>5</sub> H <sub>12</sub>	0.71	0.05	0.23
n-C <sub>6</sub> H <sub>14</sub>	--	-	0.28
n-C <sub>8</sub> H <sub>18</sub>	1.10	-	-
C <sub>6</sub> H <sub>12</sub> (NAPHTENE)	1.10	-	-
C <sub>7</sub> H <sub>8</sub>	1.11	-	0.28

TABLE A.2.3 COMPOSITION OF LIQUID PHASES IN PLANT 6

Component	HSRN mole % (x)	LPG mole % (xx)	Platformate mole % (x)
H <sub>2</sub> O	-	0.01	-
H <sub>2</sub> S	-	0.04	-
H <sub>2</sub>	-	0.29	-
C <sub>1</sub>	-	1.82	-
C <sub>2</sub>	-	12.76	-
C <sub>3</sub>	-	34.81	-
i-C <sub>4</sub>	-	24.76	-
n-C <sub>4</sub>	-	24.27	1.00
i-C <sub>5</sub>	-	0.81	8.96
n-C <sub>5</sub>	-	0.43	6.08
C <sub>7</sub> H <sub>16</sub>	-	-	21.27
m-Xylene	-	-	62.69
C <sub>9</sub> H <sub>20</sub>	50.23	-	-
C <sub>9</sub> H <sub>18</sub>	39.46	-	-
C <sub>9</sub> H <sub>12</sub>	10.31	-	-

x mole %'s of both HSRN and Platformate were estimated.

xx mole % of LPG was supplied by IPRAS

TABLE A.2.4 STANDARD CHEMICAL AVAILABILITIES OF  
COMPONENTS IN PLANT 6 (23)

Component	Name	$A_{v_0}$ (kJ/kg-mol)
H <sub>2</sub> O (Liquid)	Water	0
H <sub>2</sub> S (gas)	Hydrogene Sulfide	504540
H <sub>2</sub> (gas)	Hydrogene	237190
C <sub>1</sub> (gas)	Methane	817971
C <sub>2</sub> (gas)	Ethane	1467452
C <sub>3</sub> (gas)	Propane	2108440
i-C <sub>4</sub> (gas)	Isobutane	2745495
n-C <sub>4</sub> (gas)	n-Butane	2747797
i-C <sub>5</sub> (gas)	2-Methyl Butane	3380417
n-C <sub>5</sub> (gas)	n-Pentane	3386860
i-C <sub>5</sub> (liquid)	2-Methyl Butane	3380041
n-C <sub>5</sub> (liquid)	n-Pentane	3385814
C <sub>7</sub> H <sub>16</sub> (liquid)	n-Heptane	4659967
C <sub>9</sub> H <sub>10</sub> (liquid)	m-Xylene	4448675
C <sub>9</sub> H <sub>20</sub> (liquid) <sup>x</sup>	n-Nonane	5946093
C <sub>9</sub> H <sub>18</sub> (liquid) <sup>x</sup>	n-Butyl Cyclo Hexane	5740534
C <sub>9</sub> H <sub>12</sub> (liquid) <sup>x</sup>	1,3,5 Trimethyl Benzene	5076483

x Calculated from standard Gibbs free energy data obtained  
from API Project 44 (1)

TABLE A.2.5 AVAILABILITY SUPPLIED TO THE FURNACES AND PUMPS  
IN PLANT 6

Furnaces	$A_{v_{supp}}$ (kJ/hr) (Eq. 2.26)	Pumps	$A_{v_{supp}}$ (kJ/hr) (Eq. 2.26)
6F-1	$4.431 \times 10^6$	6G-1	169681
6F-2	$3.882 \times 10^6$	6G-2	118889
6F-101	$15.435 \times 10^6$	6G-3	3901
6F-102	$4.241 \times 10^6$	6G-102	171787
6F-103	$0.622 \times 10^6$	6G-103	99530
6F-104	$4.431 \times 10^6$	6G-104	18878
		6K-1	38581
		6K-101	2090826
TOTAL	$33.042 \times 10^6$	TOTAL	2712073

APPENDIX 3

AVAILABILITY ANALYSIS FOR INDIVIDUAL  
UNITS IN PLANT 5

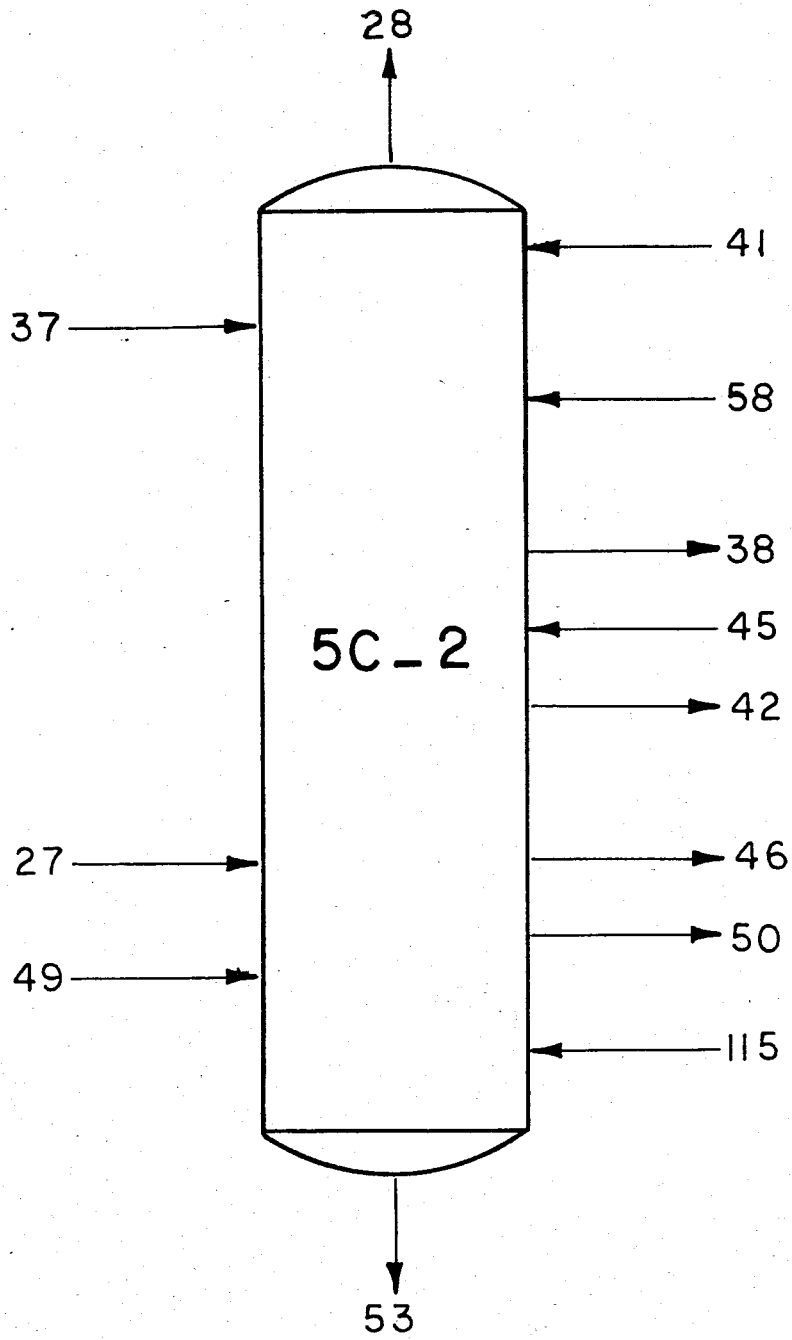

Figure A.3.1 Distillation column

TABLE A.3.1 AVAILABILITY ANALYSIS FOR ATMOSPHERIC DISTILLATION COLUMN (See Fig. A.3.1)

Stream Number	$\Delta H_T$ (kJ/kg) (Eq. 2.8)	$\Delta H_p$ (kJ/kg) (Eq. 2.12)	AH (kJ/kg) (Eq. 2.6)	$\Delta S_T$ (kJ/kgK) (Eq. 2.9)	$-\Delta S_p$ (kJ/kgK) (Eq. 2.13)	$\Delta S$ (kJ/kgK) (Eq. 2.7)	$A_v$ (kJ/hr) (Eq. 1.7a)
27	751.770	-0.1676	751.6023	1.7060	0.0011	1.7049	153786607
49	277.60	-0.0723	277.5277	0.7729	0.0010	0.7719	3978251
37	32.48	-0.0095	32.4705	0.1063	0.0006	0.1057	108245
58	1484.56	0	1484.56	3.7140	0.3120	3.402	751810
45	154.46	-0.0463	154.4137	0.4630	0.0010	0.4620	1803537
41	123.69	-0.0383	123.6517	0.3797	0.0010	0.3787	1745394
115	3394.11	0	3394.11	7.8437	-	7.8437	<u>2536050</u>
TOTAL INPUT							164709894
28	152.0466	0	152.0466	0.4529	0.1337	0.3192	9827190
38	297.88	-0.0764	297.8036	0.8294	0.0011	0.8283	11007524
42	446.97	-0.1078	446.8622	1.1543	0.0011	1.1532	18505921
46	603.79	-0.1360	603.654	1.4515	0.0010	1.4505	26119894
50	682.45	-0.1509	682.2991	1.5918	0.0010	1.5908	2482021
53	682.36	-0.1495	682.2105	1.5591	0.0010	1.5581	<u>80131729</u>
TOTAL OUTPUT							148074279

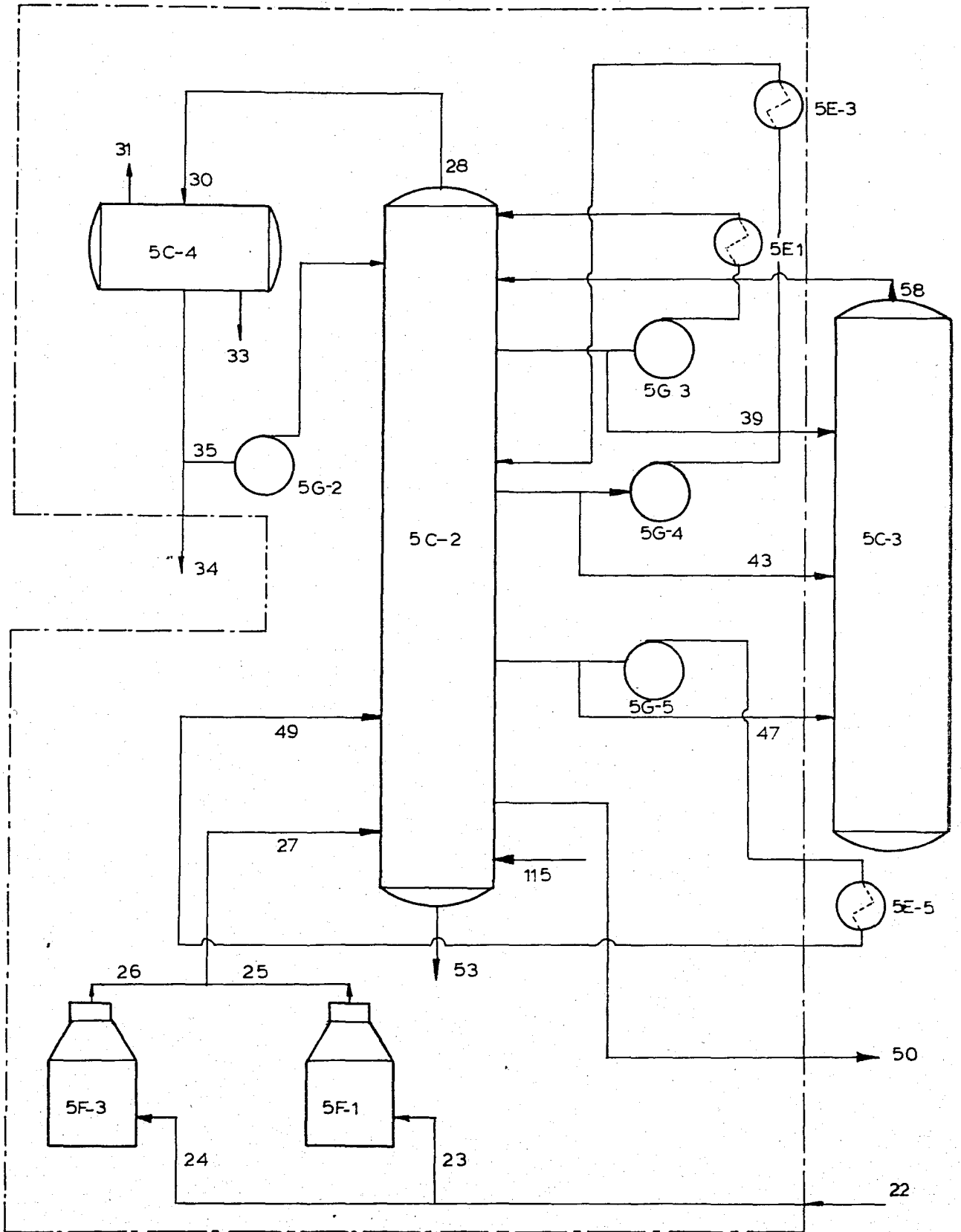

Fig. A.3.2 Combination of atmospheric distillation column and furnaces used to heat the feed.

TABLE A.3.2 AVAILABILITY ANALYSIS FOR THE COMBINATION OF ATMOSPHERIC DISTILLATION COLUMN AND FURNACES USED TO HEAT THE FEED (See Fig. A.3.2)

Stream Number	$\Delta H_T$ (kJ/kg) (Eq.2.8)	$\Delta H_p$ (kJ/kg) (Eq.2.12)	$\Delta H$ (kJ/kg) (Eq.2.6)	$\Delta S_T$ (kJ/kgK) (Eq.2.9)	$-\Delta S_p$ (kJ/kgK) (Eq.2.13)	$\Delta S$ (kJ/kgK) (Eq.2.7)	$A_v$ (kJ/hr) (Eq.1.7a)
22	447.3525	-0.1126	447.2399	1.1430	0.00107	1.14193	67531124
58	1484.56	0	1484.56	3.7140	0.3120	3.402	751810
115	3394.11	0	3394.11	7.8437	0	7.8437	2536050
TOTAL INPUT							70818984
31	14.8769	0	14.8769	0.08780	0.2805	0.1927	115899
33	57.7390	-0.0120	57.7270	0.1905	0.00073	0.18977	3689
34	32.48	-0.0095	32.4705	0.1063	0.0006	0.1057	54930
39	297.88	-0.0764	297.8086	0.8294	0.0011	0.8283	2769517
43	446.97	-0.1078	446.8622	1.1543	0.0011	1.1532	7384855
47	603.79	-0.1360	603.654	1.4515	0.0010	1.4505	11764725
50	682.45	-0.1509	682.2991	1.5918	0.0010	1.5908	2482021
53	682.36	-0.1495	682.2105	1.5501	0.0010	1.5581	80131729
TOTAL OUTPUT							104707395

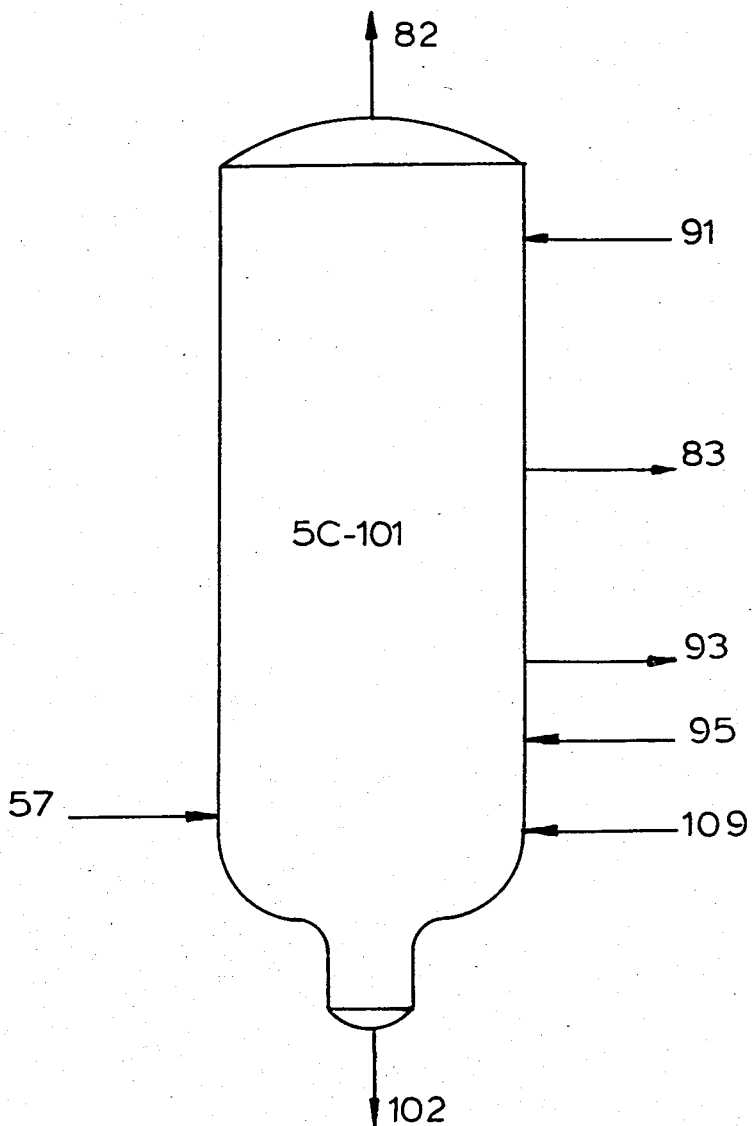

Figure A.3.3 Vacuum distillation tower

TABLE A.3.3 AVAILABILITY ANALYSIS FOR VACUUM DISTILLATION COLUMN (See Fig. A.3.3)

Stream Number	$\Delta H_T$ (kJ/kg) (Eq.2.8)	$\Delta H_P$ (kJ/kg) (Eq.2.12)	$\Delta H$ (kJ/kg) (Eq.2.6)	$\Delta S_T$ (kJ/kgK) (Eq.2.9)	$-\Delta S_P$ (kJ/kgK) (Eq.2.13)	$\Delta S$ (kJ/kgK) (Eq.2.7)	$A_V$ (kJ/hr) (Eq.1.7a)
57	867.933	-0.7317	867.2013	1.8606	0.0040	1.8566	90213788
91	104.105	-0.0591	104.0459	0.3220	0.0017	0.3203	1473492
95	654.421	-0.4831	653.9379	1.5223	0.0033	1.5190	26053153
109	465.775	-0.5415	465.2335	1.1447	0.0046	1.1401	<u>2684849</u>
TOTAL INPUT							120425282
82	175.8126	0	175.8126	0.1700	-0.0004	0.1696	1007185
83	407.9832	0.0240	408.0072	1.0643	-0.0004	1.0647	21435339
93	654.4214	0.0077	654.4291	1.5223	-0.00004	1.52234	38283545
102	749.2709	0.0419	749.3128	1.6391	-0.00008	1.63918	<u>45547906</u>
TOTAL OUTPUT							106273975

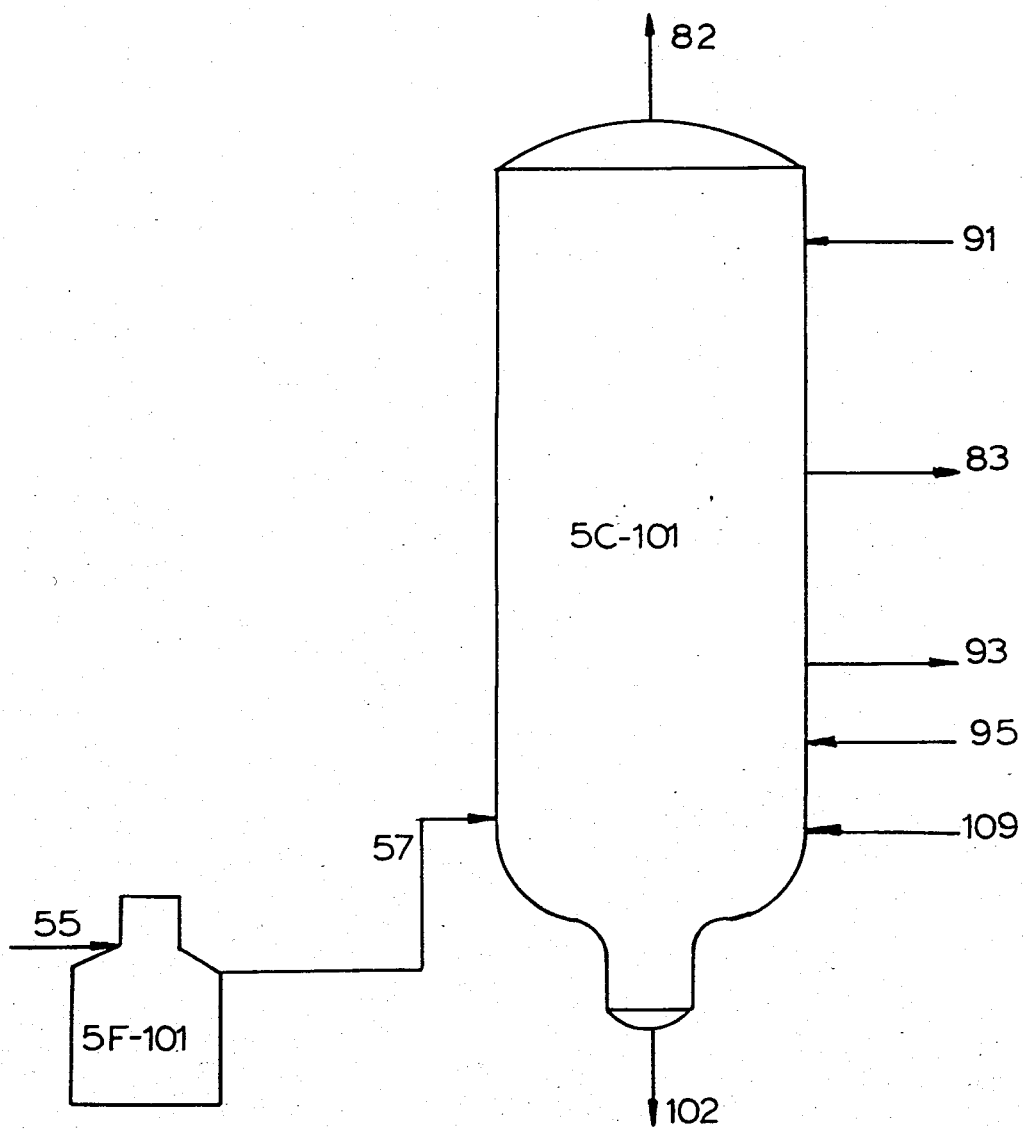

Figure A.3.4 Vacuum distillation tower and furnace used to heat the feed.

TABLE A.3.4. AVAILABILITY ANALYSIS FOR THE COMBINATION OF VACUUM DISTILLATION COLUMN AND FURNACE USED TO HEAT THE FEED (See Fig. A.3.4)

Stream Number	$\Delta H_T$ (kJ/kg) (Eq. 2.8)	$\Delta H_P$ (kJ/kg) (Eq. 2.12)	$\Delta H$ (kJ/kg) (Eq. 2.6)	$\Delta S_T$ (kJ/kgK) (Eq. 2.9)	$-\Delta S_P$ (kJ/kgK) (Eq. 2.13)	$\Delta S$ (kJ/kgK) (Eq. 2.7)	$A_v$ (kJ/hr) (Eq. 1.7a)
55	672.501	-0.7317	671.7884	1.5419	0.0040	1.5379	61350761
91	104.105	-0.0591	104.0459	0.3220	0.0017	0.3203	1473492
95	654.421	-0.4831	653.9379	1.5223	0.0033	1.5190	26053153
109	465.775	-0.5415	465.2335	1.1447	0.0046	1.1401	<u>2684849</u>
TOTAL INPUT							91562255
82	175.8126	0	175.8126	0.1700	-0.0004	0.1696	1007185
83	407.9832	0.0240	408.0072	1.0643	0.0004	1.0647	21435339
93	654.4214	0.0077	654.4291	1.5223	-0.00004	1.52234	38283545
102	749.2709	0.0419	749.3128	1.6391	-0.0008	1.63918	<u>45547906</u>
TOTAL OUTPUT							106273975

TABLE A.3.5 AVAILABILITY ANALYSIS FOR THE STRIPPER (5C-3)

Stream Number	$\Delta H_T$ (kJ/kg) (Eq. 2.8)	$\Delta H_P$ (kJ/kg) (Eq. 2.12)	$\Delta H$ (kJ/kg) (Eq. 2.6)	$\Delta S_T$ (kJ/kgK) (Eq. 2.9)	$-\Delta S_P$ (kJ/kgK) (Eq. 2.13)	$\Delta S$ (kJ/kgK) (Eq. 2.7)	$A_V$ (kJ/hr) (Eq. 1.7a)
39	297.88	-0.0764	297.8036	0.8294	0.0011	0.8283	2769517
43	446.97	-0.1078	446.8622	1.1543	0.0011	1.1532	7384885
47	603.79	-0.1360	603.654	1.4515	0.0010	1.4505	11764725
116	3394.11	0	3394.11	7.8437	-	7.8437	<u>779835</u>
TOTAL INPUT							22698962
58	1484.56	0	1484.56	3.7140	0.3120	3.402	751810
59	480.22	-0.1142	480.1058	1.2309	0.0011	1.2298	6173950
64	464.48	-0.1109	464.3691	1.1903	0.0011	1.1892	7775566
69	447.86	-0.1079	447.7521	1.1476	0.0010	1.1466	<u>7280004</u>
TOTAL OUTPUT							21981330

TABLE A.3.6 AVAILABILITY ANALYSIS FOR DEBUTANIZER COLUMN (5C-5)

Stream Number	$\Delta H_T$ (kJ/kg) (Eq.2.8)	$\Delta H_P$ (kJ/kg) (Eq.2.12)	$\Delta H$ (kJ/hr) (Eq.2.6)	$\Delta S_T$ (kJ/kgK) (Eq.2.9)	$-\Delta S_P$ (kJ/kgK) (Eq.2.13)	$\Delta S$ (kJ/kgK) (Eq.2.7)	$A_v$ (kJ/hr) (Eq.1.7a)
75	230.0796	-0.2115	229.8681	0.6704	0.0038	0.6666	<u>1764565</u>
TOTAL OUTPUT							1764565
76	36.1071	0	36.1071	0.2068	0.3645	-0.1577	427309
80	337.2693	-0.2519	337.0174	0.9328	0.0034	0.9294	<u>3085447</u>
TOTAL OUTPUT							3512756

TABLE A.3.7 AVAILABILITY ANALYSIS FOR DEBUTANIZER O/H DRUM (5C-6)

Stream Number	$\Delta H_T$ (kJ/kg) (Eq.2.8)	$\Delta H_p$ (kJ/kg) (Eq.2.10)	$\Delta H$ (kJ/kg) (Eq.2.6)	$\Delta S_T$ (kJ/kgK) (Eq.2.9)	$-\Delta S_p$ (kJ/kgK) (Eq.2.11)	$\Delta S$ (kJ/kgK) (Eq.2.7)	$A_v$ (kJ/hr) (Eq.1.7a)
77	21.0915	0	21.0915	0.1229	0.3645	-0.2416	478660
TOTAL INPUT							478660
78	21.4319	0	21.4319	0.12485	0.2843	-0.15945	309162
79	18.7391	0	18.7391	0.09695	0.38310	-0.28615	68336
TOTAL OUTPUT							377498

TABLE A.3.8 AVAILABILITY ANALYSIS FOR ATMOSPHERIC O/H DRUM (5C-4)

Stream Number	$\Delta H_T$ (kJ/kg) (Eq.2.8)	$\Delta H_P$ (kJ/kg) (Eq.2.10)	$\Delta H$ (kJ/kg) (Eq.2.6)	$\Delta S_T$ (kJ/kgK) (Eq.2.9)	$-\Delta S_P$ (kJ/kgK) (Eq.2.11)	$\Delta S$ (kJ/kgK) (Eq.2.7)	$A_V$ (kJ/hr) (Eq.1.7a)
	14.8769	0	14.8769	0.08780	0.4403	-0.3525	192235
30	57.7390	-0.0125	57.7265	0.1905	0.00076	0.18974	3715
	32.48	-0.0190	32.461	0.1063	0.0012	0.1051	191599
TOTAL INPUT							387549
31	14.8769	0	14.8769	0.08780	0.2805	-0.1927	115899
33	57.7390	-0.0063	57.7327	0.1905	0.00038	0.19012	3379
34	32.48	-0.0095	32.4705	0.1063	0.0006	0.1057	54930
35	32.48	-0.0095	32.4705	0.1063	0.0006	0.1057	108245
TOTAL OUTPUT							282453

TABLE A.3.9 AVAILABILITY ANALYSIS OF STREAMS RELATED TO THE FURNACES

Furnaces	5F-1		5F-3		5F-101	
	23	25	24	26	55	57
Stream No	(INPUT)	(OUTPUT)	(INPUT)	(OUTPUT)	(INPUT)	(OUTPUT)
$\Delta H_T$ (kJ/kg) (Eq. 2.8)	447.3525	745.7736	447.3525	761.6669	672.5662	867.9332
$\Delta H_p$ (kJ/kg) (Eq. 2.12)	-0.1126	-0.1668	-0.1126	-0.1694	-0.6040	-0.7320
$\Delta H$ (kJ/kg) (Eq. 2.6)	447.2399	745.6068	447.2399	761.4975	671.9622	867.2012
$\Delta S_T$ (kJ/kgK) (Eq. 2.9)	1.1430	1.6956	1.1430	1.7228	1.5424	1.8606
$-\Delta S_p$ (kJ/kgK) (Eq. 2.13)	0.0011	0.0011	0.0011	0.0011	0.0040	0.0040
$\Delta S$ (kJ/kgK) (Eq. 2.7)	1.1419	1.6945	1.1419	1.7217	1.5384	1.8566
$A_v$ (kJ/hr) (Eq. 1.7a)	40948614	92134373	26558155	61758680	61357887	90213759

TABLE A.3.10 AVAILABILITY ANALYSIS FOR HEAT EXCHANGERS BEFORE DESALTERS

Heat Exch.	5E-1				5E-2				5E-3			
	4 (INPUT)	5 (OUTPUT)	40 (INPUT)	41 (OUTPUT)	3 (INPUT)	7 (OUTPUT)	61 (INPUT)	62 (OUTPUT)	5 (INPUT)	6 (OUTPUT)	44 (INPUT)	45 (OUTPUT)
Stream Number												
$\Delta H_T$ (kJ/kg) (Eq. 2.8)	9.7597	74.0094	297.8791	123.6947	7.5826	62.4288	300.8633	91.1684	74.0094	143.7050	446.97	154.46
$\Delta H_p$ (kJ/kg) (Eq. 2.12)	-0.1079	-0.2510	-0.7406	-0.03831	-0.1028	-0.2259	-0.2588	-0.1072	-0.2510	-0.3966	-0.1078	-0.0463
$\Delta H$ (kJ/kg) (Eq. 2.6)	9.6518	73.7584	297.1385	133.6564	7.4798	62.2029	300.6075	91.0612	73.7584	143.3084	446.8622	154.4137
$\Delta S_T$ (kJ/kgK) (Eq. 2.9)	0.03244	0.2338	0.8294	0.3797	0.02525	0.1989	0.8365	0.2859	0.2338	0.4323	1.1543	0.4630
$-\Delta S_p$ (kJ/kgK) (Eq. 2.13)	0.0090	0.0090	0.0010	0.0010	0.0090	0.0090	0.0036	0.0036	0.0090	0.0090	0.0011	0.0011
$\Delta S$ (kJ/kgK) (Eq. 2.7)	0.0234	0.2248	0.8284	0.3787	0.0162	0.1899	0.8329	0.2823	0.2248	0.4233	1.1532	1.4619
$A_V$ (kJ/hr) (Eq. 1.7a)	1158336	2926761	8125695	1746153	527833	1117023	2847386	376863	2926760	7422850	11121036	1803537
$A_V$ (kJ/hr)	TOTAL INPUT		TOTAL OUTPUT		TOTAL INPUT		TOTAL OUTPUT		TOTAL INPUT		TOTAL OUTPUT	
	9284031		4672914		3375219		1493886		14047796		9226387	

TABLE A.3.10 CONT'D

Heat Exchangers	5E-4				5E-16			
	7 (INPUT)	8 (OUTPUT)	65 (INPUT)	66 (OUTPUT)	8 (INPUT)	9 (OUTPUT)	71 (INPUT)	72 (OUTPUT)
Stream Number	7	8	65	66	8	9	71	72
$\Delta H_T$ (kJ/kg) (Eq. 2.8)	62.4288	148.6709	423.348	131.0796	148.6709	177.6345	390.1338	302.8637
$\Delta H_p$ (kJ/kg) Eq. 2.12	-0.2259	-0.4066	-0.3133	-0.2284	-0.4066	-0.4643	0.5288	-0.4340
$\Delta H$ (kJ/kg) (Eq. 2.6)	62.2029	148.2643	423.0347	130.8512	148.2643	177.1702	389.605	302.4297
$\Delta S_T$ (kJ/kgK) (Eq. 2.9)	0.1989	0.4458	1.1047	0.4111	0.4458	0.5229	1.0265	0.8321
$-\Delta S_p$ (kJ/kgK) (Eq. 2.13)	0.0090	0.0090	0.003	0.003	0.0090	0.0090	0.0057	0.0057
$\Delta S$ (kJ/kgK) (Eq. 2.7)	0.1899	0.4368	1.1014	0.4081	0.4368	0.5139	1.0208	0.8264
$A_y$ (kJ/hr) (Eq. 1.7a)	1117023	3601790	6702049	653038	3601790	4781980	5862053	3854825
$A_y$ (kJ/hr)	TOTAL INPUT		TOTAL OUTPUT		TOTAL INPUT		TOTAL OUTPUT	
	7819072		4254828		9463843		8636805	

TABLE A.3.11 AVAILABILITY ANALYSIS FOR HEAT EXCHANGERS AFTER DESALTERS

Heat Exch.	5E-104A				5E-105B				5E-106A			
Stream Number	13	15	86	88	15	17	110	111	17	19	97	99
	(INPUT)	(OUTPUT)	(INPUT)	(OUTPUT)	(INPUT)	(OUTPUT)	(INPUT)	(OUTPUT)	(INPUT)	(OUTPUT)	(INPUT)	(OUTPUT)
$\dot{Q}_T$ (kJ/kg) (q.2.8)	226.9870	278.2094	407.9823	290.0378	278.2094	322.7941	465.7755	364.6352	322.7941	345.5837	654.4225	388.2672
$\dot{Q}_P$ (kJ/kg) (q.2.12)	-0.0644	-0.0777	-0.3587	-0.2749	-0.0777	-0.0872	-0.5582	-0.4619	-0.0872	-0.0920	-0.4987	-0.3333
$\dot{Q}_T$ (kJ/kg) (q.2.6)	226.9206	278.1317	407.6236	289.7629	278.1317	322.7069	465.2173	364.1733	322.7069	345.4917	653.9238	387.9339
$\dot{Q}_T$ (kJ/kgK) (q.2.9)	0.6485	0.7725	1.0643	0.8022	0.7725	0.8750	1.1447	0.9424	0.8757	0.9261	1.5223	1.0115
$\dot{S}_P$ (kJ/kgK) (q.2.13)	0.0011	0.0011	0.0038	0.0038	0.0011	0.0011	0.0046	0.0046	0.0011	0.0011	0.0033	0.0033
$\dot{Q}_T$ (kJ/kgK) (q.2.7)	0.6474	0.7714	1.0605	0.7984	0.7714	0.8739	1.1401	0.9378	0.8739	0.9250	1.5190	1.0082
$\dot{Q}_T$ (kJ/hr) (q.1.7a)	14311112	20313793	14426974	8165219	20313793	26220115	19224883	12979606	26220115	29401400	6162636	2678953

TABLE A.3.11 CONT'D

Heat Exch.	5E-104B				5E-105A				5E-106B			
Stream Name	12 (INPUT)	14 (OUTPUT)	85 (INPUT)	87 (OUTPUT)	14 (INPUT)	16 (OUTPUT)	56 (INPUT)	113 (OUTPUT)	16 (INPUT)	18 (OUTPUT)	96 (INPUT)	98 (OUTPUT)
$\Delta H_T$ (kJ/kg) (Eq. 2.8)	215.1293	245.6408	407.9823	299.8899	245.6408	328.4604	672.5678	409.1255	328.4604	371.6184	654.4228	388.267
$\Delta H_p$ (kJ/kg) (Eq. 2.12)	-0.0637	-0.0706	0.3587	0.2821	-0.0706	-0.0884	-0.6043	-0.4124	-0.0884	-0.0974	-0.4987	-0.3333
$\Delta H$ (kJ/kg) (Eq. 2.6)	215.0656	245.5702	407.6236	299.6078	245.5702	328.372	671.9635	408.7131	328.372	371.521	653.9241	387.933
$\Delta S_T$ (kJ/kgK) (Eq. 2.9)	0.6188	0.6942	1.0643	0.8251	0.6942	0.8880	1.5454	1.0492	0.8880	0.9835	1.5223	1.0115
$-\Delta S_p$ (kJ/kgK) (Eq. 2.13)	0.0011	0.0011	0.0038	0.0038	0.0011	0.0011	0.0040	0.0040	0.0011	0.0011	0.0033	0.0033
$\Delta S$ (kJ/kgK) (Eq. 2.7)	0.6177	0.6931	1.0605	0.8213	0.6931	0.8869	1.5414	1.0452	0.8869	0.9824	1.5190	1.0082
$A_Y$ (kJ/hr) (Eq. 1.7a)	6523172	8214511	7213441	4320476	8214511	13487059	17092178	7817016	13487059	16579098	6162645	2678953

TABLE A.3.11 CONT'D

Heat Exch.	5E-107A				5E-107B			
	19 (INPUT)	21 (OUTPUT)	105 (INPUT)	107 (OUTPUT)	18 (INPUT)	20 (OUTPUT)	104 (INPUT)	106 (OUTPUT)
Stream Number								
$\Delta H_T$ (kJ/kg) (Eq. 2.8)	345.5837	438.5404	749.2709	376.4313	371.6184	452.2393	749.2709	561.5850
$\Delta H_p$ (kJ/kg) (Eq. 2.12)	-0.0920	-0.1107	-0.8008	-0.4736	-0.0974	-0.0437	-0.8008	-0.6443
$\Delta H$ (kJ/kg) (Eq. 2.6)	345.4917	438.4297	748.4701	375.9577	371.5210	452.1956	748.4701	560.9407
$\Delta S_T$ (kJ/kgK) (Eq. 2.9)	0.9261	1.1246	1.6391	0.9671	0.9835	1.1526	1.6391	1.3222
$-\Delta S_p$ (kJ/kgK) (Eq. 2.13)	0.0011	0.0011	0.0046	0.0046	0.0011	0.0011	0.0046	0.0046
$\Delta S$ (kJ/kgK) (Eq. 2.7)	0.9250	1.1235	1.6345	1.9625	0.9824	1.1515	1.6345	1.3176
$A_V$ (kJ/hr) (Eq. 1.7a)	29401400	43623939	22822144	7782265	16579930	22953204	22822144	14694083

TABLE A.3.12 AVAILABILITY ANALYSIS FOR PUMPS IN PLANT 5

Pumps	IN			OUT			Pumps	IN			OUT		
	$\Delta H$ (kJ/kg) (Eq.2.6)	$\Delta S$ (kJ/kgK) (Eq.2.7)	$A_V$ (kJ/hr) (Eq.1.7a)	$\Delta H$ (kJ/kgK) (Eq.2.6)	$\Delta S$ (kJ/kgK) (Eq.2.7)	$A_V$ (kJ/hr) (Eq.1.7a)		$\Delta H$ (kJ/kg) (Eq.2.6)	$\Delta S$ (kJ/kgK) (Eq.2.7)	$A_V$ (kJ/hr) (Eq.1.7a)	$\Delta H$ (kJ/kg) (Eq.2.6)	$\Delta S$ (kJ/kgK) (Eq.2.7)	$A_V$ (kJ/hr) (Eq.1.7a)
5G-1	9.7548	0.0320	138163	9.6522	0.0234	1691676	5G-8	447.7424	1.1465	7281727	447.3064	1.1421	7341455
5G-2	32.4665	0.1058	104481	32.3875	0.1009	153281	5G-9	682.2114	1.5583	80110142	681.7527	1.5552	80281183
5G-3	297.8028	0.8283	8237838	297.6170	0.8257	8333075	5G-10	32.4665	0.1058	53020	31.9271	0.1010	103377
5G-4	446.8609	1.1532	11120896	446.7073	1.1517	11152511	5G-20	682.3029	1.5907	2482421	682.3599	1.5884	2491270
5G-5	603.6514	1.4505	14354951	603.5044	1.4494	14370093	5G-101	408.0972	1.0647	21435339	407.6534	1.0609	21619293
5G-6	480.1065	1.2298	6173988	479.8636	1.2275	6198031	5G-102	654.4290	1.5223	38285618	653.9399	1.5189	38385554
5G-7	464.3737	1.1892	7775892	464.0841	1.1864	7814406	5G-104	749.3128	1.6391	45552070	748.4975	1.6345	45649072

TABLE A. 3.13 AVAILABILITY ANALYSIS FOR OVERALL PLANT 5 (See Fig. 3.1 and 3.2)

Stream No	$\Delta H_T$ (kJ/kg) (Eq. 2.8)	$\Delta H_p$ (kJ/kg) (Eq. 2.12)	$\Delta H$ (kJ/kg) (Eq. 2.9)	$\Delta S_T$ (kJ/kgK) (Eq. 2.9)	$-\Delta S_p$ (kJ/kgK) (Eq. 2.7)	$\Delta S$ (kJ/kgK) (Eq. 2.7)	$A_v$ (kJ/hr) (Eq. 1.7a)
1	9.7601	-0.005280	9.75482	0.03244	0.0004	0.03204	130649
115	3394.11	0	3394.11	7.84372	0	7.84372	2536035
116	3394.11	0	3394.11	7.84372	0	7.84372	779831
TOTAL							3446515
81	28.5297	-0.0423	28.4874	0.09370	0.00272	0.09098	70660
63	43.3990	-0.0473	43.3517	0.14076	0.00243	0.13833	115701
68	41.9376	-0.0447	41.8929	0.13603	0.00230	0.13373	144314
74	35.8214	-0.0398	35.7816	0.11661	0.00217	0.11444	115209
52	35.6406	-0.0390	35.6016	0.11601	0.00213	0.11388	19849
92	104.1060	-0.07350	104.0325	0.32221	0.00210	0.32011	560355
101	83.4231	-0.0615	83.3616	0.26104	0.00199	0.25905	377532
114	129.2609	0.0825	129.1784	0.39016	0.00193	0.38823	1084074
112	131.8719	0.0831	131.7888	0.39447	0.00181	0.39266	2264086
82	232.1874	0.1400	232.0434	0.66602	0.00231	0.66371	275397
31	14.8769	0	14.8769	0.08780	0.2805	-0.1927	115899
79	18.7391	0	18.7391	0.09695	0.38310	-0.28615	68336
78	21.4319	0	21.4319	0.12485	0.2843	0.15945	309162
33	57.7390	0.0063	57.7327	0.1905	0.00038	0.19012	3379
TOTAL							5523953

APPENDIX 4

AVAILABILITY CALCULATIONS FOR  
PLANT 6

1. A SAMPLE CALCULATION OF HSRN STREAM (1) (See TABLE 3.2.1)

For the availability calculation of HSRN. temperature, pressure,  $K_w$ ,  $^{\circ}\text{API}$  and composition by volume % were supplied by IPRAŞ.  $\Delta A_{V_{O-1}}$  was calculated by using Eq. (1.7a) and data from TABLE A.2.1 (see TABLE 3.2.1). But the composition of HSRN must be known for the calculation of  $A_{V_O}$ . The composition of HSRN was calculated as follows:

<u>Component</u>	<u>Formula</u>	<u>Volume (m<sup>3</sup>/hr)</u>	<u>Density (gr/cm<sup>3</sup>)</u>	<u>Mass</u>	<u>MW</u>
Paraffins	C <sub>9</sub> H <sub>20</sub>	21.535	0.7133	15376	128
Naphtenes	C <sub>9</sub> H <sub>18</sub>	14.952	0.7945	11889	126
Aromatics	C <sub>9</sub> H <sub>12</sub>	3.392	0.8718	2956	120

Densities were taken from API Research Project 44 (1). Paraffins as n-nonane, naphtenes as n-butyl cyclo hexane aromatics as 1,3,5 trimethyl benzene were used to estimate  $A_{V_O}$  of HSRN. Standard chemical availabilities of each component were calculated from Eq. (1.10):

<u>Component</u>	<u><math>n_i</math> (<math>\frac{\text{kmole}}{\text{hr}}</math>)</u>	<u><math>x_i</math></u>	<u><math>A_{V_O}</math> (kJ/kmole)</u>	<u><math>x_i A_{V_O}</math> (kJ/kmole)</u>
C <sub>9</sub> H <sub>20</sub>	120.125	0.5023	5 946 093	2986723
C <sub>9</sub> H <sub>18</sub>	94.357	0.3946	5 740 534	2265215
C <sub>9</sub> H <sub>12</sub>	24.658	0.1031	5 076 483	523385

$$A_{V_O} = (\text{kJ/kmole}) = 5775323$$

$$MW_{av} = 126.39$$

$$A_{V_o} = \sum x_i A_{V_o} = 5775323 \frac{\text{kJ}}{\text{kmole}} \times \frac{1 \text{ kmole}}{126.39 \text{ kg}} = 45694 \frac{\text{kJ}}{\text{kg}}$$

Availability change due to mixing must be calculated since availability of HSRN calculated from properties of pure components. In this case, this change represents a correction term in availability calculations. It is calculated by using Eq. (2.20a) where  $\Delta A_{V_{corr}} = \Delta A_{V_{mix}}$

Component	$n_i$ ( $\frac{\text{kmole}}{\text{hr}}$ )	$x_i$	$n_i \ln x_i$ ( $\frac{\text{kmole}}{\text{hr}}$ )
$C_9H_{20}$	120.125	0.5023	-82.7130
$C_9H_{18}$	94.357	0.3946	-87.7409
$C_9H_{12}$	24.658	0.1031	-56.02443

$$\sum n_i \ln x_i = -226.4782$$

$$\Delta A_{V_{corr}} = 8.314 \frac{\text{kJ}}{\text{kmole.K}} \times 298\text{K} \times (-226.4782) \frac{\text{kmole}}{\text{hr}}$$

$$\Delta A_{V_{corr}} = -561116 \text{ kJ/hr}$$

Then the total availability change is calculated:

$$\Delta A_{V^t} = A_{V_o} + A_{V_{o-1}} + \Delta A_{V_{corr}}$$

$$A_{V_o} = 45694 \frac{\text{kJ}}{\text{kg}} \times 30224 \frac{\text{kg}}{\text{hr}} = 13810055456 \frac{\text{kJ}}{\text{hr}} \text{ (See TABLE 3.2.1)}$$

$$A_{V_{o-1}} = 147257 \frac{\text{kJ}}{\text{hr}} \text{ (See TABLE 3.2.1)}$$

$$A_{V^t} = 1381055456 + 147257 - 561116 = 1380641597 \text{ kJ/hr}$$

2. A SAMPLE CALCULATION FOR LPG STREAM (30)

Component	$x_i$	MW	$x_i MW$	$A_{V_o}$ (kJ/kmol)	$x_i A_{V_o}$ (kJ/kmol)
H <sub>2</sub> O	0.0001	18	0.0018	0	0
H <sub>2</sub> S	0.0004	34	0.0136	504540	202
H <sub>2</sub>	0.0029	2	0.0058	237191	687
C <sub>1</sub>	0.0182	16	0.2912	817971	14887
C <sub>2</sub>	0.1276	30	3.828	1467453	187247
C <sub>3</sub>	0.3481	44	15.3164	2108441	733948
i-C <sub>4</sub>	0.2476	58	14.3608	2745496	679785
n-C <sub>4</sub>	0.2427	58	14.0766	2747797	666890
i-C <sub>5</sub>	0.0081	72	0.5832	3380041	27378
n-C <sub>5</sub>	0.0043	72	0.3096	3385815	14559
TOTAL			48.787		2325583

$MW_{av} = 48.787$

Component	$x_i$	$n_i$ ( $\frac{\text{kmole}}{\text{hr}}$ )	$n_i \ln x_i$ (kmole/hr)
H <sub>2</sub> O	0.0001	0.012	-0.1105
H <sub>2</sub> S	0.0004	0.049	-0.3834
H <sub>2</sub>	0.0029	0.353	-2.0626
C <sub>1</sub>	0.0182	2.216	-8.8780
C <sub>2</sub>	0.1276	15.538	-31.9905
C <sub>3</sub>	0.3481	42.388	-44.7306
i-C <sub>4</sub>	0.2476	30.150	-42.0876
n-C <sub>4</sub>	0.2427	29.55	-41.8407
i-C <sub>5</sub>	0.0081	0.986	-4.7485
n-C <sub>5</sub>	0.0043	0.524	-2.8553
TOTAL			-179.6877

$$A_{V_O} = \sum_i x_i A_{V_O} = 2325583 \text{ kJ/kmol} \times \frac{1 \text{ kmol}}{48.787 \text{ kg}} = 47668 \frac{\text{kJ}}{\text{kg}}$$

The correction term resulting from total availability change due to mixing is given by:

$$\Delta A_{V_{\text{ccrr}}} = 8.314 \frac{\text{kJ}}{\text{kmol K}} \times 298\text{K} \times (-179.6877) \frac{\text{kmole}}{\text{hr}}$$

$$\Delta A_{V_{\text{corr}}} = -445189 \frac{\text{kJ}}{\text{hr}}$$

TABLE A.4.1. RESULTS OF ENTHALPY, ENTROPY AND STANDART CHEMICAL AVAILABILITY CALCULATIONS FOR STREAM 19

Component	$Y_i$	MW	$\Delta H_T$ (kJ/kmol) (Eq. 2.8)	$y_i \Delta H_T$ (kJ/kmol)	$\Delta S_T$ (kJ/kmol) (Eq. 2.9)	$y_i \Delta S_T$ (kJ/kmol)	$-\Delta S_p$ (kJ/kmolK) (Eq. 2.11)	$\Delta S$ (kJ/kmol) (Eq. 2.7)	$A_{V_O}$ (kJ/kmol) (TABLE A.2.4)	$Y_i A_{V_O}$ (kJ/kmol)
H <sub>2</sub> S	0.0440	34	248.401	10.9296	1.4687	0.0646	-0.2587	0.3233	504539	22200
H <sub>2</sub>	0.3376	2	208.245	70.3035	1.4389	0.4857	3.7362	-3.2505	237190	80075
C <sub>1</sub>	0.2436	16	256.311	62.4373	1.5151	0.3691	2.0348	-1.6657	817971	199257
C <sub>2</sub>	0.1425	30	388.689	55.3881	2.2976	0.3274	0.5547	-0.2273	1467452	20911
C <sub>3</sub>	0.1116	44	696.856	77.7691	3.2530	0.3630	0.2072	0.1558	2108440	235301
i-C <sub>4</sub>	0.0354	58	728.063	25.7734	4.3119	0.1526	-0.2721	0.4247	2745495	97191
n-C <sub>4</sub>	0.0316	58	728.063	23.0067	4.3119	0.1363	-0.2730	0.4093	2747797	86830
i-C <sub>5</sub>	0.0135	72	899.089	12.1377	5.3150	0.0718	-0.2123	0.2841	3380417	45636
n-C <sub>5</sub>	0.0071	72	899.089	6.3835	5.3150	0.0377	-0.1495	0.1872	3385814	24039
P(C <sub>8</sub> )	0.0110	114	1071.050	11.7815	6.3315	0.0696	-0.1918	0.2614	5298862	58287
+ N(C <sub>6</sub> )	0.0110	84	807.667	6.8843	4.7741	0.0525	-0.1918	0.2443	3821182	42033
A(T)	0.0111	92	608.762	6.7572	3.7136	0.0412	-0.1926	0.2338	3831744	42532
TOTAL				369.5519				-2.6196		1142492

P-Paraffins, N-Naphthenes, A-Aromatics, T-Toluene

TABLE A.4.2. RESULTS OF ENTHALPY, ENTROPY AND STANDART CHEMICAL AVAILABILITY CALCULATIONS FOR STREAM 25

Component	$y_i$	MW	$\Delta H_T$ (kJ/kmol) (Eq. 2.8)	$y_i \Delta H_T$ (kJ/kmol)	$\Delta S_T$ (kJ/kmolK) (Eq. 2.9)	$y_i \Delta S_T$ (kJ/kmolK)	$-\Delta S_p$ (kJ/kmolK) (Eq. 2.11)	$\Delta S$ (kJ/kmolK) (Eq. 2.7)	$A_{V_0}$ (kJ/kmol) (TABLE A.2.4)	$y_i A_{V_0}$ (kJ/kmol)
H <sub>2</sub> O	0.0001	18	714.147	0.0714	4.0594	0.0004	-0.0011	0.0015	8594	0.8594
H <sub>2</sub>	0.6412	2	608.728	390.316	3.4603	2.2187	17.5434	-15.3247	237191	152087
C <sub>1</sub>	0.1527	16	766.163	116.993	4.3525	0.6646	2.3550	-1.6904	817971	124904
C <sub>2</sub>	0.0900	30	1170.687	105.362	6.6494	0.5984	0.9923	-0.3939	1467453	132071
C <sub>3</sub>	0.0673	44	1659.619	111.692	9.4260	0.6344	0.5794	0.055	2108441	141898
i-C <sub>4</sub>	0.0209	58	2193.458	45.843	12.4585	0.2604	-0.0234	0.2838	2745496	57381
n-C <sub>4</sub>	0.0153	58	2193.458	33.560	12.4585	0.1906	-0.0569	0.2475	2747797	42041
i-C <sub>5</sub>	0.0046	72	2708.151	12.457	15.3821	0.0707	-0.0630	0.1337	3380417	15550
n-C <sub>5</sub>	0.0023	72	2708.151	6.229	15.3821	0.0354	-0.0448	0.0802	3386861	7790
C <sub>6</sub> +	P	0.0028	114	4257.787	11.922	24.1842	0.0677	-0.0498	5302879	14848
	A (T)	0.0028	93	2392.762	6.700	13.5889	0.0380	-0.0156	3831745	10729
TOTAL	1.0000			841.2168				-16.4362		699301

P-Paraffins, A Aromatics, T-Toluene

TABLE A.4.3. RESULTS OF ENTHALPY, ENTROPY AND STANDART CHEMICAL AVAILABILITY CALCULATIONS FOR STREAM 29

Component	$Y_i$	MW	$\Delta H_T$ (kJ/kmol) (Eq.2.8)	$Y_i \Delta H_T$ (kJ/kmol)	$\Delta S_T$ (kJ/kmolK) (Eq.2.9)	$Y_i \Delta S_T$ (kJ/kmolK)	$-\Delta S_P$ (kJ/kmolK) (Eq.2.11)	$\Delta S$ (kJ/kmolK) (Eq.2.7)	$A_{V_O}$ (kJ/kmol) (TABLE A.2.4)	$Y_i A_{V_O}$ (kJ/kmol)
H <sub>2</sub> O	0.0002	18	243.384	0.0486	1.0429	0.0002	-0.0092	0.0094	8594	1.718
H <sub>2</sub>	0.137	2	208.245	28.5295	1.4389	0.1971	1.0291	-0.8320	237190	32495
C <sub>1</sub>	0.1722	16	256.311	44.1367	1.5151	0.2609	1.6211	-1.3602	817971	140855
C <sub>2</sub>	0.2529	30	388.689	98.2994	2.2976	0.5811	3.1895	-2.6084	1467452	371119
C <sub>3</sub>	0.2716	44	696.856	189.2660	3.2531	0.8835	3.5864	-2.7029	2108440	572652
i-C <sub>4</sub>	0.0957	58	728.063	69.6756	4.3119	0.4126	0.4333	-0.0207	2745495	262744
n-C <sub>4</sub>	0.0687	58	728.063	50.0179	4.3119	0.2962	0.1214	0.1748	2747797	188774
i-C <sub>5</sub>	0.0012	72	899.089	1.0789	5.3151	0.0064	-0.0381	0.0445	3380417	4057
n-C <sub>5</sub>	0.0005	72	899.089	0.4495	5.3151	0.0027	-0.0197	0.0224	3385814	1693
	1.0000			481.5021				-7.2733		1574391

APPENDIX 5

SAMPLE CALCULATIONS FOR PLANT 5

1. Calculation of availability change due to SEPARATION

A. Distillation tower (5C-2)

<u>Stream no</u>	<u>Flow (kg/hr)</u>	<u>MW</u>	<u><math>n_i</math> (kmole/hr)</u>	<u><math>x_i</math></u>	<u><math>n_i \ln x_i</math> (<math>\frac{\text{kmole}}{\text{hr}}</math>)</u>
34	56518	78	724.6	0.2430	-1025.09
39	54336	114	476.6	0.1599	-873.71
43	71553	149	480.2	0.1611	-876.71
47	68637	216	317.8	0.1066	-711.45
50	11919	257	46.4	0.0156	-193.05
53	367751	393	935.8	0.3139	-1084.29

$$\sum n_i \ln x_i = -4764.30$$

By Eq. 2.20

$$\Delta A_{V_{sep}} = -(8.314) \frac{\text{kJ}}{\text{kmole K}} \times (298\text{K}) \times (-4764.30) \frac{\text{kmole}}{\text{hr}}$$

$$\Delta A_{V_{sep}} = 11803896 \text{ kJ/hr}$$

B. Overall Plant 5 (See Fig. 3.1)

Stream No	Flow (kg/hr)	MW	$n_i$ ( $\frac{\text{kmole}}{\text{hr}}$ )	$x_i$	$n_i \ln x_i$ (kmole/hr)
81	51376	78	658.7	0.2305	-966.65
63	54336	114	476.6	0.1668	-853.57
68	70695	149	474.5	0.1661	-851.81
74	86637	216	317.8	0.1112	-698.02
52	11919	257	46.4	0.0162	-191.30
92	64858	250	259.4	0.0908	-622.32
101	612.42	340	180.1	0.0630	-497.91
114	80386	570	140.9	0.0493	-424.09
112	153226	630	243.2	0.0851	-599.23
82	8040	135	59.5	0.0210	-229.86
TOTAL			2857.1	1.0000	-5934.76

By Eq. (2.20):

$$\Delta A_{V_{\text{mix}}} = 8.314 \frac{\text{kJ}}{\text{kmoleK}} \times 298\text{K} \times (-5934.76) \frac{\text{kmole}}{\text{hr}}$$

$$\Delta A_{V_{\text{mix}}} = -14703795 \text{ kJ/hr}$$

$$\Delta A_{V_{\text{sep}}} = 14703795 \text{ kJ/hr}$$

2. Calculation of  $\Delta A_{v, \text{gen}}$  for the combination of atmospheric distillation column and furnaces used to heat the feed (See Fig. A.3.2)

Heat transfer occurs between crude oil, HSRN and kerosine in heat exchangers, 5E-1 and 5E-3, Availability change of crude in exchanger 5E-1 (See TABLE A.3.10 streams 4 and 5) is 1768425 kJ/hr. Availability change of crude in exchanger 5E-3 (See TABLE A.3.10 streams 5 and 6) is 4496090 kJ/hr. Total availability change of crude is 6264515 kJ/hr. Therefore;

$$\Delta A_{v, \text{crude}} = \Delta A_{v, \text{gen}} = 6264515 \text{ kJ/hr} \approx 62.64 \times 10^5 \text{ kJ/hr}$$

3. Calculation of availability efficiency of the combination of atmospheric distillation column and furnaces (5C-2+5F-1+5F-3; see TABLE 3.1.2).

$$\Delta A_{v, \text{sep}} = 118.0 \times 10^5 \text{ kJ/hr (see pp. 103)}$$

$$\Delta A_{v, \text{supp}} = 2135 \times 10^5 \text{ kJ/hr (see TABLES A.1.5 and A.1.6)}$$

$$\Sigma A_{v, \text{inlet}} = 708.2 \times 10^5 \text{ kJ/hr (see TABLE A.3.2)}$$

$$\Sigma A_{v, \text{outlet}} = 1047 \times 10^5 \text{ kJ/hr (see TABLE A.3.2)}$$

Then, using Eq. 2.23, availability efficiency is calculated as ( $\Sigma \Delta A_v$  in numerator =  $\Sigma A_{v, \text{outlet}} - \Sigma A_{v, \text{inlet}} + \Delta A_{v, \text{sep}}$ ):

$$\eta = \frac{(62.64 + 1047 - 708.2 + 118.0)}{2135}$$

2135

$$\eta = 24.33\%$$

APPENDIX 6

A HEAT AVAILABILITY DIAGRAM  
IN CONNECTION WITH PLANT 5

One of the most important considerations in building a modern crude unit is the design of the crude preheat exchanger train. There are almost infinite possibilities for arranging preheat exchanger train for crude units. Relatively few of these can be compared using hand calculations but with a computer any number of schemes can be evaluated (15). As a first step heat availability diagram is developed to determine the best configuration of heat exchanger train (25)

A heat availability diagram was constructed for a preheat exchanger train in Plant 5. Four streams, 40, 44, 48, 53, exchange heat with crude oil as seen in Fig. 3.1. Therefore, only these streams and crude oil were considered. Specific heats of these streams were assumed to be constant. Thus Fig. A.6.1 was constructed where temperature is plotted against heat content. Detailed construction is given in literature (13). The upper line is a composite heat curve of streams. It is constructed by adding together the heat contents of the streams over the same temperature ranges. The lower line is the heat curve for the crude oil. As more heat is transferred to the crude, the composite heat curve shifts to the right. When two curves touch, maximum heat is transferred to the crude oil and no more heat can be recovered without improvements in preheat exchanger design. The area between two composite heat curves corresponds to the loss of available energy due to

irreversibilities. The minimization of available energy loss can be achieved by minimizing the area between the composite heat curves.

In Fig. A.6.1, the area between upper and lower lines is quite large. It means that a great amount of available energy is dissipated. Therefore, the operating conditions must be changed to decrease available energy loss in the heat exchanger train. However, due to complexity of the problem a detailed calculations could not be made.

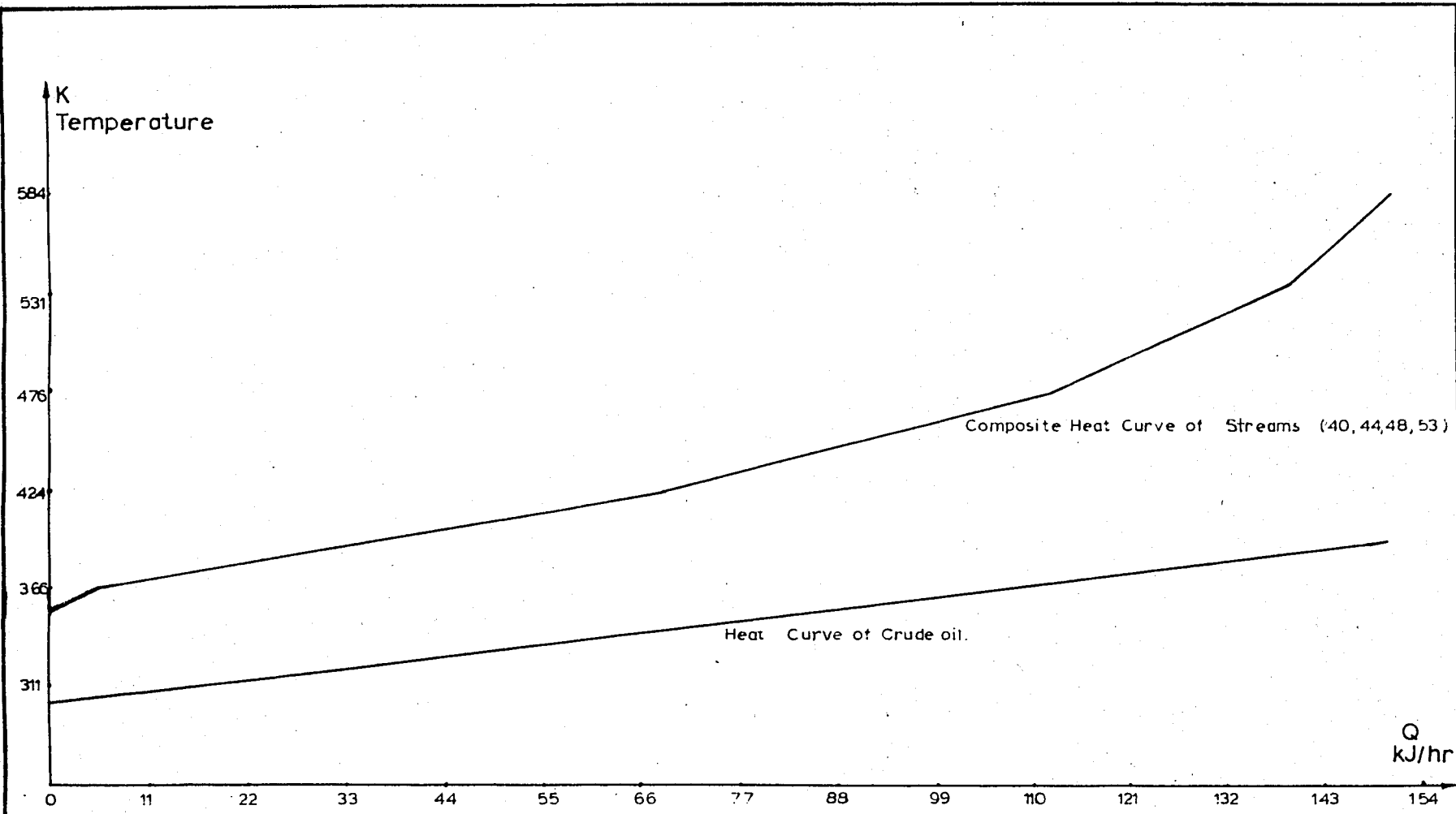

Fig A6.1 Heat Availability diagram