

A STUDY ON
THE OPTIMIZATION
OF
SWITCHING NETWORKS

FOR REFERENCE
NOT TO BE TAKEN FROM THIS ROOM

By

Çiğdem Mısırlı

B.S. in I.E. Boğaziçi University,

1980

Submitted to the Faculty of Engineering
in Partial Fulfillment of
the Requirements for the Degree of
MASTER OF SCIENCE
in
INDUSTRIAL ENGINEERING

Bogazici University Library



39001100315657

14

BOĞAZIÇI UNIVERSITY

1982

ACKNOWLEDGMENT

I would like to express my sincere gratitude to my thesis supervisor Mr. Çetin Evranuz for his continuous encouragement, help, support, and understanding during all the stages of this study.

I would also like to express my sincere gratitude to Dr. Gündüz Ulusoy for his numerous creative contributions and valuable discussions.

Thanks are also due to Doç.Dr. Bülent Sankur for all his contributions.

The two celebrated institutes, Industrial Engineering Department of Boğaziçi University and the Operational Research Division of Marmara Scientific and Industrial Research Institute and their respective staff deserve special thanks.

I would further like to thank Mr. Michael Sheridan of the Irish PTT, Mr. Ronald Mantel of Dr. Neher Laboratories-Netherlands, Mr. Jean-Michel Mepius of CNET-France, Mr. Alberto Tonietti of CSELT-Italy, Prof.Dr. İlker Baybars of Carnegie-Mellon University, Doç.Dr. Toğan Zeren and Mr. Yücel Çalıklı of the Turkish PTT for their lively discussions and comments.

I am indebted to my colleague Mr. Cengiz Pak of Sİ-TA for his vital contributions at the programming stages of this study without which my efforts at automation would have been blurred.

I also sincerely wish to thank Mr. Sermet Kuran of Hak Holding for offering many suggestions, proofreading, drawings, and for his boundless understanding and tolerance.

Nermin Ülgen and for initial stages Nihal Yener deserve special thanks for undertaking the demanding typing job which they both performed superbly.

ABSTRACT

The aim in switching network optimization problem is to obtain optimal link capacities so that the resulting network cost is minimized and a certain satisfactory level of service is supplied to the subscribers. Since the problem has a large size and encompasses nonlinearities, approximate solutions suffice.

In the present study, the optimization problem, its characteristics, and related teletraffic concepts are presented. A solution procedure is developed by considering the existing approaches and is applied to some small scale example networks to show its functioning and to set a comparison basis for future study.

ÖZET

Aboneler arasındaki telefon bağlantılarını sağlayan telekomünikasyon (uziletişim) şebekesi, iletişim ve santral şebekesi olarak ikiye ayrıştırılıp incelenmektedir. Santral şebekesi, birbirlerine devreler ile bağlanmış santrallardan oluşmaktadır. İletişim şebekesi ise santralları bağlayan iletişim sistemlerini içerir. Telekomünikasyon şebekesinin eniyilenmesi (optimizasyonu) iki etapta düşünülmektedir. Santral şebekesinin eniyilenmesi olan birinci kademeden çıktıkları ikinci optimizasyon kademesi olan iletişim şebekesinin eniyilenmesi problemine girdi olarak kullanılmaktadır. Bu çalışma santral şebekelerinin eniyilenmesi ile ilgili olup iletişim şebekelerinin eniyilenmesi çalışmanın kapsamının dışında kalmaktadır.

Santral şebekelerinin eniyilenmesindeki hedef eniyi (optimal) hat kapasitelerini tayin edip santrallar arası bağlantılara kaç devre konulacağını bulmaktır. Böyle bir hesaplama yapılırken şebeke maliyetini en azlamak ve abonelere yeterli bir servis seviyesi sağlamak amaçlanmaktadır. Problemin boyutunun büyük olması ve doğrusal olmayan ilişkileri içermesi nedeniyle ancak yaklaşık çözümler elde edilmektedir.

Bu çalışmada eniyilenecek olan santral şebekesi problemi, özellikleri ve konuya aydınlık getirebilecek gerekli bazı uztrafik kavramları tanımlanmıştır. Ayrıca, mevcut çözüm yaklaşımlarını da gözönünde bulundurarak bir çözüm yordamı geliştirilmiştir. Geliştirilen metodun işleyişini göstermek için çözüm yordamı, küçük boyutlu bazı örnek şebekelere uygulanmıştır. Böylece, ilerki çalışmalar için de karşılaştırma kriterleri meydana getirilmiştir.

TABLE OF CONTENTS

	<u>Page</u>
NOMENCLATURE	vii.
CHAPTER I. INTRODUCTION	1
CHAPTER II. CERTAIN RELATED ASPECTS OF TELETRAFFIC THEORY	4
II.1. Fundamental Definitions	4
II.2. Nature of Telephone Traffic	6
II.3. Grade of Service	7
CHAPTER III. APPROACHES TO SWITCHING NETWORK OPTIMIZATION PROBLEM	9
III.1. The Probabilistic Approach to Switching Network Optimization Problem	9
III.2. The Deterministic Approach to Switching Network Optimization Problem	13
III.3. The Overview of the Switching Network Optimization Problem	14
III.4. Approaches to the Calculation of Blocking Probability	14
CHAPTER IV. DEFINITION OF THE PROBLEM	17
IV.1. Characteristics of the Problem	17
IV.2. Examples on Network Structure	19
CHAPTER V. FORMULATION OF THE PROBLEM	21
V.1. Fundamental Theories Utilized in the Solution Procedure	21
V.1.1. The Erlang-B Formula	21
V.1.2. The Equivalent Random Theory (ERT)	24
V.2. Assumptions of the Model	26
V.3. Methodology	27

V.3.1. Initialization	28
V.3.2. Dimensioning of High Usage Links	29
V.3.2.1. The Optimization Problem	29
V.3.2.2. Economic Criteria	32
V.3.2.3. The Relationship Between the Marginal Efficiency Parameter and the High Usage Link Size	33
V.3.3. Dimensioning of Links Which are Offered Overflow Traffic	35
V.3.4. Dimensioning of Links Which are Offered Carried Traffic	38
V.3.5. Updating the Marginal Parameters	39
V.3.5.1. Updating the Marginal Capacity Parameter	39
V.3.5.2. Updating the Marginal Overflow Parameter	40
V.3.5.3. Termination of the Update Phase	42
V.3.6. Calculation of Grade of Service	42
V.3.7. Calculation of Gradients	45
V.3.8. Updating the Final Link Blocking Probabilities	47
V.3.9. Termination of the Overall Dimensioning Iterations	50
V.3.10. Implementation of the Algorithm	51
CHAPTER VI. NUMERICAL RESULTS AND DISCUSSION	57
VI.1. Example Problem	57
VI.2. Results of the Example Problem for Different Cases	69
VI.3. Results of the Test Network	74
CHAPTER VII. EXTENSIONS FOR FUTURE STUDY	79
CHAPTER VIII. CONCLUSION	83
BIBLIOGRAPHY	84

APPENDICES 88

A. DERIVATION OF THE OPTIMIZATION EQUATION FOR
EXAMPLARY CASES 89

 A.1. Triangular Routing 89

 A.2. Two Overflow Possibilities 91

B. DERIVATION OF THE POLYGONAL FUNCTION 96

C. EXAMPLES ON END-TO-END BLOCKING PROBABILITY CALCULATION 97

D. EXPLANATION OF THE COMPUTER PROGRAM 99

E. EXAMPLE NETWORKS 106

F. TEST NETWORKS 107

G. SOME PERTINENT RESULTS OF THE TEST NETWORK 112

H. LISTING OF THE COMPUTER PROGRAM 116

NOMENCLATURE

a	Overflow traffic
A	Offered traffic
A_C	Carried traffic
A^*	Equivalent random traffic
b_k	Blocking probability of link k
β	Marginal capacity parameter
C	Total network cost
C_k	Cost of supplying one circuit on link k
C_ℓ	Cost of supplying one circuit on link ℓ
CT_i	Cost of one erlang flowing through the tandem exchange i
$E_j(.)$	End-to-end blocking probability for traffic relation j
E_{\max}	The specified grade of service level
F_h	The set of high usage links
F_i	The set of tandem switches
F_k	The set of final links
F_ℓ	The set of final links for the traffic relation utilizing direct link ℓ
γ	Marginal overflow parameter
H	Marginal occupancy (efficiency) parameter
i	Subscript for tandem switches
j	Subscript for traffic relations
k	Subscript for final links
ℓ	Subscript for high usage links
L	Number of high usage links
L_C	Traffic load carried by the last trunk of a link
m	The index showing the number of links in the final route
M	Mean of the offered traffic
M_C	Mean of the carried traffic
M_o	Mean of the overflow traffic
N	Number of integer valued trunks (circuits) on a link
N^*	Number of equivalent group of circuits

r The index specifying the number of links in the alternate route
 t The index designating the links of the network
 T_i Amount of traffic flowing through the tandem switch i
 V Variance of the offered traffic
 V_C Variance of the carried traffic
 V_O Variance of the overflow traffic
 vmr The variance-to-mean ratio (coefficient of over-dispersion)
 X Number of real-valued trunks on a link
 XT_k The additional traffic to be handled on the final link k
 Y_i The additional traffic to be switched by the tandem exchange i

CHAPTER I

INTRODUCTION

A telecommunications network is the means of interconnecting telephone customers. A national network includes exchange (local) networks where each exchange area network is primarily concerned with local calls. A local central office interconnects local subscribers and has connections to other local central offices so that a call which originates in one central office can be passed to another central office for completion. The central office can also have connections to toll offices which are the gateway to the long-distance network. In short, telephone service, being either local or long-distance, is of two types.

The telecommunications network optimization is mainly an international problem. The problems arising in the investment planning of the telecommunications network for Turkey resemble in technical aspects the problems faced by other countries when planning their own investments. The investments made on the Turkish telecommunications network have been unsatisfactory in terms of service supplied since the subscribers are liable to receive the all-trunks-busy signal too frequently. Due to the stress of monetary constraints in Turkey, investment planning has become an even more crucial problem.

The optimization of telecommunication networks is vital for telephone traffic network designers in terms of investment value and system functioning. The network represents a large proportion of the capital assets of a telecommunications administration and its operating cost. The success of a telephone system depends on the way it handles subscribers' telephone calls. A telephone subscriber must be able to make a call whenever he desires at a cost which is not prohibitive. The telephone administration must provide this level of service through investments in plant equipment, depending on the number of subscribers and the volume of traffic. The major expenses of the telephone administration are the invested capital and the interest on it. Thus, profitability depends to a large extent on the system's not being over-engineered. On the other hand,

under-engineering the system is unacceptable from the point of view of customer service. That is, too few switches and interconnections would hinder the growth in the number of subscribers and cause productive time losses in waiting while too many switches and interconnections would increase the costs of the administration. To resolve the trade-off between cost and service, the investment in plant equipment must be minimized subject to a constraint set concerning the service levels.

The basic purpose of teletraffic theory is to find the conditions under which adequate service is given to the subscribers while the facilities providing the service are economically used. The necessary circuits to enable exchanges in a moderately large city may represent a capital investment of several millions of dollars. Therefore, even a small percentage of investment reduction, achieved by employing a dimensioning procedure, amounts to significant savings in total investment cost. This result can verify the fact that in switching network optimization problems, an approximate solution suffices. Currently utilized methods do not aim to attain the exact solution due to the structure of the problem which generally has a large size and many interdependancies between the variables.

A telecommunications network can be separated into a switching and a transmission network. The switching (switched) network comprises the switching nodes interconnected by groups of circuits while the transmission network consists of transmission systems interconnecting the switching nodes. The traditional transmission facility in a telecommunications network is cable. Recently, the use of radios and satallites have been initiated. The optimization of telecommunication networks is approached in two stages [6]. In the first stage, the switching network is optimized by applying a dimensioning procedure. The basic output of the switching network optimization problem is the link capacities, which are used as inputs to the transmission network optimization problem. In the transmission network optimization problem, given the linkwise circuit requirements, the minimum cost facility installation scheme is sought by determining the type of transmission system to be installed on the links. Transmission network optimization is totally out of the scope of this study. Only switching network optimization is analyzed in the thesis.

With the aim of defining switching network optimization problem clearly, in

Chapter II the necessary aspects of teletraffic theory are introduced. A brief review of the relevant literature on switching network optimization is given in Chapter III. Then, structurally the problem is defined in Chapter IV along with the general input requirements and the resulting outputs. Chapter V includes the fundamental theories used in the solution procedure, the specific assumptions of the developed model, and the solution algorithm for the switching network optimization problem. Numerical results of the developed algorithm are discussed in Chapter VI while the listing and explanation of the computer program are included in Appendices D and H.

CHAPTER II

CERTAIN RELATED ASPECTS OF TELETRAFFIC THEORY

II.I. FUNDAMENTAL DEFINITIONS

Telephone traffic is defined as the aggregate of telephone calls over a group of circuits with regard to the duration and the number of calls. The product of the number of calls during a period of time by the average holding time yields traffic flow. In traffic theory, the unit of time is one hour. Traffic flow, expressed in hour-calls, is termed as traffic intensity. The quantity of traffic used in dimensioning methods is the traffic intensity which represents the average number of simultaneous calls. Although traffic intensity is a dimensionless quantity, it is called the "erlang" after the Danish mathematician, Erlang, who is the founder of the telephone traffic theory. One erlang represents a circuit occupied for one hour. In the United States the term "unit call" (UC) or its synonymous term "hundred-call-second" (CCS) which expresses the sum of the number of busy circuits provided that the busy trunks were observed once every 100 seconds, is generally used. The relationship between the erlang and the UC or CCS can easily be established as:

$$1 \text{ erlang} = 36 \text{ UC} = 36 \text{ CCS} .$$

Telephone traffic is carried between exchanges or switching centers by circuits which are also termed as junctions or trunks in the literature. An exchange destined for subscribers in the same exchange area does not use the junction network. Tandem switches, employed in a telecommunication network, function solely as switching points for trunks between local central offices. Therefore, no traffic originates or terminates at a tandem switch.

To obtain feasible connections between switching centers, a procedure known as alternate routing is utilized in the telecommunication networks. Under alternate routing, traffic offered to a direct (first choice) route between

two exchanges and meeting congestion (blocking) is offered to a second choice (overflow) route. Networks which allow alternate routing of traffic are termed switching or switched because switching operations are required to alternately route a call. A link, whose traffic can be switched to an alternate route(s), is called a high usage link. All of the links in the network excluding the high usage links are termed as final links. The set of all final links constitutes the backbone of the network.

The network routing hierarchy permits the traffic which is blocked on a high usage link to be switched through other junctions. If a connection fails on a final link, then the call is "lost", and the caller must try to place the call again. The switching process, induced by alternate routing, tends to smooth out the peaks of traffic loads which occur throughout the network at different times of the day [16]. Making use of alternate routing, rather than allowing only direct junctions between each exchange pair, can decrease the total cost since less equipment will be required to service the overall traffic load on the network. Savings in total investment for tandem networks with a constant grade of service are about 10 % in the case of large networks [2]. The main advantage of alternate routing networks is the greater traffic carrying capacity of large groups of junctions by combining many small parcels of traffic on the second and/or higher order choice routes. Administratively, an alternate route trunk layout may be easier to monitor day by day than a large number of separate and independent intertoll groups since a close check only on the service given on the final routes can be sufficient to insure that all customers are being served satisfactorily [34].

For given congestion standards and specific levels of offered traffic there, are optimal values for the proportions of traffic routed via direct and alternate routes. The principal factors tending to increase the proportion of traffic on direct junctions are the generally lower junction and switching costs. On the other hand, increasing the traffic on the tandem network enables the direct junctions to operate at a greater traffic efficiency, and the aggregation of a number of small traffic parcels results in efficient use of the alternate routes. Basically, all the existing dimensioning procedures seek to attain the optimal routing of traffic, considering link and/or route blocking probabilities.

II.2. NATURE OF TELEPHONE TRAFFIC

An understanding of the distribution of telephone traffic with respect to time and destination is essential in determining the amount of telephone facilities required to serve the subscribers' needs. Telephone traffic varies according to location, season, month, week, day, and hour. These variations may be considered to be primarily systematic since their occurrence can be predicted within reasonable limits. However, the variation that occurs within an hour is not systematic. The random nature of the traffic distribution within an hour is based on the assumption that subscribers originate calls independently. Other important traffic fluctuation sources are the differing telephone usage rate of subscribers and the length of conversation. With the input traffic fluctuating, telephone network designers utilize the traffic intensity value obtained by considering the busy hour in the busy season or multihour engineering technique (see Chapter III) to supply satisfactory service. Sound demand forecasting, where customer demands are specified probabilistically between pairs of junctions by the utilization of the first two moments, is essential for a reliable network design.

The traffic distributions, which influence the dimensioning procedure of the network, can be divided into three main categories with respect to the variance-to-mean ratio, vmr [20]. When vmr is equal to unity, the traffic is defined as being random and is characterized by Poisson distribution. In the nonrandom case, the traffic is called smooth if its vmr is less than unity, and it is named rough or peaked if its vmr is greater than unity. Although random traffic is rarely found in practice, it is extensively used for its simplicity. In the case of smooth traffic, the utilization of Poisson distribution overestimates the number of trunks while for rough traffic, it results in an underestimation. Consequently, "Equivalent Random Theory" due to Wilkinson [34] or Fredericks' formula [30] is employed to deal with rough traffic that is encountered commonly in networks with alternate routing. The error in using Poisson distribution for smooth traffic is rather small and may be regarded as a safety factor.

To clarify the nature of telephone traffic in a network, the offered and the carried traffic must be differentiated. The carried traffic, which is obtained from traffic measurements, is the volume of traffic actually handled by the system. The offered traffic is greater than the carried traffic by the amount

of lost or blocked traffic, if any. Thus, the relationship between offered and carried traffic is expressed by,

$$\text{Offered Traffic} = \text{Carried Traffic} + \text{Lost Traffic}$$

The lost traffic can be thought of as that portion of the traffic which would overflow to an auxiliary route if the channels of the route under study are occupied. The characteristics of the traffic offered to the routes in a network are of fundamental importance in the calculation procedure. The freshly offered traffic to the first choice links is considered as being random. A Poisson distribution of offered traffic is produced by a random arrival of calls. The implied assumption is that the probability of a new call arrival in the next instant of time is independent of the number currently present in the system. When this randomness and the corresponding independence are disturbed, then the resulting distribution will no longer be Poisson. In overflow traffic, there will be more occurrences of large numbers of calls and also longer intervals when few or no calls are present [34]. The vmr of the overflow traffic is greater than unity, signifying peakedness whereas the vmr of the carried traffic is less than unity, signifying smoothness. Peaked traffic requires more paths while smooth traffic requires less paths than random traffic does to operate at a specified grade of service.

II.3. GRADE OF SERVICE

The concept of blocking refers to the fact that a call encounters an all-equipment-busy condition on a given link (link blocking) or in a given switch (switch blocking). Link blocking probability, expressed by the Erlang-B formula developed by Erlang, is the probability that all of the trunks of the considered link are busy. Link blocking probability is a direct function of the amount of traffic offered to that link and the number of trunks constructed for that link. The offered and carried traffics of a trunk group are different mainly due to the existence of link blocking. Each switch blocking is characterized by two different blocking probabilities, namely the incoming and the outgoing blocking probabilities [11].

In a circuit-switched telecommunication network optimization, generally the interest is on the overall blocking probability which is also called point-to-point congestion or end-to-end blocking. The point-to-point congestion value,

derived from the individual blocking probabilities of each link with or without regard to switch blocking, refers to the probability that a call at any originating node of the network does not reach its destination due to network problems. A highly related concept to overall blocking is the grade of service which is defined as the measure of service given in an exchange from the point of view of insufficiency of the telecommunication network system. Grade of service is the proportion of the unsuccessful calls relative to the total number of calls. The conventionally accepted value for grade of service is 0.01 [19].

As telephone networks grow and evolve over time, new switches and transmission facilities are introduced with the required capabilities. For ease of calculation, most of the current network dimensioning procedures aim to ensure the specified blocking levels to be met on final trunk groups during normal network conditions, at which abnormally high demand values and failures are not taken into consideration, rather than the point-to-point congestion criterion. The basic objective is that each subscriber should be able to communicate with the other subscribers with a high probability, except perhaps during certain abnormal periods.

CHAPTER III

APPROACHES TO SWITCHING NETWORK OPTIMIZATION PROBLEM

The hierarchical switching network optimization problem has been a substantial research area. New points of view and encouraging improvements have been accomplished. Yet, due to the lack of a universally acclaimed testing network to test and compare each proposed method, none of the solution methods emerges as being distinctly superior to the others. Besides, some of the methods have been restricted in the sense that they were planned for only special network designs. The strong trade-off between accuracy and ease of application is a drawback in the subject where even the level of accuracy is still open to research. Considering the vast sums of money expended to meet the current and future communication needs with a high degree of efficiency, and the continuing developments in the design of switches and transmission facilities, the sustenance of the research on telecommunication network optimization is obviously vital. The approaches and the discoveries of the existing researches can be influential guides for future study.

Over the past 30 years, there have been at least two basic approaches to the hierarchical switching network optimization problem [16].

III.1. THE PROBABILISTIC APPROACH TO SWITCHING NETWORK OPTIMIZATION PROBLEM

The first approach to the design problem incorporates specific probability distributions for each parcel of traffic, where a parcel is merely that portion of traffic which follows specific routes in the network. Different parcels can experience different blocking probabilities on the same trunk group. That is, a given trunk group may accommodate customer originated random traffic and also overflow traffic which is peaked.

The pioneering work representing the probabilistic approach, which has had widespread use throughout the telecommunications industry, was set in 1954 by Truitt [32]. The generally accepted name of the method reflects the fact that economic considerations are also part of the analysis. The method is termed the economic-hundred-call-second (ECCS). It is based on the concept of economic load on the last trunk. This method was introduced by Truitt for the simplest routing hierarchy which consists of a triad of junctions with only one overflow possibility and one specific time of day (single-hour). The design variables are the specific sizes of all trunk groups of the network.

Further important extensions of the ECCS-method occurred in three directions. First, accurate refinements concerning the overflow distributions were made following the equivalent random theory of Wilkinson [34]. Then, more complicated network hierarchies were introduced by Rapp [27] and other following researchers.

Currently, incorporating these two extensions to their work, three researchers have produced different solution techniques. There are three main options as to how the problem may be formulated. It can be (a) circuit based, (b) traffic based, or (c) blocking/circuit based [6]. Basically, these three solution procedures are iterative. Berry [1], [2], rather than decomposing the network into a high usage and a backbone part, considers the network as a whole. Initial values of traffic flows on all possible routes for all traffic relations are selected such that all point-to-point grade of service constraints are met. Accordingly, the offered traffic to all trunk groups and the trunk sizes are calculated. Then the new values of the traffic flows on all of the routes are provided by the use of a search method. The search method, employed by Berry, is the gradient projection method due to Rosen [28]. Berry's method is traffic based.

In contrast to Berry, Blaauw [4] applies decomposition to the network. Blaauw's method is blocking/circuit based. In this case, first the optimization problem is considered with fixed high usage group sizes, implying that the high usage trunks are separately optimized in advance by some method. The optimization of the high usage trunks can be achieved by Pratt's [26] procedure, which will be discussed in detail in the following chapters of the thesis. Then, the optimization problem is considered as a dimensioning problem for the network as a whole. The selection of new values for the high usage trunk group sizes, to

start a new iteration, has been dependent on heuristic procedures. The point-to-point blocking functions developed by Blaauw and extensively used in the constraint set of his mathematical programming problem are not exact.

The solution procedures of Blaauw and Pratt [26] may be considered as dual methods since during one iteration Pratt fixes the backbone part of the network to optimize the high usage part. Pratt utilizes the decomposition concept in the solution procedure which is circuit based. The optimization equations for the high usage trunks are formulated by differentiating the total cost function with respect to each independent variable. The backbone part of the network is fixed by selecting initial values for the blocking probabilities of the links forming the backbone. Pratt's model assumes that traffic other than that originated at a node and destined for another node is background traffic which is constant. Therefore, the variation in the number of trunks for the link under consideration is solely due to the variation in the related high usage traffic values. Pratt's method has been widely employed to dimension actual telephone networks, like in the French PTT program. One disadvantage of this method is that it does not guarantee the point-to-point grade of service constraints to be always satisfied. The models due to Berry and Blaauw do not possess this shortcoming. On the other hand, in terms of CPU-time Pratt's model seems to be tentatively the most advantageous between the three methods, to be followed by Blaauw's model.

The third extension of the ECCS-method, introduced by Rapp [27] and Eisenberg [8], involves the incorporation of traffic overflows and constraints on the blocking probabilities for more than one time of the day in the same cost minimization model. With this extension the new method obtained, commonly known as the multihour engineering method, differs from the ECCS-method. Only when the peak load hours on most of the routes coincide, the multihour engineering method reduces to the ECCS-method. By this new procedure, networks are engineered for more than one hour of point-to-point traffic data. Therefore, multihour engineering is a technique for designing trunk networks when the hours of peak traffic loads between various pairs of switching centers do not coincide.

Although the underlying theoretical basis for multihour engineering has been developed by Rapp, he proposed an approximate technique rather than attempting

to construct an optimal solution. Eisenberg [8], aiming to get an exact solution, concentrated his studies on a network structure where only one overflow possibility is accommodated. The algorithm devised by Eisenberg optimizes the high usage trunk group sizes one at a time, in a fixed but arbitrary sequence until no further cost reductions can be obtained. It is reported that such an algorithm has the undesirable property that it does not generally converge to a unique solution [9]. It can converge to any one of a family of suboptimal solutions, depending on the initialization of the algorithm and on the specific order in which the calculations are performed.

To eliminate the disadvantage of Eisenberg's algorithm, Elsner [9] derived a descent-type computational algorithm for the multihour engineering problem. For the solutions, Elsner concentrates on the same network structure as considered by Eisenberg. The essential difficulty of the multihour engineering problem arises from the fact that the network cost function is not differentiable everywhere in its domain. However, the algorithm presented by Elsner is assured of convergence to the minimum cost noninteger solution by the convexity of the cost function and by the particular execution scheme of the search process. The noninteger minimum cost solution is subsequently rounded to the nearest allowable integer solution to give a realizable network.

For the cases examined by Elsner and Eisenberg, it is revealed that the utilization of the multihour engineering technique produced networks whose costs averaged approximately 7 percent below those achieved by the usage of single-hour methods. Even though the multihour engineering technique appears to promise considerable cost benefits in future network designs, a number of problematic aspects have to be settled before the technique can gain acceptability for use in the field. Some of these aspects include the determination of the number of hours to be used in the engineering of a network and the actual selection of those hours, the determination of how multihour engineering can be accomplished in a large scale network with more than one overflow alternative, and finally the determination of how the trunk administration will best be carried out in a multihour environment.

The model proposed by Kortanek, Lee, and Polak [16] can be applicable in both single-hour and multihour optimization problems. Their basic contribution is the introduction of a linear programming problem approximating the nonlinear

problem in the case of probabilistic demand, whereby creating stimulation for further research on linear programming approach. The fact that blocking probability curves are convex, proven by Messerli [17], is utilized in their formulation. In their study, it is shown that a different use of the classical concept of marginal capacity of an additional trunk at a prescribed blocking probability leads to a linear programming model which can be used to compute the sizes of the high usage trunk groups. This new approach permits direct application of duality theory and sensitivity analyses to the design of switched probabilistic telecommunication networks. The model is applied to a larger scale network than those exemplifying the preceding multihour engineering models, but still there is only one overflow alternative for a specific exchange pair. The researchers state their anxiety on the issue of whether the proposed linear program provides optimal solutions having integral numbers of high usage trunk group sizes. To ensure the applicability of linear programming approach, further research is required.

III.2. THE DETERMINISTIC APPROACH TO SWITCHING NETWORK OPTIMIZATION PROBLEM

Considering the demand as deterministic rather than probabilistic constitutes the basis of the second major approach to the switching network design problem. This approach was introduced by Kalaba and Juncosa [14] in 1956. Their study is based on a linear programming model for a classical routing problem having variable link capacities. In spite of severe deterministic assumptions, the pioneering linear programming model of Kalaba and Juncosa can theoretically accommodate all conceivable routing possibilities since their traffic variables are indexed by an origin-destination point pair and also an intermediate switching point over all possible triads. The traffic parcels being deterministic in the Kalaba-Juncosa model signify that traffic originated at a certain junction and terminating at another junction is a given constant. Specifications for ensuing future periods are possible, but multihour considerations have not been incorporated to their formulation.

About 5 years after the Kalaba-Juncosa model, a series of papers written by Gomory and Hu on communication network flows are reported to have appeared in the SIAM Journal [16]. Their work, occurring over a 4-year period, significantly expanded the size of the linear programming network models that could be treated

computationally. They were able to combine features of generalized linear programming decomposition techniques with efficient Ford-Fulkerson methods for solving network subproblems. Gomory and Hu also stressed the importance of including communication demands indexed by time, such as time of day. They proceeded under the expected assumption that the time variable assumes only a finite number of values, but alternatively one can employ a continuous load curve with time-of-day varying demand.

III.3. THE OVERVIEW OF THE SWITCHING NETWORK OPTIMIZATION PROBLEM

Based on discussions with engineers in the field, Kortanek, Lee, and Polak report that both the deterministic and the probabilistic approaches have had significant impact in the actual design of switching networks. The completely deterministic approach has been found particularly important in delineating first choice and alternate routes between pairs of junctions, to be used in defining a network hierarchy. Once a network hierarchy is established, economies of scale are then achievable according to the optimal use of the underlying probability distributions of originating and alternately routed customer traffic.

III.4. APPROACHES TO THE CALCULATION OF BLOCKING PROBABILITY

The calculation of congestion is essentially inseparable from the switching network optimization problem, yet due to its significance and complexity, it has been a considerable research area by itself. The cost saving implications of an accurate computation of blocking probabilities in network design are enormous since the marginal link dimensioning conditions usually require the calculation of finite differences of blocking probabilities. Investigations concerning the blocking probability of individual parcels have been made by Wilkinson [34], Katz [15], and more recently by Deschamps [7].

Although most of the current switching network optimization procedures only ensure that the prescribed blocking levels be met on final trunk groups, recently the necessity of satisfying end-to-end blocking probability constraints is emphasized [13]. Individual trunk blocking levels may not be indicative of end-to-end congestion levels. High blocking on final groups may not necessarily imply the existence of a call congestion problem for the overall system while

significant end-to-end congestion may exist even though most final trunk groups are experiencing relatively low blocking levels. Thus, it is suggested that the procedure for measuring and specifying the traffic grade of service should be based on an end-to-end connection probability. However, the exact computation of end-to-end congestion is extremely complex because the routing of a call is usually selected from many alternate paths.

The conventional method, first presented by Lee [24] in 1955, is the construction of a probability linear graph and then the tracing for all paths connecting every origin-destination node pair. Such a solution for large scale networks with more than simple two or three link arrangements can obviously be impractical. Basically utilizing the same approach, Blaauw [3] has derived recursive relations to automate the tracing phase of the solution procedure. Through the recursive relations, it is expressed that with a small error, the end-to-end blocking probability can be written as a linear function of the blocking probabilities of the hierarchical trunk groups. The coefficients of the recursive relations are solely dependent on the blocking probabilities of the high usage trunk groups, therefore are known beforehand.

Deviating from the conventional use of a probability linear graph, Deschamps [7] presented an algorithm based on the analytic approximation method of Katz. The new algorithm, being recursive rather than iterative, introduces two new features which take theoretical results into account. Estimates of the covariances between different traffic parcels and between overflow and carried portions of traffic are considered, and formulas are used to find the blocking probabilities of first-routed traffic. Fundamentally, the end-to-end blocking probability is approximated by summing the losses over all final links and over all parcels for each route and then dividing this value by the offered traffic of the particular route.

On the other hand, Gaudreau [11] devised an algorithm which is not susceptible to any of the explicitly made calculations of the procedure due to Deschamps. The recursive formulae presented by Gaudreau generate all the required paths without making use of a probability linear graph. In this method, the end-to-end blocking probabilities are expressed as functions of the individual link blocking probabilities, so that for the applicability of the algorithm link blocking probabilities, implying the number of trunks on each link, have to be

known in advance. A new contribution of this algorithm is its capability to take into account switch blocking probabilities, if necessary, in the overall calculation. Extensions of Gaudreau's work to more general routing schemes have been carried out by Chan [5].

CHAPTER IV DEFINITION OF THE PROBLEM

IV.1. CHARACTERISTICS OF THE PROBLEM

The switching network is represented by a weighted directed graph to facilitate the formulation of the mathematical method for dimensioning the network with capital investment planning purpose. The nodes of the graph designate switching centers while the links stand for circuits. The weight associated with a link is the cost factor, which expresses the costs per circuit for that specific link.

The problem to be solved is a hierarchical network optimization where demand is probabilistic. The existence of blocking on each link necessitates special analysis to obtain the specified service values between each exchange pair. The objective is to obtain the number of circuits between each switching center while minimizing total investment cost and meeting the overall grade of service criteria. In the mathematical model, the definition of investment cost is limited to the incremental cost of providing a trunk on the direct link between two exchanges and the incremental cost of providing a trunk along the uniquely specified alternate route(s) connecting the two switching centers. In addition to the cost per circuit for each link, the unit switching investment cost per erlang is included to the cost value as a crude approximation for switching investments stemming from switching calls from one trunk group to another. Grade of service criterion, the crucial aspect of the problem besides cost minimization is a broad term that specifies the overall network behavior as experienced by the customer. In engineering terms it depends on service unavailability, network resilience, reliability, and transmission performance [6]. The mathematical model to be constructed for switching network optimization encompasses grade of service criteria depending only upon service unavailability under normal conditions. In the solution procedure of the thesis, the point-to-point blocking probabilities are calculated, instead of resorting to the easier method of

considering final link blocking probabilities, to represent the grade of service value. Therefore, a contribution is made on the subject of ensuring grade of service values, as many recent researchers emphasize but very few existing dimensioning procedures fathom.

The necessary data and parameter inputs for the mathematical model are as follows:

- i) The description of the switching network in terms of the location and number of exchange nodes and tandem nodes with their specific hierarchies.
- ii) Routing rules to enable signifying distinct routes for each exchange pair.
- iii) Traffic matrix representing the amount of forecasted or estimated traffic flow values between each exchange pair.
- iv) Cost parameters which roughly depend on distance, number of subscribers, and the number of circuits.
- v) Grade of service parameter to be met under normal conditions.

The determination of the aforementioned data, being a tough job requiring thorough scrutiny and care, is a subject on which many researchers are working, but it is excluded from the content of the thesis. It is assumed that the input requirements of the dimensioning method are available.

The direct outputs of the dimensioning method are the sizes of each trunk group and the approximate cost of the switching network. The by-products of the method are the amount of transit traffic at tandem nodes, the realized traffic routes for each traffic relation, the final link blocking probabilities, the grade of service achieved for each traffic relation, and some marginal parameters like marginal overflow and marginal occupancy.

Theoretically, the dimensioning method of the thesis is capable of engineering networks with overflow possibility number being higher than one for each exchange pair. As an application, the overflow possibility number is chosen to be at most two. Considering the fact that most of the dimensioning procedures

are based on one overflow possibility, another contribution of the thesis results.

IV.2. EXAMPLES ON NETWORK STRUCTURE

To clarify the characteristics of the problem and to depict the distinct routing hierarchy considered in this study, a simple illustration may be helpful at this stage. The following elementary network can lay the foundations of the test network to be utilized and introduced in Chapter VI.

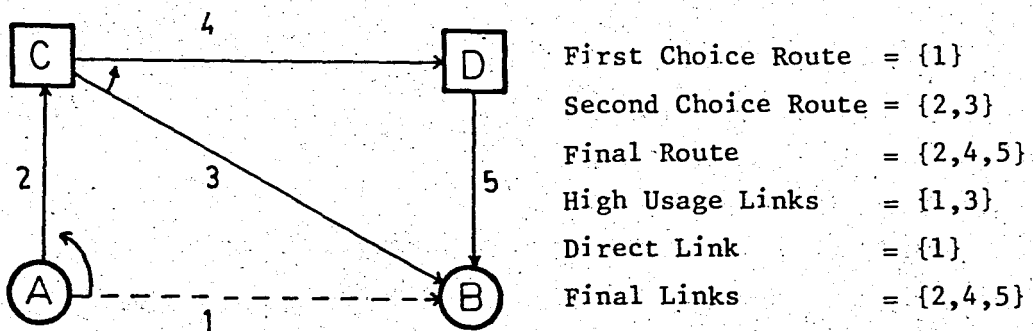
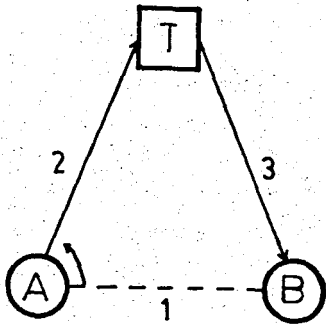

Figure IV.1. Basic Routing Pattern

In Figure IV.1, there is only one exchange pair. Calls are processed from node "A" to node "B" with or without the utilization of the two tandem nodes denoted by "C" and "D". The example network has two overflow possibilities; thus, it has two alternate routes beside the direct connection. Due to topological conditions, in some cases the construction of the high usage links may not be physically viable. The dimensioning theory can deal with such situations by directly supplying the traffic flows to the alternate route. Moreover, the solution procedure is accommodated to handle cases where one or more high usage link(s) result to be totally uneconomical after applying the dimensioning method. The illustrated graph is directed since the incoming and outgoing calls are transmitted through separate links.

While planning the switching network investment, the decision maker may wish to

compare and evaluate a network structure containing only one overflow possibility for each exchange pair with the previously described more complex routing pattern.



First Choice Route = {1}
Final Route = {2,3}
Direct Link=High Usage Link = {1}
Final Links = {2,3}

Figure IV.2. Triangular Routing Pattern

To help making comparisons, it is found useful to include also the triangular routing pattern. Within the solution procedure and the computer programs, provision is made for such an option, as will be elaborated in the following sections. The simplest portion of a network with triangular alternate routing pattern, having only one exchange pair, is delineated by Figure IV.2.

CHAPTER V FORMULATION

V.1. FUNDAMENTAL THEORIES UTILIZED IN THE SOLUTION PROCEDURE

In the formulation of the switching network optimization problem, two theoretical concepts are extensively used. Most of the formulae and relations, employed in dimensioning the final links of the network, are closely dependent on the two theoretical concepts, namely the Erlang-B formula and the "Equivalent Random Theory" (ERT).

V.1.1. THE ERLANG-B FORMULA

Various mathematical formulae, called trunking formulae, have been developed by mathematicians from which the quantity of service channels can be determined. Trunking formulae can be divided into two main categories as those applying to the case of "full availability" and those applying to the case of "limited availability" [22]. The definition of full availability is given by the Nomenclature Committee of the Fifth International Teletraffic Congress, 1967, Item number 1133:

"Full availability exists when any free inlet can reach any free outlet of the desired route regardless of the state of the system."

This definition clearly implies that full availability means zero internal blocking, so a more expensive switch than that which can be used under limited availability is required.

The Erlang-B formula, known also as the Erlang loss formula, is a full availability trunking formula. The factors affecting the variation in the trunking formulae, chosen for application, are mainly the distribution of the input

traffic and call holding time, the number of originating traffic sources, and the method of dispensing with lost calls.

The input traffic can be smooth, random, or rough (peaked) characterized respectively by the binomial, Poisson, or the negative binomial formulae. Theoretically, the call holding time distribution may either be constant or follow the negative exponential law. The number of originating traffic sources can either be limited or infinite. It is expressed that in link systems, such as crossbar or crosspoint systems, where the subscribers' lines are arranged in small line groups, having 50 lines or less in a line group, the assumption of limited traffic sources implying smooth traffic, is usually applied [22]. On the other hand, in step-by-step systems where the subscribers' lines are arranged in groups of 100 lines or more, the assumption of infinite sources, implying random traffic is applied.

The differences of the trunking formulae depend to a large extent on the assumption with which lost calls, which arise when all the service channels are occupied, are dealt with. The three assumptions related with dispensation are named lost-calls-cleared (LCC), lost-calls-held (LCH), and lost-calls-delayed (LCD). The LCC assumption is valid when the users are patient. The patient user, when receiving the busy signal indicating that all of the channels are busy, hangs up and tries to place the call later on, probably when the congestion period is over. Such lost calls disappear from the system with zero holding time if the time to set-up the call is neglected. The LCH assumption, on the other hand, denotes the impatient user. In this case, on receiving the all channels busy signal, the calling party continues to retry his call immediately while the congestion period is still prevailing. The third assumption concerning dispensation, LCD, applies to waiting systems such as dial-tone service and calls to operators where the caller waits for service. In this case, theoretically the delay can be infinite. In almost all countries, excepting the U.S., the LCC assumption underlies the trunking formulae used.

Having described the different assumptions of the trunking formulae in general, at this stage the underlying specific assumptions of the Erlang-B formula can be set and evaluated.

i) Traffic originates from an infinite number of traffic sources, implying

Poisson traffic input.

The assumption of an infinite number of originating sources implies an infinite number of call arrivals, each with an infinitely small holding time. To apply this assumption to real traffic, it has to be further assumed that the conversation time of one subscriber is composed of elementary short calls originated by different subscribers [21]. Moreover, this assumption implies that the probability of call arrivals is constant and does not depend on the state of occupancy of the system, which is not really true. In the extreme case, supposing that half of the subscribers are conversing with the other half, then the arrival of another call is impossible. Thus, clearly the probability of a call arrival depends on the state of the system. Therefore, although random traffic is rarely found in practice, due to the simplicity of its characteristic function, it has been used as the input process in classical traffic theory.

ii) Number of service channels is limited. Considering real systems, this assumption is obviously valid.

iii) Lost calls are cleared from the system with zero holding time.

This is the LCC assumption previously explained. Supposing that the system is not a waiting system, then for evaluation purposes, the LCC assumption needs to be compared with the LCH assumption. Although there are impatient users, implied by the LCH assumption, who have the habit of continuing to redial the unsuccessful calls immediately after receiving the busy signal, in the hope that a gap can be found, the standards of service are not set for such very impatient users. The impatient user can be thought as a traffic violator who does not wait while the red stop light is prevailing [22]. Therefore, the LCC assumption provides a better criterion for the administration of service than the LCH assumption.

iv) The Erlang-B formula is expressed to be valid for any distribution of call holding time [22].

The Erlang-B formula, encompassing the four basic assumptions, is expressed mathematically as follows, [22].

$$B(N,A) = \frac{A^N / N!}{\sum_{j=0}^N A^j / j!} \quad (V.1)$$

The value of the Erlang-B formula represents the link blocking probability or the probability of congestion. The derivation of the Erlang-B formula is closely related to the Erlang distribution given by expression (V.2), [22].

$$B(Y,N,A) = \frac{A^Y / Y!}{\sum_{j=0}^N A^j / j!} \quad (V.2)$$

The Erlang distribution represents the probability of finding Y calls in progress simultaneously. The Erlang distribution is a truncated Poisson distribution whose tail is cut at the value of N. For Poisson traffic input, the call and time congestions are equal. As call congestion, the value of equation (V.1) gives the proportion of lost calls or the proportion of calls which fail at first trial. As time congestion, it represents the proportion of time during which all the channels are simultaneously busy.

V.1.2. THE EQUIVALENT RANDOM THEORY (ERT)

The equivalent random theory, developed by Wilkinson, provides an approximate method for estimating the number of trunks required to handle peaked traffic loads. Overflow traffic, which is rough (peaked), is offered to other links in a network with alternate routing possibility. However, the assumptions made in the derivation of the Erlang-B formula clearly express that the input traffic should be random, as was stated in the previous section. If the Erlang-B formula is used when the input traffic is rough, then an underestimation of the link capacities results. In such cases, the ERT is applied to obtain more reliable results.

The basic objective of the ERT is to express the nonpoisson input traffic in terms of its equivalent Poisson parameters so that the Erlang-B formula can be

used correctly. Considering Figure V.1, the objective is to express M and V in terms of Poisson parameters.

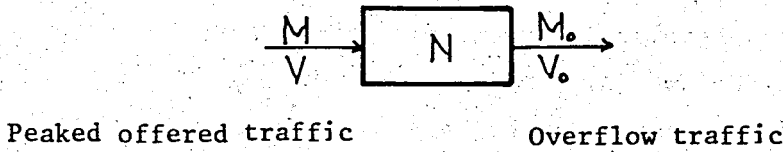

Figure V.1. Representation of a Link Requiring ERT

Within the ERT, it is assumed that the traffic offered to the link under consideration is that traffic which overflows an imaginary link with an imaginary number of trunks when it is offered an imaginary amount of random traffic to result in overflow traffic equivalent to the peaked traffic offered to the specific link considered. In essence, the underlying assumption of the ERT is illustrated by Figure V.2.

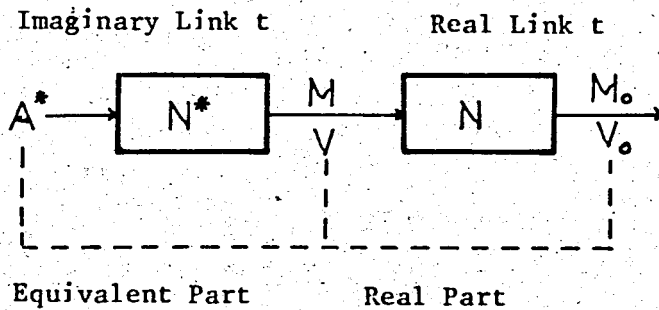

Figure V.2. Representation of a Link Under ERT

The basis of Wilkinson's model is that the rough traffic (M, V) may be regarded as overflowing from an equivalent group of N^* circuits which are offered an equivalent random traffic A^* . To obtain the values of N^* and A^* , Wilkinson has derived the following two formulae.

$$M = A^*B(N^*, A^*) \quad (V.3)$$

$$V = M \left(1 - M + \frac{A^*}{N^* + 1 - A^* + M} \right) \quad (V.4)$$

where,

$B(.,.)$ is the Erlang-B formula and
M and V are of known values.

The underlying logic of expression (V.3) is that the amount of overflowing traffic can be found by multiplying the amount of offered traffic with the link blocking probability. The proof of expression (V.4), which is the formula for calculating the variance of overflow traffic, is given by Wilkinson in Reference [34].

Solving for A^* and N^* by the use of formulae (V.3) and (V.4) is obviously tedious. In the thesis, for solution purposes the approximations due to Rapp are used. Rapp's approximate expressions are given by (V.5) and (V.6).

$$A^* \cong V + 3 \frac{V}{M} \left(\frac{V}{M} - 1 \right) \quad (V.5)$$

$$N^* \cong \left(\frac{M + \frac{V}{M}}{M + \frac{V}{M} - 1} \right) A^* - M - 1 \quad (V.6)$$

V.2. ASSUMPTIONS OF THE MODEL

In addition to the assumptions of the Erlang-B formula, presented in section IV.1.1., the following are included within the assumption set of the developed dimensioning method.

- i) Variations in the number of trunks for the link under consideration are only due to the variation of the high usage traffic values. The direct implication is that when optimization procedures are applied, any variation in the number of circuits on a specific link, shared by several traffic parcels, is due solely to the variation in the values of traffic overflowing from the relevant high usage link. This assumption, named as constant background traffic [12], underlies Pratt's method of dimensioning.
- ii) No traffic is offered to the direct links from other trunk groups so that the traffic input of the direct links is random.

- iii) Smooth traffic is approximated by random traffic giving rise to overdimensioning within the theoretical model as compared to real-life actualization.
- iv) In switching network optimization problem, reliability under abnormal conditions is not aimed to be guaranteed so that protection measures such as explicit overdimensioning, diversification, and use of stand-by equipments [6] are not included to the model. It is assumed that the value and choice of protection measures are to be determined after the solution of switching network optimization problem before proceeding with transmission network optimization problem for the overall optimization of a telecommunication network.
- v) The optimization of the trunk group sizes is to be made without taking account of modularities.
- vi) The total cost function, which is defined in section V.3.2.1, is constructed without considering the possible existing erlang capacity of the tandem switches. It is assumed that for comparative purposes, the switching cost function can be approximated.
- vii) The trunk group capacity sizes, which are calculated as real numbers, are rounded-off to yield integral values.

V.3. METHODOLOGY

The mathematical formulation of switching network optimization in closed form is given by Blaauw [4].

$$\min \left[\sum_{k \in F_k} C_k \cdot N_k(A_k, b_k) + \sum_{\ell \in F_h} C_\ell \cdot N_\ell \right] \quad (V.7)$$

subject to

$$E_j(b_k, \forall k \text{ used by } j) \leq E_{\max} \quad \forall j \quad (V.8)$$

$E_j(\cdot)$, employed within the constraint set, are the recursive formulae of Blaauw to represent the end-to-end blocking probability, which is dependent on the individual final link blocking probabilities, for each calling pair j . The model given by (V.7) and (V.8) is formulated in terms of blocking probability and circuit requirement variables. The necessary decompositions to solve this problem can be found in Blaauw's paper [4]. This model will not be further discussed since the mathematical model of the thesis is based only on circuit requirement variables. Blaauw's model is included to present a closed form of a switching network optimization problem since a neat closed form of formulation based explicitly on circuit requirements is hard to supply.

V.3.1. INITIALIZATION

The switching network, to be optimized, is split into a high usage and a backbone part. In performing the calculations, the choice sequence of the links is vitally important because the dimensioning of a certain link depends upon the information considering the previous links. For example, links which are offered fresh traffic must be calculated before the links which are offered degenerate overflow traffic. Thus, the computations are carried out by considering the hierarchy of the nodes and the network structure.

The functioning of the dimensioning procedure, which is fundamentally based on economic criteria for high usage links and blocking constraints for final links, will be described in terms of three different link types: High usage links, links which are offered overflow traffic, and links which are offered the carried traffic of the link(s) just preceding them. To differentiate these three link types more clearly, it is helpful to consider the simple network of Figure IV.2. In the triangular network, link 2 is the link which is offered the overflow traffic of link 1 while link 3 is the link which is offered the carried traffic of link 2. Even though links 2 and 3 are both final links, due to the existence of final link blocking probabilities and the differences in calculating their offered traffic values, such a differentiation is essential for the application of the dimensioning procedure.

In addition to initialization concerning the network structure, parametric initializations are required. The marginal occupancy, H , of a link is a function of the marginal capacity, β , and marginal overflow, γ , parameters of the links in the rest of the network, as can be observed through the equations in

Appendix A.I. However, the β and γ parameters cannot be calculated until the value of H for the overflowing link is known. To resolve this apparent dilemma, an iterative method of solution is required. To initiate the iterative procedure, β and γ are initialized with typical starting values for β and γ , being in the ranges 0.7-0.8 and 0.6-0.8, respectively [26]. Another iteration is implied since the final link blocking probabilities have to be preassigned. The dimensioning of the final links is directly dependent on their blocking probability values. Preferably but not necessarily, as will be elaborated in section IV.3.8, the initial final link blocking probability values are chosen so as to satisfy the imposed grade of service parameter.

V.3.2. DIMENSIONING OF HIGH USAGE LINKS

V.3.2.1. The Optimization Problem

It should be noted that throughout the optimization problem any one of the quantities N, a, A_c , b is a function of two independent variables under the specified routing conditions. Deleting the link subscripts, the following can be taken as examples.

$$N = N(A, a)$$

$$a = a(A, N)$$

$$A_c = A_c(A, a)$$

$$b = b(A, N)$$

In the thesis, for the dimensioning of high usage links, Pratt's method is used [26], [31]. Omitting the link subscripts, the following definitions, originally due to Pratt, are extensively utilized within the dimensioning procedure.

$$\text{Marginal Occupancy} = H = \left(\frac{\partial A_c}{\partial N} \right)_A = - \left(\frac{\partial a}{\partial N} \right)_A$$

The marginal occupancy (marginal efficiency) of a link represents the additional traffic which may be carried on it per unit increase in its circuits, at constant offered traffic. Conversely, the decrease in the overflowing rejected traffic per unit increase in circuits is measured by the marginal efficiency.

$$\text{Marginal Capacity} = \beta = \left(\frac{\partial A}{\partial N} \right)_b$$

The marginal capacity of a final link represents the additional traffic which may be offered to it per unit increase in its circuits, at constant congestion level.

$$\text{Marginal Overflow} = \gamma = \left(\frac{\partial a}{\partial A} \right)_N$$

The marginal overflow parameter represents the rate at which traffic overflows from a link at constant size that is subjected to changes in offered traffic.

To represent the optimization problem for the circuit based switching network, initially the total cost has to be expressed in terms of the decision variables and parameters of the problem.

$$C = \sum_{\ell \in F_h} C_\ell \cdot N_\ell + \sum_{k \in F_k} C_k \cdot N_k + \sum_{i \in F_i} C T_i \cdot T_i \quad (V.9)$$

The objective is to determine suitable values for all the variables denoted by N_ℓ , N_k , and T_i , subject to the overall grade of service constraints. The cost function, C , is a function of L independent variables representing the high usage links since the determination of N_ℓ determines the overflow, a_ℓ and hence the variables T_i and N_k based on the specified final link blocking probabilities.

Fundamentally, the dimensioning of the high usage links is dependent on the cost ratio of the high usage link and the relevant final link set. The end-to-end blocking probability constraints for each relation are guaranteed to be satisfied by the dimensioning of the final links. The first necessary condition that must be satisfied to evaluate the minimum network cost is that the first derivative of the cost function, C , with respect to the independent variables, N_ℓ , must be zero. Naturally, the other necessary and sufficient conditions for optimality concerning the signs of the second or higher order derivatives must be fulfilled. Thus, the minimum network cost is found by solving the set of L

optimization equations, corresponding to the L independent variables.

$$\left(\frac{\partial C}{\partial N_\ell} \right)_{\{N_n\}} = 0 \quad \forall \ell \in F_h, n \in F_h, n \neq \ell \quad (V.10)$$

To obtain the partial derivatives of (V.10), chain rule is used. The explicit mathematical form of the final links as a function of the high usage links is not available. However, the resulting partial derivatives are in such forms that direct substitution of the previously defined marginal parameters is viable.

Pratt [26] has shown that equations (V.10) can be represented in a closed form, as paraphrased by expression (V.11).

$$\frac{C_\ell}{H_\ell} = \sum_{k \in F_\ell} \frac{C_k}{\beta_k} \cdot XT_k + \sum_{i \in F_i} CT_j \cdot Y_i \quad \forall \ell \in F_h \quad (V.11)$$

The computation of the partial derivatives and the underlying reasoning of equation (V.11) are presented in Appendix A separately for the two networks of Figure IV.1 and Figure IV.2. At this point, to illustrate how the marginal parameters appear in the open form of equation (V.11), the following expressions can be helpful. For the triangular network of Figure IV.2, the following equations are obtained.

$$\frac{C_1}{H_1} = CD_1 \quad \text{where,}$$

$$CD_1 = \frac{C_2}{\beta_2} + \frac{C_3}{\beta_3} + CT_T \quad (V.12)$$

For the more complex network of Figure IV.1, the following are realized.

$$\frac{C_1}{H_1} = CD_1 \quad \text{where,}$$

$$CD_1 = \frac{C_2}{\beta_2} + \frac{C_4}{\beta_4} \cdot \gamma_3 + \frac{C_5}{\beta_5} \cdot \gamma_3 + CT_c + CT_d \cdot \gamma_3 \quad (V.13)$$

It should be noted that while the simple triangular network requires only the concepts of marginal efficiency and marginal capacity, the more complex network requires the additional concept of marginal overflow.

V.3.2.2. Economic Criteria

There are two economic criteria to be checked, based on the cost ratio and the calculated marginal efficiency parameter for the routing of traffic on a high usage link. Equation (V.12) is the optimization equation for the basic triangular pattern. It represents the minimum network cost condition that occurs when the cost of carrying one additional traffic unit (marginal cost per erlang) on the high usage link is equal to the marginal cost of one traffic unit overflowing to the final choice tandem network [31]. Similarly, equation (V.13) is the optimization equation for the basic network of two overflow possibilities. Based on this interpretation of the optimization equation, then the high usage link would only be viable if,

$$\frac{C_1}{CD_1} < 1$$

Hence, if $H_1 < 1$

For any switching network, the initial economic test can be formalized to be as (V.14). The high usage link ℓ would be viable if,

$$\frac{C_\ell}{CD_\ell} < 1 \quad \text{i.e.,} \quad H_\ell < 1 \quad (\text{V.14})$$

H_ℓ , in this context, measures the cost ratio of routing the required traffic over the high usage link ℓ as compared to the rest of the network. If $H_\ell > 1$, then that high usage link ℓ should not be constructed.

Assuming that the first economic criterion is satisfied, meaning that the value of the marginal efficiency parameter calculated by using equation (V.11) is less than unity, then it is required to determine the type of traffic offered to that high usage link. If the traffic is non-Poissonian, then a further economic criterion is calculated by using the equivalent link parameters A^* and N^* calculated by the use of ERT. This criterion establishes a limit on the marginal efficiency, H_{Lim} , of a link which is offered degenerate traffic, where

$$H_{Lim} = A^*[B(N^*, A^*) - B(N^*+1, A^*)] \quad (V.15)$$

The second economic criterion is expressed as [31]:

$$H_{\ell} < H_{Lim}^{\dagger} \quad (V.16)$$

H_{Lim} measures the change in traffic overflowing from the equivalent link when the latter is incremented by one circuit. Sheridan [31] states that H_{Lim} is a measure of the sensitivity of the degenerate traffic, rejected from the equivalent link. To justify routing traffic on link ℓ , inequality (V.16) must be satisfied. Traffic failing to satisfy inequality (V.16) will not be routed on link ℓ .

V.3.2.3. The Relationship Between the Marginal Efficiency Parameter and the High Usage Link Sizes

Having obtained the numerical values of the marginal efficiency parameter for each high usage link, it is necessary to translate the parameters into quantities of circuits on the links. The transformation is made by utilizing the definition of the marginal efficiency parameter. Since the marginal efficiency parameter indicates the decrease in overflow traffic per unit increase in circuit number under constant offered traffic, it can be represented as in equation (V.17).

$$H = - [A \cdot B(N+1, A) - A \cdot B(N, A)] \quad (V.17)$$

Equation (V.17) is replaced by an equivalent expression given by (V.18).

$$H = A [B(N, A) - B(N+1, A)] \quad (V.18)$$

Two problems may arise while using expression (V.18) to solve for N , given the amount of offered traffic and the calculated value of the marginal efficiency

† From this point onwards, the subscript " ℓ " will be omitted in presenting the formulae, but it should be remembered that all the formulae apply linkwise.

parameter. If the input traffic is rough, then as previously explained in sections V.1.1 and V.1.2, the ERT has to be applied prior to the usage of the Erlang-B formula which appears twice in expression (V.18). Then equation (V.18) may be rewritten as in (V.19).

$$H = A^* [B(N^*+N, A^*) - B(N^*+N+1, A^*)] \quad (V.19)$$

Having calculated the values of A^* and N^* by applying equations (V.5) and (V.6), and knowing the numerical value of H from equation (V.11), the value of N can be obtained by using expression (V.19) within an iteration scheme. Equation (V.19) is the general form of defining the marginal efficiency parameter. If the input traffic is not rough, then by equating N^* to zero and taking the input traffic value as A^* , equation (V.19) is still applicable.

Thus, the first problem which can arise while utilizing expression (V.18) is resolved by replacing it with equation (V.19). The second application problem arises since the Erlang-B formula is defined for only integer valued N . Within the iteration scheme to achieve N through the usage of equation (V.19), equality can be guaranteed only if the link sizes are real valued. To resolve the problem of convergence for link sizes when using the value of the marginal efficiency parameter, $B(.,A)$ is replaced by a polygonal function $\hat{B}(.,A)$ as defined by (V.20), [16].

$$\hat{B}(X,A) = -D(N,A)X + (N+1)B(N,A) - N B(N+1,A) \quad (V.20)$$

for $N = 0, 1, \dots$

where $B(0,A) = 1$

$$D(N,A) = B(N,A) - B(N+1, A)$$

N is the integer part, $[X]$, of X .

For each nonnegative integer N , $D(N,A) > 0$. Messerli [17] gives a proof that for any fixed $A > 0$, $D(N,A)$ is strictly decreasing in the nonnegative integer variable N ,

$$D(N+1, A) < D(N,A) \quad N=0, 1, \dots$$

It should be noted that

$$\hat{B}(R,A) = B(R, A)$$

for each nonnegative integer R .

The polygonal function $\hat{B}(\cdot, A)$ is achieved by fitting a line between each two consecutive points, defined by the integer valued Erlang-B formula. The derivation of (V.20) is trivial; however, for the sake of completeness it is included in Appendix B. The convexity and monotonicity properties of the polygonal function $\hat{B}(\cdot, A)$ is revealed by the graph illustrated in Figure V.3, which is originally given in Reference [16].

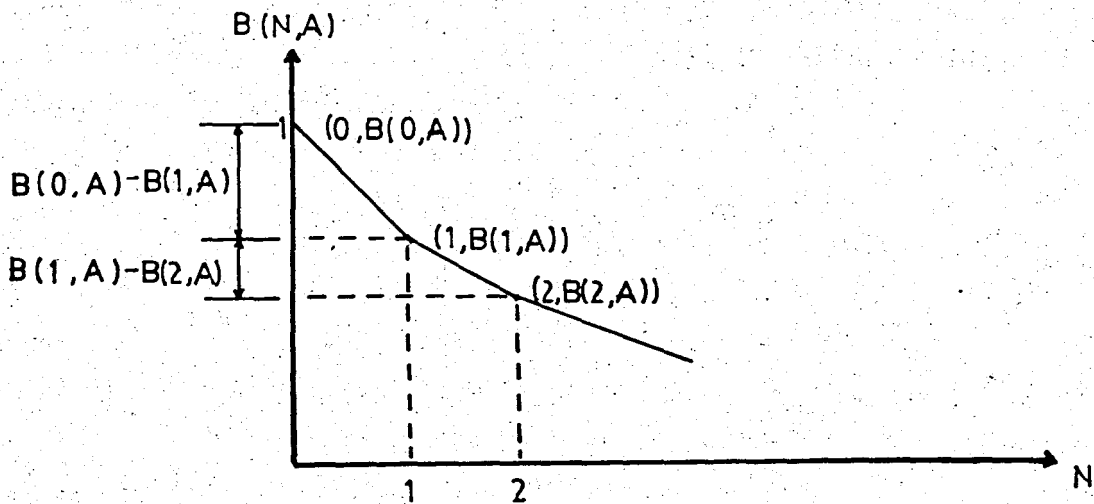

Figure V.3. The Polygonal Function Determined by the Erlang-B Function on Nonnegative Integers

Equation (V.20) is appealing due to its simplicity, but if necessary a more elaborate approximating function can be developed. In short, the second problem in applying equation (V.18) is overcome by substituting $\hat{B}(\cdot, A)$ for $B(\cdot, A)$. Therefore, by considering equations (V.19) and (V.20) simultaneously, the number of trunks to be provided for each high usage link can be attained.

V.3.3. DIMENSIONING OF LINKS WHICH ARE OFFERED OVERFLOW TRAFFIC

The traffic overflowing from the high usage links constitute the offered traffic to some of the final links in the network. To dimension such final links, the first step to be performed is to find the value of the offered traffic parcels

in terms of their mean and variance. Wilkinson [34] has derived the following two formulas to calculate the mean and variance of traffic overflowing from a certain link with N circuits.

$$M_o = A B(N,A) \quad (V.21)$$

$$V_o = M_o \left[1 - M_o + \frac{A}{N+1-A+M_o} \right] \quad (V.22)$$

Wilkinson has also shown that the negative binomial distribution, with two parameters chosen to agree with the mean and variance, gives a satisfactory fit to the distribution of traffic overflowing a group of trunks. Evidence is given that the principal fluctuation characteristics of overflow-type of non-random traffic are described by their mean and variance.

If the input traffic A is rough, then the ERT is applied prior to using equations (V.21) and (V.22), as the need was stressed in section V.1.2. Since the link, whose overflowing traffic is sought, has been dimensioned, the value of N for that high usage link is known. Then, proceeding in the right-hand side direction of the ERT representation of a link given in Figure V.2, the structure depicted in Figure V.4 is obtained.

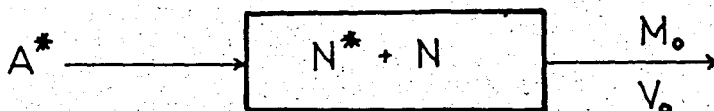

Figure V.4. Closed Form Representing a Link After the Application of ERT

It is now assumed that the equivalent random traffic A^* is offered to a link whose number of circuits equal (N^*+N) to produce M_o and V_o [34]. Using equations (V.21) and (V.22) with the equivalent random parameters, the following two equations result to calculate the individual overflow traffics from the relevant high usage links.

$$M_o = A^* B(N^* + N, A^*) \quad (V.23)$$

$$V_o = M_o \left(1 - M_o + \frac{A^*}{N^* + N + 1 - A^* + M_o} \right) \quad (V.24)$$

It is now possible to obtain the combined overflow traffic, which is really the offered traffic to the final link to be dimensioned. Since the overflows of the high usage links are independent of one another, the i -th semi-invariants of the individual overflows can be combined to give the corresponding semi-invariants of their total. In terms of the overflow means and variances, the corresponding parameters of the combined loads are expressed by adding the individual means and variances corresponding to the high usage links which overflow to the final link under study.

The combined overflow traffic is really the offered traffic to the considered final link. Therefore, the offered traffic in terms of its mean and variance has been calculated. Since overflow traffic is peaked, the variances of each individual overflowing traffic parcels will be greater than their means. Then obviously, the combined overflow traffic will also exhibit a peaked nature. The ERT is applied to attain the equivalent random parameters characterizing the rough offered traffic before the final link is dimensioned. A^* and N^* are calculated by using equations (V.5) and (V.6) since the values of M and V for that final link are now known. Then, through the usage of the approximate polygonal form of the Erlang-B formula, the value of N is obtained by an iterative scheme. It should be noted that the blocking probability for each final link had been prespecified so that while computing N , the value of $\hat{B}(\cdot, A^*)$ is taken as input. The iterations to obtain N are based on expression (V.25) which follows directly from (V.20).

$$\begin{aligned} \hat{B}(X^*+X, A^*) = & - D(N^*+N, A^*) (X^*+X) + (N^*+N+1) B(N^*+N, A^*) \\ & - (N^*+N) B(N^*+N+1, A^*) \end{aligned} \quad (V.25)$$

where,

X^* is the real-valued equivalent number of trunks given by the real value which results from equation (V.6).

In expression (V.25), the values of $\hat{B}(\cdot, A^*)$, A^* , N^* , and X^* are known. Thus, the values of X and N can easily be found through iterations. Once N and X are known, it means that the final link is dimensioned.

V.3.4. DIMENSIONING OF LINKS WHICH ARE OFFERED CARRIED TRAFFIC

The final links, which are not offered overflow traffic, are offered the traffic carried by the final link(s) just preceding them. To dimension such final links, the first step to be performed is to find the value of the offered traffic parcels in terms of their mean and variance. Wilkinson [34] gives the following formulas to estimate the mean and variance of the carried load when a random traffic of A erlangs is offered to a group of N trunks, assuming that the overflowing calls do not return.

$$M_c = A[1 - B(N,A)] \quad (V.26)$$

$$V_c = M_c(1 - L_c) \quad (V.27)$$

where,

L_c represents the traffic load carried by the last trunk of the link and is expressed as in (V.28).

$$L_c = A[B(N-1,A) - B(N,A)] \quad (V.28)$$

As can be easily observed from equation (V.27) and as Wilkinson indicated, L_c can be written in terms of the variance-to-mean ratio (vmr) of the carried traffic.

$$L_c = 1 - \text{vmr}$$

In the cases where the offered traffic of the link, whose carried traffic is to be calculated, is rough, then equations (V.26) and (V.28) are rewritten by considering the application of the ERT.

$$M_c = A*[1 - B(N^*+N, A^*)] \quad (V.29)$$

$$L_c = A*[B(N^*+N-1, A^*) - B(N^*+N, A^*)] \quad (V.30)$$

Thus, by using equations (V.28), (V.29), and (V.30), the carried traffic of the relevant link is found in terms of its mean and variance. It is expressed that carried traffic is characterized by binomial distribution [34]. It is evident by considering equations (V.23), (V.24), (V.28), (V.29), and (V.30)

that the sum of the mean of the carried traffic and the overflow traffic is equal to the mean of the offered traffic; however, it is not so with the variances since there is dependence.

It is now possible to obtain the combined traffic which is really the offered traffic to the final link to be dimensioned. Since the traffics carried by different final links are independent from one another, their respective means and variances can be summed to obtain the mean and variance of the combined carried traffic. Thus, the value of the offered traffic to the final link to be dimensioned has been calculated. Since the variance of each individual carried traffic parcel is less than its mean, the combined carried traffic will also exhibit smoothness. Then, that final link is offered smooth traffic implying that the ERT is not required. To dimension such final links, the value of $\hat{B}(\cdot, A)$ is taken as input as was discussed in section V.3.3. The iterations to obtain N are based on expression (V.20) since in this case N^* and X^* are equal to zero.

V.3.5. UPDATING THE MARGINAL PARAMETERS

Once the dimensioning steps, explained through sections V.3.2 , V.3.3 , and V.3.4 , have been completed for all the links in the network the number of circuits to be provided for each link is obtained. As it was emphasized in section V.3.1 , the marginal capacity and marginal overflow parameters were given starting values to dimension the high usage links. Therefore, the dimensioning has to continue until these marginal parameter values and the associated network cost stabilize. In order to start a new dimensioning iteration to dimension all of the links again, the updated values of β and γ have to be known.

V.3.5.1. Updating the Marginal Capacity Parameter

To update the marginal capacity parameters of the final links, the following argument given by Sheridan [31] is used. By definition, the marginal capacity parameter can be expressed as in equation (V.31).

$$\beta = \left(\frac{\partial M}{\partial N} \right)_P \quad (V.31)$$

Consider a final choice link with N circuits, whose offered traffic has mean M and variance V. The loss experienced by (M, V) is P, where P is defined as follows [31].

$$P = P\left(M, \frac{V}{M}, N\right) = \frac{A^* B(N^*+N, A^*)}{M} \quad (V.32)$$

Since the marginal capacity, β , measures the additional traffic that may be offered to a final choice link when the latter is increased by one circuit and the loss probability held constant, β can be defined by the following equation.

$$P\left(M+\beta, \frac{V}{M}, N+1\right) = P = P\left(M, \frac{V}{M}, N\right) \quad (V.33)$$

The open form to find the updated β value, implied by equations (V.32) and (V.33) due to Sheridan [31], is paraphrased as equation (V.34).

$$\frac{A'^* B(N'^*+N+1, A'^*)}{M+\beta} = \frac{A^* B(N^*+N, A^*)}{M} \quad (V.34)$$

where,

A'^* is the equivalent random traffic corresponding to input traffic $(M+\beta)$.
 N'^* is the number of equivalent circuits corresponding to input traffic $(M+\beta)$.

The values of M, V, and N are known; therefore, A^* and N^* can easily be calculated by the use of equations (V.5) and (V.6). However, the value of A'^* and N'^* are dependent on the value of β . Consequently, equation (V.34) is not directly solvable for β . Within the computer program, the new value of β is found by an iterative technique similar to one dimensional search.

V.3.5.2. Updating the Marginal Overflow Parameter

The marginal overflow parameters of all high usage links excepting the direct links are utilized within the dimensioning procedure. To update the marginal overflow parameters, the following argument given by Sheridan [31] is used. The

marginal overflow of a link consisting of N^*+N circuits with offered traffic being A^* is expressed by (V.35), which follows directly from the definition of this parameter given in section V.3.2.1.

$$\gamma(A^*, N^*+N) = \left(\frac{\partial M_o}{\partial A^*} \right)_{N, N^*} \quad (V.35)$$

The right-hand side of equation (V.35) can be decomposed as in (V.36).

$$\left(\frac{\partial M_o}{\partial A^*} \right)_{N, N^*} = \left(\frac{\partial M_o}{\partial M} \right)_N \left(\frac{\partial M}{\partial A^*} \right)_{N^*} \quad (V.36)$$

Then, utilizing the definition of the marginal overflow parameter again, expression (V.37) is obtained from (V.36).

$$\gamma(A^*, N^*+N) = \gamma(M, V, N) \gamma(A^*, N^*) \quad (V.37)$$

Since N stands for the link being dimensioned with offered traffic (M, V) , its marginal overflow is as follows.

$$\gamma(M, V, N) = \frac{\gamma(A^*, N^*+N)}{\gamma(A^*, N^*)} \quad (V.38)$$

The marginal overflow terms on the right-hand side of equation (V.38) relate to Poisson traffic and thus are directly calculable. To calculate such terms expression (V.39), which is really the open form of the definition of marginal overflow parameter is used within the computer program.

$$\gamma(A^*, R) = (A^*+1)[B(R, A^*+1)] - A^*B(R, A^*) \quad (V.39)$$

At this stage, the values of A^* , N^* , and N are known. Therefore, by using equations (V.38) and (V.39), the new values for the marginal overflow parameters are found.

V.3.5.3. Termination of the Update Phase

To determine whether an optimum network based on the prespecified final link blocking probabilities is achieved or not, the results of two successive dimensioning iterations are compared. As Sheridan states, the comparison can be made in terms of the differences in the values of one of the following items from one iteration to another.

- i) Marginal capacity parameters
- ii) Marginal overflow parameters
- iii) Link dimensions
- iv) Total network cost

The stopping criterion employed in the computer program is based on the differences of the link capacities. However, the results of the test problems indicate that the above mentioned four checks turn out to be equivalent. When one of them is satisfied, the remaining three are also satisfied as can be seen by observing the results presented in section VI.1. When network stabilization is attained, the dimensioning iterations and thus the updating of the marginal parameters is terminated. The currently dimensioned network is optimal with respect to the prespecified final link blocking probabilities. When the algorithm converges, the outputs of this stage are the capacities, realized blocking probabilities of each link and the approximate total network cost.

V.3.6. CALCULATION OF GRADE OF SERVICE

Up to this stage, the end-to-end blocking probability constraints were not imposed to the model. Therefore, the algorithm as such does not guarantee the overall grade of service levels to be satisfied. The grade of service levels to be met for each traffic relation will be ensured by a further operation within the algorithm in the constraint set of the linear programming problem, which is discussed in section V.3.8. However, to see what the realized grade of service levels are under the current dimensioning scheme, they are calculated to supply additive information. This step can aid in giving an idea about the effect of approximations introduced to the model as a consequence of rounding-off to obtain integer trunk group sizes.

The realized grade of service levels can be calculated by either using Gaudreau's or Blaauw's method. Since the constraint set of the linear programming problem for finding each final link blocking probability depending on the grade of service level to be achieved is based on Blaauw's method, it was seen fit to choose Blaauw's method to calculate the realized grade of service levels although it introduces some extra approximations to the model.

Even though the theory and methodology of Blaauw's procedure can be found in Reference [3], it will be helpful to summarize the main points. The basic assumption made by Blaauw is that the final link blocking probabilities and the end-to-end blocking probabilities are small. First, Blaauw derives some approximate recursive relations to calculate the end-to-end blocking probabilities experienced by each traffic relation. Then he proves the validity of these relations. His proof is very appealing and is presented in the following lines only with small changes in his original notation in order to introduce the reasoning behind his method and the nature of the approximations he makes.

The following derivations are based on Figure V.5. devised by Blaauw [3].

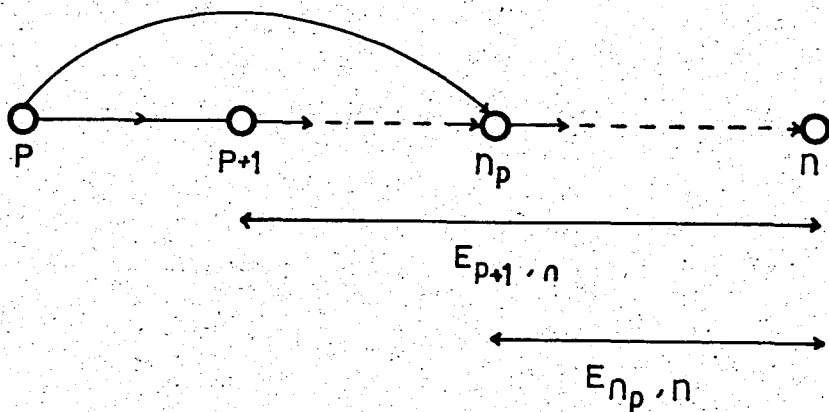

Figure V.5. Representation of the Paths Connecting Switching Center p to Switching Center n

The end-to-end blocking probability for the traffic relation (p, n) , represented by $E_{p, n}$, is desired to be calculated. Suppose that the link directly connecting nodes p and n_p is a high usage link and its blocking probability is indicated by \bar{b}_{p, n_p} . Obviously, if there exists no high usage link from node p to node n_p , the blocking probability is set equal to one. There are two ways to form a connection between node p and n . If on the high usage link from node p to n_p , there is a free trunk, then the connection will be formed via this trunk group and further through any path from node n_p to n supposing that n_p and n

are different nodes. The second way to form the connection between nodes p and n arises when the high usage link between p and n_p is completely occupied but the link from node p to $p+1$ has idle capacity. Then the connection is formed via the link between nodes p and $p+1$ and then further from $p+1$ to n over a certain route.

$$\begin{aligned}
 \text{Then, } 1-E_{p,n} &= p(\text{path from } p \text{ to } n \text{ exists}) \\
 &= p\{[(\text{free trunk on } p \text{ to } n_p \text{ exists}) \wedge \\
 &\quad (\text{path from } n_p \text{ to } n \text{ exists})] \vee \\
 &\quad [(\text{all trunks from } p \text{ to } n_p \text{ occupied}) \wedge \\
 &\quad (\text{free trunk on } p \text{ to } p+1 \text{ exists}) \wedge \\
 &\quad (\text{path from } p+1 \text{ to } n \text{ exists})]\}
 \end{aligned}$$

Substituting the appropriate blocking probabilities, equation (V.40) results.

$$1-E_{p,n} = (1-\bar{b}_{p,n_p})(1-E_{n_p,n}) + \bar{b}_{p,n_p}(1-b_{p,p+1})(1-E_{p+1,n}) \quad (\text{V.40})$$

Rewriting (V.40), equation (V.41) is obtained.

$$E_{p,n} = (1-\bar{b}_{p,n_p})E_{n_p,n} + \bar{b}_{p,n_p}(b_{p,p+1} + E_{p+1,n} - b_{p,p+1}E_{p+1,n}) \quad (\text{V.41})$$

Neglecting the product of $b_{p,p+1}$ by $E_{p+1,n}$, equation (V.42) follows directly from (V.41).

$$E_{p,n} \cong (1-\bar{b}_{p,n_p})E_{n_p,n} + \bar{b}_{p,n_p}(b_{p,p+1} + E_{p+1,n}) \quad (\text{V.42})$$

The value of $E_{p+1,n}$ is calculated through a similar reasoning and then substituted into (V.42) to obtain the numerical value of $E_{p,n}$. Equation (V.42) represents the recursive relations that Blaauw derived to calculate the end-to-end blocking probabilities. The omission of the product term is verified by the main assumption of Blaauw, implying that the product is small since each blocking probability is assumed to be small. Furthermore, the right-hand side of (V.41) is naturally smaller than the right-hand side

of (V.42) which shows that the end-to-end blocking probabilities, calculated by the usage of Blaauw's recursive relations, are higher than what they really are. Then, obviously the links are somewhat overdimensioned, but the small approximation error can be accepted as a safety factor.

Blaauw expresses that the end-to-end blocking probabilities can be written as linear functions of the final link blocking probabilities supposing that the blocking probabilities of the high usage links are known. As can be observed from equation (V.42), the coefficients of the linear functions are solely dependent on the high usage link blocking probabilities. Blaauw has employed some proven properties to derive an efficient way for the calculation of the coefficients, rather than using the mathematical recursive relations given in Reference [3] but not included in the thesis. The simple rule, devised for the case where the high usage links are not crossing each other, is stated as follows.

"Introduce in the scheme of links a cut through the hierarchical trunk group; the coefficient of the blocking probability of this hierarchical trunk group in the expression for the end-to-end blocking probability is equal to the product of the blocking probabilities of the high usage links which are cut."

This simple rule sets the basis for the method utilized in the thesis to calculate the end-to-end blocking probabilities for each traffic relation. To give more insight, the rule is applied to two examples in section C of the Appendix.

V.3.7. CALCULATION OF GRADIENTS

The dimensioning procedure and its outputs were based on the values of the prespecified final link blocking probabilities. Therefore, to terminate the algorithm, there has to be a check to decide if the final link blocking probabilities need to be changed. If such a change is not required, then the overall dimensioning procedure is terminated and an optimal dimensioning scheme has been achieved. However, if a change in the current values of the final link blocking probabilities is observed to be necessary, then the algorithm continues. Thus, in order to make the decision of stopping or continuing, an optimality

check is essential. To perform this optimality check, it is suggested in Reference [6] to determine the gradients of total network cost with respect to each final link blocking probability. The basic mathematical theory to approximately determine the values of the mentioned gradients, sketched in Reference [6], is to be presented hereby in a more detailed fashion.

To determine the gradients of total cost with respect to the final link blocking probabilities, the first assumption made is that the sizes of all high usage trunk groups are fixed. Since the fresh input traffic values are taken as data without subject to changes in the dimensioning procedure, this assumption is valid for direct links. However, the input traffic for second or higher overflow links is dependent on the blocking probabilities of the previous links. When such blocking probabilities are changed, as they are intended to, then the degenerate input traffic to the remaining high usage links is subject to some change. If there is a considerable change in the degenerate input traffic values, then the sizes of the high usage links can no longer be fixed. With the inclusion of this assumption, the global optimum is not guaranteed to be reached. Within the derivation of the gradients to obtain their numerical values, this assumption is implicitly used while in the redimensioning steps for the links, it is slackened.

The second assumption is that the variation in the amount of traffic flowing through the tandem switches produced by a variation in the final link blocking probabilities is insignificant enough to be considered as null. Even though this assumption also leads to an approximation, considering that the link blocking probabilities are small and vary within a tight interval while the amount of traffic flowing through such tandem switches is considerably high, the approximation error is tolerable.

Utilizing the aforementioned two basic assumptions and considering the cost function represented by expression (V.9), the gradients of total cost with respect to the final link blocking probabilities are given by equation (V.43) [6].

$$\frac{\partial C}{\partial b_k} = C_k \left(\frac{\partial N_k}{\partial b_k} \right) A_k \quad (V.43)$$

Following the definition of link blocking probability, the final link blocking probabilities can be expressed as in (V.44).

$$b_k = \frac{a_k}{A_k} \quad (V.44)$$

Substitution of (V.44) into (V.43) yields equation (V.45).

$$C_k \left(\frac{\partial N_k}{\partial b_k} \right)_{A_k} = C_k A_k \left(\frac{\partial N_k}{\partial a_k} \right)_{A_k} \quad (V.45)$$

But,

$$\left(\frac{\partial N_k}{\partial a_k} \right)_{A_k} = - \frac{1}{H_k}$$

Finally, the gradients of total network cost with respect to the final link blocking probabilities is obtained as in equation (V.46).

$$\frac{\partial C}{\partial b_k} = - C_k \frac{A_k}{H_k} \quad (V.46)$$

where,

H_k is the marginal occupancy of link k.

In equation (V.46), the numerical values of C_k and A_k are known. The value of H_k can be evaluated by using equation (V.19). Thus, by using equations (V.46) and (V.19) simultaneously, the gradients of total network cost with respect to final link blocking probabilities are evaluated numerically.

V.3.8. UPDATING THE FINAL LINK BLOCKING PROBABILITIES

Due to the interdependence between the final link blocking probabilities and link sizes, those blocking probabilities had been initialized at the beginning of the algorithm. At the first overall dimensioning iteration, having the grade of service criteria satisfied is not necessary because such constraints are included to the model within the linear programming problem, which will be introduced in the following paragraphs. At the end of the first overall

dimensioning iteration, the linear programming problem is strictly employed without being conditioned on any stopping criteria. Therefore, the assurance of the grade of service criteria are guaranteed in all of the overall dimensioning iterations following the initial one. In this aspect, the initial values of the final link blocking probabilities are not crucial. In the computer program, the initial final link blocking probability values are chosen in a way that the grade of service criterion is roughly ensured for each traffic relation.

After the first overall dimensioning iteration, the linear programming problem is used only if a change in the current values of the final link blocking probabilities is required. The objectives in implementing the linear programming problem to the dimensioning algorithm can be summed as follows. First, it is aimed to guarantee the grade of service criteria and then to find the optimal final link blocking probabilities to replace the current values while reiterating. The linear programming problem, which is originally introduced in Reference [6], is paraphrased and extended as follows.

$$\min. Z = \sum_{k \in F_k} \left(\frac{\partial C}{\partial b_k} \right) b_k \quad (V.47)$$

subject to,

$$E_j(b_k) \leq E_{\max} \quad \forall j \quad (V.48)$$

$$b_k \leq 1 \quad \forall k \quad (V.49)$$

$$b_k \geq 0.001 \quad \forall k \quad (V.50)$$

In the linear programming problem, the decision variables are the final link blocking probabilities, denoted by b_k . The coefficients of the decision variables in the objective function are the gradients that were discussed in the previous section. The numerical values of the gradients had been calculated so that they are available for use at this stage. It should be noted that the gradients are of negative magnitude. Thus, the new values for b_k will be as high as possible, and in general the constraints given by (V.48) will hold as equality.

Expression (V.48) represents the grade of service criteria to be satisfied for each traffic relation. The left-hand side of (V.48) is actually nonlinear. However, the nonlinear relationships are expressed as approximate linear relations due to Blaauw. Thus, to form the constraints given by (V.48), the concepts presented in section V.3.6 are utilized. It is not possible to use Gaudreau's formulae to represent the end-to-end blocking probabilities in the constraint set of the linear programming problem since Gaudreau's method of calculating end-to-end blocking probability requires the numerical values of each final link blocking probability. In Gaudreau's method the final link blocking probabilities can not be considered as decision variables of a linear programming problem; therefore, Blaauw's method is chosen. The following constraints represented by (V.49) merely express that blocking probability can not be greater than one. By equations (V.50), a lower bound is established for each final link blocking probability. Equating the final link blocking probability to zero is obviously not reasonable within the context of equation (V.1). As a lower bound, 0.001 was considered sufficient, meaning that on a final link out of every 1000 calls being processed only one call is lost. In a different study, if necessary, the value of the lower bound can be changed without incurring difficulty. Similarly, the value of E_{\max} , designating the percentage of tolerable failing connections and taken as equal to 0.01 in the thesis, can easily be changed since it is supplied as an input.

The solution of the linear programming problem yields the new final link blocking probabilities so that the grade of service criteria are satisfied. With the new final link blocking probabilities, the dimensioning iterations are initialized once more. At the end of the dimensioning iteration, the achieved grade of service values may not exactly equal 0.01 due to rounding-off approximations incurred within the dimensioning steps. However, the deviation may somewhat be controlled by comparing the realized final link blocking probabilities with the values provided from the linear programming problem. If the difference between the realized and required blocking probabilities of a certain link is greater than the tolerable deviation value of link blocking probability, which is taken as 0.005 in the thesis, then the size of that link is increased.

The linear programming problem is solved by a package program named MATPRO (A Mathematical Programming Package) which had been adapted by Dr.A. Gündüz

Ulusoy, Nur Kesen (Özmızrak), and Bünyat Balaban in December 1979 at the industrial engineering department of Boğaziçi University [33]. Naturally, the linear programming problem can be solved by any other LP package program. Then, the subroutines providing the connection between the dimensioning steps and the linear programming problem, which are presented in Appendix D and H, need to be adjusted.

V.3.9. TERMINATION OF THE OVERALL DIMENSIONING ITERATIONS

To stop the overall dimensioning iterations and therefore to terminate the algorithm, the gradients that were obtained in two successive stages are compared. The comparison is made in terms of two criteria. For the first check, the square of the gradients of total cost with respect to the final link blocking probabilities are summed, and then the square root is taken. Let this value be named as the overall gradient or total gradient factor. From one overall dimensioning iteration to the other, if overall gradient values differ by not more than 5 %, then the algorithm is terminated. 5 % is seen sufficient in this study, but this value can easily be changed if necessary. When the behavior of the overall gradient value is analyzed throughout the example problems, it is seen that at first it increases from one overall dimensioning iteration to the other then starts decreasing to be followed by an increase in its value after several iterations. It was observed that once the overall gradient increases from the decreased value, then the solutions obtained at the further iterations are not better than the previous ones. Therefore, to converge quicker and to prevent cycling which may arise, a second check is incorporated after the fifth overall dimensioning iteration is completed. From then onwards, if the overall gradient value of the current overall dimensioning iteration is greater than the value obtained in the previous iteration, then the algorithm is terminated.

The two checks, given in the previous paragraph, constitute the optimality checks cited in section V.3.7. It should be noted that the nature of the checks and the comparison values, like 5 % and fifth iteration, are really subjective and depend on some experience with the specific computations. Since the global optimum is not guaranteed by the algorithm and an approximate solution is sought, the important aspect is to obtain some decrease in cost, if possible, while arriving at a feasible solution. Passing the two checks successfully

implies that the final link blocking probabilities need not be changed anymore. The algorithm terminates with an approximately optimal dimensioning for all of the links.

V.3.10. IMPLEMENTATION OF THE ALGORITHM

To clarify the dimensioning procedure explained in the previous sections of Chapter V, two flowcharts are given in this section. The first flowchart, illustrated in Figure V.6, shows the major steps of the dimensioning algorithm in a closed form.

All the operations, denoted by 1 through 7 in Figure V.6, have been thoroughly explained within the thesis. Modules 1 and 2 are viewed in section V.3.1 while sections V.3.2 to V.3.5 concern module 3. Sections V.3.6 and V.3.7 contain the explanatory material for modules 4 and 5, respectively. Operation 7 is analyzed in section V.3.8 while the check denoted by 6 is discussed in section V.3.9. A very important point can be clarified through the flowchart of Figure V.6. There are two main iterations within the dimensioning algorithm which are discussed in the thesis. One of them, named dimensioning iteration, is the iteration scheme occurring within module 3. The overall dimensioning iteration is brought about by returning from module 7 to module 3, which is clearly seen in Figure V.6.

The dimensioning steps of module 3 are rather complex. The functioning of this module is represented by the flowchart given as Figure V.7.

The computer program for the dimensioning procedure, whose main steps have been presented through the flowcharts, is written in FORTRAN IV. The computer program for the example cases were run on a UNIVAC 1110 system. The description of the computer program, in terms of the subroutines and essential variable definitions, is presented in Appendix D. The listing of the computer program is in Appendix H. To delineate the structure of the computer program, Figure V.8. is included in this section.

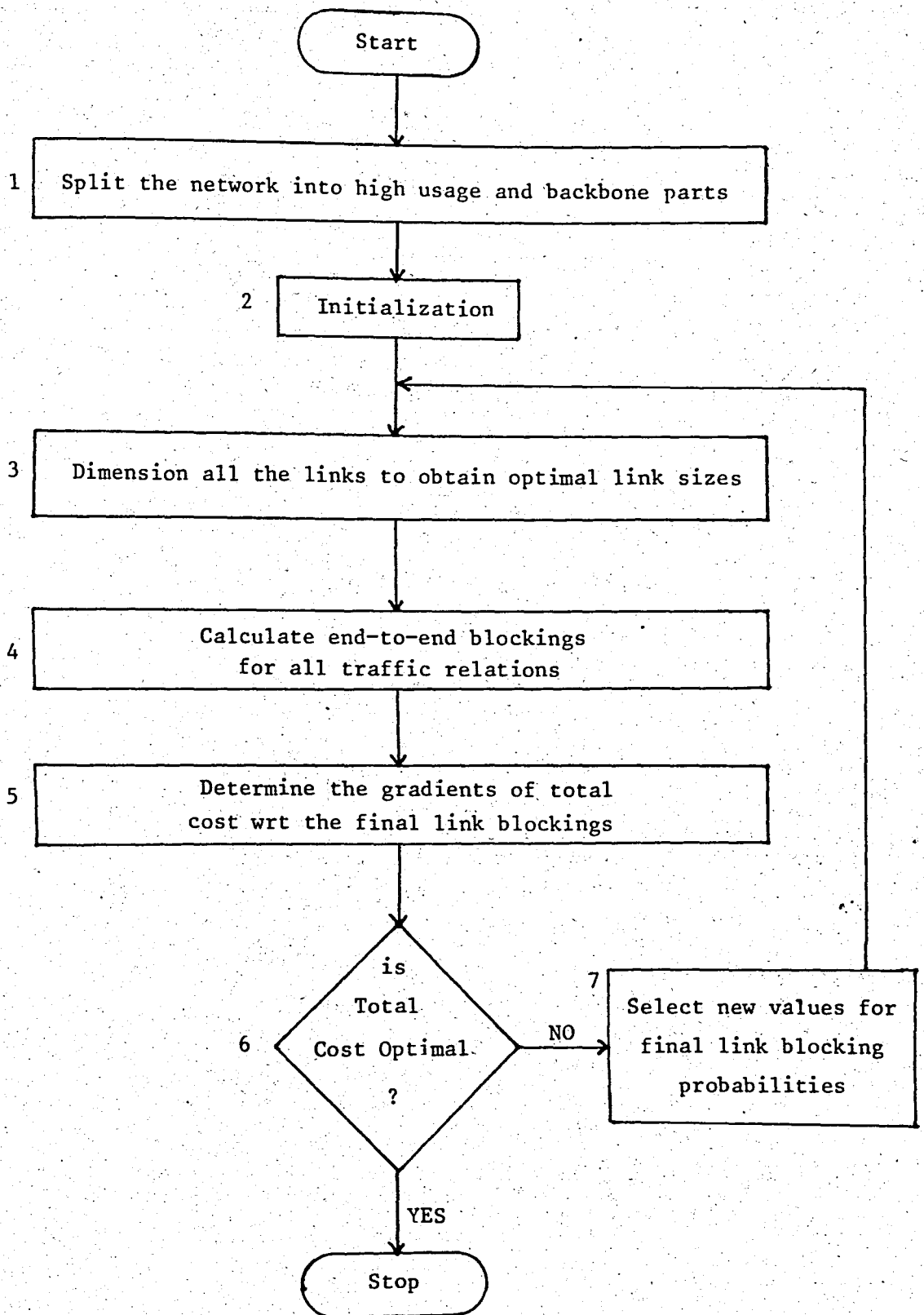
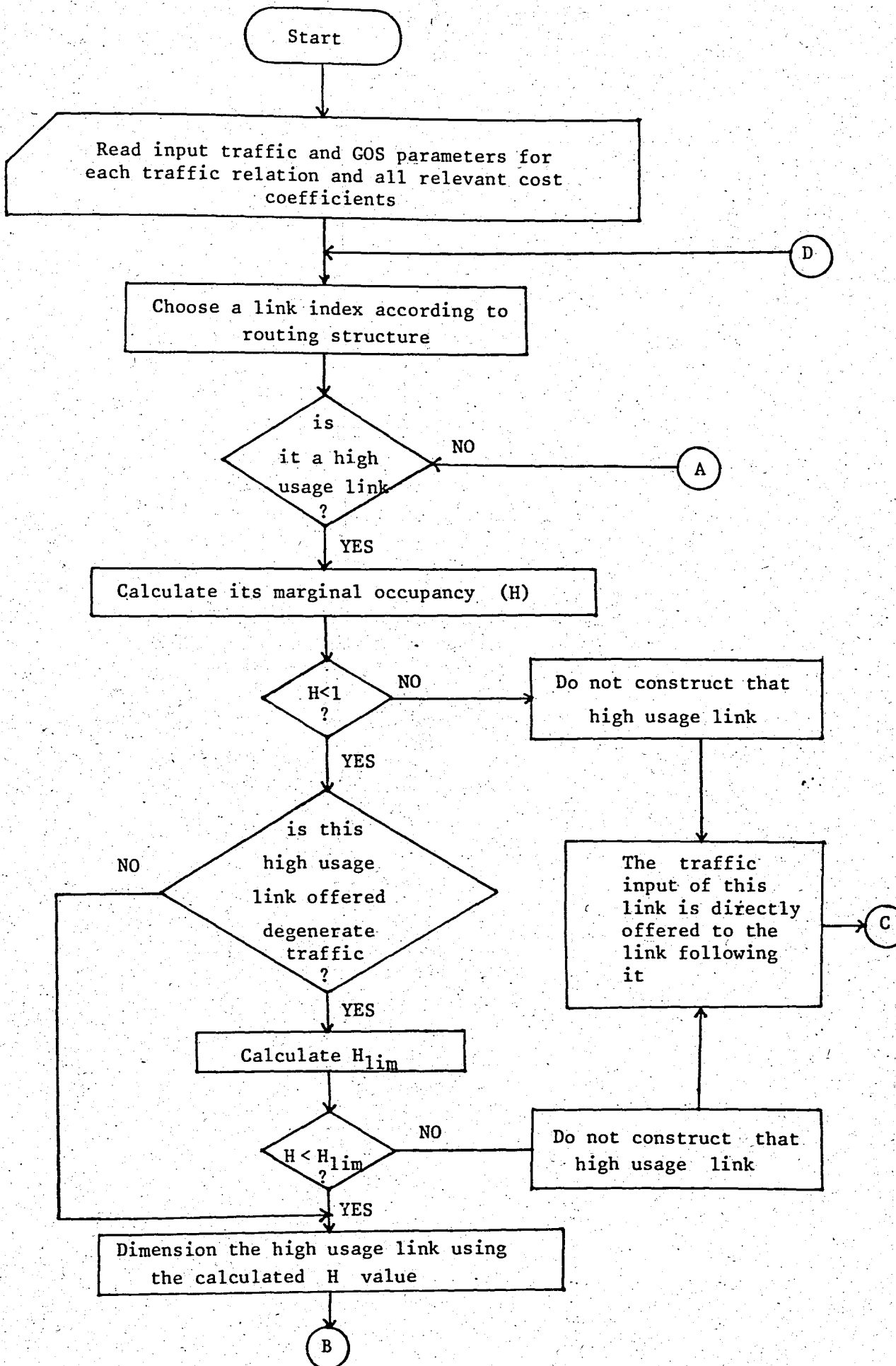
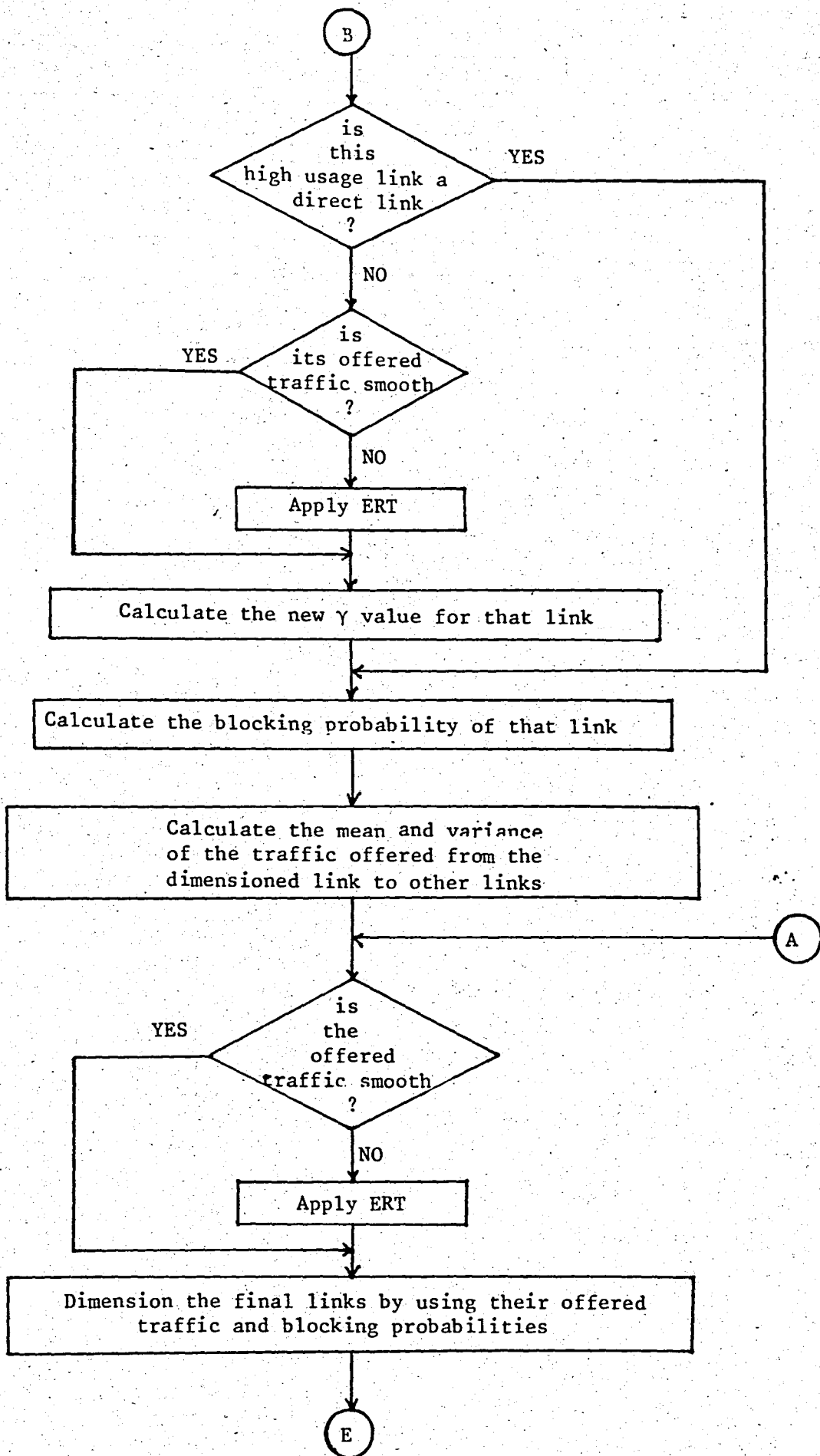

Figure V.6. Flowchart of the Solution Procedure





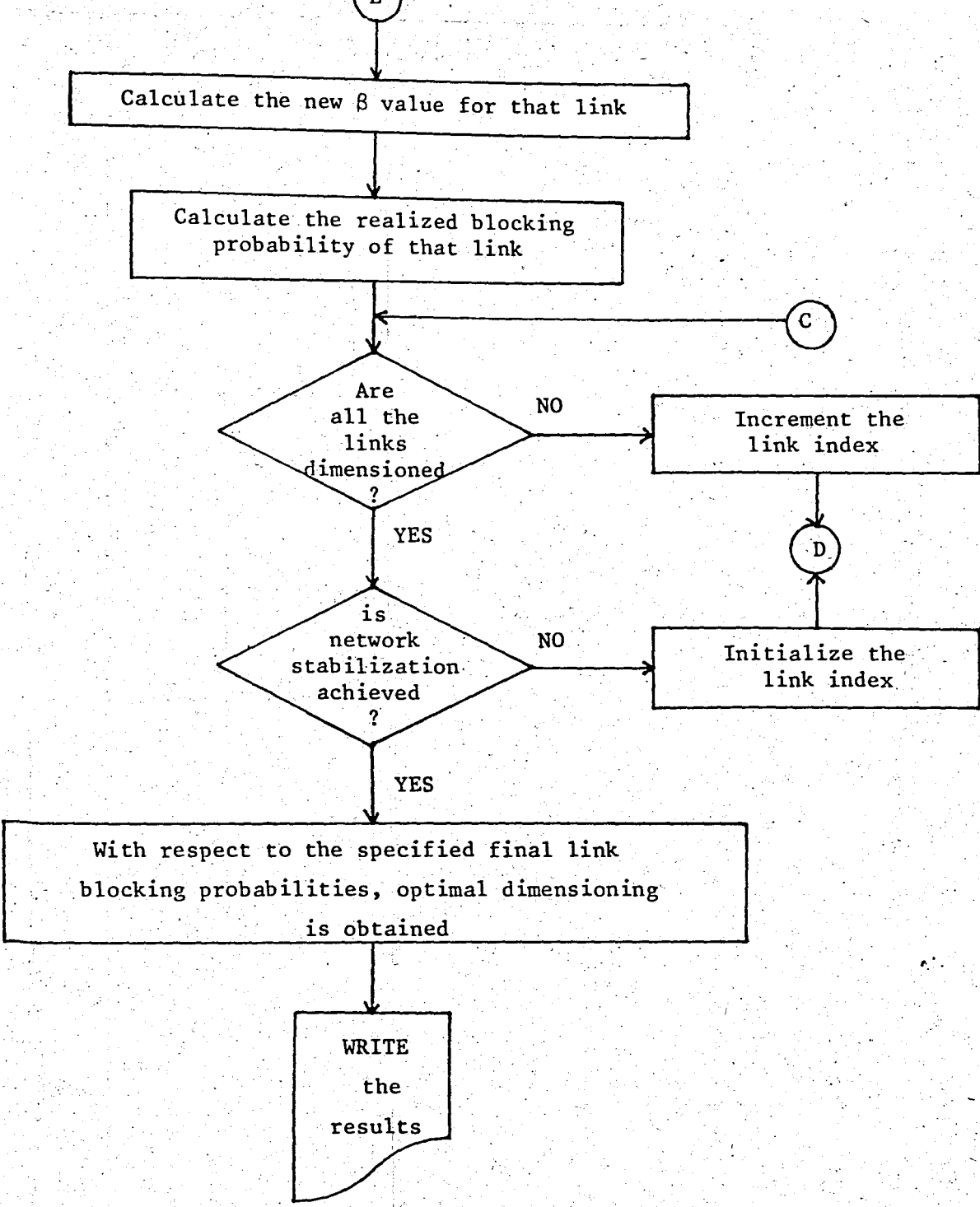
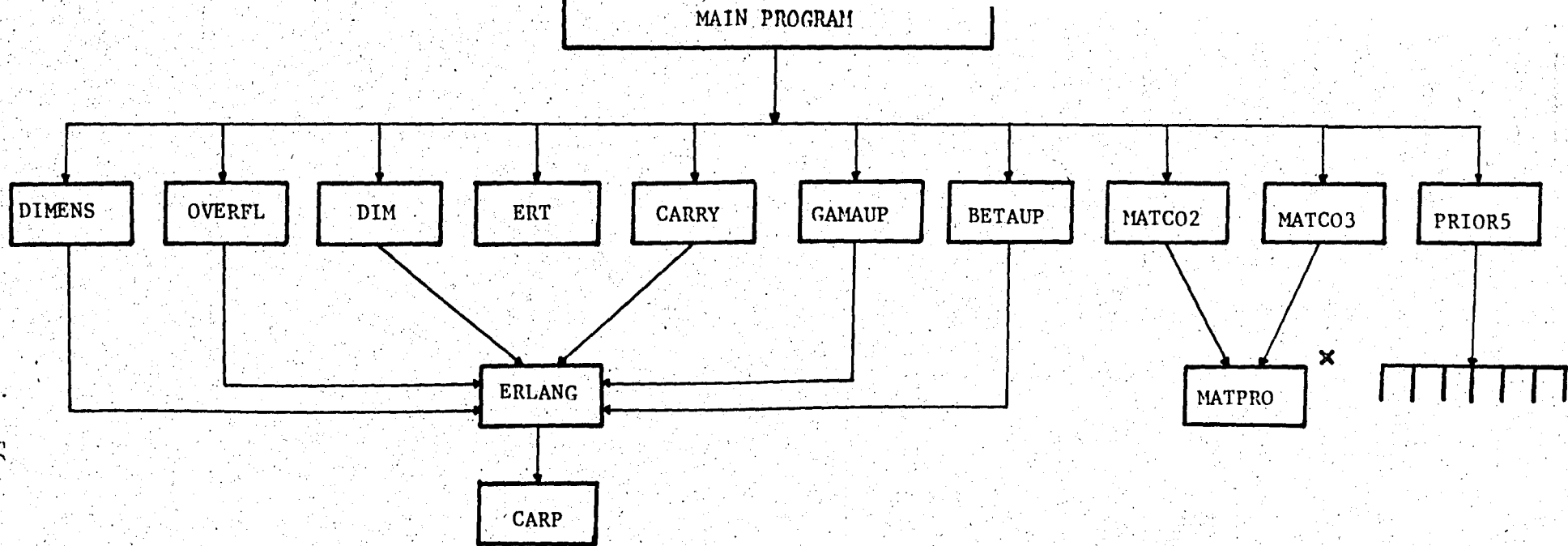

Figure V.7. Flowchart for the Dimensioning of the Links



96

Figure V.8. The Program Structure

* The names of the subroutines of the MATPRO package program which are utilized in the switching network optimization program are as follows:

LINP, LP, DOANLP, ADDCON, CHACC, CHBSIS, CHSLCK, COPY, DATA, FIRSTB, IEXIT, IPRINT, ISOPT, NEWVEC, REDUCE, REVERT, SEEKX, SEEKY, SPRINT.

** Subroutine PRIOR5 uses the subroutines DIMENS, OVERFL, DIM, ERT, CARRY, BETAUP, MATCO2, ERLANG, and CARP as shown for the main program.

CHAPTER VI

NUMERICAL RESULTS AND DISCUSSION

The dimensioning procedure presented in the previous chapters of the thesis is applied to some small sized example networks to obtain numerical results and to establish the functioning of the dimensioning algorithm. The dimensioning results will be tabulated in this section. The results concerning one example network are given in some detail to clarify the dimensioning steps and the usage of the variables appearing in the computer program.

1. EXAMPLE PROBLEM

As an example problem, the simple network illustrated in Figure VI.1 is considered.

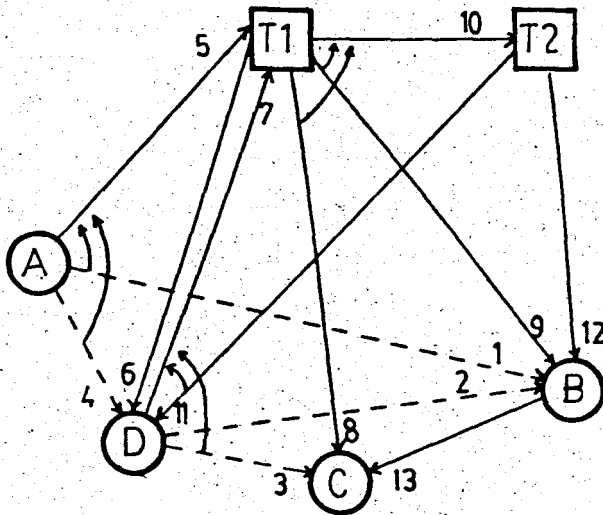

Figure VI.1. Example Network

The network of Figure VI.1 has two overflow possibilities for each calling pair; thus, the priority given by IPRI[†] is three. As can be observed from

† All of the variables used in this chapter are explained in Appendix D.

In the figure, there are four traffic relations given by (A,B), (D,B), (D,C), and (A,D) in terms of node specification. The four node pairs can equivalently be described by the four direct links connecting them. That is, instead of (A,B), (D,B), (D,C) and (A,D), (1), (2), (3), and (4) are used respectively considering simplicity in programming. Therefore, by traffic relation (1), the traffic flowing from switching center A to switching center B is indicated.

The values of the necessary input variables, matrices, and arrays which have been explained in Appendix D are given in the following lines.

Table VI.1. The Specification of IALT(j,r) for the Example Problem

j \ r	1	2
1	5	9
2	7	9
3	7	8
4	5	6

In Table VI.1, index j corresponds to traffic relations while r corresponds to the number of links forming the alternate route for that traffic relation. A single element of IALT(j,r) represents the link forming the r-th link of the alternate route for the j-th traffic relation.

Table VI.2. The Specification of IFIN(j,m) for the Example Problem

j \ m	1	2	3	4
1	5	10	12	0
2	7	10	12	0
3	7	10	12	13
4	5	10	11	0

A single element of IFIN(j,m) represents the link forming the m-th link of the final route for the j-th traffic relation. Zero entry for IFIN(j,m) means that there is no such further link since the connection between the traffic relation has already been supplied by the specified link numbers.

For the example network, the following equalities need to be made to specify the variables.

$$\begin{array}{lll} \text{NA} = 7 & \text{NAA} = 9 & \text{NALT} = 2 \\ \text{NF} = 13 & \text{NL} = 4 & \text{NT} = 4 \end{array}$$

The initial β values for the final links, denoted by 5,7,10,11,12 and 13 in the network, are set equal to 0.8 while the initial γ values for the second overflow links, denoted by 6,8 and 9 in the network, are equated to 0.5. As initial final link blocking probability values, 0.005 is assigned to the first link of each final route and 0.01 is taken for the remaining final links. That is, except for links 5 and 7 whose blocking probabilities are 0.005 initially, the blocking probabilities for all the other links represented by IFIN(j,m) are given as 0.01.

The values of input traffic, cost, and grade of service parameters are indicated as follows.

Table VI.3. The Specification of A(j) for the Example Problem

(erlangs)

Relation j	A(j)
1	2.00
2	3.00
3	4.00
4	0.75

An element of A(j) represents the forecasted or estimated traffic flow value for each traffic relation j.

Table VI.4. The Specification of $C(t)$ for the Example Network

Link t	$C(t)$
1	1500
2	1200
3	1000
4	1300
5	1700
6	1800
7	1900
8	2000
9	1750
10	1900
11	1850
12	1750
13	1100

(TL/trunk)

An element of $C(t)$ represents the cost of supplying one circuit on link t . The unit switching cost in the two tandem nodes are taken as:

$$CT_1 = CT_2 = 50 \text{ TL/erlang}$$

For each traffic relation j , the desired grade of service is 0.01. That is,

$$EEB = 0.01$$

With the inputs given in advance, the dimensioning steps are initiated. Some pertinent results of the three dimensioning iterations of the first overall dimensioning iteration are given as follows.

Table VI.5. The Value of the Marginal Occupancy Parameter (H)

Link t	Dimensioning Iterations		
	1	2	3
1	.33	.20	.23
2	.25	.16	.19
3	.18	.10	.12
4	.29	.13	.14
6	.38	.26	.26
8	.33	.25	.25
9	.38	.30	.29

Table VI.6. The Value of the Marginal Capacity Parameter (β)

Link t	Dimensioning Iterations		
	1	2	3
5	.500	.620	.620
7	.532	.772	.772
10	.580	.624	.624
11	.524	.500	.500
12	.690	.616	.616
13	.508	.504	.504

Table VI.7. The Value of the Marginal Occupancy Parameter (γ)

Link t	Dimensioning Iterations		
	1	2	3
6	1.000	1.000	1.000
8	.798	.746	.746
9	.669	.628	.628

Table VI.8. The Value of the Realized Link Blocking Probabilities

Link t	Dimensioning Iteration		
	1	2	3
1	.4000	.2105	.2105
2	.2061	.1101	.1101
3	.1172	.0628	.0628
4	.4286	.1385	.1385
5	.0027	.0058	.0058
6	1.000	1.0000	1.0000
7	.0048	.0129	.0129
8	.4130	.3473	.3473
9	.2279	.1992	.1992
10	.0128	.0254	.0254
11	.0075	.0110	.0110
12	.0199	.0061	.0061
13	.0063	.0115	.115

Table VI.9. The Real-Valued and Integer Valued Link Capacities at the First Overall Dimensioning Iteration

Link t	Dimensioning Iteration					
	1		2		3	
	X	N	X	N	X	N
1	2.30	2	3.23	3	3.00	3
2	4.30	4	5.18	5	4.84	5
3	6.40	6	7.48	7	7.21	7
4	0.68	1	1.66	2	1.59	2
5	5.60	6	3.99	4	3.99	4
6	0.14	0	0.21	0	0.20	0
7	5.75	6	4.33	4	4.33	4
8	2.30	2	2.40	2	2.45	2
9	4.96	5	5.26	5	5.30	5
10	7.60	8	6.33	6	6.33	6
11	4.89	5	4.11	4	4.11	4
12	8.48	8	7.65	8	7.65	8
13	4.82	5	4.16	4	4.16	4

Table VI.10. The Resulting Network Costs

Dimensioning Iteration	(TL)	
	TCOST1	TCOST2 [†]
1	93954	93980
2	88272	84943
3	87238	84943

At this stage, rather than proceeding with the tabulation of results, some relevant inferences will be included.

- i) By considering Table VI.5 and VI.9, it is observed that for a given input traffic as the marginal capacity parameter decreases in value the link size of that high usage link increases, as expected.
- ii) The first column of Table VI.6 and Table VI.7 show that at the end of the first dimensioning iteration, the β and γ values have changed from their initialized values of 0.8 and 0.5, respectively. The comparisons concerning the last two columns of Table VI.6 and VI.7 separately within themselves indicate that stability is achieved in terms of the marginal parameters.
- iii) Theoretically, the final link blocking probabilities displayed in Table VI.8 for links 5,7,10,11,12 and 13 should have been exactly equal to the initially specified input blocking probabilities. The difference between the realized and specified blocking probabilities stems from the rounding-off approximations. However, it is seen that the variation is not pronounced.
- iv) Table VI.9 gives the optimal link capacities under the specified final link blocking probabilities. The results of the second and third dimensioning iterations indicate that network stability is established.

[†] TCOST1 and TCOST2 are defined in Appendix D.

v) Table VI.10 shows the network costs effected by the dimensioning steps of the three iterations. The analysis of the last two rows indicates network stability as in the case of marginal parameters and link sizes.

It is to be noted that three iterations for convergence is rather quick. The network cost has been decreased by 9.6 % from 93980 TL to 84943 TL. However, the grade of service constraints have not been actively imposed while obtaining the above mentioned network costs. Changes in the values of the final link blocking probabilities have to be made to insure the grade of service levels and to possibly decrease the network cost from the current value of 84943 TL. The realized grade of service levels at the end of the third dimensioning iteration are calculated and listed in Table VI.11.

Table VI.11. The Realized Grade of Service Levels at the First Overall Dimensioning Iteration.

Relation t	GOS(j)
1	.003
2	.002
3	.002
4	.006

The realized grade of service levels for all traffic relations are less than 0.01, the target value. Thus, on the whole it is possible to increase the values of the final link blocking probabilities. Consequently, the link capacities and the total network cost are expected to decrease. To effect the changes linear programming is applied. The total gradient factor, which will be influential in terminating the overall dimensioning iterations, is 686463. The results of the LP problem are given by Table VI.12.

Table VI.12. The New Final Link Blocking Probabilities at the Second Overall Dimensioning Iteration

Link t	BLOK(t)
5	.0010
7	.0010
10	.0010
11	.0702
12	.2325
13	.2225

The final link blocking probabilities have changed considerably, as Table VI.12 displays, from the initially specified values. The overall dimensioning iteration being now equal to two, the links are redimensioned. The results of the second overall dimensioning iteration just prior to calling the LP problem are summarized in the following tables.

Table VI.13. The Real-Valued and Integer Valued Link Capacities at the Second Overall Dimensioning Iteration

Link t	X	N
1	3.00	3
2	4.84	5
3	7.21	7
4	1.59	2
5	5.31	5
6	0.20	0
7	5.99	6
8	2.48	2
9	5.34	5
10	8.92	9
11	2.85	3
12	3.73	4
13	1.88	2

Table VI.14. The Realized Grade of Service Levels at the Second Overall Dimensioning Iteration

Relation j	GOS(j)
1	.012
2	.006
3	.011
4	.008

At the end of the second overall dimensioning iteration, the total gradient factor increased from 686463 to 2513355 while TCOST1 and TCOST2 are computed to be 85994 TL and 85111 TL, respectively. Comparing Table VI.9 with Table VI.13, it is observed that at the second overall dimensioning iteration, the link capacities of links 5,7 and 10 have increased while the link sizes of 11,12 and 13 have decreased. This result is expected since the blocking probabilities of links 5,7 and 10 are decreased while the blocking probabilities of links 11,12 and 13 are increased as a consequence of the LP problem. The difference of the realized grade of service levels from 0.01 is due to rounding-off approximations. The observed differences are acceptable. The difference between the total gradient factors of the first and second overall dimensioning iterations is greater than 5%; therefore, the dimensioning steps are continued. The results of the LP problem and the third overall dimensioning iteration are presented in Table V.15, VI.16 and VI.17.

Table VI.15. The New Final Link Blocking Probabilities at the Third Overall Dimensioning Iteration

Link t	BLOK(t)
5	.0412
7	.0846
10	.0300
11	.0010
12	.0010
13	.1685

Table VI.16. The Real-Valued and Integer Valued Link Capacities at the Third Overall Dimensioning Iteration

Link t	X	N
1	3.00	3
2	4.84	5
3	7.21	7
4	1.59	2
5	2.09	2
6	0.16	0
7	0.88	1
8	1.79	2
9	4.61	5
10	4.58	5
11	5.29	5
12	8.49	8
13	1.89	2

Table VI.17. The Realized Grade of Service Levels at the Third Overall Dimensioning Iteration

Relation j	GOS(j)
1	.012
2	.013
3	.010
4	.010

At the end of the third overall dimensioning iteration, the total network costs TCOST1 and TCOST2 are decreased to 72620 TL and 73530 TL, respectively. The total gradient factor decreased from 2513355 to 1882231. The difference between the gradient factors is greater than 5%, so the dimensioning steps are continued possibly to achieve an improvement. The results of the LP problem and the fourth overall dimensioning iteration are delineated as follows.

Table VI.18. The New Final Link Blocking Probabilities at the Fourth Overall Dimensioning Iteration

Link t	BLOK(t)
5	.0010
7	.0444
10	.0010
11	.0702
12	.2704
13	.0950

Table VI.19. The Real-Valued and Integer Valued Link Capacities at the Fourth Overall Dimensioning Iteration

Link t	X	N
1	3.00	3
2	4.84	5
3	7.21	7
4	1.59	2
5	5.31	5
6	0.36	0
7	1.84	2
8	2.23	2
9	5.33	5
10	8.29	8
11	2.87	3
12	3.01	3
13	2.17	2

Table VI.20. The Realized Grade of Service Levels at the Fourth Overall Dimensioning Iteration

Relation j	GOS(j)
1	.016
2	.015
3	.014
4	.008

ie total network costs resulting at the fourth overall dimensioning iteration
:e 75742 TL and 73829 TL. The total gradient factor is calculated to be
701361. At the fifth dimensioning iteration, the gradient becomes 5278569.
nen, according to the stopping criteria explained in section V.3.9, the
imensioning iterations are terminated.

shortcoming of the dimensioning algorithm is indicated by the results. At
ach overall dimensioning iteration, the final link blocking probabilities
re calculated so as to impose a decrease in total network cost. However, due
o the rounding-off and theoretical approximations inherent in the algorithm,
decrease in total cost may not be realized as can be deduced by the results
of the third and fourth overall dimensioning iterations. In the third overall
dimensioning iteration, TCOST2 is 73530 TL while in the fourth iteration it is
73829 TL. However, the difference is not very significant. Rather than accepting
the results of the last overall dimensioning iteration as the optimal results,
it would be better to analyze all the results of the overall dimensioning
iterations. If the total cost of one case is significantly lower than those of
others, then the results of that iteration are considered to be optimal. If
the total costs are approximately equal for some iterations, then it is advis-
able to compare the realized grade of service levels and make the choice ac-
cordingly. In terms of the grade of service levels, the results of the third
overall dimensioning iteration are superior to those of the fourth and fifth
iterations. Therefore, for the example problem the results of the third overall
dimensioning iteration are optimal with optimal network cost equaling 73530 TL.
By the implementation of the LP problem within the dimensioning iterations,
the grade of service constraints are guaranteed. Furthermore, in the example
problem the network cost improved by 13.4% from 84943 TL to 73530 TL. When
the overall dimensioning steps are considered, 21.8% of an improvement is
induced by the procedure from the initial network cost of 93980 TL.

VI.2. RESULTS OF THE EXAMPLE PROBLEM FOR DIFFERENT CASES

The input parameters are the same as those for the example problem discussed
in section VI.1. First, the case in which priority equals one is considered.
Since this network structure consists of solely direct links between the
traffic relations, there is only one dimensioning iteration. The blocking prob-
abilities of the four links are set equal to 0.01 and accordingly dimensioned.

resulting link sizes are 7,8,10 and 4 trunks for links 1,2,3 and 4 respectively. Under this dimensioning scheme, the total network cost is 35300. Total network cost is significantly lower than the cost obtained for the example problem in which priority is equal to three. However, the two cases are not really comparable in terms of cost since the network of the example problem is structurally more reliable than the network corresponding to priority one.

The example network which corresponds to priority two is illustrated in Appendix E. For this case, only the initial and final results will be given for comparison purposes.

Table VI.21. Results of the First Overall Dimensioning Iteration for Priority 2 of the Example Network

Link t	$BLK(t)^{\dagger}$	X	N
1	.2105	2.85	3
2	.1101	4.70	5
3	.0627	6.62	7
4	.4286	1.18	1
5	.0046	4.54	5
6	.0117	4.17	4
7	.0129	4.33	4
8	.0060	5.74	6
9	.0058	8.56	9

TCOST1 = 68311 TL.

TCOST2 = 70152 TL.

$BLK(t)$ are the realized link blocking probabilities.

Table VI.22. The Realized Grade of Service Levels at the First Overall Dimensioning Iteration for Priority 2 of the Example Network

Relation j	GOS(j)
1	.002
2	.002
3	.001
4	.007

Table VI.23. Optimal Results for Priority 2 of the Example Network

Link t	BLK(t)	X	N
1	.2105	2.85	3
2	.1101	4.70	5
3	.0627	6.62	7
4	.4286	1.18	1
5	.0012	5.81	6
6	.0118	3.74	4
7	.0018	5.99	6
8	.1875	3.07	3
9	.0377	6.79	7

The optimal network costs are given by TCOST1 and TCOST2.

$$\text{TCOST1} = 64381 \text{ TL.}$$

$$\text{TCOST2} = 66154 \text{ TL.}$$

The number of the overall dimensioning iterations for convergence is 3.

Table VI.24. The Grade of Service Levels for Priority 2 of the Example Network at Optimality

Relation j	GOS(j)
1	.008
2	.004
3	.012
4	.006

The grade of service constraints are approximately satisfied by the optimal dimensioning scheme as Table VI.24 illustrates. The network cost is higher than the one obtained under priority one but lower than the cost obtained under priority three, as expected. The network structure corresponding to the second priority is less reliable than the structure implied by the third priority. The initial network cost has been improved by 5.7%.

The initial and final results corresponding to fourth priority are specified by the following four tables.

Table VI.25. Results of the First Overall Dimensioning Iteration for Priority 4 of the Example Network

Link t	BLK(t)	X	N
1	.2105	3.06	3
2	.2061	4.04	4
3	.1991	4.99	5
4	.1385	2.40	2
5	.0504	2.39	2
6	.0580	2.40	2
7	.0192	5.32	5
8	.0160	7.24	7
9	.0111	9.07	9

TCOST1 = 66764 TL.

TCOST2 = 63503 TL.

Table VI.26. The Realized Grade of Service Levels at the First Overall Dimensioning Iteration for Priority 4 of the Example Network

Relation j	GOS(j)
1	.013
2	.006
3	.007
4	.015

Table VI.27. Optimal Results for Priority 4 of the Example Network

Link t	BLK(t)	X	N
1	.2105	3.06	3
2	.2061	4.04	4
3	.1991	4.99	5
4	.1385	2.40	2
5	.0504	2.39	2
6	.0580	2.38	2
7	.0721	3.33	3
8	.0126	7.46	7
9	.0035	10.43	10

TCOST1 = 65744 TL.

TCOST2 = 61440 TL.

Table VI.28. The Grade of Service Levels for Priority 4 of the Example Network at Optimality

Relation j	GOS(j)
1	.011
2	.016
3	.017
4	.015

results relating to the case of priority five are not listed in this section. Since by resembling previous results, they do not lead to new points of discussion. It will be more meaningful to tabulate the priority five results in the following section for the bigger test network. After performing the dimensioning steps for the case with priority five, the resulting example network cost is 79055 TL which is less than the network cost of priority three by 9% and more than the cost of priority two by 16.3%. This result can be verified by the observation that in terms of network structure, the network priority five is more reliable than that of priority two but less reliable than that of priority three.

3.3. RESULTS OF THE TEST NETWORK

The test network is somewhat bigger than the example network, but still it is not in the vicinity of an actual switching network of a moderately large city or region. For example, the network of Istanbul contains 30 switching centers and 3 tandem switches. The aim of considering a relatively small test network is to have computational ease. At this stage, the emphasis is on demonstrating and verifying the functioning of the dimensioning procedure. The test network may supply a comparison yardstick for further future studies.

The description of the test network and the necessary input values are given in Appendix F. The grade of service levels will be tabulated in this section while the link capacities and the blocking probabilities are listed in Appendix G. The following table relate to priority three case.

At the first overall dimensioning iteration, except for traffic relation 11, the realized grade of service levels are less than 0.01, implying that some final link blocking probabilities can be increased so that network cost can decrease. The network cost is 227930 TL at the first overall dimensioning iteration and 216201 TL at optimality. Thus, 5.1% of improvement has been realized by the utilization of the LP problem. For convergence, 3 dimensioning iterations and 2 overall dimensioning iterations are made with the CPU time being 44.602 seconds.

For priority two case, the following grade of service levels are realized.

Table VI.29. The Realized Grade Of Service Levels For Priority 3 of the Test Network

Relation j	GOS(j)	
	First Overall Dimensioning Iteration	Optimal Iteration
1	.001	.003
2	.009	.012
3	.003	.002
4	.001	.000
5	.007	.012
6	.004	.010
7	.003	.007
8	.001	.002
9	.002	.010
10	.006	.012
11	.017	.013
12	.005	.014
13	.009	.004

Table VI.30. The Realized Grade of Service Levels For Priority 2 of The Test Network

Relation j	GOS(j)	
	First Overall Dimensioning Iteration	Optimal Iteration
1	.013	.009
2	.015	.015
3	.003	.003
4	.012	.008
5	.017	.016
6	.010	.013
7	.007	.012
8	.001	.001
9	.002	.010
10	.013	.014
11	.015	.012
12	.016	.015
13	.015	.011

Total cost decreased from 193761 TL to 189246 TL. The network cost is less than that obtained for priority three case, as expected. 2 dimensioning iterations and 4 overall dimensioning iterations have been necessary. In this case, the CPU time is 1 minute and 4.480 seconds. Even though there are less number of links than in the previous case, the CPU time has increased. This result can be justified by noting that in this case the LP is called two times more than in the previous case.

Table VI.31. The Realized Grade of Service Levels for Priority 4 of the Test Network

Relation j	GOS(j)	
	First Overall Dimensioning Iteration	Optimal Iteration
1	.003	.007
2	.002	.003
3	.004	.001
4	.004	.004
5	.003	.010
6	.005	.007
7	.002	.007
8	.005	.008
9	.004	.010
10	.021	.012
11	.017	.010
12	.023	.010
13	.023	.016

In the case of priority four, the total cost decreased from 212517 TL to 207898 TL. The network cost of priority four is less than that of priority three, but it is greater than the cost corresponding to priority two case. The network cost of this case is 9.0% worse than the cost of priority two. In the example problem, the difference between priority two and four was not marked, but in the test network the necessity and advantage of the optimization of the high usage links are clearly indicated. Thus, it can be observed that the dimensioning procedure is effective in guaranteeing the grade of service.

levels within approximation errors and improving the network cost. 4 overall dimensioning iterations are carried out with the CPU time being 52.423 seconds. The decrease in CPU time as compared with priority two case is attributed to the omission of high usage link optimization steps.

For the problem corresponding to priority five, Table VI.32 is prepared. In 43.969 seconds of CPU time, 3 dimensioning iterations and 2 overall dimensioning iterations are performed. The resulting network cost is 202175 TL.

Table VI.32. The Realized Grade of Service Levels for Priority 5 of the Test Network

Relation j	(GOS(j))	
	First Overall Dimensioning Iteration	Optimal Iteration
1	.013	.006
2	.034	.009
3	.006	.002
4	.008	.005
5	.013	.012
6	.010	.009
7	.007	.006
8	.004	.002
9	.003	.009
10	.027	.015
11	.034	.010
12	.034	.016
13	.030	.015

Due to the lack of a clearly defined testing network used by researchers to demonstrate the existing dimensioning algorithms for switching network optimization problem, the dimensioning procedure developed and presented in the thesis could not be compared and validated accordingly. Through the examples and results, it was aimed to clarify the functioning of the dimensioning procedure. The small example problems indicate that the

procedure is rapid in terms of the number of dimensioning iterations to achieve convergence. It should be remembered that the optimal results are approximate since there are theoretical approximations and rounding-off errors within the dimensioning methodology.

A further point requiring explanation is the deviation of the realized grade of service values from the target value of 0.01. Observing the tables given in this section, it can be seen that the values of the grade of service levels at optimality are in some cases less than 0.01 while in the others higher than 0.01, with the highest level being 0.017. The deviation is due to rounding-off approximations made for the final links. Horn [13] states that providing certain (neighbouring) traffic relations with better connection probability than other (dispersed) pairs is to be expected. In [13] it is proposed that the connection probability objective should be stated as a distribution. That is, citing from Horn:

"50% of the traffic demand should experience better than X% congestion, 90% should receive better than Y%, and 95% should receive better than Z% congestion."

The connection probability objective suggested by Horn is more flexible than considering just a certain target value and seems more appropriate for real systems. Furthermore, under such a connection probability objective, the realized grade of service values, given by the dimensioning procedure of the present study, do not pose connection problems.

CHAPTER VII

EXTENSIONS FOR FUTURE STUDY

It can be observed that the dimensioning procedure developed in the thesis meets its design objectives; however, by an extended algorithm, it may be possible to further reduce the network cost. A more efficient algorithm which also portrays real cases more closely may be devised. To obtain such an algorithm, some of the assumptions underlying the present model need to be relaxed. Accordingly, some extensions for future study are discussed in the following paragraphs.

It is obvious that the number of tandem switches to be utilized within the switching network and their respective locations are crucial decisions. If the number and location of the tandem switches are not carefully determined, then the investment value will unnecessarily increase and the system will function inefficiently. In the dimensioning procedure of the thesis, the number and location of the tandem switches are taken as input. Therefore, prior to using the dimensioning procedure, a separate optimization phase is needed to supply this structural information by considering service supplied besides fixed and variable investment costs. For the initial optimization phase of locational decisions, a multicriteria approach may be utilized. The problem can be defined as selecting a subset of P sites at which to establish tandem switches in order to serve the exchange switches located at Q distinct points, under single or multicriteria considerations. For the solution of this problem, Reference [29] may be used as a starting point.

By analyzing the dimensioning procedure explained in the previous chapters, it can be noted that the traffic between an exchange switch and a tandem switch consists of traffic destined for a switch, different from the tandem switch. That is, it is assumed by definition that no traffic originates or terminates at a tandem switch. If tandem switches are also considered as traffic exchange points besides switching traffic to other switches, then the dimensioning algorithm of the thesis would not be exactly applicable. In that case, a link

connecting an exchange and tandem switch would be viewed as both a final and a high usage link. However, the dimensioning method is based on economic criteria for high usage links and blocking considerations for final links. These two considerations can not be made simultaneously in the current dimensioning procedure. Blocking considerations need to follow the economic considerations. If a link is functioning both as a high usage and a final choice link, then a solution approach may be obtained by separating that single link into a high usage and a final choice part and then continuing with the dimensioning accordingly. However, more effective approaches to handle such problems may exist.

In the thesis, to calculate the blocking probability of rough traffic, the equivalent random theory was applied prior to using the Erlang-B formula. As an alternative, the simple method for approximating the blocking of rough traffic due to Fredericks [30] can be employed. Under this technique, the Erlang-B formula in the case of rough input traffic is given as $B(N/vmr, A/vmr)$. If this form of the Erlang-B formula is used, then the calculation of A^* and N^* , necessitated by the equivalent random theory, is not performed. Some examples are given in Reference [30], showing computational time for the equivalent random theory approach and Fredericks' technique. The CPU time for Fredericks' technique is comparably less than that required for the equivalent random theory. However, it should be remembered that Fredericks' technique is more approximate than the equivalent random theory approach. The variation in the results of the two methods as given in Reference [30] is not very pronounced. Therefore, after some more research on the variation of the results for different cases than those three given in [30] and accepting to lose somewhat from accuracy, Fredericks' method may be more appropriate for large networks where computational gain is significant.

In the thesis, smooth traffic is assumed to be approximated by Poisson distribution. In Reference [30], it is expressed that for smooth traffic, there are Fredericks', Bretschneider's, Delbrouck's, and Hayward's approximating methods. However, an algorithm that operates satisfactorily has not been established yet. It is indicated that further research on the subject is required.

The specification of some threshold values for the switching network entities may be necessary after considering the actual network. For example, it may be

demanding that certain link sizes should be greater than some number. Such constraints can be readily incorporated to the dimensioning algorithm in the form of checks. In some cases, if input traffic is relatively small, it may be demanded that direct links should not be provided. The dimensioning algorithm and its computer program is constructed to handle such cases. Therefore, it is only necessary to place such threshold requirements. As a further study, the threshold values may perhaps be generated automatically within the algorithm.

An important shortcoming of the dimensioning procedure developed in the thesis is that it does not account for modularity. Modular trunking is becoming common with the introduction of digital switches and transmission facilities. Under modularity, fewer but larger trunk groups are to be resulted [13]. Modularity considerations can be incorporated to the dimensioning method by rounding-up and rounding-down the number of circuits obtained, considering the module size. If module size is supposed to be one under such a scheme, then the dimensioning procedure of the thesis results. However, a more refined approach, encompassing modularity in dimensioning, can be developed in further studies. Whether modularization will be introduced within the dimensioning steps or after the dimensioning algorithm converges is an important subject to be analyzed.

The dimensioning procedure explained in the thesis is a single-hour method based on the concept of economic load on the last trunk (ECCS). The network is designed to carry only a single hour's load. However, in practice the load on the high usage and final links varies from hour to hour. The question arising in single-hour engineering is which of the hours of loads should be used to engineer the group. It would be uneconomical to dimension a high usage link for its individual group busy hour if this hour does not coincide with the busy hour of the alternate routes. If the hours of peak traffic loads between various pairs of switching centers coincide, there is no such problem and dimensioning can be made on the basis of the single busy hour. However, for the switching centers in residence and business areas, the hours corresponding to peak traffic loads would be different, implying a problematic case for the application of single-hour engineering methods. Then, it would be advisable to dimension the network for more than one hour of end-to-end traffic data by using multihour engineering. Although, in References [8] and [9] multihour engineering procedures, whereby a least cost traffic network is engineered for more than one set of end-to-end loads being subject to the constraints that

blocking on any final choice trunk group should not exceed a specified value, are described some aspects of the procedure still need clarification through research. The problematic aspects of multihour engineering are summarized in Chapter III, and how to incorporate end-to-end grade of service criteria to the procedure is not really clear. However, further research may resolve such problems. Then, by using multihour engineering to dimension switching networks, additional decrease in total network cost can be achieved.

The optimization of switching networks should really be dynamic like other investment planning problems. Telephone networks are continually expanding and also new equipment is being introduced to the system. Such a situation raises the important issue of designing networks which are optimal over a period of time. The investment planning problem of the networks should really be thought in terms of middle and long range. The decision concerning how the target network will be reached in the course of years is very important. However, due to the size of the problem and the nonlinear characteristics, switching networks are modeled as being static. A time-phased approach is not used in the thesis. If in a future study, a time-phased switching network optimization is solved, the results would be more realistic and applicable.

The dimensioning procedure developed in the thesis may be accepted as a preliminary study. More exact algorithms with more desirable characteristics may be developed through further research even though the present dimensioning procedure has additional advantages over the other existing methods, as given in Chapter IV. The dimensioning method of the thesis has to be compared with existing or future methods to completely evaluate and rank it.

CHAPTER VIII

CONCLUSION

A dimensioning procedure is developed to aid in the investment planning of switching networks. The theoretical reasoning given throughout the thesis and the numerical results of the special applications indicate that the grade of service constraints aimed to be provided for the subscribers are satisfied and the network cost is optimized within acceptable approximation errors. The method is developed by making use of the appropriate portions of some currently available methods. Basically, for the dimensioning of high usage links Pratt's method [26], [31] is used while for the dimensioning of final links, Wilkinson's [34] formulae and equivalent random theory are utilized. Especially in the updating phase of the marginal parameters, Sheridan's [31] arguments have been applied. Blaauw's [3] linear expressions have been employed to calculate the grade of service levels. The incorporation of a linear programming problem to the heuristic dimensioning procedure, originally suggested by a group currently working on Cost 201 (European Co-operation in Scientific and Technical Research) project [6], has been specially rewarding.

By the dimensioning procedure, a hierarchical switching network with probabilistic input traffic is optimized. The dimensioning procedure is a single-hour engineering method which is based on economical considerations. Modularity and time-phased aspects of the investment problem have not been incorporated to the dimensioning algorithm.

The contributions of the dimensioning procedure developed in the thesis can be summed under two basic points. Rather than guaranteeing just the final link blocking probabilities as in Pratt's original method, this dimensioning procedure guarantees the end-to-end blocking probabilities to be within a desirable limit. Besides, within the theoretical framework of the dimensioning algorithm, a restriction on the number of allowable overflow possibilities is not imposed. Even though these are considerable improvements, a more refined algorithm may be devised by also considering the extensions introduced in the previous chapter.

BIBLIOGRAPHY

1. Berry, L.T.M., "An Application of Mathematical Programming to Alternate Routing", Australian Telecommunication Research, Vol.4, No.2, 1970, pp. 20-27.
2. ———, "A Mathematical Model for Optimizing Telephone Networks", Thesis for Ph.D. (Adelaide), December 1971.
3. Blaauw, A.K., "End-to-End Blocking Probability Between Two Exchanges", Unpublished Technical Note, 1980.
4. ———, "Optimal Design of Hierarchical Networks with Alternate Routing Based on an Overall Grade of Service Criterion", Network, Proceedings of 80 Paris Conference, 1980, pp. 116-123.
5. Chan, W.S., "Recursive Algorithms for Computing End-to-End Blocking in a Network with Arbitrary Routing Plan", IEEE Transactions on Communications, Vol. 28, No.2, 1980, pp. 153-164.
6. Cost Project 201, "Methods for Planning & Optimisation of Telecommunications Networks", Annual Progress Report 1980/81.
7. Deschamps, P.J., "Analytic Approximation of Blocking Probabilities in Circuit Switched Communication Networks", IEEE Transactions on Communications, Vol.27, No.3, 1979, pp.603-606.
8. Eisenberg, M., "Engineering Traffic Networks For More Than One Busy Hour", Bell System Technical Journal, Vol.56, No.1, 1977, pp. 1-19.
9. Elsner, W.B., "A Descent Algorithm for the Multihour Sizing of Traffic Networks", Bell System Technical Journal, Vol.56, No.8, 1977, pp.1405-1430.

10. Evranuz, Ç., Ç. Mısırlı, A.T. Dalgıç, T. Menlioğlu, "Telekomünikasyon Şebekelerinin Planlanması", A Paper Presented At The Seventh National Operations Research Congress, Istanbul, September 1981, pp. 1-10.
11. Gaudreau, M.D., "Recursive Formulas for the Calculation of Point-to-Point Congestion", IEEE Transactions on Communications, Vol. 28, No.3, 1980, pp. 313-316.
12. Harris, R.J., "Concepts of Optimality in Alternate Routing Networks", Thesis for Ph.D. (Adelaide), January 1974.
13. Horn, R.W., "End-to-End Connection Probability-The Next Major Engineering Issue?", 9th ITC Torremolinos 1979, pp. HORN-1-HORN-8.
14. Kalaba, R.E., M.L. Juncosa, "Optimal Design and Utilization of Communication Networks", Management Science, Vol.3, No.1, 1956, pp. 33-44.
15. Katz, S., "Statistical Performance Analysis of a Switched Communications Network", 5th International Teletraffic Congress, 1967.
16. Kortanek, K.O., Lee. D.N., Polak. G.G., "A Linear Programming Model for Design of Communications Networks with Time Varying Probabilistic Demands", Naval Research Logistics Quarterly, Vol.28, No.1, 1981, pp. 1-32.
17. Messerli, E.J., "Proof of a Convexity Property of the Erlang B formula", Bell System Technical Journal, Vol.51, 1972, pp. 951-953.
18. Mısırlı, Ç., Ç. Evranuz, "Santral Şebekelerinin Optimizasyonu ve Çözüm için Yaklaşık bir Algoritma", A Paper Presented At The Seventh National Operations Research Congress, Istanbul, September, 1981.
19. Mina, R.R., "The Theory And Reality Of Teletraffic Engineering", Part 1 of A Series On Telephone Traffic Engineering, April 1971, pp. 32-37.
20. ———, "A Review of Elementary Traffic Theory", Part 2 Of A Series On Telephone Traffic Engineering, June 1971, pp.32-37.

21. ———, "The Mathematics of Telephone Traffic Distribution", Part 4 of A Series On Telephone Traffic Engineering, September 1971, pp. 26-33.
22. ———, "Understanding The Erlang B Formula", Part 5 of A Series On Telephone Traffic Engineering, September 1971, pp. 72-82.
23. ———, "Improved Loss Formulas for Smooth and Rough Traffic", Part 6 of A Series On Telephone Traffic Engineering, January 1972, pp. 26-29.
24. ———, "Calculating Congestion in Link Systems", Part 10 of A Series On Telephone Traffic Engineering, May 1973, pp. 33-38.
25. Pearce, J.G., Telecommunications Switching, Plenum Press, New York, 1981.
26. Pratt, C.W., "The Concept of Marginal Overflow in Alternate Routing", 5th ITC New York 1967, pp. 51-58.
27. Rapp, Y.A., "Planning of Junction Networks with Non-Coincident Busy-Hours", Ericsson Technics, Vol. 27, 1971, pp. 3-23.
28. Rosen, J.B., "The Gradient Projection Method for Nonlinear Programming. Part 1. Linear Constraints", J.Soc. Indust. Appl. Math., Vol. 8, 1960, pp. 181-217.
29. Ross, G.T., R.M. Soland, "Multicriteria Approach to Location of Public Facilities", European Journal of Operational Research, Vol. 4, May 1980, pp. 307-321.
30. Sanders, B., "Simple Approximation Techniques for the Calculation of Call Congestion in Case of Peaked or Smooth Traffic", Dr. Neher Laboratories of The Netherlands Postal And Telecommunication Services, Netherlands, July 1981, pp. 1-8.
31. Sheridan, M.J., "Optimization of Teletraffic Routing in the Planning of Telephone Networks", Irish Telecommunication Research, Technical Report, July 1980, pp. 1-31.

2. Truitt, C.J., "Traffic Engineering Techniques for Determining Trunk Requirements in Alternate Routing Trunk Networks", Bell System Technical Journal, Vol. 33, 1954, pp. 277-302.
33. Ulusoy, A.G., N. Kesen, B. Balaban, "A Mathematical Programming Package: LP-PLP-OP-BB-MIF", Department of Industrial Engineering, Boğaziçi University, December 1979, pp. 1-15.
34. Wilkinson, R.I., "Theories for Toll Traffic Engineering in the U.S.A.", Bell System Technical Journal, Vol.35, 1956, pp. 421-514.

APPENDICES

APPENDIX A

DERIVATION OF THE OPTIMIZATION EQUATION FOR EXAMPLARY CASES

A.I. TRIANGULAR ROUTING

All the equations that will follow are based on the network of Figure A.1.

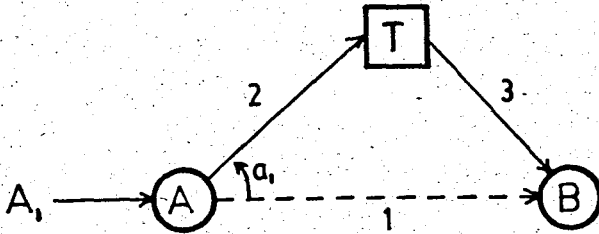

Figure A.1. First Example Network

The cost of routing the input traffic denoted by A_1 erlangs over the network is C .

$$C = C_1 \cdot N_1 + C_2 \cdot N_2 + C_3 \cdot N_3 + C_{T_T} \cdot T_T$$

C is a function of one independent variable, N_1 , since only link 1 is a high usage link. Thus,

$$\frac{\partial C}{\partial N_1} = 0$$

$$\frac{\partial C}{\partial N_1} = C_1 + C_2 \left(\frac{\partial N_2}{\partial N_1} \right) + C_3 \left(\frac{\partial N_3}{\partial N_1} \right) + C_{T_T} \left(\frac{\partial T_T}{\partial N_1} \right)$$

$$0 = C_1 + C_2 \left(\frac{\partial N_2}{\partial a_1} \right) b_2 \left(\frac{\partial a_1}{\partial N_1} \right) A_1 + C_3 \left(\frac{\partial N_3}{\partial a_1} \right) b_3 \left(\frac{\partial a_1}{\partial N_1} \right) A_1 + C_{T_T} \left(\frac{\partial T_T}{\partial N_1} \right)$$

However, $T_T = T_T(a_1, A_1) \equiv a_1$ for this simple triangular network since it is assumed that the additional tandem traffic flowing through the tandem switching center is due to the additional overflow from the first choice link. A_1 is considered to be constant.

If $T_T = a_1,$

then $\frac{\partial T_T}{\partial N_1} = \left(\frac{\partial a_1}{\partial N_1} \right) A_1$

Consequently, the following substitutions are made by using the definitions given in section V.3.2.

$$\left(\frac{\partial a_1}{\partial N_1} \right) A_1 = -H_1$$

$$\left(\frac{\partial N_k}{\partial a_r} \right) b_k = \frac{1}{\beta_k}$$

The above equation holds since the change in the offered traffic of link k is given by the change in a_r , for r equaling 1 or 3 in this case.

Thus,

$$0 = C_1 - \frac{C_2 \cdot H_1}{\beta_2} - \frac{C_3 \cdot H_1}{\beta_3} - C_{T_T} \cdot H_1$$

$$\frac{C_1}{H_1} = \frac{C_2}{\beta_2} + \frac{C_3}{\beta_3} + C_{T_T} \tag{A.1}$$

A.II. TWO OVERFLOW POSSIBILITIES

All the equations that will follow are based on the network of Figure A.2.

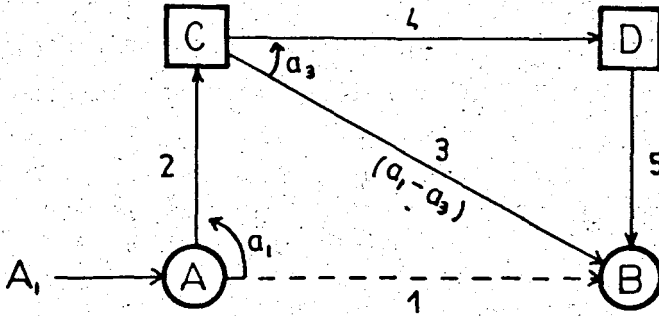

Figure A.2. Second Example Network

The cost of routing the input traffic denoted by A_1 erlangs over the network is C .

$$C = \sum_{i=1}^5 C_i \cdot N_i + CT_C \cdot T_C + CT_D \cdot T_D$$

C is a function of two independent variables, N_1 and N_3 , since link 1 and 3 are the high usage links. The optimization equation of link 1 is given by (A.2) and that of link 3 is given by (A.3).

$$\left(\frac{\partial C}{\partial N_1} \right)_{N_3} = 0 \quad (A.2)$$

$$\left(\frac{\partial C}{\partial N_3} \right)_{N_1} = 0 \quad (A.3)$$

To obtain the open form of the optimization equations the partial derivatives are taken.

$$\begin{aligned} \left(\frac{\partial C}{\partial N_1} \right)_{N_3} &= C_1 + C_2 \left(\frac{\partial N_2}{\partial N_1} \right)_{N_3} + C_3 \left(\frac{\partial N_3}{\partial N_1} \right)_{N_3} \\ &\quad + C_4 \left(\frac{\partial N_4}{\partial N_1} \right)_{N_3} + C_5 \left(\frac{\partial N_5}{\partial N_1} \right)_{N_3} \\ &\quad + CT_C \left(\frac{\partial T_C}{\partial N_1} \right)_{N_3} + CT_D \left(\frac{\partial T_D}{\partial N_1} \right)_{N_3} \end{aligned}$$

obviously, $(\frac{\partial N_3}{\partial N_1})_{N_3} = 0$

The additional tandem traffic flowing through the tandem switching center "C" is due to the additional overflow from the first choice link. However, the additional tandem traffic flowing through the tandem switching center "D" depends on both of the two overflow values a_1 and a_2 .

$$\begin{aligned}
 0 = & C_1 + C_2 \left(\frac{\partial N_2}{\partial a_1}\right)_{b_2} \left(\frac{\partial a_1}{\partial N_1}\right)_{A_1} + C_4 \left(\frac{\partial N_4}{\partial a_3}\right)_{b_4} \left(\frac{\partial a_3}{\partial a_1}\right)_{N_3} \left(\frac{\partial a_1}{\partial N_1}\right)_{A_1} \\
 & + C_5 \left(\frac{\partial N_5}{\partial a_3}\right)_{b_5} \left(\frac{\partial a_3}{\partial a_1}\right)_{N_3} \left(\frac{\partial a_1}{\partial N_1}\right)_{A_1} + CT_C \left(\frac{\partial a_1}{\partial N_1}\right)_{A_1} \\
 & + CT_D \left(\frac{\partial a_3}{\partial a_1}\right)_{N_3} \left(\frac{\partial a_1}{\partial N_1}\right)_{A_1}
 \end{aligned}$$

In addition to the two substitution equations given in section A.1, the following definition has to be included.

$$\left(\frac{\partial a_3}{\partial a_1}\right)_{N_3} = \gamma_3$$

Therefore,

$$0 = C_1 - \frac{C_2 \cdot H_1}{\beta_2} - \frac{C_4 \cdot H_1}{\beta_4} \cdot \gamma_3 - \frac{C_5 \cdot H_1}{\beta_5} \cdot \gamma_3 - CT_C \cdot H_1 - CT_D \cdot H_1 \cdot \gamma_3$$

$$\frac{C_1}{H_1} = \frac{C_2}{\beta_2} + \frac{C_4}{\beta_4} \cdot \gamma_3 + \frac{C_5}{\beta_5} \cdot \gamma_3 + CT_C + CT_D \cdot \gamma_3 \quad (A.4)$$

A similar reasoning is used to obtain the second optimization equation. It should be noted that,

$$\left(\frac{\partial N_2}{\partial N_3}\right)_{N_1} = 0$$

If A_1 and N_1 are constant, then a_1 is not varying. Hence, this implies that b_2 is constant for a specified blocking value. A similar reasoning applies for considering the additional tandem traffic flowing through the tandem switching center "C" as being null for this case. In turn, A_3 is kept constant since the lower portion of the network is not liable to variation.

$$\left(\frac{\partial C}{\partial N_3} \right)_{N_1} = C_3 + C_4 \left(\frac{\partial N_4}{\partial N_3} \right)_{N_1} + C_5 \left(\frac{\partial N_5}{\partial N_3} \right)_{N_1} + CT_D \left(\frac{\partial T_D}{\partial N_3} \right)_{N_1}$$

$$0 = C_3 + C_4 \left(\frac{\partial N_4}{\partial a_3} \right)_{b_4} \left(\frac{\partial a_3}{\partial N_3} \right)_{A_3} + C_5 \left(\frac{\partial N_5}{\partial a_3} \right)_{b_5} \left(\frac{\partial a_3}{\partial N_3} \right)_{A_3}$$

$$+ CT_D \left(\frac{\partial a_3}{\partial N_3} \right)_{A_3}$$

Therefore,

$$\frac{C_3}{H_3} = \frac{C_4}{\beta_4} + \frac{C_5}{\beta_5} + CT_D \quad (A.5)$$

Proceeding in this manner by taking the derivative of the cost function with respect to the independent variables in order to find the optimization equations, is obviously tedious. Especially, when there are a great number of high usage links, the number of derivatives to be taken directly increase. Therefore, in applications instead of taking derivatives, equation (V.11), which yields easily to computerization, can be utilized. To clarify the usage of equation (V.11), some further explanation is necessary†. As an example problem, second example illustrated by Figure A.2 is considered since it is more complex and complete than the first example.

For the design of high usage link 1, consider Figure A.3.

† The underlying basis relating to the discussion which will henceforth issue is due to Sheridan [31]. In this section of the thesis, his resolution scheme is applied to a particular example.

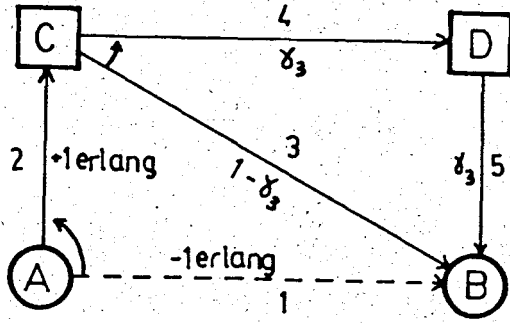

Figure A.3. Marginal Overflows in the Design of Link 1

This marginal overflow representation may be explained as follows. If it is required to dimension link 1 in terms of H_1 , consider one marginal erlang offered to the overflow network. Thus, one erlang is offered to link 2 and then to link 3, from which an amount of γ_3 is rejected to link 4. To link 5, only the traffic from link 4 is offered, therefore it is offered γ_3 . Utilizing this explanation, equation (V.11) can easily be calculated. Rewriting equation (V.11),

$$\frac{C_\ell}{H_\ell} = \sum_{k \in F_\ell} \frac{C_k}{\beta_k} \cdot XT_k + \sum_{i \in F_i} CT_i \cdot Y_i$$

In the example considered,

$$\ell = 1$$

$$F_\ell = \{ 2, 4, 5 \}$$

$$F_i = \{ C, D \}$$

The values of XT_k , the additional traffic on link k , can easily be found.

$$XT_2 = 1 \quad XT_4 = \gamma_3 \quad XT_5 = \gamma$$

Similarly, the values of Y_i , the additional traffic flowing through the tandem switching center i , can be obtained.

$$Y_C = 1 \quad Y_D = \gamma_3$$

substituting these values to equation (V.11), equation (A.I.4) is achieved.

$$\frac{C_1}{H_1} = \frac{C_2}{\beta_2} \cdot 1 + \frac{C_4}{\beta_4} \cdot \gamma_3 + \frac{C_5}{\beta_5} \cdot \gamma_3 + CT_C \cdot 1 + CT_D \cdot \gamma_3$$

To calculate the marginal occupancy of link 3 using the "marginal erlang" representation, consider the illustration of Figure A.4.

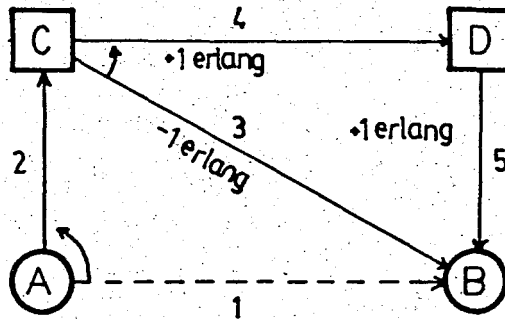

Figure A.4. Marginal Overflows in the Design of Link 3

The marginal erlang is first offered to link 4 and then to link 5.

In this case,

$$l = 3$$

$$F_l = \{ 4, 5 \}$$

$$F_i = \{ D \}$$

$$XT_4 = 1 \quad XT_5 = 1 \quad Y_D = 1$$

Hence, after substitution to equation (V.11), equation (A.5) results.

Equation (V.11) is the generalization of the optimization equations which can be used to describe any type of alternate routing network.

APPENDIX B

DERIVATION OF THE POLYGONAL FUNCTION

To derive the polygonal approximating function, the following simple reasoning and relationships are sufficient. Let the abscissa of the two consecutive integer valued points be represented by N and $N+1$. The corresponding ordinates of these two points are $B(N,A)$ and $B(N+1, A)$, respectively.

Thus, the slope of the line between these two points is given by

$$B(N+1, A) - B(N, A) = -D(N, A)$$

While the y-intercept is given by

$$B(N, A) - [B(N+1, A) - B(N, A)] N$$

$$= (N+1) B(N, A) - N B(N+1, A)$$

Substituting the expressions for the slope and the y-intercept into the well known formula of a line, equation (V.20) results.

APPENDIX C

EXAMPLES ON END-TO-END BLOCKING PROBABILITY CALCULATION

First, the triangular network of Figure A.1 is considered. The network is redrawn as a linear graph, as illustrated by Figure A.5.

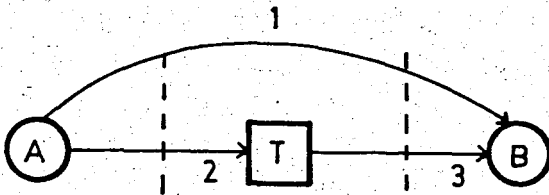

Figure A.5. Linear Graph of the First Example

Links 2 and 3 are the final links. Let the coefficients of the end-to-end blocking probability functions be denoted by CF . Then following Blaauw's reasoning, the end-to-end blocking probability for the traffic relation (A,B) is represented by (C.1).

$$E_{A,B} = CF_{A,T} b_{A,T} + CF_{T,B} b_{T,B} \quad (C.1)$$

The objective is to find the values of the coefficients $CF_{A,T}$ and $CF_{T,B}$. Then, following the simple rule that Blaauw gives, the cut is formed. In this case, only one high usage link, link 1, is cut so that equation (C.2) results.

$$E_{A,B} = \bar{b}_{A,B} b_{A,T} + \bar{b}_{A,B} b_{T,B} \quad (C.2)$$

As a second example, consider the network given by Figure A.2. The corresponding linear graph is delineated by Figure A.6.

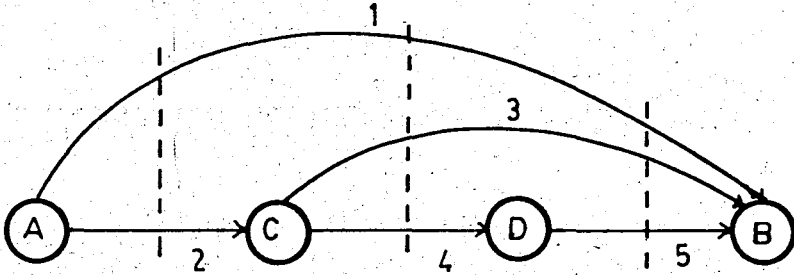

Figure A.6. Linear Graph of Second Example

Links 2, 4 and 5 are the final links. The end-to-end blocking probability for the traffic relation (A,B) is represented by (C.3).

$$E_{A,B} = CF_{A,C} b_{A,C} + CF_{C,D} b_{C,D} + CF_{D,B} b_{D,B} \quad (C.3)$$

The coefficients are found by taking the product of the high usage link blocking probabilities for those high usage links which are cut.

$$CF_{A,C} = \bar{b}_{A,B}$$

$$CF_{C,D} = CF_{D,B} = \bar{b}_{A,B} \bar{b}_{C,B}$$

Substitution of the coefficients into equation (C.3) yields the equation to obtain the end-to-end blocking probability of (A,B).

APPENDIX D

EXPLANATION OF THE COMPUTER PROGRAM

The computer program developed for the application of the dimensioning procedure consists of 31 subprograms besides the main program. Of the subprograms, 19 are the subroutines of the MATPRO package program whose explanation can be found in Reference [33]. In this section, the main program and the remaining 12 subprograms will be presented.

While using the main program, there are five options. The options denote the network structure that can be handled by the computer program. The options are indicated by the variable IPRI. For IPRI equaling one, the network contains only direct links to supply connections between the exchanges. If IPRI equals two, the network is allowed to have one overflow possibility, and the traffic for any exchange pair can pass through only one tandem switch. When IPRI is set to three, then the network is allowed to have two overflow possibilities. The network structure in the case where IPRI equals four is the same as IPRI being equal to two. The difference is that in this case, the blocking probability values for the high usage links are set equal to 0.20 without performing any optimization for the high usage links. Such a case is considered because this application resembles the current scheme of the Turkish PTT while supplying trunks between switching centers. When IPRI is equal to five, the network is again allowed to have one overflow possibility, but the traffic can pass through two tandem switches for completing the connection. The following figure can clarify the definition of IPRI.

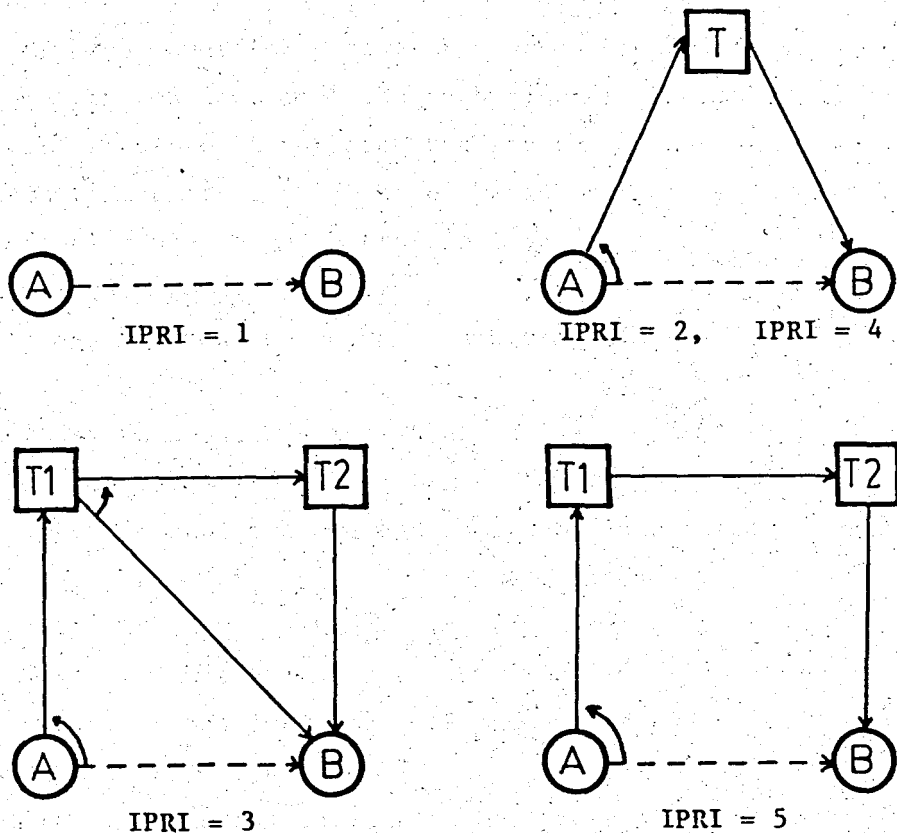

Figure A.7. The Correspondence Between the Value of IPRI and the Network Structure

The variables utilized in the computer program to designate the necessary input parameters and data are as follows.

- A(.) = Input traffic values for each exchange pair[†]
- BETA(.) = The marginal capacity parameter of a link
- BLOK(.) = The specified or determined blocking probability value of a final link

[†] Instead of specifying input traffic between two nodes as a matrix, it is represented as an array for simplicity. The traffic values are linkwise specified. If there does not exist a direct link between the calling pair, then a dummy link is introduced for indexing.

- C(.) = The cost of supplying one circuit on a link
- CT1, CT2 = The cost of one erlang flowing through the tandem switches 1 and 2
- EEB = The desired end-to-end blocking probability for each traffic relation[†]
- GAMA(.) = The marginal overflow parameter of an overflowing link
- IALT(.,.) = The matrix consisting of the numbering of the links which form the alternate route for each traffic relation
- IFIN(.,.) = The matrix consisting of the numbering of the links which form the final route for each traffic relation
- IPRI = The priority (option) number
- NA = The index to show the highest numbering of the first link in the final route
- NAA = The index to show the highest numbering of the second overflowing links
- NALT = The index to show the highest number of links in the alternate route
- NF = The index to show the number of links in the network
- NL = The index to show the highest number of links in the final route
- NT = The index to show the number of exchange pairs calling one another

The variables denoting the basic outputs of the program are as follows.

- BLK(.) = The realized blocking probability of each link
- GOS(.) = The realized grade of service value for each traffic relation
- GRAD(.) = The gradient of total network cost with respect to final link blocking probabilities
- HIT = The marginal occupancy parameter
- N(.) = The number of integer valued trunks on a link
- TCOST1 = Total investment cost under current dimensioning, considering real-valued trunk capacities
- TCOST2 = Total investment cost under current dimensioning, considering integer valued trunk capacities
- TT1, TT2 = The amount of transit traffic flowing through the tandem switches 1 and 2
- X(.) = The number of real-valued trunks on a link.

[†] The value of EEB is taken equal for all traffic relations.

It may be helpful to include the definitions for some additional variables used within the computer program.

ASTF(.) = The equivalent random traffic for a link
CARM(.) = The mean of the carried traffic on a link
CARV(.) = The variance of the carried traffic on a link
ITE = The index showing the number of the overall dimensioning iterations
ITER = The index showing the number of the dimensioning iterations
NSF(.) = The number of equivalent group of circuits for a link
OFFM(.) = The mean of the offered traffic on a link
OFFV(.) = The variance of the offered traffic on a link
OVMP(.) = The mean of the overflow traffic on a link
OVVP(.) = The variance of the overflow traffic on a link

The objectives of the subroutines and functions with their input requirements and issuing outputs are given in the following paragraphs.

SUBROUTINE BETAUP

The function of this subroutine is to calculate the new values of the marginal capacity parameters for the final links, as was discussed in section V.3.5.1. To attain the new β value, the mean of the offered traffic, the variance-to-mean ratio, the number of circuits, the number of equivalent circuits, the amount of equivalent traffic and the current value of β for the link under view are taken as inputs.

FUNCTION CARP

CARP calculates the values of terms such as $A^N/N!$ which are required for the Erlang-B formula. CARP is only called from FUNCTION ERLANG. Obviously, the inputs to CARP are the amount of traffic (A) and the number of circuits (N).

SUBROUTINE CARRY

The mean and variance of the carried traffic distributions are found in this subroutine. The amount of equivalent random traffic, the number of circuits,

the number of equivalent circuits, and the blocking probability of the link being analyzed are the necessary inputs.

SUBROUTINE DIM

The function of DIM is to calculate the number of circuits to be provided on each final link. Therefore, through subroutine DIM the final links are dimensioned. The amount of equivalent random traffic, the number of equivalent circuits and the specified final link blocking probability are considered as inputs to supply the integer valued and real-valued number of circuits for that final link.

SUBROUTINE DIMENS

The high usage links are dimensioned through the application of DIMENS, which mainly uses the value of the marginal occupancy parameter that has been calculated in the main program. The amount of equivalent random traffic, the number of equivalent circuits and the marginal occupancy parameter are taken as inputs to provide the integer valued and real-valued number of circuits for that high usage link.

FUNCTION ERLANG

In this function, the link blocking probabilities are calculated by using the Erlang-B formula. The inputs are the number of circuits, the number of equivalent circuits, and the amount of equivalent random traffic. Naturally, if the offered traffic of the link under study is random, then the number of equivalent circuits is zero, and the amount of equivalent random traffic is really the amount of offered traffic.

SUBROUTINE ERT

The equivalent random theory is applied in subroutine ERT. The outputs of ERT are the amount of equivalent random traffic and the number of equivalent circuits expressed as integer valued and real-valued. To determine the outputs, the mean and variance of the offered traffic are used.

SUBROUTINE GAMAUP

The function of this subroutine is to calculate the new values of the marginal overflow parameters for the second overflow links, as was discussed in section V.3.5.2. To obtain the new γ value, the number of circuits, the number of equivalent circuits, and the amount of equivalent random traffic of that high usage link are utilized as inputs.

SUBROUTINE MATCO2

MATCO2 is one of the two subroutines supplying the connection between the main program and the LP problem. Within MATCO2, LINP which is a subroutine of the MATPRO package program is called so that the solution of the LP problem is initiated. The new values for the final link blocking probabilities, which are the decision variables of the LP problem, are returned to MATCO2 and from there to the main program. MATCO2 is employed for those network structures with one overflow possibility. Within the subroutine, the objective function coefficients, the coefficient matrix for the constraints, and the right-hand side vectors of the constraints are generated and through the values assigned to variable TYPEC the type of inequalities are specified in order to use the MATPRO package program. To perform these steps, the inputs are denoted by NF, NT, NALT, NAA, IALT(.,.), GRAD(.), BLK(.), and EEB which have been previously defined.

SUBROUTINE MATCO3

MATCO3 is the second subroutine supplying the connection between the main program and the LP problem. Similar to MATCO2, MATCO3 calls LINP to initiate the solution of the LP problem. MATCO3 is employed for network structures with two overflow possibilities. The new values for the final link blocking probabilities which are returned to MATCO3 from the MATPRO package program are the outputs of the subroutine. The objective function coefficients, the coefficient matrix and the right-hand side vectors for the constraints, and the type of inequalities are generated within MATCO3. The way of generating the data inputs of MATPRO is different in MATCO3 and MATCO2 due to the differences in the network structures. The necessary inputs to MATCO3 are designated by NF, NT, NL, NALT, NAA, IFIN(.,.), IALT(.,.), GRAD(.), BLK(.) and EEB.

SUBROUTINE OVERFL

The mean and variance of the overflowing traffic distributions are calculated in this subroutine. The amount of equivalent random traffic, the number of circuits, and the number of equivalent circuits are the necessary inputs.

SUBROUTINE PRIOR5

Subroutine PRIOR5 is designed for IPRI equaling five. The dimensioning steps for the other four priority cases are handled within the main program without separating them into different subroutines because there are some interactions between the cases. Considering ease of calculation, it was seen fit to handle the case where priority equals five in a separate subprogram. In this case, the dimensioning steps to obtain the link capacities are carried out by PRIOR5. Then the gradient calculations are performed in the main program, and MATCO2 is called from the main program. The inputs required from the main program to perform the dimensioning steps in PRIOR5 are A(.), C(.), CT1, CT2, IALT(.,.), BETA(.), GAMA(.), NA, NAA, NT, NF, NALT, and the specified final link blocking probabilities.

APPENDIX E

EXAMPLE NETWORKS

The example networks corresponding to priority two and five are illustrated in Figure A.8 and Figure A.9, respectively.

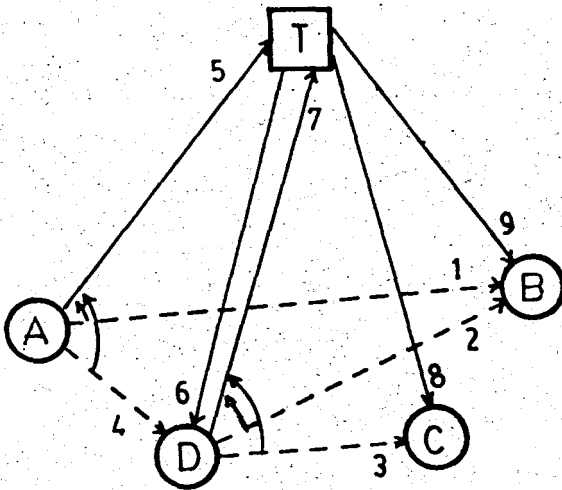

Figure A.8. The Example Network for IPRI Equaling Two

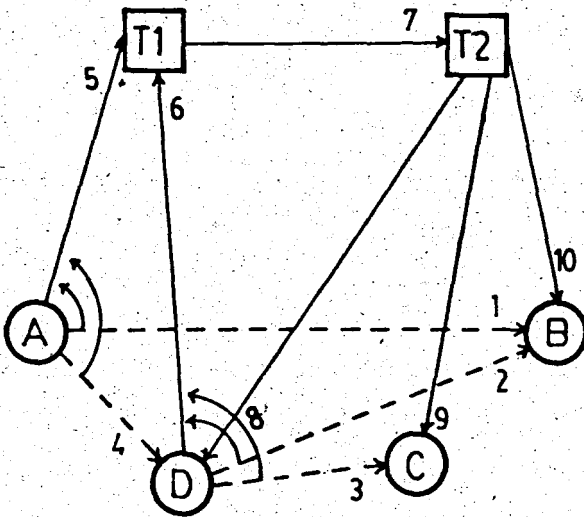

Figure A.9. The Example Network for IPRI Equaling Five

APPENDIX F

TEST NETWORKS

The test network which has a bigger size than the example network is drawn for priority equaling three.

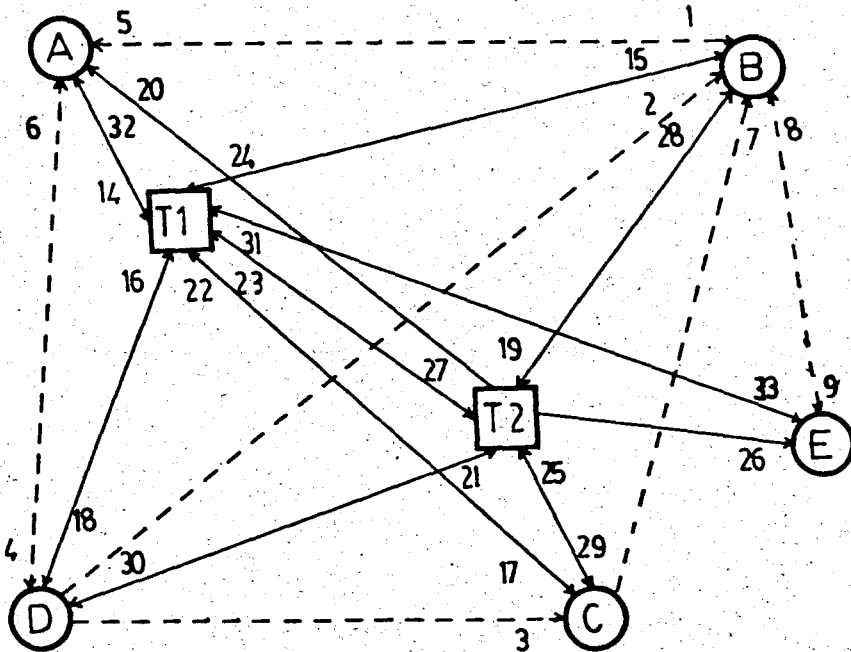

Figure A.10. The Test Network for IPRI Equaling Three

The following two tables give the description of the traffic relations, $IALT(j,r)$ and $IFIN(j,m)$ specifications for the network of Figure A.10. The arrows showing to which link, a high usage link overflows are omitted in Figure A.10 not to complicate the illustration, but the overflow routes can easily be deduced by considering $IALT(j,r)$ and $IFIN(j,m)$.

Table A.1. The Description of the Traffic Relations

Nodes Specifying Traffic Relation [†]	Traffic Relation (Direct Link) Number
(A,B)	1
(D,B)	2
(D,C)	3
(A,D)	4
(B,A)	5
(D,A)	6
(C,B)	7
(E,B)	8
(B,E)	9
(E,D)	10 ^{††}
(D,E)	11 ^{††}
(C,A)	12 ^{††}
(A,C)	13 ^{††}

† The first component is the source while the second is the sink.

†† Analyzing the network of Figure A.10, it is seen that direct links do not exist for the traffic relations (E,D), (D,E), (C,A) and (A,C). Dummy links, denoted by 10,11,12 and 13, are introduced just to describe the the traffic relations linkwise.

Table A.2. The Specification of IALT(j,r)

j \ r	1	2
1	14	15
2	16	15
3	16	17
4	14	18
5	19	20
6	21	20
7	22	15
8	23	15
9	24	26
10	23	18
11	16	26
12	25	20
13	14	17

Table A.3. The Specification of IFIN(j,m)

j \ m	1	2	3
1	14	27	28
2	16	27	28
3	16	27	29
4	14	27	30
5	19	31	32
6	21	31	32
7	22	27	28
8	23	27	28
9	24	27	33
10	23	27	30
11	16	27	33
12	25	31	32
13	14	27	29

For the test network, the following equalities need to be made for the variables.

$$NA = 25$$

$$NAA = 26$$

$$NALT = 2$$

$$NF = 33$$

$$NL = 3$$

$$NT = 13$$

The input traffic, cost, and grade of service parameter values are taken as shown in Table A.4 and A.5.

Table A.4. The Specification of Input Traffic

(erlangs)

j	A(j)
1	3.50
2	2.00
3	3.00
4	5.00
5	3.50
6	5.00
7	2.50
8	4.00
9	4.00
10	0.75
11	0.75
12	0.50
13	0.50

Table A.5. The Specification of Cost Coefficients for the Links

(TL/trunk)

Link t	C(t)	Link t	C(t)
1	2250	18	900
2	2500	19	1100
3	1300	20	1200
4	1900	21	900
5	2250	22	1400
6	1900	23	2100
7	1800	24	1400
8	1100	25	1100
9	1100	26	2100
10	0 [†]	27	800
11	0 [†]	28	1100
12	0 [†]	29	1100
13	0 [†]	30	900
14	1000	31	800
15	1400	32	1000
16	900	33	1300
17	1400		

$$CT1 = CT2 = 50 \text{ TL/erlang}$$

$$EEB = 0.01$$

The link numbering shown by Figure A.10 is kept the same for all the priority cases. Similarly, the input values given by Table A.4 and A.5 are not changed. For priority two case, IALT(j,r) are taken as in Table A.2. For this priority, IFIN(j,m) specification is not required since final routes besides the alternate routes are not to be utilized. For priority four case, the data and input specifications are exactly the same as those of priority two case.

For priority five case, NALT is changed to 3 and NAA to 33. The specification of IALT(j,r) is given by Table A.3. So, the final link set of the priority three case constitute the alternate routes of the priority five case.

† No cost is incurred since these are dummy links.

APPENDIX G

SOME PERTINENT RESULTS OF THE TEST NETWORK

Table A.6. Optimal Results for Priority 3 of the Test Network

Link t	BLK(t)	X	N
1	.4021	2.55	3
2	1.0000	.08	0
3	.2061	4.02	4
4	.2849	4.61	5
5	.5765	1.98	2
6	.3983	4.17	4
7	.2822	2.63	3
8	.1172	6.43	6
9	.1172	5.90	6
10 [†]	1.0000	.00	0
11 [†]	1.0000	.00	0
12 [†]	1.0000	.00	0
13 [†]	1.0000	.00	0
14	.0059	10.49	10
15	.1675	10.13	10
16	.0054	10.34	10
17	.3577	1.50	2
18	.1499	5.96	6
19	.0091	7.21	7
20	.1914	10.48	10
21	.0128	7.36	7
22	.0175	4.12	4
23	.0107	5.44	5
24	.0759	0.53	1
25	.0016	4.50	4
26	.5166	3.13	3
27	.0019	15.39	15
28	.0375	7.19	7
29	.0098	5.31	5
30	.0052	6.32	6
31	.0042	9.47	9
32	.0591	13.90	14
33	.0127	11.44	11

[†] Links 10,11,12 and 13 shown in tables A.6 to A.9 are dummy links.

Table A.7. Optimal Results for Priority 2 of the Test Network

Link t	BLK(t)	X	N
1	.7778	1.18	1
2	1.0000	.00	0
3	.2061	3.70	4
4	.6757	2.48	2
5	.7778	1.23	1
6	.5297	3.47	3
7	.4717	2.47	2
8	.1172	6.29	6
9	.1172	5.88	6
10	1.0000	.00	0
11	1.0000	.00	0
12	1.0000	.00	0
13	1.0000	.00	0
14	.0017	16.22	16
15	.0093	17.04	17
16	.0054	10.34	10
17	.0092	6.21	6
18	.0102	12.11	12
19	.0076	8.20	8
20	.0136	16.45	16
21	.0113	8.26	8
22	.0154	5.44	5
23	.0034	6.48	6
24	.0759	0.53	1
25	.0016	4.50	4
26	.0066	11.37	11

Table A.8. Optimal Results for Priority 4 of the Test Network

Link t	BLK(t)	X	N
1	.1541	5.42	5
2	.0952	4.06	4
3	.2061	4.04	4
4	.1919	5.91	6
5	.1541	5.42	5
6	.1919	5.91	6
7	.1499	4.43	4
8	.1991	4.99	5
9	.1991	4.99	5
10	1.0000	.00	0
11	1.0000	.00	0
12	1.0000	.00	0
13	1.0000	.00	0
14	.0127	7.21	7
15	.0341	10.99	11
16	.0025	7.47	7
17	.0031	8.49	8
18	.0067	10.37	10
19	.0544	2.01	2
20	.0083	16.90	17
21	.0281	4.15	4
22	.0159	3.22	3
23	.0052	7.47	7
24	.0448	3.00	3
25	.0016	4.50	4
26	.0077	12.46	12

Table A.9. Optimal Results for Priority 5 of the Test Network

Link t	BLK(t)	X	N
1	.4021	2.75	3
2	1.0000	0.15	0
3	.2061	3.91	4
4	.2849	5.15	5
5	.4021	3.10	3
6	.2849	5.19	5
7	.2822	2.72	3
8	.1172	6.36	6
9	.1172	5.97	6
10	1.0000	.00	0
11	1.0000	.00	0
12	1.0000	.00	0
13	1.0000	.00	0
14 [†]	.0122	9.08	9
16	.0054	10.21	10
19	.0257	5.10	5
21	.0285	5.36	5
22	.0175	4.48	4
23	.0107	5.48	5
24	.0759	1.41	1
25	.0127	3.49	3
27	.0012	34.20	34
28	.0022	16.47	16
29	.0020	7.37	7
30	.0035	10.50	10
31	.0012	20.13	20
32	.0024	9.35	9
33	.0031	7.43	7

[†] Links 15,17,18,20 and 26 are not existent in the network structure corresponding to priority five.

APPENDIX H
LISTING OF THE COMPUTER PROGRAM

```

DIMENSION A(13), IALT(13,5), IFIN(13,4), C(33), BETA(33), BLOK(40)
DIMENSION OFFM(33), OFFV(33), CD(25), OFFMP(33,33), OFFVP(33,33),
*VMP(33,33), IND(40), COUF(40), RHS(30), RMS(30,40)
DIMENSION OVVP(33,33), CONSM(32,33), CONSV(32,33), INDEX(33), Q(33)
*X(33), BLK(34), GOS(13), ASTF(33), NSF(33), GRAD(33), GAMA(30)
DIMENSION NI(33), CARM(33), CARV(33), INDEX2(33), SSO(25), SUMSQ(25)
DIMENSION SG(15), SSG(15)
DATA NT, NF, NL, NA, NAA/13, 33, 5, 25, 33/
XR=5
XW=6
YTF=2
SSG(1)=0.
VALT=3
CEB=0.01
READ(KR,77) IPRI
7 FORMAT(I7)
IF(IPRI.NE.3) GO TO 600
DIMENSIONING STEPS FOR PRIORITY 3
READ(KR,1) (A(IT), IT=1, NT)
1 FORMAT(8F10.2)
READ(KR,2) ((IALT(IT,J), IT=1, NT), J=1, VALT)
2 FORMAT(16I5)
READ(KR,3) ((IFIN(IT,J), IT=1, NT), J=1, NL)
3 FORMAT(16I5)
READ(KR,35) (C(I), I=1, NF)
15 FORMAT(8F10.2)
READ(KR,36) CT1, CT2
36 FORMAT(2F10.2)
ITER=1
SSQ(ITER)=0.
DO 7 IT=1, NT
DO 8 J=1, NL
IN=IFIN(IT, J)
IF(IN.EQ.0) GO TO 7
BETA(IN)=0.8
6 BLOK(IN)=0.01
7 CONTINUE
DO 25 IT=1, NT
I1=IAI T(IT, 1)
I2=IAI T(IT, 2)
BLOK(I1)=0.005
25 GAMA(I2)=0.6
33 ITER=ITER+1
DO 10 I=1, NF
OFFM(I)=0.
10 OFFV(I)=0.
CALCULATION OF THE MARGINAL CAPACITY PARAMETER FOR DIRECT LINKS
DO 11 IT=1, NT
I1=IAI T(IT, 1)
I2=IAI T(IT, 2)
TERM1=C(I1)/BETA(I1)
TERMS=0.
DO 30 J=1, NL
IL=IFIN(IT, J)
IF(JL.EQ.0) GO TO 31
TERMS=TERMS+(C(JL)/BETA(JL))*GAMA(I2)
30 CONTINUE
31 CD(I1)=TERM1+TERMS+CT1+CT2*GAMA(I2)
HIT=C(IT)/CD(IT)

```

```

WRITE(KW,32) IT,HIT
FORMAT(/,10X,,THE MARGINAL CAPACITY OF LINK,,I3,,I5,,F5.2)
IF(HIT.EQ.0.) GO TO 27
IF(HIT.LT.1.) GO TO 26
NI(IT)=0
WRITE(KW,4) IT,ITER
BLK(IT)=1.
WRITE(KW,18) IT,ITER,BLK(IT)
FORMAT(/,10X,,LINK,,2X,I3,2X,,SHOULD NOT BE CONSTRUCTED AT ITERA
TION,,I2)
OFFMP(I1,IT)=A(IT)
OFFVP(I1,IT)=A(IT)
OFFM(I1)=OFFM(I1)+OFFMP(I1,IT)
OFFV(I1)=OFFV(I1)+OFFVP(I1,IT)
OVMP(I1,IT)=OFFMP(I1,IT)
OVVP(I1,IT)=OFFVP(I1,IT)
GO TO 11
AT=A(IT)
NS=0
STN=0
CALL DIMENS(HIT,AT,NS,STN,XI,NI)
X(IT)=XI
NI(NI)=NI-I
CALL OVERFL(AT,XI,NI,OVMP,OVVP,ER)
BLK(IT)=ER
WRITE(KW,18) IT,ITER,BLK(IT)
OVMP(I1,IT)=OVMP
OVVP(I1,IT)=OVVP
OFFM(I1)=OFFM(I1)+OVMP(I1,IT)
OFFV(I1)=OFFV(I1)+OVVP(I1,IT)
CONTINUE
CALCULATION OF WEIGHT FACTORS 1
DO 13 I=1,NT
I1=IAI I(I,1)
I1=IAI I(I,2)
SUMM=0.
SUMV=0.
DO 14 J=1,NT
IF(I1.NE.IALT(J,1)) GO TO 14
SUMM=SUMM+OVMP(I1,J)
SUMV=SUMV+OVVP(I1,J)
CONTINUE
CONSM(I1,J1)=OVMP(I1,I)/SUMM
CONSV(I1,J1)=OVVP(I1,I)/SUMV
CONTINUE
DO 15 K=1,NA
INDEX(K)=0
DO 16 IT=1,NT
I1=IAI I(IT,1)
IF(INDEX(I1).EQ.1) GO TO 16
Q(IT)=OFFV(I1)/OFFM(I1)
WRITE(KW,703) I1,ITER,Q(IT)
FORMAT(/,10X,,Q(,I3,,) AT ITERATION,,I3,2X,,I5,,F5.3)
OFFVS=OFFV(I1)
OFFMS=OFFM(I1)
IF(Q(IT).LE.1.) GO TO 701
CALL FRT(OFFVS,OFFMS,AST,STN,NS)
ASTF(IT)=AST
NSF(I1)=NS
GO TO 702

```

```

NS=0
NTN=0
AST=OFFM(I1)
ASTF(I1)=AST
NSF(I1)=NS
Q(I1)=1.
BLOKS=BLK(I1)
CALL DIM(BLOKS,STN,NS,AST,XI,NII)
2 X(I1)=XI
NI(I1)=NTI
NFE=NS+NI
BLK(I1)=FRLANG(NFE,AST)
IF(BLK(I1).GT.(BLOK(I1)+0.005)) GO TO 2000
GO TO 20n1
10 NII=NI+1
XI=XI+1.
GO TO 20n2
11 IF(NII.EQ.0)NII=1
NS=Q(I1)
BETT=BETA(I1)
CALL BETAUP(QS,OFFMS,NS,NII,AST,BETT,BETAS)
BETA(I1)=BETAS
WRITE(KW,140) I1,ITER,BETAS
40 FORMAT(/,10X',BETA(',I3,',) AT ITERATION,,I3',IS,,F5.3)
BLOKS=BLK(I1)
CALL CARRY(AST,BLOKS,NS,NII,CARMS,CARV,S)
CARM(I1)=CARMS
CARV(I1)=CARV
WRITE(KW,18) I1,ITER,BLK(I1)
18 FORMAT(/,10X',THE FINAL LINK',2X,I3,2V',BLOCKING AT ITERATION,,2
*X,I3,5X,F7.5)
DO 17 J=1,NT
IF(I1.NE.IALT(J,1)) GO TO 17
I1=IAIT(J,2)
OFFM(J1)=OFFM(J1)+CONSM(I1,J1)*CARM(I1)
OFFV(J1)=OFFV(J1)+CONSV(I1,J1)*CARV(I1)
17 CONTINUE
INDEX(I1)=1
16 CONTINUE
DO 19 I=1,NAA
19 INDEX(I)=0
CALCULATION OF THE MARGINAL CAPACITY PARAMETER FOR SECOND
OVERFLOW LINKS
DO 20 IT=1,NT
<2=IFTN(IT,2)
+2=IAIT(IT,2)
IF(INDEX(I2).EQ.1) GO TO 20
TERMS=0.
DO 37 J=2,NL
JL=IFTN(IT,J)
IF(JL.EQ.0) GO TO 38
TERMS=TERMS+C(JL)/BETA(JL)
37 CONTINUE
38 CD(I2)=TERMS+CT2
HIT=C(I2)/CD(I2)
WRITE(KW,32) I2,HIT
INDEX(I2)=1
IF(HIT.LT.1) GO TO 21
22 GAMMA(I2)=1.
IT(IT)=0

```

```

WRITE(KW,4) I2,ITER
BLK(I2)=1.
WRITE(KW,18) I2,ITER,BLK(I2)
OFFMP(K2,I2)=OFFM(I2)
OFFVP(K2,I2)=OFFV(I2)
OFFM(K2)=OFFM(K2)+OFFMP(K2,I2)
OFFV(K2)=OFFV(K2)+OFFVP(K2,I2)
OVMP(K2,I2)=OFFMP(K2,I2)
OVVP(K2,I2)=OFFVP(K2,I2)
GO TO 20
OFFVS=OFFV(I2)
OFFMS=OFFM(I2)
Q(I2)=OFFVS/OFFMS
WRITE(KW,703) I2,ITER,Q(I2)
IF(Q(I2).LE.1.)GO TO 801
CALL FRT(OFFVS,OFFMS,AST,STN,NS)
GO TO 802
NS,STN=0
AST=OFFM(I2)
F1=ERI ANG(NS,AST)
NSS1=NS+1
F2=ERI ANG(NSS1,AST)
HLIM=AST*(E1-E2)
IF(HIT.GF.HLIM) GO TO 22
CALL DIMENS(HIT,AST,NS,STN,XI,NII)
X(I2)=XI
NI(I2)=NII
IF(INIT.EQ.0)GO TO 22
NNK=NI(I2)
CALL GAMAP(AST,NS,NNK,GAMAS)
GAMA(I2)=GAMAS
WRITE(KW,141) I2,ITER,GAMAS
1 FORMAT(/,10X,GAMMA(,I3,,) AT ITERATION,,2X,I3,,IS,,F5.3)
XK=X(I2)
NFE=NNK+NS
CALL OVERFL(AST,XK,NFF,OVMP,OVVP,ER)
BLK(I2)=ER
WRITE(KW,18) I2,ITER,BLK(I2)
OVMP(K2,I2)=OVMP
OVVP(K2,I2)=OVVP
OFFM(K2)=OFFM(K2)+OVMP(K2,I2)
OFFV(K2)=OFFV(K2)+OVVP(K2,I2)
0 CONTINUE
DIMENSION SECOND LINK OF FINAL ROUTE
DO 23 K=1,NF
3 INDEX(K)=0
DO 24 IT=1,NT
K2=IFITN(IT,2)
IF(INDEX(K2).EQ.1) GO TO 24
Q(K2)=OFFV(K2)/OFFM(K2)
WRITE(KW,703) K2,ITER,Q(K2)
OFFVS=OFFV(K2)
OFFMS=OFFM(K2)
IF(Q(K2).LE.1.)GO TO 901
CALL FRT(OFFVS,OFFMS,AST,STN,NS)
AST(K2)=AST
NS(K2)=NS
GO TO 902
NS,STN=0
AST=OFFM(K2)

```

```

ΔSTF(K2)=AST
NSF(K2)=NS
Q(K2)=1.
BLOKS=BLK(K2)
CALL DIM(BLOKS,STN,NS,AST,XI,NII)
X(K2)=XI
NI(K2)=NTI
NFF=NS+NTI
BLK(K2)=FRLANG(NFE,AST)
TF(BLK(K2).GT.(BLOK(K2)+0.005)) GO TO 20n3
GO TO 20n4
3 NII=NTI+1
XI=XI+1.
GO TO 20n5
4 TF(NIT.EQ.0)NII=1
QS=Q(K2)
BETT=BETA(K2)
CALL BETAUP(QS,OFFMS,NS,NI,AST,BETT,BETAS)
BETA(K2)=BETAS
WRITE(KW,140) K2,ITER,BETAS
BLOKS=BLK(K2)
CALL CARRY(AST,BLOKS,NS,NII,CARMS,CARVS)
CARM(K2)=CARMS
CARV(K2)=CARVS
WRITE(KW,18) K2,ITER,BLK(K2)
INDEX(K2)=1
14 CONTINUE
HANDLING THE OTHER LINKS IN FINAL ROUTES
CALCULATION OF WEIGHT FACTORS 2
I=2
J1=3
DO 125 K=1,NF
25 INDEX2(K)=0
DO 106 I=1,NT
DO 107 K=1,NF
17 INDEX(K)=0
SUMMN=0.
SUMVN=0.
SUMMD=0.
SUMVD=0.
IFIX=IFIN(I,I1)
IFIX=IFIN(I,J1)
IF(JFIX.EQ.0) GO TO 100
IF(J1.GT.3) GO TO 104
MFIX=IFIX
GO TO 105
04 MFIX=IFIN(I,I11)
05 IF(MFIX.EQ.0.OR.IFIX.EQ.0) GO TO 100
DO 110 J=1,NT
IF(IFIX.NE.IFIN(J,I1)) GO TO 110
M1=IAI T(J,2)
IF(INDEX(M1).EQ.1) GO TO 110
SUMMD=SUMMD+OVMP(IFIX,M1)
SUMVD=SUMVD+OVVP(IFIX,M1)
IF(JFIX.NE.IFIN(J,J1)) GO TO 109
SUMMN=SUMMN+OVMP(IFIX,M1)
SUMVN=SUMVN+OVVP(IFIX,M1)
09 INDEX(M1)=1
10 CONTINUE
IF(SUMMD.EQ.0.) GO TO 100

```

```

CONSM(MFIX,JFIX)=SUMMN/SUMMD
CONSV(MFIX,JFIX)=SUMVN/SUMVD
IF(INDEX2(JFIX).EQ.1) GO TO 100
INDEX2(JFIX)=1
OFFM(JFIX)=CONSM(MFIX,JFIX)*CARM(MFIX)
OFFV(JFIX)=CONSV(MFIX,JFIX)*CARV(MFIX)
Q(JFIX)=OFFV(JFIX)/OFFM(JFIX)
WRITE(KW,703) JFIX,ITER,Q(JFIX)
OFFVS=OFFV(JFIX)
OFFMS=OFFM(JFIX)
IF(Q(JFIX).LE.1.)GO TO 1001
CALL FRT(OFFVS,OFFMS,AST,STN,NS)
ASTF(JFIX)=AST
NSF(JFIX)=NS
GO TO 1002
001 NS,STN=0
AST=OFFM(JFIX)
ASTF(JFIX)=AST
NSF(JFIX)=NS
Q(JFIX)=1.
002 BLOKS=BLOK(JFIX)
CALL RIM(BLOKS,STN,NS,AST,XI,NII)
008 X(JFIX)=XI
NI(JFIX)=NII
NFE=NC+NJI
BLK(JFIX)=ERLANG(NFE,AST)
IF(BLK(JFIX).GT.(BLOK(JFIX)+0.005)) GO TO 2006
GO TO 2007
006 NII=NII+1
XI=XI+1.
GO TO 2008
007 IF(NII.EQ.0)NII=1
QS=Q(JFIX)
BETT=BETA(JFIX)
CALL RETAUP(QS,OFFMS,NS,NII,AST,BETT,BETAS)
BETA(JFIX)=BETAS
WRITE(KW,140) JFIX,ITER,BETAS
BLOKS=BLK(JFIX)
CALL CARRY(AST,BLOKS,NS,NII,CARMS,CARVS)
CARM(JFIX)=CARMS
CARV(JFIX)=CARVS
WRITE(KW,181) JFIX,ITER,BLK(JFIX)
100 CONTINUE
J1=J1
J1=J1+1
IF(J1.GT.NE) GO TO 130
GO TO 120
130 SUMSQ(ITER)=0.
DO 131 M=1,NF
SUMSQ(ITER)=SUMSQ(ITER)+X(M)**2
131 SSQ(ITER)=SQRT(SUMSQ(ITER))
COST1=0.
COST2=0.
DO 132 I=1,NF
COST1=COST1+C(I)*X(I)
COST2=COST2+C(I)*NI(I)
132 CONTINUE
DO 133 K=1,NA
133 INDEX(K)=0
CALCULATION OF TRAFFIC PASSING THROUGH THE TANDEM SWITCHES

```

```

TT1=0.
TT2=0.
DO 134 I=1,NT
T1=I*NT(T,T,1)
K2=IFIN(T,2)
IF(INDEX(I1).EQ.1) GO TO 142
TT1=TT1+CARM(I1)
INDEX(I1)=1
2 IF(INDEX(K2).EQ.1) GO TO 134
TT2=TT2+CARM(K2)
INDEX(K2)=1
4 CONTINUE
WRITE(KW,143) TT1,TT2
3 FORMAT(/,10X,'TRAFFIC SWITCHED BY THE TWO TANDEMS ARE',3X,F10.
*2,2X,F10.2)
TCOST1=COST1+CT1*TT1+CT2*TT2
TCOST2=COST2+CT1*TT1+CT2*TT2
DO 625 I=1,NF
WRITE(KW,626) I,NI(I),X(I)
25 CONTINUE
26 FORMAT(/,5X,'NI AND XI FOR LINK',2X,I3,3X,I3,2X,F5.2)
WRITE(KW,135) ITER,TCOST1,TCOST2
35 FORMAT(/,10X,'THE ITERATION NUMBER FOR STABILIZATION IS',I5,'TH
* TOTAL NETWORK COSTS ARE',5X,F15.1,2X,F15.1)
IF(ITER.GE.3) GO TO 340
IF(ITER.GT.5) GO TO 340
IF(ABS(SSQ(ITER)-SSQ(ITER-1)).GT.1.) GO TO 333
CALCULATION OF THE REALIZED GRADE OF SERVICE LEVEL
40 DO 903 I=1,NT
IN1=IALT(I,1)
IN2=IALT(I,2)
KN2=IFIN(I,2)
KN3=IFIN(I,3)
KN4=IFIN(I,4)
IF(KN4.NE.0) GO TO 904
KN4=10
BLK(KN4)=0.
94 RT1=BIK(I)*BLK(IN1)
RT2=BIK(I)*BLK(IN2)*BLK(KN2)
RT3=BIK(I)*BLK(IN2)*BLK(KN3)
RT4=BIK(I)*BLK(IN2)*BLK(KN4)
GOS(I)=RT1+RT2+RT3+RT4
WRITE(KW,905) I,GOS(I)
95 FORMAT(/,5X,'GOS FOR RELATION',2X,I2,2X,F5.3)
93 CONTINUE
CALCULATION OF GRADIENTS
SG(ITER)=0.
DO 704 K=1,NF
94 INDEX2(K)=0
DO 705 I=1,NT
DO 706 K=1,NL
IJ=IFIN(I,K)
IF(IJ.EQ.0) GO TO 706
IF(INDEX2(IJ).EQ.1) GO TO 706
INDEX2(IJ)=1
NHF=NT(I,I)+NSF(IJ)
NHF1=NHF+1
AH=ASTF(IJ)
HF1=ERLANG(NHF,AH)
HF2=ERLANG(NHF1,AH)

```

```

4 DIF=HF1-HF2
4 HF=ABC(ACTF(IJ)*HDIF)
4 WRITE(KW,721) IJ, HF
1 FORMAT(/,10X,,H FOR FINAL LINK,,2X,I3,2X,,IS,,2X,F5.3)
GRAD(IJ)=C(IJ)*(ASTF(IJ)/HF)
4 WRITE(KW,707) IJ,GRAD(IJ)
7 FORMAT(/,10X,,GRADIENT FOR LINK,,2X,I3,2X,,IS,,2X,F10.2)
CG(ITE)=CG(ITE)+GRAD(IJ)**2
6 CONTINUE
5 CONTINUE
4 WRITE(KW,714) (NSF(I),I=NT+1,NF)
4 WRITE(KW,715) (ASTF(I),I=NT+1,NF)
4 FORMAT(/,16I5)
5 FORMAT(/,8F6.2)
4 WRITE(KW,1050) (OFFM(I),I=NT+1,NF)
4 WRITE(KW,1051) (OFFV(I),I=NT+1,NF)
4 WRITE(KW,1052) (CARM(I),I=NT+1,NF)
4 WRITE(KW,1053) (CARV(I),I=NT+1,NF)
10 FORMAT(/,5X,,OFM,,2X,8F7.2)
11 FORMAT(/,5X,,OFV,,2X,8F7.2)
12 FORMAT(/,5X,,CM,,2X,8F7.2)
13 FORMAT(/,5X,,CV,,2X,8F7.2)
SSG(ITE)=SQRT(SG(ITE))
4 WRITE(KW,708) SSG(ITE)
16 FORMAT(/,5X,,TOTAL GRADIENT FACTOR FOR SYSTEM,,2X,F10.2)
CEKUP=ABC(SSG(ITE)-SSG(ITE-1))
CEK=CEKUP/SSG(ITE)
IF(CEK,LF,0.05) GO TO 555
IF(SSG(ITE).LE.5000.) GO TO 555
IF(ITE.LT.5) GO TO 633
IF((SCG(ITE)-SSG(ITE-1)).GT.0.0) GO TO 555
IF(ITE.EQ.8) GO TO 555
33 CALL MATCO3(NF,NT,NL,IFIN,GRAD,EEB,BLK,IALT,NALT,NAA,BLOK)
ITE=ITE+1
ITER=1
DO 35 I=NT+13,NF
OFFM(I)=0.
33 OFFV(I)=0.
OFFM(15)=0.
OFFM(17)=0.
OFFM(18)=0.
OFFM(20)=0.
OFFV(15)=0.
OFFV(17)=0.
OFFV(18)=0.
OFFV(20)=0.
GO TO 343
00 IF(IPRI,HE,2) GO TO 750
DIMENSIONING STEPS FOR PRIORITY 2
READ(KR,1) (A(IT),IT=1,NT)
READ(KR,2) ((IALT(IT,J),IT=1,NT),J=1,NALT)
READ(KR,35) (C(I),I=1,NAA)
READ(KR,601) CT1
01 FORMAT(F10.2)
ITER=1
CSQ(ITER)=0.
DO 602 IT=1,NT
DO 603 J=1,NALT
IN=IALT(IT,J)
ACTA(IN)=0.8

```

```

RLK(IT,N)=0.01
CONTINUE
DO 604 IT=1,NT
TI=IAIT(TT,1)
RLK(IT,1)=0.005
ITER=ITER+1
DO 605 I=1,NAA
OFFM(I)=0.
OFFV(I)=0.
CALCULATION OF THE MARGINAL CAPACITY PARAMETER
DO 606 IT=1,NT
TI=IAIT(TT,1)
T2=IAIT(TT,2)
TERM1=C(T1)/BETA(I1)
TERM2=C(T2)/BETA(I2)
CD(IT)=TERM1+TERM2+CTI
HIT=C(IT)/CD(IT)
WRITE(KW,32) IT,HIT
IF(HIT.EQ.0.) GO TO 623
IF(HIT.LT.1.) GO TO 607
3 VI(IT)=0
WRITE(KW,4) IT,ITER
RLK(IT)=1.
WRITE(KW,18) IT,ITER,RLK(IT)
OFFMP(I1,IT)=A(IT)
OFFVP(I1,IT)=A(IT)
OFFM(I1)=OFFM(I1)+OFFMP(I1,IT)
OFFV(I1)=OFFV(I1)+OFFVP(I1,IT)
OVMP(I1,IT)=OFFMP(I1,IT)
OVVP(I1,IT)=OFFVP(I1,IT)
GO TO 606
7 AT=A(TT)
NS,STN=0
CALL DIMENS(HIT,AT,NS,STN,XI,NII)
X(IT)=XI
VI(IT)=NT-I
CALL OVERFL(AT,XI,NII,OVMP,OVVP,ER)
RLK(IT)=FR
WRITE(KW,18) IT,ITER,RLK(IT)
OVMP(I1,IT)=OVMP(I1,IT)
OVVP(I1,IT)=OVVP(I1,IT)
OFFM(I1)=OFFM(I1)+OVMP(I1,IT)
OFFV(I1)=OFFV(I1)+OVVP(I1,IT)
16 CONTINUE
CALCULATION OF WEIGHT FACTORS
DO 608 I=1,NT
I1=IAIT(I,1)
I2=IAIT(I,2)
SUMM=0.
SUMV=0.
DO 609 J=1,NT
IF(I1.NE.IALT(J,1)) GO TO 609
SUMM=SUMM+OVMP(I1,J)
SUMV=SUMV+OVVP(I1,J)
19 CONTINUE
CONSM(I1,J1)=OVMP(I1,J1)/SUMM
CONSV(I1,J1)=OVVP(I1,J1)/SUMV
28 CONTINUE
3 DO 610 K=1,NAA
INDEX(K)=0

```

```

60 611 IT=1,NT
I1=IAI T(IT,1)
IF(INDEX(I1).EQ.1) GO TO 611
Q(T1)=OFFV(I1)/OFFM(I1)
WRITE(KW,703) I1,ITER,Q(I1)
OFFVS=OFFV(I1)
OFFMS=OFFM(I1)
IF(Q(T1).LE.1.) GO TO 612
CALL FRT(OFFVS,OFFMS,AST,STN,NS)
ASTF(T1)=AST
NSF(I1)=NS
GO TO 613
612 NS,STN=0
AST=OFFM(I1)
ASTF(T1)=AST
NSF(T1)=NS
Q(T1)=1.
613 BLOKS=BLK(I1)
CALL DIM(BLOKS,STN,NS,AST,XI,NII)
614 X(T1)=XI
NII(I1)=NII
NFF=NS+NII
BLK(I1)=FRLANG(NFF,AST)
IF(BLK(I1).GT.(BLOK(I1)+0.005)) GO TO 2009
GO TO 2010
2009 NII=NII+1
XI=XI+1.
GO TO 2011
2010 IF(NII.EQ.0) NII=1
QS=Q(T1)
BETT=BETA(I1)
CALL BETAUP(QS,OFFMS,NS,NII,AST,BETT,BETAS)
BETA(T1)=BETAS
WRITE(KW,140) I1,ITER,BETAS
BLOKS=BLK(I1)
CALL CARRY(AST,BLOKS,NS,NII,CARMS,CARVS)
CARM(T1)=CARMS
CARV(T1)=CARVS
WRITE(KW,18) I1,ITER,BLK(I1)
60 614 J=1,NT
IF(I1.NE.IALT(J,1)) GO TO 614
I1=IAI T(IT,2)
OFFM(I1)=OFFM(J1)+CONSM(I1,J1)*CARM(I1)
OFFV(I1)=OFFV(J1)+CONSV(I1,J1)*CARV(I1)
614 CONTINUE
INDEX(I1)=1
611 CONTINUE
60 615 IT=1,NT
I2=IAI T(IT,2)
IF(INDEX(I2).EQ.1) GO TO 615
INDEX(I2)=1
OFFVS=OFFV(I2)
OFFMS=OFFM(I2)
Q(I2)=OFFVS/OFFMS
WRITE(KW,703) I2,ITER,Q(I2)
IF(Q(I2).LE.1.) GO TO 616
CALL FRT(OFFVS,OFFMS,AST,STN,NS)
ASTF(T2)=AST
NSF(I2)=NS
GO TO 617

```

```

6 NS=STN=0
  AST=OFFM(I2)
  ASTF(I2)=AST
  NSF(I2)=NS
  Q(I2)=1.
7 BLOKS=BLOK(I2)
  CALL DIM(BLOKS,STN,NS,AST,XI,NII)
14 X(I2)=XI
  NI(I2)=NII
  NFF=NF+NTI
  BLK(I2)=FRLANG(NFE,AST)
  IF(BLK(I2).GT.(BLOK(I2)+0.005)) GO TO 2012
  GO TO 2013
12 NIT=NTI+1
  XI=XI+1.
  GO TO 2014
13 IF(NIT.EQ.0) NII=1
  QS=Q(I2)
  BETT=BETA(I2)
  CALL BETAUP(QS,OFFMS,NS,NII,AST,BETT,BETAS)
  BETA(2)=BETAS
  WRITE(KW,140) I2,ITER,BETAS
  WRITE(KW,18) I2,ITER,BLK(I2)
15 CONTINUE
  SUMSQ(ITER)=0.
  DO 440 M=1,NF
  SUMSQ(ITER)=SUMSQ(ITER)+X(M)**2
104 S0(ITER)=SQRT(SUMSQ(ITER))
  COST1=0.
  COST2=0.
  DO 610 I=1,NAA
  COST1=COST1+C(I)*X(I)
  COST2=COST2+C(I)*NI(I)
19 CONTINUE
  CALCULATION OF TRAFFIC PASSING THROUGH THE TANDEM SWITCH
  TT=0.
  DO 620 K=1,NA
21 INDEX(K)=0
  DO 620 I=1,NT
  TI=IA1T(I+1)
  IF(INDEX(I),EQ.1) GO TO 620
  TT=TT1+CARM(TI)
  INDEX(I)=1
20 CONTINUE
  WRITE(KW,622) TT1
22 FORMAT(/,10X,'TRAFFIC SWITCHED',5X,FIN,2)
  TCOST1=COST1+CT1*TT1
  TCOST2=COST2+CT1*TT1
  DO 425 I=1,NF
  WRITE(KW,626) I,NI(I),X(I)
25 CONTINUE
  WRITE(KW,135) ITER,TCOST1,TCOST2
  IF(IPBI.EQ.4) GO TO 811
  IF(ITF.GE.3) GO TO 811
  IF(ITER.GT.5) GO TO 811
  IF(ABS(S0(ITER)-S0(ITER-1)).GT.1.) GO TO 666
  CALCULATION OF THE REALIZED GRADE OF SERVICE LEVEL
11 DO 900 I=1,NT
  IN1=IALT(I,1)
  IN2=IALT(I,2)

```

```

BT1=B1 K(I)*BLK(IN1)
BT2=B1 K(I)*BLK(IN2)
GOS(I)=BT1+BT2
WRITE(KW,905) I,GOS(I)
6 CONTINUE
0 SG(ITE)=0.
00 700 K=1,NF
9 INDEX2(K)=0
CALCULATION OF GRADIENTS
00 710 I=1,NT
00 711 K=1,NALT
IJ=I+I*(I,K)
IF(IJ.EQ.0) GO TO 711
IF(INDEX2(IJ).EQ.1) GO TO 711
INDEX2(IJ)=1
NHFE=NT(I,I)+NSF(IJ)
NHF1=NHFE+1
AH=ASTF(IJ)
HF1=ERLANG(NHF1,AH)
HF2=ERLANG(NHF1,AH)
DIF=HF1-HF2
HF=ABS(ASTF(IJ)*HDIF)
WRITE(KW,721) IJ,HF
GRAD(IJ)=C(IJ)*(ASTF(IJ)/HF)
WRITE(KW,707) IJ,GRAD(IJ)
SG(ITE)=SG(ITE)+GRAD(IJ)**2
11 CONTINUE
10 CONTINUE
WRITE(KW,714) (NSF(I),I=NT+1,NF)
WRITE(KW,715) (ASTF(I),I=NT+1,NF)
WRITE(KW,1050) (OFFM(I),I=NT+1,NF)
WRITE(KW,1051) (OFFV(I),I=NT+1,NF)
WRITE(KW,1052) (CARM(I),I=NT+1,NF)
WRITE(KW,1053) (CARV(I),I=NT+1,NF)
SSG(ITE)=SQRT(SG(ITE))
WRITE(KW,624) ITE
24 FORMAT(/,,OVERALL ITERATION NO.,,I3)
WRITE(KW,708) SSG(ITE)
CEKUP=ABS(SSG(ITE-1)-SSG(ITE))
CEK=CEKUP/SSG(ITE)
IF(CEK.LE.0.05) GO TO 555
IF(SSG(ITE).LE.5000.) GO TO 555
IF(ITE.LT.5) GO TO 717
IF((SSG(ITE)-SSG(ITE-1)).GT.0.0) GO TO 555
IF(ITE.EQ.8) GO TO 555
17 CALL MATCO2(NF,NT,NALT,IALT,NAA,GRAD,CFB,BLK,BLOK)
ITE=ITE+1
ITFR=1
IF(IPR1.FQ.5) GO TO 757
00 710 I=NT+13,NAA
OFFM(I)=0.
18 OFFV(I)=0.
OFFM(15)=0.
OFFM(17)=0.
OFFM(18)=0.
OFFM(20)=0.
OFFV(15)=0.
OFFV(17)=0.
OFFV(18)=0.
OFFV(20)=0.

```

```

GO TO 363
IF (IPRI.NE.1) GO TO 8RU
DIMENSIONING STEPS FOR PRIORITY 1
READ(KR,1) (A(IT),IT=1,NT)
READ(KR,35) (C(I),I=1,NT)
ITFR=1
DO 751 IT=1,NT
  BLOK(IT)=0.01
  NS=STN=C
  AST=A(IT)
  BLOKS=BLOK(IT)
  CALL DIM(BLOKS,STN,NS,AST,XI,NII)
35 X(IT)=XI
  NI(IT)=NII
  BLK(IT)=FRLANG(NII,AST)
  IF (BLK(IT).GT.(BLOK(IT)+0.005)) GO TO 1020
GO TO 1021
36 NI=NI+1
  XI=XI+1.
GO TO 1023
21 WRITE(KW,18) IT,ITER,BLK(IT)
31 CONTINUE
  TCOST1=0.
  TCOST2=0.
DO 752 I=1,NT
  TCOST1=TCOST1+C(I)*X(I)
  TCOST2=TCOST2+C(I)*NI(I)
52 CONTINUE
WRITE(KW,135) ITER,TCOST1,TCOST2
GO 1020 I=1,NT
WRITE(KW,626) I,NI(I),X(I)
30 CONTINUE
GO TO 555
80 IF (IPRI.NE.5) GO TO 805
DIMENSIONING STEPS FOR PRIORITY 5
READ(KR,1) (A(IT),IT=1,NT)
READ(KR,2) ((IALT(IT,J),IT=1,NT),J=1,NALT)
READ(KR,35) (C(I),I=1,NAA)
READ(KR,36) CT1,CT2
  IPCHK=0
  CALL PRIOR5(A,IALT,C,CT1,CT2,NA,NAA,NT,NF,NALT,BLOK,ITER,OFFM,OF
  *ITE,KW,NSF,ASTF,BLK,IPCHK)
GO TO 910
57 DO 750 I=NT+13,NAA
  OFFM(I)=0.
  OFFV(I)=0.
58 CONTINUE
  OFFM(15)=0.
  OFFM(17)=0.
  OFFM(18)=0.
  OFFM(20)=0.
  OFFV(15)=0.
  OFFV(17)=0.
  OFFV(18)=0.
  OFFV(20)=0.
  IPCHK=1
  CALL PRIOR5(A,IALT,C,CT1,CT2,NA,NAA,NT,NF,NALT,BLOK,ITER,OFFM,OF
  *ITE,KW,NSF,ASTF,BLK,IPCHK)
GO TO 910
DIMENSIONING STEPS FOR PRIORITY 4

```

```

READ(KR,1) (A(IT),IT=1,NT)
READ(KR,2) ((IALT(IT,J),IT=1,NT),J=1,NALT)
READ(KR,35) (C(I),I=1,NAA)
READ(KR,601) CT1
ITER=1
CSO(ITER)=0.
DO 806 IT=1,NT
DO 807 J=1,2
IN=IAI I(IT,J)
RETA(IN)=0.8
BLK(IN)=0.01
CONTINUE
ITER=ITER+1
DO 808 I=1,NAA
OFFM(I)=0.
OFFV(I)=0.
DO 809 IT=1,NT
NS,STN=0
AST=A(IT)
BLOKS=0.2
I1=IAI I(IT,1)
CALL DIM(BLOKS,STN,NS,AST,XI,NI)
X(IT)=XI
NI(IT)=NT I
AT=A(IT)
CALL OVERFL(AT,XI,NI,OVMP,OVVP,ER)
BLK(IT)=ER
IF(BLK(IT).GT.(BLOKS+0.01)) GO TO 789
GO TO 787
NI=NI I+1
XI=XI+1.
GO TO 789
WRITE(KW,18) IT,ITER,BLK(IT)
OVMP(I1,IT)=OVMP
OVVP(I1,IT)=OVVP
OFFM(I1)=OFFM(I1)+OVMP(I1,IT)
OFFV(I1)=OFFV(I1)+OVVP(I1,IT)
CONTINUE
GO TO 810
STOP
END

```

```

C11D
CURRENT TIME BETAP(31,OM,NB,NIB,AB,RET, BETAB)
A=BET
A=4.
IJ=0. n
CTFP=n.04
IS1,IS2=n
RHSV=n.
KW=6
NB1=NR+NTB
EF=ERI ANG(NB1,AB)
RHSF=(AB/OM)*EF
ITERB=0
RET=BETI-STEP
20 RET=BET+STEP
ITERB=ITERB+1
VB=01*(OM+BET)
ABN=VR+3*01*(01-1.)
NR2=NR1+1
EV=ERI ANG(NB2,ABN)
DIF=ARS((BET-STEP)-RHSV)
RHSV=(ARN*EV)/RHSF-OM
IF(ABS(BET-RHSV).LT.0.01) GO TO 201
IF(BET.GT.RHSV) IS1=1
IF(RHSV.GT.BET) IS2=1
IF((IS1+IS2).EQ.2) GO TO 210
IF(BET.GF.A.AND.BET.LF.B) GO TO 200
IF(IJ.EQ.1) GO TO 240
IF(B.I.E.BET) GO TO 260
GO TO 211
20 IF(ABS(BET-RHSV).LE.DIF) GO TO 280
21 A=A
A=0
RET=B+STFP
STEP=STEP
IJ=1
GO TO 200
210 IF(STEP.I.T.0.) GO TO 220
B=BET
A=BET-STEP
STEP=STEP/10
RET=A-STEP
IS1,IS2=n
GO TO 200
220 A=BET
B=BET-STEP
STEP=STEP/10.
RET=B-STEP
IS1,IS2=n
GO TO 200
240 RET=0.02
201 BETAB=BET
WRITE(KW,203) ITERB
203 FORMAT(7,10X,THE NUMBER OF ITERATIONS TO OBTAIN THE UPDATED BE
*A VALUE IS,,I4)
RETURN
280 RET=B
GO TO 201
END

```

```

RP
FUNCTION CARP(A,N)
  CARP=1.0
  IF(N.FQ.0) GO TO 11
  CARP=A
  IF(N.FQ.1) GO TO 11
  DO 10 I=2,N
10 CARP=CARP*(A/I)
  RETURN
END

```

```

ARRY
SUBROUTINE CARRY(AC,BI,NC,NIC,CM,CV)
  CM=AC*(1.-BL)
  NC1=NC+NIC-1
  NC2=NC+NIC
  EC1=ERLANG(NC1,AC)
  EC2=ERLANG(NC2,AC)
  CL=AC*(EC1-EC2)
  IF(CL.LT.0.0.OR.CL.GT.1.0) GO TO 1
  CV=CM*(1.-CL)
  RETURN
1 CV=CM
  RETURN
END

```

..DIM

```
SUBROUTINE DIM(BLINK,STND,NSD,AD,XD,N,D)
  GO 400 NM=0,100
  ND1=NSD+NM+1
  ND2=NSD+NM
  ED1=ERLANG(ND1,AD)
  ED2=ERLANG(ND2,AD)
  XX=(BLINK-N*ED2+N*ED1)/(ED1-ED2)
  NX=XX
  NN=NX-NSD
  IF(NM.LT.0) GO TO 401
  IF(NM.EQ.NM) GO TO 401
  XD=XX-STND
  NX=XD+n.5
  IF(NLX.EQ.NM) GO TO 401
  LX=XD-n.5
  IF(NLX.EQ.NM) GO TO 401
  IF(ED1.GT.ED2) GO TO 405
400 CONTINUE
401 XD=XX-STND
  IF(XD.LT.0.)XD=0
  IN=XD+0.5
  RETURN
405 ND1=NSD+NM
  ND2=NSD+NM-1
  ED1=ERLANG(ND1,AD)
  ED2=ERLANG(ND2,AD)
  XX=(BLINK-N*ED2+N*ED1)/(ED1-ED2)
  XD=XX-STND
  IN=XD+0.5
  RETURN
END
```

.DIMENS

```

SUBROUTINE DIMENS(HT,AS,NST,STNS,XS,N,S)
  DO 500 N=0,100
    XN=NST+N
    N1=NST+N+1
    N2=NST+N+2
    ES=ER, ANG(XN,AS)
    ES1=ERLANG(N1,AS)
    ES2=ERLANG(N2,AS)
    ES=2*ES1-ES-ES2
    X=((HT/AS)-N1*ES+KN*ES1+N2*ES1-N1*ES2+ES2-ES1)/DS
    VX=X
    NN=NX-NST
    IF(NN.LT.0) GO TO 501
    IF(NN.EQ.N) GO TO 501
    XS=X-STNS
    VNX=XyS+n.5
    IF(NNX.EQ.0) GO TO 501
    NLX=XyS-n.5
    IF(NLX.EQ.0) GO TO 501
    IF(ES1.GT.ES) GO TO 505
500 CONTINUE
501 XS=X-STNS
    IF(XS.LT.0.)XS=0
    VIS=Xs+0.5
    RETURN
505 N=NST+N-1
    N1=NST+N
    N2=NST+N+1
    ES=ER, ANG(XN,AS)
    ES1=ERLANG(N1,AS)
    ES2=ERLANG(N2,AS)
    ES=2*ES1-ES-ES2
    X=((HT/AS)-N1*ES+KN*ES1+N2*ES1-N1*ES2+ES2-ES1)/DS
    XS=X-STNS
    VIS=Xs+0.5
    RETURN
  END
```

ERLANG

```
FUNCTION ERLANG(L,EA)
  DIV1=CARD(EA,L)
  CUMF=1.
  DO 205 J=1,L
  DIV2=CARD(EA,J)
  IF(L.FO.n)DIV2=0.
  CUMF=CUMF+DIV2
205 CONTINUE
  ERLANG=DIV1/SUMF
  RETURN
END
```

ERT

```
SUBROUTINE ERT(TRFV,TRFM,EQVT,EQVN,NE)
  QO=TRFV/TRFM
  EQVT=TRFV+3*QO*(QO-1.)
  DEN=TRFM+QO
  OVER=TRFM+QO-1.
  EQVN=(DEN/OVER)*EQVT-TRFM-1.
  JEQ=EQVN
  RETURN
END
```

```

SUBROUTINE MATCO2(NF,NT,NALT,TALT,NAA,GRAD,EEB,BLK,BLOK)
DIMENSION IALT(13,3),GRAD(33),BLK(34),BLOK(40)
COMMON/BAL/JKL,L,ISB1,MORP1,IYRM1,IRM1,ISP1,CCOF(40),RHS(30),
*CMS(30,40),TYPEC(30),IND(40),MAX
DO 1 T=1,NF
IND(I)=0
CCOF(T)=0
CONTINUE
DO 25 I=1,NF
DO 26 J=1,NAA
CMS(I,J)=0.
RHS(I)=0.
TYPEC(I)=0.
CONTINUE
DO 2 K=1,NT
DO 3 J=1,NALT
TALT(K,J)
IF(MAX.LT.M) MAX=M
IF(M.EQ.0) GO TO 3
IND(M)=1
CONTINUE
CONTINUE
SPECIFICATION OF OBJ FN COEFFICIENTS
I=0
DO 7 T=1,NAA
IF(IND(I).EQ.1) GO TO 4
GO TO 7
4 I=I+1
CCOF(I)=GRAD(I)
7 CONTINUE
RHS SPECIFICATION
DO 11 I=1,NT
1 RHS(I)=EFB
COEFFICIENT MATRIX SPECIFICATION
DO 12 I=1,NT
DO 13 J=1,NALT
TALT(I,J)
LCO=0
DO 14 JJ=1,K
IF(IND(JJ).EQ.1) LCO=LCO+1
4 CONTINUE
CMS(I,LCO)=BLK(I)
3 CONTINUE
2 CONTINUE
DO 35 I=1,NT
5 TYPEC(I)=1
IK=NT+1
JKL=IT+L
DO 50 I=IK,JKL
RHS(I)=0.001
TYPEC(I)=-1
CMS(I,I-NT)=1.
CONTINUE
MORP1=2
IYRM1=100
IRM1=50
ISP1=0
ISB1=-1
PRINT*,NT,NF,JKL,L,JKL,NT,NF,JKL,L,JKL

```

```
PRINT*, ((CMS(I,J), J=1,5), I=1,9)
CALL INP
DO 60 I=1,MAX
IF(INP(I).NE.1) GO TO 60
BLK(I)=CCOF(I)
60 CONTINUE
PRINT*, MAXMAX, MAX, (BLK(I), I=1,MAX)
PRINT*, BLK, (BLK(I), I=1,9)
RETURN
END
```

```

03
SUBROUTINE MATCO3(NF,NT,NL,IFIN,GRAD,EFB,RLK,IALT,NALT,NAA,BLOK)
DIMENSION IFIN(13,3),GRAD(33),BLK(34),IALT(13,3),BLOK(40)
COMMON/BAL/JKL,L,ISRI,MORP1,ITRM1,IRM,ISP1,CCOF(40),RHS(30),
*CMS(30,40),TYPEC(30),IND(40),MAX
DO 1 I=1,NF
IND(I)=0
CCOF(I)=0.
1 CONTINUE
DO 25 I=1,NF
DO 26 J=1,NAA
5 CMS(I,J)=0.
RHS(I)=0.
TYPEC(I)=0.
5 CONTINUE
DO 2 K=1,NT
DO 3 J=1,NL
U=IFIN(K,J)
IF(MAX+LT-M)MAX=M
IF(M.F0.n) GO TO 3
IND(M)=1
3 CONTINUE
2 CONTINUE
081 FH COEFFICIENTS SPECIFICATION
I=0
DO 10 I=1,NF
IF(IND(I).EQ.1) GO TO 20
DO TO 10
20 I=I+1
CCOF(I)=GRAD(I)
10 CONTINUE
RHS SPECIFICATION
DO 11 I=1,NT
11 RHS(I)=EFB
COEFFICIENT MATRIX SPECIFICATION
DO 12 J=1,NL
DO 100 I=1,NT
K=IFIN(I,J)
LC0=0
IF(K.F0.n) GO TO 100
DO 30 JJ=1,K
IF(IND(JJ).EQ.1) LC0=LC0+1
30 CONTINUE
IF(J.NE.1) GO TO 40
CMS(I,LC0)=BLK(I)
DO TO 100
40 CMS(I,LC0)=BLK(I)+BLK(IALT(I,NALT))
10 CONTINUE
12 CONTINUE
DO 35 I=1,NT
35 TYPEC(I)=1
K=NT+1
KI=NT+L
DO 50 I=K,JKL
RHS(I)=0.001
TYPEC(I)=-1
CMS(I,I-NT)=1.
50 CONTINUE
MORP1=2
ITRM1=100

```

```

IRMI=50
ISPI=0
ISRI=-1
PRINT*,INT,NF,JK,L,JKL,INT,NF,JK,L,JKI
PRINT*,((CMS(I,J),J=1,6),I=1,10)
CALL INP
DO 60 I=1,MAX
IF (INT(I).NE.1)GOTO 60
BLK(I)=CCOF(I)
60 CONTINUE
PRINT*,MAXMAX,MAX,(BLK(I),I=1,MAX)
PRINT*,BLK,(BLK(I),I=1,13)
RETURN
END

```

GAMAUP

```
CURROUTINE GAMAUP(AG,NG,NIG,G,I)  
NG1=NG+NTG  
AG1=AG+1.  
EG1=ERLANG(NG1,AG1)  
EG2=ERLANG(NG1,AG)  
IP=AG1*EG1-AG*EG2  
EG3=ERLANG(NIG,AG1)  
EG4=ERLANG(NIG,AG)  
DOWN=AG1*EG3-AG*EG4  
QU=UP/DOWN  
RETURN  
END
```

OVERFL

```
CURROUTINE OVERFL(AO,XO,NFO,QVM,QVV,En)  
EO=ERLANG(NFO,AO)  
QVM=AO*En  
E0F=EO/(NFO+1.0+QVM-AO)  
QVV=QVM*(1.0-QVM+E0F)  
RETURN  
END
```

```

5
SUBROUTINE PRIOR5(A,IALT,C,CT1,CT2,NA,NAA,NT,NF,NALT,BLOK,ITER,OFFV,ITE,KW,NSF,ASTE,BLK,LPCCHK)
DIMENSION A(13),IALT(13,3),C(33),BETA(33),BLOK(40)
DIMENSION OFFM(33),OFFV(33),CD(30),OFFMP(33,33),OFFVP(33,33)
DIMENSION OVMP(33,33),OVVP(33,33),CONCM(32,33),CONSV(32,33),INDEX
(33),Q(33),X(33),BLK(34),GOS(13),ASTE(23),NSF(33)
DIMENSION NI(33),CARM(33),CARV(33),INDEX2(33),SSO(25),SUMSO(25)
IF(LPCCHK.EQ.1) GO TO 551
ITER=1
SSO(ITER)=0
DO 402 IT=1,NT
DO 403 J=1,NALT
TNE=IAI T(IT,J)
BETA(IT,NI)=0.8
BLOK(IT,NI)=0.01
CONTINUE
ITER=ITER+1
DO 405 I=1,NAA
OFFM(IT)=0.
OFFV(IT)=0.
CALCULATION OF THE MARGINAL CAPACITY PARAMETER
DO 406 IT=1,NT
T1=IAI T(IT,1)
T2=IAI T(IT,2)
T3=IAI T(IT,3)
TERM1=C(IT1)/BETA(IT1)
TERM2=C(IT2)/BETA(IT2)
TERM3=C(IT3)/BETA(IT3)
FD(IT)=TERM1+TERM2+TERM3+CT1+CT2
HIT=C(IT)/CD(IT)
WRITE(KW,10) IT,HIT
FORMAT(/,10X,,THE MARGINAL CAPACITY OF LINK,,2X,I3,3X,F5.2)
IF(HIT.EQ.0.) GO TO 403
IF(HIT.LT.1.) GO TO 407
NI(IT)=0
WRITE(KW,11) IT,ITER
FORMAT(/,10X,,LINK,,2X,I3,2X,,SHOULD NOT BE CONSTRUCTED AT ITERA
*TION,,I2)
BLK(IT)=1.
WRITE(KW,12) IT,ITER,BLK(IT)
FORMAT(/,10X,,THE FINAL LINK,,2X,I3,2X,,BLOCKING AT ITERATION,,2
*X,I3,5X,F7.5)
OFFMP(I1,IT)=A(IT)
OFFVP(I1,IT)=A(IT)
OFFM(IT1)=OFFM(I1)+OFFMP(I1,IT)
OFFV(IT1)=OFFV(I1)+OFFVP(I1,IT)
OVMP(I1,IT)=OFFMP(I1,IT)
OVVP(I1,IT)=OFFVP(I1,IT)
GO TO 406
7 AT=A(IT)
NS,STN=0
CALL DIMENS(HIT,AT,NS,STN,XI,NI)
X(IT)=XI
NI(IT)=NI I
CALL OVERFL(AT,XI,NI,OVMP,OVVP,ER)
BLK(IT)=FR
WRITE(KW,13) IT,ITER,BLK(IT)
OVMP(I1,IT)=OVMP
OVVP(I1,IT)=OVVP

```

```

OFFM(I1)=OFFM(I1)+OVMP(I1,IT)
OFFV(I1)=OFFV(I1)+OVVP(I1,IT)
CONTINUE
DO 515 K=1,NA
INDEX(K)=0
IJ=1
DO 516 IT=1,NT
I1=IAI T(I,T,JJ)
IF(INDEX(I1).EQ.1) GO TO 516
O(I1)=OFFV(I1)/OFFM(I1)
WRITE(KW,13) I1,ITER,O(I1)
FORMAT(7,10X,0(,13,)) AT ITERATION,13,2X,F5.3)
OFFVS=OFFV(I1)
OFFMS=OFFM(I1)
IF(O(I1).LE.1.) GO TO 501
CALL FRT(OFFVS,OFFMS,AST,STN,NS)
ASTF(I1)=AST
NSF(I1)=NS
GO TO 502
1 NS,STN=O
ST=OFFM(I1)
ASTF(I1)=AST
NSF(I1)=NS
O(I1)=1.
2 BLOKS=BLK(I1)
CALL NIM(BLOKS,STN,NS,AST,XI,NII)
2 X(I1)=XI
NI(I1)=NII
VFF=NS+NI
RLK(I1)=FRLANG(NFE,AST)
IF(BLK(I1).GT.(BLOK(I1)+0.005)) GO TO 2000
GO TO 2001
00 NII=NI I+1
XI=XI+1.
GO TO 2002
01 IF(NIT.EQ.0) NII=1
OS=O(I1)
RETT=RETA(I1)
CALL RETUP(OS,OFFMS,NS,NII,AST,BETT,RETAS)
RETA(I1)=BETAS
WRITE(KW,14) I1,ITER,BETAS
FORMAT(7,10X,BETA(,13,)) AT ITERATION,13,2X,F5.3)
BLOKS=BLK(I1)
CALL CARRY(AST,BLOKS,NS,NII,CARMS,CARV,S)
CARM(I1)=CARMS
CARV(I1)=CARVS
WRITE(KW,12) I1,ITER,RLK(I1)
INDEX(I1)=1
16 CONTINUE
IF(JJ.EQ.2) GO TO 521
DO 517 K=1,NA
INDEX(K)=0
DO 518 I=1,NT
I1=IAI T(I,2)
I1=IAI T(I,1)
IF(INDEX(I1).EQ.1) GO TO 518
OFFM(I1)=OFFM(I1)+CARM(I1)
OFFV(I1)=OFFV(I1)+CARV(I1)
INDEX(I1)=1
18 CONTINUE

```

```

70 510 K=1, NAA
INDEX(K)=0
IJ=2
GO TO 520
EIGHT FACTOR CALCULATION
SUMM=0.
SUMV=0.
70 525 K=1, NT
INDEX(K)=0
70 522 I=1, NT
I1=IA1 I(I,1)
SUMM=SUMM+OVMP(I1,I)
SUMV=SUMV+OVVP(I1,I)
CONTINUE
70 523 I=1, NT
IF(INDEX(I).EQ.1) GO TO 523
SUMM=0.
SUMV=0.
I3=IA1 I(I,3)
I2=IA1 I(I,2)
70 524 J=1, NT
IF(I3.NE.IALT(J,3)) GO TO 524
I1=IA1 I(I,1)
INDEX(J)=1
SUMM=SUMM+OVMP(I1,J)
SUMV=SUMV+OVVP(I1,J)
CONSM(I2,I3)=SUMM/SUMM
CONSV(I2,I3)=SUMV/SUMV
CONTINUE
OFFM(I3)=CONSM(I2,I3)*CARM(I2)
OFFV(I3)=CONSV(I2,I3)*CARV(I2)
O(I3)=OFFV(I3)/OFFM(I3)
WRITE(KV,I3) I3,ITER,O(I3)
OFFVS=OFFV(I3)
OFFMS=OFFM(I3)
IF(O(I3).LE.1.) GO TO 1101
CALL FRT(OFFVS,OFFMS,AST,STN,NS)
AST(I3)=AST
NS(I3)=NS
GO TO 1102
1 NS,STI=0
AST=OFFM(I3)
ASTF(I3)=AST
NSF(I3)=NS
O(I3)=1.
2 BLOKS=BLOK(I3)
CALL DIM(BLOKS,STN,NS,AST,XI,NI)
5 X(I3)=XI
NI(I3)=NTI
JF=NC+NTI
BLK(I3)=ERLANG(NFE,AST)
IF(BLK(I3).GT.(BLOK(I3)+0.005)) GO TO 2003
GO TO 2004
3 NIT=NTI+1
XI=XI+1.
GO TO 2005
4 IF(NIT.EQ.0) NII=1
AS=O(I3)
BETT=BETA(I3)
CALL BETADP(OS,OFFMS,NS,NTI,AST,BETT,DETAS)

```

```

BETA(13)=BETAS
WRITE(KW,14) I3,ITER,BETAS
ALOKS=BLK(13)
WRITE(KW,12) I3,ITER,ALK(I3)
CONTINUE
SUMSQ(ITER)=0.
DO 526 M=1,NF
SUMSQ(ITER)=SUMSQ(ITER)+X(M)**2
SSQ(ITER)=SQRT(SUMSQ(ITER))
COST1=0.
COST2=0.
DO 527 I=1,NF
COST1=COST1+C(I)*X(I)
COST2=COST2+C(I)*NI(I)
CONTINUE
DO 528 K=1,NA
INDEX(K)=0
CALCULATION OF TRAFFIC PASSING THROUGH THE TANDEM SWITCH
TT1=0.
TT2=0.
DO 529 I=1,NT
TI=IAI T(I,1)
K2=IAI T(I,2)
IF(INDEX(I1).EQ.1) GO TO 530
TT1=TT1+CARM(I1)
INDEX(I1)=1
IF(INDEX(K2).EQ.1) GO TO 529
TT2=TT2+CARM(K2)
INDEX(K2)=1
CONTINUE
WRITE(KW,15) TT1,TT2
FORMAT(/,10X, TRAFFIC SWITCHED BY THE TWO TANDEMS ARE, 3X,F10.2,
*2X,F10.2)
TCOST1=COST1+CT1*TT1+CT2*TT2
TCOST2=COST2+CT1*TT1+CT2*TT2
DO 531 I=1,NF
WRITE(KW,26) I,NI(I),X(I)
CONTINUE
6 FORMAT(/,5X, NI AND XI FOR LINK, 2X, I,3,3X, I3,2X, F5.2)
WRITE(KW,27) ITER,TCOST1,TCOST2
7 FORMAT(/,10X, THE ITERATION NUMBER FOR STABILIZATION, 15, THE
TOTAL NETWORK COSTS ARE, 5X, F15.1,2X, F15.1)
IF(ITER.GE.3) GO TO 540
IF(ITER.GT.5) GO TO 540
IF(ABS(SSQ(ITER)-SSQ(ITER-1)).GT.1.) GO TO 777
CALCULATION OF THE REALIZED GRADE OF SERVICE LEVEL
0 DO 541 I=1,NT
IN1=IALT(I,1)
IN2=IALT(I,2)
IN3=IALT(I,3)
BT1=BLK(I)*BLK(IN1)
BT2=BLK(I)*BLK(IN2)
BT3=BLK(I)*BLK(IN3)
GOS(I)=BT1+BT2+BT3
WRITE(KW,28) I,GOS(I)
8 FORMAT(/,5X, GOS FOR RELATION, 2X, I,2,2X, F5.3)
CONTINUE
RETURN
END

```