

EVALUATION OF DEFORMATION CAPACITY CRITERIA OF
EUROCODE 8

by

A.Koray ÖZAL

B.S., Civil Engineering, Middle East Technical University, 2005

Submitted to the Kandilli Observatory and Earthquake Research Institute
for Graduate Studies in Earthquake Engineering in partial fulfillment of
the requirements for degree of
Master of Science

Graduate Program in Earthquake Engineering

Boğaziçi University

2008

To my family;

ACKNOWLEDGEMENTS

I want to express my deepest gratitude to Prof. Dr. M.Nuray Aydınoglu for his guidance, advice, motivation, criticism, encouragements in the scope of this research. I would never able to finish this thesis without his valuable suggestions.

I want to express special thanks to my colleague Özgür Özçıtak for his help and invaluable support when I come across any kind of difficulties during my thesis study.

I want to thank to Levent Özden, Aysun Günay and Ercan Yılmaz for his courage and patience during my graduate period and sharing his invaluable experience in civil engineering.

My parents Celal Özal, Nuran Özal and my brother Aytuğ Özal are always supported me and never left me alone in my life.

Finally, I am grateful to all instructors and assistants of Boğaziçi University, Kandilli Observatory and Earthquake Research Institute, Department of Earthquake Engineering for their valuable contributions to my academic knowledge.

ABSTRACT

EVALUATION OF DEFORMATION CAPACITY CRITERIA OF EUROCODE 8

Deformation capacity criteria of structures that are under earthquake effect could be obtained from various world-wide used seismic codes. Eurocode8 (2005), FEMA356 (2000) and Turkish seismic code (2007) are three of seismic code compared in this study. Eurocode8 (2005) which is the basis of this study, recommends calculating deformation capacity of beams, columns, and walls by empirical chord rotation expressions at Part 3 (Assessment and Retrofitting of buildings). Moreover Eurocode8 (2005) proposes that under restrictive conditions the chord rotation demands could be estimated from linear static or linear modal spectrum analysis if important-significant irregularities do not exist. In this study empirical plastic chord rotations wanted to be validated by comparing them with other seismic codes limitations and tried to be observed for different parameters effect on chord rotation demands of simple, regular rectangular column sections.

ÖZET

EUROCODE8'DEKİ DEFORMASYON KAPASİTE KRİTERLERİNİN DEĞERLENDİRİLMESİ

Deprem etkisi altındaki yapıların deformasyon kapasite kriterleri dünyaca kullanılan deprem yönetmeliklerinde farklılıklar göstermektedir. Bu çalışmada Eurocode8 (2005), FEMA356 (2000) ve Deprem Yönetmeliği (2007) karşılaştırılmıştır. Bu çalışmanın asıl amacı olan Eurocode8 (2000), kolon, kiriş perde gibi elemanların deformasyon kapasite kriterleri bulunurken Bölüm 3'te (Yapıların Değerlendirilmesi ve Güçlendirilmesi) bulunan ampirik formüllerin kullanılmasını öneriyor. Aynı zamanda Eurocode8 (2005) önemli yapısal düzensizliği bulunmayan yapılarda lineer static veya modal spectral analizler sayesinde deformasyon kapasite kriterleri elde edilebileceğini belirtiyor. Bu çalışmada Eurocode8 (2005) deki ampirik bağıntılar diğer deprem yönetmeliklerindeki kriterlerle karşılaştırılmıştır, ayrıca basit- diktörgen kolonlarda farklı parametrelerin dönme kapasitesi hesaplarındaki etkileri gözlenmiştir.

TABLE OF CONTENTS

ACKNOWLEDGEMENTS.....	iv
ABSTRACT.....	v
ÖZET.....	vi
1. INTRODUCTION.....	1
2. CALCULATION OF CHORD ROTATION AT EUROCODE 8.....	4
2.1. Calculation of Plastic Chord Rotation.....	4
2.1.1. Investigation of the Terms in the Plastic Chord Rotation Formula (2.1).....	6
2.2. Calculation of Total Chord Rotation.....	7
3. COMPLIANCE CRITERIA FOR CONCRETE BUILDINGS.....	8
3.1. Methodology of Seismic Codes.....	8
3.1.1. Fema FEMA356 (2000).....	9
3.1.2. Eurocode 8 part 3 EN1998-3 (2005).....	10
3.1.3. Turkish Seismic Code TSC (2007).....	11
3.2. Different Section Dimensions Effect on Compliance Criterion.....	13
3.2.1. f_{ck} (20Mpa), f_{yk} (420Mpa), %2, Unconfined.....	14
3.2.2. f_{ck} (20Mpa), f_{yk} (220Mpa), %2, Confined.....	17
3.3. Effect of Different Confinement Properties on Compliance Criterion.....	20
3.3.1. 50x50, f_{ck} (20Mpa), f_{yk} (420Mpa), %2.....	21
3.4. Effect of Different Reinforcement Ratio on Compliance Criterion.....	23
3.4.1. 50x50, f_{ck} (14Mpa), f_{yk} (220Mpa), Unconfined.....	24
3.4.2. 50x50, f_{ck} (20Mpa), f_{yk} (420Mpa), Confined.....	27
3.5. Effect of Different Concrete Strength Levels on Compliance Criterion.....	30
3.5.1. 50x50, f_{yk} (220Mpa), %1, Unconfined.....	30
3.5.2. 50x50, f_{yk} (220Mpa), %1, Confined.....	33
3.6. Effect of Different Steel Strength Classes on Compliance Criterion.....	35
3.6.1. 50x50, f_{ck} (20Mpa),%1, Unconfined.....	35
4. COMPARISON OF TOTAL CHORD ROTATION CALCULATIONS.....	39
4.1. Graphs and Charts.....	40
4.1.1. 40x40, f_{ck} (30Mpa), f_{yk} (420Mpa), 10/10+1 crosstie.....	41
4.1.2. 40x40, f_{ck} (25Mpa), f_{yk} (420Mpa), 10/10+1 crosstie.....	42

4.1.3. 40x40, f_{ck} (20Mpa), f_{yk} (420Mpa), 10/10+1 crosstie	42
4.1.4. 40x40, f_{ck} (15Mpa), f_{yk} (420Mpa), 10/10+1 crosstie	43
4.1.5. 40x40, f_{ck} (15Mpa), f_{yk} (220Mpa), 10/10+1 crosstie	43
4.1.6. 30x40, f_{ck} (15Mpa), f_{yk} (220Mpa), 10/10+1 crosstie	44
4.1.7. 20x40, f_{ck} (30Mpa), f_{yk} (420Mpa), 10/10+1 crosstie	44
4.1.8. 40x30, f_{ck} (30Mpa), f_{yk} (420Mpa), 10/10+1 crosstie	45
4.1.9. 40x20, f_{ck} (30Mpa), f_{yk} (420Mpa), 10/10+1 crosstie	45
4.1.10. 40x40, f_{ck} (30Mpa), f_{yk} (420Mpa), 8/20 crosstie	46
4.1.11. 40x40, f_{ck} (30Mpa), f_{yk} (420Mpa), 8/30 crosstie	46
4.1.12. 40x40, f_{ck} (30Mpa), f_{yk} (420Mpa), 6/30 crosstie	47
5. CONCLUSIONS	48
REFERENCES	49

LIST OF FIGURES

Figure 1.1.	Definition of chord rotation.....	2
Figure 2.1.	Investigation of the terms of plastic chord rotation formula	7
Figure 3.1.	Plastic chord rotation vs. axial force ratio curve of Graph no: 1.....	14
Figure 3.2.	Plastic chord rotation vs. axial force ratio curve of Graph no: 2.....	15
Figure 3.3.	Plastic chord rotation vs. axial force ratio curve of Graph no: 3.....	16
Figure 3.4.	Plastic chord rotation vs. axial force ratio curve of Graph no: 4.....	17
Figure 3.5.	Plastic chord rotation vs. axial force ratio curve of Graph no: 5.....	18
Figure 3.6.	Plastic chord rotation vs. axial force ratio curve of Graph no: 6.....	19
Figure 3.7.	Plastic chord rotation vs. axial force ratio curve of Graph no: 7.....	21
Figure 3.8.	Plastic chord rotation vs. axial force ratio curve of Graph no: 8.....	22
Figure 3.9.	Plastic chord rotation vs. axial force ratio curve of Graph no: 9.....	23
Figure 3.10.	Plastic chord rotation vs. axial force ratio curve of Graph no: 10.....	24
Figure 3.11.	Plastic chord rotation vs. axial force ratio curve of Graph no: 11.....	25
Figure 3.12.	Plastic chord rotation vs. axial force ratio curve of Graph no: 12.....	26
Figure 3.13.	Plastic chord rotation vs. axial force ratio curve of Graph no: 13.....	27
Figure 3.14.	Plastic chord rotation vs. axial force ratio curve of Graph no: 14.....	28
Figure 3.15.	Plastic chord rotation vs. axial force ratio curve of Graph no: 15.....	29
Figure 3.16.	Plastic chord rotation vs. axial force ratio curve of Graph no: 16.....	30
Figure 3.17.	Plastic chord rotation vs. axial force ratio curve of Graph no: 17.....	31
Figure 3.18.	Plastic chord rotation vs. axial force ratio curve of Graph no: 18.....	32
Figure 3.19.	Plastic chord rotation vs. axial force ratio curve of Graph no: 19.....	33
Figure 3.20.	Plastic chord rotation vs. axial force ratio curve of Graph no: 20.....	34
Figure 3.21.	Plastic chord rotation vs. axial force ratio curve of Graph no: 21.....	35
Figure 3.22.	Plastic chord rotation vs. axial force ratio curve of Graph no: 22.....	36
Figure 3.23.	Plastic chord rotation vs. axial force ratio curve of Graph no: 23.....	37
Figure 3.24.	Plastic chord rotation vs. axial force ratio curve of Graph no: 24.....	38
Figure 4.1.	Chord rotation vs. axial force ratio curves of Model 1.....	41
Figure 4.2.	Chord rotation vs. axial force ratio curves of Model 2.....	42
Figure 4.3.	Chord rotation vs. axial force ratio curves of Model 3.....	42
Figure 4.4.	Chord rotation vs. axial force ratio curves of Model 4.....	43

Figure 4.5. Chord rotation vs. axial force ratio curves of Model 5.....	43
Figure 4.6. Chord rotation vs. axial force ratio curves of Model 6.....	44
Figure 4.7. Chord rotation vs. axial force ratio curves of Model 7.....	44
Figure 4.8. Chord rotation vs. axial force ratio curves of Model 8.....	45
Figure 4.9. Chord rotation vs. axial force ratio curves of Model 9.....	45
Figure 4.10. Chord rotation vs. axial force ratio curves of Model 10.....	46
Figure 4.11. Chord rotation vs. axial force ratio curves of Model 11.....	46
Figure 4.12. Chord rotation vs. axial force ratio curve of Model 12	47

LIST OF TABLES

Table 3.1. FEMA356 Modeling parameters and numerical acceptance criteria for nonlinear procedures-reinforced concrete columns	9
Table 3.2. Compliance Criteria for assessment or retrofitting of concrete members	10
Table 3.3. Compliance Criteria for assessment or retrofitting of concrete members (<i>Plastic chord rotation limitations</i>)	10
Table 3.4. Strain capacities of reinforced concrete sections at (7.6.9.2) in TSC (2007) ...	11
Table 3.5. Models that are used	12
Table 4.1. Models that are used	40

LIST OF SYMBOLS / ABBREVIATIONS

θ_E	Chord-rotation demand from the analysis
L_v	M/V , ratio moment/shear (shear span) at the end section
θ_y	chord-rotation at yielding
$\theta_{u,m-\sigma}$	mean-minus-standard deviation chord-rotation supply
θ_{um}	mean chord-rotation supply
α_{Vz}	tension shift of the bending moment diagram
α_v	if shear cracking precedes flexural yielding at the end section (i.e. when the yield moment at the end section, M_y , exceeds the product of L_s and of the shear resistance without shear reinforcement, $V_{R,c}$, according to Eurocode 2); otherwise, (i.e. if $M_y < L_s V_{R,c}$) $\alpha_v=0$
z	length of internal lever arm, taken equal to the distance of the tension to the compression reinforcement, $z = d-d_1$, in beams, columns, or walls with barbelled or T-section, or to $z = 0.8h$ in walls with rectangular section
h :	section depth
f_y	steel yield stress, in MPa
f_c	concrete strength, in MPa
d_{bL}	(mean) diameter of tension reinforcement;
ν	N/bhf_c , (axial force ratio)
b	width of the compression zone
N	axial force, positive for compression
ω_1, ω_2	mechanical reinforcement ratio of the tension (including the web reinforcement) and of the compression, respectively
f_{yw}	yield stress of transverse reinforcement, in MPa
ρ_{sx}	$A_{sx}/b_w s_h$, ratio of transverse reinforcement parallel to the direction x of loading
s_h	stirrup spacing
ρ_d	steel ratio of (any) diagonal reinforcement in each diagonal direction
α	confinement effectiveness factor
b_o, h_o	dimensions of confined core to the centerline of the hoop
b_i	centerline spacing of longitudinal bars (indexed by i) laterally restrained by stirrup corner or a cross-tie along the perimeter of the cross-section

1. INTRODUCTION

Several methods and criteria are being using recently in evaluation and determination of the deformations occurred in structural elements of a structure. Deformation capacity criteria of structures that are under earthquake effect could be obtained from various world-wide used seismic codes. Eurocode8 (EN1998-3,2005), FEMA356 (FEMA356,2000) and Turkish seismic code (TSC,2007) are three of seismic code used in this study. Eurocode8 which is the basis of this study, recommends calculating deformation capacity of beams, columns, and walls by empirical chord rotation expressions at Part 3 (Assessment and Retrofitting of buildings). Moreover Eurocode8 (EN1998-3,2005) proposes that under restrictive conditions the chord rotation demands could be estimated from linear static or linear modal spectrum analysis if important- significant irregularities does not exist.

Chord rotation is used to define the deformation capacity of beams, columns and walls. According to EN1998-3 (2005) chord rotation is the angle between the tangent to the axis at the yielding end and the chord rotating at that end with the end of shear span ($L_v = M/V = \text{moment /shear at the end section}$), that is the point of contraflexure. Another alternative definition of chord rotation is equal to the element drift ratio, the deflection at the end of the shear span with respect to the tangent to the axis at the yielding end, divided by the shear span.

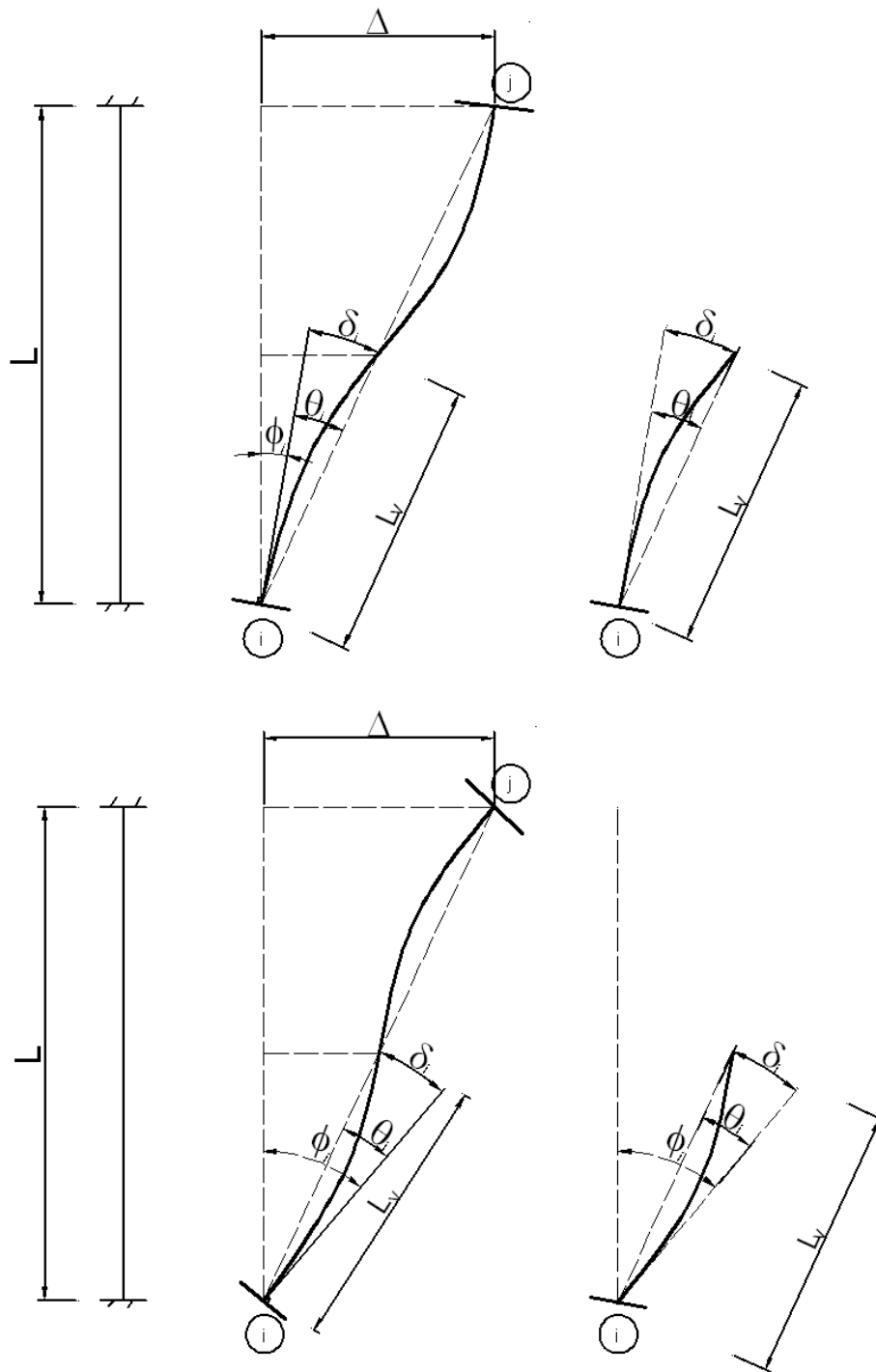

Figure 1.1. Definition of chord rotation

$$\theta_i = \frac{\delta_i}{Lv_i} = \left| \frac{\Delta}{L} - \phi_i \right|$$

(1.1)

At third chapter chord rotations are investigated and different seismic code deformation criteria are plotted on same graph to observe harmony of performance criteria at different earthquake codes such as EN1998-3 (2005), FEMA356 (2000), TSC (2007). At fourth chapter appropriateness of alternative total chord rotation expressions is investigated, i.e. Direct total chord rotation expression and plastic plus yield rotation expressions.

2. CALCULATION OF CHORD ROTATION AT EUROCODE 8

2.1. Calculation of Plastic Chord Rotation

The objective of this part is to calculate the plastic chord rotation versus axial force ratio curves in different methods stated in Eurocode 8 -Design of Structures for earthquake resistances / Part 3: Assessment and Retrofitting of buildings EN1998-3 (2005).

Three methods are suggested for calculation of Plastic chord rotation. First alternative is direct empirical formula whereas other two formulae differ. Second (2.4) and Third (2.5) alternatives are similar but those alternatives suggest different concrete confinement models. Second alternative directly refers to EN1992-1-1 (2004) but third alternative which represents better model as stated as “*a confinement model which represents better than the model in at EN1998-3 (2005)*” suggests another model from EN1992-1-1 (2004) confinement model.

First alternative, direct empirical formula;

$$\theta_{um}^{pl} = \frac{1}{\gamma_{el}} 0.0145 (0.25^v) \left[\frac{\max(0.01: \omega')}{\max(0.01: \omega)} \right]^{0.3} f_c^{0.2} \left(\frac{L_V}{h} \right)^{0.35} 25^{\left(\alpha \rho_{sx} \frac{f_{yw}}{f_c} \right)} (1.275^{100 \rho_d}) \quad (2.1)$$

where:

γ_{el} : is equal to 1.8 for primary seismic elements and 1.0 for secondary seismic elements,

v : N/bhf_c

b : width of the compression zone,

N : axial force, positive for compression,

ω_1, ω_2 : mechanical reinforcement ratio of the tension (including the web reinforcement) and of the compression, respectively, longitudinal reinforcement,

$$\omega_1 = (\rho_1 f_{y1} + \rho_2 f_{yv}) / f_c, \quad \omega_2 = \rho_2 f_{y2} / f_c; \quad (2.2)$$

- f_{yw} : yield stress of transverse reinforcement, in MPa,
 ρ_{sx} : $A_{sx}/b_w s_h$, ratio of transverse reinforcement parallel to the direction x of loading
 s_h : stirrup spacing,
 ρ_d : steel ratio of (any) diagonal reinforcement in each diagonal direction,
 α : Confinement effectiveness factor:

$$\alpha = \left(1 - \frac{s_h}{2b_o}\right) \left(1 - \frac{s_h}{2h_o}\right) \left(1 - \frac{\sum b_i^2}{6h_o b_o}\right) \quad (2.3)$$

- b_o, h_o : dimensions of confined core to the centerline of the hoop,
 b_i : centerline spacing of longitudinal bars (indexed by i) laterally restrained by a stirrup corner or a cross-tie along the perimeter of the cross-section,
 L_s : M/V , ratio moment/shear (shear span) at the end section,
 h : section depth,
 f_y, f_c : steel yield stress and concrete strength, respectively, in MPa, directly obtained as mean values from in-situ test, and from the additional sources of information, appropriately divide by the confidence factors, accounting for the level of knowledge attained,
 d_{bL} : (mean) diameter of tension reinforcement,

Second alternative;

$$\theta_{um} = \frac{1}{\gamma_{el}} \left(\theta_y + (\varphi_u - \varphi_y) L_{pl} \left(1 - \frac{0.5L_{pl}}{L_v}\right) \right), \quad \theta_{pl} = \theta_{um} - \theta_y \quad (2.4)$$

Third alternative;

$$\theta_{um} = \frac{1}{\gamma_{el}} \left(\theta_y + (\varphi_u - \varphi_y) L_{pl} \left(1 - \frac{0.5L_{pl}}{L_v}\right) \right), \quad \theta_{pl} = \theta_{um} - \theta_y \quad (2.5)$$

where:

θ_y : yield chord rotation,

ϕ_u : ultimate curvature,

ϕ_y : yield curvature,

L_{pl} : plastic hinge length;

2.1.1. Investigation of the Terms in the Plastic Chord Rotation Formula (2.1)

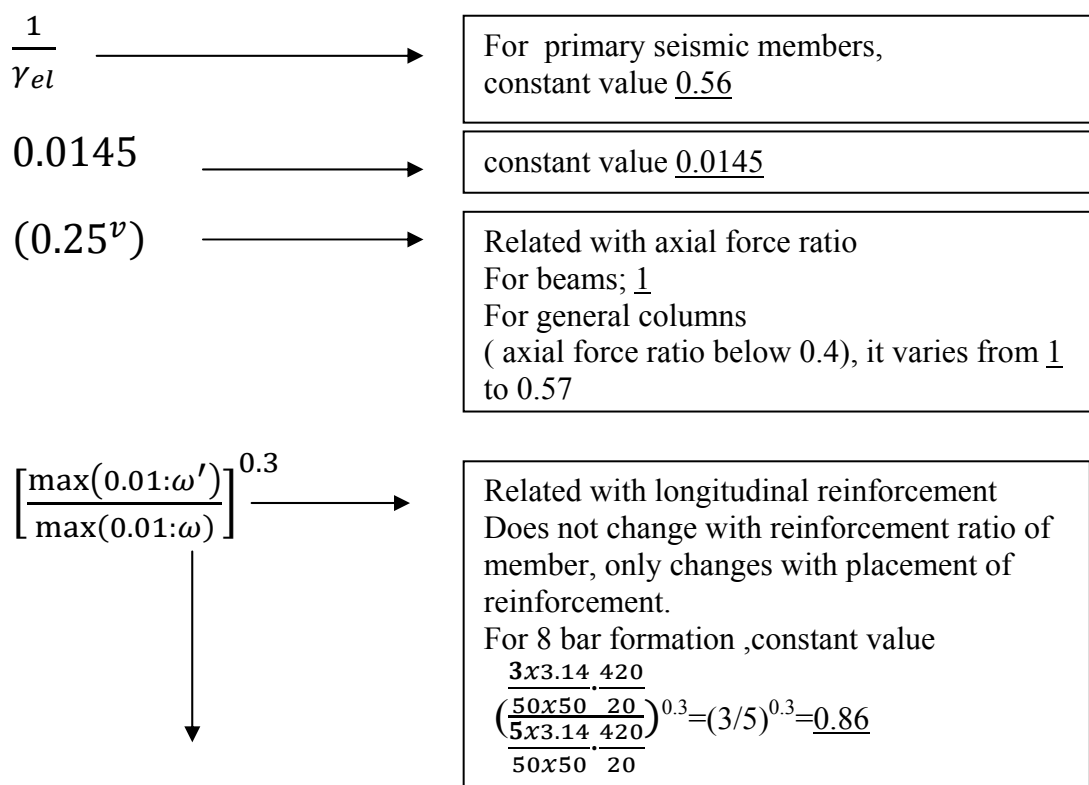

For example; for 50x50 section with 8 ϕ 20
bars $f_c=20\text{MPa}$ and $f_y=420\text{MPa}$

$$\frac{5 \times 3.14 \cdot 420}{50 \times 50} \cdot \frac{420}{20} = 0.13 \gg 0.01$$

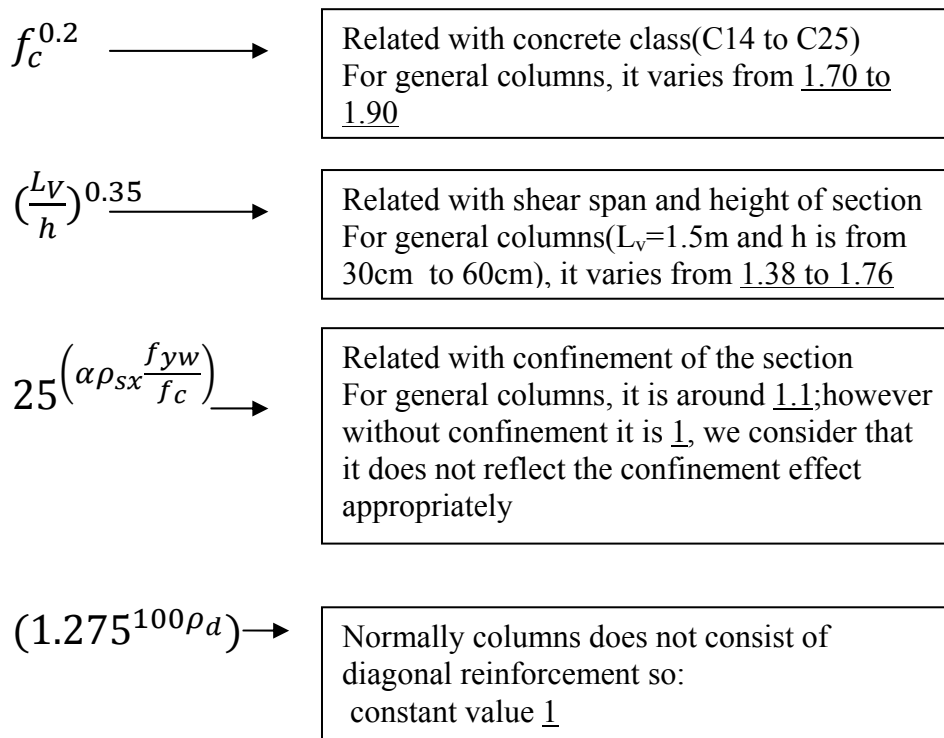

Figure 2.1. Investigation of the terms of plastic chord rotation formula

In members with smooth-plain bars (S220), the plastic part of the chord rotation capacity may be taken to be equal to that calculated accordance with (2.1) multiplied by 0.375.

2.2. Calculation of Total Chord Rotation

$$\theta_{um} = \frac{1}{\gamma_{el}} 0.016(0.3^v) \left[\frac{\max(0.01: \omega')}{\max(0.01: \omega)} \right]^{0.225} f_c^{0.225} \left(\frac{L_V}{h}\right)^{0.35} 25\left(\alpha\rho_{sx}\frac{f_{yw}}{f_c}\right) (1.275^{100\rho_d}) \quad (2.6)$$

Only some of the coefficients are different from plastic chord rotation formula.

3. COMPLIANCE CRITERIA FOR CONCRETE BUILDINGS

Compliance criteria, performance criteria for assessment or retrofitting of concrete members differs in commonly used codes such as FEMA356 (2000), EN1998-3 (2005) and TSC (2007). Performance evaluations are classified according to *plastic rotation* at FEMA356 (2000), according to *total chord rotation* at EN1998-3 (2005) and according to *material strains* at TSC (2007). In this chapter of my study, three different seismic performance criteria are plotted on same graph to observe relation within each other. We have calculated performance evaluation are classified according to *plastic rotation* at FEMA356 (2000) and according to *plastic chord rotation* at EN1998-3 (2005) , however calculations of plastic rotations according to *material strains* at TSC (2007) are obtained from Oğuz Bahadır Şadan thesis submitted to Kandilli Observatory and Earthquake Research Institute Şadan (2005).

3.1. Methodology of Seismic Codes

To plot three different seismic performance criteria on same graph, they must be at converted to same units. Like FEMA356 (2000) , plastic rotation is selected as base unit, other codes will be converted to plastic rotations.

3.1.1. Fema FEMA356 (2000)

Table 3.1. FEMA356 Modeling parameters and numerical acceptance criteria for nonlinear procedures-reinforced concrete columns

Conditions			Modeling Parameters ⁴			Acceptance Criteria ⁴				
			Plastic Rotation Angle, radians		Residual Strength Ratio	Plastic Rotation Angle, radians				
						Performance Level				
			a	b	c	IO	Component Type			
Primary		Secondary								
LS	CP	LS	CP							
i. Columns controlled by flexure¹										
$\frac{P}{A_g f'_c}$	Trans. Reinf. ²	$\frac{V}{b_w d \sqrt{f'_c}}$								
≤ 0.1	C	≤ 3	0.02	0.03	0.2	0.005	0.015	0.02	0.02	0.03
≤ 0.1	C	≥ 6	0.016	0.024	0.2	0.005	0.012	0.016	0.016	0.024
≥ 0.4	C	≤ 3	0.015	0.025	0.2	0.003	0.012	0.015	0.018	0.025
≥ 0.4	C	≥ 6	0.012	0.02	0.2	0.003	0.01	0.012	0.013	0.02
≤ 0.1	NC	≤ 3	0.006	0.015	0.2	0.005	0.005	0.006	0.01	0.015
≤ 0.1	NC	≥ 6	0.005	0.012	0.2	0.005	0.004	0.005	0.008	0.012
≥ 0.4	NC	≤ 3	0.003	0.01	0.2	0.002	0.002	0.003	0.006	0.01
≥ 0.4	NC	≥ 6	0.002	0.008	0.2	0.002	0.002	0.002	0.005	0.008
ii. Columns controlled by shear^{1, 3}										
All cases ⁵			—	—	—	—	—	—	0.0030	0.0040
iii. Columns controlled by inadequate development or splicing along the clear height^{1, 3}										
Hoop spacing ≤ d/2			0.01	0.02	0.4	0.005	0.005	0.01	0.01	0.02
Hoop spacing > d/2			0.0	0.01	0.2	0.0	0.0	0.0	0.005	0.01
iv. Columns with axial loads exceeding 0.70P_o^{1, 3}										
Conforming hoops over the entire length			0.015	0.025	0.02	0.0	0.005	0.01	0.01	0.02
All other cases			0.0	0.0	0.0	0.0	0.0	0.0	0.0	0.0

Table 3.1 is copied from (FEMA356, 2000, s. 6-22). Plastic rotation angles are used from Table 3.1, for interval values of axial force ratio ($\frac{P}{A_g f'_c}$) plastic rotation angles are interpolated. If hoops are spaced at $\leq d/3$, section considered as non confined (NC) section. Shear force ratio ($\frac{V}{b_w d \sqrt{f'_c}}$) is considered below three is tagged with 'FEMA356-V3', whereas shear force ratio greater than six are tagged with 'FEMA356-V6'.

3.1.2. Eurocode 8 part 3 EN1998-3 (2005)

Table 3.2. Compliance Criteria for assessment or retrofitting of concrete members
(Total Chord rotation limitations)

Member	Limited Damage (LD)	Significant Damage (SD)	Near Collapse (NC)	
			Linear analysis	Non-linear analysis
Ductile primary	$\theta_E^{(1)} \leq \theta_y^{(2)}$	$\theta_E^{(1)} \leq 0.75 \theta_{u,m-\sigma}^{(3)}$	$\theta_E^{(1)} \leq \theta_{u,m-\sigma}^{(3)}$	
Ductile secondary		$\theta_E^{(1)} \leq 0.75 \theta_{u,m}^{(4)}$	$\theta_E^{(1)} \leq \theta_{um}^{(4)}$	

Table 3.2. is copied from FARDIS (2007) which is tabulated form of criteria of EN1998-3 (2005)

Where;

- (1) θ_E : chord-rotation demand from the analysis.
- (2) θ_y : chord-rotation at yielding, Equation (4.2)
- (3) $\theta_{u,m-\sigma}$: mean-minus-standard deviation chord-rotation supply, e.g., $\theta_{u,m-\sigma} = \theta_y + \theta_{um}^l / 1.8$, with θ_y from Equation (4.2) and θ_{um}^l from (2.1).
- (4) θ_{um} : mean chord-rotation supply, from Equation (2.6) or $\theta_{um} = \theta_y + \theta_{um}^l$ with θ_y and $\theta_{u,m}^l$ according to (2.1)

However, all above criteria is for total chord rotation, so yield chord rotation is subtracted from total chord rotation to form plastic chord rotation performance limitations. “*Limited Damage*” corresponds to “*Immediate Occupancy*” performance level, “*Significant Damage*” corresponds to “*Life Safety*” performance level and “*Near Collapse*” corresponds to “*Collapse prevention*” performance level.

Table 3.3. Compliance Criteria for assessment or retrofitting of concrete members
(Plastic chord rotation limitations)

Member	Limited Damage (LD)	Significant Damage (SD)	Near Collapse (NC)	
			Linear analysis	Non-linear analysis
Ductile primary	$\theta_E^{pl} \leq 0$	$\theta_E^{pl} \leq 0.75 \theta_{um}^{pl}$	$\theta_E^{pl} \leq \theta_{um}^{pl}$	
Ductile secondary				

3.1.3. Turkish Seismic Code (TSC, 2007)

Turkish seismic code uses strain based evaluation while investigating performance criteria of the section.

Table 3.4. Strain capacities of reinforced concrete sections at (7.6.9.2) in TSC (2007)

	MN	GV	GC
ε_c	0.0035(Unconfined)	$0.0035+0.01(\rho_s/\rho_{sm})\leq 0.0135$	$0.004+0.014(\rho_s/\rho_{sm})\leq 0.018$
ε_s	0.01	0.04	0.06

At Table 3.4. Section strain limits of unconfined concrete (MN) at extreme concrete fiber , confined concrete strain limit (GV and GC) and reinforcing steel strain limits are given .“MN” corresponds to “*Immediate Occupancy*” performance level, “GV” corresponds to “*Life Safety*” performance level and “GC” corresponds to “*Collapse prevention*” performance level.

Total curvature at corresponding strain limit at related performance level is taken and yield curvature is subtracted to find plastic curvature of the section. Then plastic curvature is transformed to plastic rotation by multiplying the plastic curvature with plastic hinge length (D/2).

Table 3.5. Models that are used

Model Number	Performance Level	Confinement	Section Dimension	Concrete	Steel	Reinforcement Ratio
1	IO	Unconfined	50X50-60X30-30X60	20	420	2
2	LS	Unconfined	50X50-60X30-30X60	20	420	2
3	CP	Unconfined	50X50-60X30-30X60	20	420	2
4	IO	Confined	50X50-60X30-30X60	20	220	1
5	LS	Confined	50X50-60X30-30X60	20	220	1
6	CP	Confined	50X50-60X30-30X60	20	220	1
7	IO	Inconfined-SemiConfined-Confine	50x50	20	420	2
8	LS	Inconfined-SemiConfined-Confine	50x50	20	420	2
9	CP	Inconfined-SemiConfined-Confine	50x50	20	420	2
10	IO	Unconfined	50x50	14	220	1-2-3-4
11	LS	Unconfined	50x50	14	220	1-2-3-4
12	CP	Unconfined	50x50	14	220	1-2-3-4
13	IO	Confined	50x50	20	420	1-2-3-4
14	LS	Confined	50x50	20	420	1-2-3-4
15	CP	Confined	50x50	20	420	1-2-3-4
16	IO	Unconfined	50x50	20-14-10	220	1
17	LS	Unconfined	50x50	20-14-10	220	1
18	CP	Unconfined	50x50	20-14-10	220	1
19	IO	Confined	50x50	20-25	420	1
20	LS	Confined	50x50	20-25	420	1
21	CP	Confined	50x50	20-25	420	1
22	IO	Unconfined	50x50	20	220-420	1
23	LS	Unconfined	50x50	20	220-420	1
24	CP	Unconfined	50x50	20	220-420	1

Blue highlighted models are for investigation sectional properties. *Yellow* highlighted models are for investigation compressive strength of concrete effect. *Cyan* highlighted models are for investigation reinforcing steel properties. *Magenta* highlighted models are for investigation confinement properties. *Green* models for investigation reinforcement ratio are of the section.

Three grades of concrete quality (C10 $f_{ck}=10\text{MPa}$, C14 $f_{ck}=14\text{MPa}$, C20 $f_{ck}=20\text{MPa}$) for unconfined sections and two grades of concrete quality (C20 $f_{ck}=20\text{MPa}$, C25 $f_{ck}=25\text{MPa}$) for confined sections have been considered. Two grades of steel classes (S420 $f_{yk}=420\text{MPa}$, S220 $f_{yk}=220\text{MPa}$) have been used in unconfined section analysis.

All the sections analyzed in this study have constant reinforcement configuration with 'eight bars' and the location of the bars are determined for constant d'/d ratio of 0.08.

At thesis prepared by Şadan (2005), strain based performance evaluation Charts had been constructed by performing axial load- bending moment interaction analysis for each performance level and the curvature of the cross section for each axial load level has been determined. The axial force- curvature charts specified for each section type had been converted to dimensionless scale by dividing the axial loads by section area and characteristic concrete strength, and multiplying the curvature values by plastic hinge length. Plastic hinge length has been taken as half of the effective depth of the section as in the TSC (2007).

3.2. Different Section Dimensions Effect on Compliance Criterion

As shown on Table 3.3, Plastic chord rotations are not allowed at “*Limited Damage*” which corresponds to “*Immediate Occupancy*” performance level at EN1998-3 (2005). So that, all “*Immediate Occupancy*” graphs line corresponds to EN1998-3 (2005) remained equal to zero for all axial force ratios.

When checking whether the performance evaluation charts are dependent to the unconfined section dimensions or not, three analyses had been shown with three different sections (50x50, 30x60 and 60x30).

3.2.1. $f_{ck}(20\text{Mpa})$, $f_{yk}(420\text{Mpa})$, %2, Unconfined

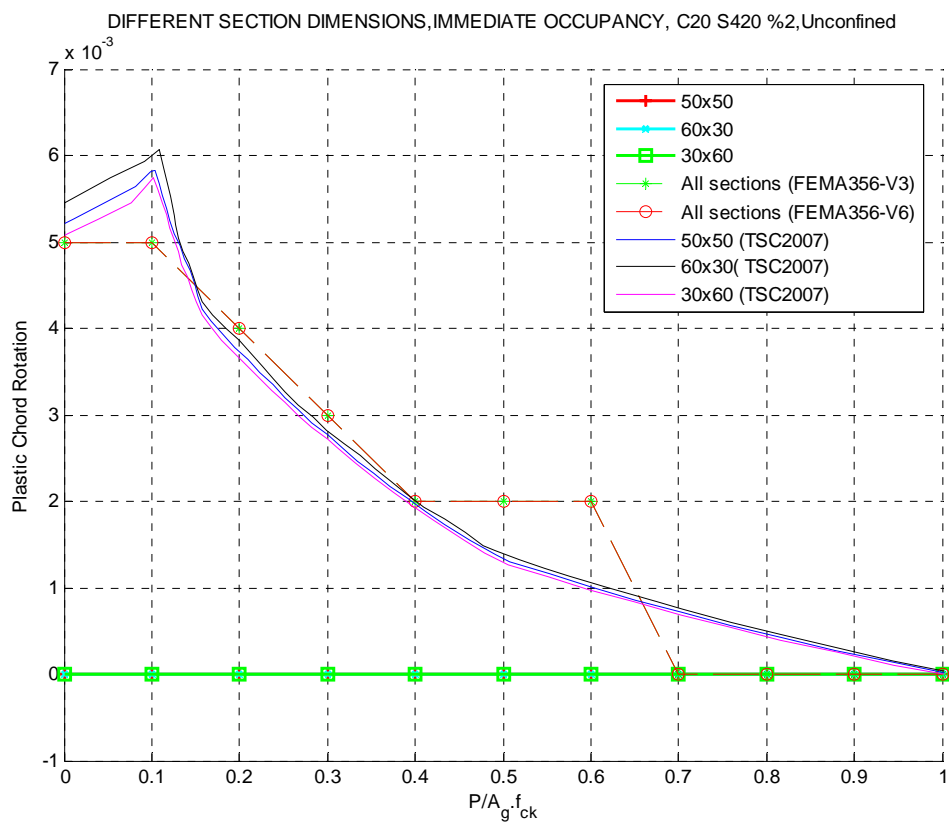

Figure 3.1. Plastic chord rotation vs. axial force ratio curve of Graph no: 1

FEMA356 (2000) and TSC (2007) looks very similar whereas EN1998-3 (2005) remains zero for Immediate Occupancy level.

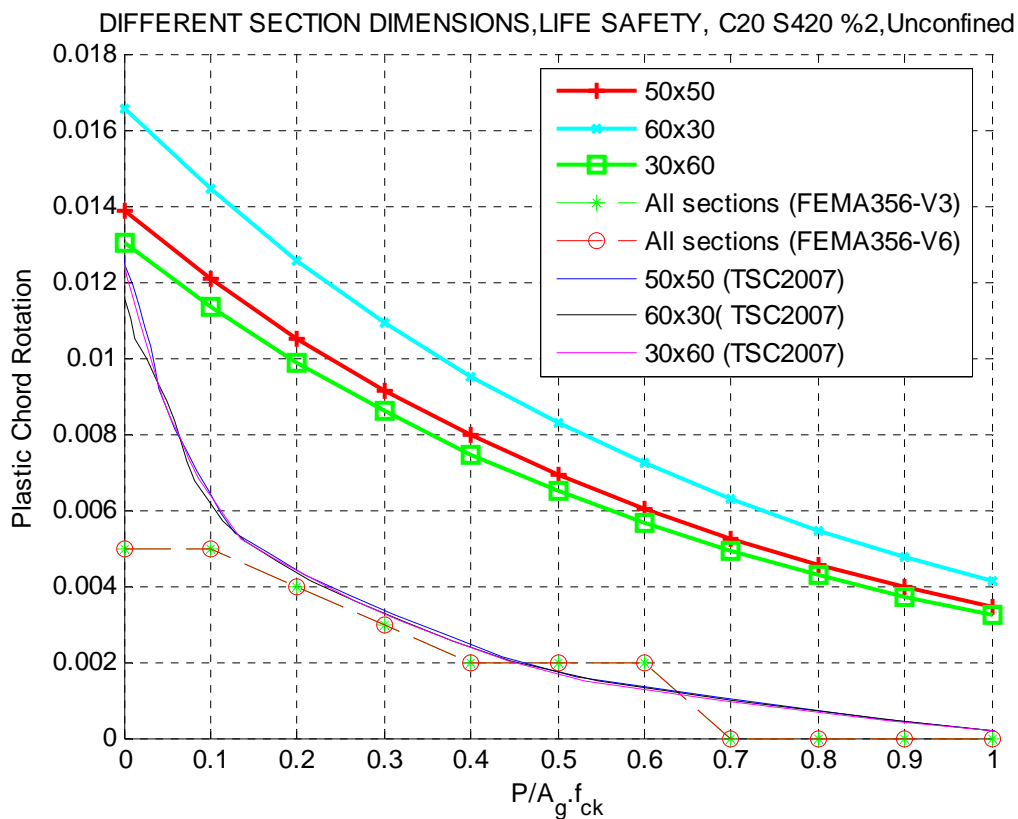

Figure 3.2. Plastic chord rotation vs. axial force ratio curve of Graph no: 2

FEMA356 (2000) and TSC (2007) looks very similar below axial force ratio ($P/A_g f_{ck}$) equals to 0.1, whereas EN1998-3 (2005) remains higher for Life Safety Performance level.

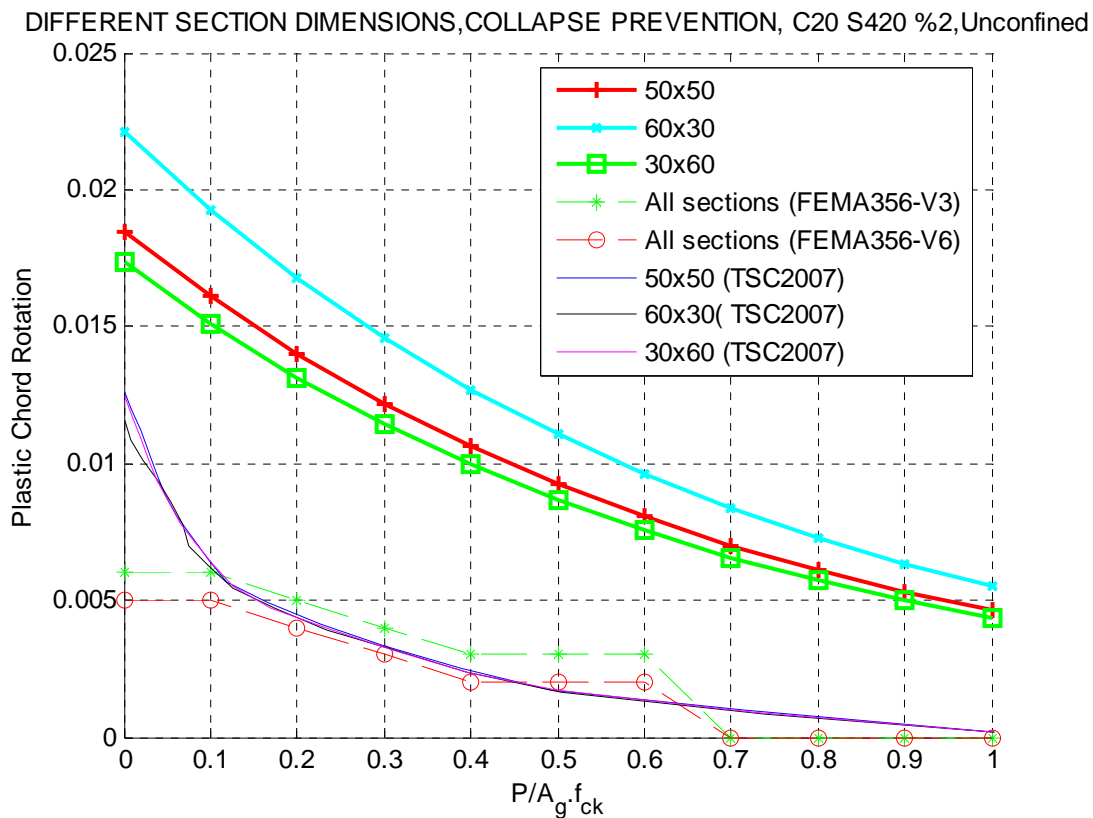

Figure 3.3. Plastic chord rotation vs. axial force ratio curve of Graph no: 3

FEMA356 (2000) and TSC (2007) looks very similar below axial force ratio ($P/A_g F_{ck}$) equals to 0.1, whereas EN1998-3 (2005) remains higher for Collapse prevention Performance level.

3.2.2. $f_{ck}(20\text{Mpa})$, $f_{yk}(220\text{Mpa})$, %2, Confined

When checking whether the performance evaluation charts are dependent to the unconfined section dimensions or not, three analyses had been shown with three different sections (50x50, 30x60 and 60x30).

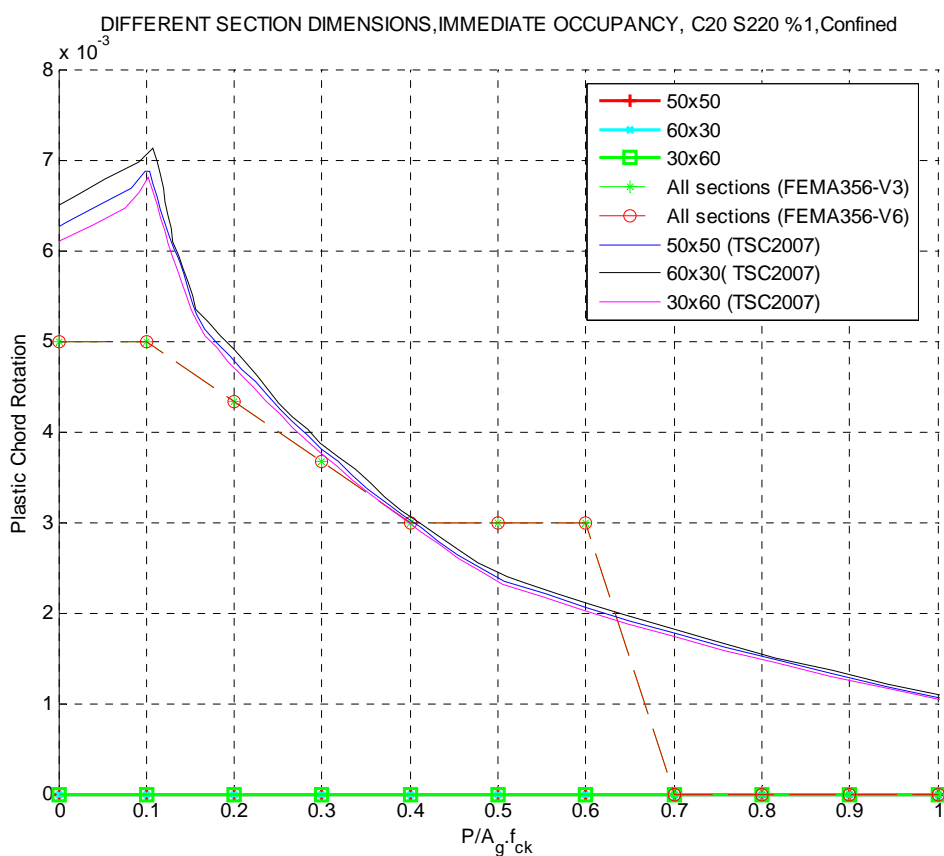

Figure 3.4. Plastic chord rotation vs. axial force ratio curve of Graph no: 4

FEMA356 (2000) and TSC (2007) looks very similar whereas EN1998-3 (2005) remains zero for Immediate Occupancy performance level.

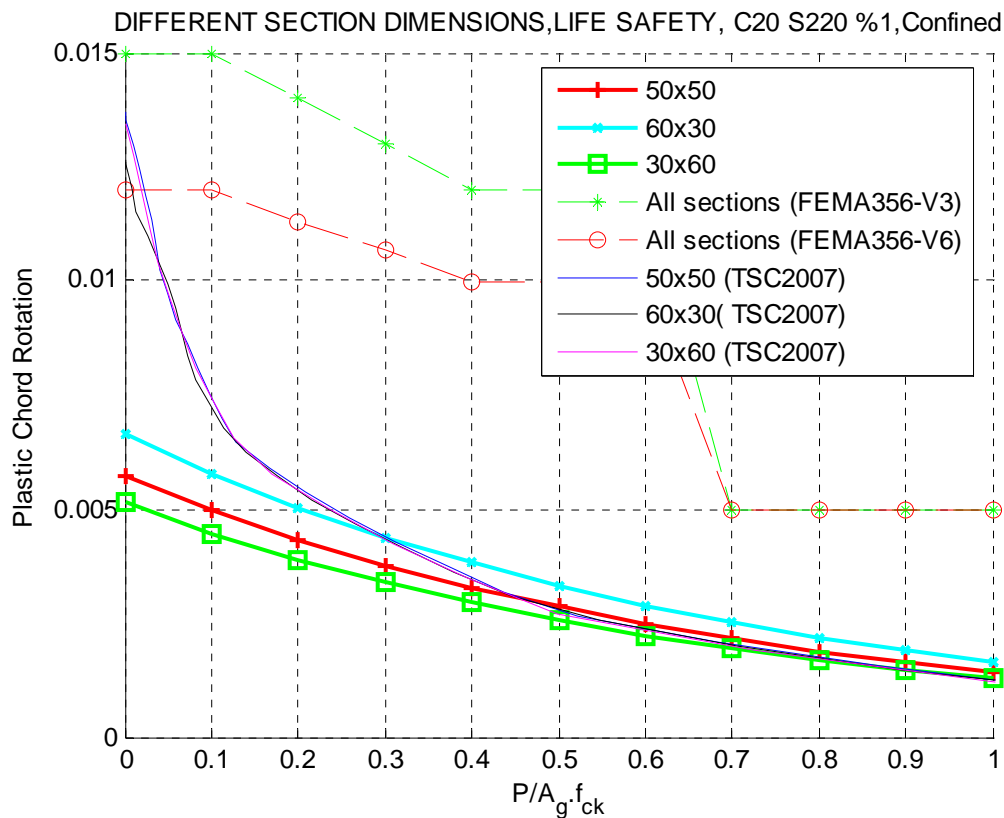

Figure 3.5. Plastic chord rotation vs. axial force ratio curve of Graph no: 5

TSC (2007) And EN1998-3 (2005) looks very similar below axial force ratio ($P/A_g f_{ck}$) equals to 0.2, whereas FEMA356 (2000) remains higher for Life Safety performance level.

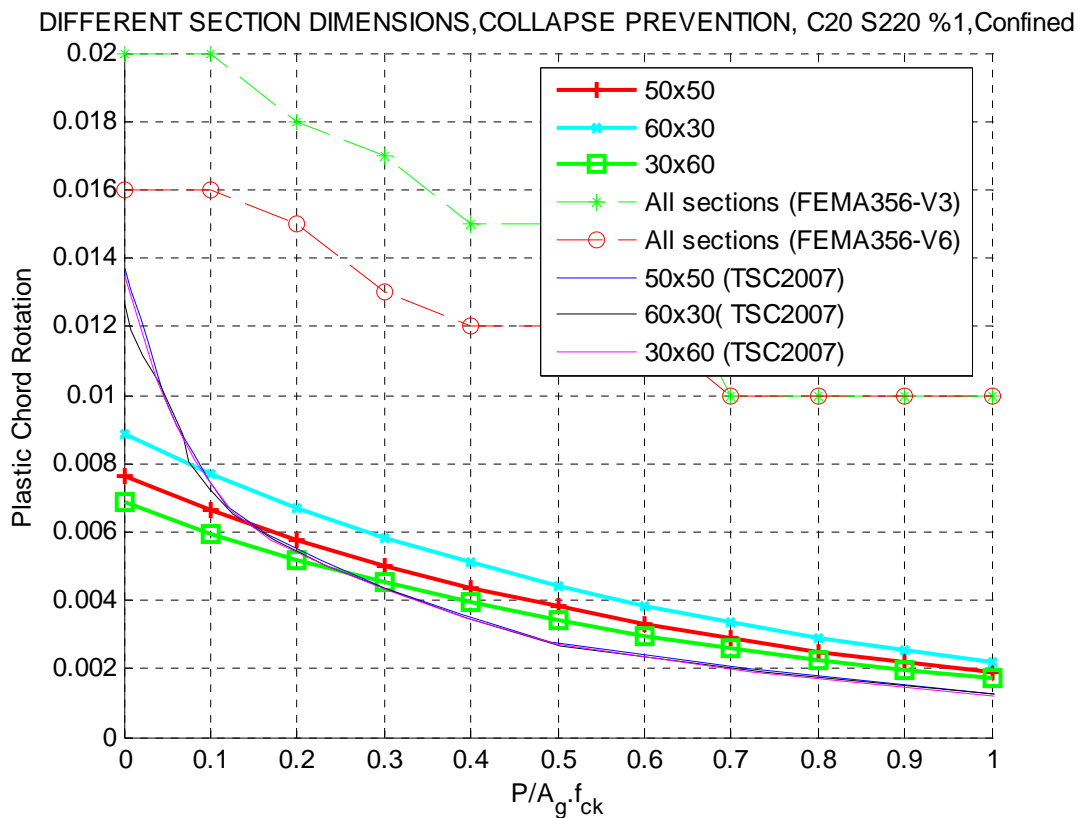

Figure 3.6. Plastic chord rotation vs. axial force ratio curve of Graph no: 6

TSC (2007) And EN1998-3 (2005) looks very similar below axial force ratio ($P/A_g F_{ck}$) equals to 0.1, whereas FEMA356 (2000) remains higher for Collapse Prevention performance level.

3.3. Effect of Different Confinement Properties on Compliance Criterion

Unconfined sections are considered as without transversal reinforcement. Confined sections transversal reinforcement ratio is equal to equation (3.1). On the other hand semi-confined sections transversal reinforcement ratio is considered as half of confined section.

$$\rho_s = \frac{A_{sh}}{s.b_k} \geq 0.075 \left(\frac{f_{ck}}{f_{yk}} \right) \quad (3.1)$$

As shown on Table 3.3, Plastic chord rotations are not allowed at “*Limited Damage*” which corresponds to “*Immediate Occupancy*” performance level at EN1998-3 (2005). So that, all “*Immediate Occupancy*” graphs line corresponds to EN1998-3 (2005) remained equal to zero for all axial force ratios.

When checking whether the performance evaluation charts are dependent to the confinement properties or not, three analyses FEMA356 (2000) EN1998-3 (2005) TSC (2007) had been shown for three different confinement levels (Confined, Semi-confined and Confined).

3.3.1. 50x50, f_{ck} (20Mpa), f_{yk} (420Mpa), %2

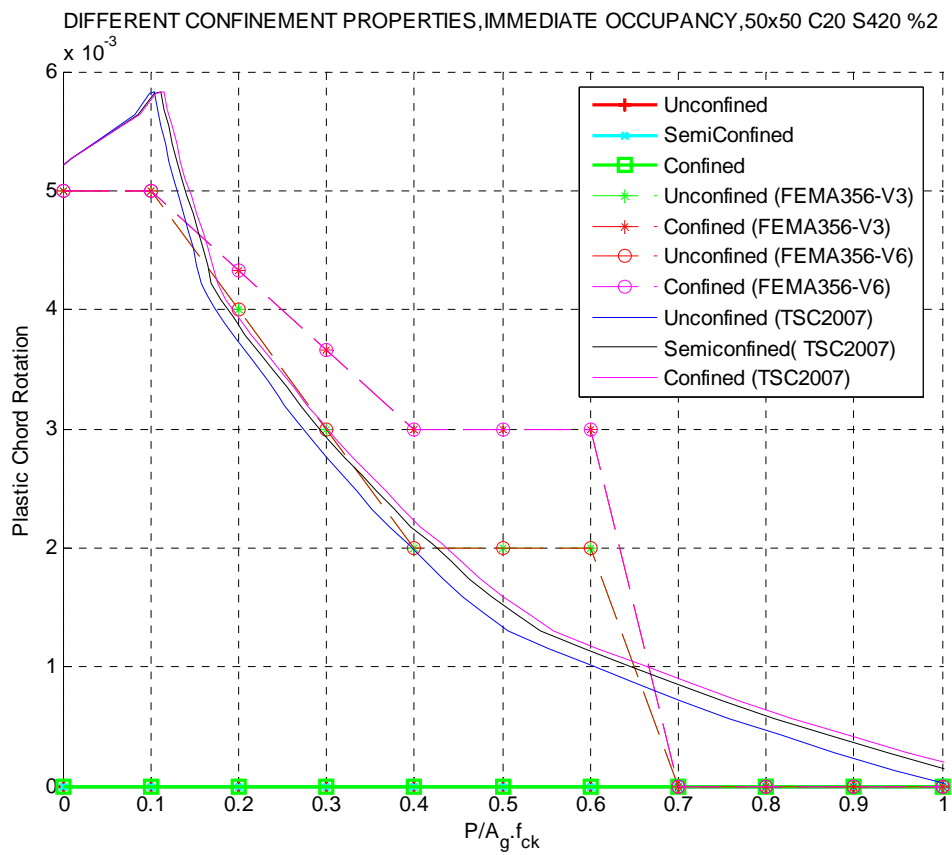

Figure 3.7. Plastic chord rotation vs. axial force ratio curve of Graph no: 7

FEMA356 (2000) and TSC (2007) looks very similar whereas EN1998-3 (2005) remains zero for Immediate Occupancy performance level.

3.4.1. 50x50, f_{ck} (14Mpa), f_{yk} (220Mpa), Unconfined

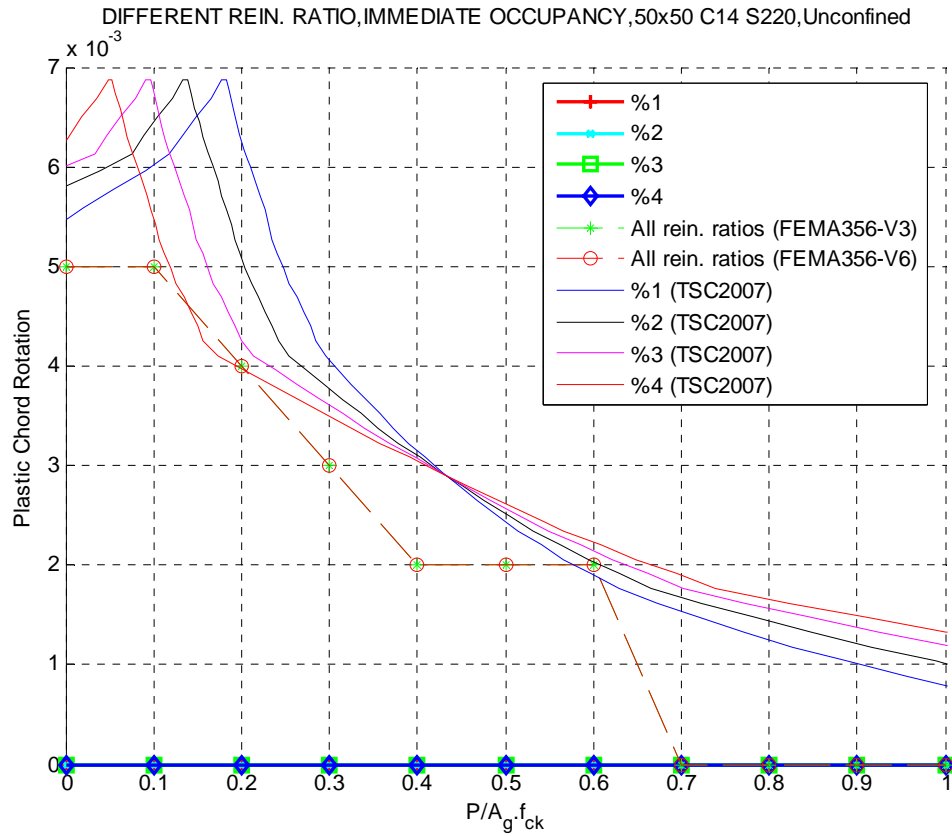

Figure 3.10. Plastic chord rotation vs. axial force ratio curve of Graph no: 10

FEMA356 (2000) and TSC (2007) looks very similar whereas EN1998-3 (2005) remains zero for Immediate Occupancy performance level.

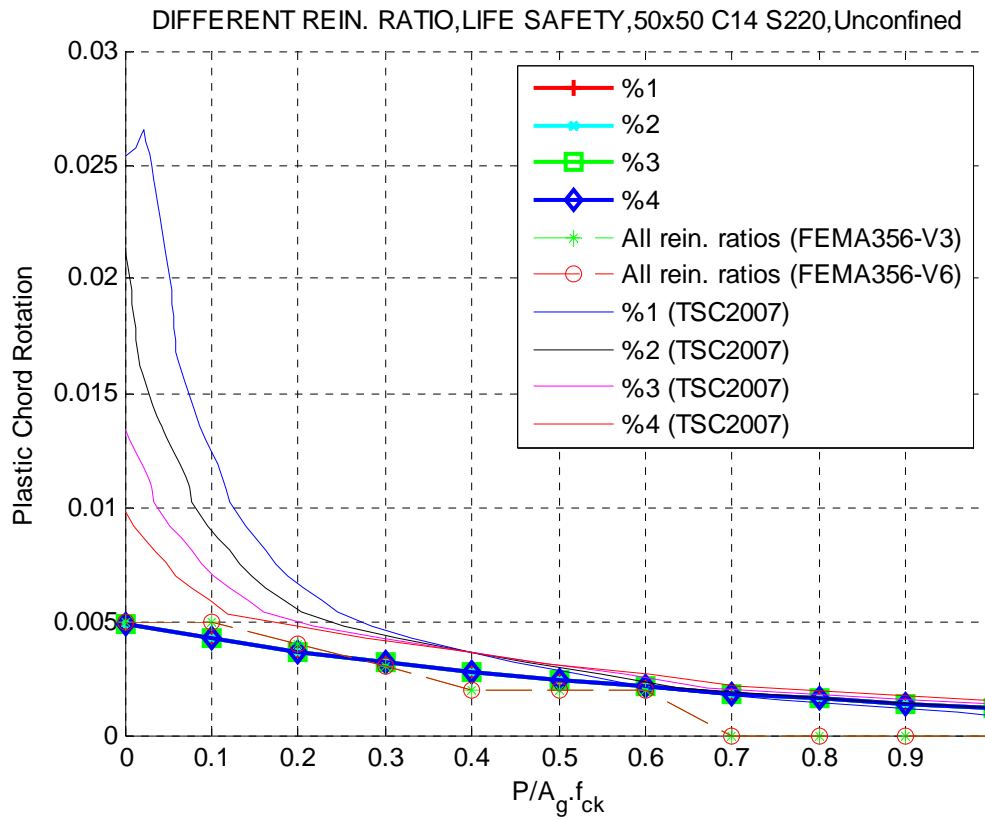

Figure 3.11. Plastic chord rotation vs. axial force ratio curve of Graph no: 11

TSC (2007), FEMA356 (2000) and EN1998-3 (2005) looks very similar below axial force ratio ($P/A_g F_{ck}$) equals to 0.2 for Life Safety performance level.

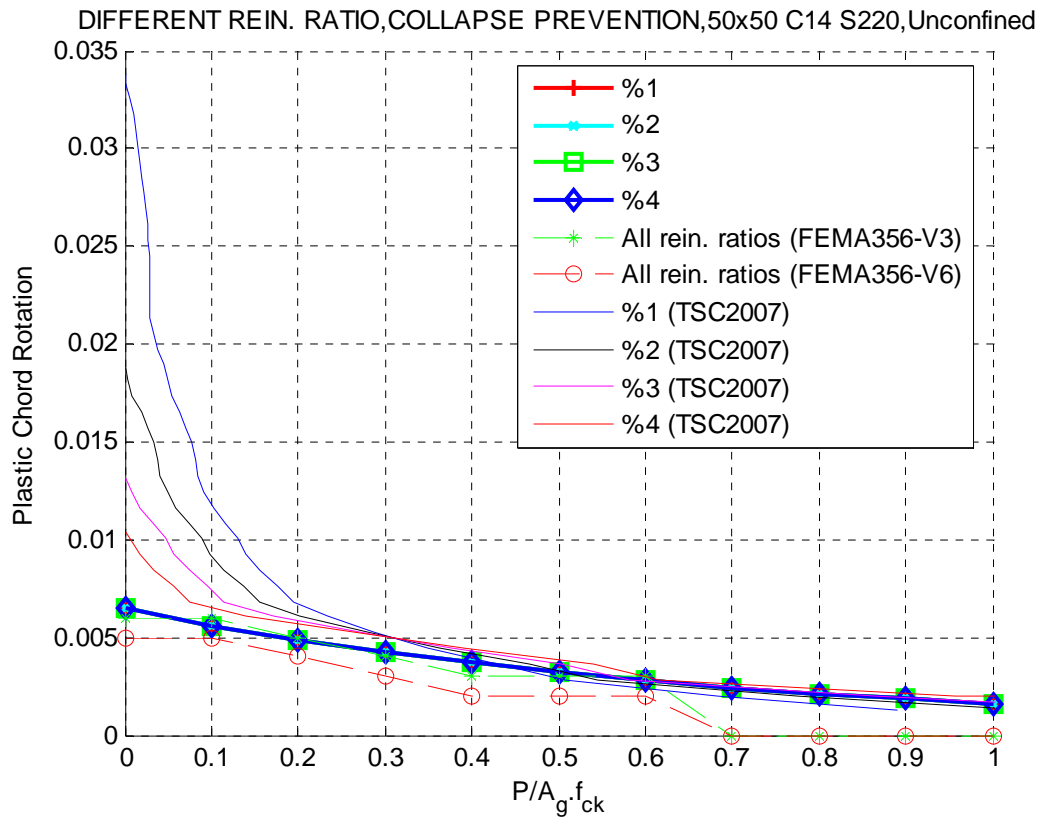

Figure 3.12. Plastic chord rotation vs. axial force ratio curve of Graph no: 12

TSC (2007), FEMA356 (2000) and EN1998-3 (2005) looks very similar below axial force ratio ($P/A_g F_{ck}$) equals to 0.2 for Collapse Prevention performance level.

3.4.2. 50x50, fck (20Mpa), fyk(420Mpa), Confined

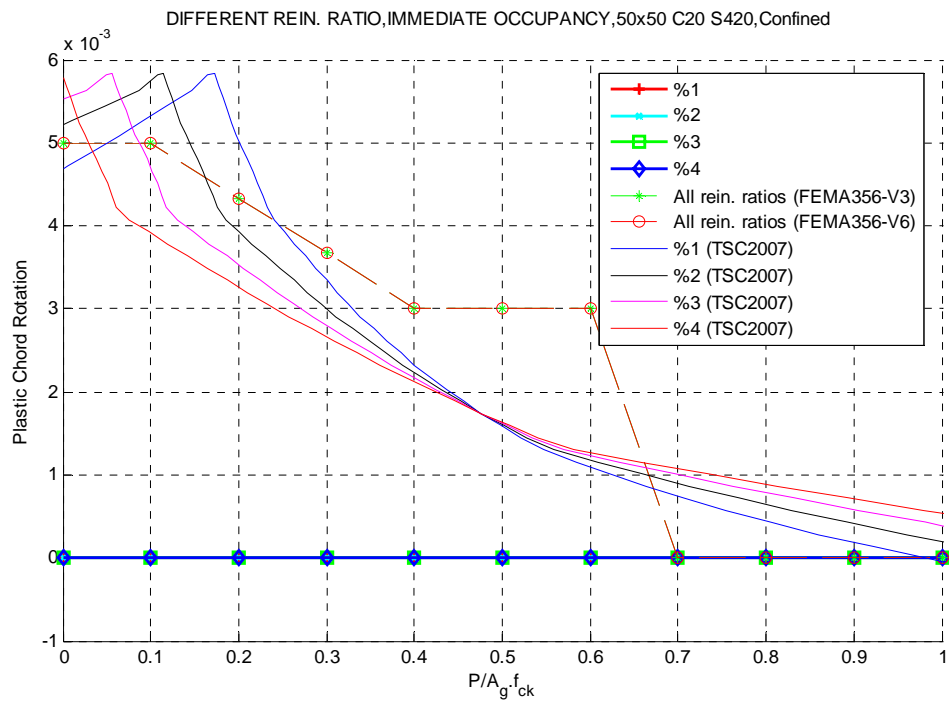

Figure 3.13. Plastic chord rotation vs. axial force ratio curve of Graph no: 13

FEMA356 (2000) and TSC (2007) looks very similar whereas EN1998-3 (2005) remains zero for Immediate Occupancy performance level.

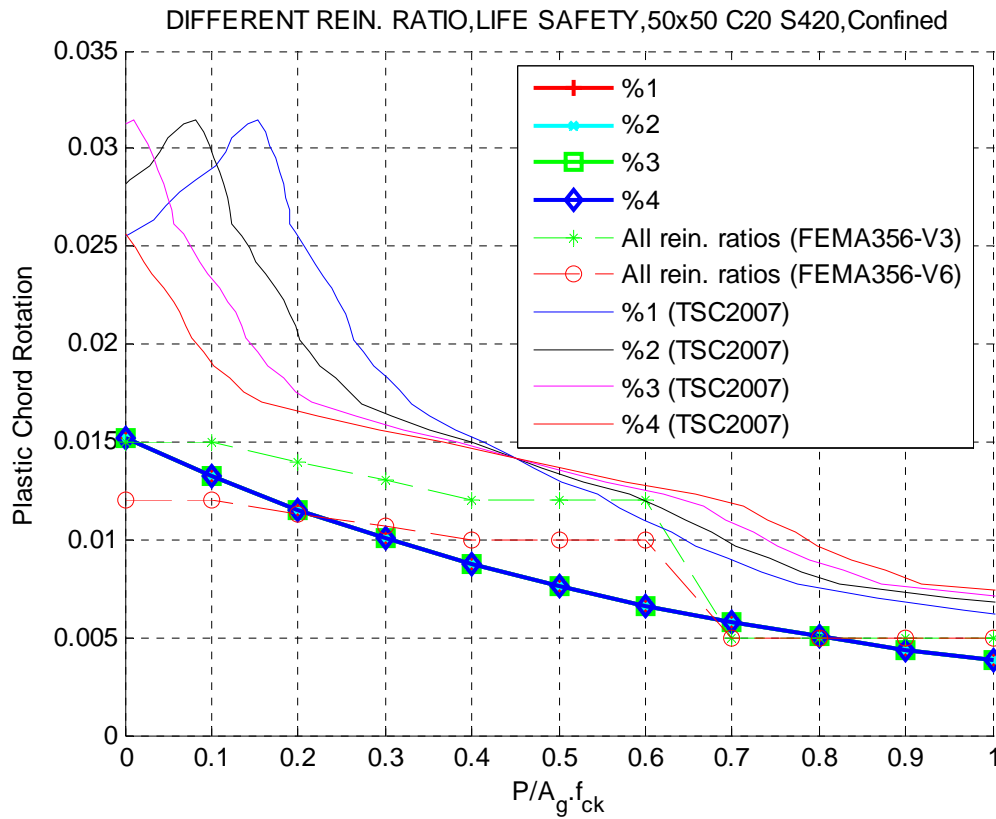

Figure 3.14. Plastic chord rotation vs. axial force ratio curve of Graph no: 14

EN1998-3 (2005) and FEMA356 (2000) looks quite similar, whereas TSC (2007) remains higher for Life Safety Performance level.

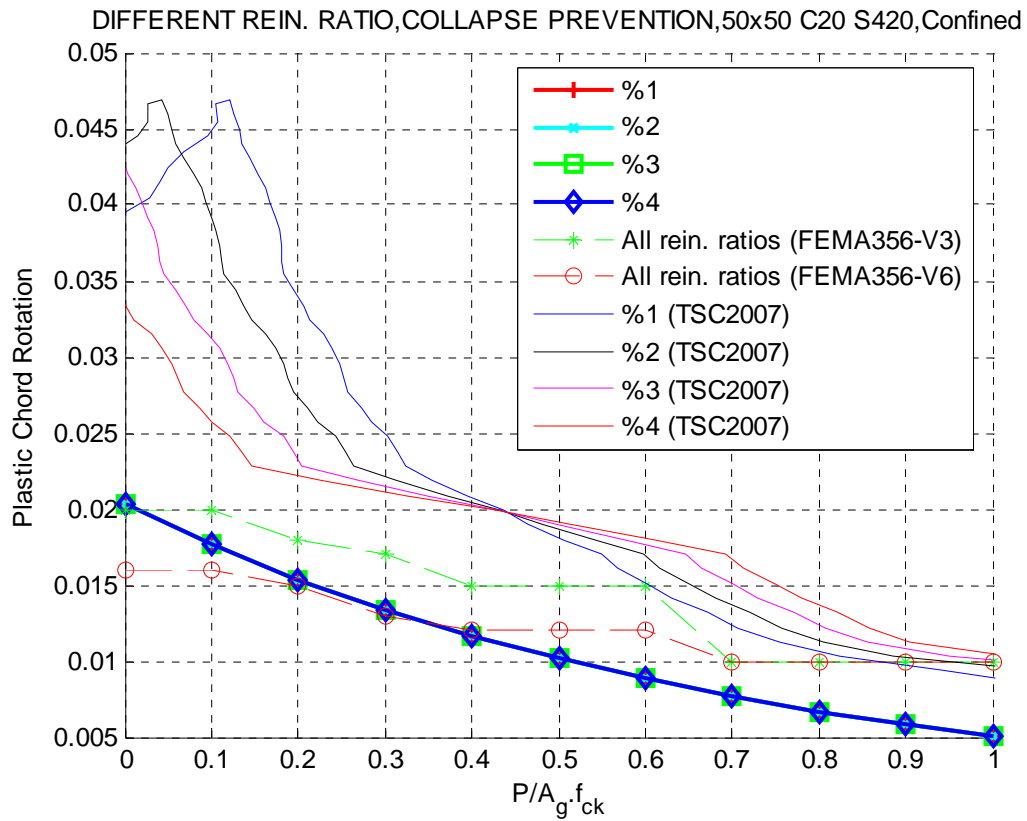

Figure 3.15. Plastic chord rotation vs. axial force ratio curve of Graph no: 15

EN1998-3 (2005) and FEMA356 (2000) looks quite similar, whereas TSC (2007) remains higher for Collapse Prevention Performance level.

3.5. Effect of Different Concrete Strength Levels on Compliance Criterion

3.5.1. 50x50, $f_{yk}(220\text{Mpa})$, %1, Unconfined

Three grades of concrete quality (C10 $f_{ck}=10\text{MPa}$, C14 $f_{ck}=14\text{MPa}$, C20 $f_{ck}=20\text{MPa}$) for unconfined sections have been used in unconfined section analysis.

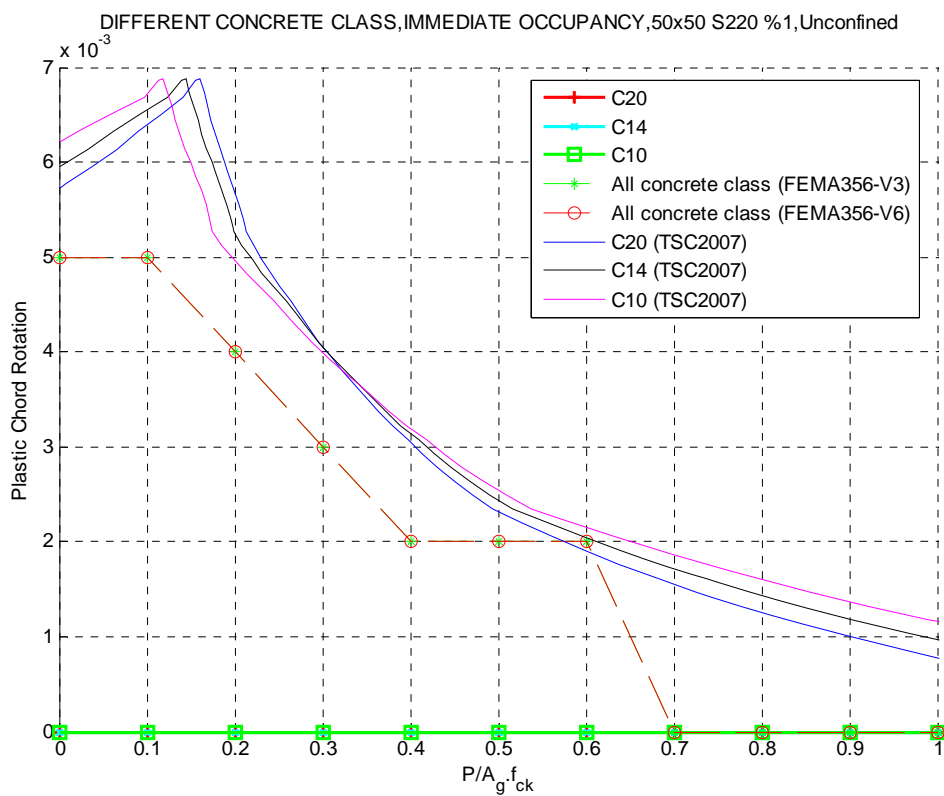

Figure 3.16. Plastic chord rotation vs. axial force ratio curve of Graph no: 16

FEMA356 (2000) and TSC (2007) looks very quite whereas EN1998-3 (2005) remains zero for Immediate Occupancy performance level.

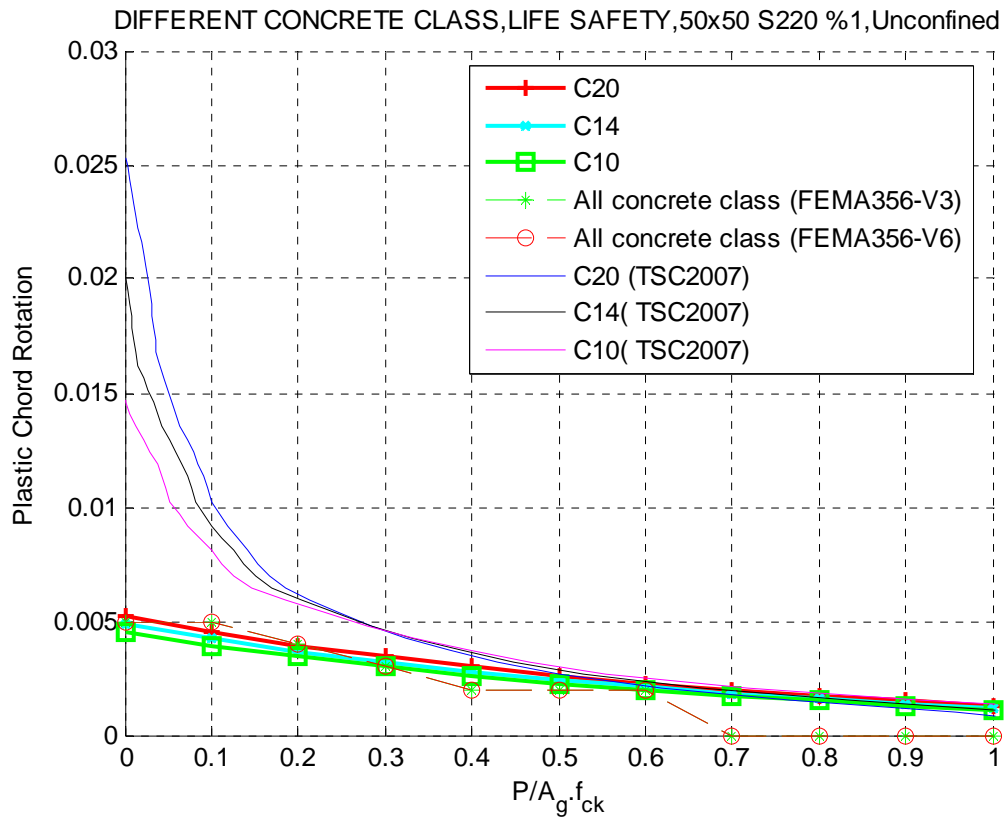

Figure 3.17. Plastic chord rotation vs. axial force ratio curve of Graph no: 17

TSC (2007), FEMA356 (2000) and EN1998-3 (2005) looks very similar above axial force ratio ($P/A_g F_{ck}$) equals to 0.2 for Life Safety performance level.

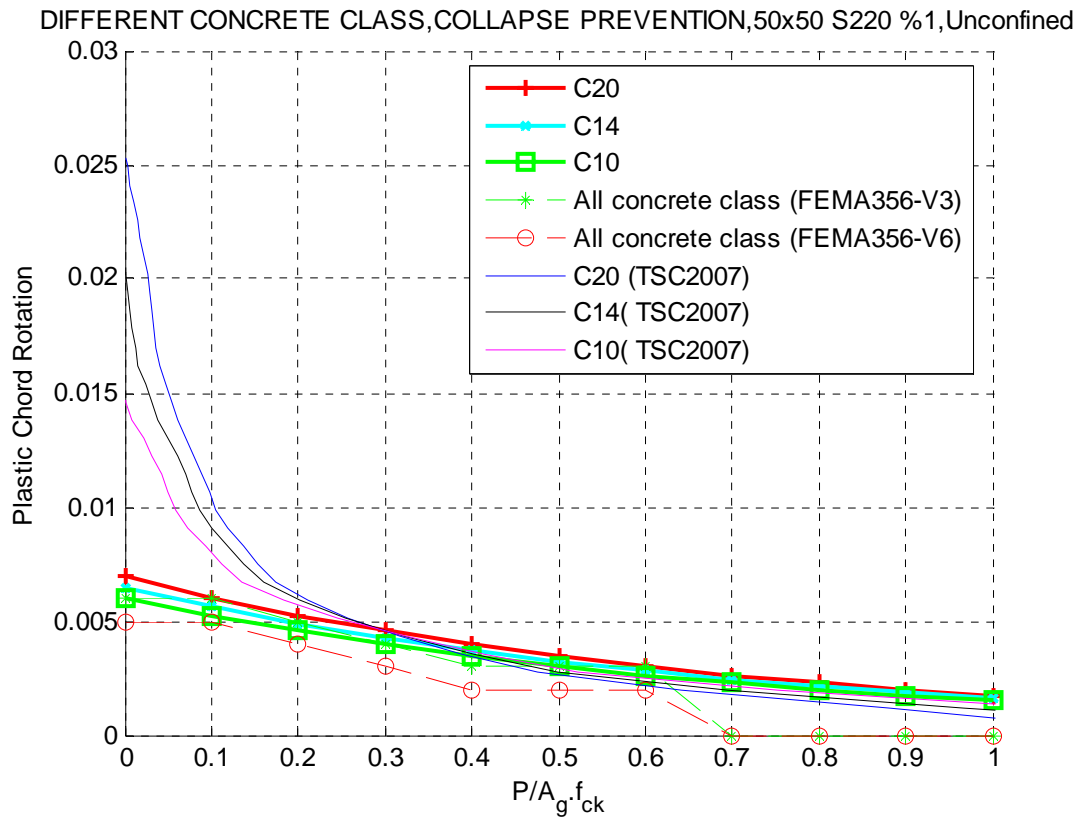

Figure 3.18. Plastic chord rotation vs. axial force ratio curve of Graph no: 18

TSC (2007), FEMA356 (2000) and EN1998-3 (2005) looks very similar above axial force ratio ($P/A_g F_{ck}$) equals to 0.2 for Collapse Prevention performance level.

3.5.2. 50x50, $f_{yk}(220\text{Mpa})$, %1, Confined

Two grades of concrete quality (C20 $f_{ck}=20\text{MPa}$, C25 $f_{ck}=25\text{MPa}$) for confined sections have been considered.

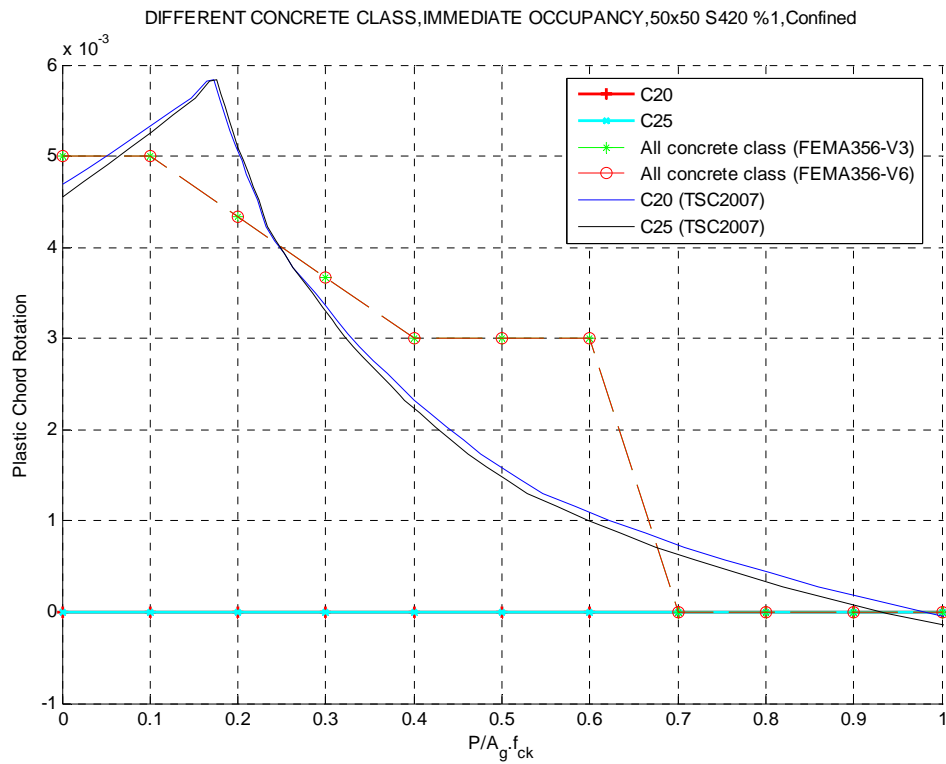

Figure 3.19. Plastic chord rotation vs. axial force ratio curve of Graph no: 19

FEMA356 (2000) and TSC (2007) looks quite similar whereas EN1998-3 (2005) remains zero for Immediate Occupancy performance level.

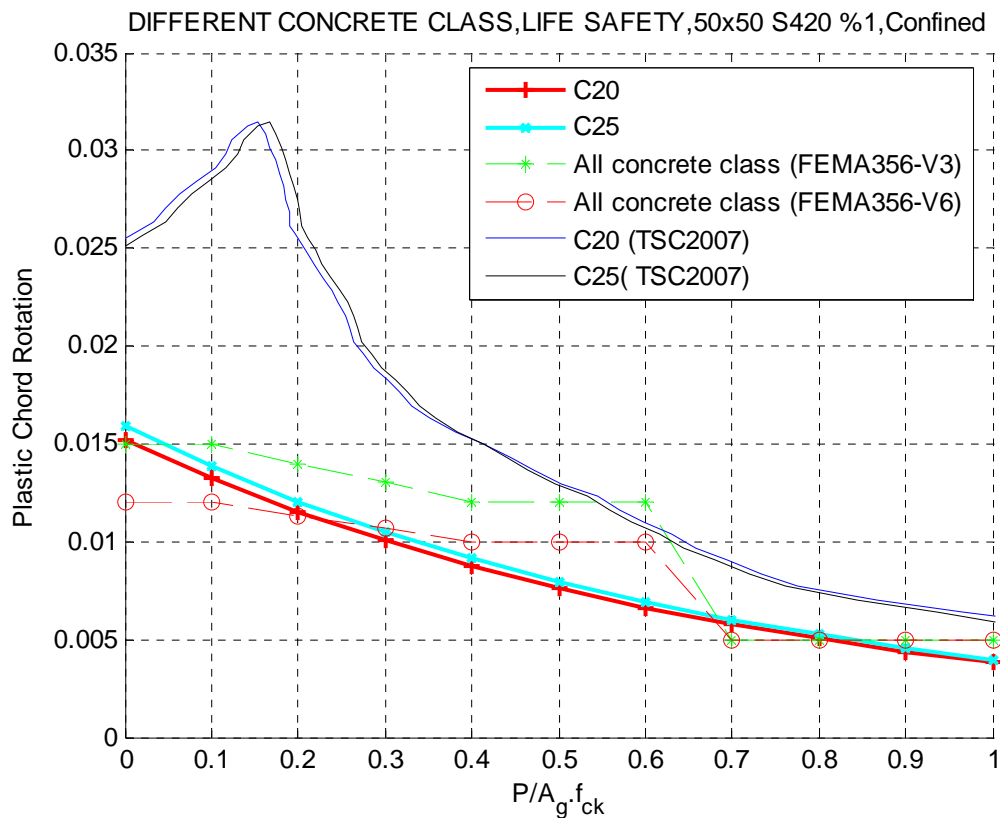

Figure 3.20. Plastic chord rotation vs. axial force ratio curve of Graph no: 20

EN1998-3 (2005) and FEMA356 (2000) looks quite similar, whereas TSC (2007) remains higher for Life Safety Performance level.

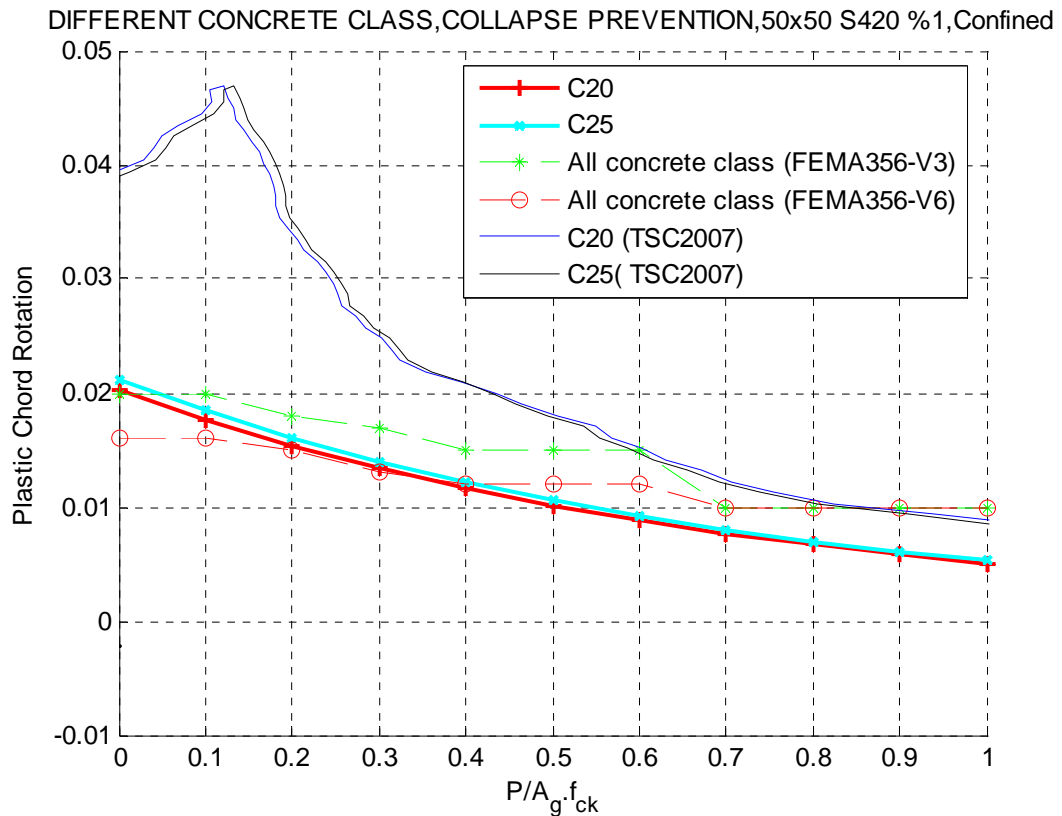

Figure 3.21. Plastic chord rotation vs. axial force ratio curve of Graph no: 21

EN1998-3 (2005) and FEMA356 (2000) looks quite similar, whereas TSC (2007) remains higher for Life Safety Performance level.

3.6. Effect of Different Steel Strength Classes on Compliance Criterion

3.6.1. 50x50, $f_{ck}(20\text{Mpa}), \%1$, Unconfined

Three grades of steel classes (S220 $f_{yk}=220\text{MPa}$, S420 $f_{yk}=420\text{MPa}$,) for unconfined sections have been used in unconfined section analysis.

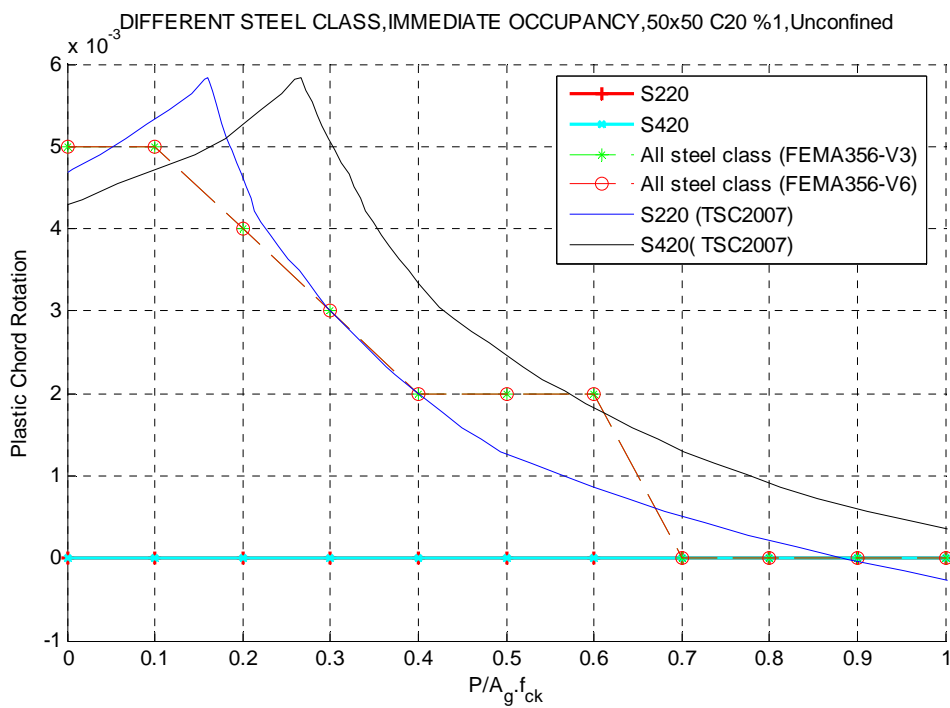

Figure 3.22. Plastic chord rotation vs. axial force ratio curve of Graph no: 22

FEMA356 (2000) and TSC (2007) looks very quite similar whereas EN1998-3 (2005) remains zero for Immediate Occupancy performance level.

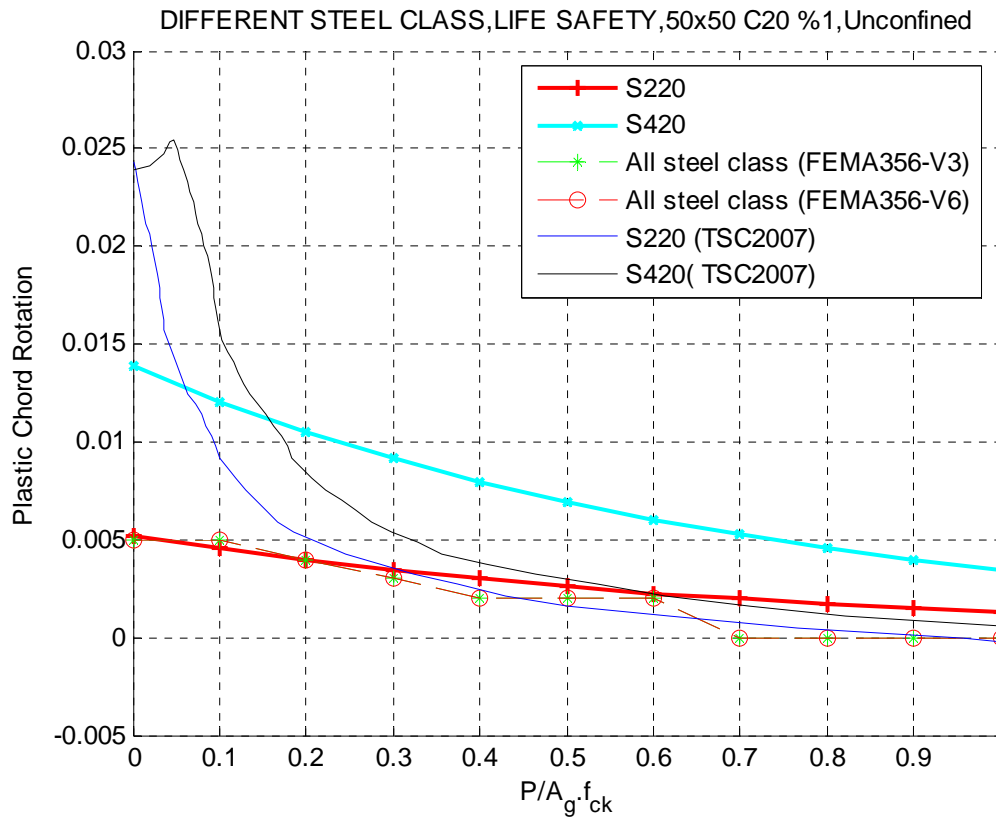

Figure 3.23. Plastic chord rotation vs. axial force ratio curve of Graph no: 23

EN1998-3 (2005), FEMA356 (2000) and TSC (2007) looks quite similar, above 0.2 axial force ratio except S420 graph of EN1998-3 (2005) for Life Safety Performance level.

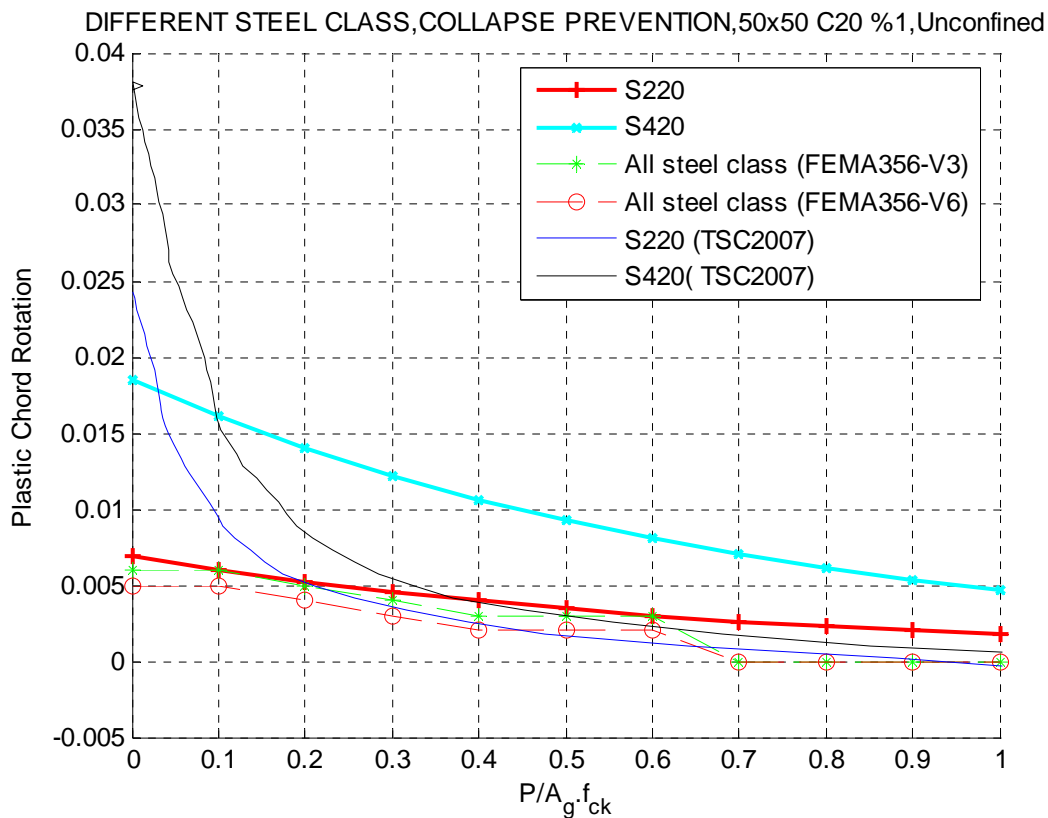

Figure 3.24. Plastic chord rotation vs. axial force ratio curve of Graph no: 24

EN1998-3 (2005), FEMA356 (2000) and TSC (2007) looks quite similar, above 0.2 axial force ratio except S420 graph of EN1998-3 (2005) for Collapse Prevention Performance level.

4. COMPARISON OF TOTAL CHORD ROTATION CALCULATIONS

In this chapter, total chord rotation empirical formulas will be compared. Total chord rotation is sum of plastic chord rotation plus yield chord rotation. Total chord rotation and plastic chord rotation formulas at EN1998-3 (2005) are given at previous sections where (2.6) and (2.1) respectively.

$$\theta_{um} = \theta_{um}^{pl} + \theta_y \quad (4.1)$$

Yield chord rotation will be demonstrated firstly in this chapter. There are two alternative formulas existing at EN1998-3 (2005). However second alternative is used at FARDIS (2007). The yield chord rotation expression is as following for beams or rectangular columns.

$$\theta_y = \underbrace{\phi_y \frac{L_v + \alpha_v z}{3}}_{\text{Flexural}} + \underbrace{0.0013 \left(1 + 1.5 \frac{h}{L_s}\right)}_{\text{Shear deformation}} + \underbrace{\left(\frac{0.13 \phi_y d_b l f_y}{\sqrt{f_c}}\right)}_{\text{Anchorage slip of bars}} \quad (4.2)$$

The first term in expression (4.2) accounts for the flexural contribution. The second term represents the contribution of shear deformation and the third anchorage slip of bars.

where;

ϕ_y : yield curvature of the end section of the member (from 1st principles, possibly with correction factor);

$\alpha_v z$: tension shift of the bending moment diagram, with

z : length of internal lever arm, taken equal to the distance of the tension to the compression reinforcement, $z = d - d_1$, in beams, columns, or walls with barbelled or T-section, or to $z = 0.8h$ in walls with rectangular section, and

$\alpha_V=1$ if shear cracking precedes flexural yielding at the end section (i.e. when the yield moment at the end section, M_y , exceeds the product of L_s and of the shear resistance without shear reinforcement, $V_{R,c}$, according to Eurocode 2); otherwise, (i.e. if $M_y < L_s V_{R,c}$) $\alpha_V=0$;

L_v : = M/V , ratio moment/shear (shear span) at the end section;

h : section depth;

f_y, f_c : steel yield stress and concrete strength, respectively, in MPa;

d_{bL} : (mean) diameter of tension reinforcement;

4.1. Graphs and Charts

Total chord rotation expressions of described twelve sections will be graphed. Charts will consist of four chord rotation formula such as;

- Plastic chord rotation
- Plastic chord rotation + Yield rotation (only flexure contribution take into consideration)
- Plastic chord rotation + Yield rotation
- Total chord rotation

Table 4.1. Models that are used

Models	b [cm]	h [cm]	f_{ck} [MPa]	f_{yk} [MPa]	Transverse Steel
1	40	40	30	420	10/10 + 1 crosstie
2	40	40	25	420	10/10 + 1 crosstie
3	40	40	20	420	10/10 + 1 crosstie
4	40	40	15	420	10/10 + 1 crosstie
5	40	40	15	220	10/10 + 1 crosstie
6	30	40	15	220	10/10 + 1 crosstie
7	20	40	15	220	10/10 + 1 crosstie
8	40	30	15	220	10/10 + 1 crosstie
9	40	20	15	220	10/10 + 1 crosstie
10	40	40	15	220	8/20
11	40	40	15	220	8/30
12	40	40	15	220	6/30

Blue highlighted models are for investigation sectional properties. *Yellow* highlighted models are for investigation compressive strength of concrete effect. *Cyan* highlighted models are for investigation reinforcing steel properties. *Magenta* highlighted models are for investigation confinement properties.

4.1.1. 40x40, f_{ck} (30Mpa), f_{yk} (420Mpa), 10/10+1 crosstie

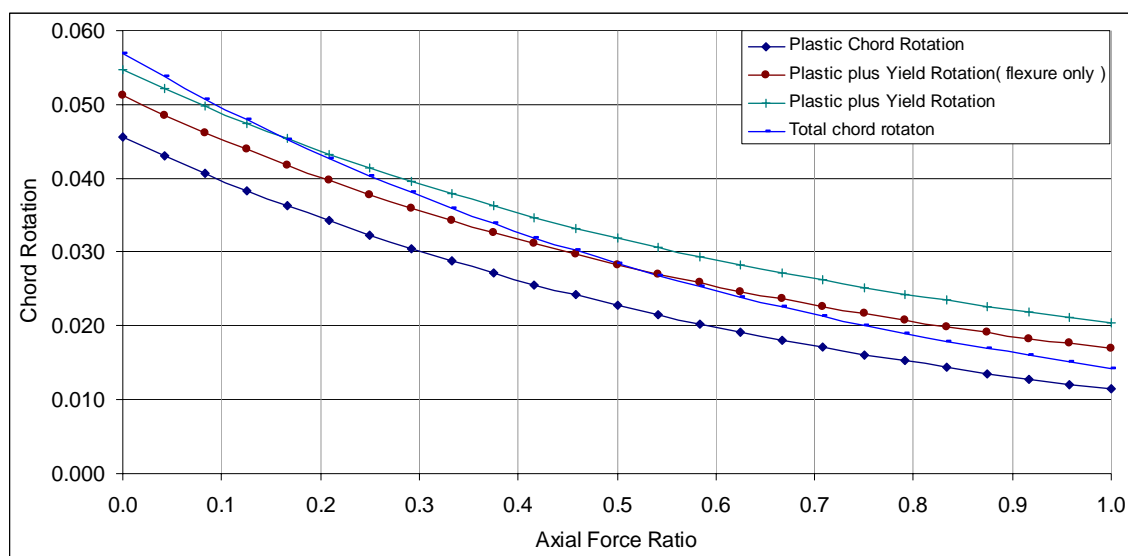

Figure 4.1. Chord rotation vs. axial force ratio curves of Model 1

4.1.2. 40x40, f_{ck} (25Mpa), f_{yk} (420Mpa), 10/10+1 crosstie

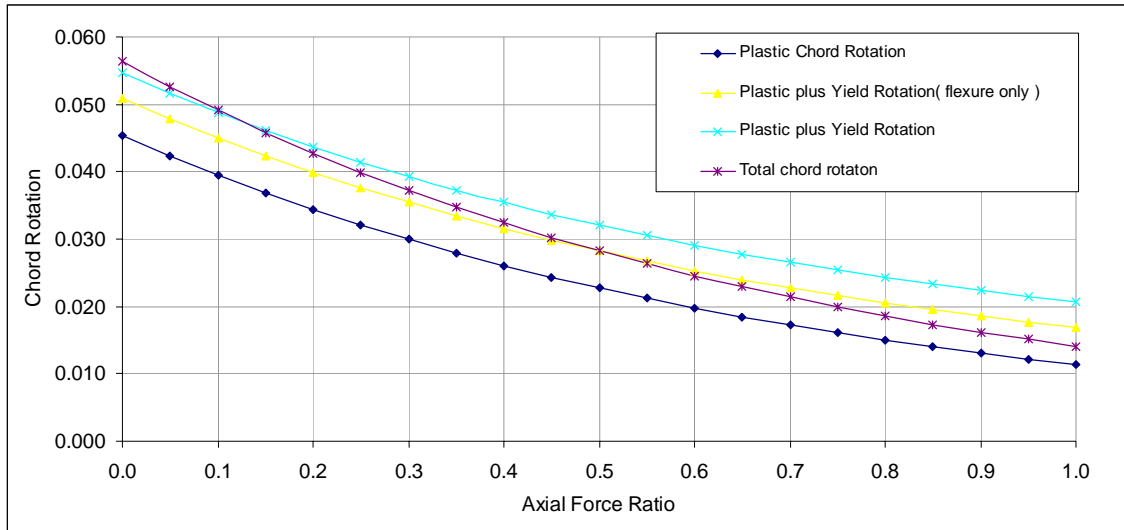

Figure 4.2. Chord rotation vs. axial force ratio curves of Model 2

4.1.3. 40x40, f_{ck} (20Mpa), f_{yk} (420Mpa), 10/10+1 crosstie

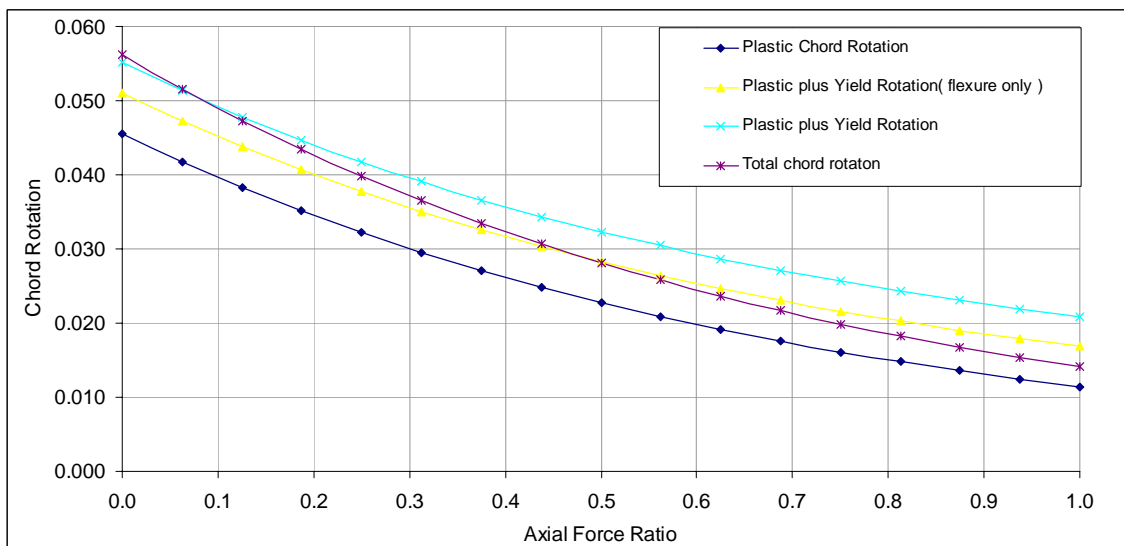

Figure 4.3. Chord rotation vs. axial force ratio curves of Model 3

4.1.4. 40x40, f_{ck} (15Mpa), f_{yk} (420Mpa), 10/10+1 crosstie

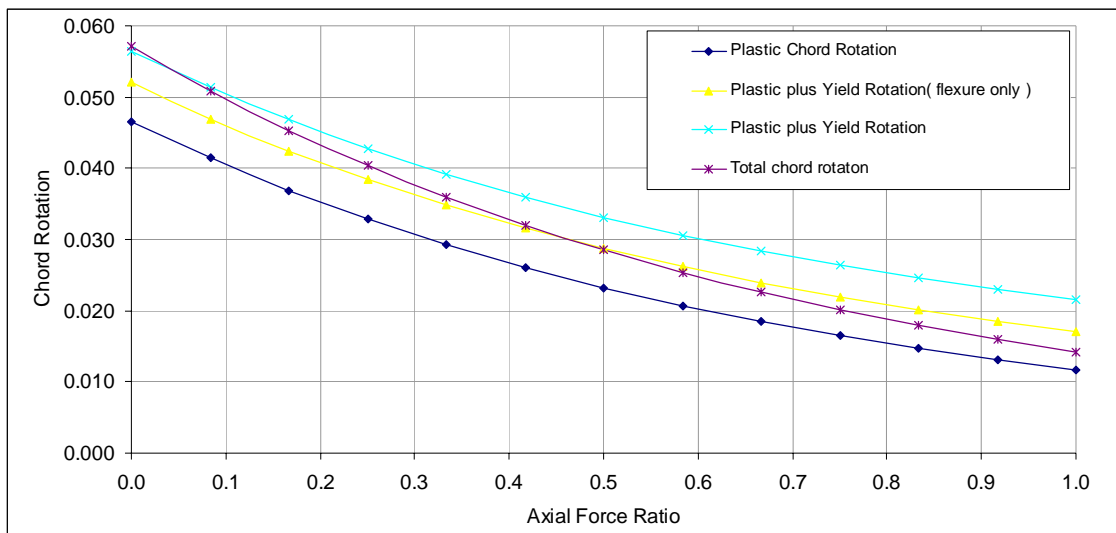

Figure 4.4. Chord rotation vs. axial force ratio curves of Model 4

4.1.5. 40x40, f_{ck} (15Mpa), f_{yk} (220Mpa), 10/10+1 crosstie

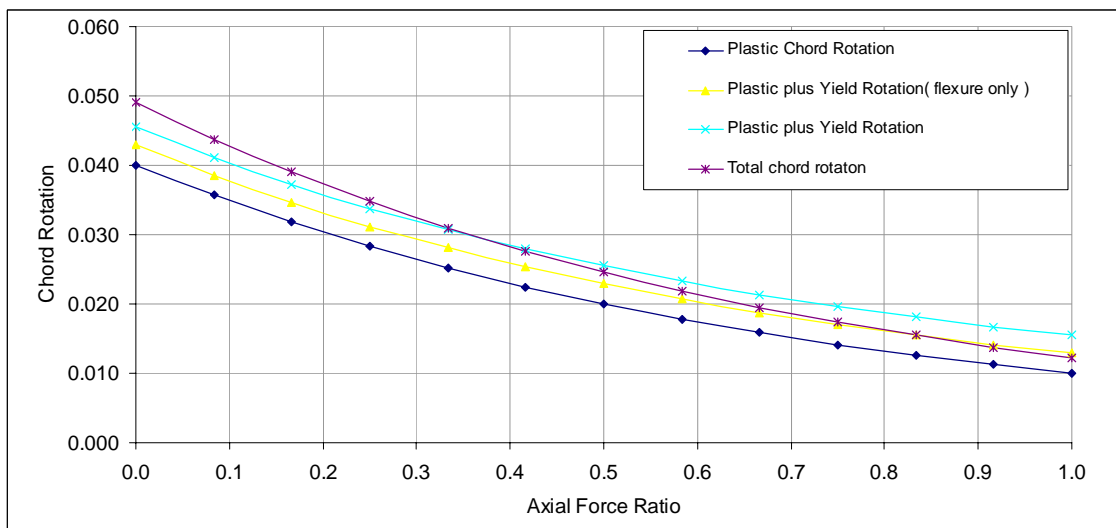

Figure 4.5. Chord rotation vs. axial force ratio curves of Model 5

4.1.6. 30x40, f_{ck} (15Mpa), f_{yk} (220Mpa), 10/10+1 crosstie

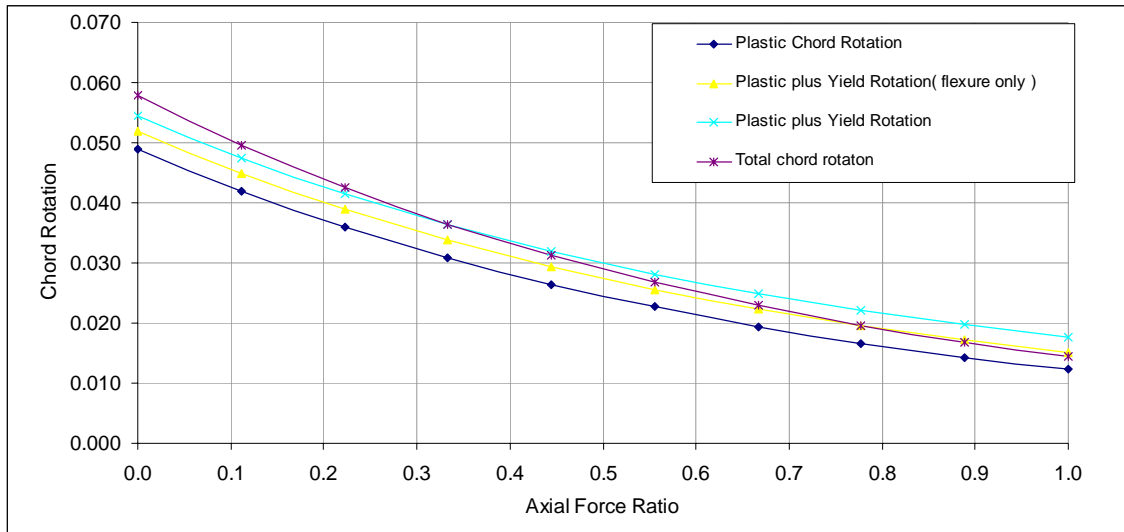

Figure 4.6. Chord rotation vs. axial force ratio curves of Model 6

4.1.7. 20x40, f_{ck} (30Mpa), f_{yk} (420Mpa), 10/10+1 crosstie

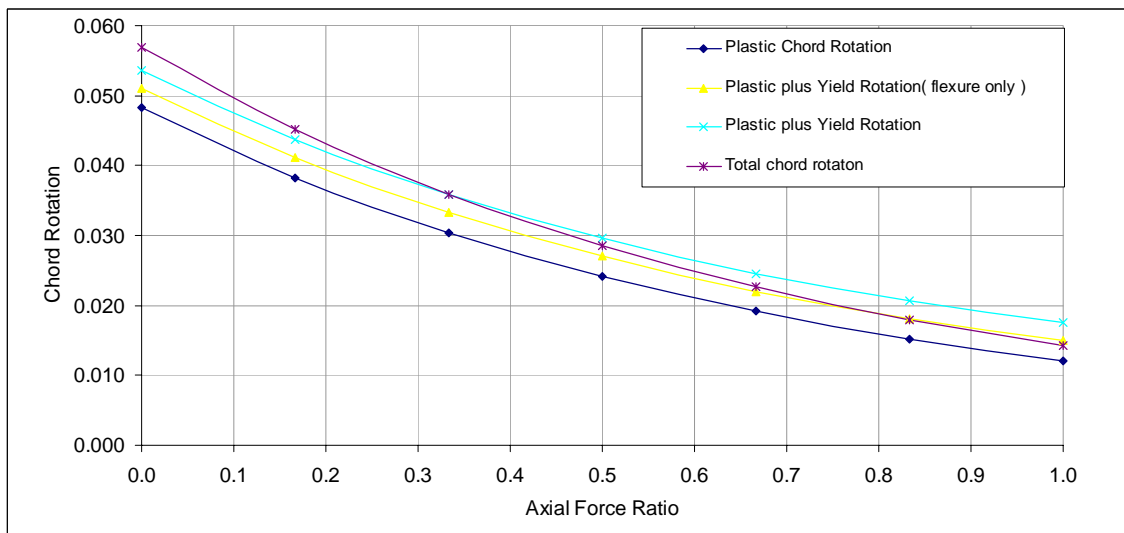

Figure 4.7. Chord rotation vs. axial force ratio curves of Model 7

4.1.8. 40x30, f_{ck} (30Mpa), f_{yk} (420Mpa), 10/10+1 crosstie

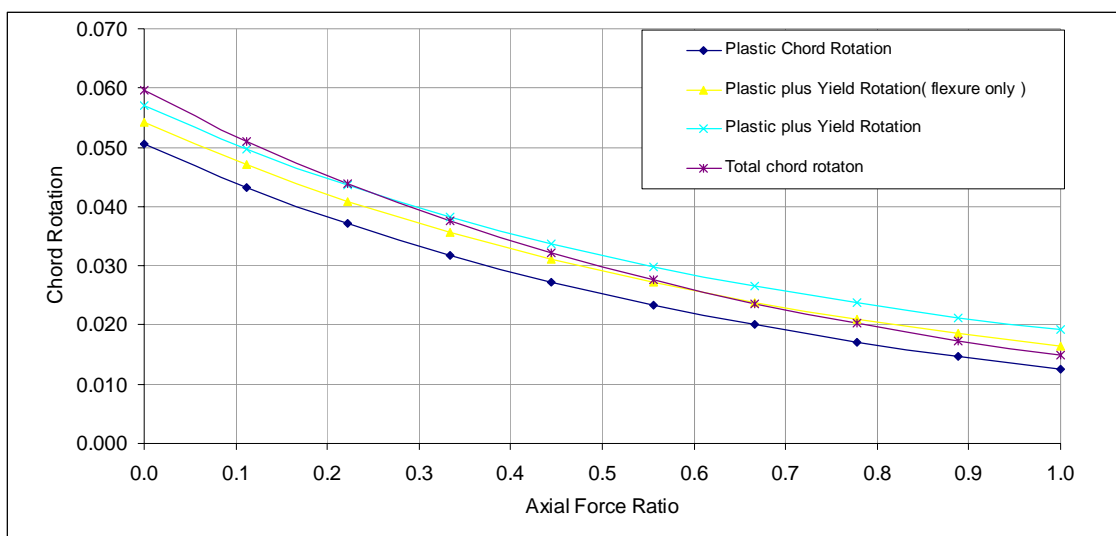

Figure 4.8. Chord rotation vs. axial force ratio curves of Model 8

4.1.9. 40x20, f_{ck} (30Mpa), f_{yk} (420Mpa), 10/10+1 crosstie

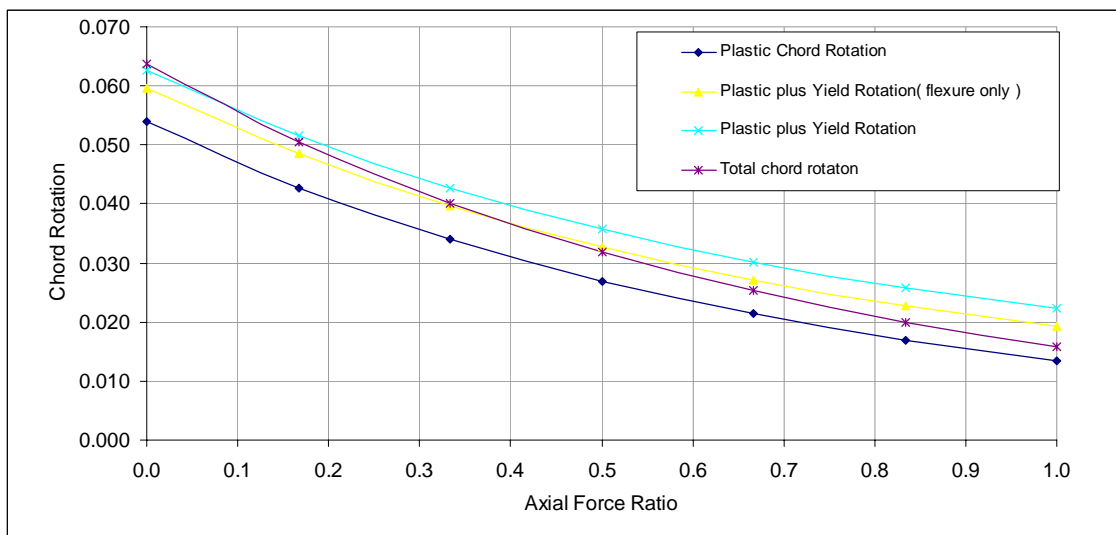

Figure 4.9. Chord rotation vs. axial force ratio curves of Model 9

4.1.10. 40x40, f_{ck} (30Mpa), f_{yk} (420Mpa), 8/20 crosstie

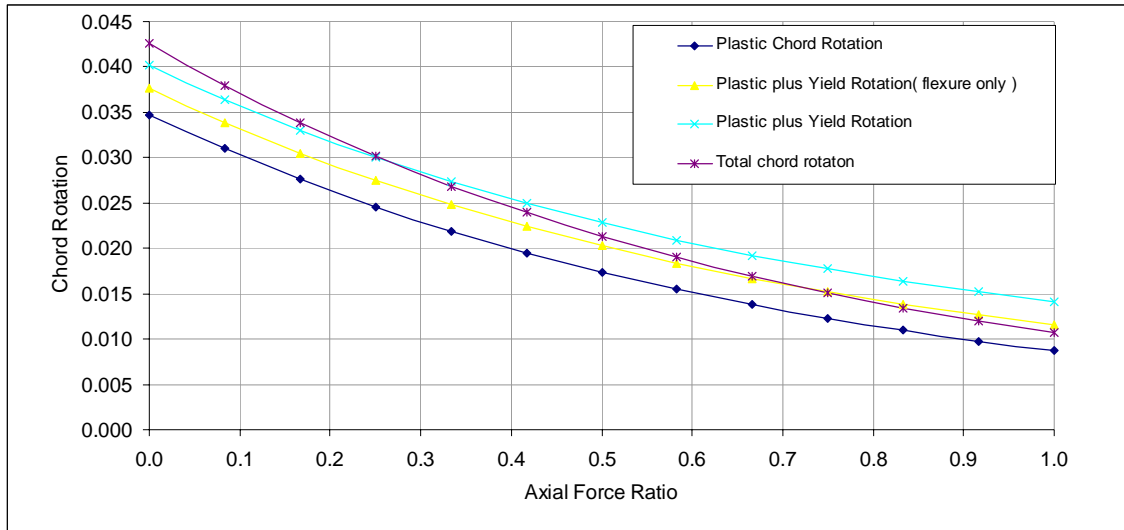

Figure 4.10. Chord rotation vs. axial force ratio curves of Model 10

4.1.11. 40x40, f_{ck} (30Mpa), f_{yk} (420Mpa), 8/30 crosstie

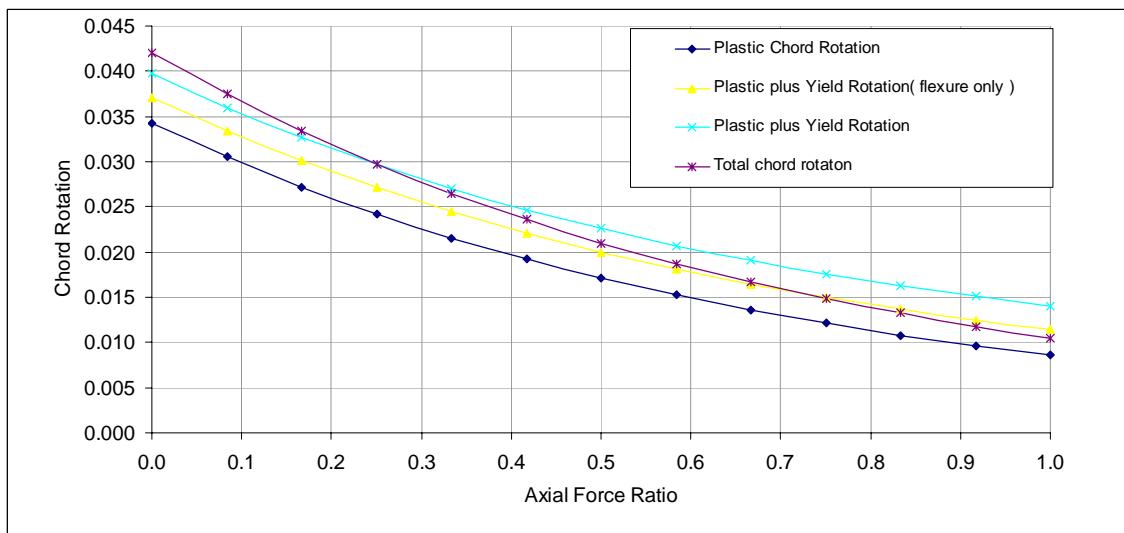

Figure 4.11. Chord rotation vs. axial force ratio curves of Model 11

4.1.12. 40x40, f_{ck} (30Mpa), f_{yk} (420Mpa), 6/30 crosstie

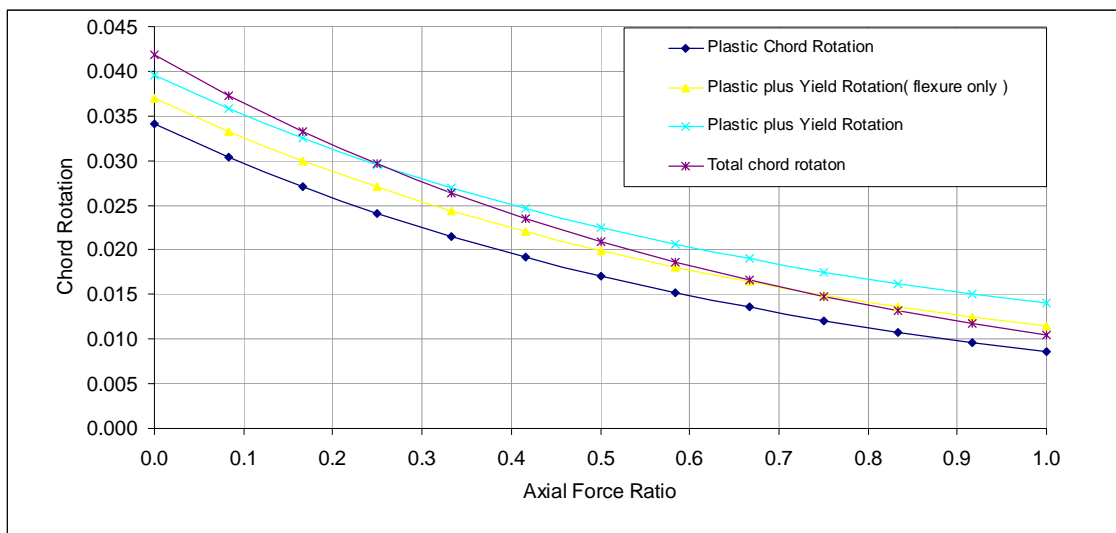

Figure 4.12. Chord rotation vs. axial force ratio curve of Model 12

5. CONCLUSIONS

Performance criteria for assessment or retrofitting of concrete members differs in commonly used codes such as FEMA356 (2000), Eurocode EN1998-3 (2005) and Turkish Seismic Code TSC (2007). Performance evaluations are classified according to *plastic rotation* at FEMA356 (2000), according to *total chord rotation* at EN1998-3 (2005) and according to *material strains* at TSC (2007).

At third chapter 24 different models are used to observe appropriateness of three world-wide used seismic codes. FEMA356 (2000) And TSC (2007) are similar at 17 out of 24 model. EN1998-3 (2005) and TSC (2007) are similar at 8 out of 24 model. FEMA356 (2000) and EN1998-3 (2005) are similar at 13 out of 24 model. Three seismic codes are similar at only 7 out of 24.

At EN1998-3 (2005) confinement term is not so much dominant as TSC (2007). This term is differs from 1 to 1.27 for different confinement properties. We thought confinement must effect plastic chord rotation much more than 1.27.

As a conclusion at fourth chapter, if axial force ratio below 0.5 which is the case in most of the cases, the two chord rotation expressions, first-total chord rotation (2.6) and second-plastic chord rotation (2.1) plus yield chord rotation (4.2) fits each other.

REFERENCES

- EN1992-1-1. (2004). *Eurocode2: Design of concrete structures Part3: General rules and rules for buildings*. Brussels: European Committee for Standardization.
- EN1998-3. (2005). *Eurocode 8: Design of structures for earthquake resistance Part 3: Assesment and retrofitting of buildings*. Brussels: European Commitee for Standardisation.
- FARDIS, M. N. (2007). *Practical implementation of seismic assessment method in Eurocode 8-Part 3, with linear or non linear analysis and deformation -based verification using empirical chord rotation capacity expressions*. Istanbul: Sixth National Conference on Earthquake Engineering.
- FEMA356. (2000). *Prestandard and Commentary for the Seismic Rehabilitation of Buildings*. Washington, D.C.: Federal Emergency Management Agency.
- TSC. (2007). *Specification for Buildings to be Built in Disaster Areas*. Istanbul: Mimistry of Public Works and Settlement Government of Republic of Turkey.