

FOR THE SERVICE

NOT TO BE KEPT IN THIS ROOM

## STRAIT CROSSINGS

*B. Kubilay KAPTAN*

B.S. in Civil Eng., Istanbul Technical University

Submitted to the Institute for Graduate Studies in  
Science and Engineering in partial fulfillment of  
the requirements for the degree of  
Master of Science  
in  
Civil Engineering

Bogazici University Library



39001100120362

14

**Boğaziçi University**

1994

***To my family...***

***B. Kubilay Kaptan***

## ACKNOWLEDGEMENTS

I would like to express my sincere gratitude to my thesis advisor, *Prof. Dr. Semih S. Tezcan*, for his unceasing guidance, inspiration and encouragement that he abundantly supplied throughout the preparation of this Thesis; to *Prof. Dr. Gülay Aşkar* and *Prof. Dr. Nuray Aydınoğlu* for their understanding and useful suggestions in improving the final form of the Thesis; to *Yapı Merkezi* for providing financial support to this research and letting me use the library; to the staff of *Computer Center* for their support during my study at the Computer Center.

# **ABSTRACT**

## **STRAIT CROSSINGS**

The construction of fixed links to cross straits has meant a link of union between lands and people. Strait crossing options are solutions devoted to cope with difficult geography so that the progress on this subject comes as an answer to the "challenge of the geography." Strait crossings require a multidisciplinary approach, not only from the civil engineering view.

Fixed link solutions have a relevant incidence on the environment and affect the social and the economic development of the area; moreover, these works provide mobility as a safety factor.

The decision whether the strait crossings are to be made by fills, bridges, floating bridges, submerged floating bridges, immersed tunnels, immersed floating tunnels or bored tunnels depends on the factors such as; technical feasibility, costs involved, aesthetics and environmental conditions.

By looking at technology of strait crossings over periods of 4,5 or 6 decades one can see and appreciate the developments that inevitably occur in structural forms, construction materials, method of connecting materials, method of structural analysis, construction techniques and aesthetics.

Although the trend is towards the development of fixed links, this is not an option of "all or nothing" and a compromise, a balance has to be achieved between the fixed links and ferries.

That is why it is considered essential to pay special attention to the strait crossings' planning.

## KISA ÖZET

### DENİZ GEÇİŞLERİ

Deniz geçişleri için sabit bağlantıların yapılması kara parçaları ile insanlar arasında birleşme demektir. Deniz geçişi tercihleri zor coğrafik şartlarla başa çıkan öyle çözümlerdeki, bu konudaki ilerlemeler coğrafyanın meydan okumasına cevap olmuştur. Deniz geçişleri sadece inşaat mühendisliği yönünden değil çok yönlü yaklaşıma gerek duyar.

Sabit bağlantıların çevre üzerinde iyileştirici etkiye sahip olup bölgenin sosyal ve ekonomik gelişimini etkilemesinden başka bu çalışmalar güvenlik faktörü olarak akışkanlık sağlar.

Deniz geçişlerinin, dolgu, köprü, dubalı köprü, daldırılmış dubalı köprü, daldırılmış tünel, daldırılmış yüzen tünel veya açılmış tünel olasılıklarından hangisinin kullanılarak yapılacağı kararı, teknik uygunluk, maliyet, estetik, çevresel şartlar gibi faktörlere bağlıdır.

Deniz geçişlerinin 40, 50 veya 60 senelik teknolojisine bakarak; yapısal biçim, inşaat malzemesi, malzeme birleştirme metodları, yapısal analiz metodları, inşaat tekniği ve estetik konularındaki kaçınılmaz olarak meydana gelen gelişim görülebilir.

Her ne kadar eğilim sabit bağlantıların yapılması yönündeyse de bu başka seçenek olmadığı anlamına gelmez; sabit bağlantılar ile arabalı vapurlar arasında bir uzlaşma ve denge sağlanmalıdır.

Bu nedenlerden ötürü, deniz geçişlerinin planlanmasına özel bir önem gösterilmelidir.

# TABLE OF CONTENTS

|   | Page          |
|---|---------------|
| <b>ACKNOWLEDGMENTS</b>                    | <i>iv</i>     |
| <b>ABSTRACT</b>                           | <i>v</i>      |
| <b>KISA ÖZET</b>                          | <i>vi</i>     |
| <b>TABLE OF CONTENTS</b>                  | <i>vii</i>    |
| <b>LIST OF FIGURES</b>                    | <i>xix</i>    |
| <b>LIST OF TABLES</b>                     | <i>xxviii</i> |
| <b>LIST OF SYMBOLS</b>                    | <i>xxix</i>   |
| <br>                                      |               |
| <b>1. INTRODUCTION</b>                    |               |
| 1.1. General Remarks                      | 1             |
| 1.2. Characteristics                      | 1             |
| A. Bridges                                | 2             |
| B. Undersea Tunnels                       | 3             |
| C. Ferries                                | 4             |
| 1.3. Challenges                           | 4             |
| 1.4. Constructibility                     | 4             |
| 1.5. Case Studies                         | 5             |
| <br>                                      |               |
| <b>2. CABLE-STAYED BRIDGES</b>            |               |
| 2.1. Introduction                         | 6             |
| 2.2. Arrangement of the Stay Cables       | 8             |
| A. Radial or Converging System            | 8             |
| B. Harp or Parallel System                | 8             |
| C. Fan or Intermediate System             | 8             |
| D. Star System                            | 8             |
| 2.3. Positions of the Cables in the Space | 10            |
| A. Two Vertical Planes System             | 10            |
| B. Two Inclined Planes System             | 10            |
| C. Single Plane System                    | 10            |
| 2.4. Tower Types                          | 12            |

|   |     |
|---|-----|
| A. Towers Fixed at the Foundation                                   | 12  |
| B. Towers Fixed at the Superstructure                               | 14  |
| C. Hinged Towers  | 14  |
| 2.5. Deck Types   | 14  |
| A. Economy  | 16  |
| 2.6. Main Girders and Trusses                                       | 19  |
| A. Steel Girders  | 19  |
| B. Trusses  | 22  |
| C. Reinforced or Prestressed Concrete Girders                       | 22  |
| D. Structural Advantages  | 24  |
| <br>  |     |
| <b>3. SUSPENSION BRIDGES</b>  |     |
| 3.1. Introduction   | 27  |
| 3.2. Structural Systems   | 27  |
| 3.3. Construction Features  | 35  |
| <br>  |     |
| <b>4. CABLE ANCHORAGE AND CONNECTION IN CABLE SUPPORTED BRIDGES</b> |     |
| 4.1. Introduction   | 38  |
| 4.2. Anchoring of the Single Strand                                 | 38  |
| 4.3. Anchoring of Multi-Strand Cables                               | 43  |
| 4.4. Connection Between Cable and Stiffening Girder                 | 45  |
| 4.5. Connection Between Main Cable and Hanger                       | 50  |
| 4.6. Connection Between Cable and Pylon                             | 56  |
| 4.7. Connection Between Cable and Anchor Block                      | 66  |
| <br>  |     |
| <b>5. ERECTION OF CABLE-SUPPORTED BRIDGES</b>                       |     |
| 5.1. Introduction   | 71  |
| 5.2. Erection of Bridge with Earth Anchored Cable Systems           | 71  |
| 5.3. Erection of Bridges with Self-Anchored Cable Systems           | 73  |
| 5.4. Construction of Pylons   | 82  |
| 5.5. Erection of Cables   | 86  |
| 5.6. Erection of the Stiffening Girder                              | 94  |
| <br>  |     |
| <b>6. ECONOMIC EVALUATION</b>                                       |     |
| 6.1. Introduction   | 102 |
| 6.2. Economic Studies   | 103 |
| 6.3. Economic Comparisons for Pasco-Kennewick Bridge in the U.S.    | 115 |

## **7. FLOATING BRIDGES**

|                          |     |
|--------------------------|-----|
| 7.1. Introduction        | 121 |
| 7.2. Environment         | 121 |
| 7.3. Material Technology | 123 |
| A. Concrete technology   | 123 |
| B. Steel technology      | 124 |
| 7.4. Conclusions         | 125 |

## **8. NEW FEATURES IN BRIDGE DESIGN**

|                                      |     |
|--------------------------------------|-----|
| 8.1. Introduction                    | 127 |
| 8.2. Vertically Tethered Bridges     | 127 |
| A. Introduction                      | 127 |
| B. Support System                    | 129 |
| C. The Bridge Structure              | 129 |
| D. The Load Carrying Principles      | 129 |
| E. The Competitive Advantages        | 131 |
| F. Cost Curve                        | 131 |
| G. Conclusions                       | 131 |
| 8.3. Submerged Floating Tube Bridges | 133 |
| A. Introduction                      | 133 |
| B. Site Dependent Design Parameters  | 133 |
| B.1. Environment                     | 133 |
| B.2. Accidents                       | 135 |
| C. Special Design Solutions          | 136 |
| D. Material Technology               | 138 |
| E. Inspection/Maintenance            | 138 |
| F. Instrumentation                   | 139 |

## **9. SHIP COLLISION WITH BRIDGES**

|  |     |
|--|-----|
| 9.1. Introduction                        | 140 |
| 9.2. Initial Planning                    | 145 |
| A. Sitting of Bridge Structure           | 145 |
| B. Navigation Channel Layout             | 146 |
| C. Overall Bridge Layout                 | 146 |
| D. Vertical clearance                    | 147 |
| E. Horizontal Clearance                  | 147 |
| E.1. Ship domain analysis                | 150 |
| E.2. Manoeuvring simulations with pilots | 154 |

|   |     |
|---|-----|
| E.3. Close encounter analysis                                     | 154 |
| 9.3. Prevention Measures  | 155 |
| A. Aids to Navigation   | 155 |
| B. Vessel Traffic Regulations                                     | 157 |
| C. Vessel Traffic Management Systems                              | 157 |
| 9.4. Protection Measures  | 159 |
| A. Fender Systems   | 159 |
| B. Pile Supported Systems   | 160 |
| C. Dolphin Protection   | 164 |
| D. Artificial Island or Reef Protection                           | 164 |
| E. Floating Protection Systems                                    | 166 |
| <br>  |     |
| <b>10. CASE STUDY NO.1:    <i>SKARNSUNDET &amp; HELGELAND</i></b> |     |
| <b><i>CABLE-STAYED BRIDGES IN NORWAY</i></b>                      |     |
| 10.1. Introduction  | 169 |
| 10.2. Skarnsundet Bridge  | 169 |
| A. Bridge Superstructure  | 172 |
| B. Towers   | 172 |
| C. Cables   | 172 |
| D. Construction   | 172 |
| E. Cost and Financing   | 178 |
| F. Operation and Maintenance                                      | 178 |
| 10.3. Helgeland Bridge  | 179 |
| A. Bridge Superstructure  | 179 |
| B. Towers   | 179 |
| C. Cables   | 179 |
| D. Construction   | 184 |
| E. Cost and Financing   | 186 |
| F. Finishing and Maintenance                                      | 186 |
| G. Traffic  | 186 |
| 10.4. Conclusions   | 188 |
| <br>  |     |
| <b>11. CASE STUDY NO.2:    <i>AKASHI KAIKYO SUSPENSION</i></b>    |     |
| <b><i>BRIDGE IN JAPAN</i></b>                                     |     |
| 11.1. Introduction  | 190 |
| 11.2. Conditions of Design  | 190 |
| 11.3. Construction of the Main Pier Foundations                   | 192 |
| 11.4. Outline of the Anchorage                                    | 194 |

|  |     |
|--|-----|
| 11.5. Design and Erection of Main Towers         | 194 |
| 11.6. Erection of Cables                         | 194 |
| 11.7. Design and Erection of Suspended Structure | 201 |
| 11.8. Coating for Corrosive Environment          | 201 |

## **12. CASE STUDY NO.3: ASKOY SUSPENSION BRIDGE IN NORWAY**

|                                  |     |
|----------------------------------|-----|
| 12.1. Introduction               | 203 |
| 12.2. Bridge Geometry - General  | 203 |
| 12.3. Bridge Selection           | 207 |
| 12.4. Towers                     | 207 |
| A. Construction                  | 207 |
| B. Design Aspects                | 209 |
| 12.5. Saddles                    | 209 |
| 12.6. Cable Anchorages           | 211 |
| 12.7. Cables                     | 213 |
| A. Cable System                  | 213 |
| B. Cable Installation            | 213 |
| 12.8. Stiffening Girder          | 216 |
| A. Production and Transportation | 217 |
| B. Girder Installation/Erection  | 217 |
| 12.9. Concluding Remarks         | 219 |

## **13. CASE STUDY NO.4: NORMANDIE CABLE-STAYED BRIDGE IN FRANCE**

|                                  |     |
|----------------------------------|-----|
| 13.1. Introduction               | 221 |
| 13.2. Wind Governed Design       | 221 |
| 13.3. Composite Construction     | 225 |
| 13.4. High Performance Concrete  | 226 |
| 13.5. Erection of Access Spans   | 226 |
| 13.6. Erection of the Main Span  | 228 |
| 13.7. A New Generation of Cables | 228 |
| 13.8. Interconnecting Ropes      | 231 |
| 13.9. Concluding Remarks         | 232 |

**14. CASE STUDY NO.5: THE NEW LACEY V. MURROW FLOATING  
BRIDGE IN THE USA**

|                                      |     |
|--------------------------------------|-----|
| 14.1. Introduction                   | 234 |
| 14.2. Lake Washington                | 237 |
| 14.3. The New pontoons               | 237 |
| 14.4. Design Criteria                | 239 |
| 14.5. Structural Design and Analysis | 239 |
| 14.6. High Performance Concrete      | 240 |
| 14.7. Special Features               | 241 |
| 14.8. Construction                   | 241 |
| 14.9. Conclusions                    | 242 |

**15. CASE STUDY NO.6: SALHUS FLOATING BRIDGE  
IN NORWAY**

|  |     |
|--|-----|
| 15.1. Introduction                         | 244 |
| 15.2. The Salhus High Level Bridge         | 244 |
| A. Evaluation of Alternatives              | 247 |
| B. Bridge Beam                             | 248 |
| C. Tower                                   | 248 |
| D. Stays                                   | 253 |
| E. Construction                            | 253 |
| 15.3. Design of the Salhus Floating Bridge | 254 |
| 15.4. Bridge Girder                        | 254 |
| 15.5. Elevated Ramp                        | 258 |
| 15.6. Concrete pontoons                    | 260 |
| 15.7. Connection to Abutments              | 263 |
| 15.8. Abutments                            | 264 |
| 15.9. Instrumentation                      | 266 |
| 15.10. Installation                        | 267 |

**16. IMMERSED TUBE TUNNELS**

|  |     |
|--|-----|
| 16.1. Introduction   | 269 |
| 16.2. Characteristics and Types of Immersed Tube Tunnels                 | 271 |
| A. Concrete Tunnels  | 271 |
| B. Steel Tunnels   | 271 |
| C. Comparison  | 272 |
| D. Tunnel Depth  | 272 |
| 16.3. External Aspects and Conditions Impacting the Construction Methods | 274 |

|  |            |
|--|------------|
| <b>A. Hydraulic</b>  | <b>274</b> |
| <b>A.1. Data-collection methodology</b>                                | <b>274</b> |
| <b>A.2. Current-velocity and the directions</b>                        | <b>276</b> |
| <b>A.3. Specific gravity</b>   | <b>276</b> |
| <b>A.4. Tidal effects</b>  | <b>277</b> |
| <b>A.5. Waves, swell and surf</b>                                      | <b>278</b> |
| <b>A.6. Sedimentation</b>  | <b>278</b> |
| <b>A.7. Other river and/or sea characteristics and obstacles</b>       | <b>279</b> |
| <b>A.8. Hydraulic models</b>   | <b>279</b> |
| <b>B. Meteorological Aspects</b>                                       | <b>279</b> |
| <b>B.1. Data collection-methodology</b>                                | <b>279</b> |
| <b>B.2. Wind</b>   | <b>280</b> |
| <b>B.3. Temperature</b>  | <b>280</b> |
| <b>B.4. Visibility</b>   | <b>280</b> |
| <b>B.5. Other meteorological aspects</b>                               | <b>281</b> |
| <b>C. Shipping/Navigation</b>  | <b>281</b> |
| <b>C.1. Ship movements during the marine activities</b>                | <b>281</b> |
| <b>C.2. Suction caused by ships</b>                                    | <b>282</b> |
| <b>C.3. Navigational depth and clearance requirements</b>              | <b>282</b> |
| <b>D. Soil Investigation</b>   | <b>282</b> |
| <b>D.1. Data collection-methodology</b>                                | <b>282</b> |
| <b>D.2. Trench dredging</b>  | <b>282</b> |
| <b>D.3. Settlement</b>   | <b>283</b> |
| <b>E. Seismic</b>  | <b>283</b> |
| <b>F. Fabrication Sites</b>  | <b>283</b> |
| <b>16.4. Dredging and Related Ecological and Environmental Impacts</b> | <b>284</b> |
| <b>A. Geotechnical, Hydraulic and Environmental Conditions</b>         | <b>285</b> |
| <b>B. Criteria Related to the Trench</b>                               | <b>287</b> |
| <b>C. Evaluation of the Dredging Process, Technical Options</b>        | <b>287</b> |
| <b>D. Selection of the Optimal Solutions</b>                           | <b>289</b> |
| <b>16.5. Construction of the Tunnel Elements</b>                       | <b>290</b> |
| <b>A. Construction of the Tunnel Elements</b>                          | <b>290</b> |
| <b>A.1. Steel option</b>   | <b>290</b> |
| <b>A.2. Concrete option</b>  | <b>292</b> |
| <b>B. Finishing Jetty</b>  | <b>292</b> |
| <b>C. Transport of the Tunnel Elements</b>                             | <b>292</b> |
| <b>D. Immersing</b>  | <b>294</b> |
| <b>D.1. Vertical control of steel tunnel elements</b>                  | <b>294</b> |
| <b>D.2. Vertical control of concrete tunnel elements</b>               | <b>294</b> |

|   |     |
|---|-----|
| D.3. Horizontal control                 | 296 |
| D.4. Other equipment related options    | 298 |
| E. Positioning                          | 298 |
| F. Tunnel Foundation                    | 298 |
| F.1. Screeded gravel bed                | 299 |
| F.2. Sandjetting foundation             | 299 |
| F.3. Sand-flow system                   | 300 |
| F.4. Cleaning of the trench             | 300 |
| 16.6. General Matters                   | 303 |
| A. Quality Control                      | 303 |
| B. Risks                                | 304 |
| B.1. Time schedule                      | 304 |
| B.2. Cost                               | 305 |
| C. Project Management                   | 305 |
| D. Project Finance                      | 306 |
| 16.7. World List of Immersed Tunnels    | 307 |
| A. Rupel Tunnel                         | 307 |
| B. Spijkensisse and Coolhaven Tunnels   | 307 |
| C. Keohsiung Tunnel                     | 312 |
| D. Forth McHenry Tunnel                 | 313 |
| E. Third Elizabeth River Tunnel         | 315 |
| <br>                                    |     |
| <b>17. IMMERSED FLOATING TUNNELS</b>    |     |
| 17.1. Introduction                      | 317 |
| 17.2. Loading Considerations            | 317 |
| 17.3. Tunnel Cross Section              | 318 |
| 17.4. Tube Placing and Joining Methods  | 322 |
| 17.5. Foundation System                 | 323 |
| 17.6. Conclusions                       | 323 |
| <br>                                    |     |
| <b>18. ROCK TUNNELING</b>               |     |
| 18.1. Types of Rock and Rock Structures | 325 |
| 18.2. Bedding and Jointing              | 326 |
| 18.3. Drill-and-Blast Cycle             | 328 |
| A. Drilling                             | 328 |
| B. Charging and Firing                  | 330 |
| 18.4. Support System                    | 330 |
| 18.5. Cavern Storage                    | 332 |

|  |     |
|--|-----|
| 18.6. Ancillary Operations in Rock   | 332 |
| A. Rock Bolting  | 332 |
| B. Sprayed Concrete  | 333 |
| <br>   |     |
| <b>19. CUT AND COVER TUNNELS</b>   |     |
| 19.1. Characteristics  | 334 |
| 19.2. Subaqueous Tunnels   | 335 |
| 19.3. Techniques of Construction   | 337 |
| A. Steel Sheet Piling  | 337 |
| B. Ground Anchors  | 339 |
| C. King Piles  | 339 |
| D. Slurry Trench Walls   | 341 |
| E. Concrete Bored Piles  | 341 |
| F. Walls in Heading  | 342 |
| <br>   |     |
| <b>20. CASE STUDY NO.7:    LIEFKENSHOEK IMMERSSED TUBE<br/>                          TUNNEL IN BELGIUM</b> |     |
| 20.1. Introduction   | 343 |
| 20.2. Location   | 344 |
| 20.3. Scheme of the Concession   | 344 |
| 20.4. Construction Methods   | 347 |
| 20.5. Main Characteristics of the Project  | 348 |
| 20.6. The Construction of the Immersed Part of the Concrete Tunnel   | 350 |
| 20.7. Hydraulic Model Tests  | 352 |
| 20.8. Dredging   | 352 |
| 20.9. Hydro-Meteo Survey   | 354 |
| 20.10. Transport of the Tunnel Units   | 354 |
| 20.11. The Immersing   | 355 |
| 20.12. Joint   | 357 |
| 20.13. Foundation  | 357 |
| 20.14. Finishing of the Tunnel   | 357 |
| 20.15. Service Galleries   | 359 |
| 20.16. Tunnel Ventilation  | 359 |
| <br>   |     |
| <b>21. CASE STUDY NO.8:    GREAT BELT BORED<br/>                          TUNNEL IN DENMARK</b>            |     |
| 21.1. Introduction   | 361 |
| 21.2. Description of the Tunnel Unit   | 361 |

|   |     |
|---|-----|
| 21.3. Geography   | 362 |
| A. Project  | 362 |
| B. Ground Conditions  | 362 |
| 21.4. Ground Investigation                                      | 365 |
| A. Post Tender  | 365 |
| B. Subsea Dewatering Wells                                      | 366 |
| C. Cross Passage Investigations                                 | 366 |
| 21.5. Ground Treatment  | 367 |
| A. Till Areas   | 367 |
| B. Meltwater and Disturbed Areas                                | 367 |
| C. Marl Cross Passages  | 368 |
| 21.6. Monitoring  | 370 |
| A. Water Pressure   | 370 |
| B. Main Tunnel Lining Deformations                              | 370 |
| C. Other Monitoring   | 371 |
| 21.7. Excavation and Support                                    | 371 |
| A. Propping, Safety Door and Opening                            | 371 |
| B. Excavation in the Tills                                      | 372 |
| C. Excavation in the Marls                                      | 373 |
| D. Geotechnical Supervision                                     | 373 |
| 21.8. Permanent Works   | 373 |
| 21.9. Cut-and-Cover Tunnel                                      | 376 |
| 21.10. Portal Structures  | 376 |
| 21.11. . The Ramps  | 378 |
| <br>  |     |
| <b>22. FERRIES</b>  |     |
| 22.1. Introduction  | 379 |
| 22.2. Different Types of Ferries                                | 379 |
| A. Standardization of Ferries                                   | 379 |
| B. Standard Ferry Designs                                       | 380 |
| C. High Speed Light Craft                                       | 381 |
| 22.3. Conclusions   | 381 |
| <br>  |     |
| <b>23. CASE STUDY NO.9: ESKİHİSAR - TOPÇULAR<br/>FERRY LINK</b> |     |
| 23.1. General Remarks   | 384 |

|   |     |
|---|-----|
| <b>24. IZMIT BAY CROSSING</b>   |     |
| 24.1. Introduction  | 392 |
| 24.2. The Project Scope   | 392 |
| A. The Bridge   | 393 |
| A.1. Bridge alignment and geometry                                      | 393 |
| A.2. Marine navigational conditions                                     | 393 |
| A.3. Seismic conditions   | 396 |
| A.4. Geotechnical conditions  | 397 |
| A.5. Wind effects   | 397 |
| A.6. Existing constraints   | 397 |
| A.7. Design and code requirements                                       | 398 |
| A.8. Preferred bridge configuration                                     | 398 |
| B. The Motorway   | 398 |
| <b>25. DESIGN ALTERNATIVES FOR IZMIT BAY CROSSING</b>                   |     |
| 25.1. Introduction  | 399 |
| 25.2. Alternative No.1 - Suspension Bridge                              | 401 |
| 25.3. Q-Free System   | 405 |
| A. The Q-Free Video System  | 405 |
| B. The Q-Free Accounting System   | 405 |
| B.1. Payment  | 407 |
| C. The Highlights of the Q-Free System                                  | 407 |
| 25.4. Alternative No.2 - Cable-Stayed Bridge                            | 408 |
| 25.5. Alternative No.3 - Hybrid Bridge                                  | 413 |
| <b>26. LOAN PAYMENT ANALYSIS OF THE IZMIT BAY CROSSING</b>              |     |
| 26.1. Preliminary Cost Estimate of the Alternatives                     | 420 |
| 26.2. Traffic Forecast  | 421 |
| 26.3. Loan Payment Analysis   | 421 |
| 26.4. Conclusions   | 429 |
| <b>27. CONCLUSIONS</b>  |     |
| 27.1. International Experience  | 430 |
| 27.2. Elements for a methodology to follow for Strait Crossing Planning | 430 |
| A. Study of Territory   | 431 |
| B. selection of Alternatives  | 431 |
| C. Technical Solutions  | 431 |
| D. Economy  | 432 |

|   |            |
|---|------------|
| E. Environment and Aesthetics   | 432        |
| F. Social Considerations  | 433        |
| 27.3. Development of Strait Crossings in Other Regions of the World                             | 433        |
| <br>  |            |
| <b>APPENDIX 1 - LOADS ON BRIDGES</b>  | <b>435</b> |
| A1.1. Dead Loads  | 435        |
| A1.2. Live Loads  | 436        |
| A1.3. Dynamic Effects of Vehicles   | 439        |
| A1.4. Longitudinal Forces   | 440        |
| A1.5. Centrifugal Forces  | 441        |
| A1.6. Wind Loads  | 441        |
| A1.7. Earthquake Forces   | 442        |
| A1.8. Stream Flow Pressure  | 443        |
| A1.9. Floating Ice Pressure   | 444        |
| A1.10. Miscellaneous  | 444        |
| <br>  |            |
| <b>APPENDIX 2 - HISTORICAL AND AESTHETIC PARAMETERS<br/>    IN STRAIT CROSSINGS' EVALUATION</b> | <b>445</b> |
| A2.1. Introduction  | 445        |
| A2.2. Framework   | 446        |
| A2.3. Main Characteristic Items   | 446        |
| A. History  | 447        |
| B. Aesthetics   | 448        |
| A2.4. Practical Examples  | 448        |
| A2.5. Conclusions   | 450        |
| <br>  |            |
| <b>APPENDIX 3 - RECORDS OF COLLISION ACCIDENTS<br/>    IN THE PERIOD 1960-1991</b>              | <b>451</b> |
| <br>  |            |
| <b>REFERENCES</b>   | <b>457</b> |

## LIST OF FIGURES

|  | Page |
|--|------|
| <i>FIGURE 2.1.</i> MAIN COMPONENTS OF A CABLE SUPPORTED BRIDGE   | 7    |
| <i>FIGURE 2.2.</i> SYSTEMS OF CABLE ARRANGEMENT  | 9    |
| <i>FIGURE 2.3.</i> SPACE POSITIONS OF CABLES   | 11   |
| <i>FIGURE 2.4.</i> TOWER TYPES   | 13   |
| <i>FIGURE 2.5.</i> IDEAL ORTOHOTROPIC PLATE  | 17   |
| <i>FIGURE 2.6.</i> ORTOHOTROPIC DECK BRIDGES; OPEN RIBS  | 17   |
| <i>FIGURE 2.7.</i> ORTOHOTROPIC DECK BRIDGES; CLOSED RIBS  | 18   |
| <i>FIGURE 2.8.</i> ECONOMY OF ORTOHOTROPIC AND CONVENTIONAL<br>BRIDGES   | 20   |
| <i>FIGURE 2.9.</i> TYPES OF MAIN GIRDER  | 21   |
| <i>FIGURE 2.10.</i> TYPES OF STIFFENING TRUSS  | 23   |
| <i>FIGURE 2.11.</i> REINFORCED AND PRESTRESSED CONCRETE GIRDER   | 25   |
|  |      |
| <i>FIGURE 3.1.</i> SUSPENSION BRIDGE SYSTEMS   | 28   |
| <i>FIGURE 3.2.</i> SINGLE SPAN SUSPENSION BRIDGE WITH INDEPENDANT<br>APPROACH SPANS OUTSIDE THE PYLON                      | 30   |
| <i>FIGURE 3.3.</i> <i>BOSPHORUS BRIDGE</i> (in meters)   | 30   |
| <i>FIGURE 3.4.</i> THREE SPAN SUSPENSION BRIDGE WITH SHORT SIDE<br>SPANS   | 30   |
| <i>FIGURE 3.5.</i> THREE SPAN SUSPENSION BRIDGE WITH LONG SIDE<br>SPANS  | 31   |
| <i>FIGURE 3.6.</i> THREE SPAN SUSPENSION BRIDGE WITH EXTREME SIDE<br>SPANS   | 31   |
| <i>FIGURE 3.7.</i> SUSPENSION BRIDGE WITH SECONDARY PYLONS AND<br>THE MAIN CABLE CONTINUED TO LOW ANCHOR BLOCKS            | 31   |
| <i>FIGURE 3.8.</i> THREE SPAN SUSPENSION BRIDGE WITH A CENTRAL<br>CLAMP AND A FIXED BEARING ON ONE OF THE ANCHOR<br>BLOCKS | 33   |
| <i>FIGURE 3.9.</i> <i>TANCARVILLE BRIDGE</i> (in meters)   | 33   |
| <i>FIGURE 3.10.</i> THREE SPAN SUSPENSION BRIDGE WITH A CENTRAL<br>CLAMP AND A FIXED BEARING ON ONE OF THE PYLONS          | 33   |

|                     |  |    |
|---------------------|--|----|
| <i>FIGURE 3.11.</i> | <b>CONNECTION BETWEEN THE MAIN CABLE AND THE STIFFENING GIRDER AT MIDSPAN</b>                        | 34 |
| <i>FIGURE 3.12.</i> | <b>SUSPENSION SYSTEM WITH INCLINED HANGERS BETWEEN THE MAIN CABLE AND THE STIFFENING TRUSS</b>       | 36 |
| <i>FIGURE 3.13.</i> | <b>SUSPENSION SYSTEM WITH A HANGER NET BETWEEN THE MAIN CABLE AND THE STIFFENING GIRDER</b>          | 36 |
| <i>FIGURE 3.14.</i> | <b>SELF-ANCHORED SUSPENSION SYSTEM</b>   | 36 |
| <br>                |  |    |
| <i>FIGURE 4.1.</i>  | <b>STRAND SHOE FOR ANCHORING STRANDS ERECTED BY THE AIR-SPINNING METHOD</b>                          | 39 |
| <i>FIGURE 4.2.</i>  | <b>CABLE SOCKET</b>  | 41 |
| <i>FIGURE 4.3.</i>  | <b>SOCKET FOR PARALLEL WIRE STRAND</b>   | 41 |
| <i>FIGURE 4.4.</i>  | <b>HiAm SOCKET</b>   | 41 |
| <i>FIGURE 4.5.</i>  | <b>RECTANGULAR BEARING BLOCK</b>   | 42 |
| <i>FIGURE 4.6.</i>  | <b>ELIMINATION OF ANGULAR CHANGES AT THE SOCKET</b>  | 44 |
| <i>FIGURE 4.7.</i>  | <b>ANCHORAGE OF A MULTI-STRAND CABLE</b>   | 44 |
| <i>FIGURE 4.8.</i>  | <b>ONE-SIDED FLARING OF STRANDS FROM SPLAY SADDLE</b>  | 46 |
| <i>FIGURE 4.9.</i>  | <b>TYPES OF STIFFENING GIRDER SECTIONS ALLOWING A DIRECT CONNECTION TO THE CABLES</b>                | 47 |
| <i>FIGURE 4.10.</i> | <b>TYPES OF STIFFENING GIRDERS GIVING INDIRECT CONNECTION TO THE CABLES</b>                          | 48 |
| <i>FIGURE 4.11.</i> | <b>CONNECTION BETWEEN A LARGE MULTI-STRAND STAY CABLE AND A WIDE MONO-CELLULAR STIFFENING GIRDER</b> | 49 |
| <i>FIGURE 4.12.</i> | <b>CONNECTION BETWEEN MONO-STRAND STAY CABLES AND A WIDE MONO-CELLULAR STIFFENING GIRDER</b>         | 51 |
| <i>FIGURE 4.13.</i> | <b>INCLINED ANCHOR GIRDER</b>  | 52 |
| <i>FIGURE 4.14.</i> | <b>CONNECTION BETWEEN A CENTRAL BOX GIRDER AND MONO-STRAND STAY CABLES</b>                           | 52 |
| <i>FIGURE 4.15.</i> | <b>CABLE BAND</b>  | 54 |
| <i>FIGURE 4.16.</i> | <b>WAISTED BOLT</b>  | 54 |
| <i>FIGURE 4.17.</i> | <b>GROOVED CABLE BAND</b>  | 54 |
| <i>FIGURE 4.18.</i> | <b>HANGERS CONNECTED TO CABLE BAND VIA OPEN SOCKETS</b>  | 55 |
| <i>FIGURE 4.19.</i> | <b>CABLE BAND FOR INCLINED HANGERS</b>   | 57 |
| <i>FIGURE 4.20.</i> | <b>THREE TYPES OF CONNECTION BETWEEN CABLES AND PYLONS</b>   | 58 |
| <i>FIGURE 4.21.</i> | <b>ARRANGEMENT OF CABLE ANCHORS IN A MODIFIED MULTI-CABLE FAN SYSTEM</b>                             | 60 |

|              |   |    |
|--------------|---|----|
| FIGURE 4.22. | THREE SOLUTIONS FOR THE ANCHORING OF MONO-STRAND CABLES TO A CONCRETE PYLON           | 61 |
| FIGURE 4.23. | OVERLAPING OF STAY CABLE ANCHORAGES IN A CONCRETE PYLON                               | 63 |
| FIGURE 4.24. | SADDLE SUPPORTED BY LONGITUDINAL GIRDER INSIDE THE PYLON                              | 64 |
| FIGURE 4.25. | ADDITIONAL STRANDS  | 65 |
| FIGURE 4.26. | CABLE SADDLE  | 65 |
| FIGURE 4.27. | SUSPENSION BRIDGE CABLE SADDLE  | 67 |
| FIGURE 4.28. | FIVE SOLUTIONS FOR THE TRANSMISSION OF STRAND FORCES                                  | 68 |
| FIGURE 4.29. | GRAVITY TYPE ANCHOR BLOCK   | 70 |
| FIGURE 4.30. | MAIN CABLE ANCHORAGE IN ROCK ( <i>Firth of Forth Bridge in Scotland</i> )             | 70 |
| FIGURE 5.1.  | ERECTION FROM MIDSPAN TOWARDS THE PYLONS  | 72 |
| FIGURE 5.2.  | ERECTION FROM THE PYLONS TOWARDS MIDSPAN  | 74 |
| FIGURE 5.3.  | ERECTION ON TEMPORARY SUPPORTS  | 75 |
| FIGURE 5.4.  | ERECTION BY DOUBLE-SIDED FREE CANTILEVERING FROM THE PYLONS                           | 77 |
| FIGURE 5.5.  | ERECTION BY ONE-SIDED FREE CANTILEVERING OF THE MAIN SPAN                             | 79 |
| FIGURE 5.6.  | ERECTION PROCEDURE FOR A CABLE STAYED BRIDGE  | 81 |
| FIGURE 5.7.  | ERECTION PROCEDURE FOR A CABLE NET BRIDGE   | 83 |
| FIGURE 5.8.  | BRACING CABLES OF THE <i>LITTLE BELT BRIDGE, DENMARK</i> (in meters)                  | 85 |
| FIGURE 5.9.  | PROPOSED ARRANGEMENT BRACING CABLES OF THE <i>GREAT BELT BRIDGE</i> PROJECT           | 85 |
| FIGURE 5.10. | THE AIR SPINNING METHOD ( <i>Verrazano Narrows Bridge, USA</i> )                      | 87 |
| FIGURE 5.11. | ARRANGEMENT OF STRANDS IN SUSPENSION BRIDGE MAIN CABLES                               | 89 |
| FIGURE 5.12. | PARRALEL-WIRE CABLE SUPPORTED BY TROLLEYS   | 93 |
| FIGURE 5.13. | ARRANGEMENT OF LIFTING STRUTS AS USED IN THE <i>VERRAZANO NARROWS BRIDGE</i>          | 95 |
| FIGURE 5.14. | SCHEMATIC DELINATION OF THE LIFTING ROPE ARRANGEMENT OF THE <i>LITTLE BELT BRIDGE</i> | 97 |
| FIGURE 5.15. | ERECTION OF THE <i>THEODOR HEUSS BRIDGE, GERMANY</i> (in meters)                      | 98 |

|              |  |     |
|--------------|--|-----|
| FIGURE 5.16. | APPLICATION OF A TEMPORARY ERECTION STAY   | 100 |
| FIGURE 5.17. | TEMPORARY CABLE SYSTEM   | 101 |
| FIGURE 6.1.  | BRIDGE TYPE SPAN COMPARISON  | 104 |
| FIGURE 6.2.  | WEIGHT OF STRUCTURAL STEEL FOR ORTHOTROPIC<br>STEEL BRIDGES                                      | 106 |
| FIGURE 6.3.  | <i>KNIEBRÜCKE BRIDGE, GERMANY</i> (in meters)  | 106 |
| FIGURE 6.4.  | WEIGHT OF STRUCTURAL STEEL FOR ORTHOTROPIC<br>STEEL BRIDGES                                      | 107 |
| FIGURE 6.5.  | RELATION OF ASSEMBLY EQUIPMENT AND TOTAL<br>COST TO SPAN OF BRIDGE                               | 109 |
| FIGURE 6.6.  | CONCRETE SUPERSTRUCTURE VOLUME VERSUS SPAN<br>OF BRIDGE  | 110 |
| FIGURE 6.7.  | STEEL SUPERSTRUCTURE VOLUME VERSUS SPAN OF<br>BRIDGE   | 111 |
| FIGURE 6.8.  | PIER CONCRETE VOLUME VERSUS SPAN OF BRIDGE   | 113 |
| FIGURE 6.9.  | COST PER M <sup>2</sup> DECK VERSUS SPAN   | 114 |
| FIGURE 6.10. | PRELIMINARY DESIGN ALTERNATIVES FOR<br><i>PASCO-KENNEWICK BRIDGE</i> (in meters)                 | 116 |
| FIGURE 6.11. | PRELIMINARY DESIGN ALTERNATIVES FOR<br><i>PASCO-KENNEWICK BRIDGE</i> (in meters)                 | 118 |
| FIGURE 7.1.  | FLOATING BRIDGE MODELS   | 122 |
| FIGURE 7.2.  | COST COMPARISON OF TWO ALTERNATIVES  | 126 |
| FIGURE 8.1.  | THE TENSION LEG PLATFORM   | 128 |
| FIGURE 8.2.  | VERTICALLY TETHERED BRIDGE (in meters)   | 130 |
| FIGURE 8.3.  | COST COMPARISON CURVE  | 132 |
| FIGURE 8.4.  | SUBMERGED FLOATING TUBE BRIDGE MODELS  | 134 |
| FIGURE 8.5.  | POSSIBLE CONCEPT FOR SUBMERGED TUBULAR<br>BRIDGE ACROSS <i>HOGSFJORDEN IN NORWAY</i> (in meters) | 137 |
| FIGURE 9.1.  | THE NUMBER OF SERIOUS VESSEL/BRIDGE COLLISION<br>ACCIDENTS PER YEAR IN THE PERIOD 1960-1991      | 141 |
| FIGURE 9.2.  | THE <i>MARACAIBO BRIDGE ACCIDENT, VENEZUELA, 1964</i>  | 142 |
| FIGURE 9.3.  | THE <i>HOPEWELL BRIDGE ACCIDENT, VIRGINIA, USA, 1977</i>   | 142 |
| FIGURE 9.4.  | THE <i>TJÖRN BRIDGE ACCIDENT, SWEDEN, 1980</i>   | 143 |
| FIGURE 9.5.  | THE <i>SUNSHINE SKYWAY BRIDGE ACCIDENT, FLORIDA,<br/>USA, 1980</i>                               | 143 |

|               |  |     |
|---------------|--|-----|
| FIGURE 9.6.   | THE STRANGNAS BRIDGE ACCIDENT, SWEDEN, 1990  | 144 |
| FIGURE 9.7.   | THE CARNAFULI BRIDGE ACCIDENT, BURMA, 1991   | 144 |
| FIGURE 9.8.   | TYPICAL HEIGHTS OF VESSEL CHIMNEYS   | 148 |
| FIGURE 9.9.   | VESSELS AND RESPECTIVE BUMPER AREAS  | 151 |
| FIGURE 9.10.  | HORIZONTAL CLEARANCE REQUIREMENTS FOR<br>IMPORTANT BRIDGES ACCORDING TO THE DOMAIN<br>THEORY | 153 |
| FIGURE 9.11.  | NAVIGATION EQUIPMENT MOUNTED ON THE NAVIGATION<br>SPAN OF THE GREAT BELT WESTERN BRIDGE      | 156 |
| FIGURE 9.12.  | OUTLINE OF VTS SYSTEM COVERING THE WATERS OF<br>THE GREAT BELT IN DENMARK                    | 158 |
| FIGURE 9.13.  | CRUSHABLE CONCRETE BOX FENDER ON THE FRANCIS<br>SCOTT KEY BRIDGE, BALTIMORE, USA (in meters) | 161 |
| FIGURE 9.14.  | FRAMED STEEL FENDER SYSTEM USED FOR PROTECTION<br>OF THE BISAN-NETO BRIDGES, JAPAN           | 162 |
| FIGURE 9.15.  | PILE SUPPORTED PROTECTION SYSTEM FOR THE TOMSO<br>BRIDGE, NORWAY                             | 163 |
| FIGURE 9.16.  | DOLPHIN PROTECTION OF SUNSHINE SKYWAY BRIDGE,<br>FLORIDA, USA (in meters)                    | 165 |
| FIGURE 9.17.  | ARRANGEMENT OF PROTECTION ISLANDS FOR THE<br>ANNACIS ISLAND BRIDGE, VANCOUVER, CANADA        | 167 |
| FIGURE 9.18.  | PROPOSED CABLE NET SYSTEM PROPOSED FOR THE<br>GIBRALTAR BRIDGE                               | 168 |
| FIGURE 10.1.  | ELEVATION (in meters)  | 170 |
| FIGURE 10.2.  | SKANSUNDET BRIDGE, NORWAY  | 171 |
| FIGURE 10.3.  | CROSS SECTION OF THE BRIDGE DECK (in meters)   | 173 |
| FIGURE 10.4.  | MAIN TOWER (in meters)   | 174 |
| FIGURE 10.5.  | CONSTRUCTION PROCEDURE   | 176 |
| FIGURE 10.6.  | ERECTION OF THE GIRDER   | 177 |
| FIGURE 10.7.  | ELEVATION (in meters)  | 180 |
| FIGURE 10.8.  | HELGELAND BRIDGE, NORWAY   | 181 |
| FIGURE 10.9.  | CROSS SECTION OF THE BRIDGE DECK (in meters)   | 182 |
| FIGURE 10.10. | MAIN TOWER (in meters)   | 183 |
| FIGURE 10.11. | SLIPFORM USED FOR SIDESPANS  | 185 |
| FIGURE 10.12. | SLIPFORM USED FOR PYLONS   | 185 |
| FIGURE 10.13. | CROSS STIFFENING OF CABLES   | 187 |
| FIGURE 11.1.  | GENERAL VIEW (in meters)   | 191 |

|                      |   |     |
|----------------------|---|-----|
| <i>FIGURE 11.2.</i>  | <b>MAIN PIER FOUNDATION (in meters)</b>   | 193 |
| <i>FIGURE 11.3.</i>  | <b>ANCHORAGE (in meters)</b>  | 195 |
| <i>FIGURE 11.4.</i>  | <b>MAIN TOWER (in meters)</b>   | 196 |
| <i>FIGURE 11.5.</i>  | <b>TOWER ERECTION PROCEDURE</b>   | 197 |
| <i>FIGURE 11.6.</i>  | <b>TUNED-MASS DAMPER</b>  | 198 |
| <i>FIGURE 11.7.</i>  | <b>CABLE SECTION</b>  | 199 |
| <i>FIGURE 11.8.</i>  | <b>CABLE ERECTION PROCEDURE</b>   | 200 |
| <i>FIGURE 11.9.</i>  | <b>STIFFENING GIRDER ERECTION</b>   | 202 |
|                      |   |     |
| <i>FIGURE 12.1.</i>  | <b>ELEVATION (in meters)</b>  | 204 |
| <i>FIGURE 12.2.</i>  | <b>ASKOY BRIDGE, NORWAY</b>   | 205 |
| <i>FIGURE 12.3.</i>  | <b>CROSS SECTION, MAIN SPAN (in mm)</b>   | 206 |
| <i>FIGURE 12.4.</i>  | <b>NORTH TOWER, ASKOY SIDE (in meters)</b>  | 208 |
| <i>FIGURE 12.5.</i>  | <b>TOWER TOP WITH SADDLE (in meters)</b>  | 210 |
| <i>FIGURE 12.6.</i>  | <b>ANCHORAGE OF MAIN CABLES</b>   | 212 |
| <i>FIGURE 12.7.</i>  | <b>CABLE (in mm)</b>  | 214 |
| <i>FIGURE 12.8.</i>  | <b>INSTALLATION OF CATWALK</b>  | 215 |
| <i>FIGURE 12.9.</i>  | <b>SHIPPING OF THE GIRDER SEGMENTS</b>  | 218 |
| <i>FIGURE 12.10.</i> | <b>LIFTING OF THE GIRDER SEGMENTS</b>   | 218 |
| <i>FIGURE 12.11.</i> | <b>ERECTION OF THE GIRDER</b>   | 220 |
|                      |   |     |
| <i>FIGURE 13.1.</i>  | <b>ELEVATION (in meters)</b>  | 222 |
| <i>FIGURE 13.2.</i>  | <b>NORMANDIE BRIDGE, FRANCE</b>   | 223 |
| <i>FIGURE 13.3.</i>  | <b>CROSS SECTION OF THE ACCESS SPAN DECK (in meters)</b>                            | 224 |
| <i>FIGURE 13.4.</i>  | <b>CROSS SECTION OF THE MAIN SPAN DECK (in meters)</b>                              | 224 |
| <i>FIGURE 13.5.</i>  | <b>ANCHORAGE BOXES, SOUTH PYLON</b>   | 227 |
| <i>FIGURE 13.6.</i>  | <b>INSTALLATION OF AN ANCHORAGE BOX</b>   | 227 |
| <i>FIGURE 13.7.</i>  | <b>CONCRETE ACCESS SPANS LAUNCHED FROM THE<br/>NORTH BANK</b>                       | 229 |
| <i>FIGURE 13.8.</i>  | <b>CONSTRUCTION OF THE DECK AT THE SOUTH PYLON</b>                                  | 229 |
| <i>FIGURE 13.9.</i>  | <b>ERECTION OF THE STEEL GIRDER</b>   | 230 |
|                      |   |     |
| <i>FIGURE 14.1.</i>  | <b>THE NEW LACEY V. MURROW FLOATING BRIDGE</b>                                      | 235 |
| <i>FIGURE 14.2.</i>  | <b>THE I-90 FLOATING BRIDGES: ON THE LEFT IS THE NEW<br/>LACEY V. MURROW BRIDGE</b> | 236 |
| <i>FIGURE 14.3.</i>  | <b>TYPICAL CROSS SECTION (in mm)</b>  | 238 |
| <i>FIGURE 14.4.</i>  | <b>COMPLETED AND FLOATED PONTOON</b>  | 243 |
|                      |   |     |
| <i>FIGURE 15.1.</i>  | <b>PLAN AND ELEVATION (in meters)</b>   | 245 |

|                      |   |     |
|----------------------|---|-----|
| <i>FIGURE 15.2.</i>  | <b>CABLE-STAYED BRIDGE ELEVATION (in meters)</b>                    | 246 |
| <i>FIGURE 15.3.</i>  | <b>MAIN SPAN BRIDGE BEAM (in mm)</b>                                | 249 |
| <i>FIGURE 15.4.</i>  | <b>CONSTRUCTION METHOD (in mm)</b>                                  | 250 |
| <i>FIGURE 15.5.</i>  | <b>ERECTION OF THE CABLE-STAYED SPAN</b>                            | 251 |
| <i>FIGURE 15.6.</i>  | <b>TOWER (in mm)</b>  | 252 |
| <i>FIGURE 15.7.</i>  | <b>SALHUS FLOATING BRIDGE, NORWAY</b>                               | 255 |
| <i>FIGURE 15.8.</i>  | <b>CROSS SECTION (in mm)</b>  | 256 |
| <i>FIGURE 15.9.</i>  | <b>THE STEEL BOX GIRDER</b>   | 257 |
| <i>FIGURE 15.10.</i> | <b>THE ELEVATED RAMP</b>  | 259 |
| <i>FIGURE 15.11.</i> | <b>PONTOONS PLAN AND SECTION (in mm)</b>                            | 261 |
| <i>FIGURE 15.12.</i> | <b>THE PONTOONS</b>   | 262 |
| <i>FIGURE 15.13.</i> | <b>DETAIL OF FLEXIBLE PLATE CONNECTION</b>                          | 265 |
|                      |   |     |
| <i>FIGURE 16.1.</i>  | <b>COMPARATIVE DEPTHS REQUIRED FOR TUNNELS</b>                      | 273 |
| <i>FIGURE 16.2.</i>  | <b>SCHEME OF DATA COLLECTION</b>                                    | 275 |
| <i>FIGURE 16.3.</i>  | <b>TYPICAL CROSS SECTION OF A STEEL TUNNEL</b>                      | 291 |
| <i>FIGURE 16.4.</i>  | <b>PERSPECTIVE VIEW OF JOINT CONNECTION</b>                         | 295 |
| <i>FIGURE 16.5.</i>  | <b>SUBMERGED TUNNEL CONSTRUCTION</b>                                | 297 |
| <i>FIGURE 16.6.</i>  | <b>PRINCIPLE OF THE C&amp;N SANDJET SYSTEM</b>                      | 301 |
| <i>FIGURE 16.7.</i>  | <b>PRINCIPLE OF THE SAND-FLOW SYSTEM</b>                            | 302 |
|                      |   |     |
| <i>FIGURE 17.1.</i>  | <b>IMMERSED FLOATING TUNNEL WITH TENDON CHAMBER</b>                 | 319 |
| <i>FIGURE 17.2.</i>  | <b>TENDONS INSTALLED FROM OUTSIDE</b>                               | 321 |
| <i>FIGURE 17.3.</i>  | <b>LONGITUDINAL ELEVATION</b>                                       | 324 |
|                      |   |     |
| <i>FIGURE 18.1.</i>  | <b>DIP STRATA IN RELATION TO TUNNEL EXCAVATION</b>                  | 327 |
| <i>FIGURE 18.2.</i>  | <b>DRILLING PATTERNS</b>  | 329 |
| <i>FIGURE 18.3.</i>  | <b>INCREASE OF <u>LOAD</u> AS FACE IS ADVANCED</b>                  | 331 |
|                      |   |     |
| <i>FIGURE 19.1.</i>  | <b>SUBAQUEOUS TUNNEL</b>  | 336 |
| <i>FIGURE 19.2.</i>  | <b>SECTION OF SHEET PILING WITH WALLINGS AND<br/>GROUND ANCHORS</b> | 338 |
| <i>FIGURE 19.3.</i>  | <b>KING PILES</b>   | 340 |
|                      |   |     |
| <i>FIGURE 20.1.</i>  | <b>TUNNELS AROUND ANTWERPEN</b>                                     | 345 |
| <i>FIGURE 20.2.</i>  | <b>LONGITUDINAL SECTION (in meters)</b>                             | 349 |
| <i>FIGURE 20.3.</i>  | <b>CROSS SECTION (in mm)</b>  | 351 |
| <i>FIGURE 20.4.</i>  | <b>DREDGING NEAR THE RIVER BANK</b>                                 | 353 |
| <i>FIGURE 20.5.</i>  | <b>THE TUNNEL UNIT AT THE FINISHING JETTY</b>                       | 356 |

|  |            |
|--|------------|
| <b>FIGURE 20.6. MOORING OF THE TUNNEL UNITS</b>                        | <b>356</b> |
| <b>FIGURE 20.7. SANDFLOWING THROUGH THE FLOOR OF THE TUNNEL UNIT</b>   | <b>358</b> |
| <b>FIGURE 21.1. GREAT BELT RING</b>                                    | <b>363</b> |
| <b>FIGURE 21.2. LONGITUDINAL SECTION (in meters)</b>                   | <b>364</b> |
| <b>FIGURE 21.3. WELL POINT ARRAY AT CROSS PASSAGE</b>                  | <b>369</b> |
| <b>FIGURE 21.4. CROSS PASSAGE EXCAVATION</b>                           | <b>374</b> |
| <b>FIGURE 21.5. CROSS PASSAGE COMPLETED</b>                            | <b>375</b> |
| <b>FIGURE 21.6. CUT AND COVER TUNNELS (in meters)</b>                  | <b>377</b> |
| <b>FIGURE 21.7. TUNNELS AT PORTAL (in meters)</b>                      | <b>377</b> |
| <b>FIGURE 22.1. CARGO CAPACITY AND UNIT LOAD</b>                       | <b>383</b> |
| <b>FIGURE 23.1. NUMBER OF VOYAGES PER YEAR</b>                         | <b>385</b> |
| <b>FIGURE 23.2. NUMBER OF PASSANGERS CARRIED PER YEAR</b>              | <b>386</b> |
| <b>FIGURE 23.3. NUMBER OF CARS CARRIED PER YEAR</b>                    | <b>387</b> |
| <b>FIGURE 23.4. NUMBER OF TRUCKS CARRIED PER YEAR</b>                  | <b>388</b> |
| <b>FIGURE 23.5. NUMBER OF TRUCKS (TIR) CARRIED PER YEAR</b>            | <b>389</b> |
| <b>FIGURE 23.6. NUMBER OF BUSES CARRIED PER YEAR</b>                   | <b>390</b> |
| <b>FIGURE 23.7. NUMBER OF TOTAL VEHICLES CARRIED PER YEAR</b>          | <b>391</b> |
| <b>FIGURE 24.1. IZMIT BAY</b>  | <b>394</b> |
| <b>FIGURE 24.2. WATER DEPTH ALONG THE BRIDGE ALIGNMENT</b>             | <b>395</b> |
| <b>FIGURE 25.1. OVERVIEW OF POSSIBLE LINK VERSIONS</b>                 | <b>400</b> |
| <b>FIGURE 25.2. ELEVATION (in meters)</b>                              | <b>402</b> |
| <b>FIGURE 25.3. CROSS SECTION, MAIN SPAN (in mm)</b>                   | <b>403</b> |
| <b>FIGURE 25.4. NORTH TOWER, KABA BURUN SIDE (in meters)</b>           | <b>404</b> |
| <b>FIGURE 25.5. CROSS SECTION IN REEF, KABA BURUN SIDE (in meters)</b> | <b>404</b> |
| <b>FIGURE 25.6. ANCHOR BLOCK, DIL BURNU SIDE (in meters)</b>           | <b>406</b> |
| <b>FIGURE 25.7. ELEVATION (in meters)</b>                              | <b>409</b> |
| <b>FIGURE 25.8. CROSS SECTION, MAIN SPAN (in mm)</b>                   | <b>410</b> |
| <b>FIGURE 25.9. NORTH TOWER, KABA BURUN SIDE (in meters)</b>           | <b>412</b> |
| <b>FIGURE 25.10. PIER PROTECTION (in meters)</b>                       | <b>414</b> |
| <b>FIGURE 25.11. CROSS SECTION, APPROACH SPANS (in meters)</b>         | <b>415</b> |
| <b>FIGURE 25.12. ELEVATION (in meters)</b>                             | <b>416</b> |
| <b>FIGURE 25.13. CROSS SECTION OF THE ACCESS SPAN DECK (in mm)</b>     | <b>418</b> |
| <b>FIGURE 25.14. CROSS SECTION OF THE MAIN SPAN DECK (in mm)</b>       | <b>418</b> |

**FIGURE 25.15. NORTH TOWER, KABA BURUN SIDE (in mm) 419**

**FIGURE 26.1. TRAFFIC FORECAST 426**

**FIGURE A1.1. AASHTO DESIGN VEHICLE LOADINGS 437**

**FIGURE A1.2. AASHTO DESIGN LANE LOADINGS 438**

## LIST OF TABLES

|   | Page |
|---|------|
| TABLE 2.1. DIMENSIONS OF EXISTING CABLE-STAYED BRIDGE             | 15   |
| TABLE 6.1. PASCO-KENNEWICK BRIDGE - ECONOMIC COMPARISON           | 120  |
| TABLE 9.1. VERTICAL CLEARANCE OF LONG SPAN BRIDGES,<br>WORLD-WIDE | 149  |
| TABLE 10.1. WIND CHARACTERISTICS                                  | 187  |
| TABLE 10.2. TECHNICAL DATA  | 189  |
| TABLE 16.1. WORLD LIST OF IMMERSSED TUBES                         | 308  |
| TABLE 16.2. WORLD LIST OF IMMERSSED TUBES                         | 309  |
| TABLE 16.3. WORLD LIST OF IMMERSSED TUBES                         | 310  |
| TABLE 16.4. WORLD LIST OF IMMERSSED TUBES                         | 311  |
| TABLE 22.1. COMPOSITION OF FERRY FLEET                            | 382  |
| TABLE 26.1. PRELIMINARY COST ESTIMATE OF ALTERNATIVE No.1         | 422  |
| TABLE 26.2. PRELIMINARY COST ESTIMATE OF ALTERNATIVE No.2         | 423  |
| TABLE 26.3. PRELIMINARY COST ESTIMATE OF ALTERNATIVE No.3         | 424  |
| TABLE 26.4. COST COMPARISON                                       | 425  |
| TABLE 26.5. FORECAST OF AVERAGE DAILY TRAFFIC                     | 427  |
| TABLE 26.6. LOAN PAYMENT SCHEDULE (USD 10 <sup>3</sup> )          | 428  |
| TABLE A2.1. LIST OF IMPORTANT FIXED LINKS                         | 449  |

## LIST OF SYMBOLS

|  |   |
|--|---|
| <b>C -</b>                               | Horizontal Clearance of the Navigation Span |
| <b>D<sub>x</sub>, D<sub>y</sub> -</b>    | General Stiffness terms                     |
| <b>E, E<sub>x</sub>, E<sub>y</sub> -</b> | Material Properties                         |
| <b>G -</b>                               | Material Property                           |
| <b>H -</b>                               | General Stiffness Term                      |
| <b>I, I<sub>x</sub>, I<sub>y</sub> -</b> | Plat Stiffnesses                            |
| <b>K<sub>T</sub> -</b>                   | Torsional Plate Stiffness                   |
| <b>L<sub>D</sub> -</b>                   | Vessel Length                               |
| <b>t -</b>                               | Plate Thickness                             |

# 1. INTRODUCTION

## 1.1. General Remarks

Strait crossings present a technical challenge to designers and constructors. That challenge can only be met by engineers using the technology of their time, combined with their experience and creativity, supported by the needs of financing of the society benefiting from the project.

## 1.2. Characteristics

Strait crossings generally have certain natural characteristics that place them in a special class of man-built structures that demands innovative responses. Strait crossing projects are always over or under water.

Strait crossing projects usually carry either vehicles or trains, but occasionally both or rapid transit. If tolls are the basis of financing, then a toll plaza must be provided at some point for each vehicle lane on the structure requiring area for the plaza and additional space for support buildings [1].

A continuing maintenance program is a necessity for long life and safety of the structure. Maintenance facilities, often neglected, should be designed into the structure and should include maintenance buildings for equipment and walkways for inspection.

But the important key element of any strait crossing project is cost of the project and the amount of funding available. The project has a finite cost that must be paid for from resources such as taxes or tolls. A recent trend involves using the financial resources of the private sector as funding for some projects.

As engineers we are trained to reduce the most economical project and that training leads designers to strive for the lowest cost. But lowest cost can lead to neglecting some factors, such as aesthetics and environmental damage. In recent years, the public that eventually pays for the project demands quality in aesthetics and preservation of the environment. Any successful strait crossing project must recognize the importance of these controlling characteristics and address them early in the planning process.

Strait crossing projects can be expressed under three main topics: Bridges, Tunnels and Ferries.

### **A. Bridges**

They are generally high-level, and require long spans to cross navigation channels, with the ever present threat of ship collision with the substructure. The water of straits can be deep with swift currents, but occasionally shallow and slow water will prevail. Many time the location experiences high winds all year and sometimes ice in the water. In some locations, tectonic plate movements can produce large earthquakes that can generate large dynamic inertia forces. If the water is salty, then corrosion is a continuing foe of metal. Daily use by vehicles or trains pound the structure with uninterrupted stress ranges with the consequence of fatigue damage. Loads on bridges are briefly described in *Appendix 1*.

Strait crossings can endure for many centuries and its appearance is therefore "everlasting." Many books and articles have been written on the theory and application of bridge aesthetics. However, a bridge speaks for itself as it is the most noble and honest structure that man constructs. It does not conceal; it displays itself. It displays its form through its arches or suspension system; it displays its material such as steel or concrete; and it displays its use such as vehicle or rail. It soars through space in one continues curve. It sweeps from one side of the water to the other in one continues line. Its supports appear firmly rooted in the water and on land. If properly proportioned, it gives the feeling to the viewer of strength, function, and truth, fulfilling its destiny of serving mankind in its aesthetic statement.

Types of bridges which are included in this work are:

- (a) Cable-stayed bridges;
- (b) Suspension bridges;
- (c) Floating bridges;
- (d) Submerged floating tube bridges;
- (e) Vertically tethered bridges.

Main emphasize is given to cable-stayed, suspension and floating bridges. Although submerged floating tube and vertically tethered bridges are proposed for some cases, they have never constructed up to this time.

## B. Undersea Tunnels

An undersea road tunnel is likely to be considered only if there is a clear need for a fixed transport link and a bridge or causeway is ruled out on grounds of cost, technical viability or environmental impact.

The advantages of undersea road tunnels over other transport links are now widely known and include [2]:

- (a) Minimal environmental impact;
- (b) Minimal visual intrusion;
- (c) Traffic is not affected by weather or seastate;
- (d) Continues operation;
- (e) Shorter crossing time than ferry;
- (f) Lower operating costs than ferry;
- (g) No obstruction to shipping.

Undersea road tunnels also have disadvantages which include:

- (a) Expected higher construction cost;
- (b) Operating costs (ventilation, drainage and lighting) generally higher than for bridge or causeway;
- (c) The cost of an undersea road tunnel must also include the cost of onshore tunneling, whereas the cost of a bridge or causeway may be limited to only the sea crossing;
- (d) Reluctance of some motorists to drive through tunnels, particularly undersea tunnels;
- (e) Perceived higher risk of overrun on construction cost;
- (f) Risk of fire.

The three principal construction methods are boring, cut-and-cover and immersed tunnels.

Boring is excavation from within, with the provision of necessary support and lining. It may be subdivided into soft ground tunneling, where excavation is by hand or mechanical cutters and where immediate support is almost always essential; and rock tunneling, where excavation is usually by drill and blast, but where powerful rock-cutting machines now offer an alternative. In cut-and-cover, trenches are excavated from the surface and the structure is built in trench, with backfill over to restore the surface.

Immersed tunnels are used only for water crossing. Prefabricated tunnel units are built elsewhere and floated to site, where they are sunk and jointed in a trench excavated under water in the river or seabed.

Types of bridges included in this work are:

- (a) Immersed tunnels
- (b) Immersed floating tube tunnels;
- (c) Rock tunnels;
- (d) Cut-and-cover tunnels.

Main emphasize is given on the immersed tunnels. Immersed floating tube tunnels have not been constructed up to this time.

### **C. Ferries**

The ferry is a floating link which is considered as a bottleneck. The increased mobility given to the public with the car, naturally leads to that waiting time and thus, slow crossing. Fairly high ferries create dissatisfaction to the user.

Although there is a demand through for replacing the ferry crossings with fixed crossings (bridges and tunnels), ferry connections may be still an alternative for some cases since they have a very low benefit/cost ratio.

## **1.3. Challenges**

These characteristics by no means complete present to the designer a unique set of challenges as each strait crossing project possesses its own characteristics exclusive to that project. But the designer must rise to the challenge and view them as opportunities. Challenges compel solutions, and solutions can result in efficient, cost-effective, and aesthetically pleasing strait crossings.

## **1.4. Constructibility**

Designers can only solve the unique challenges of a strait crossing using the technology current at the same time. Technology is in a continues state of change with constantly new applications and improvements. The designer does not necessarily perceive technology as a constraint as he does not know that which does not exist.

But one constraint the designer must constantly be aware of is the company who must build the structure - the constructor. Those who specialize as construction contractors must be capable of taking a set of drawings and specifications, interpret what is to be constructed, devise a way to build it , calculate a cost to do so, and then, if winning the project, actually construct the strait crossing. The builder is also constrained by the technology available to him. Cranes have limited lifting capacity, concrete and steel have intrinsic limitations in strength, and the structure must be stable during all phases of erection.

### **1.5. Case Studies**

It is helpful to contemporary engineers to go back and look at historic precedent-setting projects and to study what other engineers faced as challenges as well as to study their solutions. Historical and aesthetic parameters in strait crossings' evaluation are briefly described in *Appendix 2*.

## 2. CABLE-STAYED BRIDGES

### 2.1. Introduction

In the family of bridge systems the cable supported bridges are distinguished by their ability to overcome large spans. Actually cable supported bridges are competitive for the spans in the range from 250 meters to 1500 meters (and beyond), thus covering approximately 5/6 of the present span range [3].

For the vast majority of all cable supported bridges the structural system can be divided into four main components as indicated in *Figure 2.1*:

- (1) Bridge deck;
- (2) Cable system supporting the bridge deck;
- (3) Towers (or pylons) supporting the cable system;
- (4) Anchor blocks (or anchor piers) supporting the cable system vertically or horizontally.

The different types of cable supported bridges are distinctively characterized by the configuration of the cable system. Among those new bridge systems developed in the last two decades in an effort to reduce steel and construction costs, the most outstanding are the so-called "cable-stayed" bridges.

Cable-stiffened bridges present a space system consisting of stiffening girders, transverse and longitudinal bracings, an orthotropic-type deck and supporting parts, such as pylons in compression and inclined cables in tension.

The important characteristics of a such a space-type structure is the full participation of transverse construction in the work of the main longitudinal structure. This means a considerable increase in the moment of inertia of the construction, which permits reducing the depth of the girders and economy in steel.

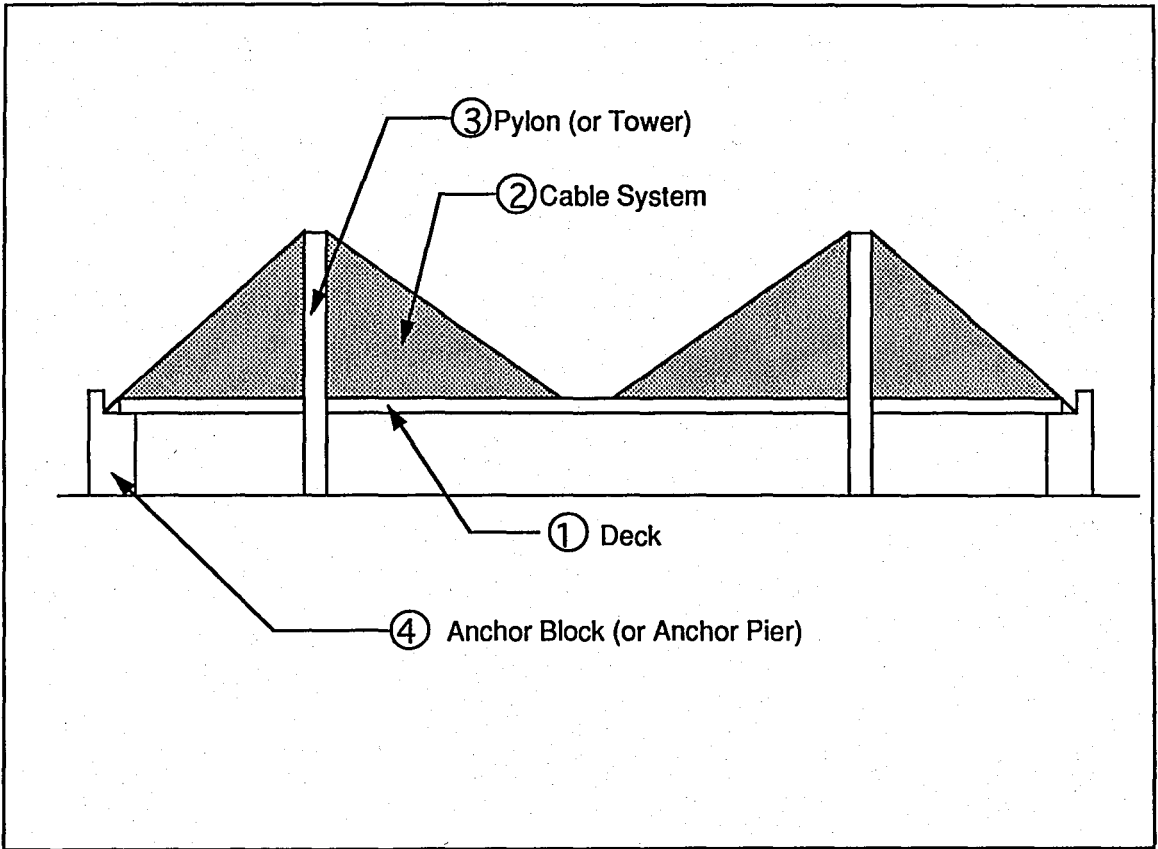

**FIGURE 2.1. MAIN COMPONENTS OF A CABLE SUPPORTED BRIDGE**

## 2.2. Arrangement of the Stay Cables

According to the various longitudinal cable arrangements, cable-stayed bridges could be divided into the four basic systems shown in *Figure 2.2 [4]*.

### A. Radial or Converging System

In this system all cables are leading to the top of the tower. Structurally, this arrangement is perhaps the best, as by taking all cables to the tower top the maximum inclination to the horizontal is achieved and consequently it needs the smallest amount of steel. The cables carry the maximum component of the dead and live load forces, and the axial component of the deck structure is at a minimum

However, where a number of cables are taken to the top of the tower, the cable supports or saddles within the tower may be very congested and a considerable vertical force has to be transferred. Thus the detailing becomes rather complex.

### B. Harp or Parallel System

In this system the cables are connected to the tower at different heights, and placed parallel to each other. This system may be preferred from an aesthetic point of view. However, it causes bending moments in the tower. In addition, it is necessary to study whether the support of the lower cables can be fixed at the tower leg or must be made movable in a horizontal direction.

The harp-shaped cables give an excellent stiffness for the main span, if each cable is anchored to pier on the river banks. The quantity of steel required for a harp-shaped cable arrangement is slightly higher than for a fan-shaped arrangement.

### C. Fan or Intermediate System

The fan or intermediate stay cable arrangement represents a modification of the harp system. The forces of the stays remain small so that single ropes could be used. All ropes have fixed connections in the tower.

### D. Star System

The star pattern is an aesthetically attractive cable arrangement. However, it contradicts the principle that the points of attachment of the cables should be distributed as much as possible along the main girder.







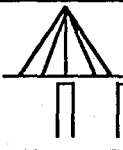

| STAY SYSTEM |                  | SINGLE  | DOUBLE  | TRIPLE   | MULTIPLE  | VARIABLE   |
|-------------|------------------|---|---|--|---|--|
|             |                  | 1   | 2   | 3  | 4   | 5  |
| 1           | BUNDLE OR RADIAL |  |  |   |  |  |
| 2           | HARP OR PARALLEL |  |  |   |  |  |
| 3           | FAN              |   |   |   |  |  |
| 4           | STAR             |   |   |  |   |  |

FIGURE 2.2. SYSTEMS OF CABLE ARRANGEMENT

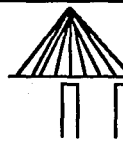
## 2.3. Positions of the Cables in the Space

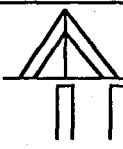
With respect to the various positions in space which may be adopted for the planes in which the cable stays are disposed there are two basic arrangements: two-plane systems and single-plane systems as shown in *Figure 2.3 [4]*.

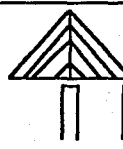
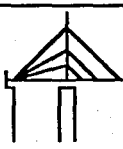
### A. Two Vertical Planes System

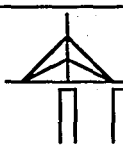
Two alternate layouts may be adopted when using this system: the cable anchorages may be situated outside the deck structure, or they may be built inside the main girders.

The first layout is the better of the two in that no area of the deck surface is obstructed by the presence of cables and towers, as in the second case. There is, however, a disadvantage in that the transverse distance of the cable anchorage points from the webs of the main girders requires substantial cantilevers to be constructed in order to transfer the shears and bending moment into the deck structure. Also the substructure, especially the piers for the towers, has to be longer, because in this case the towers stand apart and outside the cross-section of the bridge.

Where the cables and towers lie within the cross-section of the bridge, the area taken up cannot be utilized as part of the roadway and may be only partly used for the sidewalk. Thus an area of the deck surface is made non-effective and has to be compensated for by increasing the overall width of the deck.

### B. Two Inclined Planes System

In this system cables run from the edges of the bridge deck to a point above the centerline of the bridge on an A-shaped tower. This arrangement can be recommended for very long spans where the A-shaped tower has to be very high and needs the lateral stiffness given by the triangle and the frame action. Joining all cables on the top of this tower has a favorable effect regarding wind oscillations, because it helps to prevent the dangerous torsional movement of the deck.

### C. Single Plane System

Another system is that of bridges with only one vertical plane of stay cables along the middle longitudinal axis of the superstructure. In this case the cables are located in a single vertical strip, which is not being used by any form of traffic. The single plane system creates a lane separation as a natural continuation of the highway approaches to the bridge. This is an economical and aesthetically acceptable solution, providing an

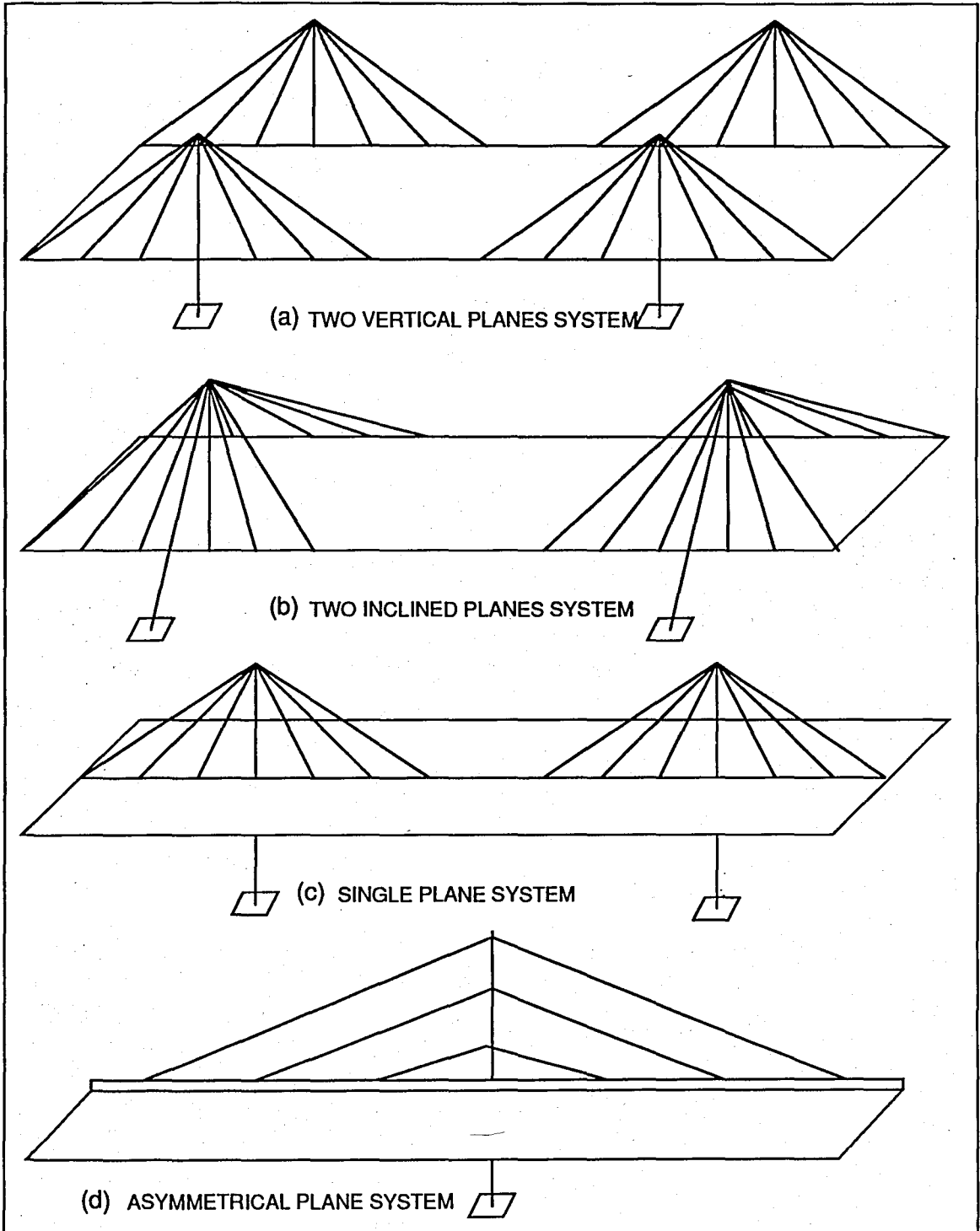

FIGURE 2.3. SPACE POSITIONS OF CABLES

unobstructed view from the bridge. In addition, this system also offers the advantage of relatively small piers, because their size is determined by the width of the main girder. It should be noted that all the possible variations regarding the longitudinal arrangements of the cables used with two plane bridges are also applied to single plane central girder bridges.

## 2.4. Tower Types

The various possible types of tower construction are illustrated in *Figure 2.4* which shows that they may take form of [4]:

- (a) Trapezoidal portal frames;
- (b) Twin towers;
- (c) A-frames;
- (d) Single towers.

Portal type towers were used in the design of early cable-stayed bridges, as in the case of suspension bridges, where the portal type was commonly used to obtain stiffness against the wind load which the cable transfers to the top of the towers. However, later investigation of cable-stayed bridges indicated that the horizontal forces of the cables were in fact, relatively small, so that freely standing tower legs could be used without disadvantage. The inclined stay cables even give a stabilizing restraint force when the top of the tower is moved transversely.

With single towers or twin towers with no cross-member, the tower is stable in the lateral direction as long as the level of the cable anchorages is situated above the level of the base of the tower. In the event of lateral displacement of the top of the tower due to wind forces, the length of the cables is increased and the resulting increase in tension provides a restraining effect of the cables fixed at the saddles or tower anchorages.

There are three different solutions possible regarding the support arrangement of the towers.

### A. Towers Fixed at the Foundation

In this case large bending moments are produced in the tower. The majority of cable-stayed bridges have, however, been built with the towers fixed at the base, and it is stated that the advantage of increased rigidity of the structure thus obtained offsets the disadvantage of the high bending moments in the tower.

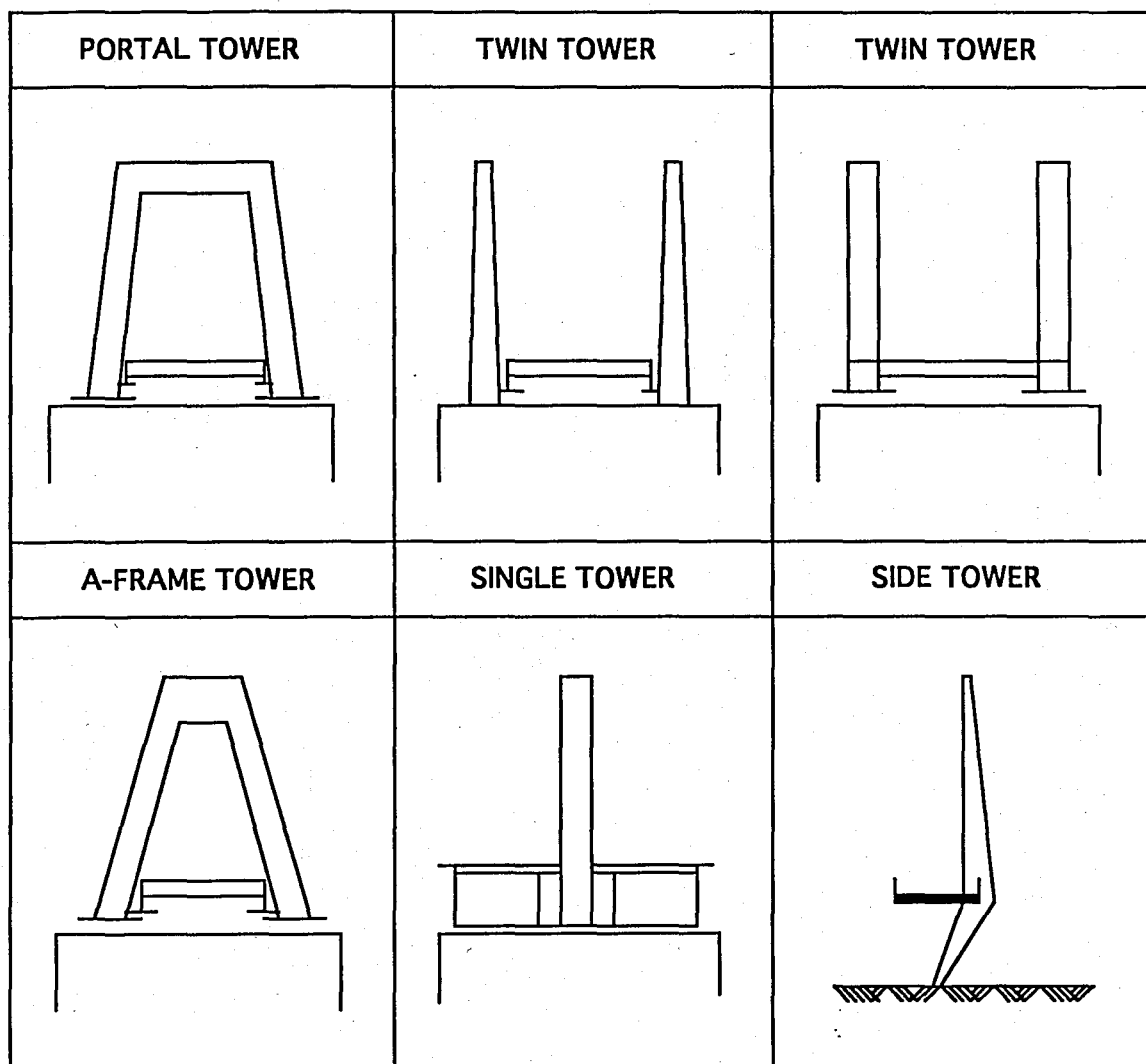

FIGURE 2.4. TOWER TYPES

Towers with fixed legs are relatively flexible, and loading and temperature do not cause significant stresses in the structure. In this case, the main girders pass between the frame legs and are supported on the transverse beam.

### **B. Towers Fixed at the Superstructure**

In this case of the single-box main-bridge system, the towers are generally fixed to the box. With this arrangement it is necessary not only to reinforce the box but to provide strong bearings. The supports also may resist the additional horizontal forces caused by the increased friction forces in the bearings.

### **C. Hinged Towers**

For structural reasons, the towers may be hinged at the base in the longitudinal direction of the bridge. This arrangement reduces the bending moments in the towers and the number of redundants, which simplifies analysis of the overall structure. Also, in cases with bad soil conditions, linear hinges at the tower supports are provided, allowing longitudinal rotation, so that bending moments are not carried by the foundation.

The cable forces and quantity of steel in the cables are influenced by the height of the tower. Making the tower higher reduces the force in the cables, since the cable is at a steeper angle to the girder. However, the cables are longer and the tower is more expensive because of greater height.

The ratio of tower height to length of longest span is given for several bridges in *Table 2.1 [5]*.

## **2.5. Deck Types**

In the search for a more efficient bridge deck, a major advance has been made with the development of the orthotropic steel deck. Most cable-supported bridges have orthotropic decks which differ from one another only as far as the cross-sections of the longitudinal ribs and the spacing of the cross-girders is concerned.

An orthotropic steel deck bridge, generally called an "orthotropic bridge," employs a stiffened steel plate to support the vehicle wheel loads instead of a reinforced concrete slab as used in conventional bridge construction. The word orthotropic is derived from the conjunction of two words, *orthogonal anisotropic*, and means material properties having differences at right angles. The general definition of an orthotropic plate, which has a constant plate thickness  $t$ , can be described by the following material terms [5]:

TABLE 2.1. DIMENSIONS OF EXISTING CABLE-STAYED BRIDGES

| BRIDGE                   | MAXIMUM SPAN (m) | TOWER HEIGHT (m) | RATIO   |
|--------------------------|------------------|------------------|---------|
| St.Nazaire (France)      | 404              | 67               | 0.167   |
| Erskine (Scotland)       | 305              | 38               | 0.125   |
| Kohlbrand (Germany)      | 323              | 98               | 0.304 * |
| Ishikari (Japan)         | 250              | 43               | 0.172   |
| Speyer (Germany)         | 275              | 76               | 0.276 * |
| Sitka Harbor (U.S.A)     | 137              | 30               | 0.222   |
| Hawkshaw (Canada)        | 220              | 34               | 0.155   |
| Oberkassel (Germany)     | 258              | 78               | 0.303   |
| Kniebrücke (Germany)     | 320              | 96               | 0.315   |
| Duisburg (Germany)       | 350              | 50               | 0.143   |
| LeVerkusen (Germany)     | 280              | 45               | 0.161   |
| Karlsruhe (Germany)      | 175              | 46               | 0.263   |
| Bonn-Nord (Germany)      | 280              | 49               | 0.175   |
| Theodore-Heuss (Germany) | 260              | 40               | 0.154   |
| Severin (Germany)        | 301              | 65               | 0.216 * |

\* A - frame towers

$$D_x = E_x \cdot I \quad (2.1)$$

$$D_y = E_y \cdot I \quad (2.2)$$

$$H = G \cdot I \quad (2.3)$$

where  $E_x$ ,  $E_y$ , and  $G$  are material properties and  $I$  is the plate stiffness per unit of width or  $I = 1/12(t^3)$ , as shown in *Figure 2.5*. Such a plate might be fabricated of wood (plywood).

In an orthotropic bridge deck, as shown in *Figure 2.6* and *Figure 2.7*, the deck plate is stiffened in one direction by open ribs or closed ribs. Therefore this type of construction creates a large inertia ( $I$ ) per unit of width at right angles to the stiffeners than it does on a section that is parallel to the stiffeners. Thus the general stiffness equations can be written as

$$D_x = EI_x \quad (2.4)$$

$$D_y = EI_y \quad (2.5)$$

$$H = GK_T \quad (2.6)$$

where  $I_x$  and  $I_y$  are the plate stiffnesses (including stiffeners in two directions) and  $K_T$  is the torsional plate stiffness. With these plate stiffnesses known, the behavior of the deck plate interacting with transverse floor beams and main longitudinal girders of the bridge can then be determined.

In designing bridge structures, it is useful to know their general details. A study of existing orthotropic bridges indicates the following trends [5]:

(A) *Open Cellular Decks*

Size of rib : 0.95cm x 20cm to 2.54cm X 30.50cm

Rib spacing : 30.50cm to 40.6cm

Floor-beam spacing : 1.22m to 2.13m

(B) *Closed Cellular Decks*

Cell spacing : 61.00cm to 71.00cm

Size of cell : 30.5cm x 30.5cm x 0.8cm

Floor-beam spacing : 1.22m to 4.57m.

## A. Economy

As mentioned previously, the main advantage of the orthotropic deck is its reduction in dead weight in comparison to the concrete deck. It also has the ability to act compositely with the main girders, floor beams, and stiffeners.

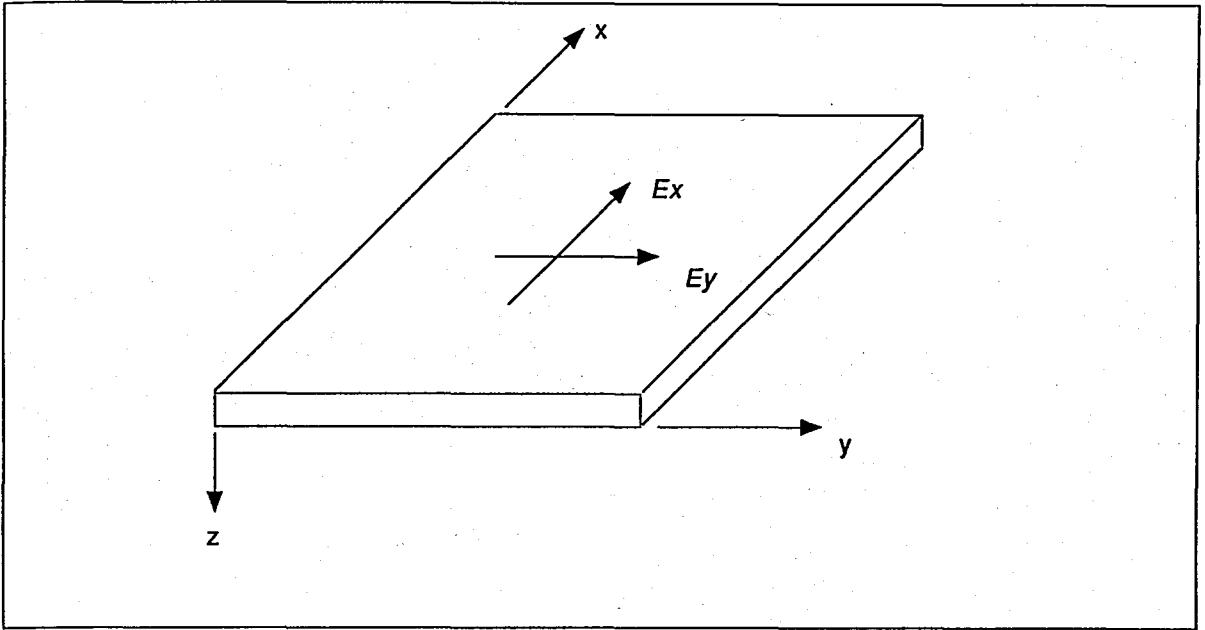

FIGURE 2.5. IDEAL ORTHOTROPIC PLATE

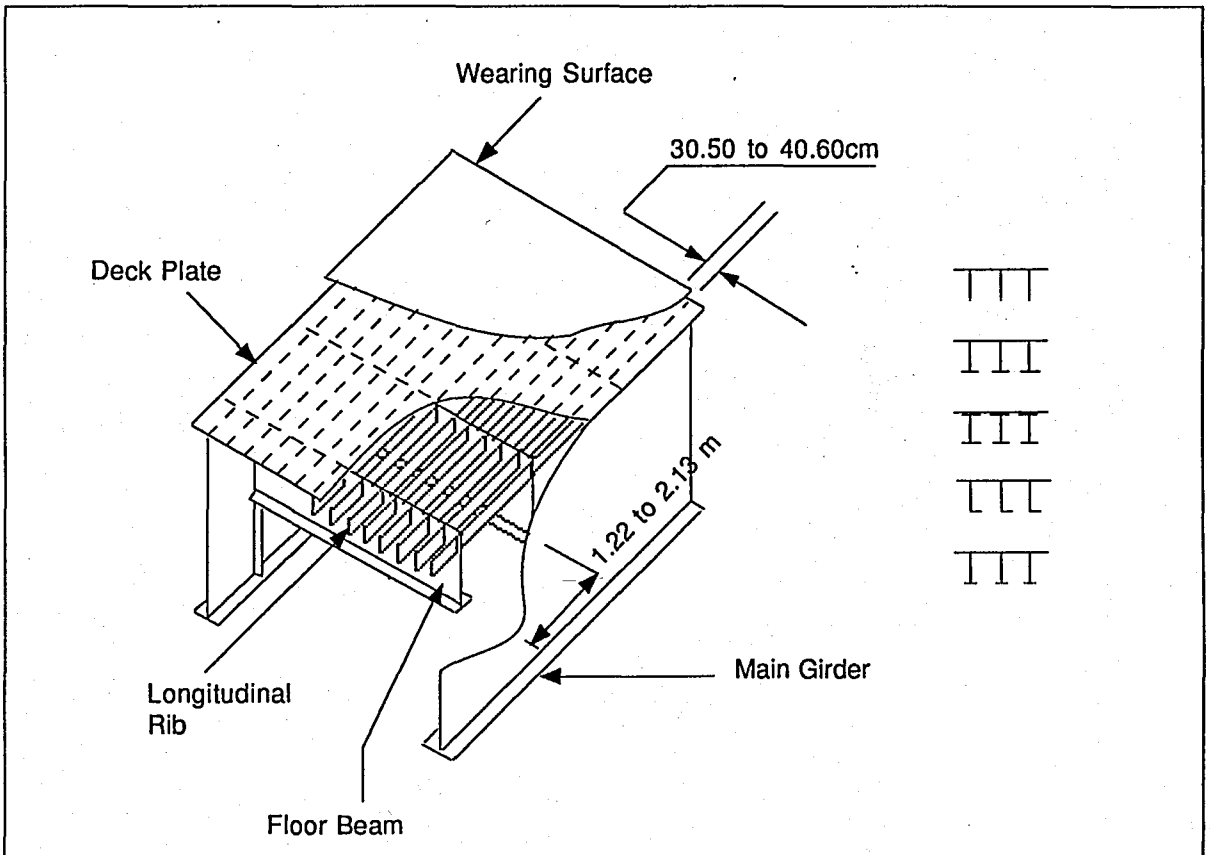
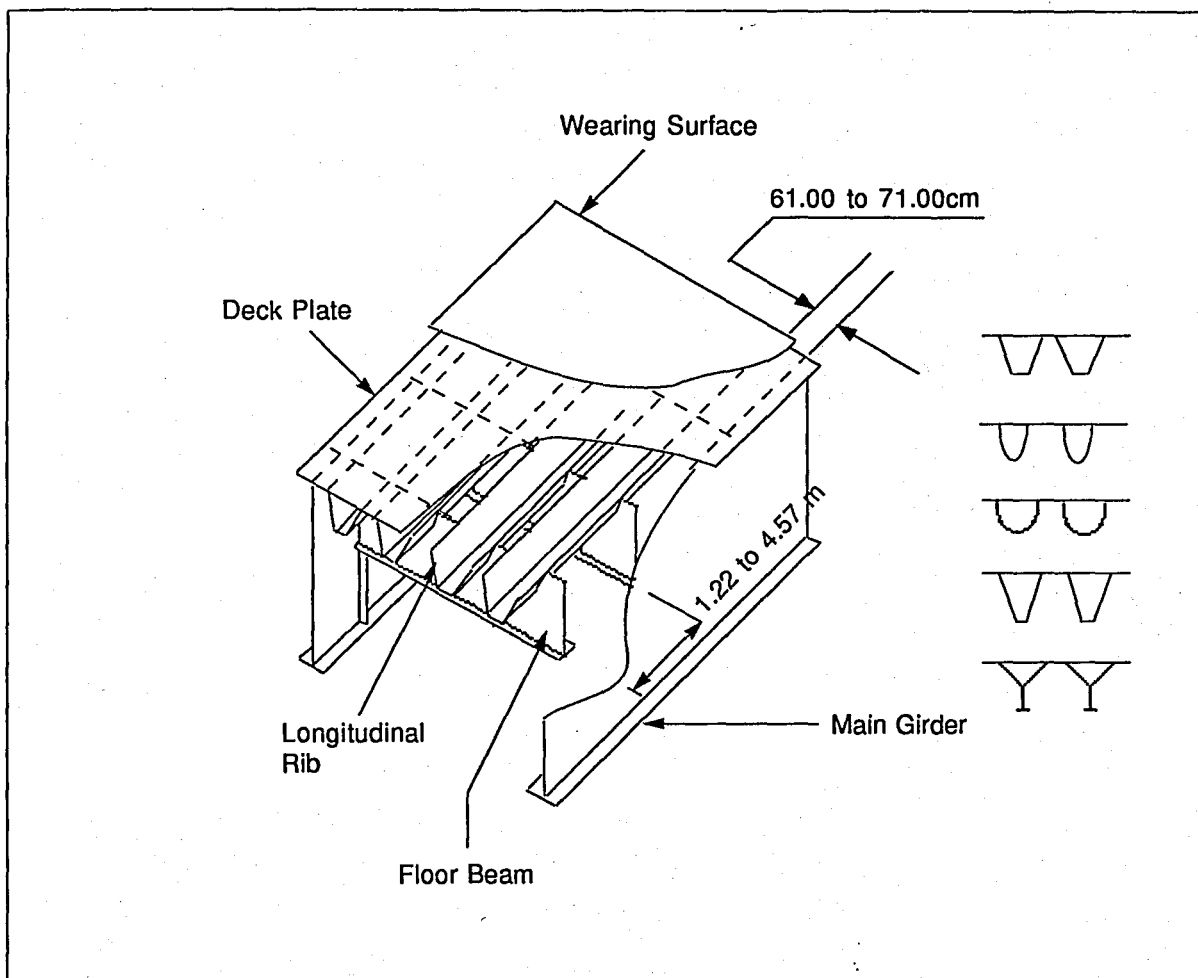

FIGURE 2.6. ORTHOTROPIC DECK BRIDGES; OPEN RIBS



**FIGURE 2.7. ORTHOTROPIC DECK BRIDGES; CLOSED RIBS**

In the long-span bridges, the bending moment due to the dead load comprises a large portion of the design moment. Therefore a reduction in the dead load can significantly affect the economy of the bridge. As the bridge span decreases, the influence of the dead-load moment on the design, and thus economy, also decreases, until conventional bridge designs start to govern. Also to be considered is the fabrication of these steel deck bridges, which require a great deal of welding. A study of the costs of conventional concrete deck bridges and orthotropic deck bridges, has resulted in typical trends as shown in *Figure 2.8*.

This study recommends that orthotropic deck systems with closed ribs will be the most economical. A deck plate of 0.95cm thickness supported at 3.05 meters centers by trapezoidal trough stiffeners 0.64cm thick and spanning between floor beams at 4.57 meters centers provides the minimum recommended deck section. For short and medium span bridges the ribs can be 20.3cm deep, increasing to 30.5cm deep for spans of 183 meters or more. The grade of steel to be used for the deck plate, ribs and floor beam webs, should be normalized to provide for notch toughness and a minimum shaping of 2.77 kilograms.

The trough stiffeners should pass through notches in the floor beam webs and field splices should be all welded and predominantly in the longitudinal direction. Fatigue will not be a governing design consideration and radiographic inspection should be kept to the minimum which would be necessary to secure good workmanship.

## 2.6. Main Girders and Trusses

The following three basic types of main girders or trusses are presently being used for cable-stayed bridges [4]:

### A. Steel Girders

Bridges built with solid web main girders may be divided into two types: those constructed with I-girders and those with one or more enclosed box sections, as shown in *Figure 2.9*.

Plated I-girders with a built-up bottom flange comprising a number of cover plates have been used in some bridges. It is considered that in this way, the required inertia of the section can be made to fit the moment envelope exactly, that no excess steel being used, and thus the minimum weight of the steel is attained. It is felt, however, that this arrangement does not necessarily produce the most economical solution.

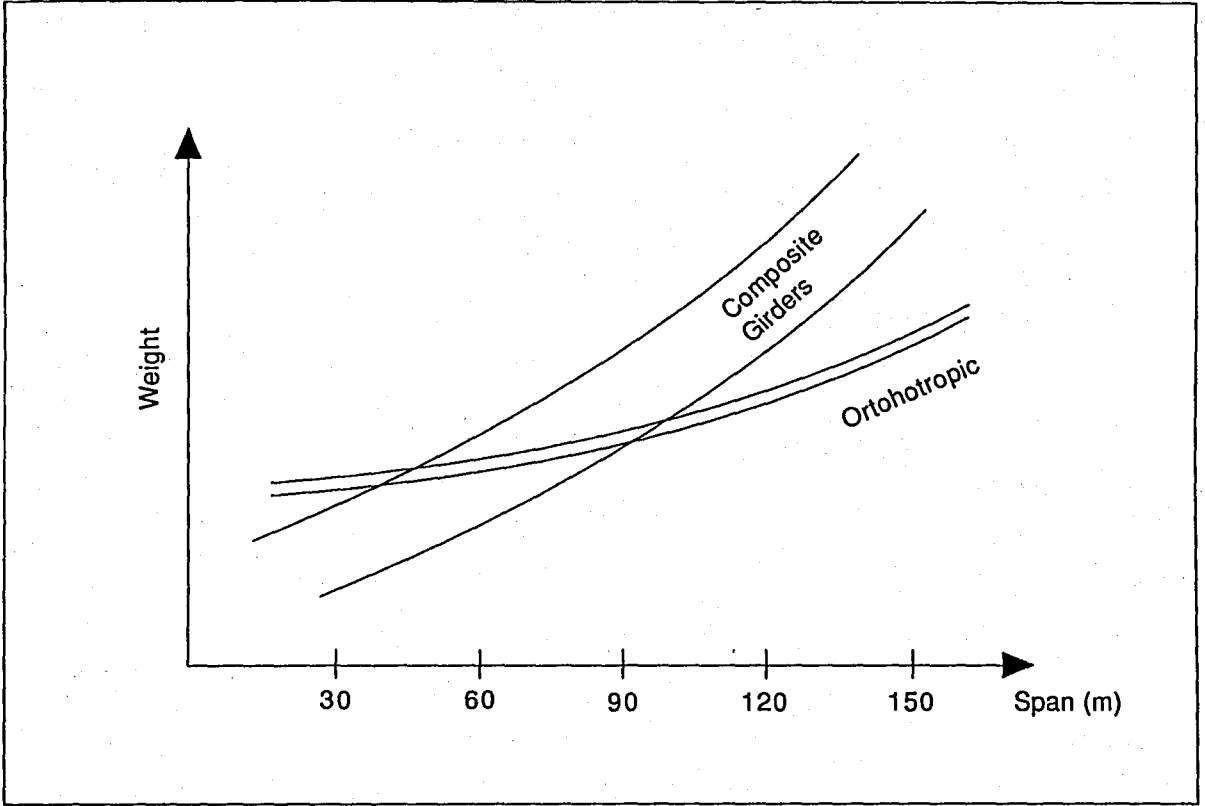

FIGURE 2.8. ECONOMY OF ORTOHOTROPIC AND CONVENTIONAL BRIDGES





| TYPES OF MAIN GIRDER  |  |
|---|--|
| ARRANGEMENT   | DECK CROSS-SECTIONS  |
| Twin<br>I<br>Girder   |    |
| Single<br>Rectangular<br>Box Girder                         |    |
| Central Box Girder<br>and Side Single<br>Web Girders        |    |
| Single Twin<br>Cellular<br>Box Girder and<br>Sloping Struts |  |
| Single<br>Trapezoidal<br>Box Girder                         |  |
| Twin<br>Rectangular<br>Box Girder                           |  |
| Twin<br>Trapezoidal<br>Box Girder                           |  |

FIGURE 2.9. TYPES OF MAIN GIRDER

Box girders in comparison often have portions of their span where a certain minimum plate thickness has to be maintained to prevent local buckling and to provide protection from corrosion, even though the desired inertia does not require such thickness. They do, however, have the great advantage of simplicity of fabrication in comparison to plate I-girders, and most important, a standard section with only the plate thickness varying can be produced in series, which significantly reduces fabrication costs. Also, the inside surfaces are not exposed to the atmosphere, and thus initial protective treatment and later maintenance costs are reduced.

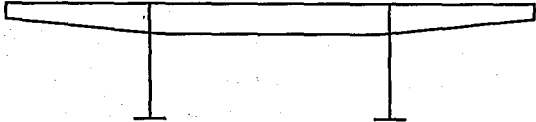
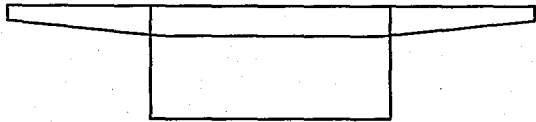
Box girders may be rectangular or trapezoidal in form, i.e. with web plates vertical or sloping. The trapezoidal section is often used in order to keep the bottom flange area to the desired size, whilst the support to the deck plate from the webs is provided at an optimum position.

Although fabrication costs of the inclined web plates are higher, an overall saving can often be achieved. Both plate girder and box section main girders are used for cable-stayed bridges, but it is felt that box sections have a further advantage due to their better torsional stiffness. Unsymmetrical live loading and wind forces can produce high torsional moments and box sections are inherently better suited to carry this type of loading and therefore reduce torsional rotations in the deck.

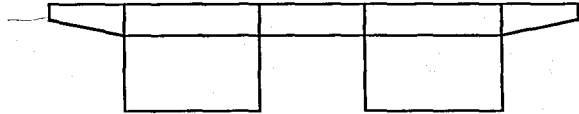
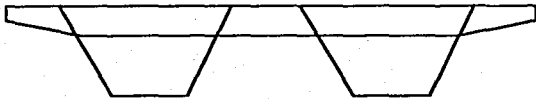
## **B. Trusses**

During the last decade trusses have rarely been used in the construction of cable-stayed bridges. Compared to solid web girders, trusses present an unfavorable visual appearance; they require a great deal of fabrication and maintenance, and protection against corrosion is difficult. Thus, except in special circumstances, a solid web girder is more satisfactory both from an economical and aesthetic viewpoint.

However, trusses may be used instead of girders for aerodynamical reasons. Also, in the case of combined highway and railroad traffic, when usually double deck structures are used, trusses should be provided as the main carrying members of such bridges.. In *Figure 2.10*, typical bridge cross-sections incorporating trusses are shown.

## **C. Reinforced or Prestressed Concrete Girders**

During the last decade a number of cable-stayed bridges have been built with a reinforced or prestressed concrete deck and main girders. These bridges are economical, possess high stiffness and exhibit relatively small deflections. The damping effect of these monolithic structures is very high and vibrations are relatively small. Such outstanding

| TYPE OF BRIDGE |                      | DECK CROSS-SECTION   |
|----------------|----------------------|--|
| 1              | Highway              |  A cross-sectional diagram of a highway bridge deck. The deck is supported by two vertical columns. A stiffening truss is located below the deck, consisting of two vertical members and two diagonal members forming an 'X' shape between the columns.   |
| 2              | Highway And Railroad |  A cross-sectional diagram of a highway and railroad bridge deck. The deck is supported by two vertical columns. A stiffening truss is located below the deck, consisting of two vertical members and two diagonal members forming an 'X' shape between the columns. The deck has a slight upward slope at the ends.    |
| 3              | Highway And Railroad |  A cross-sectional diagram of a highway and railroad bridge deck. The deck is supported by two vertical columns. A stiffening truss is located below the deck, consisting of two vertical members and two diagonal members forming an 'X' shape between the columns. The deck has a slight upward slope at the ends. |
| 4              | Highway And Railroad |  A cross-sectional diagram of a highway and railroad bridge deck. The deck is supported by two vertical columns. A stiffening truss is located below the deck, consisting of two vertical members and two diagonal members forming an 'X' shape between the columns. The deck has a slight upward slope at the ends. |

FIGURE 2.10. TYPES OF STIFFENING TRUSS

structures indicate that this new bridge system possesses many excellent characteristics. Typical cross-sections of this system are shown in *Figure 2.11*.

## 2.7. Structural Advantages

The introduction of the cable-stayed system in bridge engineering has resulted in the creation of new types of structures which possess many excellent characteristics and advantages. Outstanding among these are their structural characteristics, efficiency and wide range of application. The basic structural characteristics and reasons for the rapid development and success of cable-stayed bridges are as outlined below[4].

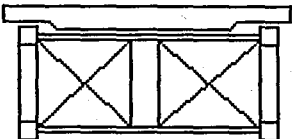
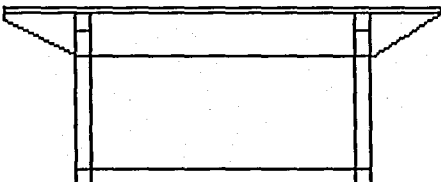
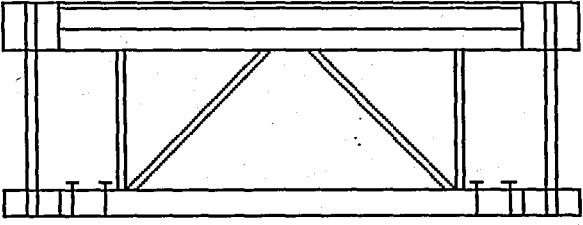
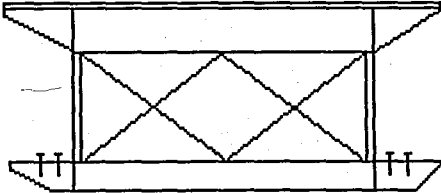
Cable-stayed bridges present a space system, consisting of stiffening girders; steel or concrete deck and supporting parts as towers acting in compression and inclined cables in tension. By their structural behavior cable-stayed systems occupy a middle position between the girder type and suspension type bridges.

The main structural characteristics of this system is the integral action of the stiffening girders and prestressed or post-tensioned inclined cables, which run from the tower tops down to the anchor points at the stiffening girders. Horizontal compressive forces due to the cable action are taken by the girders and no massive anchorages are required. The substructure, therefore, is very economical.

Introduction of the orthotropic system has resulted in the creation of new types of superstructure which can easily carry the horizontal thrust of stay cables with almost no additional material, even for very long spans.

In old types of conventional superstructures the slab, stringers, floor beams and main girders were considered as acting independently. Such superstructures were not suitable for cable-stayed bridges. With the orthotropic type deck, however, the stiffened plate with its large cross-sectional area acts not only as the upper chord of the main girders and of the transverse beams, but also as the horizontal plate girder against wind forces, giving modern bridges much more lateral stiffness than the wind bracings used in old systems. In fact, in orthotropic systems, all elements of the roadway and secondary parts of the superstructure participate in the work of the main bridge system. This results in reduction of the depth of the girders and economy in the steel.

Another structural characteristic of this system is that it is geometrically unchangeable under any load position on the bridge, and all cables are always in a state of tension. This characteristics of the cable-stayed systems permits them to be built from relatively light flexible elements - cables.

| TYPE OF GIRDER |  | DECK<br>CROSS-SECTION  |
|----------------|--|--|
| 1              | Single Box Girder<br>(Wadi Kuf Bridge, Libya)        |     |
| 2              | Twin Box Girders<br>(River Parana Bridge, Argentina) |    |
| 3              | Twin Box Girders<br>(River Waal Bridge, Holland)     |  |
| 4              | Multiple Box Girder<br>(Polcevera Viaduct, Italy)    |  |

FIGURE 2.11. REINFORCED AND PRESTRESSED CONCRETE GIRDER

The important characteristics of such a three-dimensional bridge is the full participation of the transverse structural parts in the work of the main structure in the longitudinal direction. This means a considerable increase in the moment of inertia of the construction, which permits a reduction of the depth of the girders and a consequent saving in steel.

The orthotropic system provides the continuity of the deck structure at the towers and in the center of the main span. The continuity of the bridge superstructure over many spans has many advantages and is actually necessary for a good cable-stayed bridge.

Considering the range of applications in the domain of highway bridges, cable-stayed bridges fill the gap that existed between deck type and suspension bridges. Orthotropic deck plate girders showed superiority over other systems in the case of medium spans. For long spans, however, they required considerable girder depth. The cable-stayed bridge provides a solution to this problem, based on a structural system comprising an orthotropic plate deck and a continuous girder.

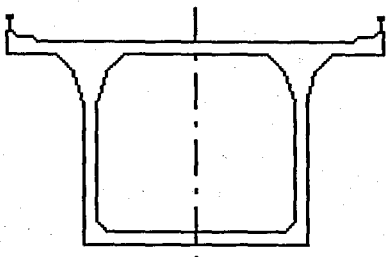
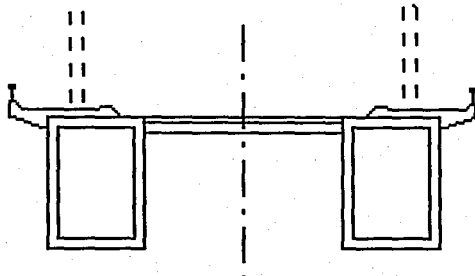
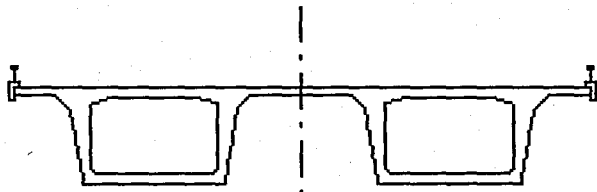
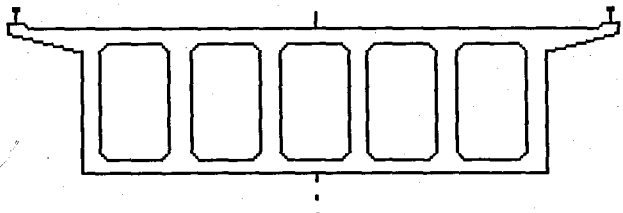
## 3. SUSPENSION BRIDGES

### 3.1. Introduction

The suspension system shown in *Figure 3.1* comprises a parabolic main cable and vertical or slightly inclined hanger cables connecting the stiffening girder to the main cable.

While the suspension bridge in some simple form has been in use for centuries, it has remained for the present generation of engineers to bring it to its highest development and to perfect, probably as far as possible.

### 3.2. Structural Systems

*Figure 3.2* shows a single span suspension bridge with only the main span supported by the cable system, but with the main cable continued as a free cable from the pylon tops to the anchor blocks in some distance from the pylons. Thus, these unsupported cables outside the main span act as anchor cables restraining the pylon top against horizontal displacements [3].

Between the pylons, the bridge system includes a stiffening girder supported by hangers to the main cable, whereas the bridge deck outside the pylons are carried by approach spans acting independently of the cable system.

The system of *Figure 3.2* will generally lead to a structure with favorable deformational characteristics as the pylon tops are efficiently supported horizontally by the anchor cables. However, in case of long span bridges with long anchor cables the sag effect might reduce the efficiency of the horizontal pylon top restraint.

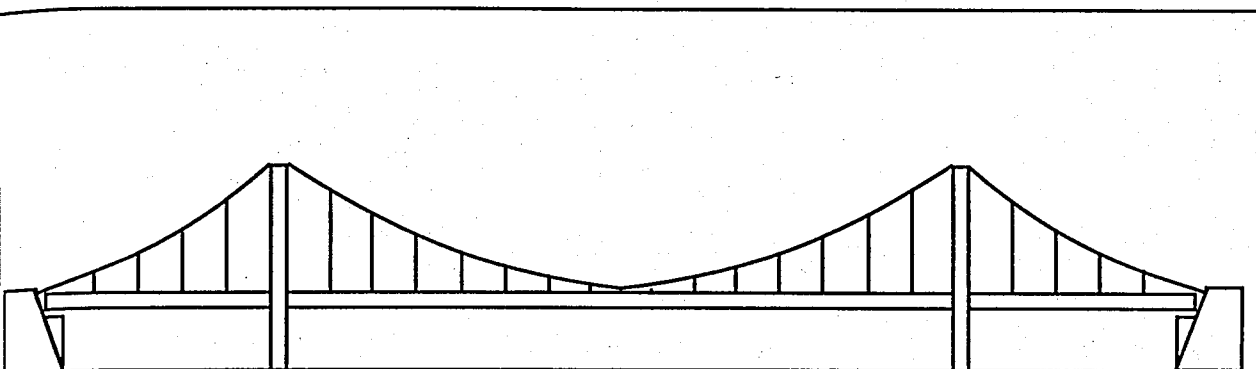

(a) SUSPENSION BRIDGE SYSTEM WITH VERTICAL HANGERS

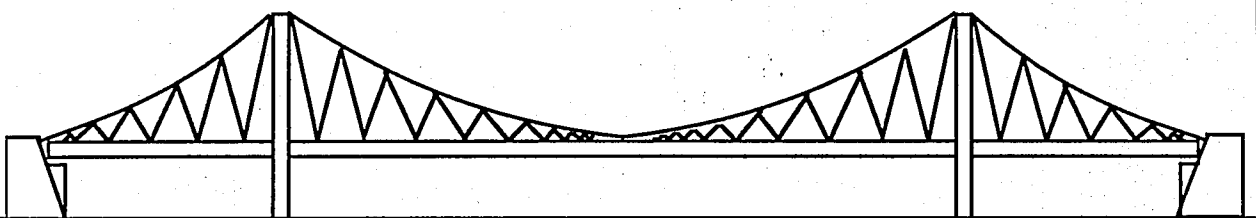

(b) SUSPENSION BRIDGE SYSTEM WITH INCLINED HANGERS

**FIGURE 3.1. SUSPENSION BRIDGE SYSTEMS**

As a prominent example of a single span suspension bridge, *Figure 3.3* shows the Bosphorus Bridge in Turkey. Here the bridge site was especially well suited for the application of the single span solution as the pylons could be placed at the coast line and the independent approach spans on land.

Favorable deformational characteristics are also obtained by the application of relatively short side spans with a length of less than 30 per cent of the main span, as shown in *Figure 3.4*. With short side spans the sag of the side span cable becomes small and this influences favorably the axial stiffness.

In cases where both the main span and the side spans have to be placed above deep water, long side spans with a length of 40 per cent - 50 per cent of the main span are found, as shown in *Figure 3.5*. A side-to-main span ratio of 0.5 probably leads to the most pleasing appearance of the suspension bridge due to the symmetry of the cable system about each pylon. On the other hand, long side spans imply that the cable leading from the anchor block to the pylon top will have a considerable sag, influencing unfavorably the horizontal support of the pylon top. Long side spans will therefore lead to a large flexibility of the main span. Thus, the suspension bridge with long side spans constitutes one of the many examples of the fact that beauty and the structural efficiency do not always go hand in hand.

Extremely long side spans with a length exceeding half of the main span length will lead to a structure as shown in *Figure 3.6*. Here the outer parts of the girder in the side spans have to be supported by short columns to the main cable below. For a conventional suspension bridge system with vertical hanger and slender pylons a system as shown in *Figure 3.6* would lead to very unfavorable deformational characteristic.

In most three-span suspension bridges the main cables are led directly into the anchor blocks at the ends of the side spans. However, in some cases secondary pylons are placed at the ends of the cable supported side spans and the main cables are then continued to lower anchor blocks placed closer to the soil, as illustrated in *Figure 3.7*.

Such an arrangement generally leads to cheaper anchor blocks as the overturning moment from the cable pull is reduced considerably, but at the same time the main cable length is increased. Thus, the quantity of cable steel will be larger and the side span cables will be more flexible.

The arrangement of *Figure 3.7* becomes less attractive if the bridge parts outside the secondary pylons are above navigable waters so that the main cables below the bridge deck could be hit accidentally by ships.

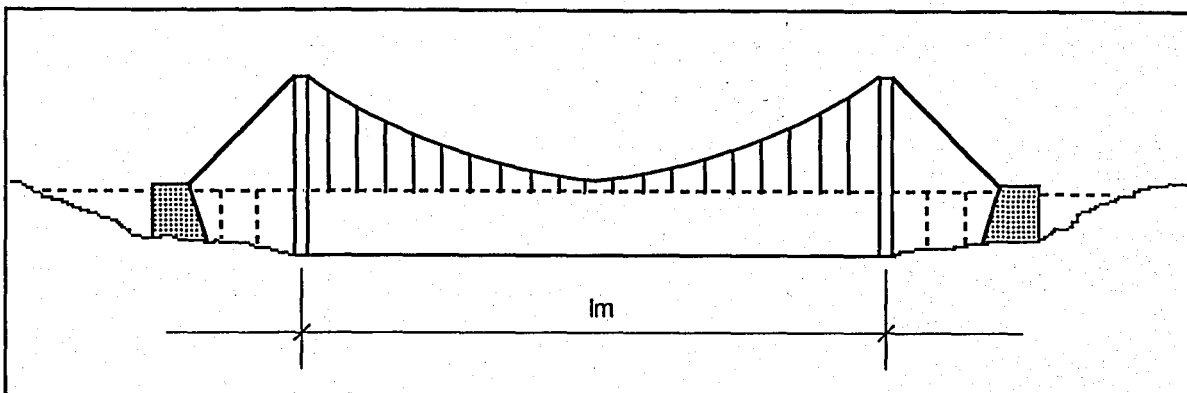

FIGURE 3.2. SINGLE SPAN SUSPENSION BRIDGE WITH INDEPENDENT APPROACH SPANS OUTSIDE THE PYLON

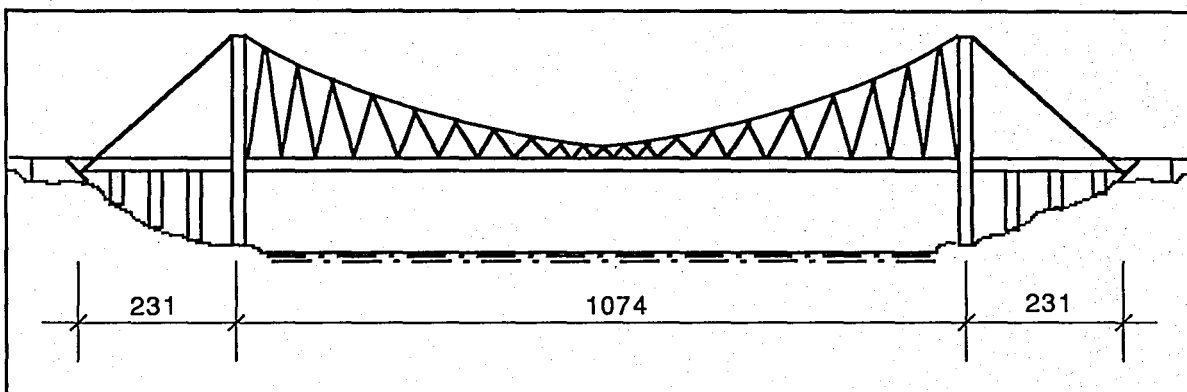

FIGURE 3.3. BOSPHORUS BRIDGE (In meters)

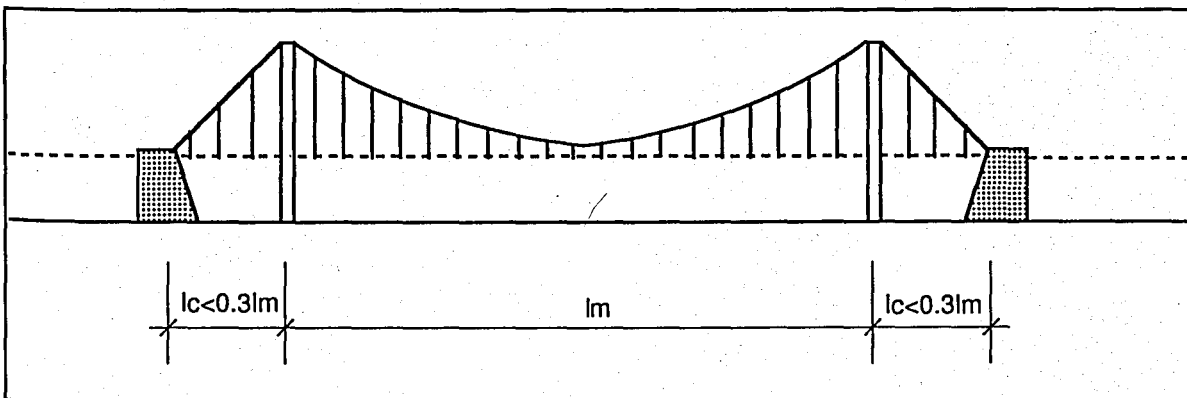

FIGURE 3.4. THREE-SPAN SUSPENSION BRIDGE WITH SHORT SIDE SPANS

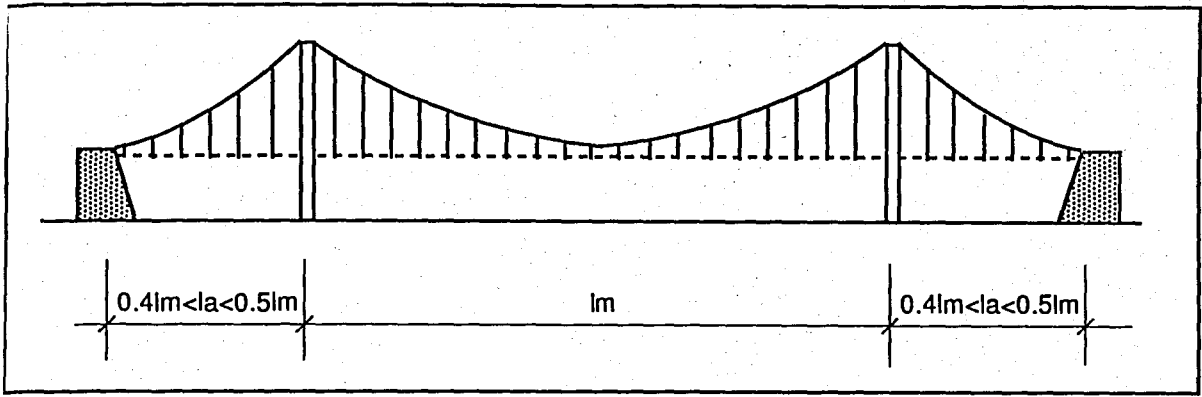

FIGURE 3.5. THREE-SPAN SUSPENSION BRIDGE WITH LONG SIDE SPANS

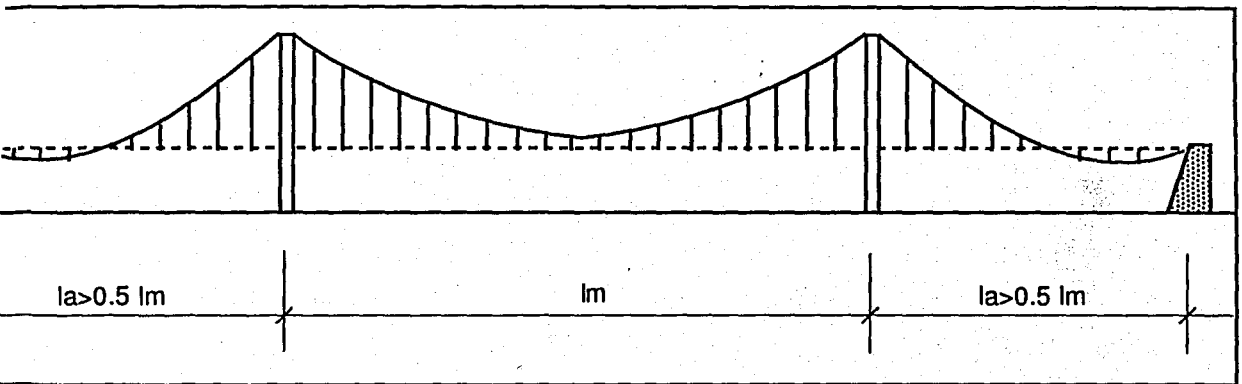

FIGURE 3.6. THREE-SPAN SUSPENSION BRIDGE WITH EXTREME SIDE SPANS

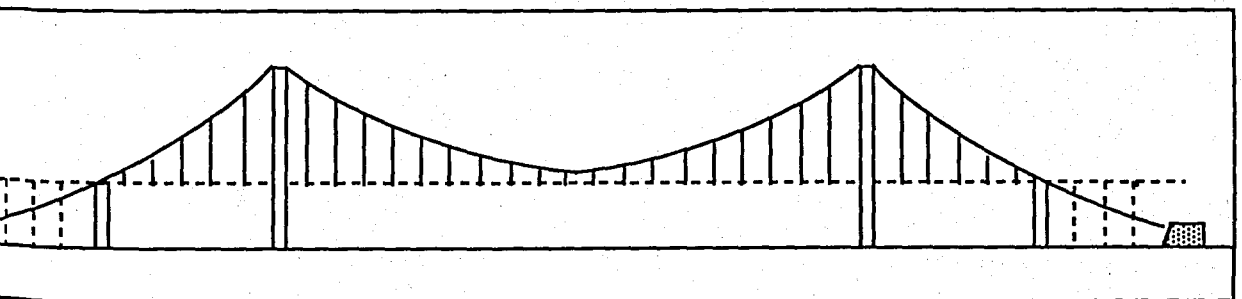

FIGURE 3.7. SUSPENSION BRIDGE WITH SECONDARY PYLONS AND THE MAIN CABLE CONTINUED TO LOW ANCHOR BLOCKS

The application of a central clamp fixed to the stiffening girder has a significant influence in reducing deflections under asymmetric load.

The cable system of a three-span suspension bridge with a central clamp might be arranged as shown in *Figure 3.8*. Here the continuous stiffening girder is supported by a fixed bearing on the left anchor block and by a longitudinally movable bearing on the right anchor block. Due to the rigid connection at mid span (the central clamp) between the main cable and the girder, and in accordance with the definition given earlier this part of the girder should therefore be regarded as a part of the cable system.

The highest efficiency of the central clamp will exist in systems where the pylon tops are well restrained against longitudinal displacements. Thus, a central clamp will be especially attractive in suspension bridges with short side spans.

A structural system similar to that shown in *Figure 3.8* was used for the first time in the Tancarville Bridge across the Seine River as shown in *Figure 3.9*. Here the fixed bearing was arranged on the large anchor block to the right (on the left bank of the river).

With structural system as shown in *Figure 3.8* the central clamp is efficiently restrained longitudinally under varying traffic load conditions, but longitudinal movements of the central clamp will be introduced under temperature changes as the stiffening girder expands or contracts.

As the thermal movements are proportional to the length of expansion, a reduction of the movements will occur if the fixed bearing of the stiffening girder is placed on one of the pylons, as shown in *Figure 3.10*. The feasibility of this solution depends on the intensity of the horizontal forces to be transferred from the stiffening girder, as bending will be induced in the pylon legs and the adjoining pier.

In bridges without a central clamp the main cable is often kept at some distance from the stiffening girder so that the connection between the two structural elements can be established by hangers throughout the span, as indicated in *Figure 3.11 (a)*.

The same position of the cable might also be used in cases where a central clamp is required. In that case the central hanger is substituted by a vertical element with a longitudinal stiffness, as indicated under (b). Finally, the main cable might be led down to the top of the stiffening girder so that the central clamp can be connected directly to the top flange of the girder (c).

In the conventional suspension system with vertical hangers the cable system does not possess any shear strength so that the shear forces created by the external load must be resisted either by the stiffening girder or by a displacement of the main cable.

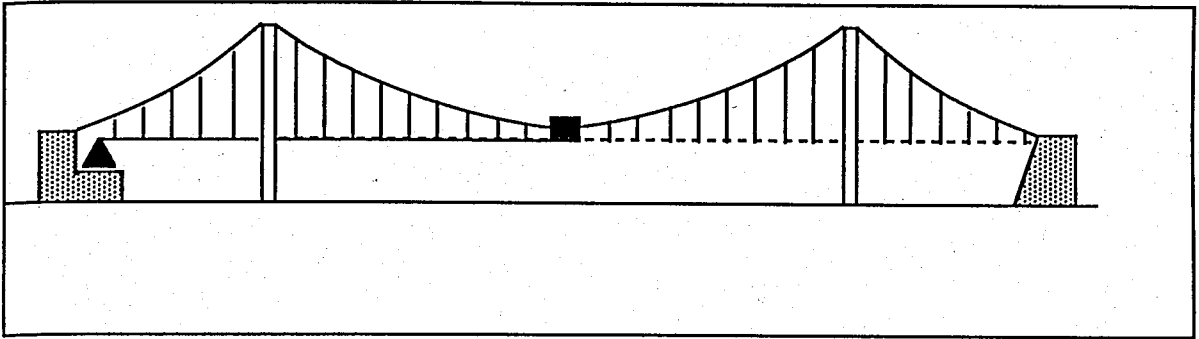

FIGURE 3.8. THREE-SPAN SUSPENSION BRIDGE WITH A CENTRAL CLAMP AND A FIXED BEARING ON ONE OF THE ANCHOR BLOCKS

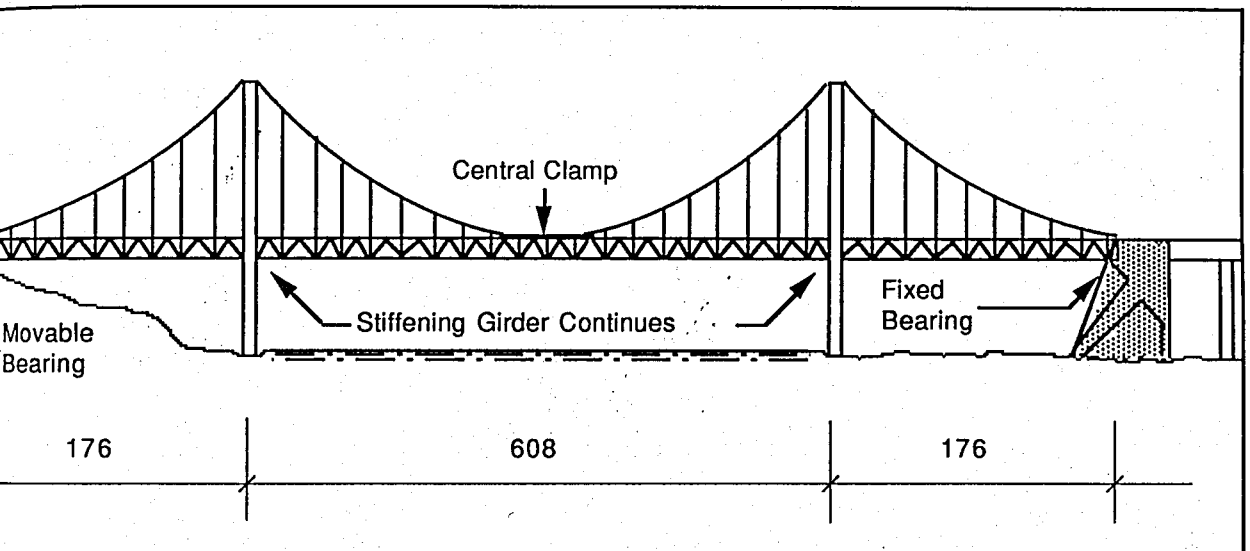

FIGURE 3.9. TANCARVILLE BRIDGE (In meters)

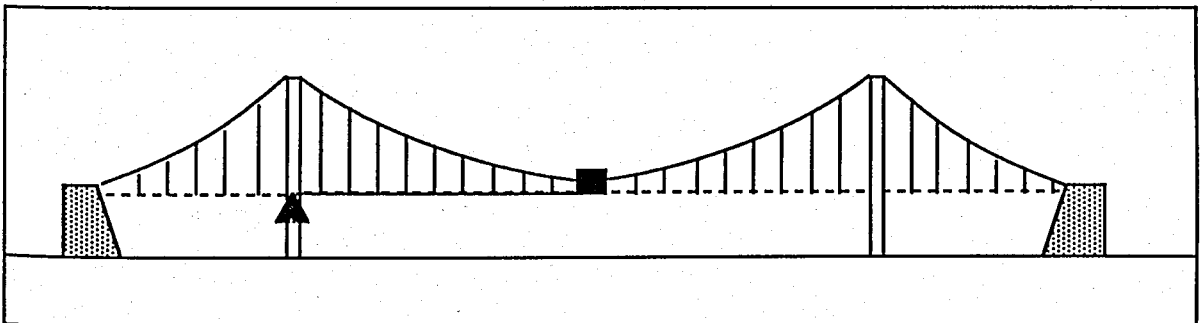
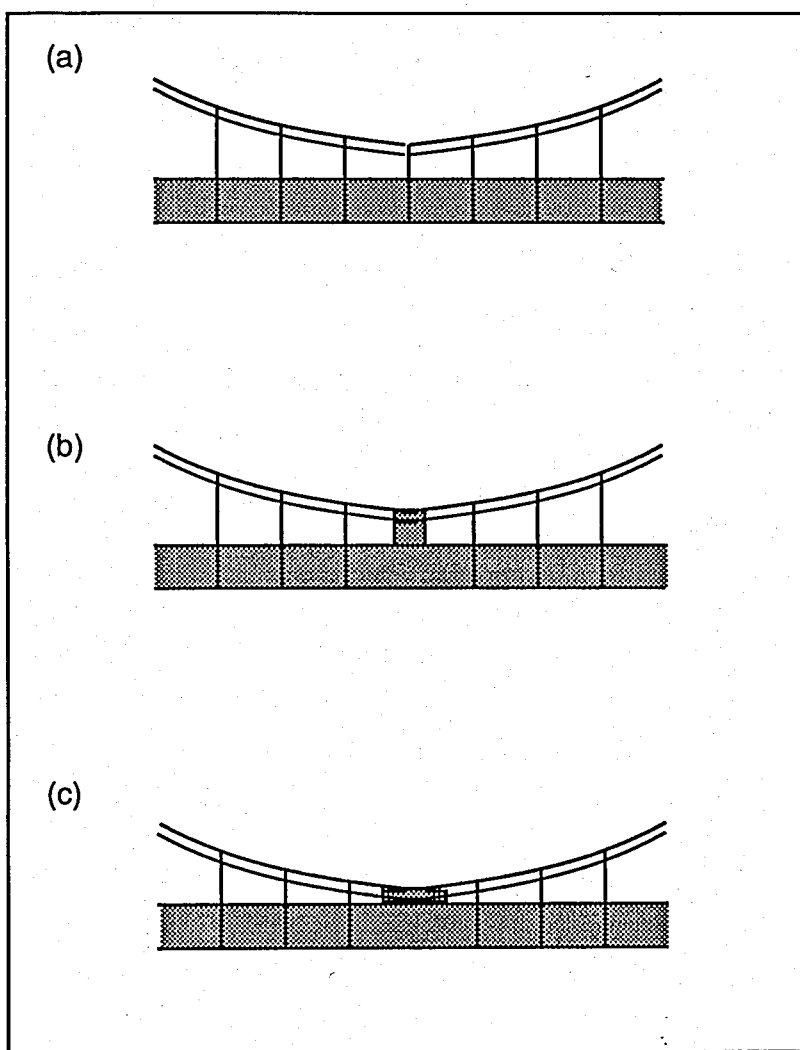

FIGURE 3.10. THREE-SPAN SUSPENSION BRIDGE WITH A CENTRAL CLAMP AND A FIXED BEARING ON ONE OF THE PYLONS



**FIGURE 3.11. CONNECTION BETWEEN THE MAIN CABLE AND THE STIFFENING GIRDER AT MIDSPAN**

By arranging inclined hangers, as indicated in *Figure 3.12*, a truss action can be created and shear forces can therefore be transferred through the cable system. As shear forces generally induce tension as well as compression in the hangers (acting as truss diagonals) the shear forces from traffic load can only reach a value determined by the condition that the compressive force from traffic load must not exceed the initial tensile force from dead load, as the resulting force in the hangers has to be tension.

The first major suspension bridge to be constructed with inclined hangers, was the Severn Bridge in the UK. Here the main reason for applying this system was to increase the damping properties of the structure. During wind excited oscillations the cable will displace longitudinally in relation to the stiffening girder and with the inclined hangers a cyclic variation of the hanger forces will result. In connection with the hysteresis found in helical cables a damping was achieved.

It has also been proposed to make the connection between the girder and the cable as a net of intersecting cables shown in *Figure 3.13*, thus further increasing the ability to transfer shear forces. With a continuous stiffening girder able to transfer normal forces at the pylon the system of *Figure 3.13* can act as a double cantilever truss.

All major suspension bridges are built with an earth anchored system where the force of the main cable is transferred to the soil through anchor blocks at the ends of the side spans. However, in some smaller suspension bridges the self-anchored system illustrated in *Figure 3.14* has been applied. At first glance it might look very promising to avoid the large horizontal forces on the anchor blocks, but taking into account that the compression in the stiffening girder requires a larger cross section leading to increased dead load and that during erection the main cable cannot be subjected to loading until the stiffening girder is in place, makes the self-anchored system less attractive. Adding to this that the self-anchored suspension system is inferior to the self-anchored cable-stayed system in almost any respect, makes it probable that a very limited number of self-anchored suspension bridges will be built in the future.

### 3.3. Construction Features

The superior economy of the suspension type for long-span bridges is due fundamentally to the following causes [3]:

- (a) Very direct stress-paths from the points of loading to the points of support;
- (b) Predominance of tensile stress;
- (c) Highly increased ultimate resistance of steel in the form of cable wire.

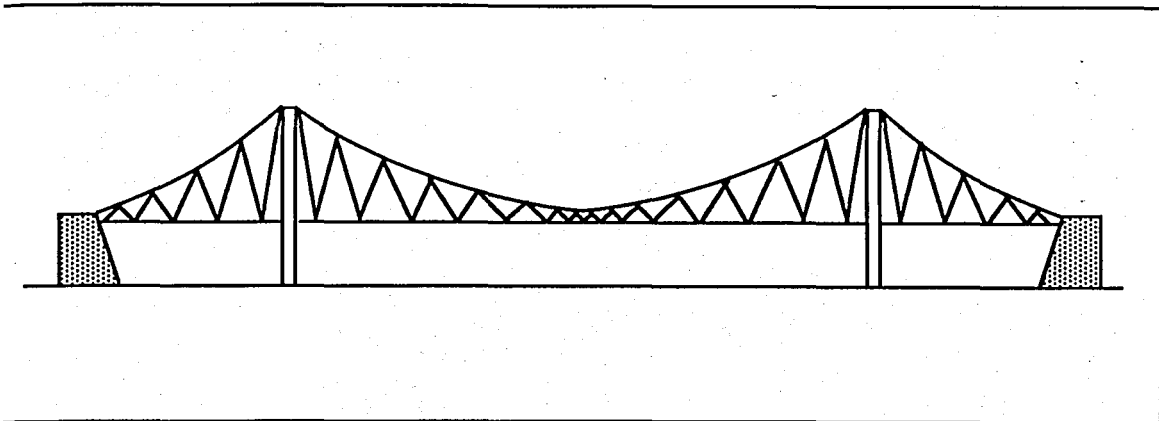

**FIGURE 3.12. SUSPENSION SYSTEM WITH INCLINED HANGERS BETWEEN THE MAIN CABLE AND THE STIFFENING TRUSS**

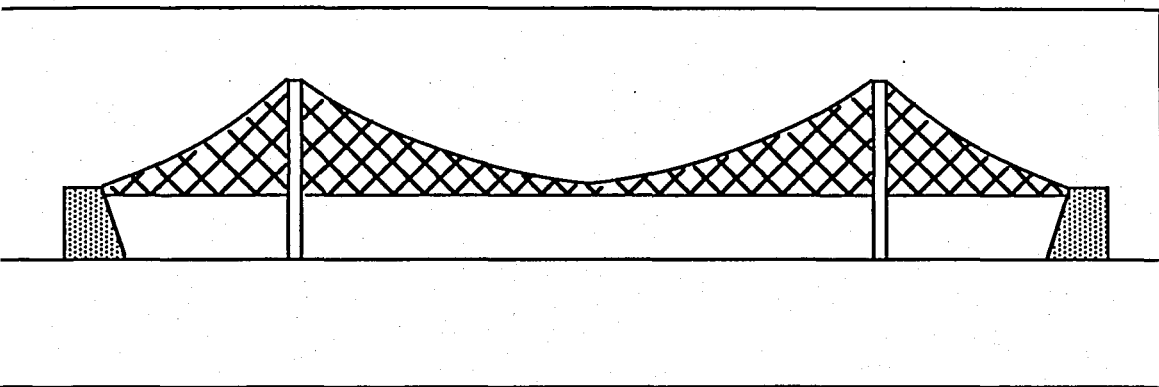

**FIGURE 3.13. SUSPENSION SYSTEM WITH A HANGER NET BETWEEN THE MAIN CABLE AND THE STIFFENING GIRDER**

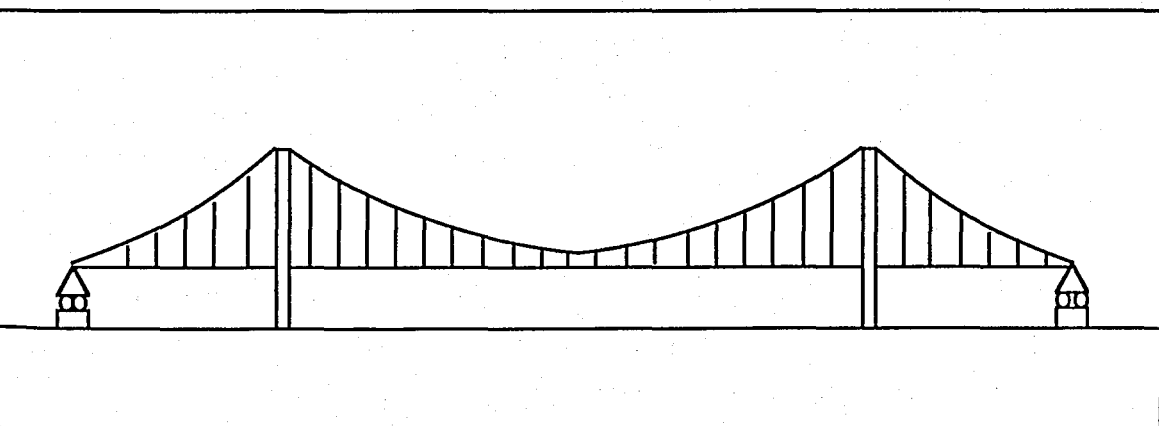

**FIGURE 3.14. SELF-ANCHORED SUSPENSION SYSTEM**

For heavy railway bridges, the suspension bridge will be more economical than any other type for spans exceeding about 500 meters. As the live load becomes lighter in proportion to the dead load, the suspension bridge becomes increasingly economical in comparison with other types. For light highway structures, the suspension type can be used with economic justification for spans as low as 120 meters.

Besides the economic considerations, the suspension bridge has many other points of superiority. It is light, esthetic, graceful; it dispenses with false work, and is easily constructed, using materials that are easily transported; there is no danger of failure during erection; and after completion, it is the safest structure known to engineers. The principal carrying member is the cable, and this has a vast reserve of strength. In other structures, the failure of a single truss member will precipitate a collapse; in a suspension bridge, the rest of the structure will be unaffected.

## 4. CABLE ANCHORAGE AND CONNECTION IN CABLE SUPPORTED BRIDGES

### 4.1. Introduction

In cable supported bridges the structural connections required in the stiffening girder and in the pylon, as well as connections between these elements and the substructure, can be designed by general principles known from other types of structures. Only when it comes to the structural connections where the elements of the cable system are attached to the stiffening girder, the pylons and the substructure have special detail to be applied. At the same time an efficient design of these details is extremely important, as the cables constitute the main load carrying elements.

### 4.2. Anchoring of the Single Strand

The anchoring of the single strands is influenced by the following features [3]:

- (a) The force in the strand is concentrated on a small cross-sectional area due to the high stresses;
- (b) Welding, bolting or riveting used to connect other parts of steel structures cannot be used to connect steel wires to other structural parts.

For *in situ* cables built up from individual wires at the site, e.g. parallel-wire cables erected by the air-spinning method, the anchoring is generally established by looping the wires around a strand shoe, as shown in *Figure 4.1*. Thus, the axial force in the wires are transferred by side pressure on the semicircular face of contact, and further from the strand shoe through threaded rods.

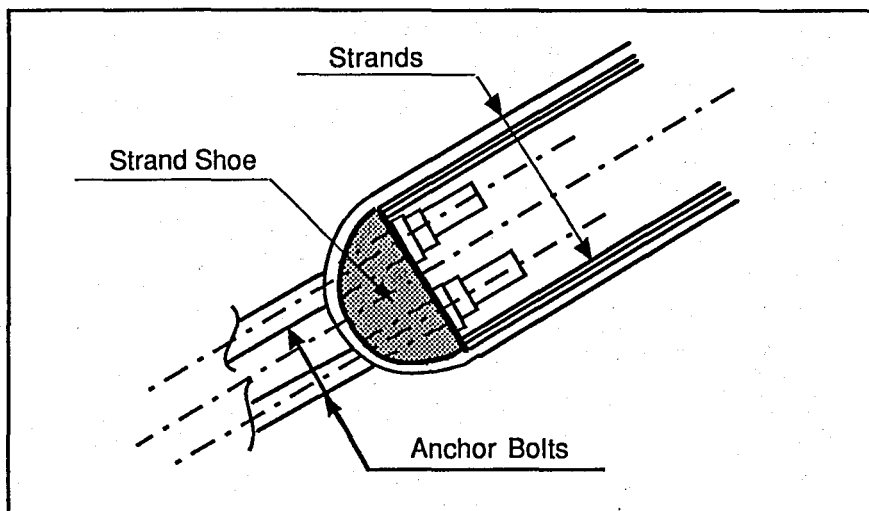

**FIGURE 4.1. STRAND SHOE FOR ANCHORING STRANDS  
ERECTED BY THE AIR SPINING METHOD**

However, in the case of eyebars used as tiers transmitting the forces from the strand shoes, these might simply consist of grooved circular discs placed in pairs on each side of the eyebars. The use of a strand shoe anchorage is restricted to cables erected *in situ*, and so this detail is found only at the anchorage of suspension bridge main cables erected by the air spinning method.

For prefabricated strands, the most common way of anchoring is by socketing the ends of the strands. In its simplest form a socket for a helical strand consists of a steel cylinder with a conical cavity in which the broomed end of the strand is inserted as shown in *Figure 4.2*. Subsequently, the conical cavity is filled with a metallic alloy having a relatively low melting temperature. When the cable is subjected to tension a wedge action will develop and a tri-axial state of stress in the material inside the cone will then efficiently promote the force transmission from the wires.

For the anchoring of parallel-wire strands a special socket, as shown in *Figure 4.3*, is found in most modern applications. Here the wires are led through holes in a locking plate at the far end of the socket and provided with button heads to increase the resistance against sliding of individual wires.

The conical cavity inside the socket might be filled with a hot casting material (as the metallic alloy described above) but to improve the fatigue resistance of the anchor it is preferable to use a cold casting material composed of epoxy resin, zinc dust, and small hardened steel balls.

*Figure 4.4* shows a typical socket based on the application of a cold casting material. To indicate the higher fatigue resistance of this socket it is called a HiAm socket, where HiAm stands for high amplitude.

Besides the bearing sockets described above other more complicated forms of sockets are also found. Such sockets are designed to give advantages in relation to tensioning, adjusting, and load transferring.

For the bearing socket, force transmission to the adjoining structure generally takes place through a bearing block to diaphragms in rigid connection with the structure, as shown in *Figure 4.5*. As the hole in the bearing block will have a diameter that is only slightly larger than the strand diameter, the bearing block must be placed on the strand before the ends are socketed. To allow the strand to be inserted between the diaphragms during erection, the bearing block must be of a rectangular shape so that it can pass when turned through 90° in relation to its final orientation.

For mono-strand cables it is important to avoid the cable bending being concentrated at the cable entrance to the socket. Thus, with a cable anchorage as shown in *Figure 4.5*

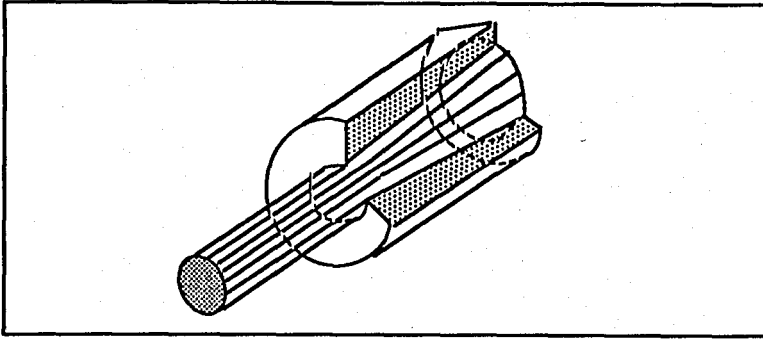

FIGURE 4.2. CABLE SOCKET

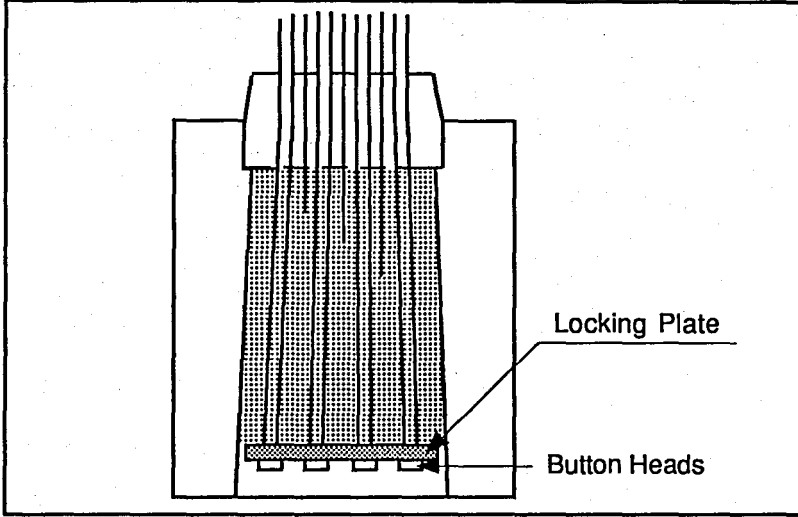

FIGURE 4.3. SOCKET FOR PARALLEL WIRE STRAND

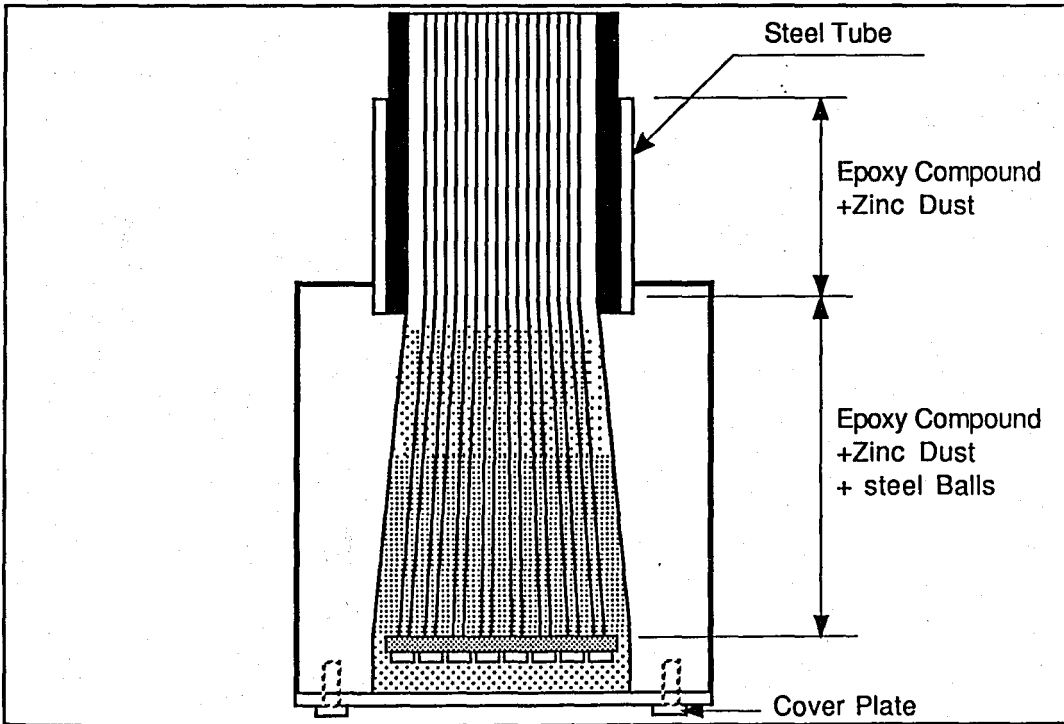
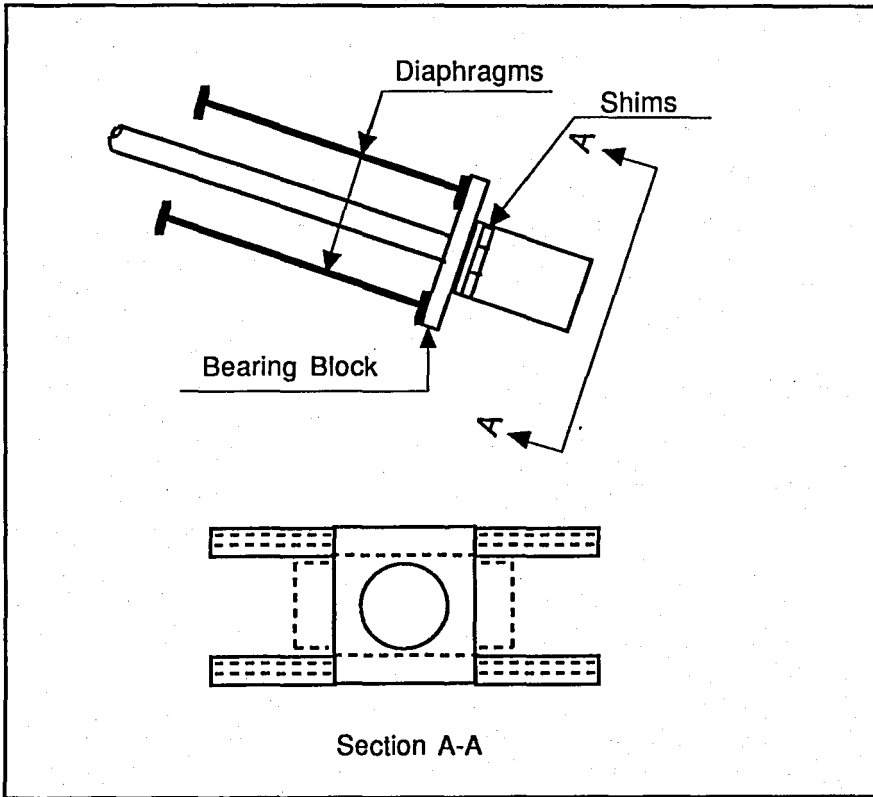

FIGURE 4.4. HIAM SOCKET



**FIGURE 4.5. RECTANGULAR BEARING BLOCK**

a lateral support of the cable should be provided some distance from the socket, as shown at the bottom of *Figure 4.6*.

### 4.3. Anchoring of Multi-Strand Cables

To anchor a multi-strand cable the individual strands are flared from a cable collar to allow a separate anchorage of each strand. A typical arrangement of a multi-strand cable anchorage as found in cable stayed bridges is shown in *Figure 4.7*. It is seen how the individual strands are leaving the collar are led to sockets supported by bearing blocks and radial diaphragms [3].

The collar is made of two cast steel parts connected by bolts. In the final structure the cable collar will often be attached only to the cable, if friction is sufficient to prevent a sliding of the collar. Otherwise a simple longitudinal tie of double-sided flat bars might be used to connect the collar to the adjoining structure. With this arrangement shown in *Figure 4.7* the angular changes due to the sag variations of the stay cable will take place at the collar. Thus, the undesirable angular changes at the sockets of individual strands are excluded. During installation of strands, the collar has to be temporarily supported laterally to allow the strands to be added layer by layer.

When placing the layers of the lower half, only the bottom of the collar has to be in place, but when the strands to be bent upwards are installed and tensioned initially, the top of the cable collar must be added. However, during this operation the bolts can be loosened sufficiently to allow a mutual sliding between the individual strand layers.

The arrangement of *Figure 4.7* with a symmetrical spreading of the strands in the vertical plane is only feasible if the number of layers is three or less. This is due to the fact that great difficulties will result during installation if more than one layer should be bent upwards.

In most cable stayed bridges with multi-strand cables the cable collar is placed at the point where the stay cable is entering the stiffening girder so that the spreading of the strands takes place inside the girder.

Generally it can be stated that the anchoring of a multi-strand cable implies several complications during erection and this is one of the more important reasons why the trend within the cable bridges is to change from systems with few multi-strand cables to multi-cable systems containing mono-strand cables only.

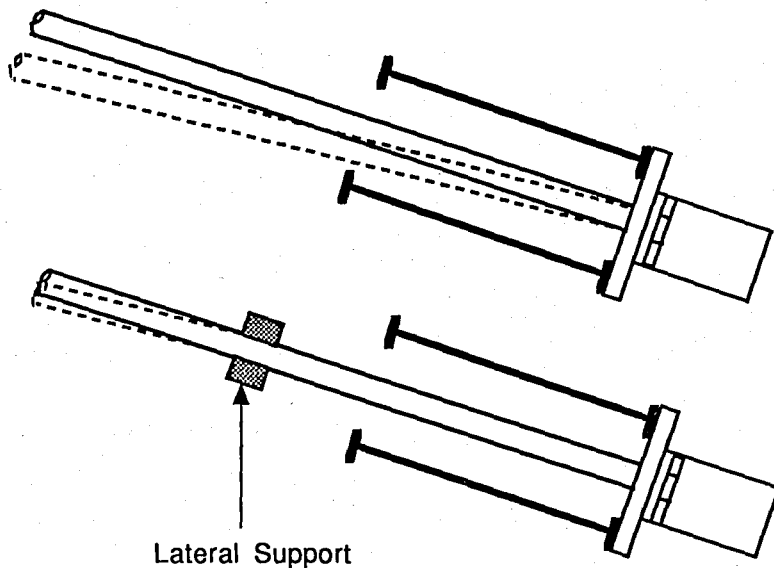

FIGURE 4.6. ELIMINATION OF ANGULAR CHANGES AT THE SOCKET

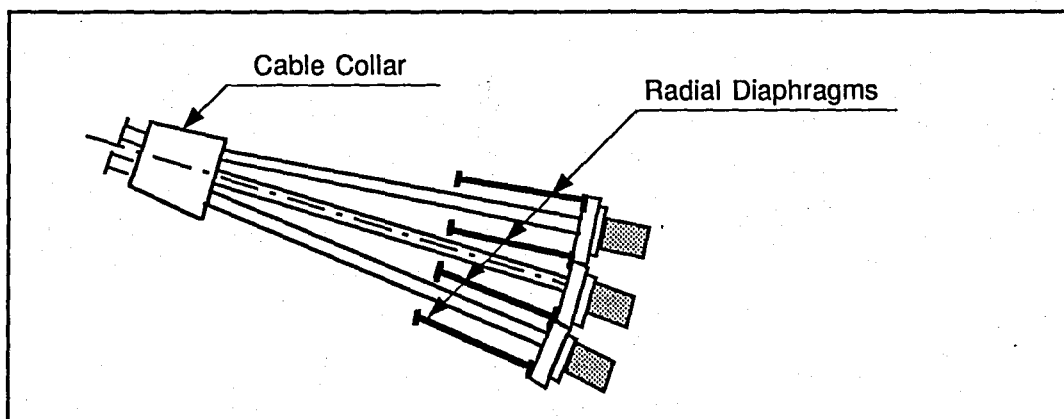

FIGURE 4.7. ANCHORAGE OF A MULTI-STRAND CABLE

The problems related to the symmetrical spreading of the multi-strand cable with more than three layers of strands can be overcome by using a one-sided flaring only, as indicated in *Figure 4.8*. Here the cable collar is substituted by a splay saddle supported to the adjoining structure in such a way that the transversal force component can be transferred. With this arrangement, generally found in the anchor blocks of suspension bridges, the total cable can be erected by adding the strands layer by layer starting from the bottom.

#### 4.4. Connection Between Cable and Stiffening Girder

When designing a cable supported bridge, it is very important to follow thoroughly the transmission of forces from the cables into the stiffening girder to ensure an efficient design of these important details [3].

In some cases the stiffening girder (truss) will have a cross-sectional layout that follows a most direct connection to the cables, as indicated in *Figure 4.9 (a)-(d)*. With these cross sections only small diaphragms or brackets are required to transfer the forces from the cables to the main elements of the stiffening girder.

In other cases the main load-carrying elements of the stiffening girder will be situated at such distances from the cable planes that larger structural elements have to be added at the cable anchor points to ensure the transmission of the cable forces. Thus, with the cross sections of *Figure 4.10 (e)-(f)*, and (g) the cables will only come into immediate contact with secondary structural elements such as the floor beams or the edge girders.

In *Figure 4.11* is shown the principle layout of the connection between a stay cable and a wide, single cell box girder. As seen, two transversal and two longitudinal bulkheads are required at the cable anchor point.

The force is initially transferred from the cable through sockets, bearing blocks, and small radial diaphragms to the longitudinal bulkheads. From these the horizontal cable force component is transferred by shear to the deck plate and the bottom flange of the stiffening girder, whereas the vertical component is transferred from the longitudinal bulkheads to the transverse bulkheads and further by shear to the girder webs.

The layout shown in *Figure 4.11* will be used in cases where the cable force to be transmitted is of considerable magnitude, i.e. in bridges with few multi-strand stay cables.

In bridges with a multi-cable system the forces to be transferred at each anchor point is of a more modest magnitude and it is therefore unnecessary to arrange full-depth

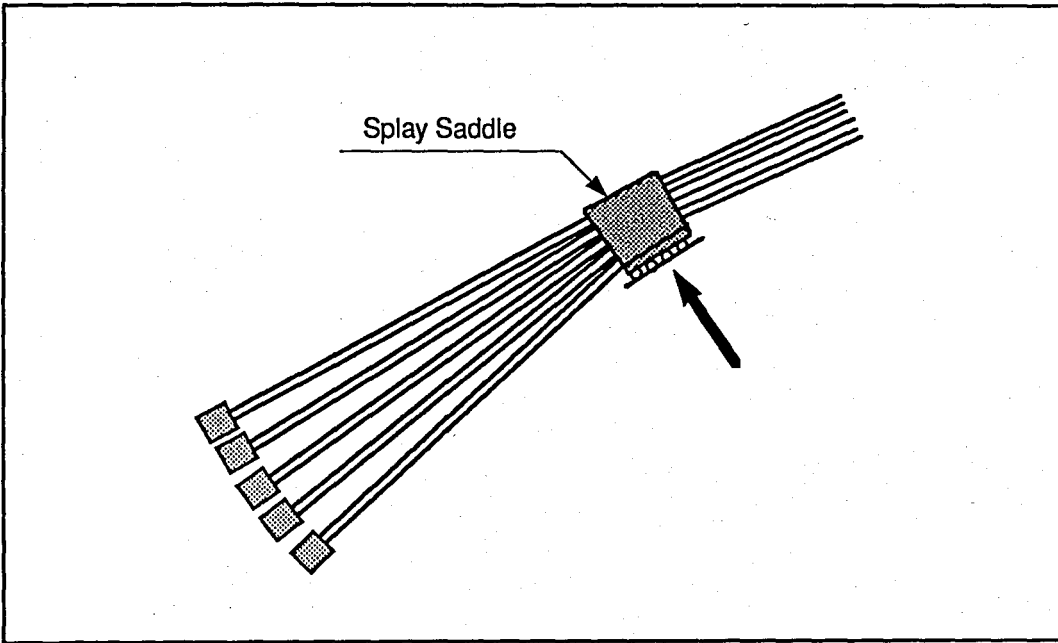

**FIGURE 4.8. ONE-SIDED FLARING OF STRANDS FROM SPLAY SADDLE**

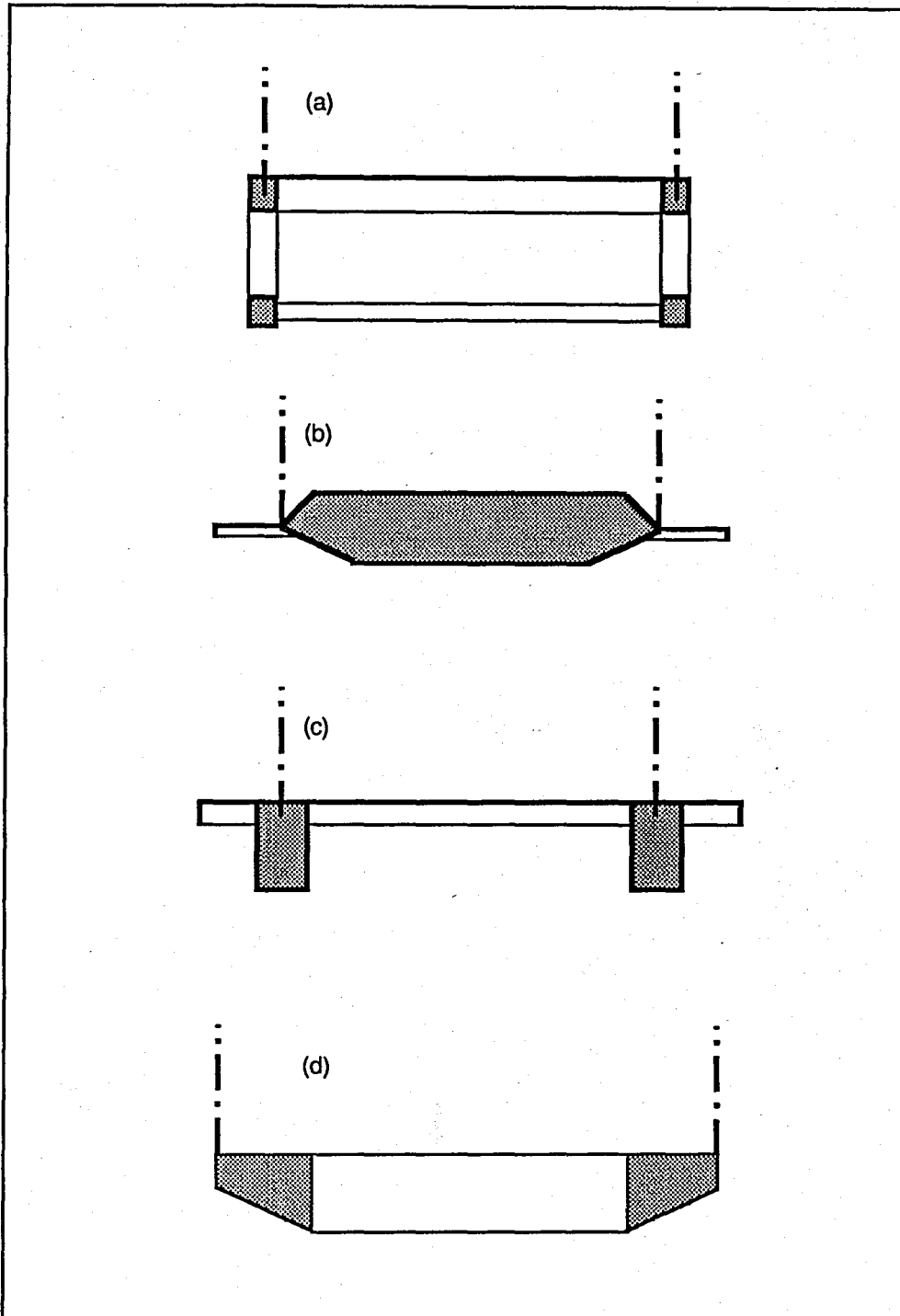

**FIGURE 4.9. TYPES OF STIFFENING GIRDER SECTIONS ALLOWING A DIRECT CONNECTION TO THE CABLES**

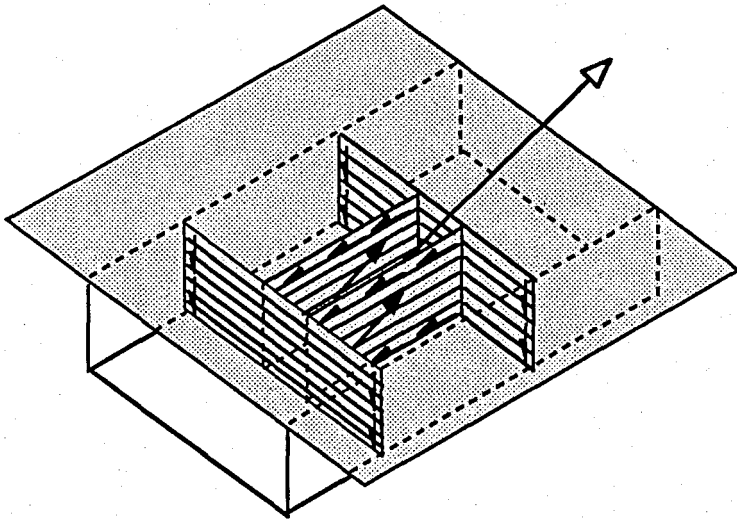

**FIGURE 4.11. CONNECTION BETWEEN A LARGE MULTI-STRAND STAY CABLE AND A WIDE MONO-CELLULAR STIFFENING GIRDER**

bulkheads at these points. Instead, a layout as shown in *Figure 4.12* can be used. Here the stay cables are anchored to a continuous, longitudinal anchor girder under the deck plate, from where the vertical force component is transferred by two inclined ties leading to the bottom of the box to the outer webs.

For a stiffening girder containing two plate girders positioned some distance from the edges, the layout of the anchor point in principle will be as shown in *Figure 4.13*. Here the stay cables, placed outside the roadway area, are anchored to an inclined anchor girder that transfers the cable forces by bending and shearing to the plate girder webs.

The application of inclined anchor girders is not restricted to bridges with two plate girders (as in *Figure 4.13*) but it can also be used in bridges with more plate girders or with box girders.

Inclined anchor girders will be used at points where large cable forces have to be transmitted, whereas a more simple layout will be used in bridges with a multi-cable system, such as the one shown in *Figure 4.14*. Here the edge girders act as continuous, longitudinal anchor girders connected by inclined ties to the box girder bottom flange at the anchor points.

The fact that the vertical force component to be transferred from each cable anchorage in a multi-cable system is of limited magnitude, also makes it possible to apply ordinary vertical transverse girders.

In cable stayed bridges the horizontal component of the cable force will be transferred to the stiffening girder inducing normal stresses. However, as the horizontal component will be generally be applied to a concentrated part of the girder, the normal stress will not be distributed uniformly near the cable anchor point.

#### **4.5. Connection Between Main Cable and Hanger**

In suspension bridges the connection between the main cable and the hangers is made by means of a cable band, clamped to the main cable and shaped to give support for the hangers [3].

The cable band consists of two semi-cylindrical halves connected by high-tensile steel bolts to develop the necessary friction. As the cable bands must conform with the cable shape after stressing, a relatively thin wall thickness and good ductility is required.

In *Figure 4.15* the situation before and after the tightening of clamping bolts is shown with some exaggeration. During tightening the cable bands will be subjected to a bending

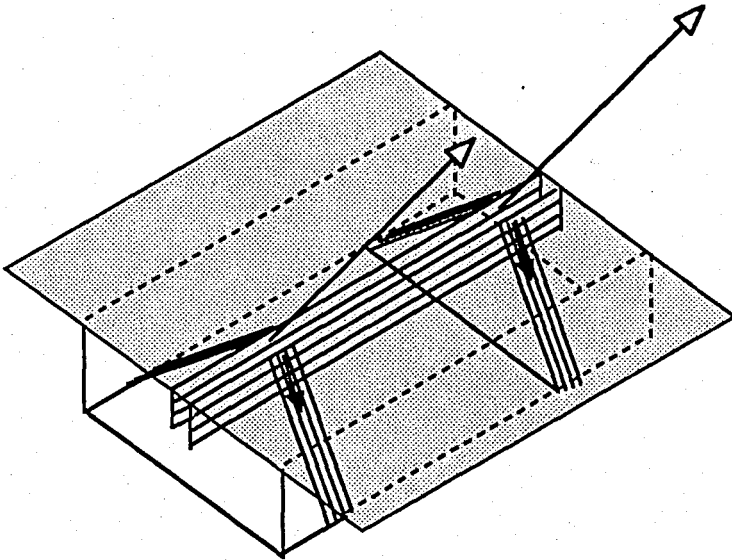

**FIGURE 4.12. CONNECTION BETWEEN MONO-STRAND STAY CABLES AND A WIDE MONO-CELLULAR STIFFENING GIRDER**

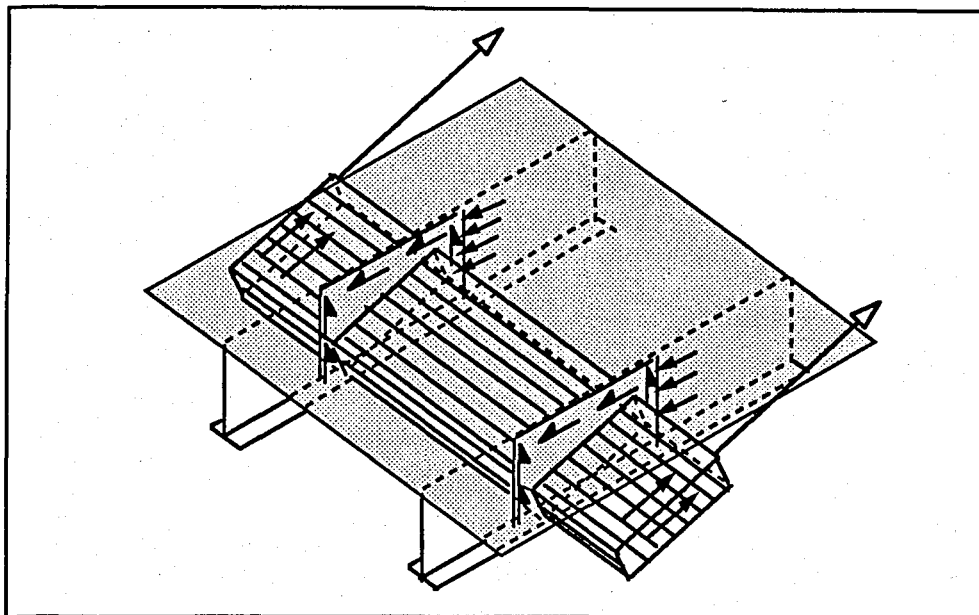

FIGURE 4.13. INCLINED ANCHOR GIRDER

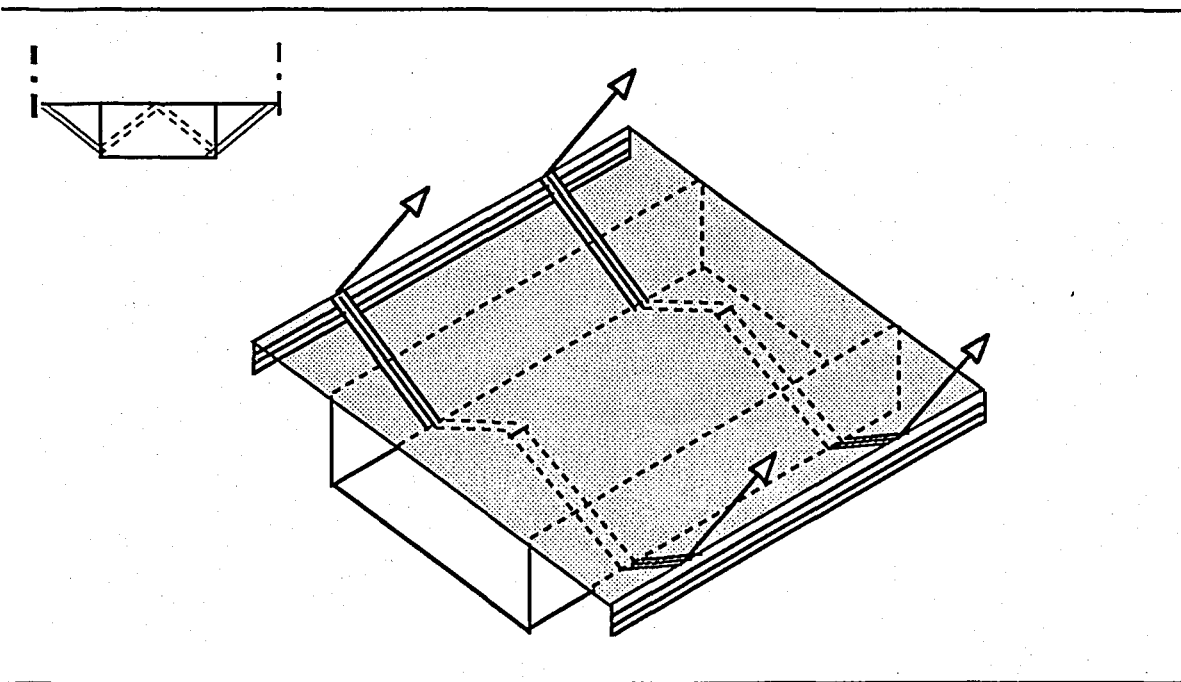

FIGURE 4.14. CONNECTION BETWEEN A CENTRAL BOX GIRDER AND MONO-STRAND STAY CABLES

that will reduce the diameter until contact is established around the cable. After tightening, a small gap must still be present between the two halves to ensure that the bolt tension is not transferred directly from one half to the other by bearing. Also, this gap should be sufficient to allow retightening of the bolts at a later date.

The bolts are generally highly stressed during tightening of the nuts, and to reduce the risk of breakage it might be advantageous to make a waisting of the bolts as shown in *Figure 4.16* so that the highest tensile stresses occur on the smooth central part of the bolt. With such a waisting, the bolts might actually be tightened into the plastic range to provide a margin against relaxation.

The required friction at the cable bands depends on the inclination of the cable, and the largest friction is consequently required near the pylons. For this reason the number of bolts in each cable band is generally increased from midspan towards the pylons. An exception to this rule might be the cable bands at the ends of a continuous stiffening girder, as these bands might be subjected to quite large forces due to a pronounced inclination of the short hangers under asymmetrical load and temperature change.

To give support for the hangers, the cable bands are often provided with grooves on the upper surface so that the hangers can simply be looped around the band, as shown in *Figure 4.17*. Here is also indicated the application of a hanger clamp below the cable band to reduce the distance between the hanger ropes. Whether such a hanger clamp has to be used depends on the requirements of hanger rope spacing at the stiffening girder.

Hanger clamps to reduce the hanger rope spacing have been used in many large suspension bridges. However, these clamps should be avoided if possible, due to the fact that they introduce a point with reduced resistance against corrosion.

As the inclination of the main cables varies along the span, and as the grooves have to be arranged in a vertical plane, a large number of molds with few re-uses have to be applied. This leads to a rather high cost of fabricating this type of cable band. On the other hand savings are achieved as no special fittings are required at the top of the hanger ropes themselves. Grooved cable bands have been used in the majority of suspension bridges built in this century.

Instead of looping the hanger cables around the band, the hanger might also be socketed at the upper end pin connected to the cable band, as shown in *Figure 4.18*. In this case the lower part of each cable band half will be shaped as a vertical gusset plate with the relevant pin holes.

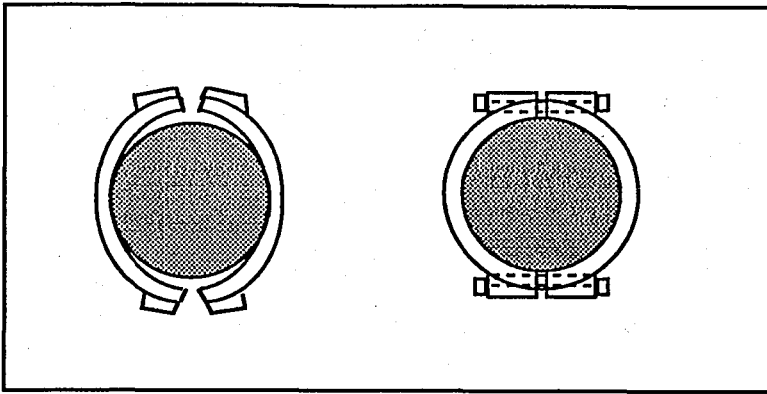

FIGURE 4.15. CABLE BAND

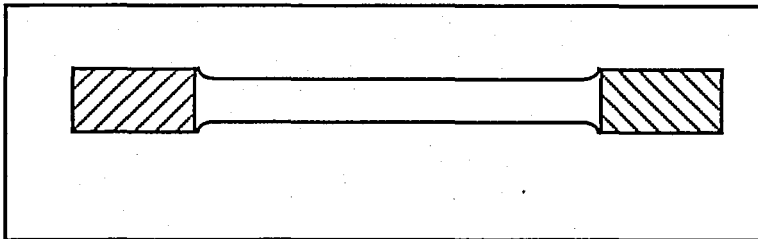

FIGURE 4.16. WAISTED BOLT

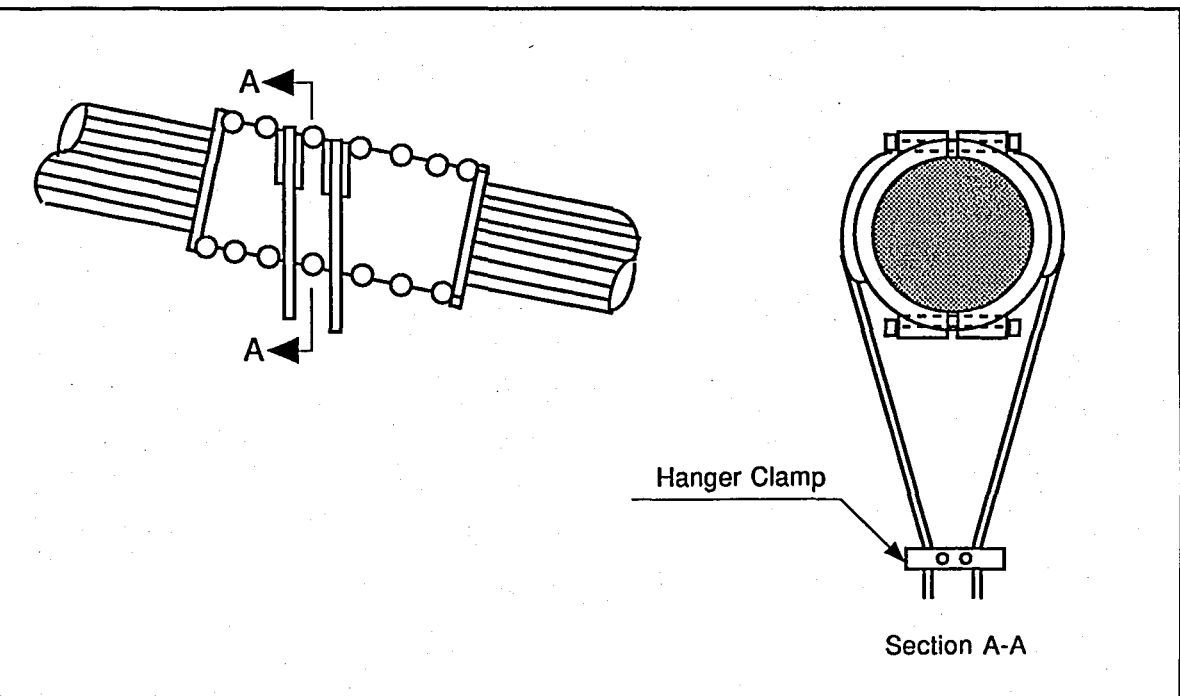
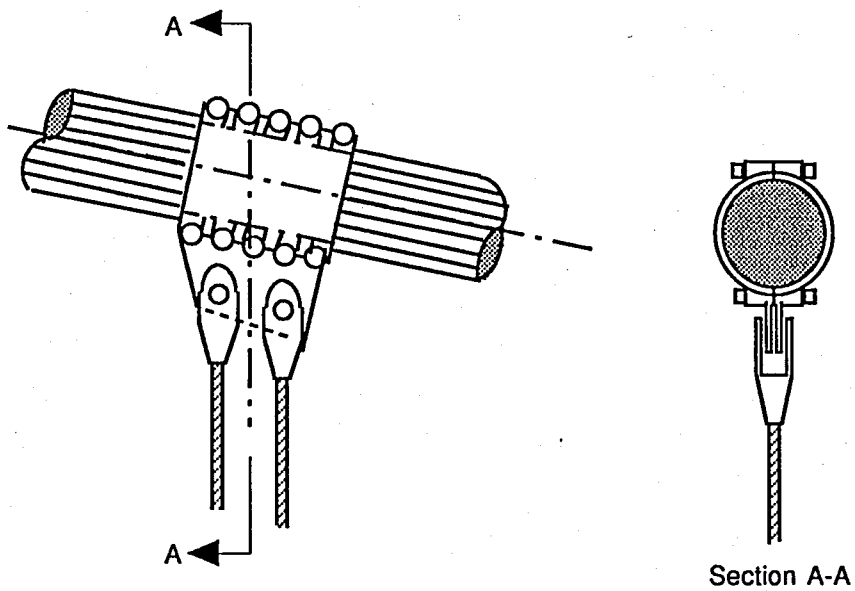

FIGURE 4.17. GROOVED CABLE BAND



**FIGURE 4.18. HANGERS CONNECTED TO CABLE BAND VIA OPEN SOCKETS**

With this arrangement a large number of cable bands can be made identical as eccentricities can be avoided by drilling the pin holes after casting of the lower part of the cable band. However, because the number of clamping bolts has to be increased with the slope of the main cable, a number of different cable band sizes will still be required.

Cable bands with socketed hanger ropes have been used in the recent bridges with inclined hangers. In bridges with inclined hangers the solution with sockets connected to a lower gusset plate is generally preferred as it reduces (or eliminates) the eccentricities that would exist with a grooved cable band, as illustrated in *Figure 4.19*.

#### 4.6. Connection Between Cable and Pylon

The connection between cables and pylon can be made either through saddles or by anchoring the cables to the pylon. In *Figure 4.20* three possibilities for the connection between a cable set and the pylon are shown [3].

In solution (a) the cable is led continuously over a saddle is fixed to the pylon. This is the type of connection preferred in suspension bridges, and the solution is also found for the connection between multi-strand stay cables and the pylon.

In solution (b) a saddle is also used, but here a longitudinal movement is made possible by applying rollers under the saddle. This principle is often found in suspension bridges during erection when mutual adjustments are required to avoid an undesirable bending of the pylon legs. However, when the erection is completed the saddle will generally be fixed longitudinally to the pylon, and the final connection will consequently correspond to solution (a).

Solution (b) has also been applied in some early cable stayed bridges to reduce the bending of the pylons, but as the total structural efficiency at the same time is reduced., it is doubtful whether overall savings are achieved.

In solution (c) the cable is discontinued at the pylon and both ends of the cable set are anchored. This principle is preferred in modern multi-cable stayed bridges as it implies a large degree of freedom in varying the number and size of the stay cables as well as their inclination. Also during transportation and erection advantages can be gained when each prefabricated cable can be made with a length corresponding to the distance from the pylon anchor point to the girder anchor point.

Solution (c) can only be used to anchor mono-strand cables, as the pylon dimensions will not allow the necessary flaring of a multi-strand cable.

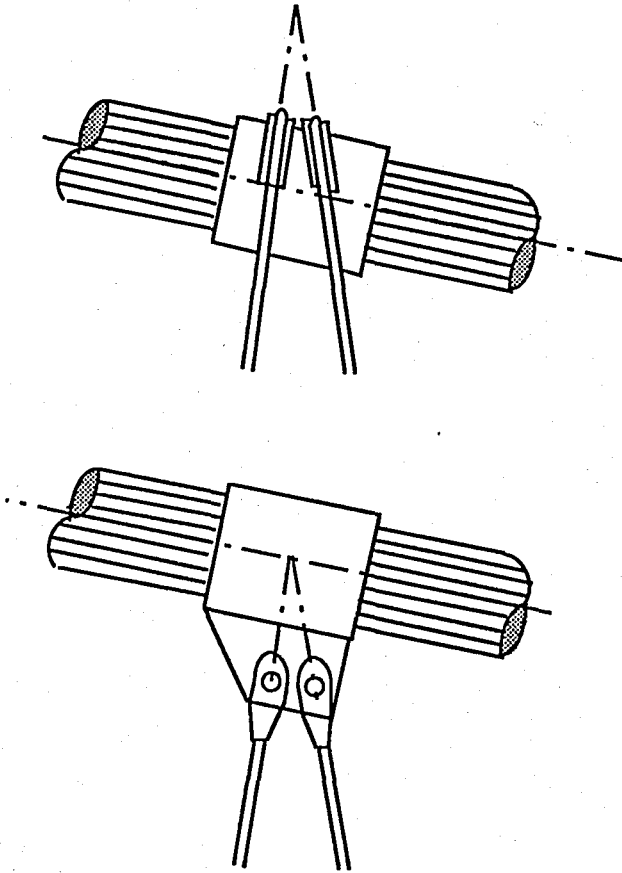

**FIGURE 4.19. CABLE BAND FOR INCLINED HANGERS**

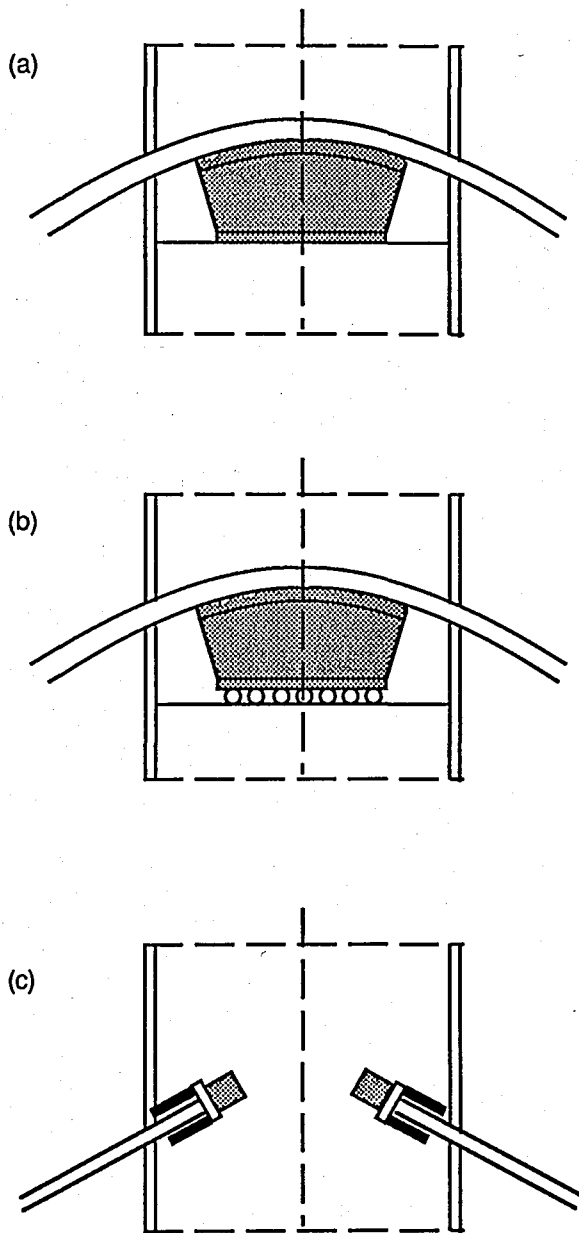

FIGURE 4.20. THREE TYPES OF CONNECTION BETWEEN CABLES AND PYLONS

Due to a large number of stay cables in a multi-cable system, it is required to have the cable anchoring zone extended over a certain height of the pylon. Thus, the typical cable system will be the modified fan with the cable anchors arranged as indicated in *Figure 4.21*. Here the sockets are placed at minimum distances to allow installation and maintenance, so that the system is as close to the pure fan as possible, when requiring the anchors to be positioned in a vertical plane.

The solution, shown in *Figure 4.21*, for anchoring of a multi-cable system to the pylon is only applicable if the pylon is made of steel, since the horizontal cable force components have to be transferred as tension through the longitudinal plates of the pylon.

For a concrete pylon the anchoring of a multi-cable system might be accomplished as shown in *Figure 4.22*. Solution (a) corresponds in its general arrangement to the solution of *Figure 4.21*, as the stay cables are anchored inside the hollow pylon on either side of the axis. As described above, this requires that the horizontal cable force components be transferred longitudinally from the left to the right face of the pylon. Thus, an efficient horizontal prestressing of the pylon will be required in the anchor zone.

In solution (b) the stay cables are led continuously through the pylon in curved tubes. By this arrangement the horizontal cable force components are directly transferred without affecting the pylon, but the solution is only applicable in connection with special erection procedures for the stay cables. Thus, the system has been used in cases where the stay cables are made of seven-wire strands being pulled individually through pre-erected tubes of stainless steel or polyethylene from one girder anchorage to the other.

With prefabricated stay cables comprising the full cross section and having socketed ends the solution of *Figure 4.22* (b) is not directly applicable, but it might still be used if couplings (as indicated with dotted lines) are arranged immediately outside the pylon. In this case the prefabricated stay cables will be straight so that no special problems arise. The couplings might be established by using threaded sockets connected by exterior sleeves or interior rods.

Finally, the anchoring of a multi-cable system could be accomplished as shown in *Figure 4.22* (c). Here the stay cables are led through the pylon and anchored on the opposite side so that an overlapping is established. By this is obtained that the horizontal cable force components induce compression in the pylon and that the sockets can be made as common bearing sockets.

Due to the required intersection of the stay cables inside the pylon and eccentricity is unavoidable if each stay cable consists of a single strand, as illustrated in *Figure 4.23* (d).

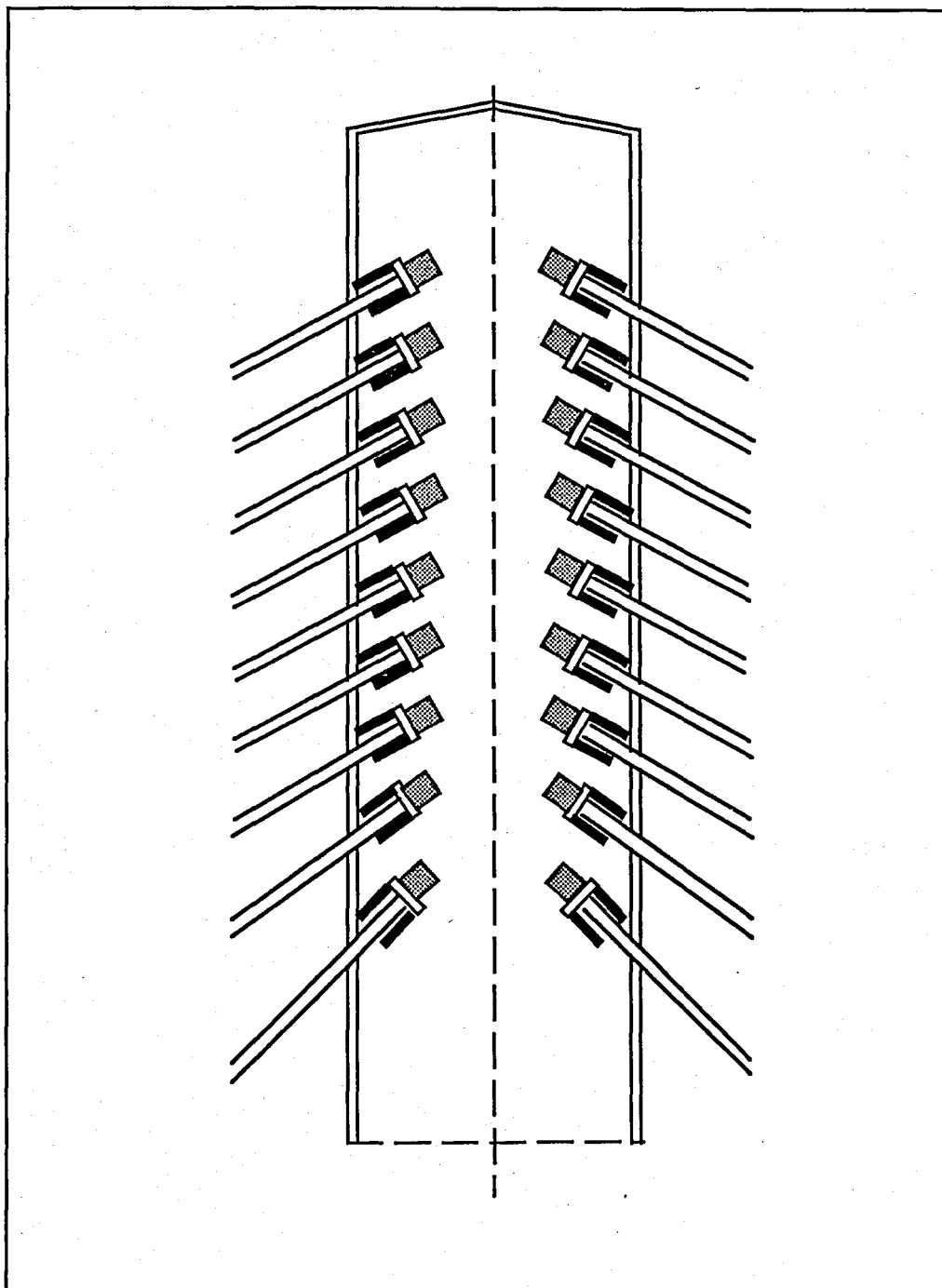

**FIGURE 4.21. ARRANGEMENT OF CABLE ANCHORS IN A MODIFIED MULTI-CABLE FAN SYSTEM**

The eccentricities will induce torsion of the pylon leg which is less attractive due to the limited shear resistance of concrete.

The eccentricity can be completely avoided if each stay cable is made of two strands arranged as shown in *Figure 4.23 (e)*. As seen the two strands are placed one on top of the other in the left span and side by side (horizontally) in the right span.

In bridges with multi-strand cables, a cable saddle will generally be used to establish the connection between the cables and the pylon.

The connection between the cable saddle and the side plates of the pylon might be established by supporting the saddle on a short longitudinal girder inside the pylon as shown in *Figure 4.24*. With this arrangement the vertical component of the cable forces is transferred only to the transverse side plates and a local reinforcing of these plates might therefore be required.

In *Figure 4.24* a possible extension of the longitudinal girder outside the pylon is indicated with a dotted line. Such an extension might be used temporarily during erection to allow a jacking of the cable saddle for the purpose of tensioning the total stay cable. This requires a vertical slot in the transverse side plates with a height chosen to allow the necessary displacement of the saddle. However, after completion of the jacking operation the slot below the girder can be closed by a filled-in-plate. At the same time the protruding parts of the longitudinal girder might be removed by flame cutting. If the cable tensioning is made without requiring the saddle to be displaced, the saddle might be integrated in the relevant erection unit for the pylon.

In cable stayed bridges with multi-strand cables a different number of strands might be required on either side of the saddle to give an adequate cross section of each stay cable. In this case some of the strands might be anchored to the pylon through sockets and diaphragm, as illustrated in *Figure 4.25*.

The cable saddles found in suspension bridges were for many years made of steel castings, but in recent construction the major part of the saddle is assembled from plates welded together. *Figure 4.26* shows a typical suspension bridge saddle with a cast steel saddle groove, connected to the base plate by a grid of longitudinal and radial plates welded together. After casting, the cable groove is machined on a rotary planning machine to suit the strand arrangement of the main cable. Furthermore, vertical spacers are placed between the strands (if the vertical hexagonal arrangement of strands is used). The radius of the saddle groove is typically chosen to be 12 times the main cable diameter. In the completed structure the cable saddle will always be fixed to the pylon, but during

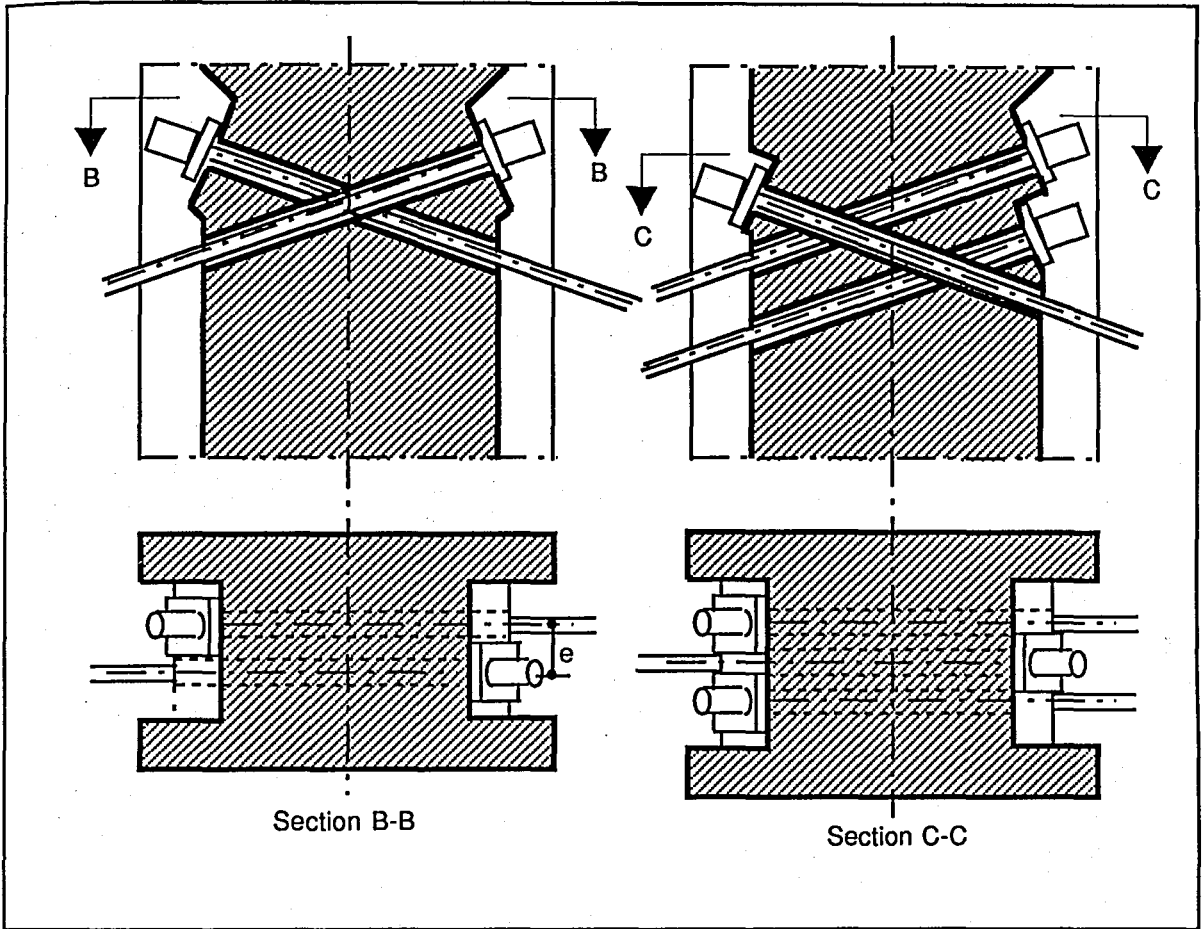

FIGURE 4.23. OVERLAPING OF STAY CABLE ANCHORAGES IN A CONCRETE PYLON

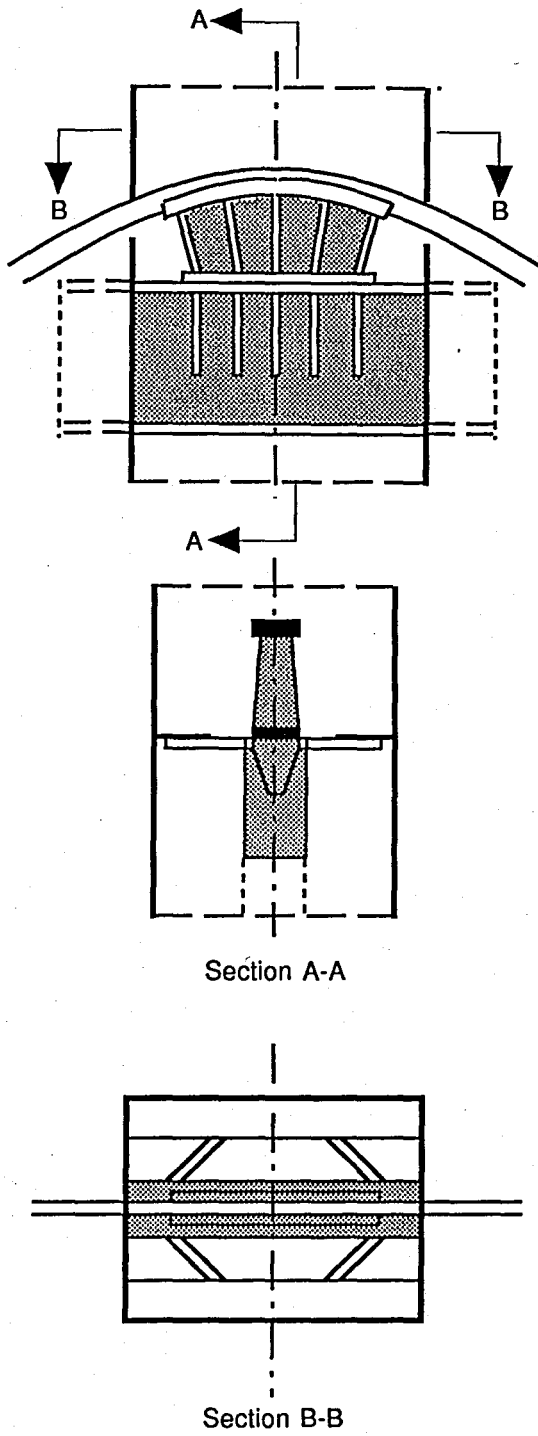

FIGURE 4.24. SADDLE SUPPORTED BY LONGITUDINAL GIRDER INSIDE THE PYLON

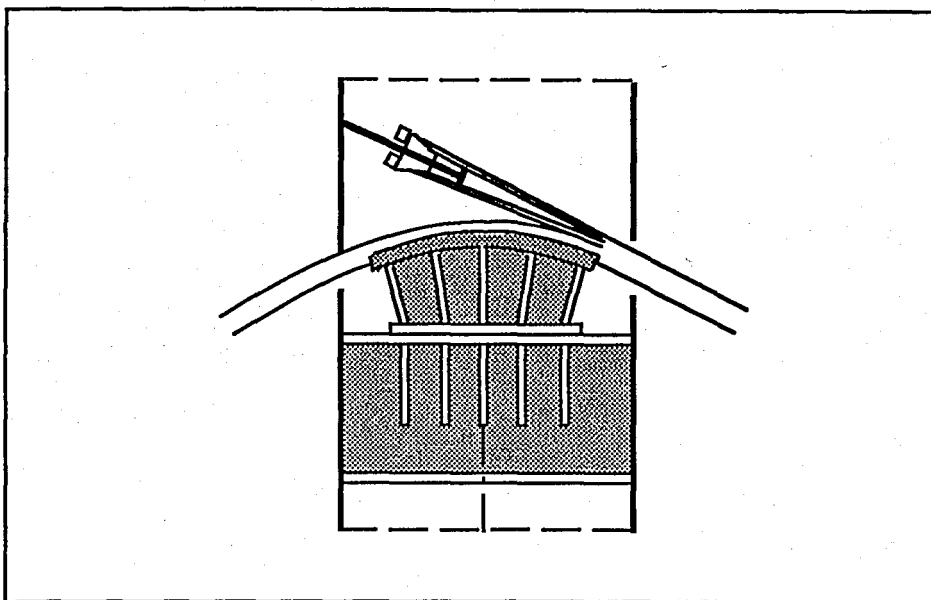

FIGURE 4.25. ADDITIONAL STRANDS

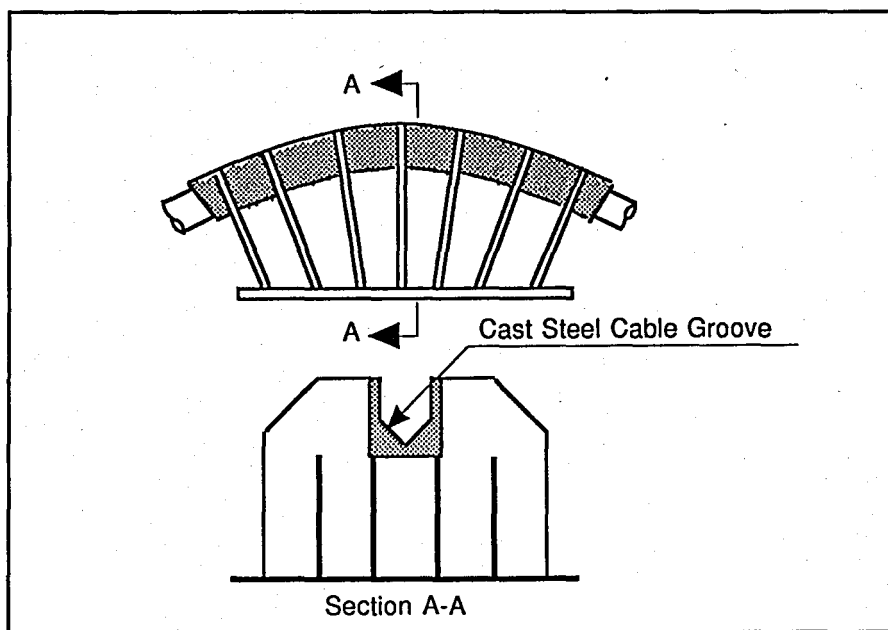

FIGURE 4.26. CABLE SADDLE

construction a longitudinal displacement between the saddle and the pylon top might be required. This is especially true in bridges with pylons having a large flexural stiffness.

In suspension bridges with relatively small side spans, the maximum cable force in the main span and the side span will differ to such an extent that it will prove advantageous to increase the number of strands in the side span cable. In this case the additional strands in the side spans are positioned on top of the continuous main span strands, and the connection to the saddle is made by strand shoes or sockets, as indicated in *Figure 4.27*.

#### 4.7. Connection Between Cable and Anchor Block

In bridges with earth anchored cable systems the total force of the main cable has to be transferred through the anchor block is established by anchoring the individual strands to the concrete of the block. Thus, the cable is separated into strands by passing a splay saddle, as was illustrated in *Figure 4.8*.

Flaring of the strands takes place inside a splay chamber in the anchor block, and at the far end of this chamber the strands are anchored by strand shoes or sockets. From the strand shoes or sockets the strand force are transferred to the block by steel bars embedded in the concrete [3].

In *Figure 4.28* is shown a number of solutions applied to lead the strand forces into the concrete of the anchor block. Under (a) is shown the traditional solution used in major American suspension bridges built in the first half of this century. Here the strand forces are transferred from the strand shoe through a chain of eyebars to an anchor girder at the back of the anchor block. The length of each eyebar, and thus the number of tiers in the chain, is determined by the size of the steel plates from which the eyebars are cut or by restrictions due to transportation and erection.

In connection with the application of eyebars for transmission of the strand forces, strand shoes will generally be used. As these strand shoes do not allow any length adjustments some of the eyebars are provided with elongated holes to permit shimming.

Instead of eyebars the strand forces might also be transferred through rods threaded at the upper end. With this arrangement, indicated in *Figure 4.28* (b), the length adjustment takes place between the strand shoe and the threaded rods. The limiting factor for the application of solution (b) is the length of the rods, as long and heavy rods are difficult to handle during construction.

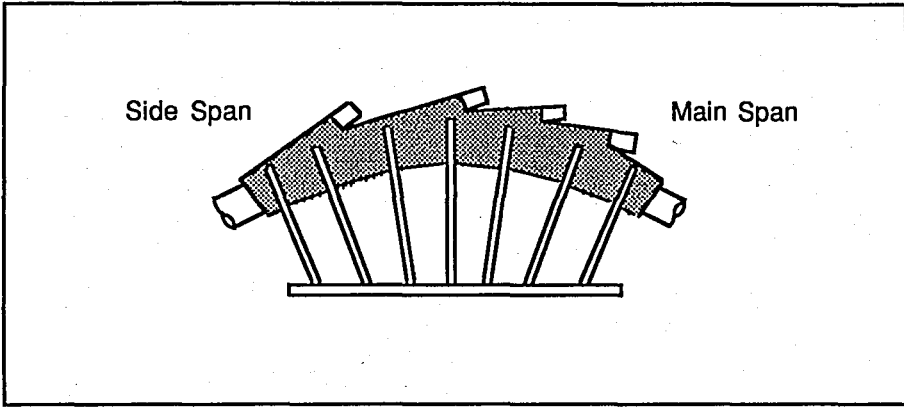

**FIGURE 4.27. SUSPENSION BRIDGE CABLE SADDLE**

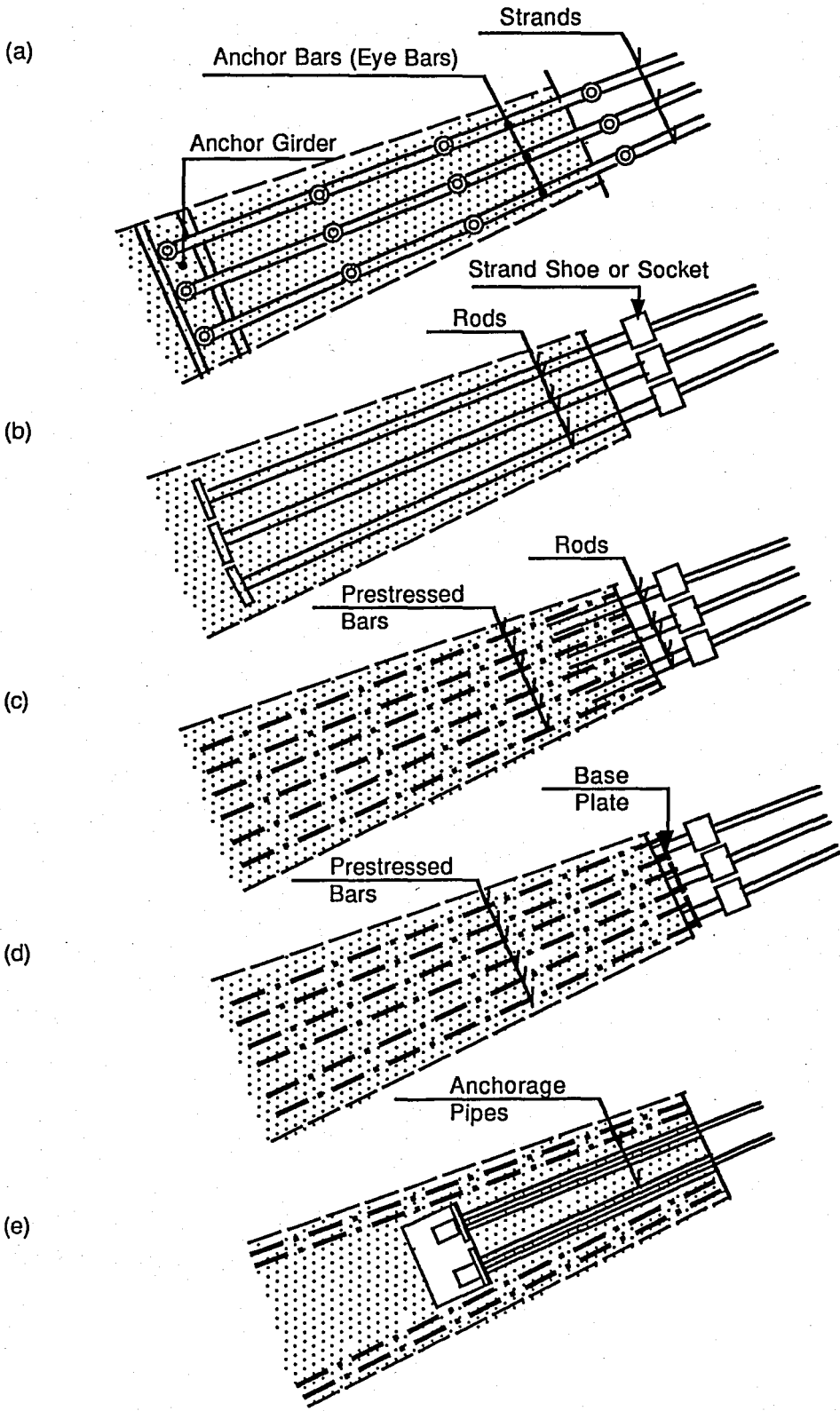

FIGURE 4.28. FIVE SOLUTIONS FOR THE TRANSMISSION OF STRAND FORCES.

After introduction of the prestressing technique in reinforced concrete construction it has proved advantageous to use posttensioned bars or cables to transmit the strand forces to the concrete of the anchor block. Thus *Figure 4.28 (c)* shows a solution with the strand shoes or sockets connected to relatively short rods embedded in the concrete over a length just sufficient to assure force transmission by bond. Further transmission of the forces into the concrete is then established by prestressed bars.

Alternatively, the transmission of the strand force to the prestressed bars could take place at the outer face of the concrete by connecting the threaded rods through base plates to the prestressed bars as indicated in *Figure 4.28 (d)*.

In bridges with main cables erected by the parallel wire strand method the solution of *Figure 4.28 (e)* has been applied. Here the strands are provided with conventional bearing sockets that are pulled through anchorage pipes and anchored inside the concrete. Again in this case further transmission of the cable force is established by prestressed bars.

After having transferred the cable force to the anchor block as described above the further transmission to the soil is much influenced by the local conditions.

The most common type of anchor block is probably the gravity type shown in *Figure 4.29*. With this type of anchor block a very large dead load is required to counteract the vertical component of the cable force and give sufficient pressure at the foundation level to assure the transmission of the horizontal cable force component.

In major suspension bridges the gravity type anchor block will be characterized by very large dimensions, and efforts are consequently made to improve their appearance by architectural treatment. In cases where sound rock is present at the location of the anchorage it will be often advantageous to embed the anchorages in the rock rather than to use gravity anchorages at about ground level.

As illustrated in *Figure 4.30*, showing one of the anchorages of the Firth of Forth Bridge, the anchorage is made as a concrete block filling a tapered tunnel driven into the rock. In this system, the strand forces are transmitted to the concrete block by a longitudinal prestressing according to the system of *Figure 4.28 (d)*.

The main dimensions of the concrete block depend on the size of the cable force  $s$ , the shear strength of the rock, the friction between the concrete and the rock, and the quantity of overburden above the rock.

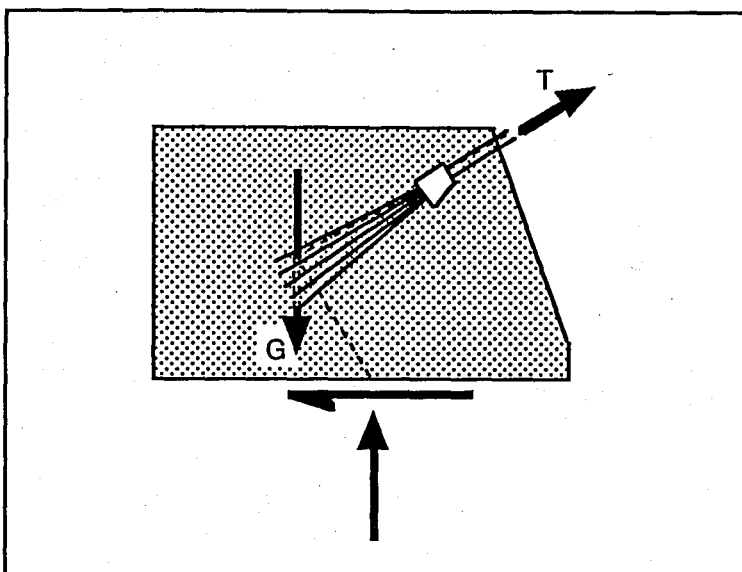

FIGURE 4.29. GRAVITY TYPE ANCHOR BLOCK

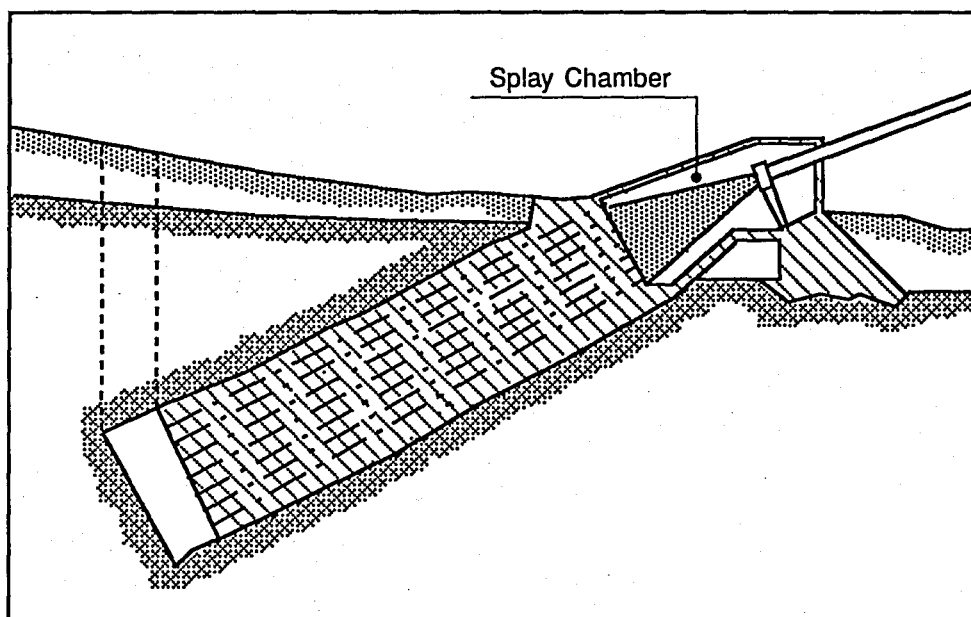

FIGURE 4.30. MAIN CABLE ANCHORAGE IN ROCK (*Firth of Forth Bridge in Scotland*)

## 5. ERECTION OF CABLE-SUPPORTED BRIDGES

### 5.1. Introduction

For the concept and design of cable supported bridges, aspect related to erection have a very strong influence, as is the case for any structure of considerable size. Thus, the structural system and material as well as the design of details must be chosen with due regard to the erection procedure.

### 5.2. Erection of Bridges with Earth Anchored Cable Systems

The erection procedure to be used depends strongly on the anchoring of the cable system as this will determine the sequence of erecting the cable system and the stiffening girder. With a fully earth anchored cable system, as found in all major suspension bridges, the cable system can be completed first and subsequently used to erect the stiffening girder. This feature is illustrated by the erection procedure outlined in *Figure 5.1*. Here six stages of a typical suspension bridge erection are indicated [3]:

*Stage 1.* Construction of the main piers, pylons and anchor blocks.

*Stage 2.* Erection of the main cables.

*Stage 3.* Start of erection of the stiffening girder from the center of the main span. When the weight of the stiffening girder is added stepwise to the main cable large displacements and changes of curvature occur, and the joints between the sections of the stiffening girder are therefore initially left open to avoid excessive bending of the girder sections.

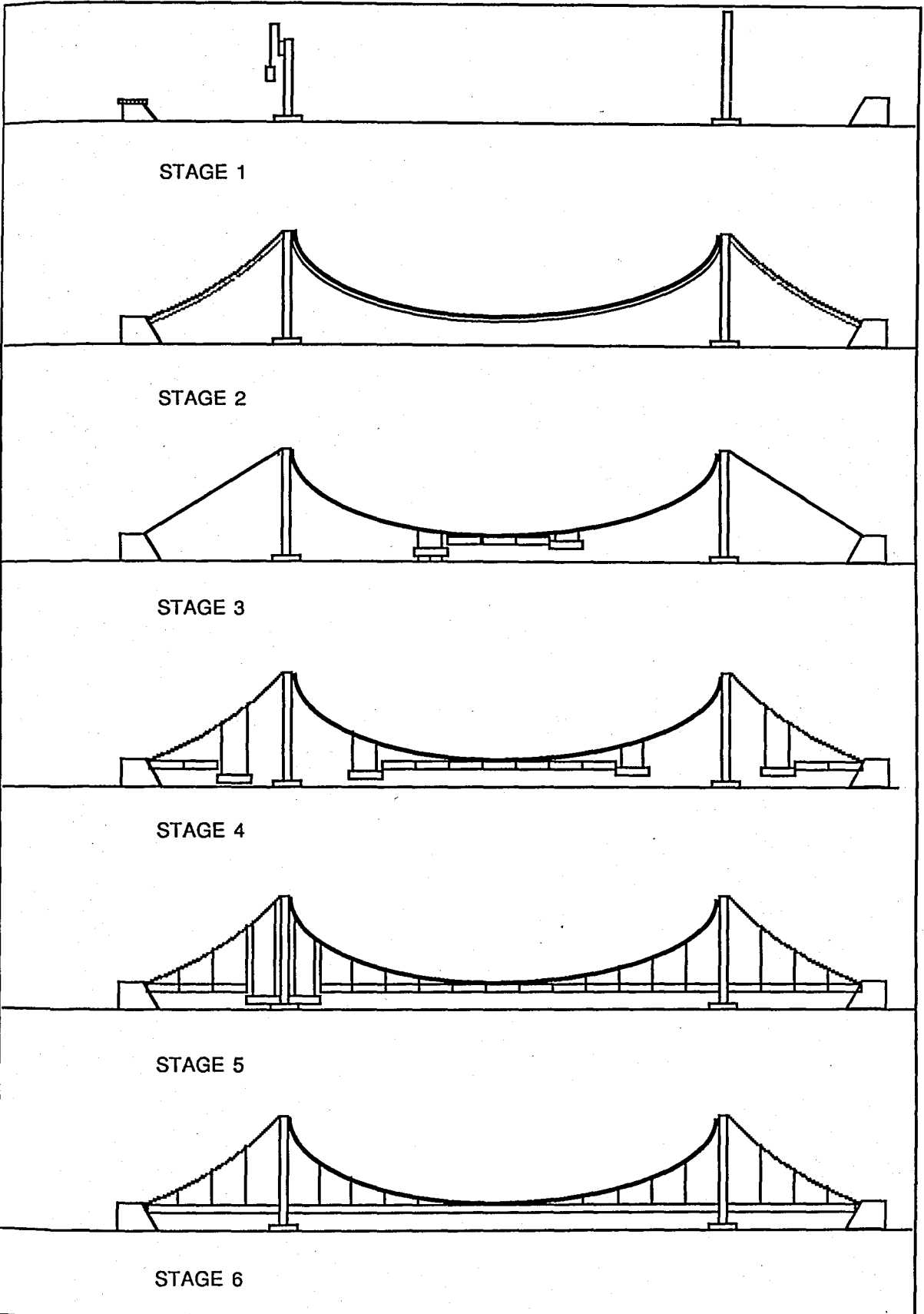

FIGURE 5.1. ERECTION FROM MIDSPAN TOWARDS THE PYLONS

*Stage 4.* Erection of the stiffening girder in the side spans to reduce the horizontal displacements of the pylon tops.

*Stage 5.* Erection of the closing pieces in the stiffening girder at the pylons.

*Stage 6.* Closing of all joints in the stiffening girder. Actually, the closing of these joints will often start already during stages 4 and 5, as soon as adjoining sections reach their correct position.

The erection procedure outlined has the advantage that the girder sections adjacent to the pylons are placed when the main cable is reaching its final configuration. This makes it possible to reduce the secondary stress in the main cable, as the final tightening of the cable bands near the pylons can be postponed to a stage when only insignificant permanent angular changes of the main cable at the pylon top remain.

Another erection procedure to be found within suspension bridges is illustrated in *Figure 5.2*. As seen, here the sequence of erecting the elements of the stiffening girder is exactly opposite to that of the erection procedure shown in *Figure 5.1*.

The erection procedure of *Figure 5.2* is advantageous in relation to the planning of the work as the erection crew can easily be transported to the bridge deck from the main piers, and also easily be moved from the main span to the side span. With the procedure of *Figure 5.1*, the erection crew has to use the cat-walk to get to the partially erected stiffening girder in the main span (during stages 3 and 4).

### **5.3. Erection of Bridges with Self-Anchored Cable Systems**

In bridges with self-anchored cable systems, the load carrying capacity of the single cable is completely dependent on the transfer of the horizontal component of the cable force through the stiffening girder. Thus, a given cable cannot be installed before the adjoining part of the stiffening girder has been erected [3].

A straightforward solution is to erect the entire stiffening girder on temporary supports before adding the cables, as illustrated in *Figure 5.3* for a cable stayed bridge with a self-anchored fan system. In the four stages indicated, the following main operations are performed :

*Stage 1.* Erection of the stiffening girder on the permanent piers and the temporary supports. In this stage the erection is actually a normal girder erection and any of the procedures used for the construction of girder bridges can consequently be applied.

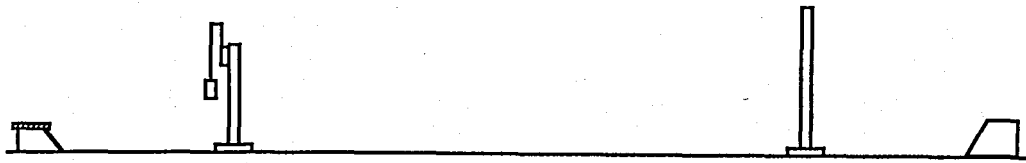

STAGE 1

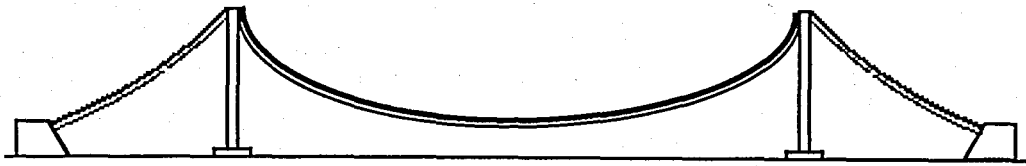

STAGE 2

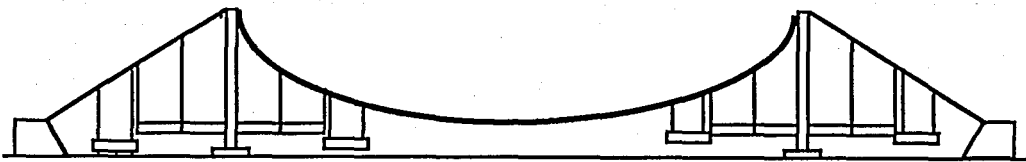

STAGE 3

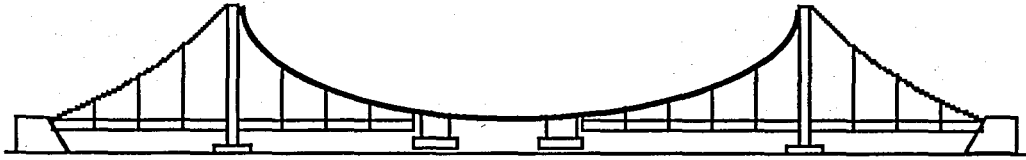

STAGE 4

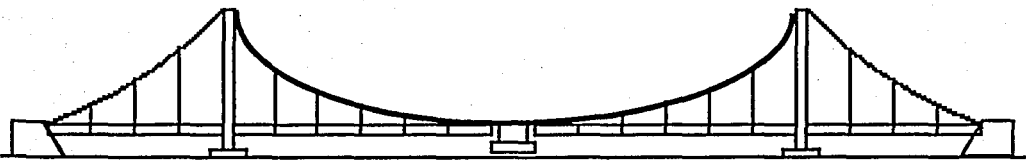

STAGE 5

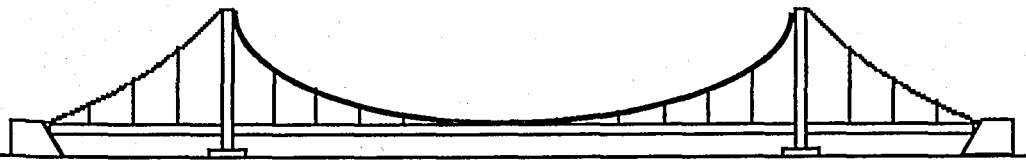

STAGE 6

**FIGURE 5.2. ERECTION FROM THE PYLONS TOWARDS MIDSPAN**

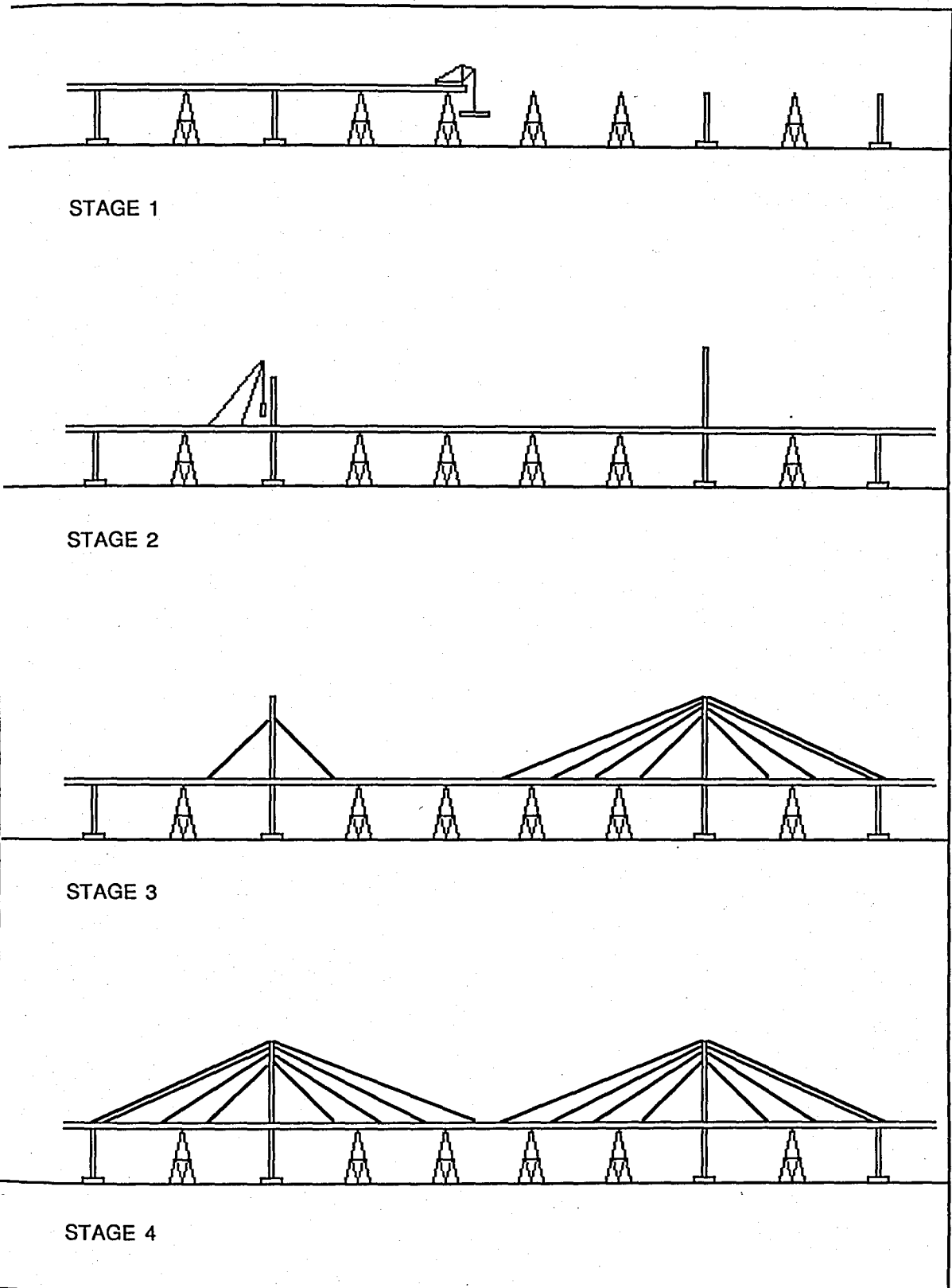

FIGURE 5.3. ERECTION ON TEMPORARY SUPPORTS

*Stage 2.* Erection of the pylons from the deck of the completed girder.

*Stage 3.* Installation of the stay cables. In this stage the cables only need to be tensioned moderately as the final tensioning will take place in the following stage.

*Stage 4.* After installation of all stay cables the temporary supports can be removed and the load transferred to the cable system. During this process the girder will deflect downwards and it is therefore necessary to initially erect the girder in an elevated position to reach the desired final geometry when all dead load has been transferred to the stay cables.

The erection procedure illustrated in *Figure 5.3* offers the advantage that the girder can be erected continuously from one end to the other allowing the transportation of men, equipment, and material on the completed part of the deck. Also, the procedure leads to an efficient control of the geometry and cable tension.

The disadvantage of the procedure is related to the temporary supports that must be used. Thus, in many cases clearance requirements during the construction period will exclude the installation of the necessary number of temporary supports, and even if the clearance requirements are not prohibitive the cost of erecting the temporary supports, often on large water depth in the main span, might be of such a magnitude that the procedure will not be feasible.

Temporary supports can be completely avoided if the bridge is being erected by the free cantilever method, as illustrated in *Figure 5.4*. Here the procedure involves the following stages :

*Stage 1.* The pylons (and the girder units above the main piers) are erected and (temporarily) fixed to the piers.

*Stage 2.* A balanced free cantilevering is initiated using derrick cranes operating on the deck to lift girder units transported to the site on barges.

*Stage 3.* As the cantilevers grow, the stay cables are installed and stressed initially to relieve the bending moments in the girder. Often the cantilever process is completed for one bridge half, before moving the cranes to the other half.

*Stage 4.* The bridge is closed at the main span center and additional loading from wearing surface, railings etc. is applied.

With this procedure it is essential to have a very efficient fixity of the superstructure to the main piers throughout the construction period, as the entire stability depends on this fixity until the end pier is reached. Also, the lateral bending stiffness of the girder must be

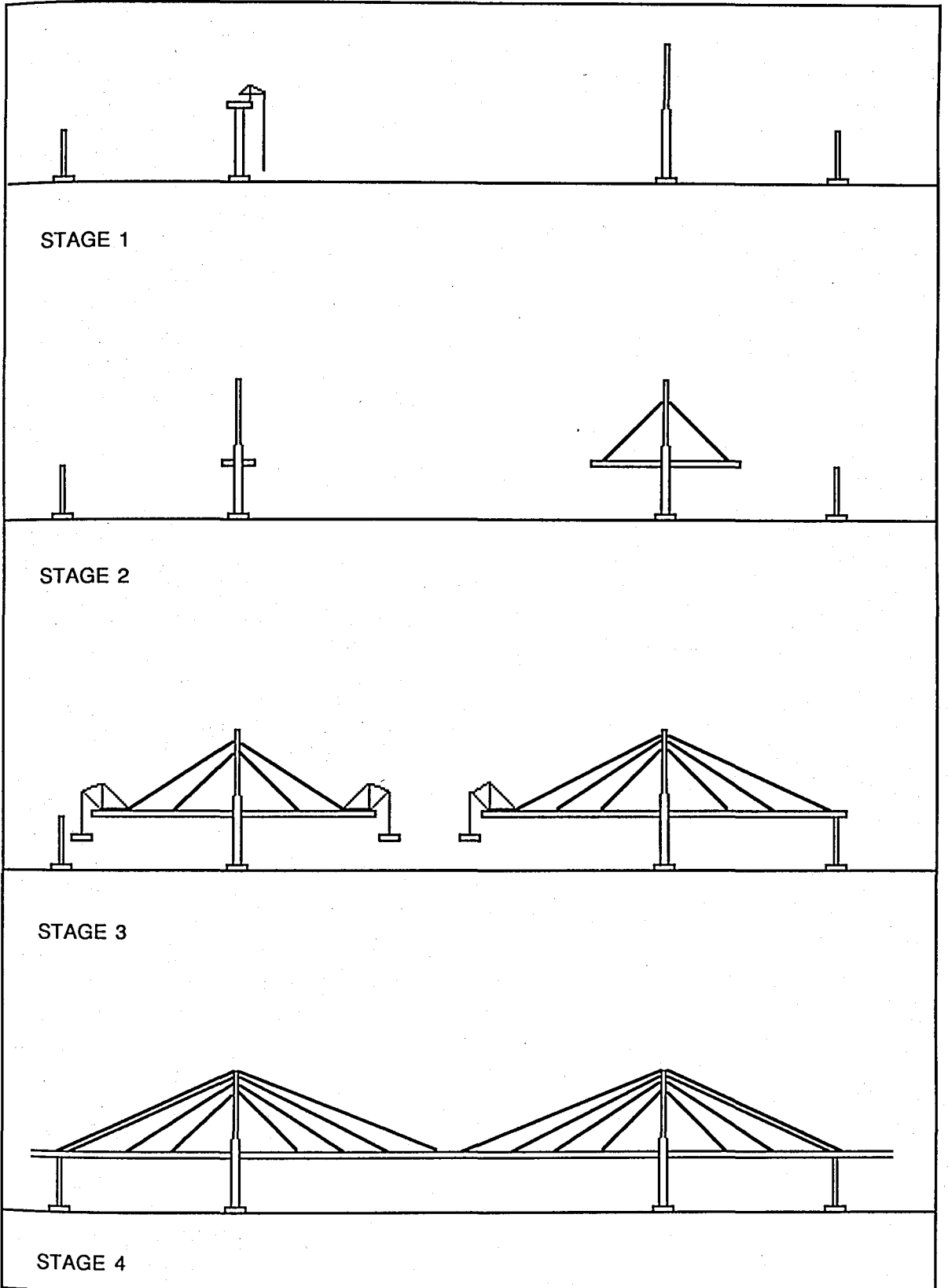

FIGURE 5.4. ERECTION BY DOUBLE-SIDED FREE CANTILEVERING FROM THE PYLONS

sufficient to ensure the stability of the cantilever arm with a length corresponding to half the main span length. Thus, the procedure is especially advantageous in bridges with a large width - to - span ratio of the girder.

If the erection procedure of *Figure 5.4* is going to be used, the distance between the cable anchor points should be chosen to allow a free cantilevering of the stiffening girder from one cable anchor point to the next without requiring a temporary support (e.g. by temporary cables). Thus, also in this respect a multi-cable system is to prefer.

It should be emphasized that cantilevering of a self-anchored cable stayed bridge requires that all girder joints are closed as soon as the girder units are in place to allow the transmission of the normal forces induced during the subsequent tensioning of the stay cables.

In a number of cases the two erection procedures of *Figure 5.3* and *Figure 5.4* have been combined so that the side spans are erected on temporary supports and the main span by free cantilevering, as shown in *Figure 5.5*. In the four stages indicated, the following operations are involved :

*Stage 1.* Erection of the stiffening girder in the side spans using temporary supports, followed by the erection of the pylons as the main piers are reached.

*Stage 2.* One-sided free cantilevering of the main span girder with installation of both the main span stay and corresponding side span stay cable as the relevant anchor points in the main span are reached.

*Stage 3.* After completion of one bridge half the cantilevering of the other half takes place.

*Stage 4.* Closing of the bridge at the main span center.

With this erection procedure the application of temporary supports is limited to the side spans where clearance requirements and water depths seldom will exclude this supports. at the same time it means that the cantilevering of the main span can start from a very stable system comprising the side span girder with support on both the main pier and the end pier. a temporary fixity to the main pier is therefore not required.

The principle of a one-sided cantilevering into the main span will be especially advantageous if the side spans can be erected without temporary supports.

This will be possible if the side span girder has sufficient strength to carry its self-weight as a beam spanning between the end pier and the main pier.

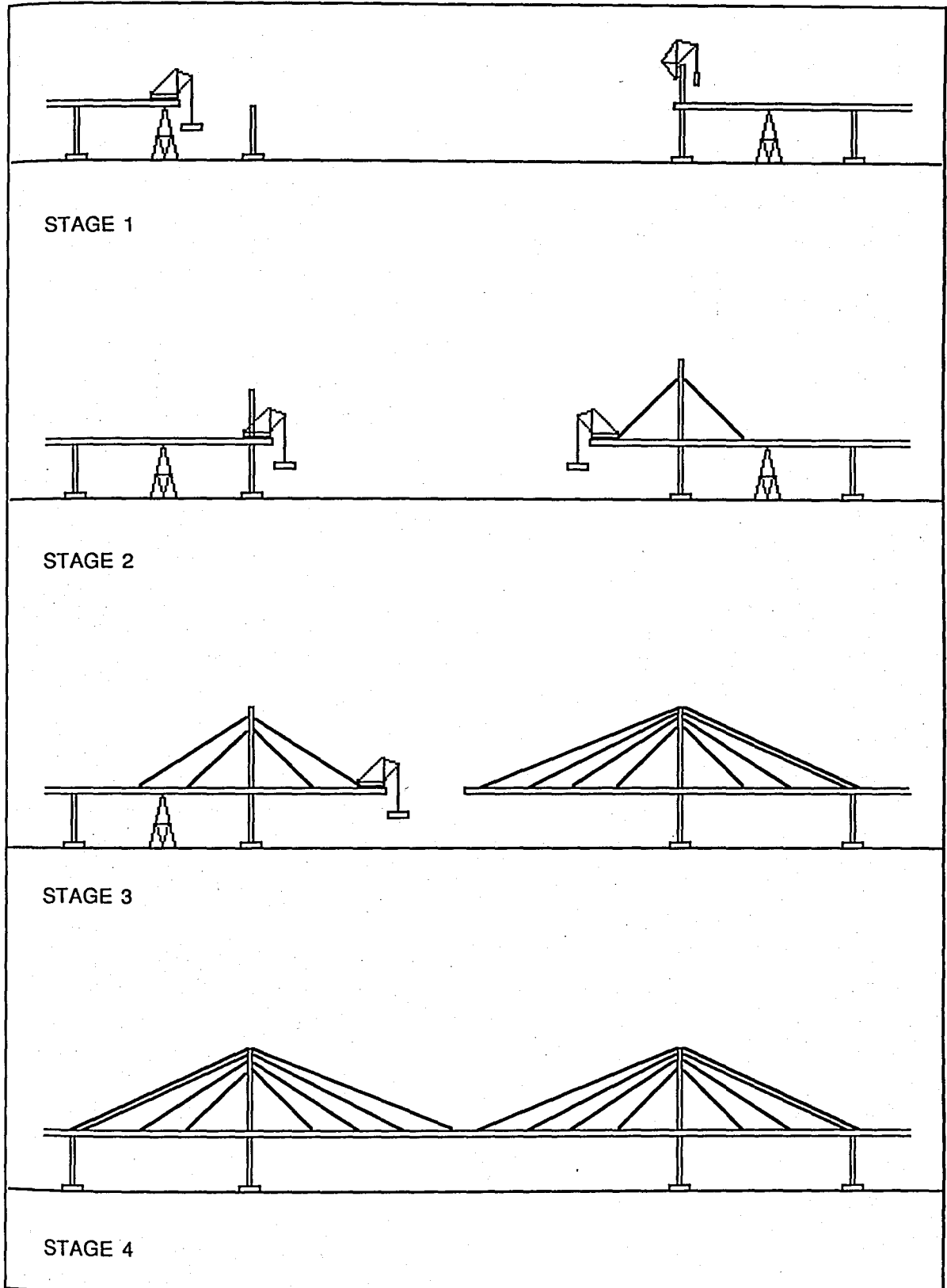

FIGURE 5.5. ERECTION BY ONE-SIDED FREE CANTILEVERING OF THE MAIN SPAN

In bridges with a harp shaped cable system having intermediate supports in the side spans, the procedure of *Figure 5.5* with a one-sided free cantilevering of the main span is the evident solution, as the side spans can be erected initially on the permanent intermediate piers without requiring temporary supports as shown in *Figure 5.6*.

Generally it is very important to plan the erection procedure for a cable supported bridge in such a way that a minimum of temporary provisions and adjustments is required to arrive at the desired final dead load condition.

To illustrate this a proposed erection procedure for a cable net bridge with its continuous top cable, earth as well as self-anchored stay cables, and trajectory cables will be given as an example. In *Figure 5.7* five stages in the erection of the cable net bridge are shown :

*Stage 1.* Illustrates the initial lifting of girder units at midspan following the erection of the continuous top cable by procedures as used for the construction of suspension bridge main cables.

*Stage 2.* Shows the situation after erection of the central part of the stiffening girder corresponding to the part carried by the top cable in the final structure. At this stage the top cable will be close to its final shape and consequently the joints between the girder units can be closed without introducing unacceptable stresses in the following stages. Due to the load applied at the main span center the stiffness of the top cable is considerably increased. This makes the top cable well suited for giving support to the lifting struts and for restraining the pylon tops longitudinally.

*Stage 3.* Indicates the start of the erection of the girder parts supported by stay cables in the final structure. As shown, lifting of girder units might proceed at six different positions corresponding to a double-sided free cantilevering from each pylon and a bi-directional extension of the central suspended part. During this stage the units have to be connected by a full joint to the parts already erected, as normal forces must be transferred through the stiffening girder.

*Stage 4.* Marks the closing of the gaps between the girder parts erected by free cantilevering and the parts suspended from midspan.

By erecting the side spans and the corresponding part of the main span by a symmetrical cantilevering from the pylon it is assured that this portion will be self-anchored, whereas the central portion of the main span will be earth anchored. Thus, the desired division of the structural system into a self anchored part is automatically achieved by the chosen erection procedure.

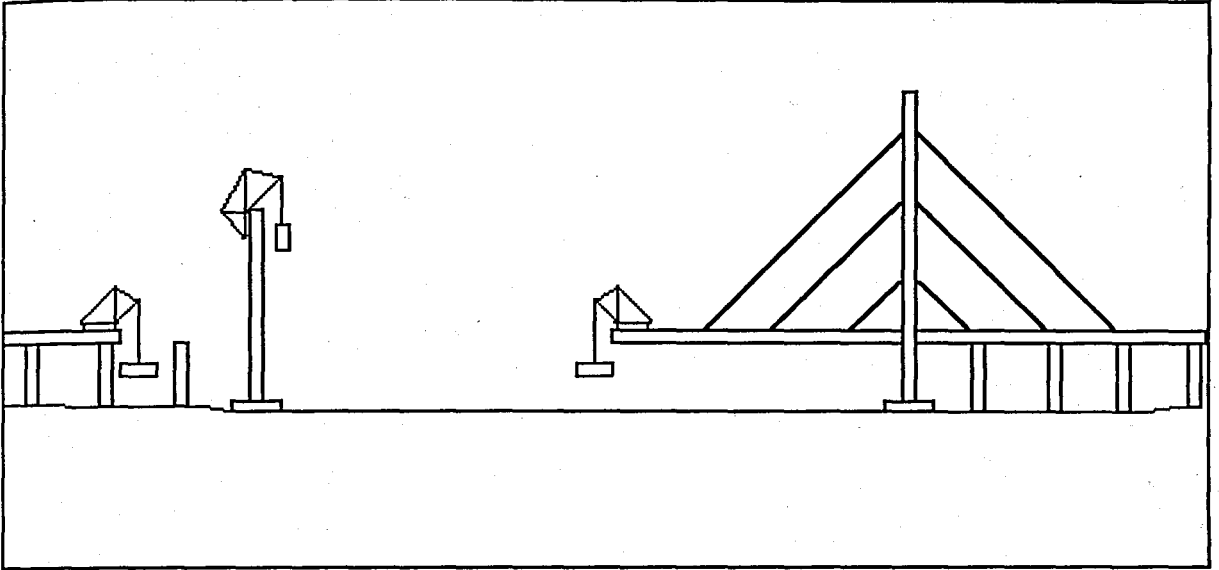

**FIGURE 5.6. ERECTION PROCEDURE FOR A CABLE STAYED BRIDGE**

*Stage 5.* Shows the final system with the trajectory cables added.

To achieve a prestressing of the trajectory cables; these should be erected before the superimposed dead load of surfacing, railings, and other non-structural parts is added. As the additional dead load tends to decrease the sag of the stay cables the trajectory will be tensioned.

This example of the erection procedure for the cable net bridge illustrates how a final dead load condition, that might seem somewhat complicated at first sight, can be reached with a minimum of adjustments and temporary measures. However, this naturally requires a thorough analysis of the entire erection procedure so that each cable is given the correct shape and force when initially erected.

#### 5.4. Construction of Pylons

The methods used during the construction of pylons are generally the same as found in other tower structures. Thus, for smaller pylons as found in cable stayed bridges of moderate size, erection by mobile cranes with high booms or by floating cranes might be found. Erection by land or sea based cranes might also be used for the lower parts of larger pylons [3].

To erect the upper part of larger steel pylons the traditional procedure involves a climbing crane following the pylon as it grows. The crane applied to hoist the prefabricated pylon units into place generally consists of a derrick on a latticed strut attached to both pylon legs.

When well-known tower erection methods are being used, it is essential that the pylon is fixed to the pier and able to stand temporarily as a free vertical beam-column.

Generally the most critical phase in the construction of the pylon occurs in the period from when the pylon is at full height until the first stay cables or cat-walk are erected. In this period oscillations of the pylon in the longitudinal direction of the bridge might be experienced.

From a description of the erection of the Firth or Forth Suspension Bridge in Scotland the following quotation should illustrate the problem [3]:

' In a South-west wind of about 32 km/h the tower began to oscillate considerably, the movement at the top being estimated at several feet. The butt joints were opening and closing at the north and south faces, the opening of the lowest joint amounting to 0.1mm .....

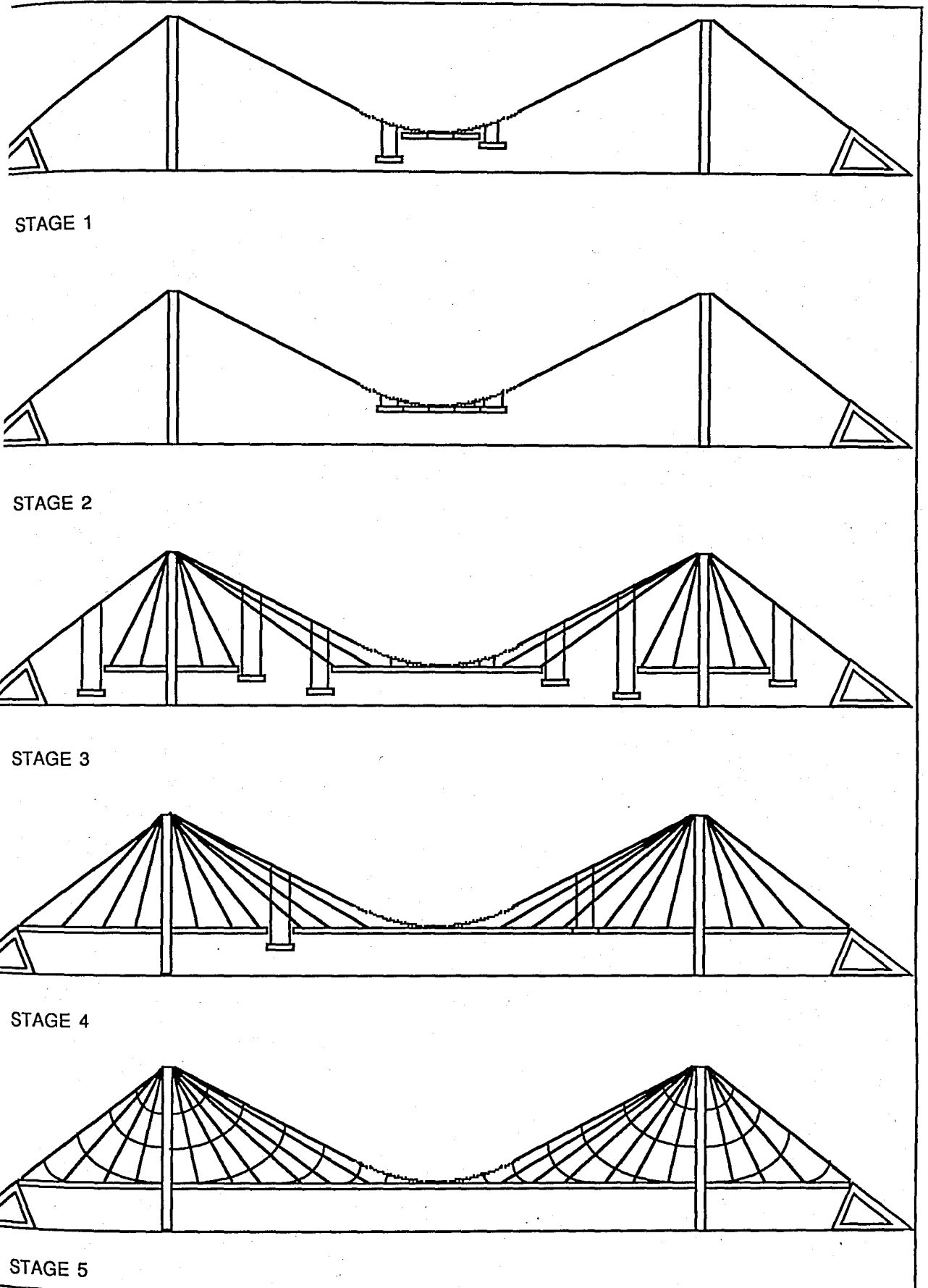

FIGURE 5.7. ERECTION PROCEDURE FOR A CABLE NET BRIDGE

with the tower at its full height and the climbing structure at the top, the sway culminated in a measured double amplitude of 2.3 meters'

The longitudinal oscillations are caused by the slenderness of the pylon in his direction, combined with the large wind areas at the top from the bracing and the climbing crane.

When the cable system, or just the temporary cat-walk, has been erected the pylon top will generally be supported sufficiently in the longitudinal direction of the bridge to eliminate these oscillations.

In the completed structure the pylon must be flexible in the longitudinal direction to be able to follow the displacements of the cable system, and therefore the slenderness can not be chosen freely. As the displacements of the pylon top increase significantly with the side span length, the problems of fulfilling the requirements both during construction and in the final stage will be most severe in bridges with large side -to- span ratios. If both requirements cannot be fulfilled, a temporary support of the pylon in the longitudinal direction might become a necessity.

Such a temporary support was arranged during the construction of the Little Belt Bridge in Denmark. As illustrated in *Figure 5.8* the temporary support consisted of bracing cables leading from one end pier to the pylon at a height of 85 meters, across the main span to the other pylon, and further to the other end pier. The bracing cables were added as soon as the pylons reached the relevant height and consequently they were fully effective when the pylon top and the upper strut were cast. To allow an adjustment of the tension in the bracing cables tie-down ropes were arranged at both pylons and at the end piers.

In the case of the Little Belt Bridge, the pylons were made of concrete which might accentuate the cantilever problem as a relatively modest amount of vertical reinforcing is required in the completed structure due to the effective prestressing by the vertical compressive force from the cable system.

To reduce the oscillations of the free standing pylon it is not necessary to install a continuous bracing cable leading from one anchor block to the other as in the case of the Little Belt Bridge. Thus, for the 215 meters high concrete pylons of the proposed Great Belt Suspension Bridge one-sided stabilizing cables are shown in *Figure 5.9* were planned to be installed. With this system the required tensioning of the bracing cables will bend the pylons towards the main span center during erection of the stiffening girder, an outwards bending of the pylon is favorable to achieve a pylon with zero bending in the final condition.

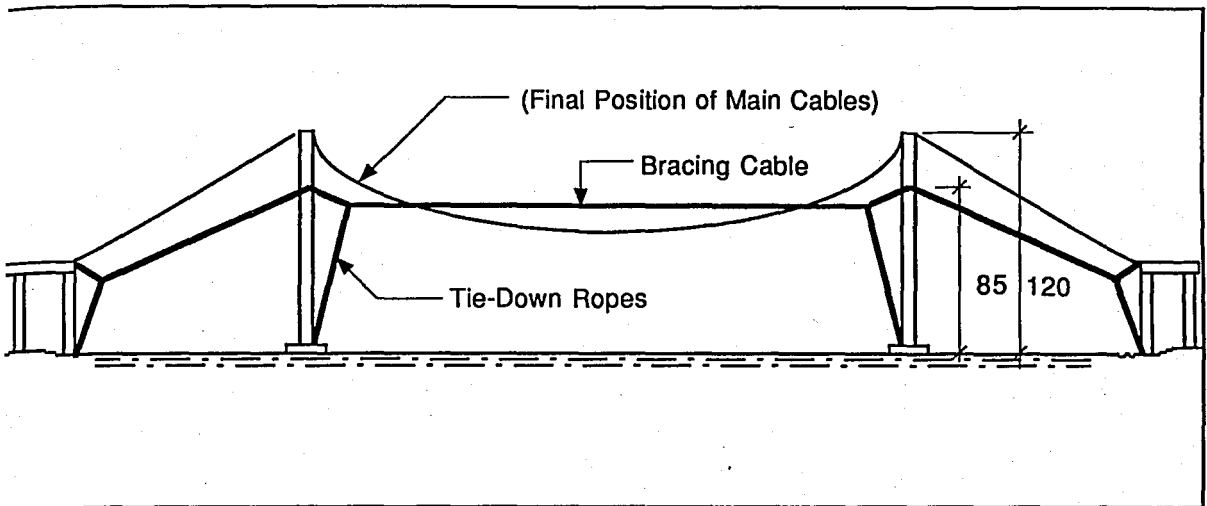

FIGURE 5.8. BRACING CABLES OF THE LITTLE BELT BRIDGE, DENMARK (In meters)

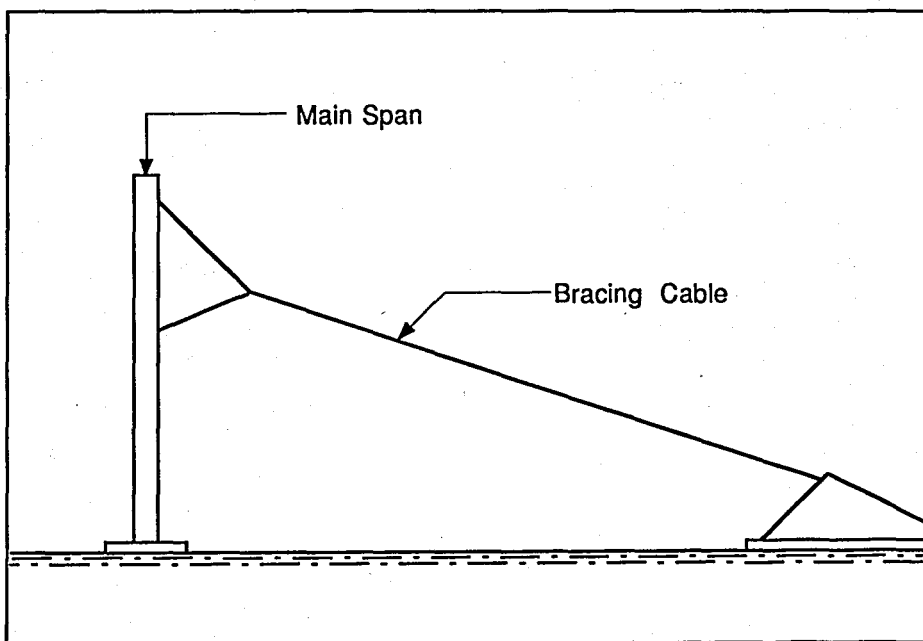

FIGURE 5.9. PROPOSED ARRANGEMENT BRACING CABLES OF THE GREAT BELT BRIDGE PROJECT

## 5.5. Erection of Cables

For the erection of cables, a number of procedures are used depending on the type and size of the cable. The largest cables to be found within cable supported bridges are the main cables of suspension bridges [3].

The traditional method of erecting suspension cables is the air spinning method shown in *Figure 5.10* that has now been used for more than 100 years. This method can be described as an *in situ* method because the cable is actually built up from the single wires delivered to the site in coils.

In a reeling machine the wires of the coils are transferred to larger reels containing a total wire length corresponding to 10-20 times the distance from one anchor block to the other. After completion of each reel it is brought to the reel stand where the unreeling takes place.

From the reel stand, positioned near the anchor block, the wires are taken through the counterweight tower and around the spinning wheel back to the anchorage. As the spinning wheel is carried across from one anchorage to the other by an endless hauling rope, four or eight wires will be added to the cable (depending on whether two or four loops are carried by the spinning wheel). As the lower wires are connected to the anchorage at one end these stationary wires are designated 'dead wires', whereas the 'live wires' going from the spinning wheel to the reels move with twice the speed of the spinning wheel. When the spinning wheel has reached the other anchorage the loops are lifted off the wheel by hand and connected to the strand shoes.

Equal stress in all wires is assured by a sag adjustment during and immediately after each run of the spinning wheel. This sag adjustment is the main cause of the weather sensitivity of the air spinning method, as the adjustments can only be made if the wind speeds are less than approximately 50 km/h. Depending on whether a reel stand is available at both anchor blocks or only at one, the spinning wheel will either return with a new set of wires, or return empty.

When a reasonable number of wires (of the order of 300) has been pulled across by the spinning wheel, they are bundled into a strand by aluminum bands. The reason for this bundling into strands is to stabilize the partially erected cable to avoid a tangling of the individual wires and to allow an accurate sag adjustment of the sag it is generally necessary to work at night when a uniform temperature can be expected. The parallel-wire strand method involves the erection of an entire prefabricated strand containing approximately one hundred 5 mm wires and having the full length of the main cable between anchor blocks.

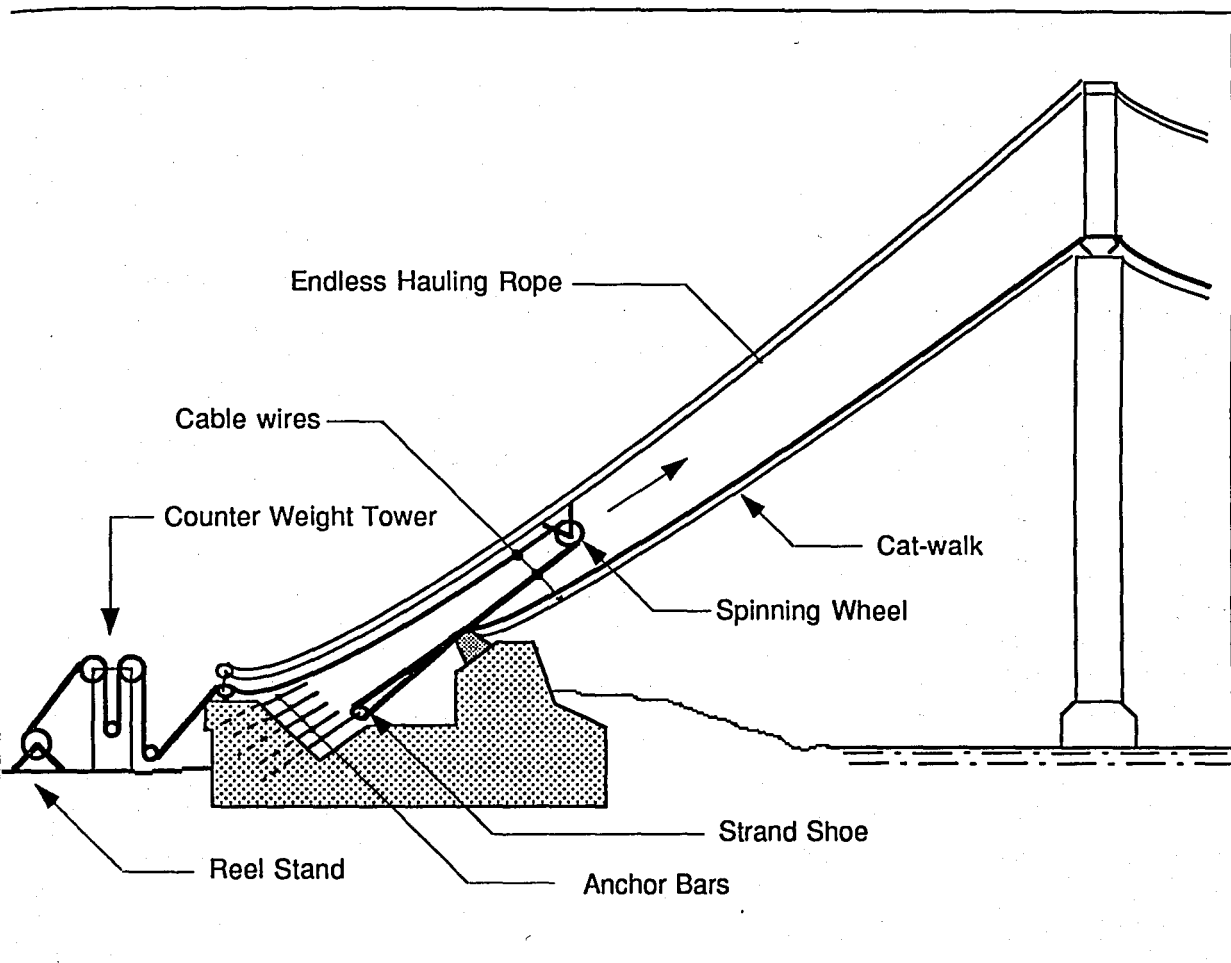

FIGURE 5.10. THE AIR SPINNING METHOD (Verrazano Narrows Bridge, USA )

The parallel-wire strand with sockets at both ends is delivered to the site on large reels weighing up to 40 tons according to present practice. After positioning of the reels in an unreeling machine at one of the anchor blocks, the parallel-wire strand is pulled across to the other anchor block by means of a hauling rope. As the strand moves along, it is supported by rollers placed on the cat-walk beside the final position of the main cable.

The first strand erected is used as a standard strand for the sag adjustment of all later strands. Consequently, the adjustment of the first strand must be made with the greatest care.

In the initial stage of the main cable erection, the air spinning method and the parallel wire strand method differ significantly, but when the strands are in place the following operations will be very similar for the two methods.

During the built up of the cable, the strands are arranged in a hexagonal pattern, either vertical (with the apex at top and bottom) or horizontal (with sides top and bottom), as shown in *Figure 5.11*. Both patterns have been used for very large main cables.

The trend seems to be moving towards preferring the vertical arrangement, as this allows the installation of vertical spacers between each row of strands. With such spacers the correct positioning of the strands is achieved efficiently. On the free length of the cable the spacers are only used temporarily, whereas they might be permanent in the saddles to prevent the strands from interfering in these regions characterized by a considerable side pressure. For these reasons the vertical hexagonal arrangement has been chosen for all the major Japanese suspension bridges using the parallel-wire strand system.

For parallel-wire cables erected by either the air spinning method or the parallel-wire strand method, a compaction of the cable is required when all strands are in place. The compaction is made by a compacting machine squeezing the wires together by means of hydraulic jacks. during compaction the shape of the cable is changed from a hexagonal to an almost circular configuration.

The efficiency of the compaction is generally measured by the percentage of voids in the cable. The theoretical minimum percentage of voids in a perfectly compacted cable is 9.3 per cent, but practical experience shows that the percentage of voids after compaction will remain within the interval 17-23 per cent. This is mainly due to the fact that true parallelism of all wires cannot be achieved.

As compaction proceeds the cables are tightly bound with temporary steel straps at a distance apart of typically 750 mm.

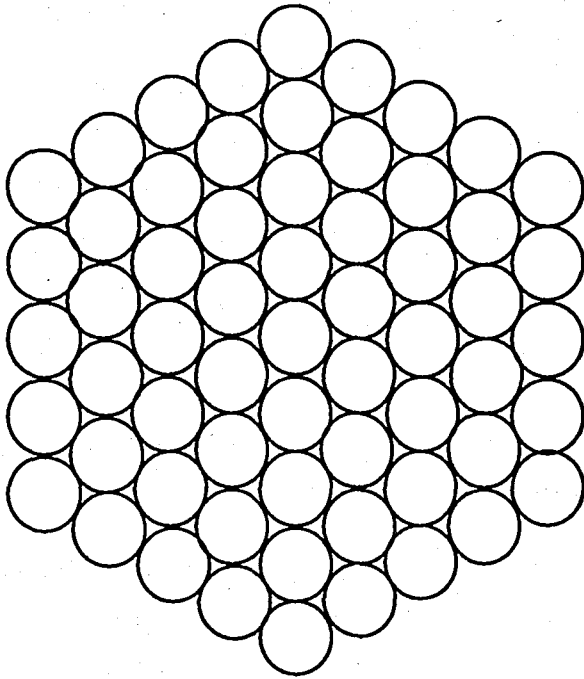

VERTICAL HEXAGONAL ARRANGEMENT

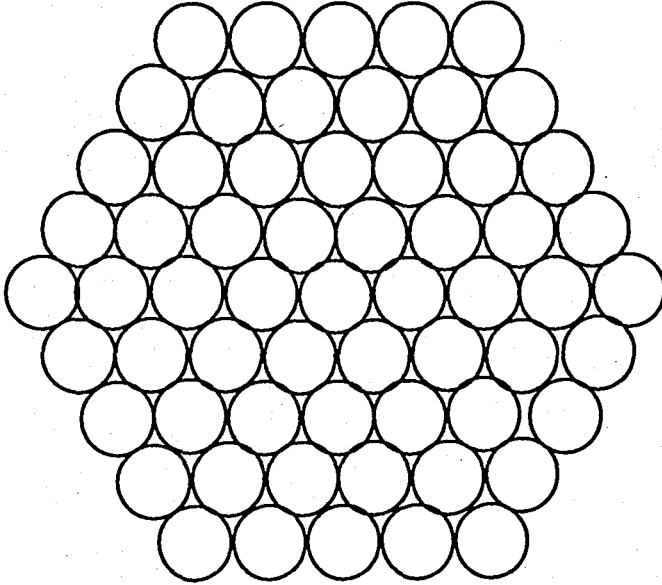

HORIZONTAL HEXAGONAL ARRANGEMENT

**FIGURE 5.11. ARRANGEMENT OF STRANDS IN SUSPENSION BRIDGE MAIN CABLES**

After completing compaction, the cable bands are installed and clamped together by means of high-tensile steel bolts. Due to the fact that the percentage of voids inside the compacted cable is approximately twice the theoretical minimum, mutual displacements between the wires might take place as time goes by and it is therefore necessary to retighten the clamping bolts on subsequent occasions. This retightening is also required during the erection of the stiffening girder as the Poisson effect tends to reduce the cable diameter when the tension is increased.

Subsequently, the cable is wrapped between the cable bands. In all major bridges the wrapping has been made by a soft annealed galvanized wire, typically with a 3.5 mm diameter. The wire is wrapped under a tension corresponding to a stress of approximately  $150 \text{ N/mm}^2$  by means of a wrapping machine moving along the cable.

After installation of the cable bands the cable system of the suspension bridge is completed by erecting the hangers. In most cases the hangers are lifted vertically to their final positions after transportation to the site on a barge. However, in cases where the main cable is made from parallel-wire strands the equipment used during installation of these strands might also be used to transport the hangers along the cat-walk and complete their erection from the top to bottom.

Turning to the other main type of cable supported bridge, the cable stayed bridge, it is characteristic that here the cross section and the length of the cables are generally much smaller than for the suspension bridge main cables, and this naturally leads to different erection procedures.

Multi-strand stay cables have been erected by means of cat-walks in many cases. Because the stay cables have to be almost straight, longer cat-walks must be supported intermediately - in contrast to the suspension bridge case where a 'natural' sag of the cat-walk is at hand.

The intermediate support of cat-walks for stay cable erection can either be established by a supplementary cable support or by temporary lattice towers standing on the bridge deck.

After erection of the cat-walk the strands are unreeled one by one and pulled from the girder anchor point to the pylon anchor point, or over a pylon saddle to a girder anchor point in the adjoining span. When all strands are in place, the cat-walk can be used for the finishing work, such as application of steel straps and mastix filling as well as for painting. However, for the erection of stay cables the application of a cat-walk is somewhat troublesome and costly, as the amount of cable steel to be erected is relatively small.

Also, the fact that a new cat-walk has to be erected every time a new cable anchor point is reached, makes the method rather slow.

Therefore, in some cases, the erection of multi-strand stay cables has been made without a cat-walk. As an example, the stay cables of the Deisburg-Neuenkamp Bridge in Germany were erected by initially stretching out on the bridge deck each multi-strand cable with its corresponding cable saddle. Then the saddle was lifted into place at the pylon and at the same time the strands were anchored to the stiffening girder.

The initial tensioning of a multi-strand cable is generally performed in two stages. The first tensioning is made during the installation of the individual strands for the sake of adjusting the sag to ensure equal stress in all strands. Then after all strands are in place, the entire stay cable is tensioned by jacking upwards the cable saddle on the pylon

The two step tensioning described for multi-strand stay cables complicates cable erection and thus represents another drawback of the early cable stayed systems with few concentrated stay cables. Consequently, considerations regarding the cable erection will also lead to the preference of multi-cable systems containing mono-strand cables. By application of mono-strand cables each stay cable can generally be fabricated in full size in the shop.

A large degree of prefabrication is achieved when using parallel wire cables with sockets and polyethylene tubes mounted in the factory. After completion the cables can be reeled for transportation.

For bridges with stay cable lengths up to 200 meters, as found in the present practice within cable stayed bridges, the reels can be handled by available equipment, and transportation to the bridge site can take place by truck, train or ship. However, if cable stayed bridges with considerably larger spans than those of today are going to be constructed handling problems might exclude the same degree of prefabrication in shops situated remotely in relation to the bridge site.

After arrival at the bridge site the cable reels are mounted in a reel stand that might be situated on the bridge deck, at the abutments or below the bridge. To counteract plastic strains that inevitably occur in the polyethylene tubes during reeling the cable should preferably be stretched in a straight position, for some time before being installed.

For the procedure leading from the unreeling of the cable to the final installation in the bridge a number of different solutions are found. A procedure involving a minimum of temporary staging consists of stretching the unreeled cable on the bridge deck below its final position and then lifting one end by a crane to the anchor point at the pylon.

With this procedure the cable will show a considerable sag immediately after being connected to the stiffening girder and the pylon due to the fact that the lifting equipment only allows a very modest tensioning of the cable. Thus, the final tensioning by jacks will require large movements between the socket and the adjacent structure.

A significant reduction of the initial sag can be achieved by supporting the cable on a cat-walk. In this case it is convenient to stretch the cable in front of the cat-walk, so that the cable can be hauled without having to be horizontally curved. To allow the movements associated with the haling operation the cable is supported by rollers on the bridge deck and the cat-walk.

With the large number of intermediate supports on the cat-walk the stay cable will be almost straight when initially installed and the final tensioning therefore only requires modest displacements corresponding to the elastic strains in the cable.

The main disadvantage of this procedure illustrated in is the costly erection (and subsequent demolishing) of the cat-walk. This feature is especially pronounced in connection with the erection of parallel wire cables in polyethylene tubes, as very little work has to be done after the cable is in place on the cat-walk (in contrast to the suspension bridge case where the cat-walk is used during many operations such as compaction, wrapping, installation of cable bands, and erection of hangers).

The advantages related to an initial straightness of the stay cable can also be achieved with a procedure as illustrated in *Figure 5.12*. Here the stay cable is supported by trolleys running on a guide rope above the final position of the stay.

In *Figure 5.12* is shown a case where the cable reel is positioned on a barge immediately under the relevant cable anchor point. Thus, the cable is pulled vertically to the stiffening girder and over a curved, trunk-shaped slide to give a gentle change of direction. However, with this procedure the cable is taken directly from the reel to its final position so that the plastic strains in the polyethylene are not relieved through an intermediate stretching.

The arrangement of *Figure 5.12* with the cable reel on a barge is especially attractive in connection with the erection of heavy stay cables as the considerable weight of the reel stand with the full cable to a guide rope can also be combined with a reel stand based on the stiffening girder.

After initial installation of the stay cable by one of the procedures described above final tensioning is performed by jacking the socket at one end. In most cases the jacking operation is made at the girder due to the better access.

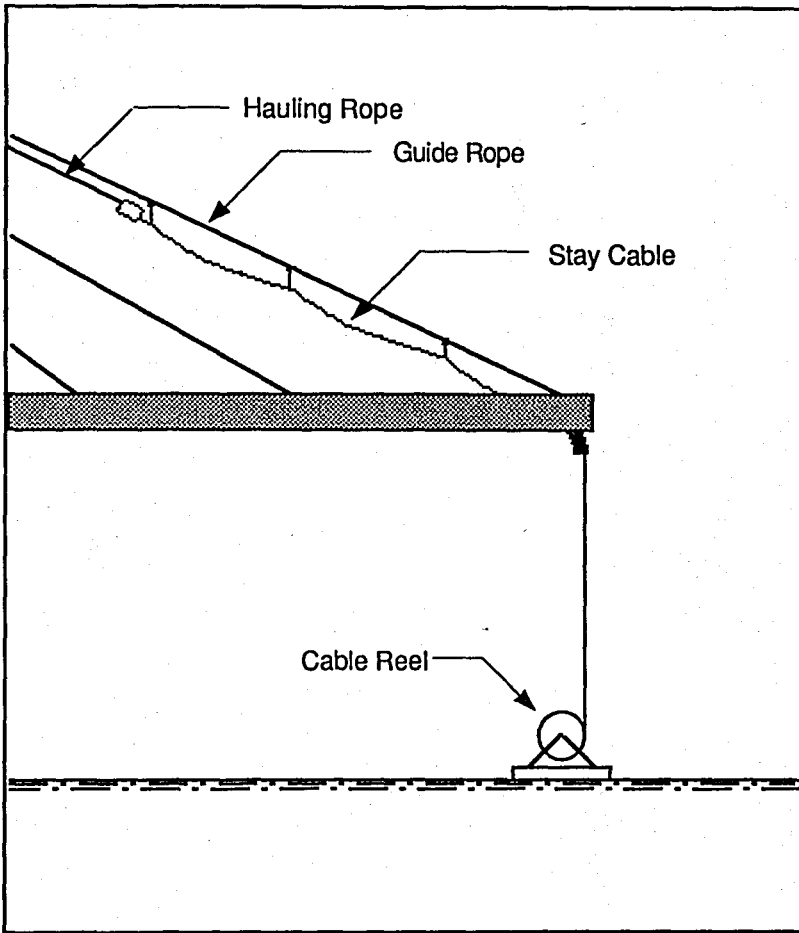

**FIGURE 5.12. PARALLEL-WIRE CABLE SUPPORTED BY TROLLEYS**

## 5.6. Erection of the Stiffening Girder

The procedure to be used for the erection of stiffening girders or trusses depends to a large degree on the type of cable system, as was explained in connection with *Figures 5.1 to 5.6*.

In some cases the erection of stiffening trusses in suspension bridges has been made as a traditional truss erection where each chord and diagonal member is lifted into place by a crane based on the completed part of the bridge deck. However, the advantages of having a completed earth anchored cable system with a large bearing capacity are not fully utilized during the erection of the stiffening truss. A much more efficient use of the cable system is found in cases where very large erection units are lifted into place by application of lifting struts, supported by the main cable as illustrated in *Figure 5.13*.

The lifting struts are generally provided with wheels to allow removal from one position to another on the main cable. However, during the lifting operations the struts have to be lowered onto the main cable and locked to avoid longitudinal displacements caused by the pull of the lifting ropes [3].

The hoisting engines are positioned on the pylon, as indicated in the figure, and this allows the application of very powerful engines so that a very large lifting capacity can be achieved. Thus it is possible to lift erection units weighing up to 450 tons and having the full width of the truss or girder and a length of 20-30 meters.

In modern suspension bridges with a stiffening girder made as a streamlined box girder the application of lifting struts will always be found as a rational fabrication inevitably leads to large erection units.

The erection units are generally transported to the bridge on barges. However, at the construction of the Severn Bridge in Great Britain the box sections were provided with watertight bulkheads, so that the unit itself could float, eliminating the application of barges. Although this seems to be a very elegant solution, it did introduce some problems during the subsequent field welding of the box girder joints due to impurities in the grooves. Thus, in suspension bridges with streamlined box girders following the Severn Bridge, transportation on barges has again been utilized.

At the Severn Bridge erection only a single lifting strut was used. This gave a simple but somewhat unstable support of the erection unit so that the primary lifting ropes had to be supplemented by inclined ropes to achieve aerodynamic stability and allow adjustments of the longitudinal slope.

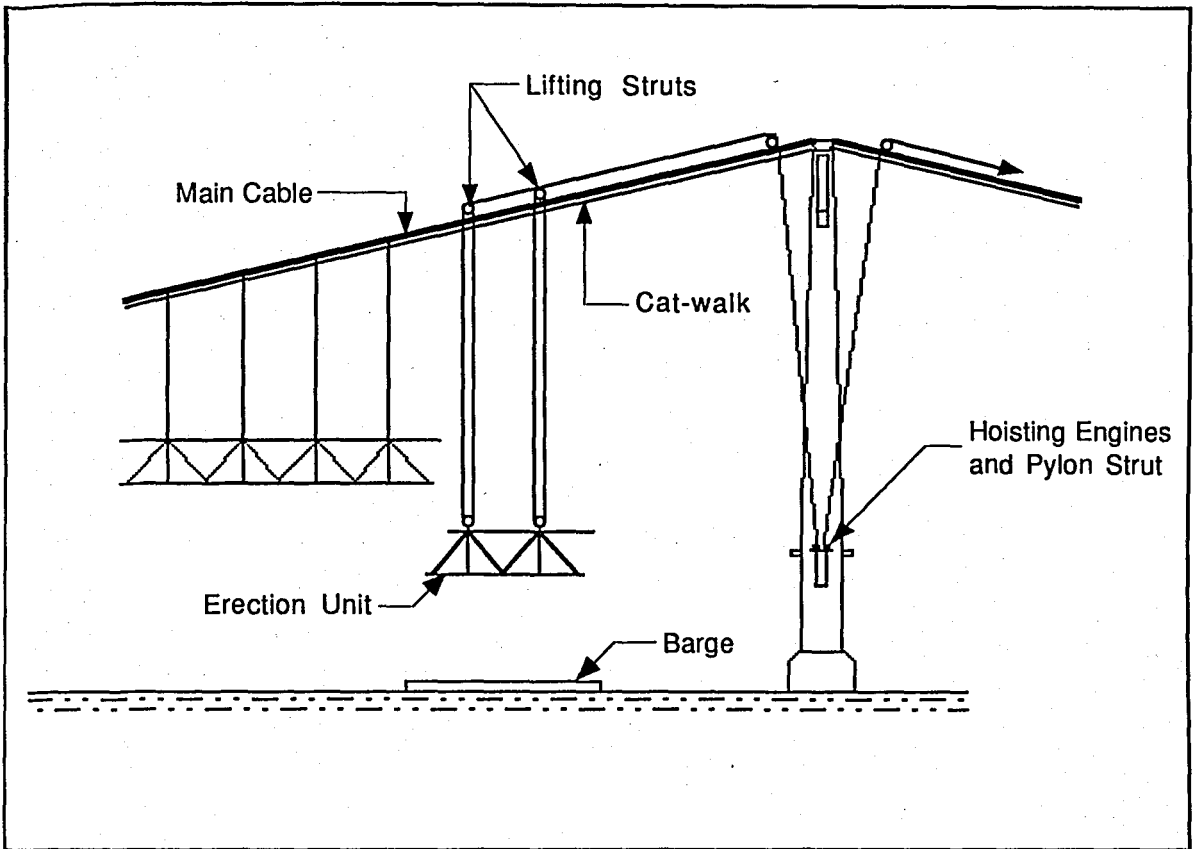

**FIGURE 5.13. ARRANGEMENT OF LIFTING STRUTS AS USED IN THE VERRAZANO NARROWS BRIDGE**

With two lifting struts the erection unit will be lifted at four points introducing a statical indeterminateness. However, by a special arrangement of the lifting ropes it is possible to assure an equal pull in all ropes.

As an example *Figure 5.14* shows the arrangement applied at the Little Belt Bridge erection. Here the lifting strut was provided with a clamp allowing the lifting rope to be locked to the strut. With the clamp left open an equal force in the lifting ropes was assured, but with a locked clamp it was possible to have different forces in the lifting ropes on either side of the clamp. Thus, during the lifting operation one of the struts had its clamp left open and the other the clamp locked.

After completion of the lifting operation, the permanent hangers are connected to the unit, and the lifting struts can then be moved to a new position. To assure that the stiffening girder or truss is moment free in the dead load condition, the erection units are generally suspended from the main cable without closing the joints throughout the erection period. However, it might be necessary to make temporary joints between the units to achieve aerodynamic stability of the partially erected stiffening girder.

The application of lifting struts is restricted to bridges with earth anchored cable systems, but equally large lifting capacities can be achieved by the use of floating cranes. Thus, when local conditions favor the application of floating cranes, large girder units can also be used in cable stayed bridges.

Floating cranes were also used during the erection of the Theodor Heuss Bridge in Düsseldorf, and here a free cantilevering was used in the main span, as indicated in *Figure 5.15*. Each erection unit had a length corresponding to the distance between the cable anchor points in the stiffening girder. The weight of the erection units varied between 280 tons and 360 tons

However, during the erection of Theodor Heuss Bridge in Germany a serious accident, leading to the destruction of an entire erection unit, occurred and this event inevitably caused repercussions for the procedure involving erection of large units by floating cranes. Thus, in the following years it was generally preferred to use an erection procedure based on application of smaller units lifted by derrick cranes positioned at the tip of the already erected part of the stiffening girder.

Generally, the lifting capacity of derrick cranes is considerably smaller than the capacity of lifting struts or floating cranes. Thus, the maximum lifting capacity of derrick cranes used for the erection of cable stayed bridges will hardly exceed 150 tons. It is therefore necessary to use smaller erection units and accept a larger number of erection joints.

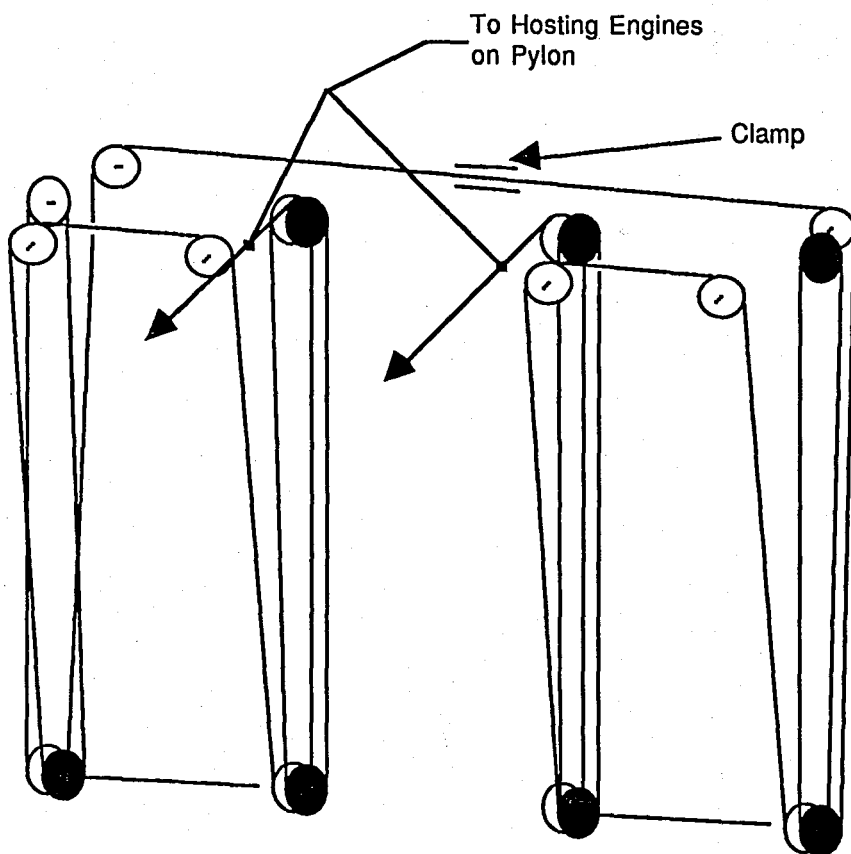

**FIGURE 5.14. SCHEMATIC DELINEATION OF THE LIFTING ROPE ARRANGEMENT OF THE LITTLE BELT BRIDGE**

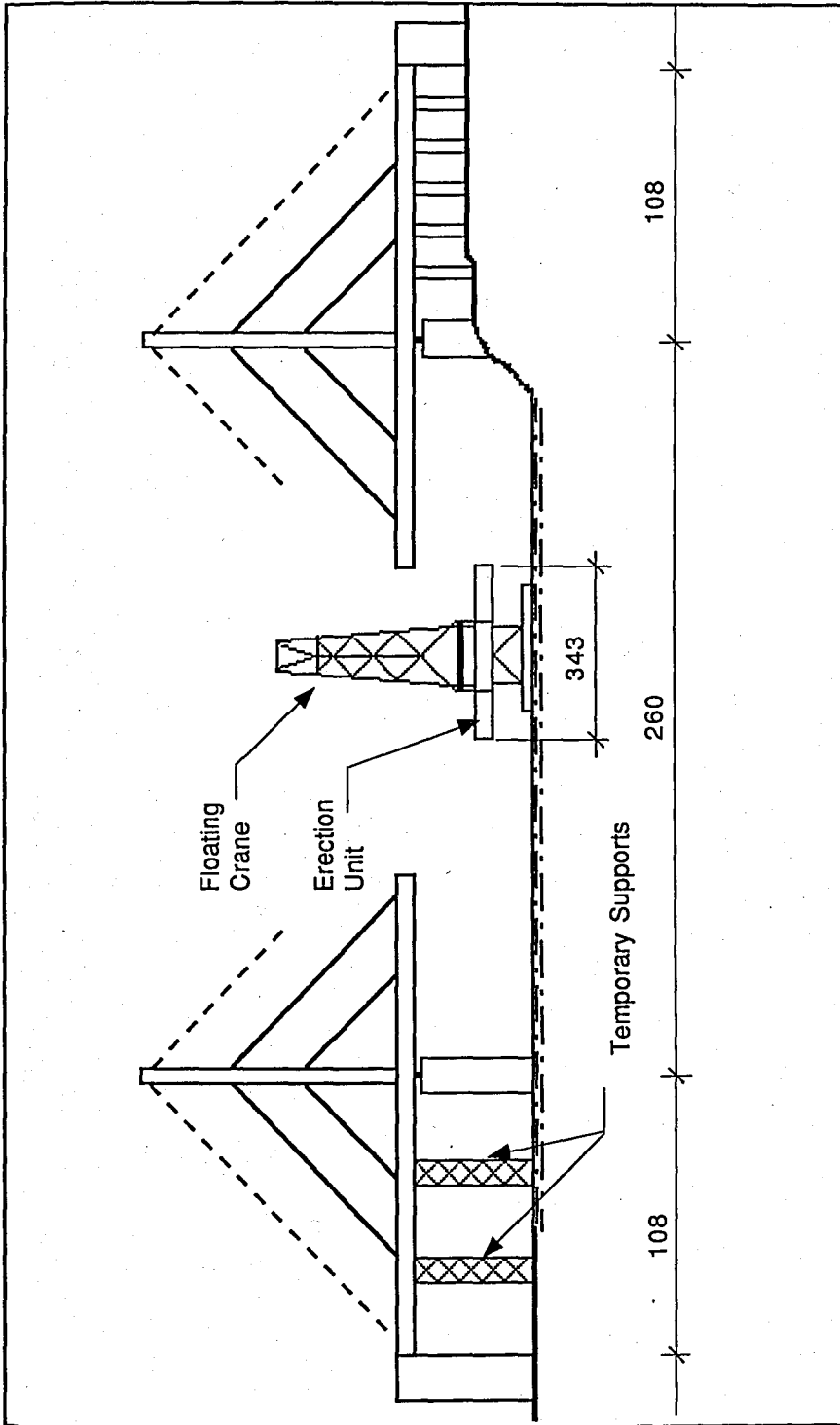

FIGURE 5.15. ERECTION OF THE THEODOR HEUSS BRIDGE, GERMANY (in meters)

For bridges with a stiffening girder of concrete special problems arise as the very favorable effect on the moment capacity due to the compressive force from the horizontal stay cable components is not available at the tip of the girder. At the same time the heavier concrete girder induces a larger cantilever moment than found in stiffening girders of steel.

Temporary erection stays have also been used in cable stayed bridges with few stay cables, and consequently a considerable distance between the cable supported points of the stiffening girder. In these bridges an over stressing might occur either in the girder section or in the last erected stay cable during a free cantilevering from one cable anchor point to the next. In such a case a temporary erection stay, as shown in *Figure 5.16*, might be installed to reduce both the bending moments in the stiffening girder and the tension in the permanent stay cable.

Alternatively, the cantilevered part of the stiffening girder might be supported by a secondary cable system comprising a temporary pylon with a set of temporary erection stays, as illustrated on *Figure 5.17*. With this arrangement, the negative moment in the stiffening girder is reduced, whereas the tension in the permanent stay cables remains practically unchanged. Thus, this arrangement is only applicable if the problem of over stressing is confined to the stiffening girder.

As a closing remark it will be emphasized that temporary measures in the form supports, stays, and pylons used only during erection are costly as they have to be fabricated, erected, and demolished before completing the construction. It is therefore highly recommendable that aspects regarding the erection are taken into consideration in the very early design phase so that the main layout of the structure can be chosen to minimize the amount of temporary structural members.

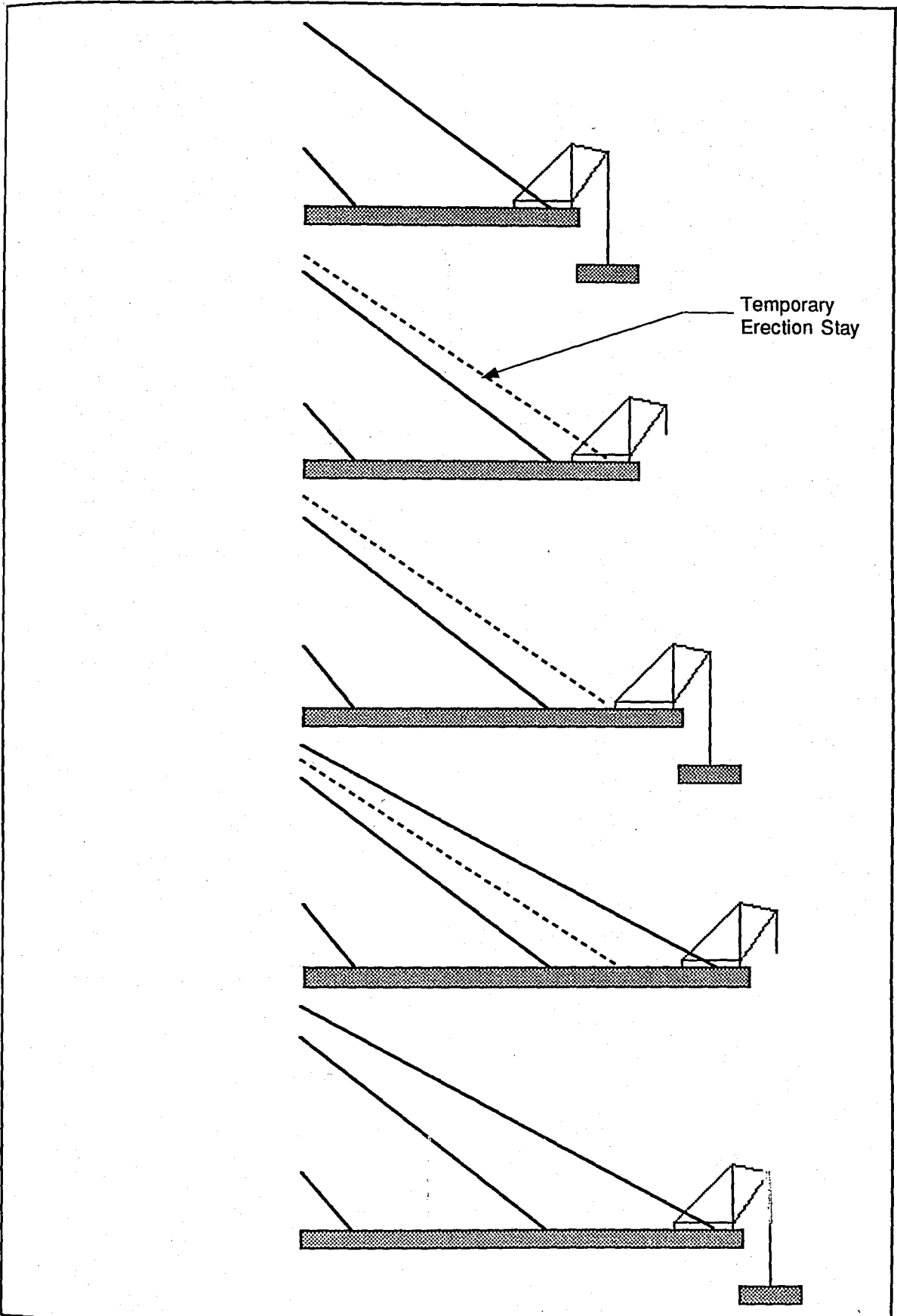

FIGURE 5.16. APPLICATION OF A TEMPORARY ERECTION STAY

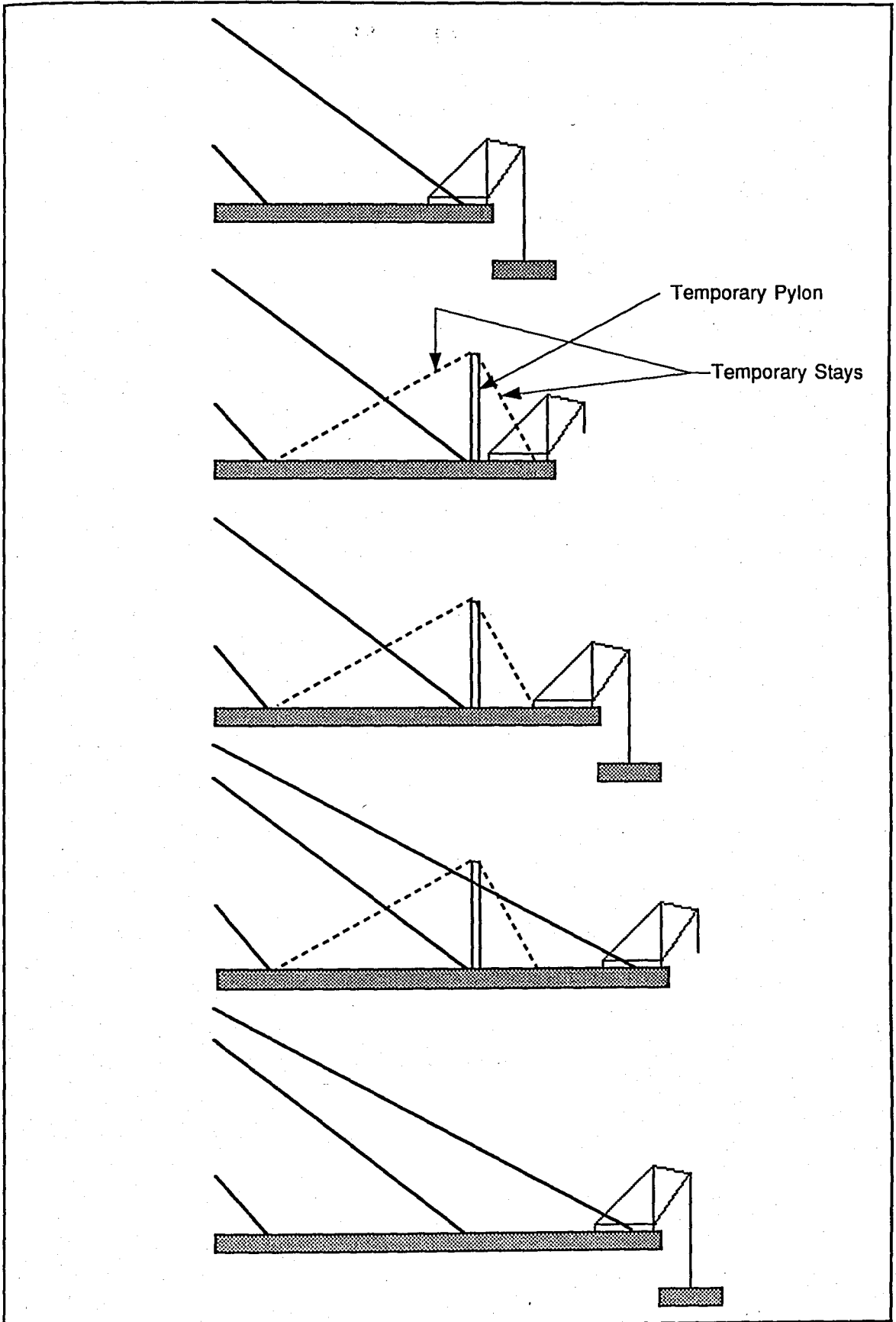

FIGURE 5.17. TEMPORARY CABLE SYSTEM

## 6. ECONOMIC EVALUATION

### 6.1. Introduction

The selection of a specific type of bridge to cross a river, ravine, or highway is not an automatic determination. Many factors must be considered before a final decision is made. In some instances, the factors affecting the design are similar to, if not the same as, those previously considered at another location or site, so several bridges of the same type are chosen [6].

The principle factors to be considered are the relationship of span lengths of various segments of the bridge, the number of piers and placement for safety, the aesthetic considerations for the site, and, finally, the relative cost of bridges of comparable acceptable proportions and type.

Many types of bridges share similar aesthetic and safety considerations, but relative cost of bridges depend on the number and length of spans and number of piers that affect the method of construction. Studies of comparative costs of different type of bridges are few; consequently, a design engineer must perform a detailed investigation of the economics of the total structure until sufficient data is available to make general decisions quickly.

The contractor also lacks specific data on which the base cost estimates and must rely on the detailed design drawings and written specifications for this basic information. Therefore, to arrive at a realistic cost estimate, it is advisable for the designer and contractor to communicate ideas at an early stage in the design process. The method of fabrication and erection can affect both the design and costs and may decide which bridge is the most economical. Contractors must be willing to study and evaluate various methods of erection in order to arrive at a meaningful cost estimate.

## 6.2. Economic Studies

The open competitive design system that exists in Germany has produced numerous feasibility studies that have resulted in actual construction of many cable-stayed bridges. The bridges have main spans ranging in length from 150 to 370 meters. This span range was determined to be economical in the postwar period when many damaged bridges were replaced.

Often a survey and study of existing bridges can reveal meaningful data with respect to the general application of a particular type of bridge and the geometrical proportions best suited to that application. In his survey of the bridges in Germany, Thul compared the center span length to the total length of the bridge for three-span continuous girder bridges, cable-stayed bridges, and suspension bridges, as indicated in *Figure 6.1*. This investigation may be considered a general study on the economical range of applications for the various types of bridges surveyed [6].

Limits of economical application appear to be 210 meters for the center span of a three-span continuous girder bridge, with ratios of center span to total length ranging from 30 to 50 per cent. The suspension bridge begins to be economical for a center span of 305 meters, with a ratio of center span to total length ranging from 60 to 70 per cent. The cable-stayed bridge fills the void left by the continuous girder and suspension bridges in the range of center span from 210 to 305 meters with a corresponding center-to-span-total-length range of 50 to 60 per cent.

In his comparative study, Thul has shown that the cable-stayed concept can be economical for bridges with intermediate spans. However, with greater experience in design and construction, the application of longer main spans of cable-stayed bridges has increased. Because other studies have indicated that longer center spans for cable-stayed bridges are possible, the supremacy of the conventional suspension bridge may well be challenged.

In another study of the economics of cable-stayed bridges with respect to other bridge types, a comparison was made of the weight of structural steel in kilograms per square meters of roadway deck versus center span length. The study was made for girder bridges, suspension bridges, and cable-stayed bridges using an orthotropic steel superstructure. The data are presented graphically in *Figure 6.2* and are result of a study by P. R. Taylor, a Canadian engineer [6].

A comparison of steel deck weights indicates that the cable-stayed bridge again fills the void between the continuous girder and suspension bridges. The data for the girder

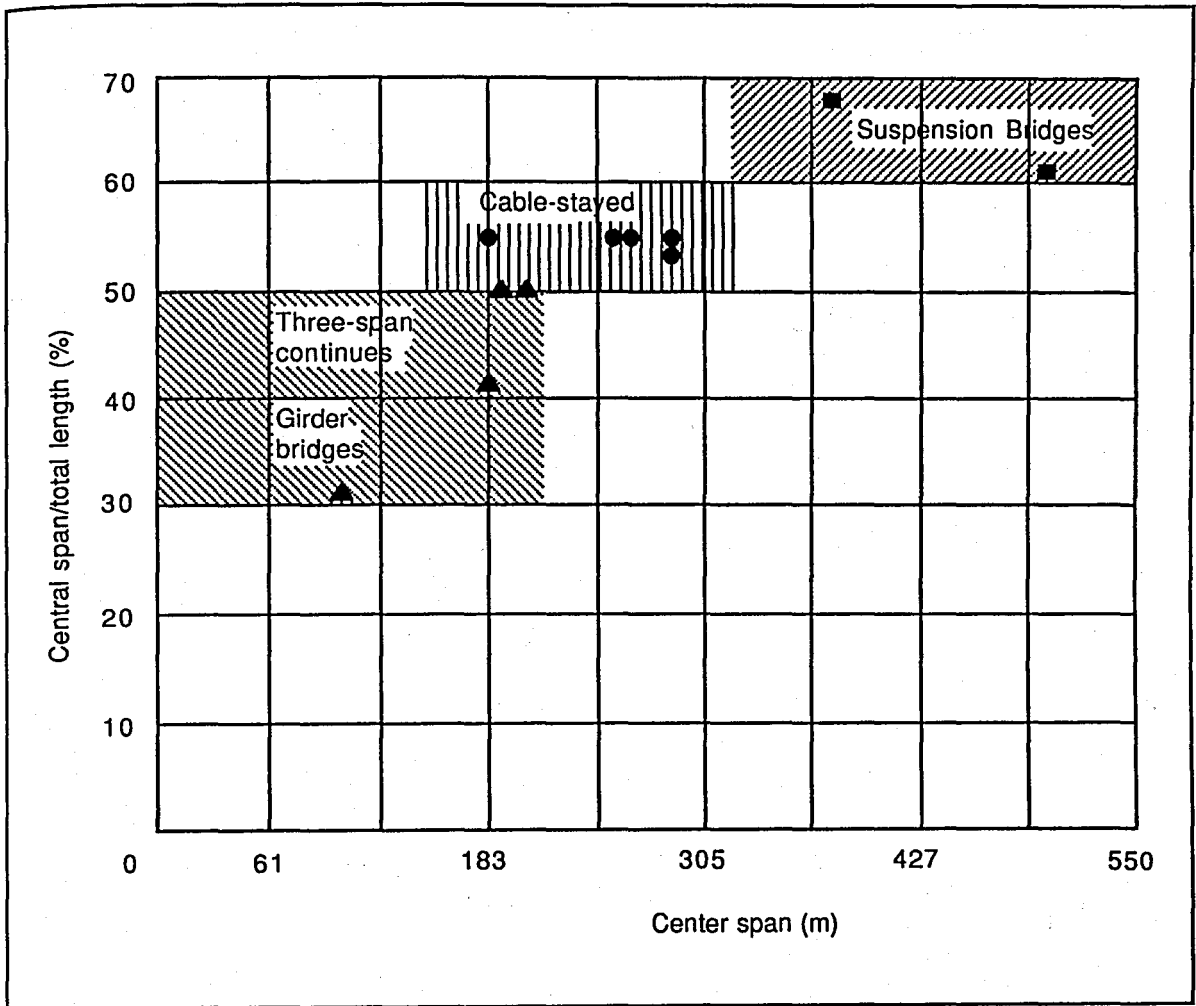

FIGURE 6.1. BRIDGE TYPE SPAN COMPARISON

bridges fall into two distinct paths and may be the result of the different methods of design and different arrangements of the cross-sectional girders. Taylor recognized the difference in the ratio of material to labor costs in Europe and North America and concluded that for Canadian highways cable-stayed bridges with center spans ranging from 210 to 245 meters were 5 to 10 per cent more economical than other types of comparable bridges.

Limited experience to date has indicated that cable-stayed bridges with center spans less than 150 meters are most suitable for pedestrian bridges. The total economical range of the various types of cable-stayed highway and pedestrian bridges have not been fully examined. Therefore, it is incumbent upon designers and contractors to develop the necessary data by careful study and evaluation of each new application as it presents itself. The general economy appears to be present but, for the moment, it must be evaluated separately for each individual application.

The economic survey by Taylor, *Figure 6.2*, has a reference point for a cable-stayed bridge that is higher than one would expect for the magnitude of center span. It appears that this singular point is apparently based on the data taken from the Kniebrücke Bridge at Düsseldorf which is an asymmetrical bridge with one tower as shown in *Figure 6.3*. The data in *Figure 6.2* is for a center span of 320 meters with a corresponding weight of deck structural steel of 0.561 tons per square meters.

If the Kniebrücke Bridge were considered to be one half of a symmetrical two-tower arrangement, with a center span of approximately 610 meters, and the data replotted against previous data, *Figure 6.4*, a different conclusion may be drawn. The cable-stayed bridge is then seen to compete favorably with the suspension bridge of comparable center span. From this limited study it appears reasonable to assume optimistically that cable-stayed bridges may penetrate the complete range of spans now dominated by suspension bridges. In fact, feasibility of a cable-stayed bridge with a center span of approximately 610 meters is being considered in some preliminary bridge designs. Improved and imaginative methods of construction may tip the economic scale in favor of the cable-stayed bridge.

When Thul wrote : "It is considered highly unlikely or unrealistic to build bridges with very long spans using cable-stayed construction. Such span lengths will be reserved for suspension bridges because there are considerable difficulties in construction of cable-stayed bridges," he apparently did not foresee the effects of improved technology and modern techniques of erection and construction, as perceived by Leonhardt [6]. Leonhardt concluded that cable-stayed bridges are particularly suited for spans in excess of 610 meters and may even be constructed with spans of more than 1520 meters.

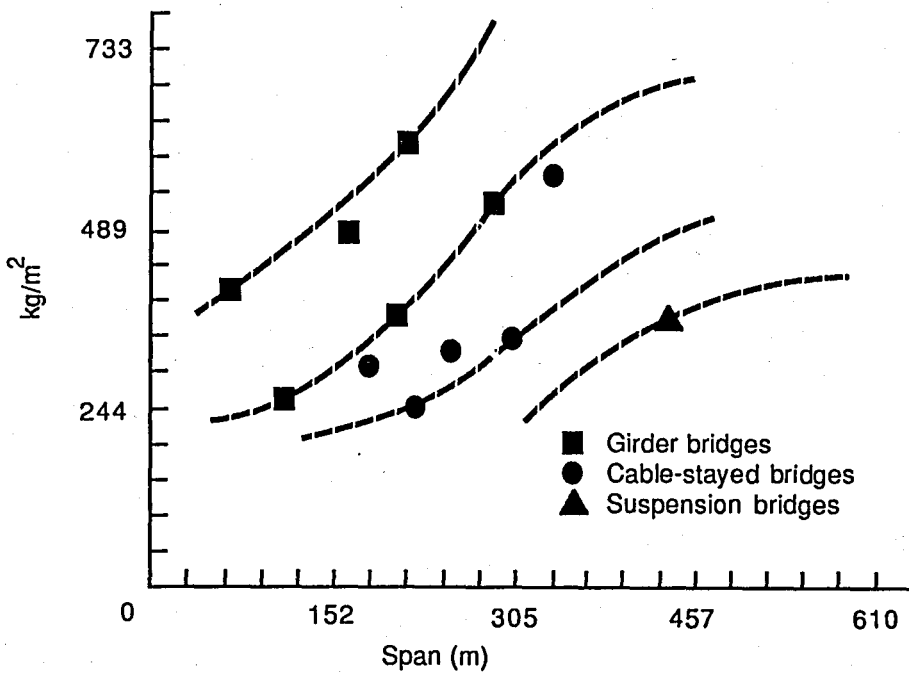

FIGURE 6.2. WEIGHT OF STRUCTURAL STEEL FOR ORTOHOTROPIC STEEL BRIDGES

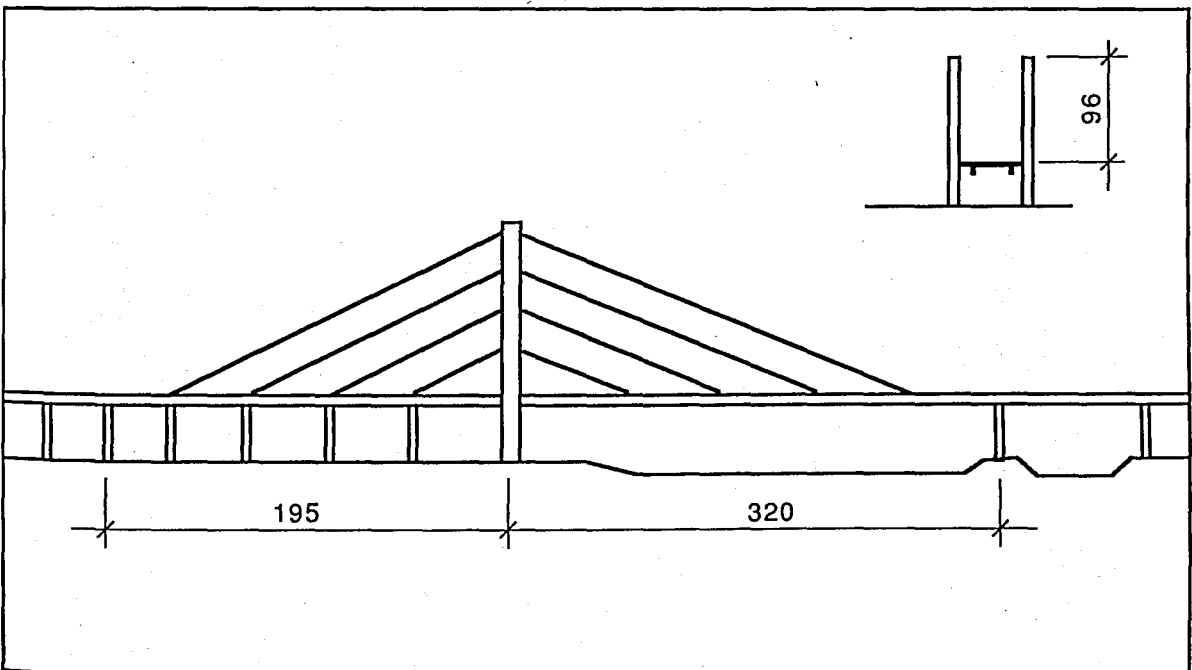

FIGURE 6.3. KNIEBRÜCKE BRIDGE, GERMANY (in meters)

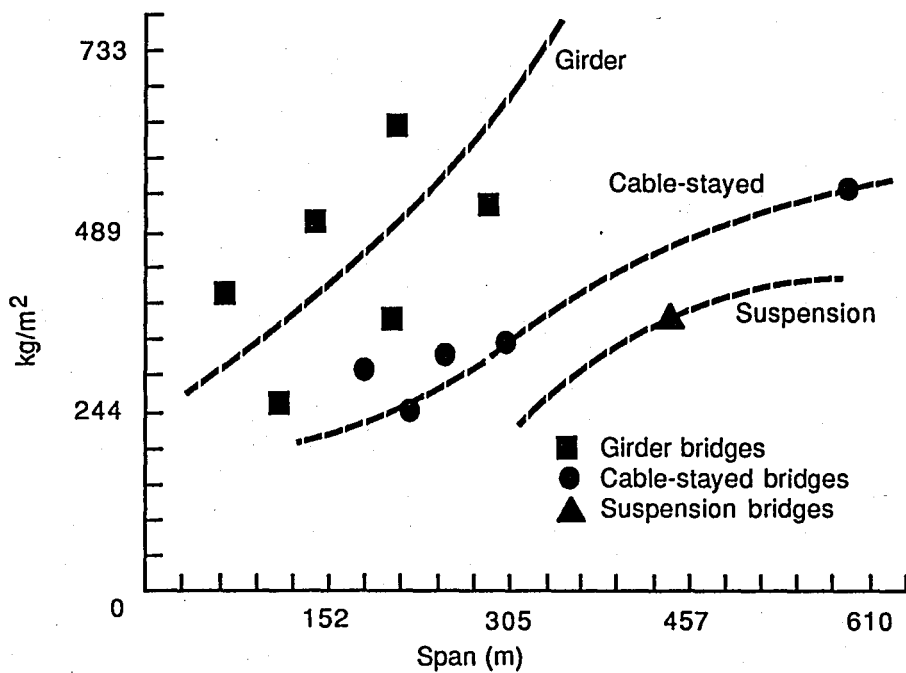

FIGURE 6.4. WEIGHT OF STRUCTURAL STEEL FOR ORTHOTROPIC STEEL BRIDGES

Dubrova has presented some interesting data on the economics of nine types of bridge construction in the Soviet Union [6]. Dubrova evaluated five concrete and four steel bridges. The concrete bridges are cable-stayed, arch-cantilever, arch, rigid frame suspension, and continues. The continues type consists of box-girder construction erected by the cantilever method. The arch-cantilever is constructed as a cantilever for dead load and pin-connected at midspan for live load shear transfer without moment resistance. When moment capability is built into midspan connection, the structure reacts as an arch for live loads. The rigid frame suspension bridge is constructed as a cantilever with a drop-in suspended center section. The steel bridges are cable-stayed, conventional suspension, arch, and a continues type.

Although the relative costs of construction in the Soviet Union differ from the costs in the United States, the economic study by Dubrova is useful in developing a comparative relationship of the relative costs of the various types of bridges.

Dubrova's economic evaluation included the costs of piers and the erection procedures combined with the cost of the superstructure. The study of the costs of different erection methods, illustrated in *Figure 6.5*, indicates a variation of 300 per cent between the cantilever and pontoon assemblies. The plot indicates a decided advantage for the cantilever method of construction.

Another study was concerned with the amount of concrete used in the superstructure as a function of the span length. A graphical representation shown in *Figure 6.6* indicates the volume of concrete per square meter of bridge deck plotted against the span length of the bridge.

For the span length investigated, ranging from 61 to 305 meters, the cable-stayed bridge required the least volume of concrete. The other types of bridges in order of least concrete usage are arch-cantilever, arch, rigid frame suspension, and continues. The variation in concrete volume required for the various bridge types indicates a big difference between the lightest cable-stayed system and the continues system, especially as the span lengths increase beyond 245 meters.

An investigation of similar bridge types using a structural steel superstructure is illustrated in *Figure 6.7*. The plot indicates the amount of steel in kilograms per square meter of bridge surface versus span lengths ranging from 61 to 550 meters. As in the previous study of concrete usage, the cable-stayed system is the most economical in the span range of 183 to 305 meters, and the conventional system becomes the most economical beyond the 305 - meter span length. The other types follows a similar ranking order with respect to concrete usage, *Figure 6.6*.

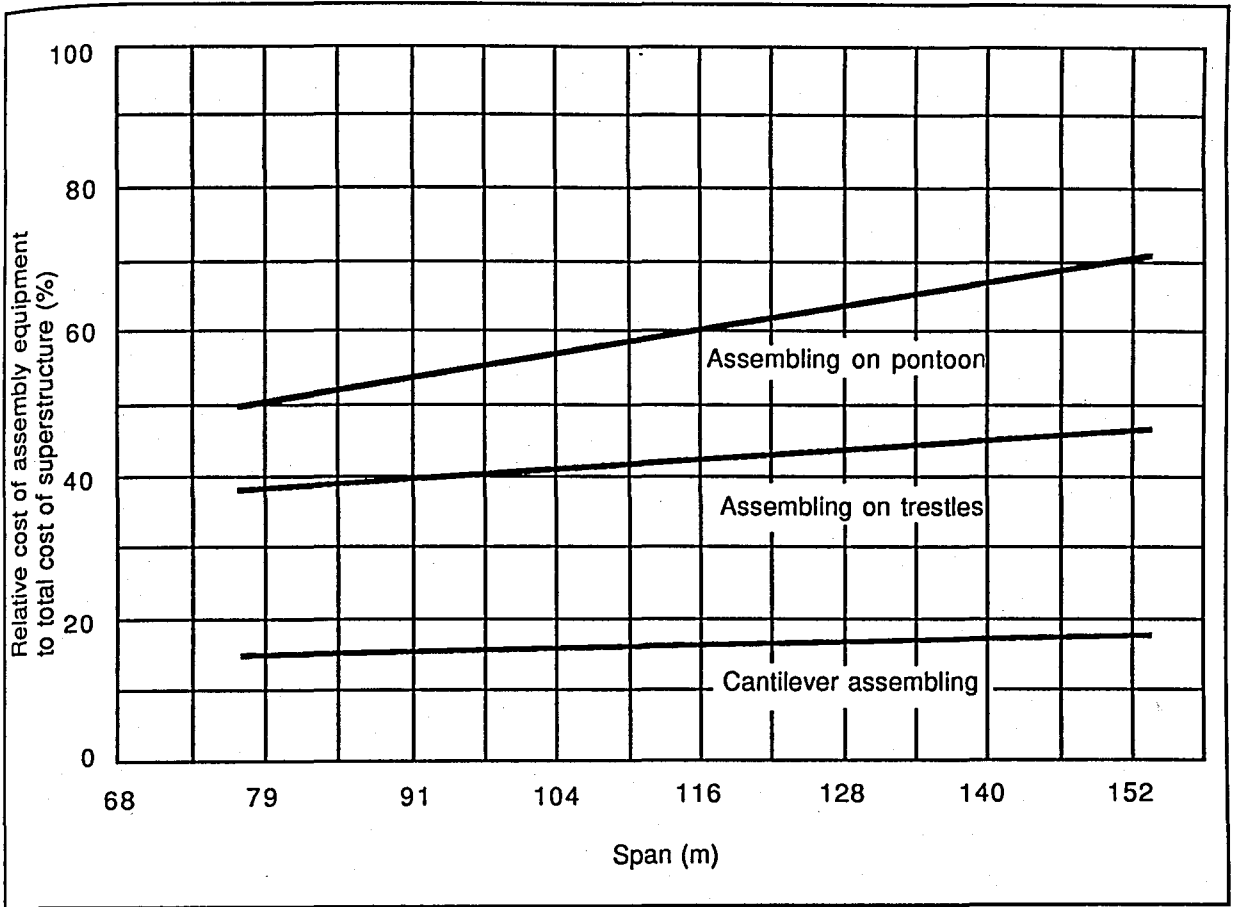

**FIGURE 6.5. RELATION OF ASSEMBLY EQUIPMENT AND TOTAL COST TO SPAN OF BRIDGE**

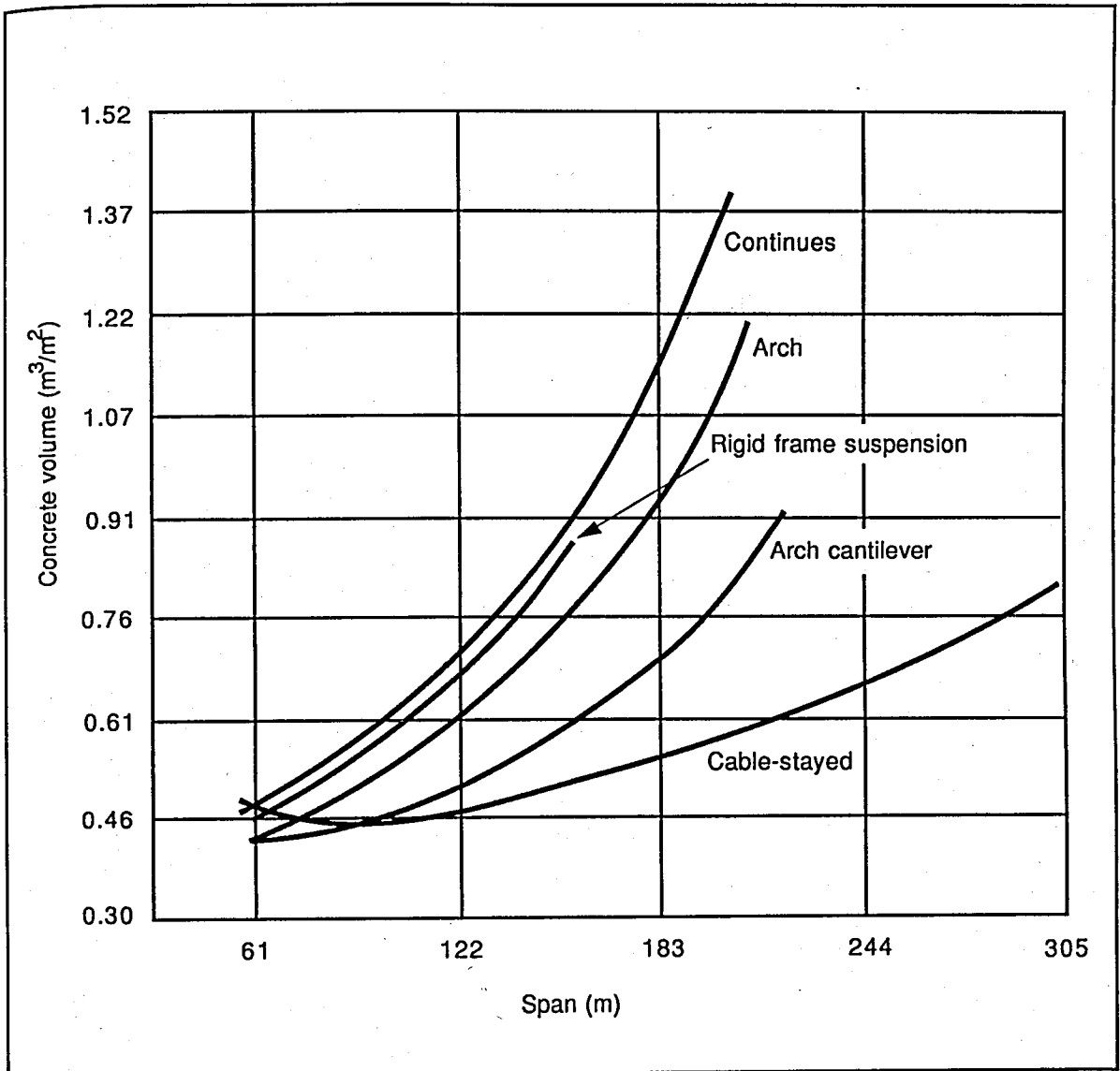

FIGURE 6.6. CONCRETE SUPERSTRUCTURE VOLUME VERSUS SPAN OF BRIDGE

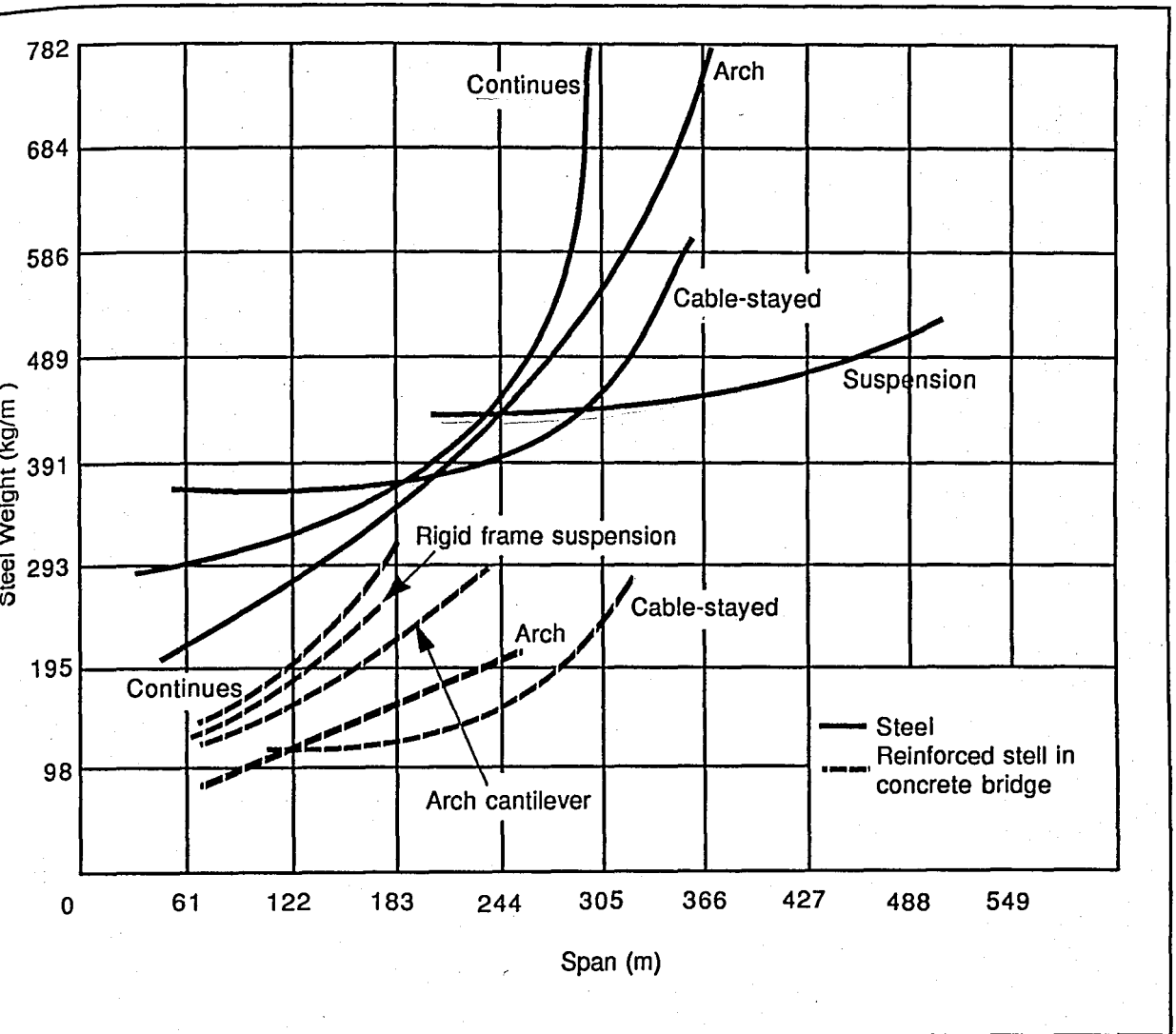

FIGURE 6.7. STEEL SUPERSTRUCTURE WEIGHT VERSUS SPAN OF BRIDGE

The data based on the current costs of design and construction appear to reinforce the concept that suspension bridges are the most economical for the longer spans. However, Leonhardt indicated that cable-stayed bridges can be directly competitive with the classical suspension bridge when innovative methods of design and construction are considered. *Figure 6.7* also indicates the amount of reinforcing steel used in the five bridges plotted in *Figure 6.6*. The steel weight relationships follow very closely the concrete relationships with the exception of the interchange of the arch and arch-cantilever bridges.

A separate study of the amount of concrete required for the piers of various types of bridges is illustrated in *Figure 6.8*. The plot indicates a volume of pier concrete in cubic meters per square meter of bridge deck versus span lengths ranging from 46 to 152 meters. The figure is a composite; it includes the bridges with and concrete superstructures. The solid lines are steel structures and dashed lines represent the concrete superstructure.

As evidenced in the previous studies, the cable-stayed and suspension systems are the most economical for both types of superstructures. Furthermore, this study indicates that these systems require less pier volume for the complete range of span lengths. evidently this fact is the result of less total weight for the superstructures.

When Dubrova combined the cost data relationships for the individual components he determined the total cost of the bridge in terms of the unit area of the bridge deck, *Figure 6.9*. As one would expect, the cable stayed and suspension system show up as the most economical types. The cable-stayed system falls in the range of span lengths from 120 to 305 meters and suspension system takes over beyond the 305-meter span.

Dubrova's investigation in terms of current bridge construction practices in the Soviet Union indicates that continues box girders erected by the cantilever method are most economical for the range of spans from 46 to 152 meters. The cable-stayed system with a concrete superstructure is most economical to 245 meters, while the cable-stayed system with a steel superstructure is economical to a span of 305-meters. Beyond the 305-meter span length the classical suspension bridge becomes the most economical type.

However, it is important to bear in mind that these are idealized studies which are made around late 80s assuming current costs and methods in those days and are ever-changing and influence the designs chosen.

Designers and contractors should be alert to constant innovations in bridge design and construction methods. What may appear to be standard practice one day may become obsolete and the next day as a result of imaginative and innovative contractors and designers.

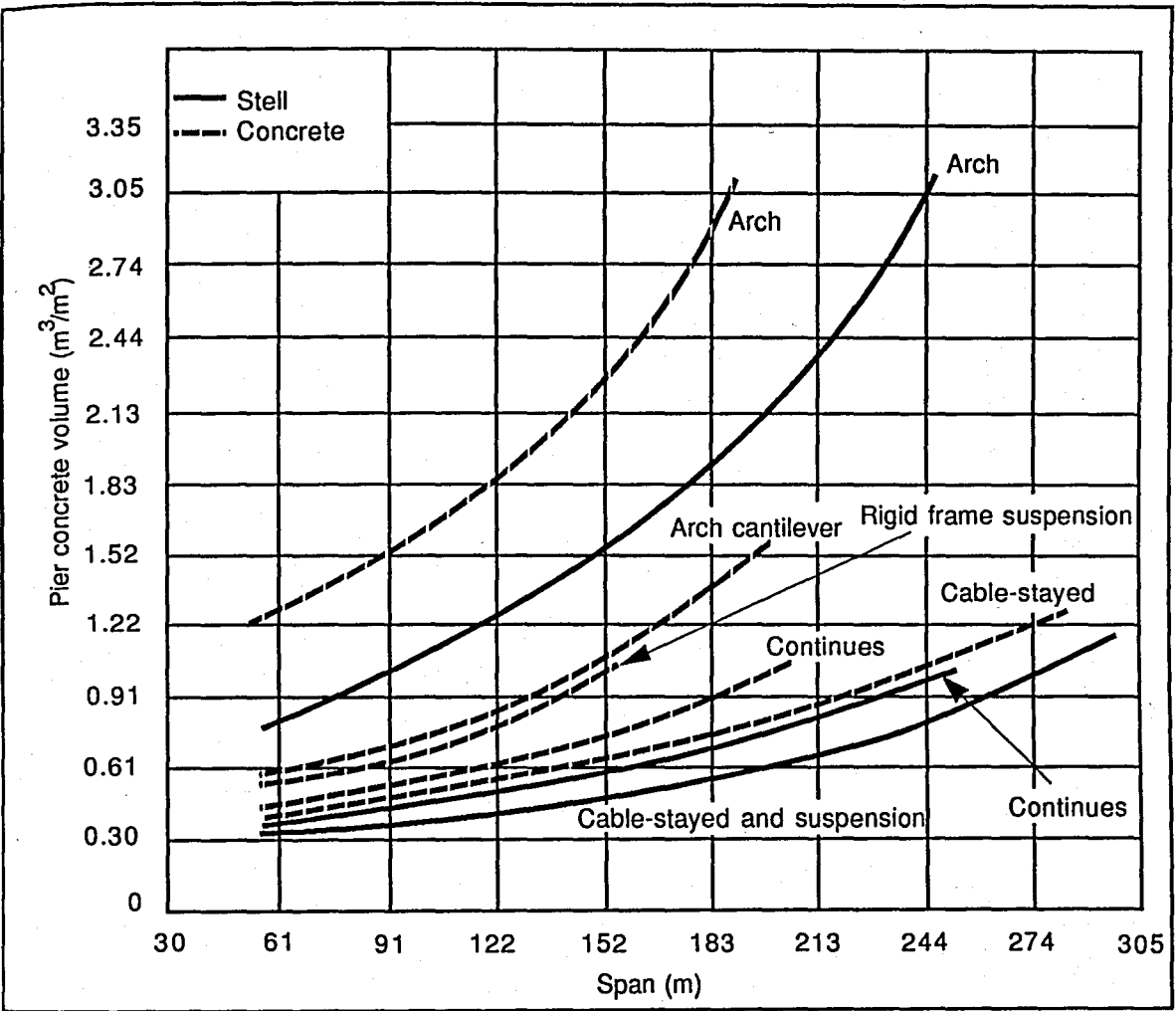

FIGURE 6.8. PIER CONCRETE VOLUME VERSUS SPAN OF BRIDGE

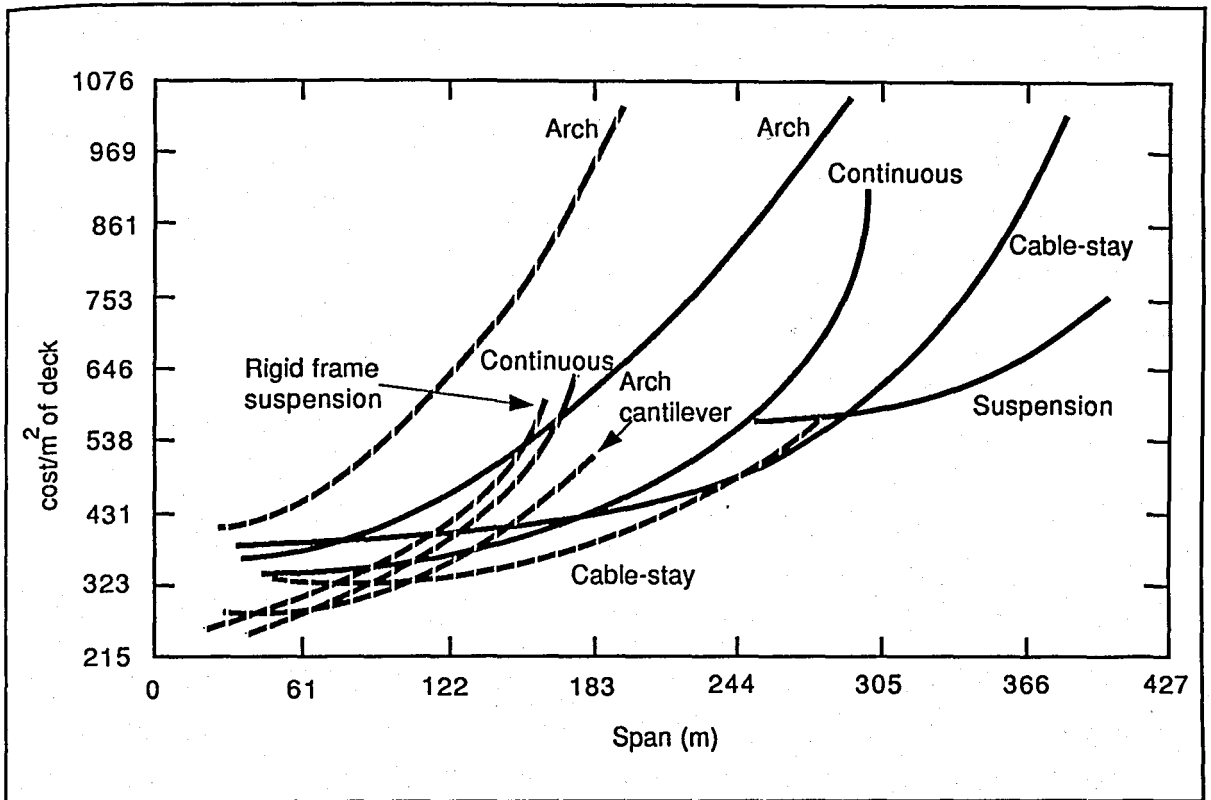

FIGURE 6.9. COST PER  $\text{m}^2$  DECK VERSUS SPAN

### 6.3. Economic Comparisons for Pasco-Kennewick Bridge in the United States

The economic evaluation of this structure considered five alternate structural designs [6]:

1. Constant-depth steel plate girders with a precast composite deck;
2. Cable-stayed girder with a deck constructed a precast concrete;
3. Continues constant-depth posttensioned concrete box girder, constructed on shore and pushed into position;
4. Variable-depth posttensioned concrete box girder constructed segmentally by the cantilever method;
5. Asymmetrical steel box girder cable-stayed main span concrete box-girder approach span.

Studies were based on an approximate overall length of structure of 756 meters, four traffic lanes and two side-walks, and a minimum vertical navigation clearance of 15 meters above the 50-year flood level over a horizontal channel distance of 107 meters. It is to be noted that after a final choice was made some minor changes were made in the design.

The previously mentioned alternates were considered the most feasible and were studied in detail. Other alternates were studied but where then discarded as unfeasible. These included steel orthotropic plate deck girders, cable-stayed steel orthotropic plate girders, and various span configurations of steel plate girders combined with steel or concrete girder approach spans.

A brief description of the five principal as presented by the consultants, Arvid Grant and Associates, Inc., in professional collaboration with Leonhardt and Andra, in their preliminary design report are summarized in the following.

The steel plate girder design, alternate 1, *Figure 6.10 (a)* consisted of eight continues spans with expansion joints only at the abutments. Span arrangement starting at the Pasco abutment was 45-94-100-131-three 100 meters-80 meters for a total length of 750 meters. The superstructure consisted of four lines of girders 6.1 meters on centers with a constant depth of 4.6 meters. Fixed bearings were located at the piers adjacent to the center 131-meters span with all other bearings being expansion bearings. The deck was envisioned as precast units posttensioned longitudinally before being made composite with the deck.

The preliminary design for alternate 2, *Figure 6.10 (b)*, contemplated an overall length of structure of 758 meters. The 548-meters main unit was to be supported by a cable stay configuration radiating from the pylons in two vertical planes. The deck structure was continues from abutment to abutment, with expansion joints only at the abutments.

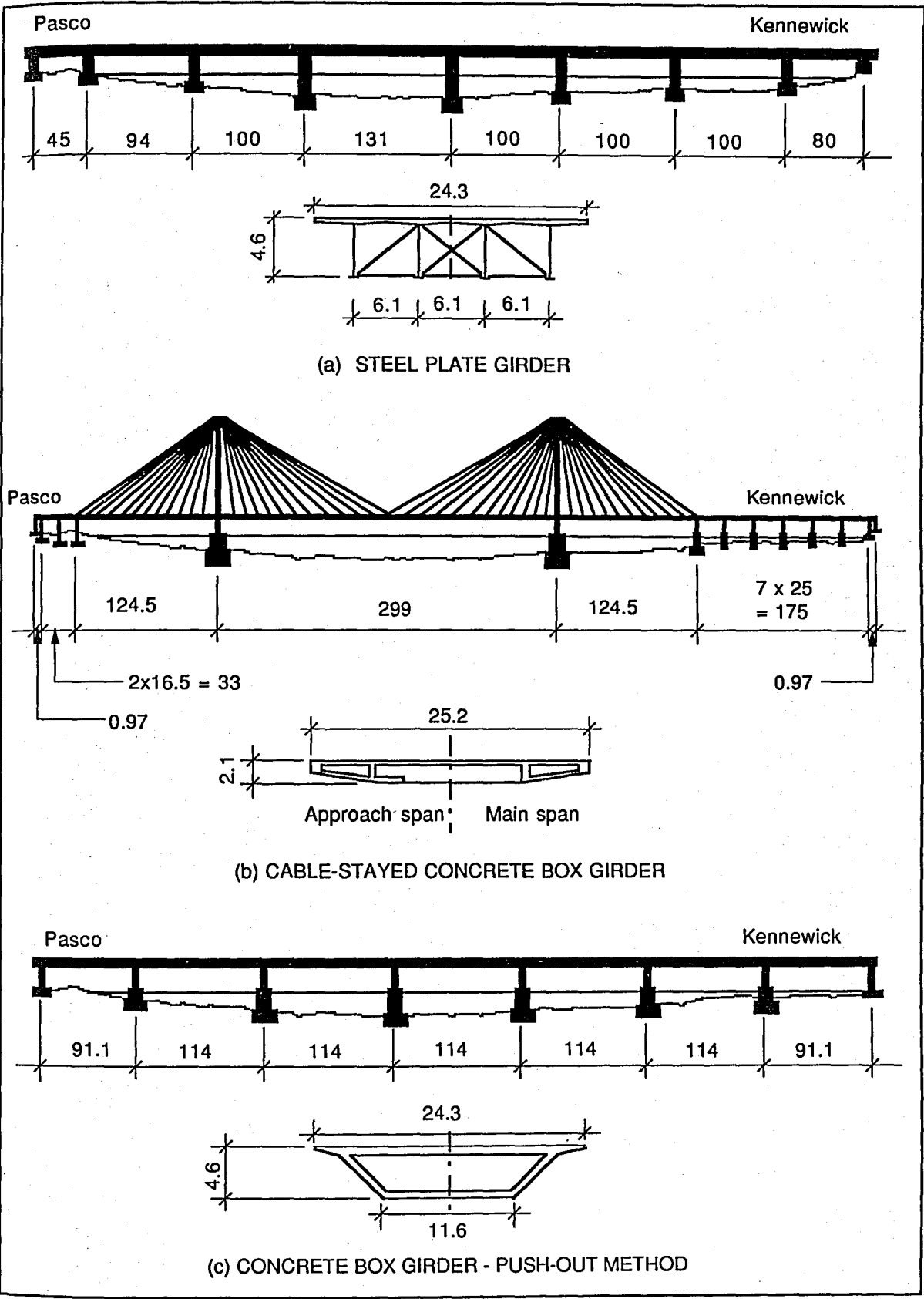

FIGURE 6.10. PRELIMINARY DESIGN ALTERNATIVES FOR PASCO-KENNEWICK BRIDGE (In meters)

Parallel wire strands supported the precast deck every 7.3 meters. The deck was only 2.1 meters deep and consisted of continuous triangular box beams at the edges connected by cross beams at 2.7-meter spacing. The unit was open in the cable-supported portion, (i.e., it had no enclosing bottom flange) and the approach spans were fully closed to partially closed approaching to cable-stay portion. The cross beams were prestressed except in the approach spans where only longitudinal prestressing was required. Main longitudinal webs were prestressed at the middle of the main span and at the ends of the end spans (cable-stayed) where the axial force of the cables was small. Mild steel reinforcement was utilized in both directions.

Alternate 3, *Figure 6.10 (c)*, proposed a single-cell concrete box with five interior spans of 114 meters and end spans of 91.1 meters. The superstructure box had a constant depth of 4.6 meters, an overall width of 24.3 meters, and a bottom flange width of 11.6 meters, with the transverse prestressing in the top flange. Longitudinal prestressing was to be in two stages, first stage for construction and launching was a concentric force of 4400 tons positioned in the webs and flanges, second stage prestressing required 11000 tons installed externally in the box. The superstructure would be constructed in successive 22.9 meter length units at one embankment and progressively pushed out until the opposite abutment was reached. temporary falseworks bents at the center of each span and a launching nose attached to the forward end of the superstructure would be required to reduce cantilever stresses during erection.

Posttensioned balanced cantilever segmental construction, alternate 4, *Figure 6.11 (d)*, consisted of a main span of 152.4 meters, three 76.2-meter side spans on each side, and 71-meter end spans. The main span and two flanking spans were launched and all other spans were of constant depth. Free cantilever construction without falsework was contemplated. The main span and two flanking spans had a depth varying from 3.2 meters to 7 meters; all other spans had a constant depth of 3.2 meters. Posttensioning was provided in the top of the box for cantilever erection stresses and, after closure, continuity tendons would be provided in the bottom of the box. The deck was posttensioned transversely, and diagonal and vertical tendons were required in the web for shear stress.

Design alternate 5, *Figure 6.11 (e)*, consisted of four concrete girder approach spans on the Pasco side, one at 56.4 meters and three at 68.3 meters; a cable-stayed steel box-girder composite concrete deck main span of 230 meters; and four approach spans on the Kennewick side, three at 68.3 meters and one at 62.2 meters. This alternate was an asymmetric structure with a single A-frame pylon, a radiating stay arrangement in elevation, and a single transverse vertical plane located in the median.

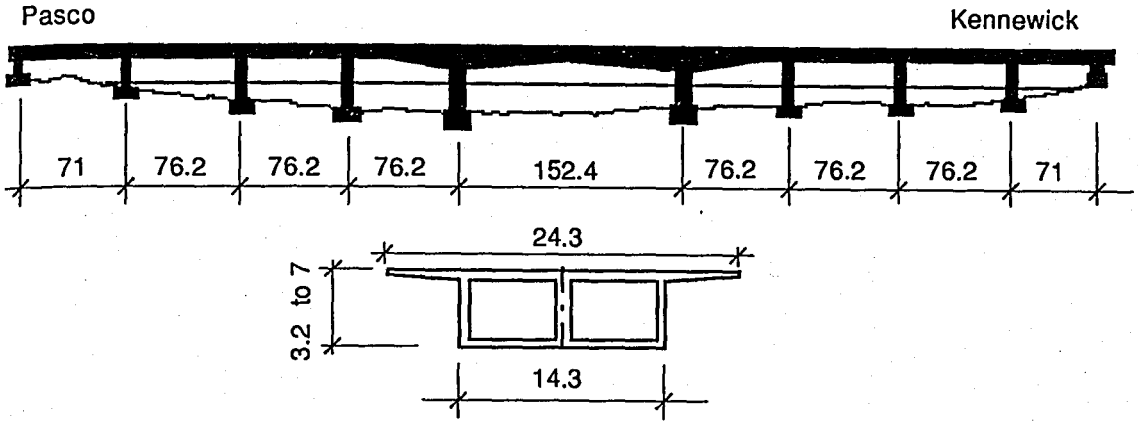

(d) CONCRETE BOX GIRDER - CANTILEVER METHOD

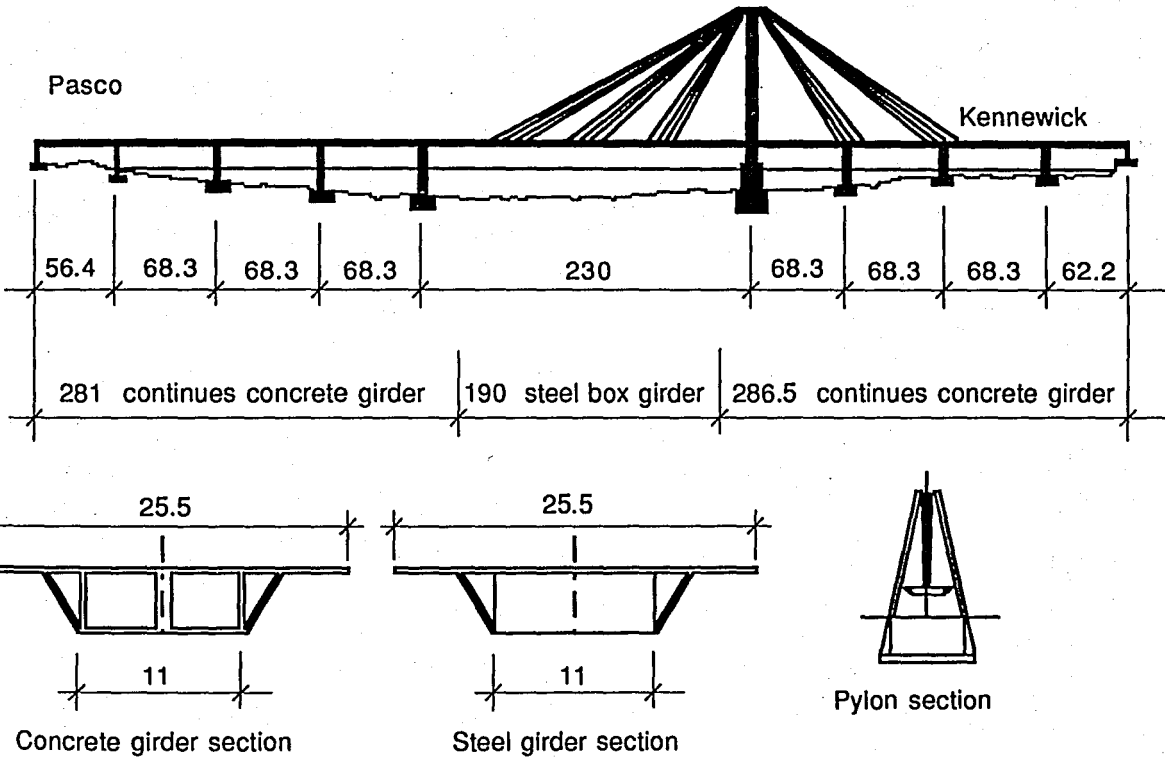

(e) CABLE-STAYED STEEL BOX GIRDER

FIGURE 6.11. PRELIMINARY DESIGN ALTERNATIVES FOR PASCO KENNEWICK BRIDGE ( In meters)

The economic comparison of these five alternatives using alternate 2 (the final design choice) as a base is shown in *Table 6.1*.

As seen from the preceding estimated construction cost comparison (including substructure) there is no conclusive economic argument for the approval of any one design. Therefore, satisfactory functional requirements, anticipating long-term performance, construction and design requirements, as well as the estimated initial costs must also be evaluated.

Functional requirements should consider channel clearance, approach grades, aesthetics, and overload capacity. Long-term performance considerations are maintenance and structure durability. Construction and design requirement considerations include familiarity of construction method, ease of construction, risk during construction. local labor and materials, overall construction time, opportunity for cost reduction in the final design process, and design complexity.

Obviously, considerations of the above items is dependent on the particular site conditions, local environmental conditions relative to natural hazards, along with the local and national economic environment at the time the estimate is made, as well as any short-and-long-term economical conditions that may affect the final cost.

**TABLE 6.1. PASCO-KENNEWICK BRIDGE - ECONOMIC COMPARISON**

| <b>ALTERNATE</b> | <b>DESCRIPTION</b>                      | <b>COST RATIO</b> |
|------------------|---|-------------------|
| 1                | Steel plate girder                      | 1.005             |
| 2                | Cable-stayed concrete box girder        | 1.000             |
| 3                | Concrete box girder - push-out method   | 0.952             |
| 4                | Concrete box girder - Cantilever method | 0.981             |
| 5                | Cable-stayed steel box girder           | 1.019             |

## 7. FLOATING BRIDGES

### 7.1. Introduction

The concept of a floating bridge takes advantage of the natural law of buoyancy of water to support the dead and live loads. There is no need for conventional piers and foundations [7].

A floating bridge is basically a beam on elastic foundation and supports. Vertical loads are resisted by buoyancy. Transverse and longitudinal loads are resisted by a system of anchor cables. Three types of floating bridge models are seen in *Figure 7.1* [8].

Although in most cases bottom anchoring is used as in Third Lake Washington Bridge, the new concept for floating bridges without bottom anchoring has been manifested in the Bergsoy Sound Bridge and the Salhus Bridge in Norway.

A floating bridge may be constructed of wood, steel, concrete or a combination of these, depending on the design requirements. Experience has shown that reinforced and prestressed concrete floating bridges are cost effective.

### 7.2. Environment

Floating bridges are sensitive to environmental loads; i.e. wave height, direction and period, wind speed and direction and tidal vibrations. It is vital in the design of such structures to have accurate predictions of these effects. Therefore a measurement program at the bridge site should be carried out.

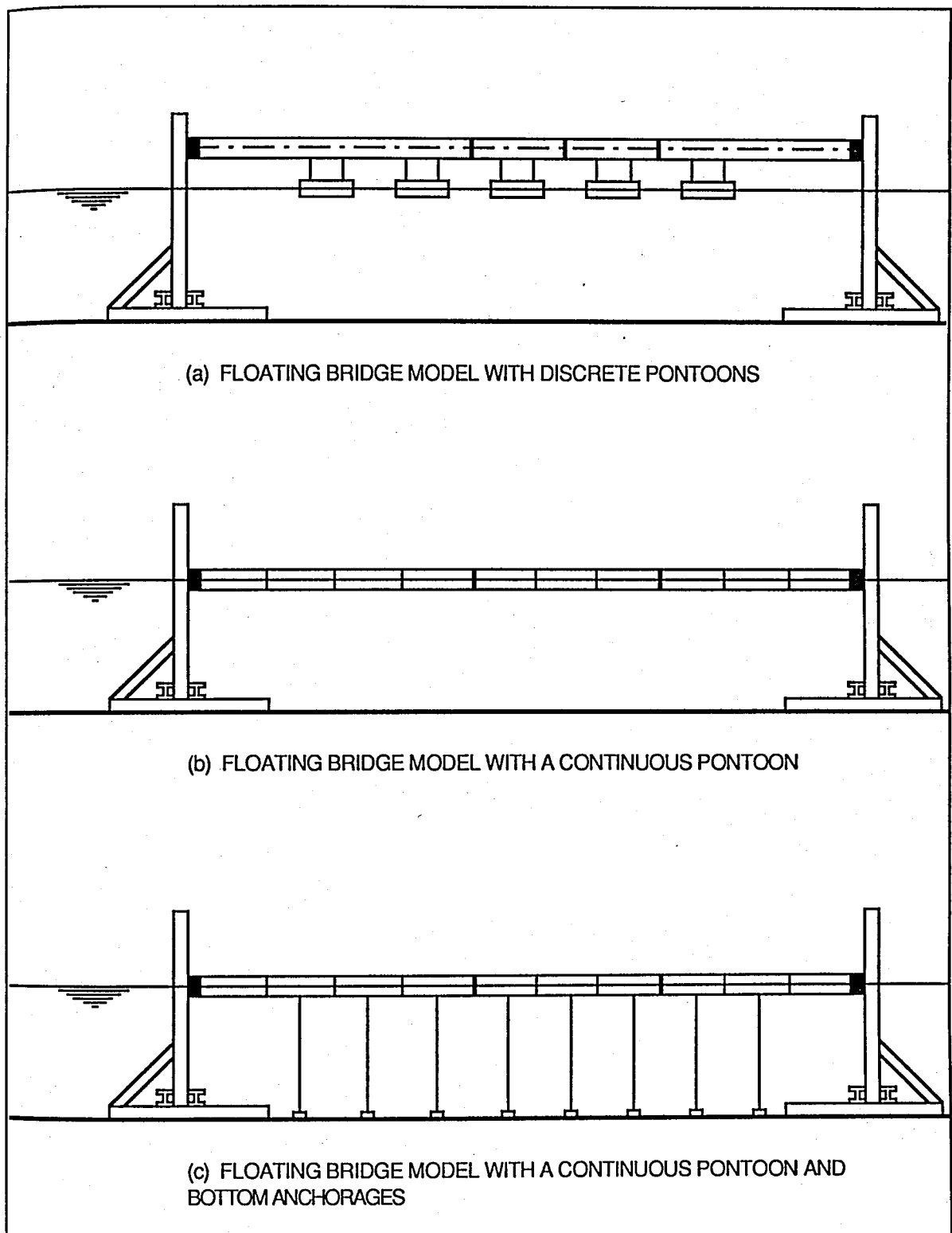

FIGURE 7.1. FLOATING BRIDGE MODELS

Important environmental conditions for the design of floating bridges may be grouped as follows [9]:

- (a) surface waves, current and wind;
- (b) tidal variations;
- (c) density variations in time and space;
- (d) internal waves (stratified flow);
- (e) ice;
- (f) marine growth;
- (g) temperature variations;
- (h) earthquakes;
- (i) wave from landslides.

The wave, current and wind design conditions are derived from statistical treatment of site measurements in relevant locations. In some cases, additional information may also be found from application of hindcasting methods. This means that wind field data are input to numerical simulation models, including the local topography in the area.

The design conditions for wave, current and wind are to be specified for relevant return periods. Further should be provided joint frequency tables for significant wave heights and wave peak periods for long term considerations. This procedure is standard and has been used for offshore structures as well as floating bridges.

### **7.3. Material Technology**

#### **A. Concrete Technology**

A design life time of a 100 years does not exclusively concern the load levels and the structural safety. The durability and the resistance against water penetration is quite as important aspects of the design [9].

Concrete grades of C60-C80 (normal density) is expected utilized in floating bridge design, and the experience from the North sea concrete structures with comparable material qualities is promising.

Based on the experience and recent research/investigations it is considered feasible to produce a concrete material meeting the requirements. Key parameters in this concept are:

- (a) low water, binder ratios (v/c+s). A value of 0.35 may be prescribed;
- (b) use of silica fumes;
- (c) concrete cover of say 50 mm to the reinforcement;

- (d) proper surface treatment of the concrete at an early age;
- (e) limited cracks widths in structural design.

The first two points above will imply a considerable strength of the material, but this not the basic reason for the requirements. The main aim is to obtain a dense concrete, i.e. to obtain suitable permeability properties considering penetration of not only water but also e.g. chlorides.

A good quality of the concrete cover, the surface of the structure, is vital, as this is actually the inlet for the deteriorating process and mechanism. To obtain this, strict and maybe immediately cost-generating precautions seems necessary. Concreting under controlled conditions (sheltered with temperature regulations) and use of membrane and watering of hardening concrete should be anticipated.

## **B. Steel Technology**

The development of high strength steel qualities with excellent properties for welding is giving possibilities for weight and cost reductions for steel structures. theoretically weight reductions of more than 30 per cent is achievable with structures of high strength steel compared to that of the conventional 350 MPa steel [9].

The additional material cost per unit weight for high strength steel have been reduced so the savings from less material to be purchased alone compensate for the higher cost per unit weight for high strength steel have been reduced so the savings from less material to be purchased alone compensate for the higher cost per unit weight. In addition lower weight means less welding (thinner plates), less handling and fabrication, less transportation and less erection cost.

Studies carried out, showed that without performing weight optimization the reductions for ordinary plate girder bridges were found to be typically around 25 per cent. The overall cost reduction was estimated to be from 2 - 9 per cent.

For floating bridges weight reductions will pay off as reduced buoyancy leading to smaller pontoons. smaller pontoons in turn reduce environmental loads from waves and currents. high strength steel seems therefore attractive for this type of bridges. However, the design of floating brides is indeed the art of balancing the design parameters like bridge beam stiffness and bridge masses to achieve the most favourable dynamic behavior. In this respect high strength steel provides the designer with new possibilities for optimal solutions.

## 7.4. Conclusions

Floating bridges are cost effective at wide water crossings compared to conventional bridges as shown in *Figure 7.2 [10]*. A floating bridge is an economical solution but it creates a continuous barrier for navigation, which can be unacceptable in certain cases. To overcome this drawback, elevated spans above the navigation area are a possibility. However, massive pontoons are required to ensure stability and the spans themselves must be long enough to leave adequate space between the pontoons, leading for a costly and sightly structure. More details about floating bridges are given in the Case Studies.

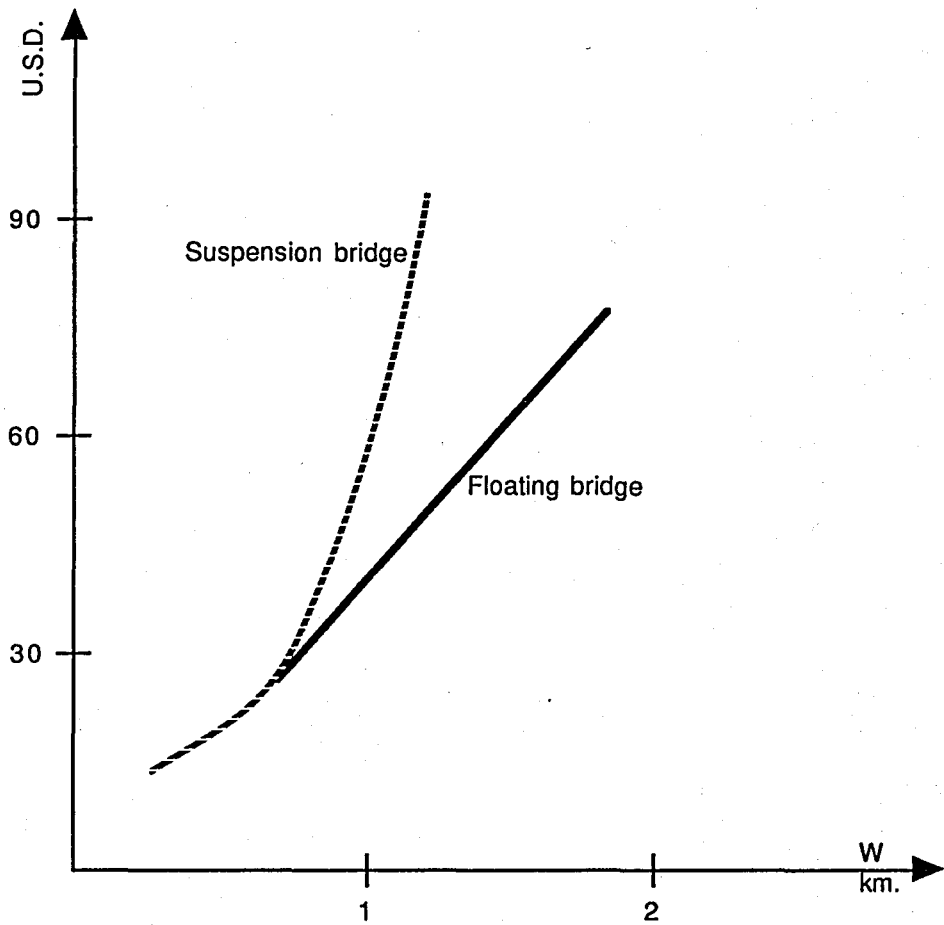

FIGURE 7.2. COST COMPARISON OF TWO ALTERNATIVES

## **8. NEW FEATURES IN BRIDGE DESIGN**

### **8.1. Introduction**

Bridge construction has today achieved a worldwide level of importance that is has never before had in the history of man. Particularly the number and size of bridges has continually increased in the last 100 years. Man's increasing mobility through railway and motorized transport has caused bridges to be built which before had seemed unrealistic.

The most usual way to cross waterways is to build bridges. This solution however is not applicable to very deep and large waterways.

As free span bridges develop to the limit of their technical capabilities, focus has been turned to other concepts to serve the purpose of allowing traffic to cross waters. A number of different concepts are being considered, such as, vertically tethered bridges and submerged floating tube bridges.

### **8.2. Vertically Tethered Bridges**

#### **A. Introduction**

In some areas there are certain similarities between the offshore industry and the bridge building industry. One of these is the wish to keep structures and activity above water. The offshore industry has, since it started, been pushed towards deeper and deeper waters. For these activities, fixed structures at water depths of more than 300 meters have been constructed. Normal water depth may be considered to be in the range 100-200 meters [11].

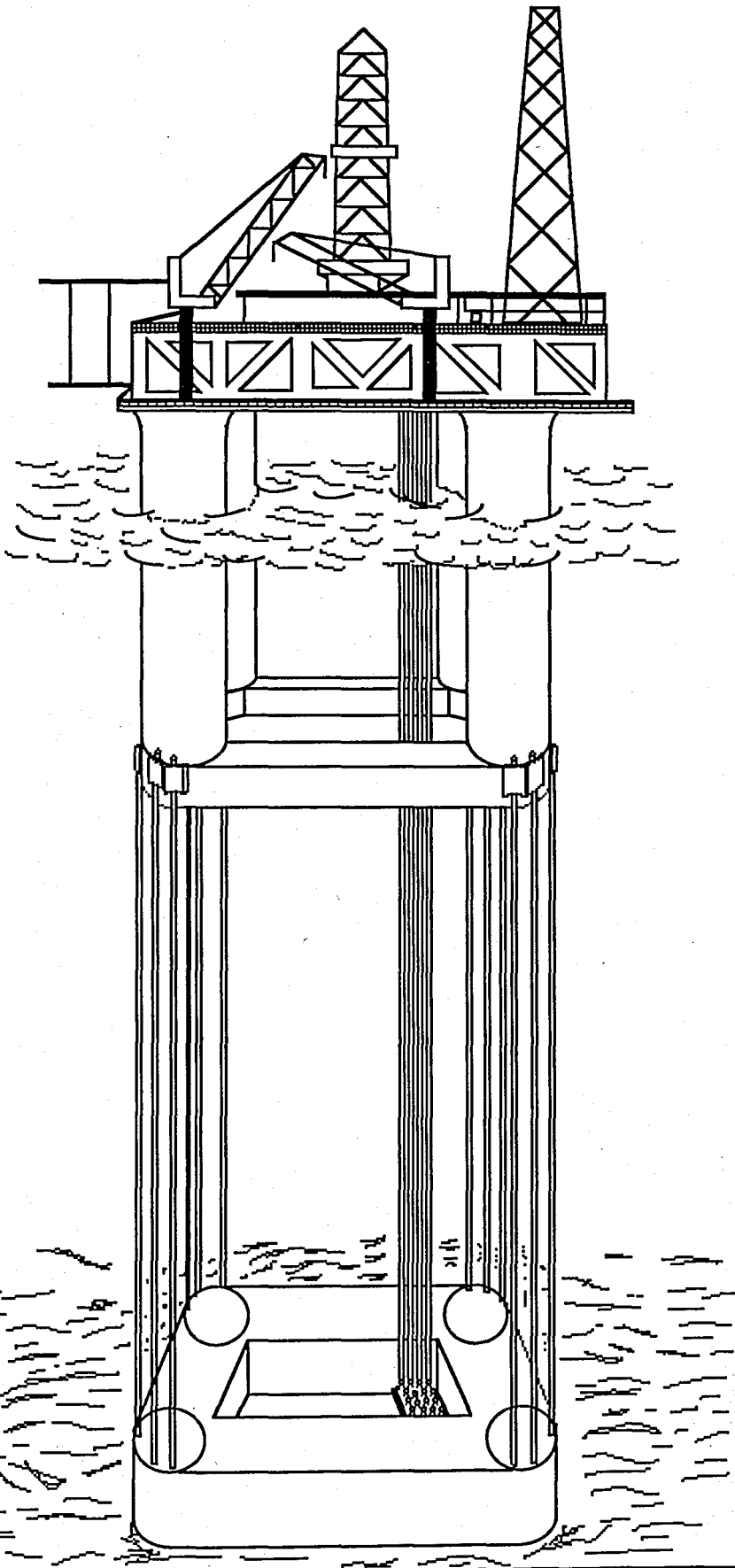

FIGURE 8.1. THE TENSION LEG PLATFORM

In the Gulf of Mexico the offshore industry is developing structures to operate in more than 2000 meters of water. one such structure is the tension leg platform, which is shown in *Figure 8.1*.

This is a compliant floating structure moored to the sea floor using vertical tethers. The buoyancy of the structure is sufficient to hold the 50000 t, above water whilst always keeping positive tension in the tethers. This basic idea has been utilized for the purpose of supporting a long bridge structure.

## **B. Support System**

The support system is principally a buoyant volume with excess buoyancy compared to the weight of the bridge. The excess buoyancy is used to maintain positive tension in the tethers at all times. The tethers are fixed to the seafloor by gravity anchors or tension piles. The bridge therefore has very large vertical stiffness controlled by the axial flexibility of the tethers.

The horizontal stiffness due to the tension in the tethers is very small. This is however, all the horizontal stiffness utilized by a TLP. For a bridge this would require joints in the deck to allow the flexibility. The concept described here utilizes the stiffness in the deck, which is formed as an arc in the horizontal plain, to allow for horizontal reactions. Thus no joints are necessary. *Figure 8.2* shows a drawing of the concept proposed for a Norwegian fjord crossing [11].

## **C. The Bridge Structure**

The bridge structure is formed as a continuous beam in the vertical direction. For cost optimization reasons, one span would be in the range of 250-350 meters. Spans of this range, in combination with methods of construction, favour the steel lattice structure.

To obtain horizontal load capacity the series of straight lattice beam elements form a horizontal arc. The arc forms a very stiff horizontal structure capable of transferring loads, of which wind is dominating, to the land structures.

## **D. The Load Carrying Principles**

The system carries loads in 3 distinct waves.

- (a) The static non variable load of the structure is carried by the buoyancy volumes.
- (b) Vertical load variations such as traffic and change in buoyancy is carried as load variations in the tethers. This also applicable for wave loads. Wave loads have higher frequencies, but are still lower than vertical resonant modes.

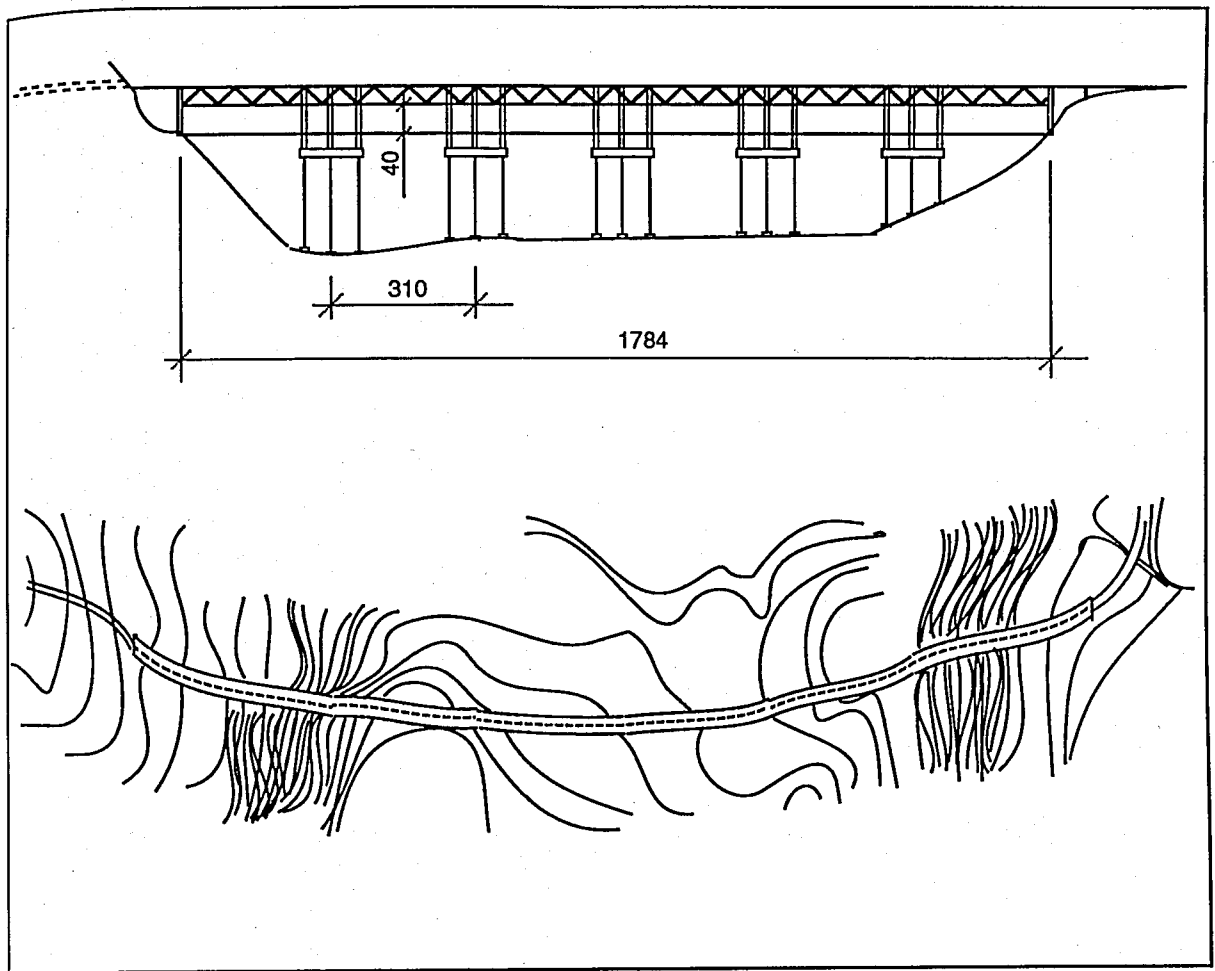

FIGURE 8.2. VERTICALLY TETHERED BRIDGE ( In meters)

(c) Wind load, which is the dominating factor for the horizontal loading, is carried by the arc. As the wind load is acting on the arc itself, only negligible "overturning" moments are encountered.

Current load which is located at the pontoon level, will have a moment arm with respect to the deck. The resulting current load moment is carried through the tethers, while the load itself is transferred to the deck.

For all known floating bridges wave loads and dynamic response is a major concern. In fjord-situations, with wave length in the order of 30-50 meters, the wave load itself may be kept very small. This may be accomplished by keeping the larger volumes of the structure outside the wave action zone. The pontoons are kept below the wave zone and the columns are chosen with relatively small diameter: The columns are thus the only part of the structure which passes through this dynamic zone.

### **E. The Competitive Advantages**

The most obvious advantage of this structure compared to other floating bridges, is the capability to raise the bridge deck structure to an elevated position, thus allowing ship traffic to pass under the bridge.

The use of vertically tethered bridge principles will not restrict the top water layer flow and therefore should be totally acceptable to the environment to the fjord.

### **F. Cost Curve**

The cost-span width relationship for such a structure increases much slower than the same curve for suspension bridges, as shown in *Figure 8.3*. The interaction point between suspension bridges and the vertically tethered bridges seem to be in the range of around 800-900 meters. Beyond which the vertically tethered bridge becomes competitive in price.

### **G. Conclusions**

The concept of the vertically tethered bridge is a development which has the potential of being superior to suspension bridge for spans above 800 meters. In contradiction to conventional floating bridges the concept has the capability of allowing ship traffic to pass under the bridge. The structure is a combination of known elements from the bridge building industry and the offshore industry and thus no further technical developments are required.

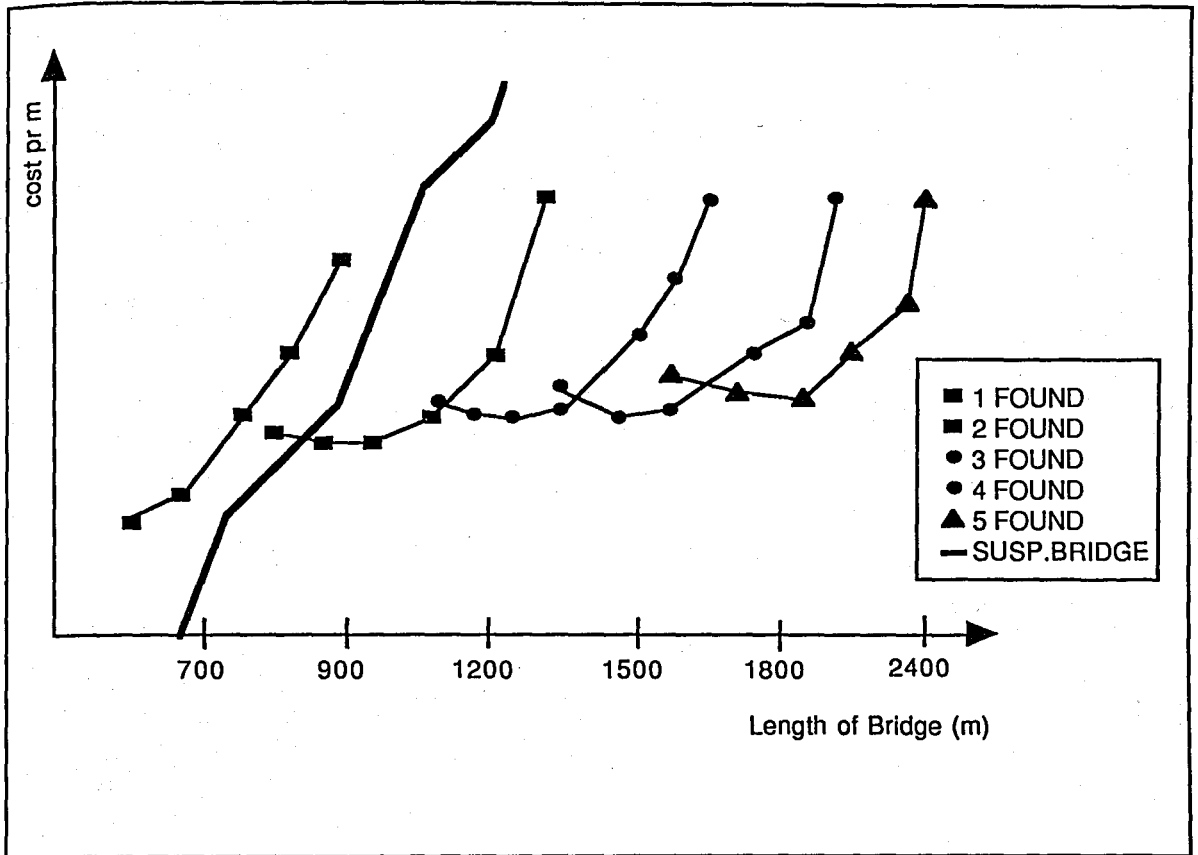

FIGURE 8.3. COST COMPARISON CURVE

## 8.3. Submerged Floating Tube Bridges

### A. Introduction

Submerged floating tube bridges are becoming likely concepts for crossing of long and deep fjords. Considerable design and research work has already been done in Italy and Norway on the crossings of the Messina Strait and Hogsfjorden.

The concepts for submerged floating tubes are typically very long slender structures supported between the end points by tension legs or buoyancy elements in the free surface. Three types of submerged floating tube bridge models are seen in *Figure 8.5 [12]*.

### B. Site Dependent Design Parameters

The reliability of the description of the site conditions is important for the overall safety of tube bridges. The ordinary environmental conditions are determined by site measurements, and a statistical processing of those is performed in order to provide site conditions at certain design probability levels. Accidental conditions from ship grounding, falling objects, etc. are determined from statistics on possible events in the area or other relevant comparable areas world wide. The accuracy in the production of the design site conditions for stochastic variables such as wave conditions and wind is basically determined from the number of events forming the basis for the statistic treatment [9].

#### B.1. Environment

In addition to the loads for floating bridges waves from passing ships are a load factor on submerged floating tube bridges. The variations of the density in time and space are particularly important for a submerged floating tube bridge. Tube bridges are sensitive to density variation since there will be marginal differences between buoyancy and weight. A combination of measurements and numerical models can be used to define design values for density variations. Internal gravity waves are also important for designing of submerged tube bridges.

Internal gravity waves can be generated due to large density gradients between layers of almost constant densities. This is happening in for instance fjords due to variations in temperature and salinity caused by large influx of fresh water. Two types of internal waves due to stratified flow may be created:

- (a) Standing waves: generated by the presence of the bridge itself, causing an increased mean drag force;

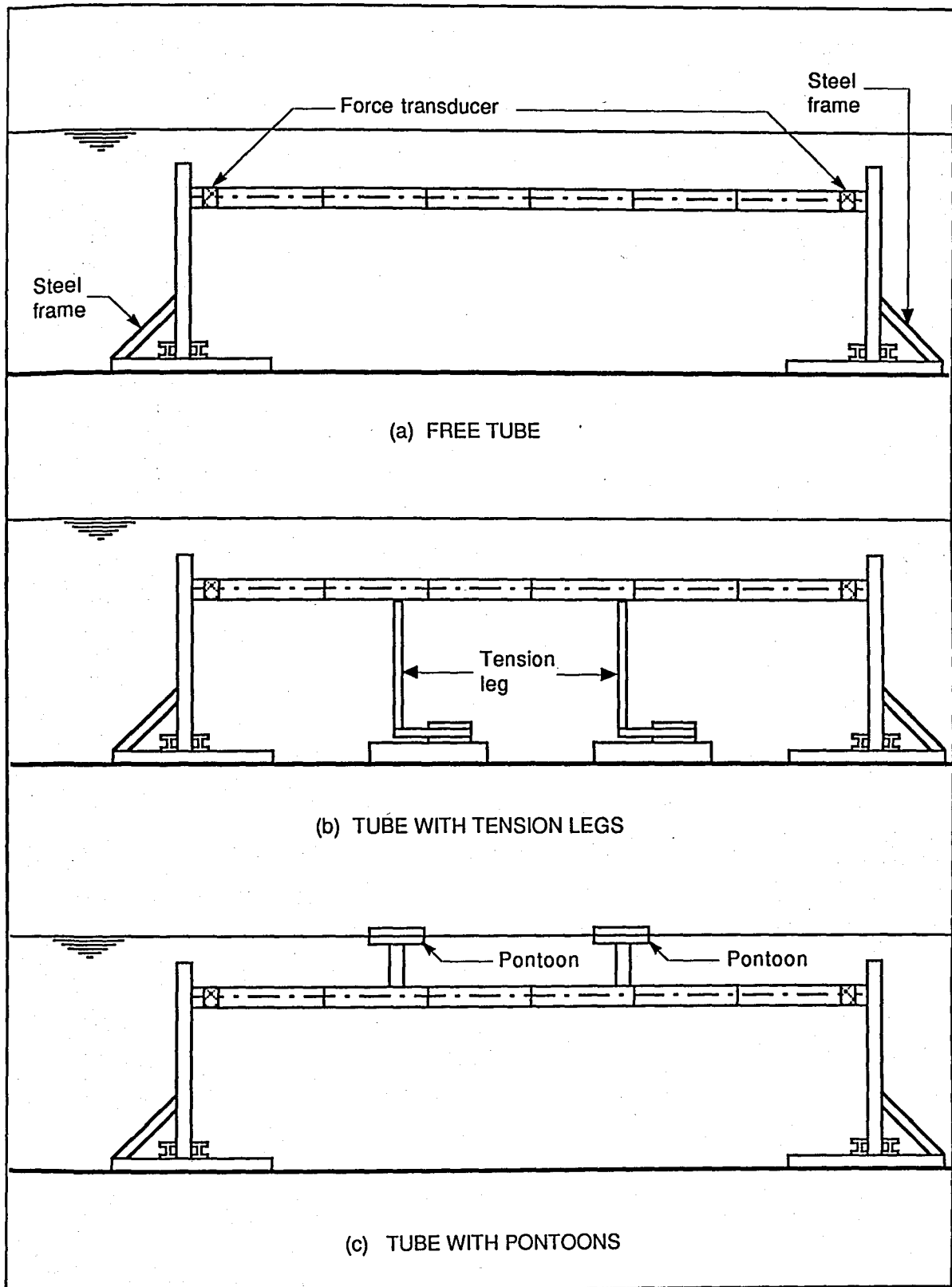

FIGURE 8.5. SUBMERGED FLOATING TUBE BRIDGE MODELS

(b) Progressive waves: generated from instabilities in the jump between layer (or different density) due to effects from wind and/or due to barriers in the fjord.

For design of a tube bridge important parameters for describing internal waves are :

- (a) minimum period;
- (b) largest water particle velocity variation;
- (c) wave length;
- (d) number of internal waves.

## B.2. Accidents

Accidents which are relevant for design of submerged tube bridges may be summarized as:

- (a) impact from cars in the tube;
- (b) impact from ships;
- (c) impact from submarines;
- (d) landslide generated waves;
- (e) fire/explosions;
- (f) falling objects;
- (g) earthquakes;
- (h) abnormal sea state;
- (i) loss of a pontoon or a mooring line.

The probability of occurrence is the main parameter in specifying accidental events for design. Different scenarios using a statistical model have to be considered to determine this parameter. Using for instance the Norwegian Petroleum Directorate (NPD) rules, accidental events which has a yearly probability less than  $10^{-4}$  do not need to be considered in design.

For the possible collision between a ship and a tube bridge two main scenarios for risk analysis may be considered :

- (a) a passing ship (out of control or misnavigated) collides with or slides over the main tube;
- (b) direct collision with a surface pontoon if such is present.

The probability of a collision may be estimated from:

- (a) statistic on vessel traffic;
- (b) exposed area, the area of the bridge;
- (c) active control and safety measures;
- (d) ship size (draft, breadth, length etc.);
- (e) pontoon size and position.

The main outcome from such analysis for further impact load analysis would be:

- (a) probability of accident;
- (b) ship size (dimensions and mass);
- (c) impact velocity.

In defining realistic scenarios for accidental loads common sense is important. Accidents are usually detrimental to the structure and redundancy should be built into the design. For instance it will be required that a tube bridge is designed for loss of a pontoon or failure of a mooring line.

Submerged tube bridges are very sensitive to the wave excitation period. In order to compensate for this an abnormal sea state should be considered with an inherent large margin on the range of wave periods to be considered.

### **C. Special Design Solutions**

As the submerged tube bridge represents a new type of structure new and special design solutions are called for. Here will be mentioned a few areas of concern which relates to the safety as well as the feasibility of a tube bridge concept [9].

One of the proposed construction methods implies construction of the tube in sections. These sections will at a length of say 200 meters be brought to a floating position to be coupled. Special design solutions are then necessary to provide a safe floating operation considering loss of human lives and the structure (floating stability and temporary moorings) . At the same time the solution shall ensure that the construction work will meet the same requirements as set forth for construction work under more controlled conditions as e.g. in a dry dock. The latter should be seen in light of the requirement lifetime of maybe a 100 years, the durability, and the watertightness of the joints. The proposed submerged floating tube bridge concept for Hogsfjorden in Norway is shown in *Figure 8.6*.

Other design solutions reflect the redundancy requirements related to accidents. The bridge is required to withstand loss of a single surface pontoon. Analysis performed with members removed have not indicated problems in meeting these requirements, but the situation underlying the requirement may call for attention: The loss of a pontoon, e.g. caused by a ship collision, may be preceded by rupture of the structural member connecting the pontoon and the main tube of the bridge.

Enforcing such a rupture may imply unacceptable actions on the main tube, and to avoid this, "weak link" solutions has been proposed. Although considered feasible such solutions represent a challenge for design.

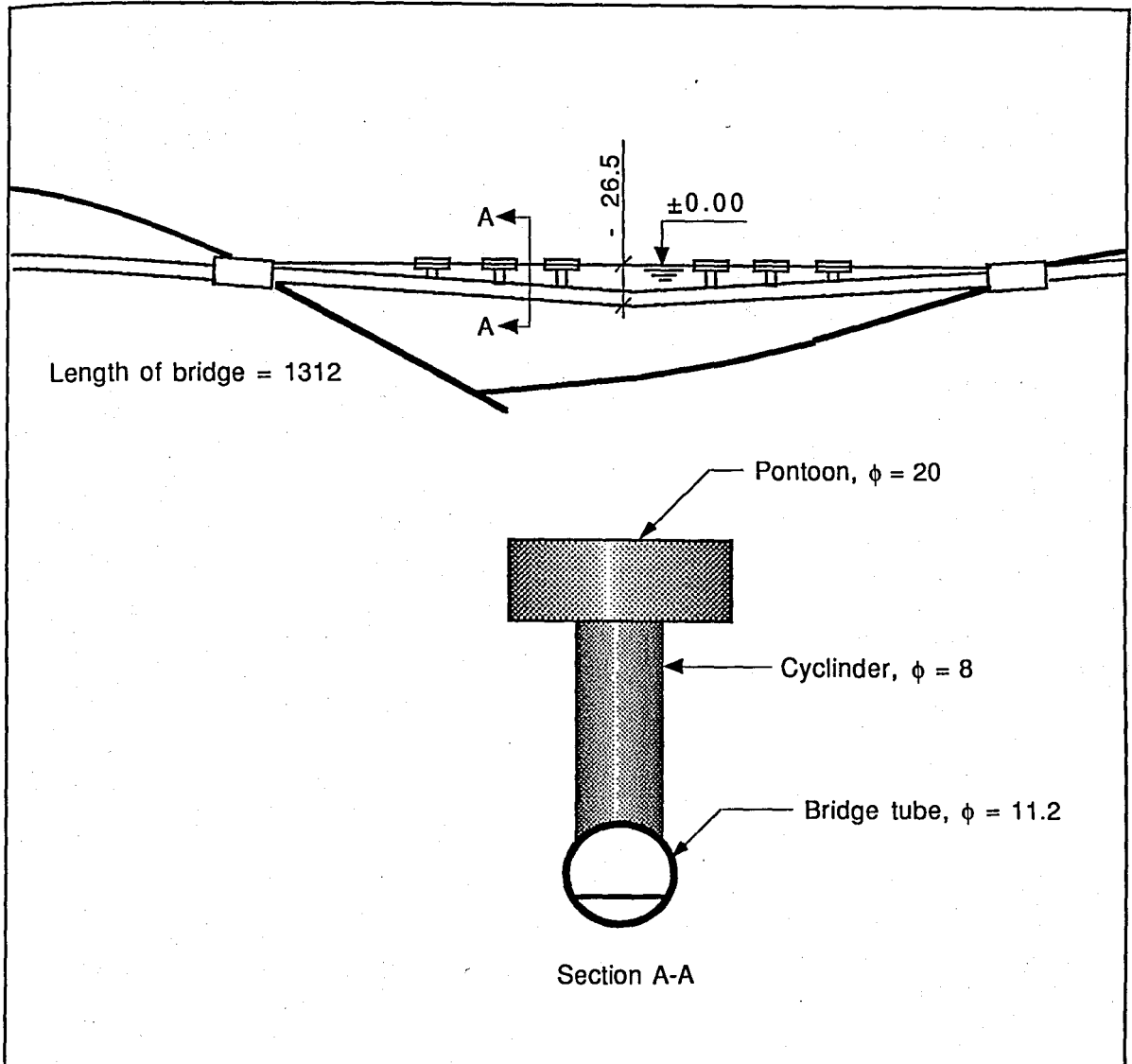

**FIGURE 8.6. POSSIBLE CONCEPT FOR SUBMERGED TUBULAR BRIDGE ACROSS HOGSFJORDEN INNORWAY (In meters)**

## D. Material Technology

The concrete technology described for floating bridges are also valid for submerged floating tube bridges. The steel technology to be used in tube bridge design will benefit on the offshore activity. Both the dimensions of the structure itself and the material thicknesses are comparable to what it is found in offshore structures.

Offshore requirements for materials and the performance and control of welds are likely to be adapted in tube bridge design. Actually, error free welds may be more important in tube bridges than in offshore structures considering leakages, as the latter is typically internally subsectioned.

For life times actual for tube bridges protection against corrosion represents a mentionable cost. Protection methods are known, and a combination of surface treatment and sacrificial anodes will be probably be chosen. An effort should, however, be made to obtain realistic measures for the rate of corrosion and to provide the most cost efficient solution considering the whole life time of the structure [9].

## E. Inspection/Maintenance

The main objective of inspection and maintenance is to maintain the required safety level and to keep the total lifetime operation cost at an optimal level. Submerged tube and tunnel bridges represent high investment cost, construction risk level and structural complexity which is comparable to offshore installations in the North Sea. High attention on a systematic inspection and maintenance level is therefore necessary.

A mean of reducing the total maintenance cost is establishment of a detailed inspection and maintenance scheme. Main elements in such a scheme are:

- (a) easy accessible and relevant data from design, fabrication and installation phases, especially any deviations from specifications are to be recorded;
- (b) updated analysis models of the most important parts of the construction;
- (c) grading of the significance of the various parts of the structure with respect to fatigue, static overloading, failure consequence, corrosion and deterioration;
- (d) long term inspection program with identification of inspection areas, inspection methods, reporting procedures etc.;
- (e) procedures for condition evaluation and action plan in case of damages.

The most important area for inspection of submerged tube and tunnel bridges are

- (a) support or anchor system;
- (b) landing arrangement;
- (c) main tube with respect to damages and leakages.

Inspection methods to be adopted should be carefully selected based on type of defects to look for. In most cases a general visual inspection by an experienced and qualified engineer is sufficient. It is of great importance that the inspector has a good knowledge and understanding the structural and functional behavior.

For a steel concept Non Destructive Testing (NDT) is normally needed in few and highly important areas. The most relevant methods and ultrasonic and magnetic particle testing. Due to cost the areas subject for NDT should be limited to an absolute necessary minimum.

For concrete concepts the use of a newly developed method based on fiberoptics for crack detection is considered.

## **F. Instrumentation**

The importance of the planning and operation of instrumentation systems on a tube bridge should not be underestimated. Instrumentation for traffic regulation and similar purposes are , although important, not dealt with here.

In a pilot project, as the tube bridge project will be, the "structural" instrumentation will serve more needs:

- (a) surveyance;
- (b) design verification;
- (c) experience feed back, technology development.

The term "structural" instrumentation is used to designate instrumentation for structural response such as movements, accelerations, environmental parameters and material degradation.

For a proper operation and maintenance of the structure a surveyance system is needed. further monitoring of environmental conditions and the corresponding structural response will allow for verification of the structural design. Such a verification is desirable as the design of a tube bridge represents an extrapolation of known technology. In this sense, the monitoring will serve as a contribution to the overall effort in providing a safe structure.

Through the verification of the structural design the monitoring serves as feed back on design principles, which will improve our ability to develop the design basis for future tube bridges and familiar structures.

## 9. SHIP COLLISION WITH BRIDGES

### 9.1. Introduction

Any structure established in navigable waters constitutes a hazard to shipping and is itself vulnerable to damage or destruction in the event of vessel collision. Among the most significant structures exposed to this hazard are bridges crossing coastal or inland waterways.

A list of serious accidents recorded during the period 1960-1991 has been included in *Appendix 3*. The records indicate an average of one serious vessel/bridge collision accident per year world wide as indicated in *Figure 9.1*. More than 100 persons died in these accidents and large economic losses were incurred directly in repair or replacement costs as well as indirectly in the form of lost transportation service. The photo in *Figure 9.2* to *Figure 9.7* from actual collision accidents illustrate the seriousness of the subject. The accidents shown are all briefly described in *Appendix 3*.

Many factors are involved in the problem of vessel/bridge collision confronting most countries around the world [13]:

- (a) The vessel traffic intensity has increased considerably in number as well as in size of vessels. Since 1960 the worldwide water borne tonnage has increased at an average yearly rate of 4 per cent.
- (b) Vessel impact loads have not been considered in the design of most bridges more than 25 years old.
- (c) Bridges designed today, poorly sited and with inadequate navigation clearance, indicate that the problem is still not fully appreciated.

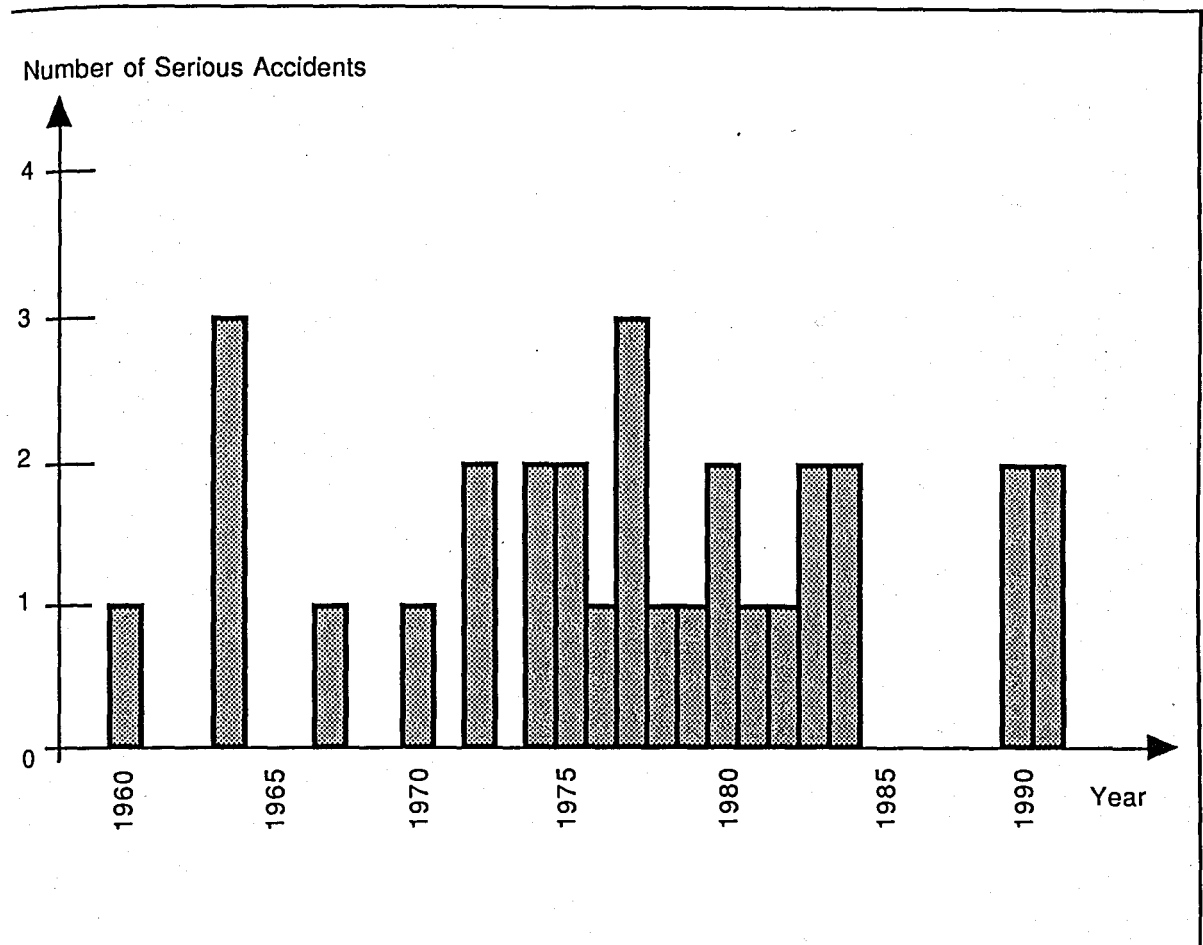

**FIGURE 9.1. THE NUMBER OF SERIOUS VESSEL/BRIDGE COLLISION ACCIDENTS PER YEAR IN THE PERIOD 1960-1991**

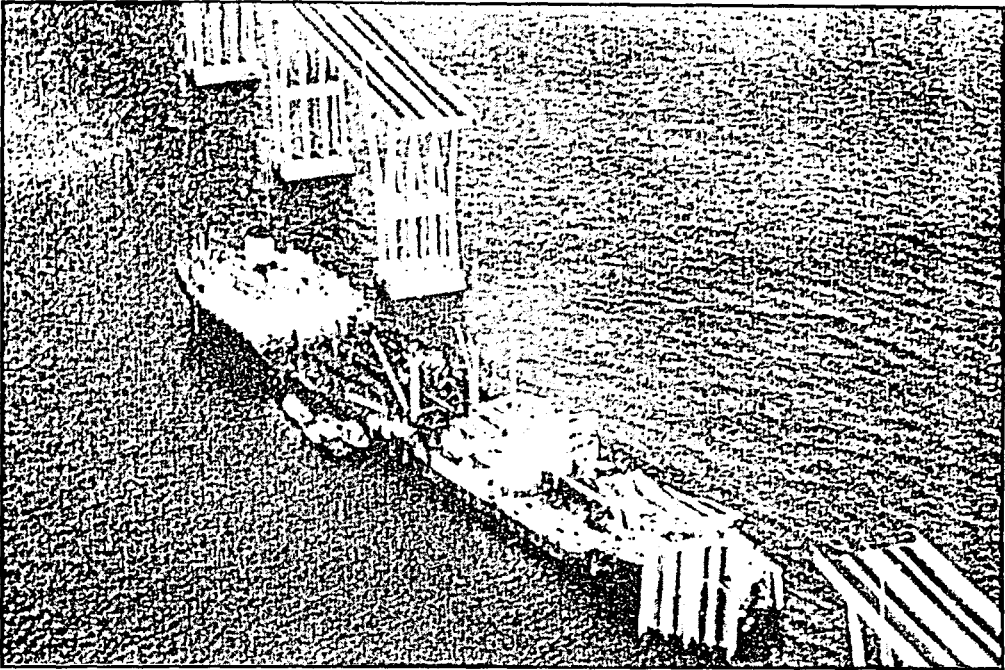

**FIGURE 9.2. THE MARACAIBO BRIDGE ACCIDENT, VENEZUELA, 1964**  
(Courtesy of O. D. Larsen, 1994)

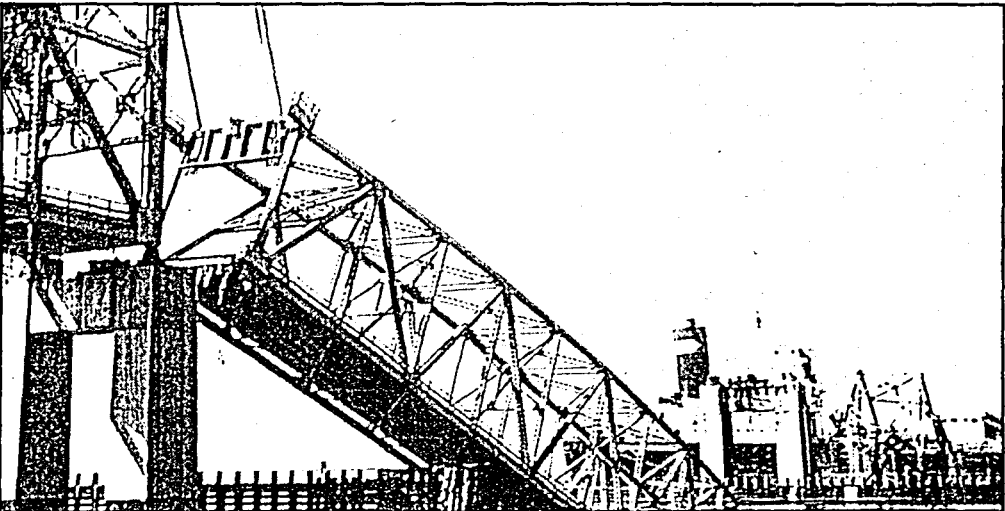

**FIGURE 9.3. THE HOPEWELL BRIDGE ACCIDENT, VIRGINIA, USA, 1977**  
(Courtesy of O. D. Larsen, 1994)

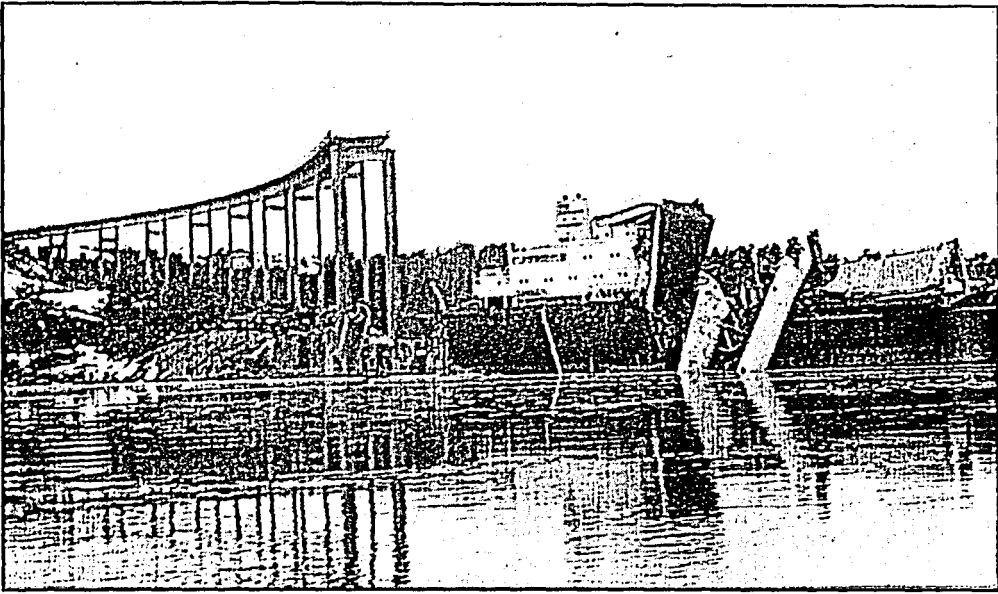

**FIGURE 9.4. THE TJÖRN BRIDGE ACCIDENT, SWEDEN , 1980**  
(Courtesy of O. D. Larsen, 1994)

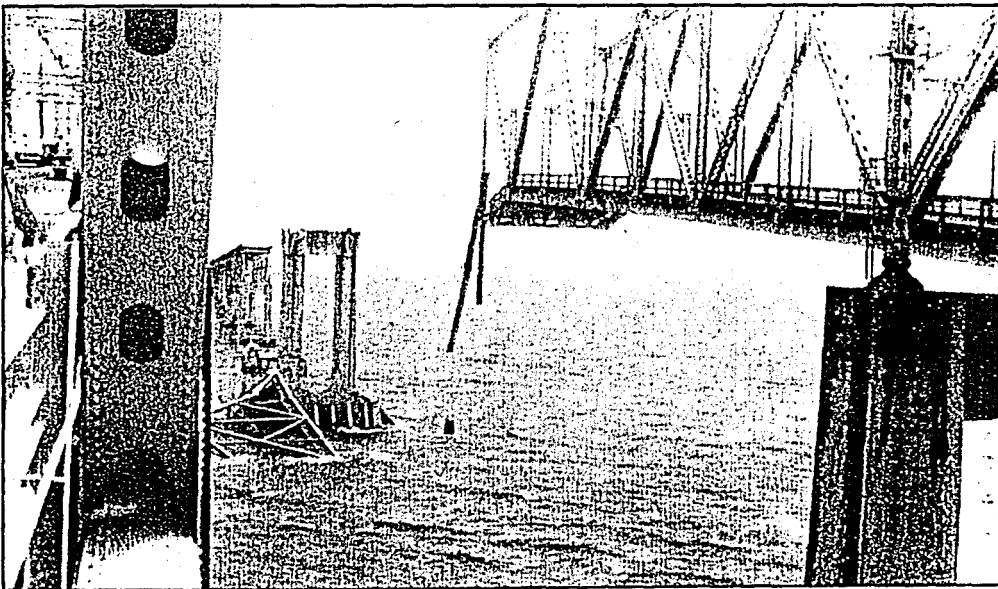

**FIGURE 9.5. THE SUNSHINE SKYWAY BRIDGE ACCIDENT, FLORIDA, USA, 1980**  
(Courtesy of O. D. Larsen, 1994)

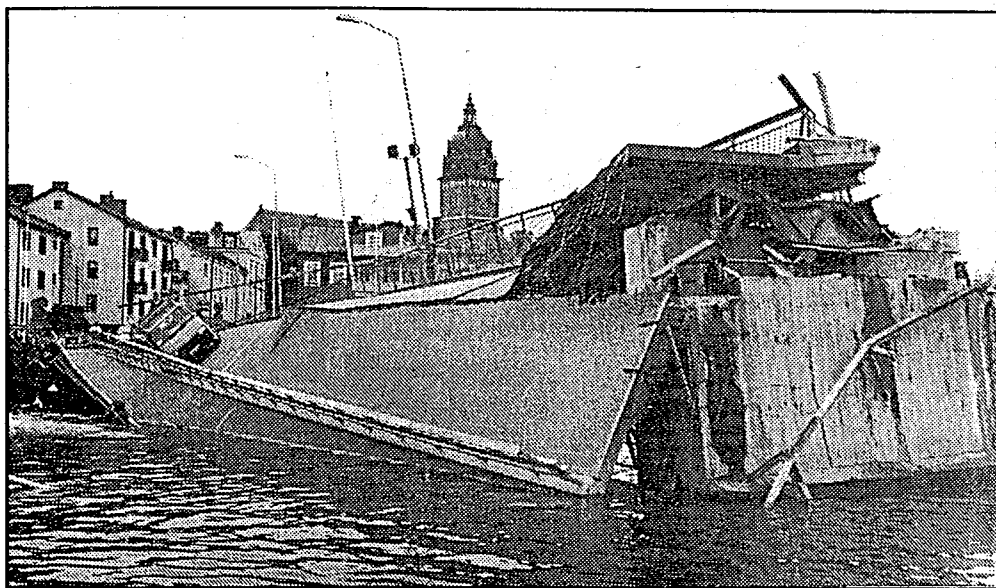

**FIGURE 9.6. THE STRANGNAS BRIDGE ACCIDENT, SWEDEN, 1990**  
(Courtesy of O. D. Larsen, 1994)

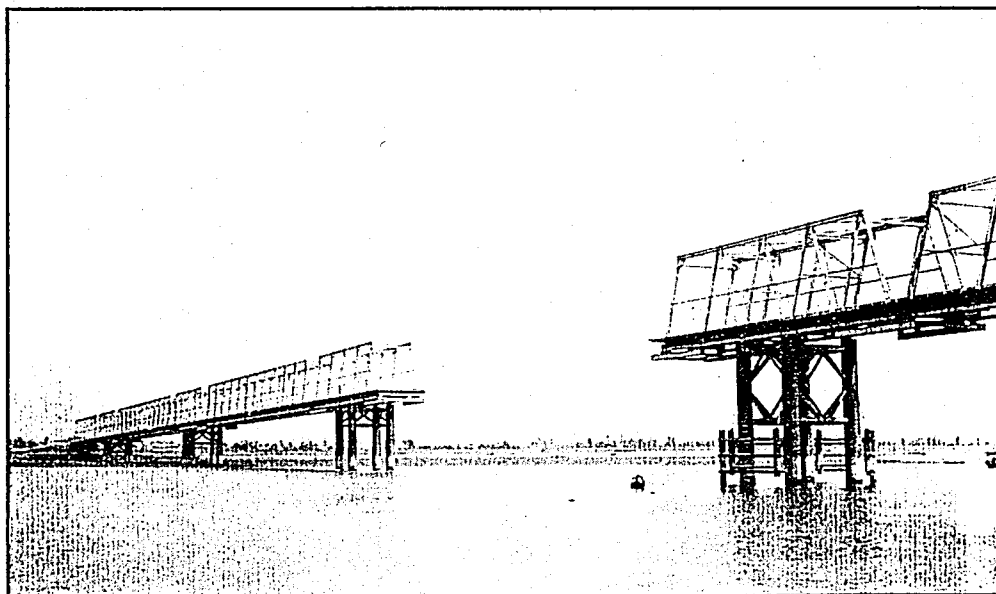

**FIGURE 9.7. THE CARNAFULI BRIDGE ACCIDENT, BURMA, 1991**  
(Courtesy of O. D. Larsen, 1994)

This situation has led to increased concern over the safety of bridges crossing navigable waterways and research into the vessel collision problem has been initiated in several countries of the world in connection with:

- (a) evaluation of vulnerability of existing bridges;
- (b) establishment of design criteria for new bridges;
- (c) development of national codes and specifications regarding vessel/bridge collisions.

## 9.2. Initial Planning

As considerations for the interaction between bridge structures and vessel traffic will often influence fundamental decisions such as location and type of bridge crossing, it is essential that the vessel collision aspects are properly investigated as early as possible in the planning process.

A number of important aspects of the bridge design, sitting, and aids to navigation can be evaluated by relatively simple means on the basis of the initial knowledge of the waterway and the navigation, applying experience and common sense [13].

### A. Sitting of Bridge Structure

The purpose of the bridge often determines a specific location. However, minor modifications can normally be introduced and if major problems are identified it might still be possible to consider alternative locations.

For the sitting of a bridge crossing, the following aspects, among others, should be considered:

- (a) Locations with congested navigation should be avoided.
- (b) Locations with difficult navigation conditions (shoals, cross currents, etc.) should be avoided.
- (c) A straight and unencumbered navigation channel approach of adequate length before the bridge-passage should be achieved.
- (d) Adequate distance to locations where berthing manoeuvres take place should be provided.
- (e) The bridge's alignment should preferably be perpendicular to the navigation channel.
- (f) The center of the navigation span should coincide with the centerline of the navigation channel.
- (g) Locations where bridge piers can be placed in shallow water so that vessels out of control may not reach the bridge structures without first running aground should be preferred.

With regard to the adequate length of unencumbered channel approach, the following empirical estimate has been reported based on analysis of collisions with bridges world-wide: The minimum distance from a bridge line to the position of the nearest turn in the navigation route should be at least  $8L$  and preferably  $20L$ ,  $L$  being the length of the vessel. If the distance is smaller, the turn will influence the navigation at the bridge crossing.

## **B. Navigation Channel Layout**

The aim of the bridge designer to attain optimal safety against vessel collision will as a rule also lead to requirements for the layout and operation of the navigation channel. The bridge designer is, however, often limited in this respect since the responsibility and authority for implementing such navigation improvements often belongs to navigation authorities.

Regardless of the question of design responsibility, the following indicates various aspects of navigation channel layout to be considered by the designer.

- (a) If the waterway should have clearly designed and properly declared navigation channel(s).
- (b) If the traffic density is high, i.e. involving frequent meeting or overturning close to the bridge crossings, two-way traffic should be established by introduction of a traffic separation scheme.
- (c) If conditions allow, the traffic from minor and leisure vessels should be separated from that of large(merchant) vessels.
- (d) The water depth in the navigation channel should be at least 1.2 times the maximum vessel draught.
- (e) The direction of the navigation channel and the location of bends may be adjusted to improve the navigation conditions in general.

## **C. Overall Bridge Layout**

The primary area of vessel collision risk to the bridge is the region near the navigation span. Therefore the layout of the bridge in this region should be developed to maximize the horizontal and vertical clearance for navigation.

The philosophy is that collision with the bridge structures should only occur as a result of navigation error or technical failure on board, possibly in combination with low visibility and adverse weather conditions, and not because of particular navigation difficulties created by the presence of the bridge. It should be realized that all parts of a bridge crossing situated where the water depth allows vessels, including vessels in

ballast, to navigate are exposed to collision risks. The lengths and heights of approach spans should be planned considering these risks.

During the planning phase, thought should also be given to protection alternatives in cases where a cost-effective design of the bridge structure cannot be achieved directly. The alternatives include:

- (a) pier fender systems to reduce impact force and energy;
- (b) independent protection structures, i.e. artificial islands or reefs, dolphins, floating arrestors, etc. to withstand or redirect the colliding vessel.

#### **D. Vertical Clearance**

According to international practice, the vertical clearance in the navigation span of a bridge crossing should be planned to allow the passage of the highest vessel (incl. equipment such as mast, antennae etc.) using the waterway at that point in time when the construction of the bridge is planned and made public to the users of the shipping lane. The clearance should permit the passage of the highest vessel in a ballast condition at high water level due allowance for vertical vessel movements.

The scatter in the vertical dimensions is very considerable as illustrated in *Figure 9.8*. The Figure shows chimney heights, which are less than the required air draught but represent the highest part of the vessels able to damage the bridge in case of collision.

For the existing world fleets of merchant and naval vessels a vertical clearance of 65 meters above high water level will suffice. The vertical clearances of long span bridges world-wide are listed in *Table 9.1* for comparison.

It is to be noted, however, that certain special-purpose vessels, such as crane vessels, offshore drilling rigs during transport and others, may reach more than 100 m above sea level.

#### **E. Horizontal Clearance**

As the risk of vessel collision depends decisively on the horizontal clearance of the navigation span, this should be as large as can be technically and economically justified. An estimate of the horizontal clearance necessary to obtain a high level of safety under normal conditions of passage can be achieved by empirical methods. The following methods are available:

- (a) consultation of literature or codes (may not be reliable and up-to-date);
- (b) analysis based on observations of navigation behavior, e.g. "ship domain";

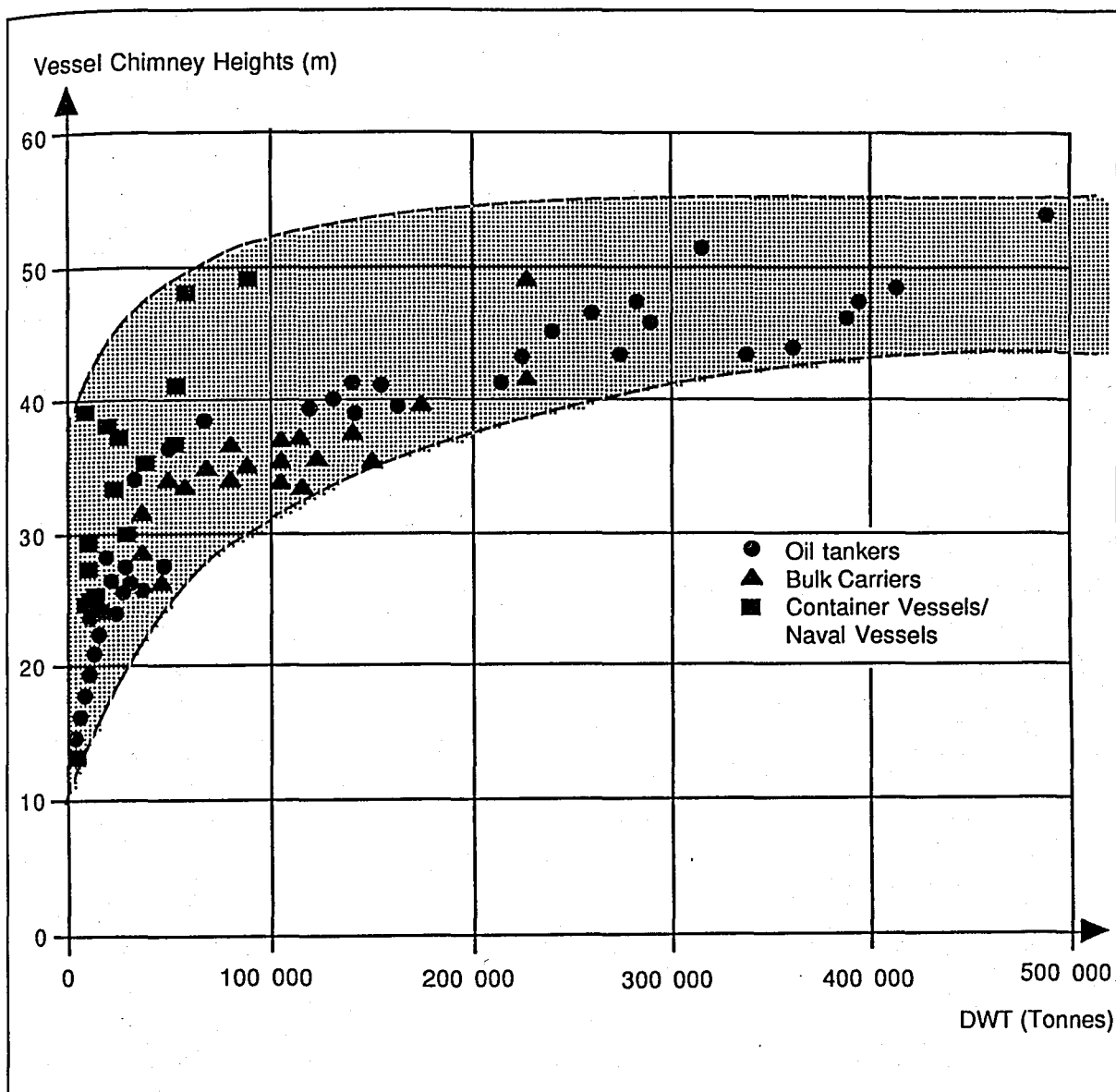

FIGURE 9.8. TYPICAL HEIGHTS OF VESSEL CHIMNEYS

TABLE 9.1. VERTICAL CLEARANCE OF LONG SPAN BRIDGES WORLD-WIDE

| BRIDGE NAME       | COUNTRY                 | COMPLETION YEAR | NAVIGATION SPAN (m) | VERTICAL CLEARANCE (m) |
|-------------------|-------------------------|-----------------|---------------------|------------------------|
| George Washington | U.S.A, New York         | 1931            | 1067                | 65                     |
| West Bay          | U.S.A, California       | 1936            | 704x2               | 65                     |
| Golden Gate       | U.S.A, California       | 1937            | 1280                | 67                     |
| Bronx-Whitestone  | U.S.A, New York         | 1939            | 701                 | 46                     |
| Tacoma-Narrows    | U.S.A, Washington       | 1950            | 853                 | 56                     |
| Mackinac          | U.S.A, Michigan         | 1957            | 1158                | 45                     |
| Forth             | Great Britain, Scotland | 1964            | 1006                | 52                     |
| Verrazano Narrows | U.S.A, New York         | 1964            | 1298                | 69                     |
| Severn            | Great Britain, Scotland | 1966            | 988                 | 37                     |
| Tagus             | Portugal                | 1966            | 1013                | 70                     |
| Angustura         | Venezuela               | 1967            | 712                 | 64                     |
| Kanmon            | Japan, Honshu-Shikoku   | 1973            | 712                 | 61                     |
| Bosphorus (1st)   | Türkiye                 | 1973            | 1074                | 64                     |
| Humber            | Great Britain, Scotland | 1981            | 1410                | 30                     |
| Innoshima         | Japan, Honshu-Shikoku   | 1983            | 770                 | 50                     |
| Ohnaruto          | Japan, Honshu-Shikoku   | 1985            | 876                 | 41                     |
| Minami Bisan-Seto | Japan, Honshu-Shikoku   | 1988            | 1100                | 65                     |
| Kita Bisan-Seto   | Japan, Honshu-Shikoku   | 1988            | 990                 | 65                     |
| Shimotsui-Seto    | Japan, Honshu-Shikoku   | 1988            | 940                 | 31                     |
| Bosphorus (2nd)   | Türkiye                 | 1989            | 1090                | 64                     |

(c) manoeuvring simulations (should be applied after the overall layout of the bridge has been decided).

### E.1. Ship domain analysis

Observations have shown that in order to navigate safely, the master of a vessel tries to keep a certain distance from other vessels, fixed objects, shallow water, etc. The distance varies with the vessel speed, visibility, type of encounter, and a number of other navigational aspects. This method of explaining navigational behavior is called the "Ship Domain" theory.

In this theory, the "Bumper Area" is the area a vessel actually occupies in a waterway including a zone around the vessel within which other vessels' bumper areas should not overlap. Observations shows that vessel encounters with overlapping bumper areas often result in unwanted evasive manoeuvres involving increased accident risk. *Figure 9.9* shows two vessels approaching a bridge with a narrow navigation opening. The indicated sizes of the bumper areas show that the encounter is critical. The estimated size of the bumper area on the basis of data obtained through radar observations are as follows:

(a) For waterways with sufficient width to provide free navigation at service speed (5-8m/sec) and with no obstructions (islands, shallow water, etc.) in the channel, the following average values for the size of the bumper area (approximated by ellipse) has been found:  $8.0L$  in the course direction and  $3.2L$  in the side direction,  $L$  being the length of the vessel.

(b) In narrow channels and harbors, where the conditions require vessels to travel at a reduced speed (3-4 m/sec) and where no head-on encounters or crossing encounters take place, the following average bumper area size has been found:  $6.0L$  in the course direction and  $1.6L$  in the side direction,  $L$  being the length of the vessel.

The above results have been derived from waters with a high traffic density and with a large fraction of small vessels. For confined, protected waterways with very high traffic density, such as narrow rivers or harbor passages, smaller bumper area sizes than mentioned above may be relevant.

For a bridge crossing a navigation channel, it is thus suggested that the requirement for the navigation span clearance should be related to the width of the bumper area of a typical large vessel passing the bridge. The typical large vessel may be selected as the largest vessel which is able to safely pass the bridge without assistance. provided that larger vessels have pilots on board or their passages are regulated by a Vessel Traffic Service System.

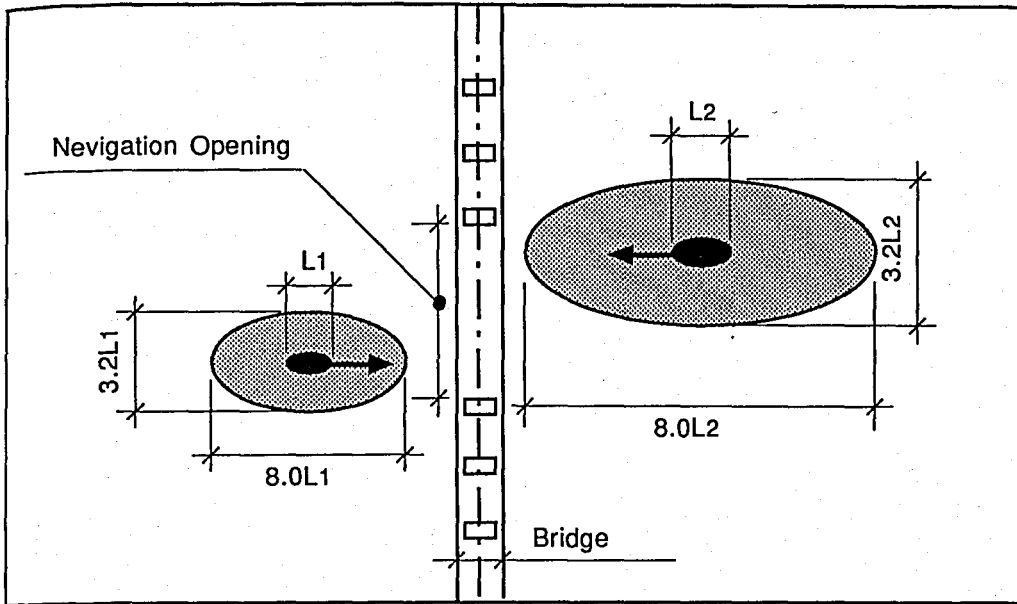

FIGURE 9.9. VESSELS AND RESPECTIVE BUMPER AREAS

Taking the typical large vessel as the design vessel, with the length  $L_D$ , the following requirements for the horizontal clearance of the navigation span may then be derived from the bumper area widths indicated above [13]:

(a) In case of one-way traffic the horizontal clearance  $C$  should be equal to the width of the bumper area of the design vessel, i.e.  $C = 3.2L_D$  for waterways with vessels traveling at service speed and  $C = 1.6L_D$  for restricted waters.

(b) In case of two-way traffic the horizontal clearance should be equal to the width of two bumper areas of two meeting design vessels plus a separation zone between the two bumper areas. The necessary width of separation zone suggests a separation zone width of  $0.3L_D - 1.8L_D$ . Thus, the horizontal clearance  $C$  should be:  $C = 6.7L_D - 8.2L_D$  for waterways with vessels traveling at service speed and  $C = 3.5L_D - 5.0L_D$  for restricted waters.

*Figure 9.10* illustrates the above horizontal clearance indications. It is suggested that these clearance requirements be used in the planning stage for important bridges crossing open deep waters, where it is physically possible for vessels to depart substantially from the normal sailing route.

In addition to these general rules, the local navigation aspects, i.e. risk-increasing effects such as nearby bends and risk-reducing effects such as special navigational aids, should be accounted for.

Most existing bridges do not fulfill the above suggested requirements to the horizontal clearance and for many new bridges, economy does not allow full compliance either.

In cases where the bridges span relatively narrow channels, for which the available width of water deep enough to float large loaded vessels limits the "domain" of these vessels, the suggested requirements are not fully relevant and the collision risk may still be acceptably low.

In other cases where navigation clearances have been dictated by economy rather than collision risk considerations, more cautious navigation practices by vessel masters and pilots are required and attention should be given to collision preventive and protective measures in order to keep the collision risk at an acceptable low level.

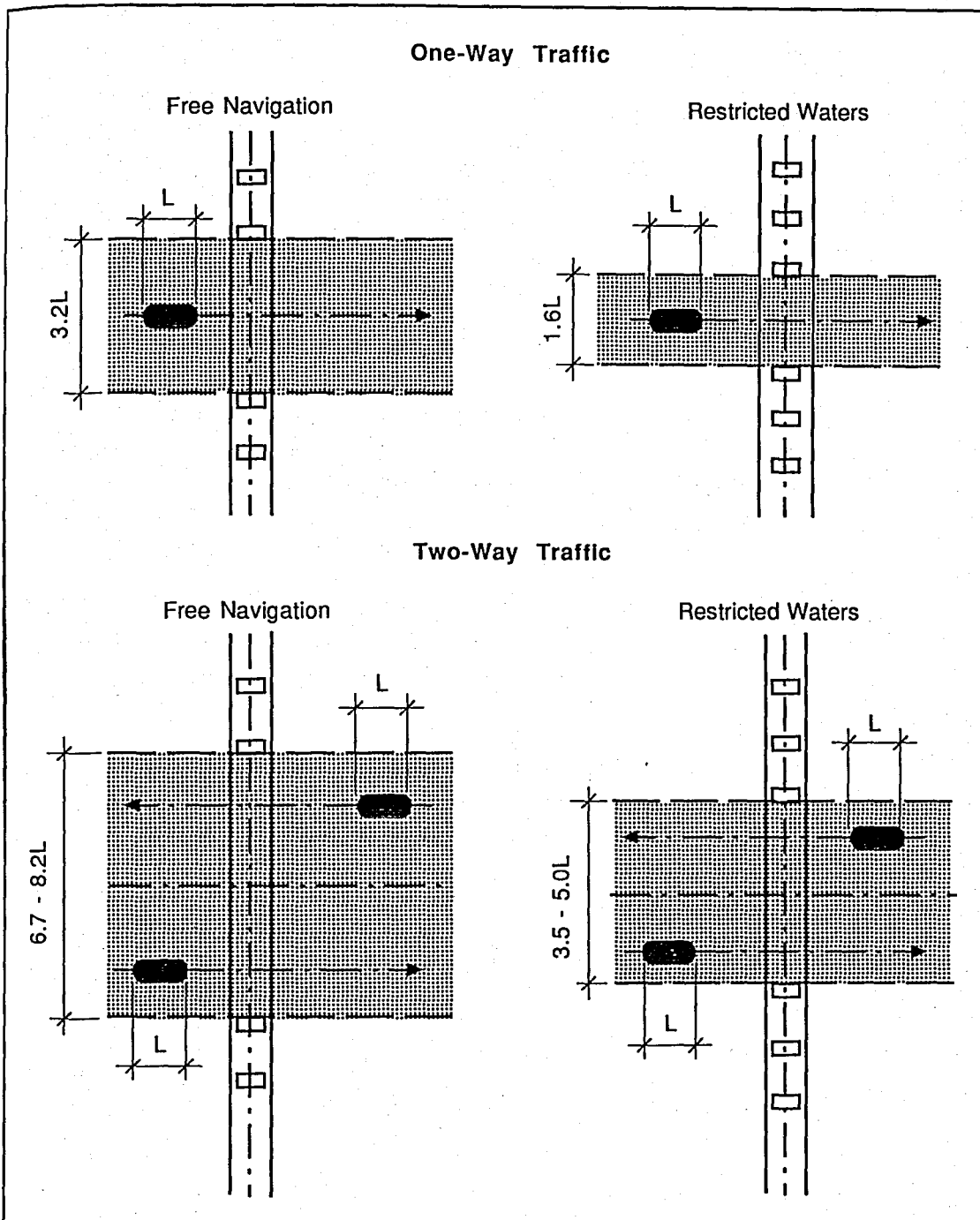

**FIGURE 9.10. HORIZONTAL CLEARANCE REQUIREMENTS FOR IMPORTANT BRIDGES ACCORDING TO THE DOMAIN THEORY**

## **E.2. Manoeuvring simulations with pilots**

Computerized navigation simulators are able to model vessels manoeuvring capabilities very realistically in the sense that it is possible to take most important factors into account as follows:

- (a) wind;
- (b) waves;
- (c) current;
- (d) visibility;
- (e) characteristics of vessels;
- (f) vessel overtaking and meeting;
- (g) geometry of waterway;
- (h) geometry of bridge structures;
- (i) location and type of navigational aids.

This means that pilots are able to navigate almost as if they were sailing a real vessel in a real navigation channel.

Manoeuvring simulations with professional navigators carried out in cooperation between bridge designers and maritime authorities have proven to be an efficient and reliable tool for the evaluation of requirements for horizontal bridge clearances.

## **E.3. Close encounter analysis**

A way to evaluate if the one-way traffic requirement to the navigation span clearance suggested by the domain theory is sufficient is to estimate how often a situation arises where two vessels meet which are so large that the clearance is not sufficient to provide safe passage. Such meetings of anti-directional vessels in the vicinity of the bridge are referred to as "Close Encounters."

Since several of the involved parameters depend on the vessel type and size, it is convenient to use a Monte Carlo simulation approach in order to calculate the yearly expected number of close vessel encounters as a function of the horizontal clearance of the bridge.

The simulation of the occurrence of vessels of different sizes in the vicinity of the bridge requires a statistical description of the vessel traffic. The Poisson process is generally accepted as a relevant description of such events. Final advice about an acceptable level of annual number of close encounters for maintaining one-way conditions cannot generally be given, but should be defined in the particular case by the authority concerned.

### 9.3. Prevention Measures

Planning and implementation of prevention measures to improve safe navigation in the water-way near a bridge crossing requires close cooperation with the relevant navigation authorities. Where the matter is of international concern, the national authorities will approach the international authorities, in most cases the International Maritime Organization (IMO).

Prevention or reduction of the frequency of collisions is achieved by providing assistance to navigation. The assistance may differ in extent and level of sophistication, depending on the waterway and the intensity of the navigation. Three levels of assistance are discussed in the following [13]:

- (a) installation of navigational aids on the bridge and in the waterway;
- (b) introduction of navigation regulations;
- (c) implementation of a vessel traffic management system;

#### A. Aids to Navigation

Visual, sonar as well as electronic aids to navigation should be designed to provide safe guidance in most weather conditions.

For installation on the bridge structure, the following types of navigational aids can be considered to provide better detectability:

- (a) colors (fluorescent);
- (b) signs;
- (c) high intensity light beacons (flashing);
- (c) range lights;
- (d) sound devices (fog horns);
- (e) racon installation at the center line of the vessel track(s).

An example of installations on a bridge to aid navigation is shown in *Figure 9.11*. For location in the waterway near the bridge crossing, the following types of navigational aids can be considered:

- (a) lighthouse;
- (b) buoys;
- (c) beacons
- (d) racon installations

Fewer but larger buoys with strong lights and fluorescent paint should be utilized rather than many small buoys. Racons (self - identifying radio beacons activated by the

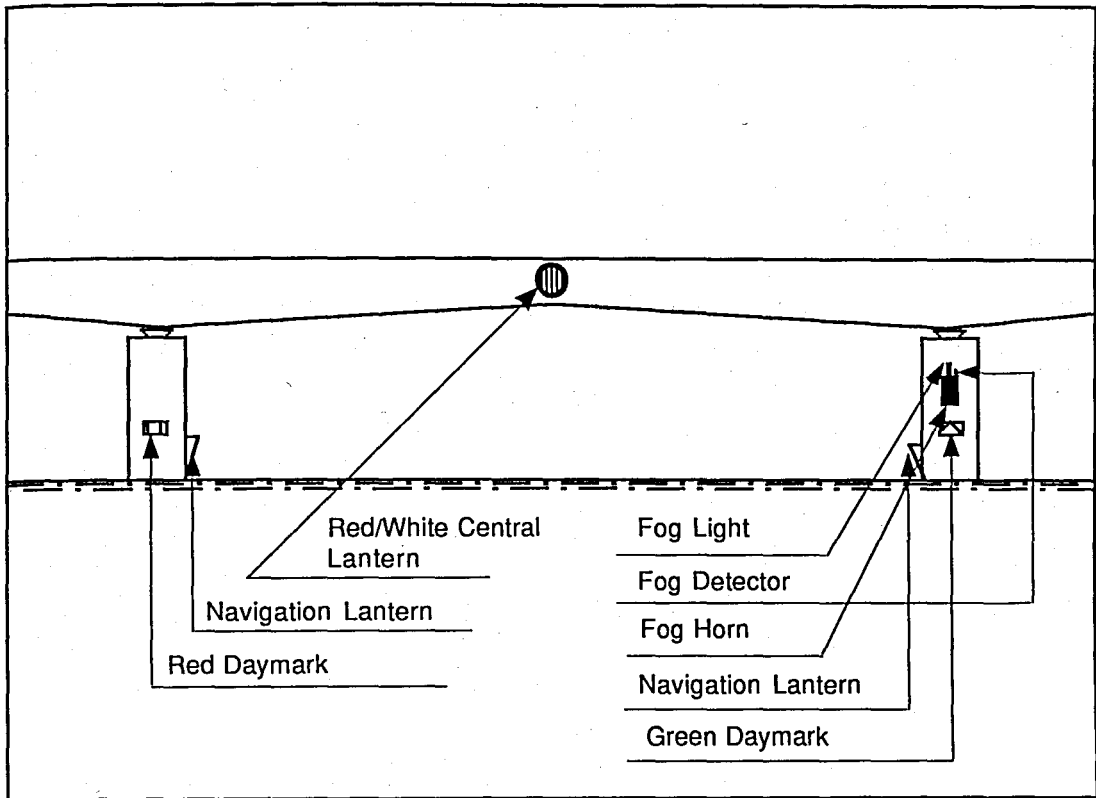

**FIGURE 9.11. NAVIGATION EQUIPMENT MOUNTED ON THE NAVIGATION SPAN OF THE GREAT BELT WESTERN BRIDGE**

radar signals of passing vessels) should always be installed in connection with critical bridge passages.

## B. Vessel Traffic Regulations

Traffic regulation measures should be studied in cooperation with local navigation authorities. The regulations may involve both mandatory and voluntary elements. Different possibilities exist :

- (a) separation of navigation routes for opposite traveling directions;
- (b) limitation of maximum vessel speed (it should be remembered that the manoeuvring capabilities of a vessel are reduced with reduced speed);
- (c) requirement for pilotage (in national waters it is possible to introduce compulsory pilotage, whereas international waters require involvement of relevant organizations such as IMO);
- (d) requirement for tug assistance (the comments related to pilotage also apply to tug assistance);
- (e) restriction on passage in bad weather or bad sea conditions;
- (f) limitation of maximum vessel size;
- (g) restriction on passages of large vessels to daylight transit only;
- (h) demand on empty vessels to take on ballast for a minimum draught;
- ( ) special demands on vessels with hazardous cargoes.

## C. Vessel Traffic Management Systems

Traffic management systems of varying sophistication can be considered including facilities as follows:

- (a) radar surveillance;
- (b) guard boat surveillance;
- (c) transmission from data buoys of information on meteorological conditions, sea and tide, etc.;
- (d) transmission of navigational information;
- (e) navigational guidance by pilots directly or over radio;
- (f) radio communication between vessel and bridge personnel.

The management system should cover the navigation channel in full width within a distance sailed in one hour, i.e. approximately 15 nautical miles on both sides of the navigation span. The Vessel Traffic Management System planned for the Great Belt crossing is shown in *Figure 9.12*.

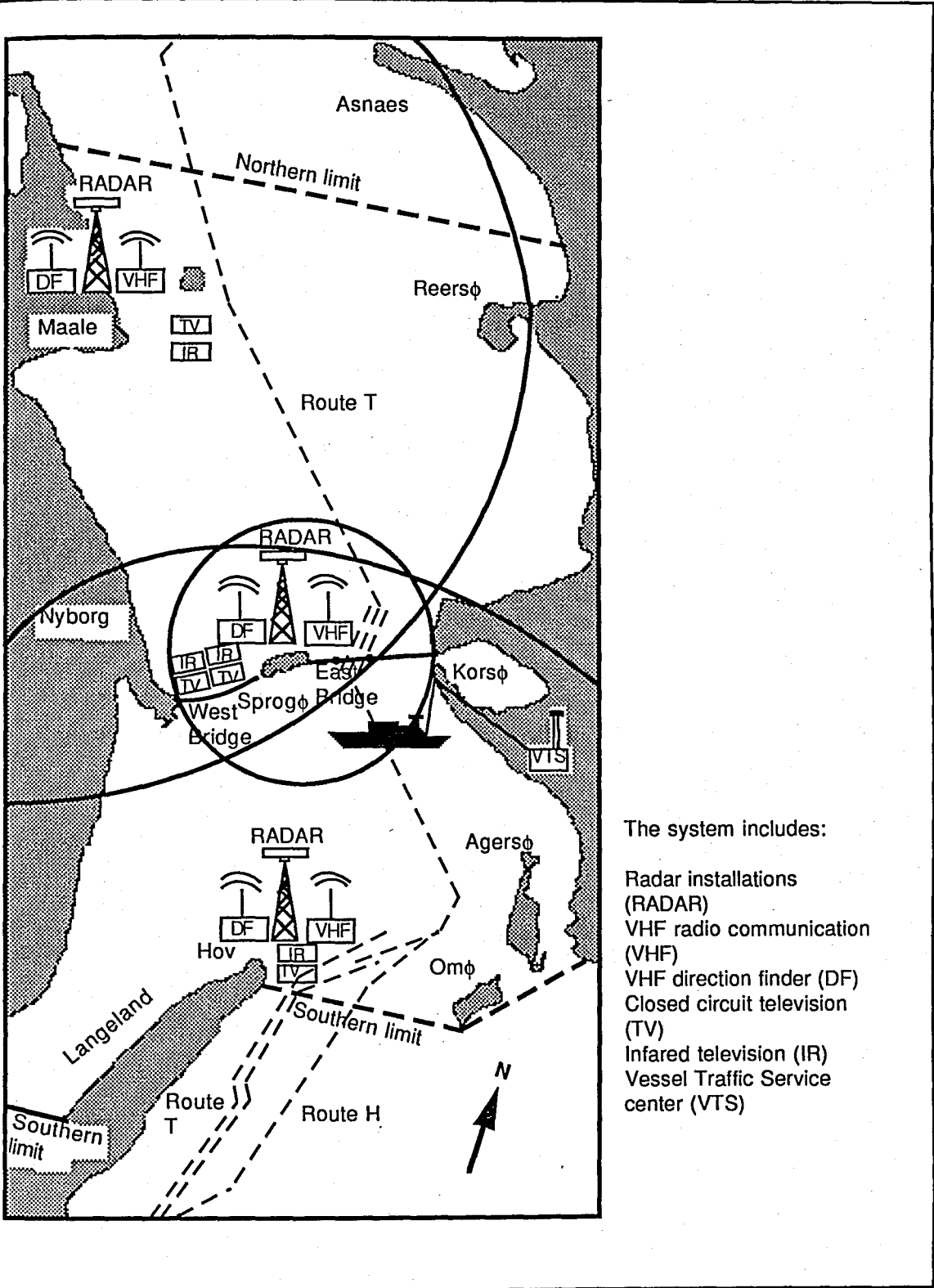

- The system includes:
- Radar installations (RADAR)
  - VHF radio communication (VHF)
  - VHF direction finder (DF)
  - Closed circuit television (TV)
  - Infrared television (IR)
  - Vessel Traffic Service center (VTS)

FIGURE 9.12. OUTLINE OF VTS SYSTEM COVERING THE WATERS OF THE GREAT BELT IN DENMARK

### 9.3. Protection Measures

In addition to bridge damage, vessel collisions may result in serious environmental damage such as the spilling of oil and other chemicals. The consequences of a vessel collision may therefore reach far beyond the direct costs of repairing/replacing the vessel and possibly the bridge.

The bridge elements can be designed to withstand the impact loads, or a fender or a protection system can be developed to prevent, redirect, or reduce the impact loads on bridge elements to non-destructive levels. If the force resistance of the protection system is higher than the vessel crushing force, the bow of the vessel will crush and the impact energy will be primarily absorbed by the vessel [13].

If the vessel crushing force is higher than the resistance of the protection system, the impact energy will be primarily absorbed by the deflection and crushing of the protection system.

The protection system should be designed not only to protect the bridge structure, but also to protect the vessel and the environment against serious damage. This may be achieved by combining different types of protective systems.

Protection systems may be located directly on the bridge structure (such as a bridge pier fender), or independent of the bridge (such as a dolphin). The geometry of the protective structure should be developed to prevent the rake (overhang) of the design vessel's bow from striking and causing damage to any exposed portion of the bridge. Generally, the analysis and design of bridge protection structures requires the use of engineering judgment to arrive at a reasonable solution.

The various types of protective structures commonly used for bridges will be briefly discussed in the subsections below:

- (a) Fender Systems;
- (b) Pile Supported systems;
- (c) Dolphin Protection;
- (d) Artificial Island or Reef Protection;
- (e) Floating Protection Systems.

#### A. Fender Systems

Timber fenders are composed of vertical and horizontal timber members in a grillage geometry attached to the face of the bridge pier, or erected as an independent structure adjacent to the pier. Energy is absorbed by elastic deformation and crushing of

the timber members. Because of their relatively low cost, timber fenders have frequently been used on bridge projects for protecting piers from minor vessel impact forces. However, for relatively large collision impact loads the resulting timber fenders would have to be extremely large, and might be uneconomical in most circumstances.

Rubber fenders are commercially available in a wide variety of extruded and built-up shapes. Impact energy is absorbed through the elastic deformation of the rubber elements either in compression, bending, shear deformations, or a combination of all three.

Concrete fenders consist of hollow, thin-walled, concrete box structures attached to bridge pier. Usually, a timber fender is also attached to the outer face of the concrete box fender. Impact energy is absorbed by the buckling and crushing of the concrete walls composing the fender system. An example of this type of fender is shown in *Figure 9.13*.

Steel fenders consist of thin-walled membranes and bracing elements composed in a variety of box-like arrays and assemblies attached to the bridge pier. Impact energy is absorbed by compression, bending, and buckling of the steel elements in the fender. Timber facing should be attached to the steel fender to prevent sparks resulting from direct contact with steel hulled vessels. An example of this type of fender is shown in *Figure 9.14*.

## **B. Pile Supported Systems**

Pile groups connected together by rigid caps may be used for protection to resist vessel impact forces. Free standing piles and piles connected by relatively flexible caps are also used for bridge protection. The pile groups may consist of vertical piles, which primarily absorb energy by bending, or batter piles which absorb energy by compression and bending.

As a result to the high impact design loads associated with vessel collision, plastic deformation and crushing of the pile structure is permitted provided that the vessel is stopped before striking the pier, or the resulting impact is below the resistance strength of the pier and foundation. Fender systems may be attached to the pile structure to help resist a portion of the impact loads. Timber, steel, or concrete piles may be utilized depending on site conditions, impact loads, and economics. An example of this type of protective structure is shown in *Figure 9.15*.

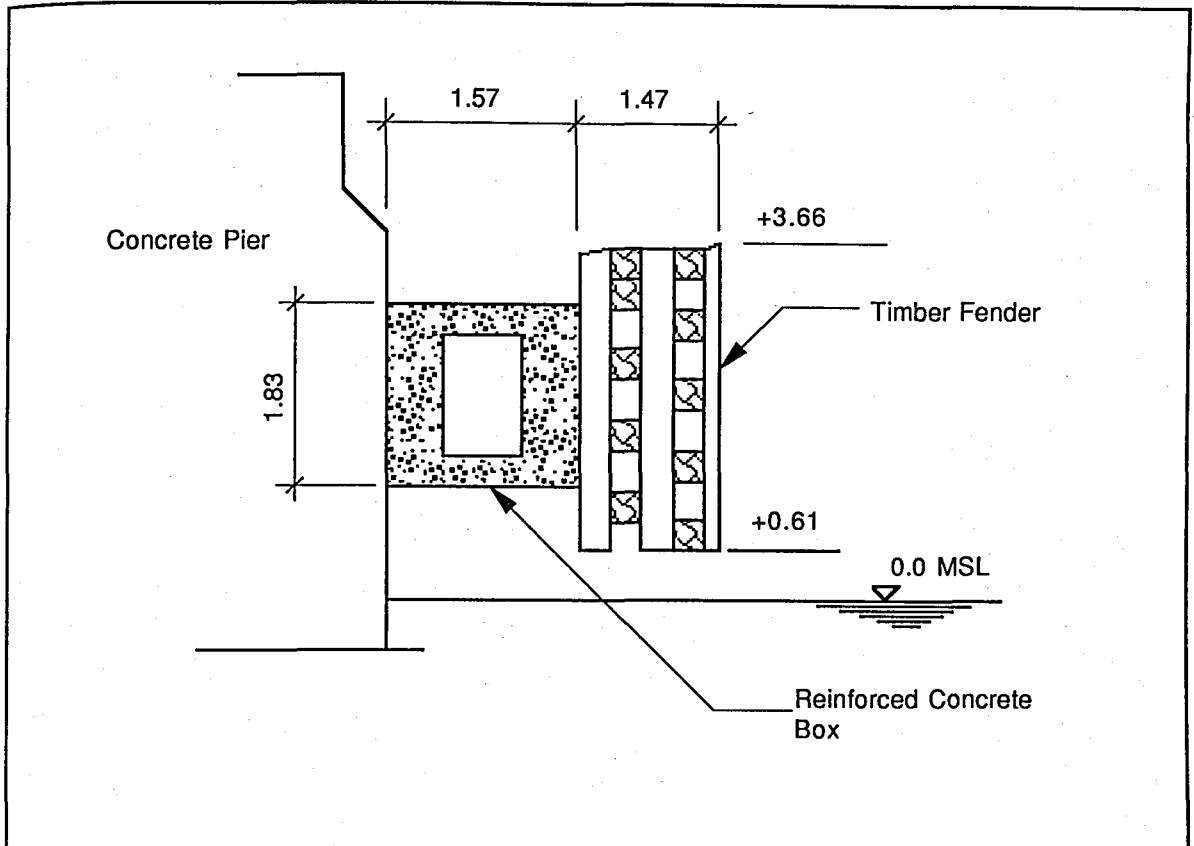

**FIGURE 9.13. CRUSHABLE CONCRETE BOX FENDER ON THE FRANCIS SCOTT KEY BRIDGE, BALTIMORE, USA (In meters)**

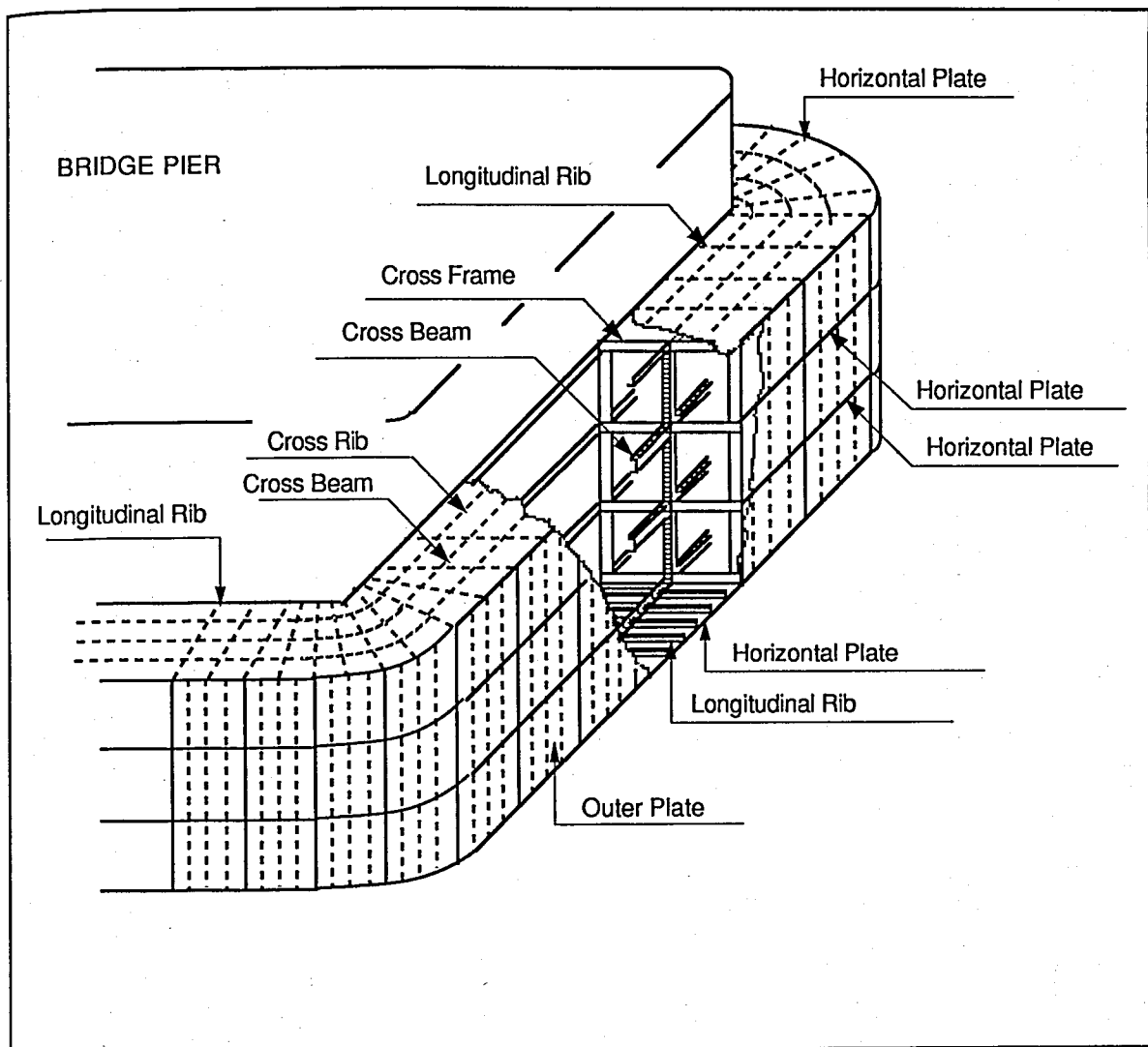

**FIGURE 9.14. FRAMED STEEL FENDER SYSTEM USED FOR PROTECTION OF THE BISAN-SETO BRIDGES, JAPAN**

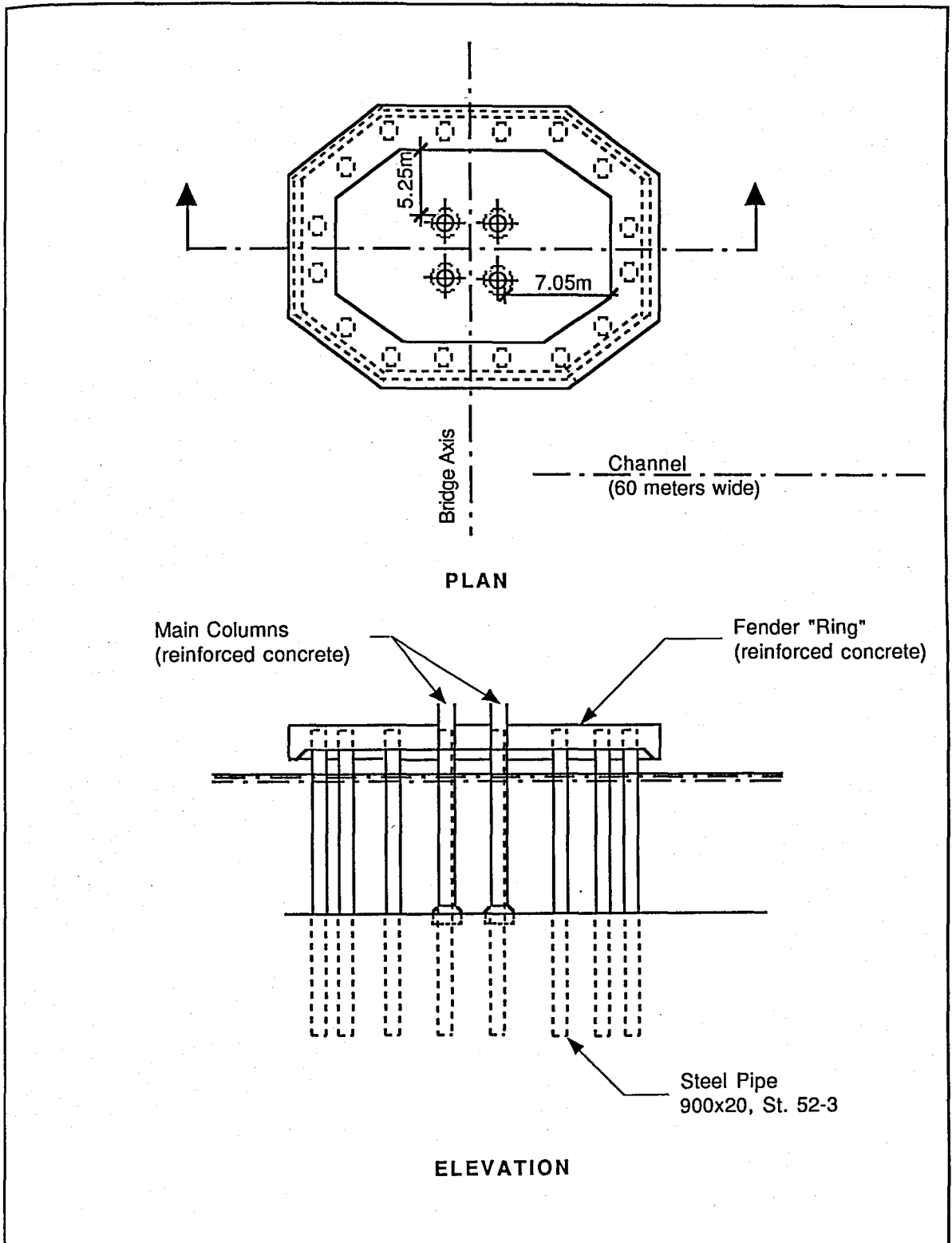

**FIGURE 9.15. PILE SUPPORTED PROTECTION SYSTEM FOR THE TOMSO BRIDGE, NORWAY**

### C. Dolphin Protection

Large diameter dolphins may be used for protection of bridge piers. Dolphins are typically circular cells constructed of driven steel sheet piling, filled with rock or concrete, and topped by a concrete cap. Dolphins may also be constructed of precast concrete sections, or precast entirely off-site and floated into final position.

Driven pilings are sometimes incorporated in the cell design. Design procedures for dolphins are usually based on an estimate of the energy changes that take place during the design impact loading. Energy-displacement relationships are typically developed for the following energy dissipating mechanisms:

- (a) crushing of the vessel's bow;
- (b) lifting of the vessel's bow;
- (c) generation of water waves and turbulence;
- (d) friction between the vessel and the dolphin;
- (e) friction between the vessel and the river bottom;
- (f) sliding of the dolphin;
- (g) rotation of the dolphin;
- (h) deformation of the dolphin.

Deformation of the vessel/dolphin system is assumed to follow a path of least energy. For each potential displacement configuration of dolphin and vessel, a deformation path can be developed. Deformation stops when all the kinetic energy of the impact has been absorbed.

For purposes of design, it is recommended that the maximum dolphin deformation be limited to less than one-half the diameter of the cell. Under design loading conditions, the cell is permitted to undergo large plastic deformation and partial collapse. An example of this type of protective structure is shown in *Figure 9.16*.

### D. Artificial Island or Reef Protection

Artificial islands round bridge piers or artificial reefs in front of bridge piers provide highly effective vessel collision protection. If the waterflow through the navigation channel is important to the surrounding environment, investigations about the net waterflow before and after installation of the protection islands should be carried out. Islands typically consist of a sand or rock core which is protected by outer layers of heavy rock armor to provide protection against wave, current, and ice actions. The island geometry should be developed in accordance with the following criteria:

- (a) The vessel impact force transmitted through the island to the bridge pier must not exceed the lateral capacity of the pier and pier foundation.

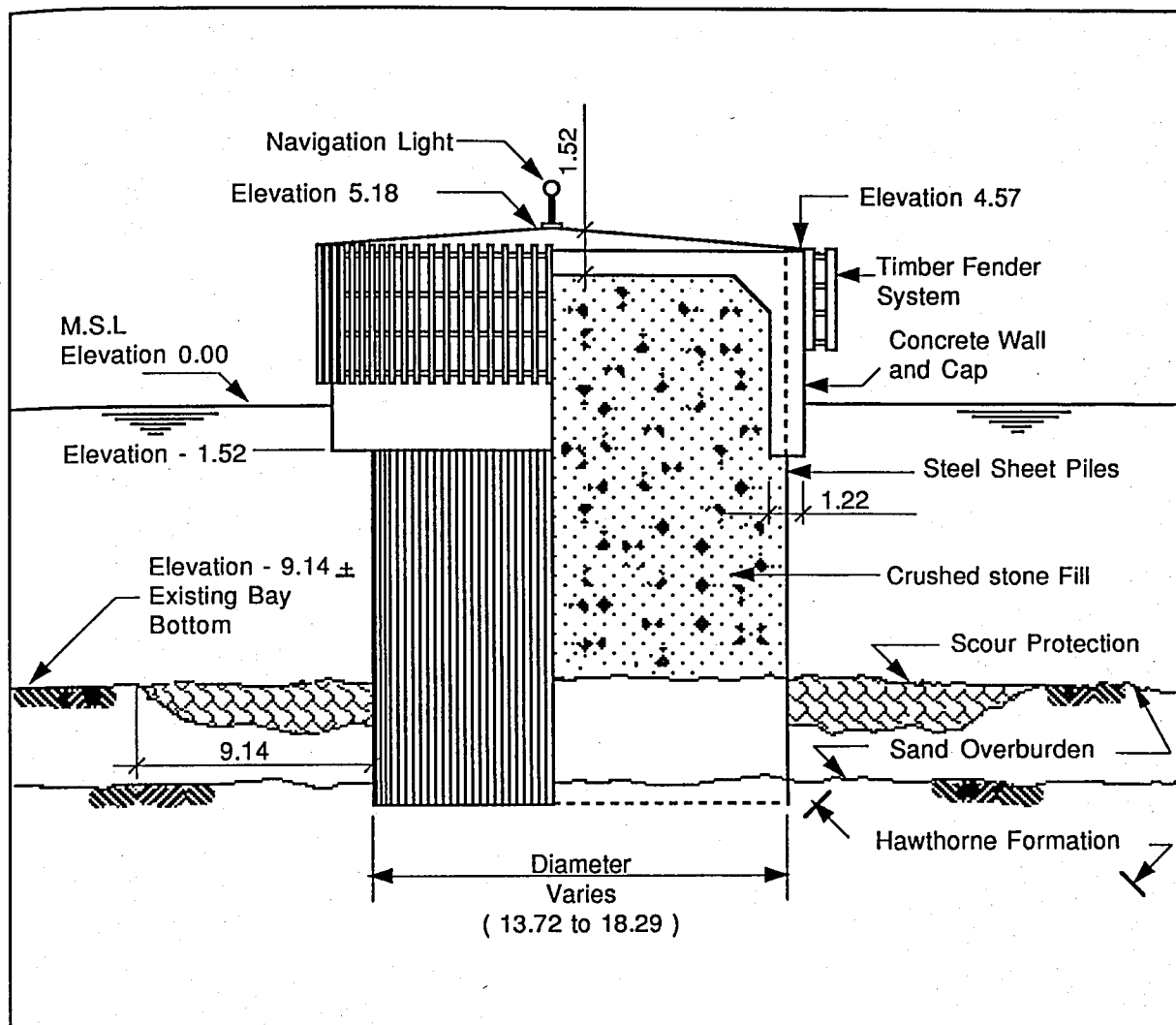

**FIGURE 9.16. DOLPHIN PROTECTION OF THE SUNSHINE SKYWAY BRIDGE, FLORIDA, USA (In meters)**

(b) The island dimensions should be such that vessel penetration into the island during the collision will not result in physical contact between the vessel and any part of the bridge pier.

The second requirement is particularly critical for empty or ballasted ships and barges which can slide up on the slopes of an island and travel relatively large distances before coming to a stop. The design of the surface armor protection of the islands for wave, current, and ice attack may be based on methodologies user for rubble mound breakwater design. The following items have been identified as sources of energy absorption/dissipation during a vessel impact with an island:

- (a) crushing of the hull of the vessel;
- (b) lifting of the vessel;
- (c) generation of water waves and turbulence;
- (d) lifting of island material;
- (e) displacement, shear, and compaction of the island material;
- (f) friction between the vessel and the island;
- (g) generation of the shock waves in the island;
- (h) crushing of particles of island material.

Inclusion of these items in a design analysis is difficult since their effects are only partially understood. Physical model studies, as well as mathematical simulations, are usually required when protective islands are designed. An example of the arrangement of artificial islands for vessel collision protection is shown in *Figure 9.17*.

## E. Floating Protection Systems

Various types of floating protective systems may be considered by the engineer. Several of these systems include:

- (a) Cable net systems. Vessels are stopped by a system of cables anchored to the waterway bottom and suspended by buoys located in front of the bridge piers.
- (b) Anchored pontoons. Large floating pontoons anchored to the waterway bottom in front of the piers absorb vessel impact.
- (c) Floating Shear Booms. Floating structures anchored to the waterway bottom deflect vessels away from piers and absorb impact energy.

Special consideration for corrosion protection must be made for all systems involving underwater steel cables and anchorages. Special consideration should be given to the function and vulnerability/durability of floating systems during winter time in waters subject to icing or ice drift. Floating systems are vulnerable to overrun by vessels with sharply raked bows. An example of cable net system is shown in *Figure 9.18*.

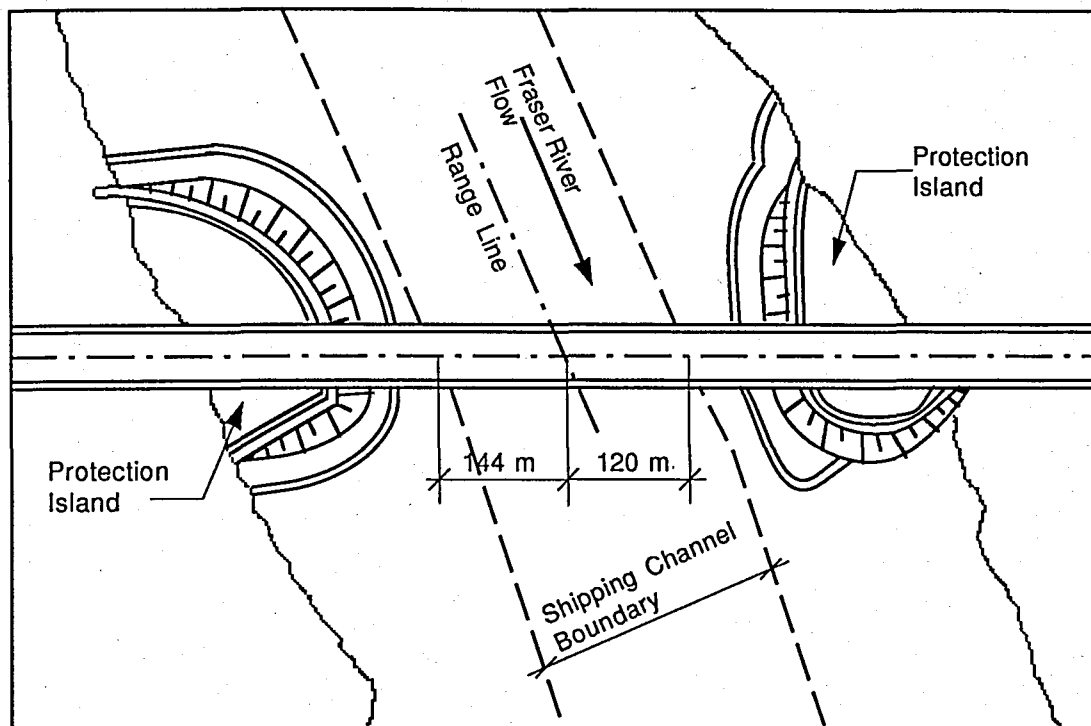

**FIGURE 9.17. ARRANGEMENT OF PROTECTION ISLANDS FOR THE ANNACIS ISLAND BRIDGE, VANCOUVER, CANADA**

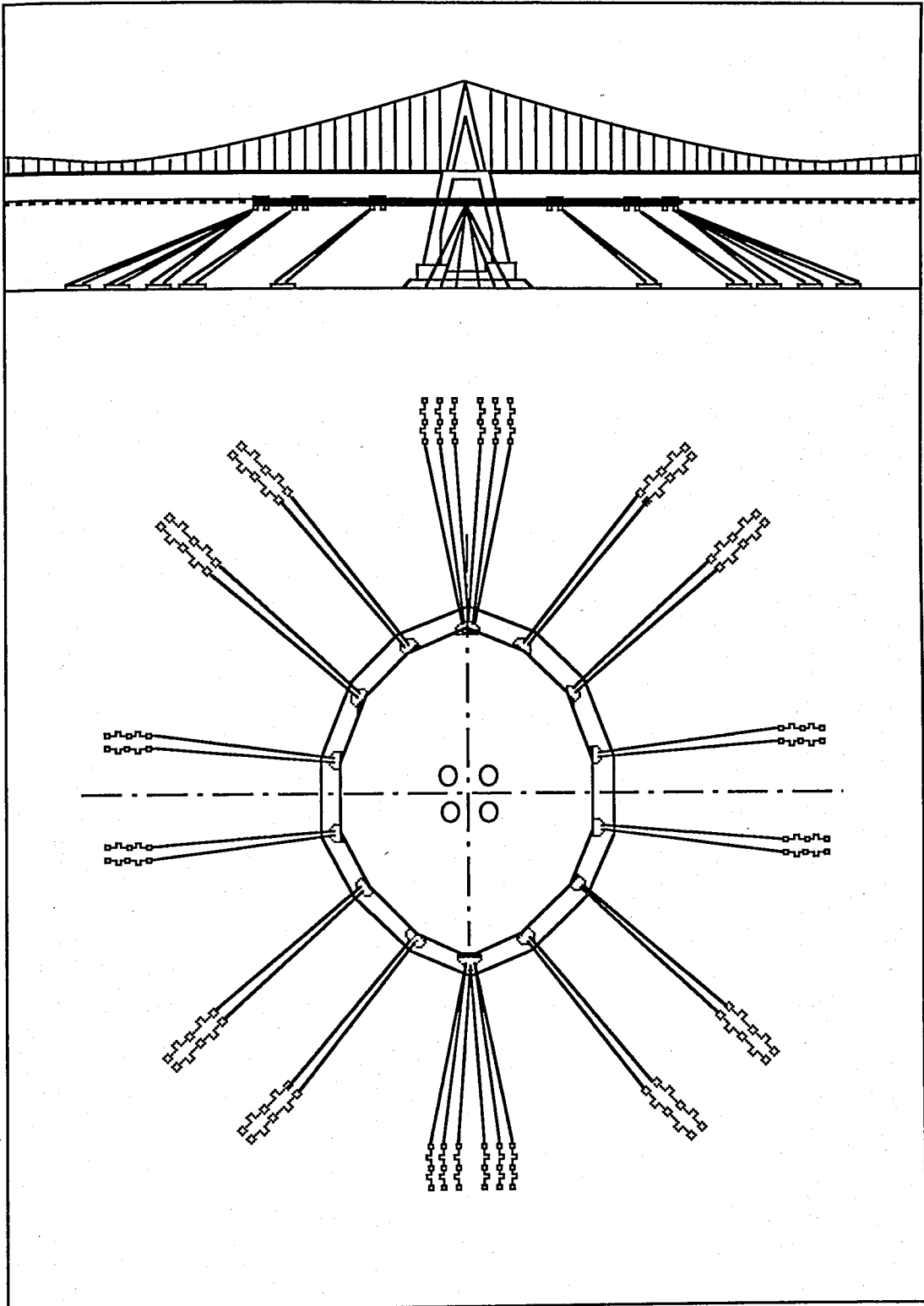

FIGURE 9.18. PROPOSED CABLE NET SYSTEM FOR THE GIBRALTAR BRIDGE

## **10. CASE STUDY NO.1**

### ***SKARSUNDET & HELGELAND CABLE-STAYED BRIDGES IN NORWAY***

#### **10.1. Introduction**

Skarnsundet bridge has the second longest main span of 530 meters in the world, Helgeland bridge has a span of 425 meters. Both bridges are located relatively close together at the coast, in the middle of Norway. These bridges are consequently subjected to severe marine environments, high winds, salt spray and temperature differences. This is especially true for Helgeland bridge, where winter conditions are particularly severe. These bridges replace the previous ferry connections, the traffic being less than 1000 vehicles per day only carried for two lanes. The bridges with their long spans are therefore very slender giving good reasons for close following up maintenance. Both bridges were partly financed by road toll [14], [15], [16].

#### **10.2. Skarnsundet Bridge**

The Skarnsundet Bridge shown in *Figure 10.1* and *Figure 10.2*, is a closed box section cable-stayed bridge having a main span of 530 meters and equal side spans of 90 meters each. The Skarnsundet Bridge was built to provide a road connection over the inner part of the Trondheimsfjord north of Trondheim. As there are only two traffic lanes the bridge has a very slim structure relative to the length of span. During tendering, before the start of construction, a normal suspension bridge was considered. However, the stayed-cable solution proved to be cheapest [14], [15].

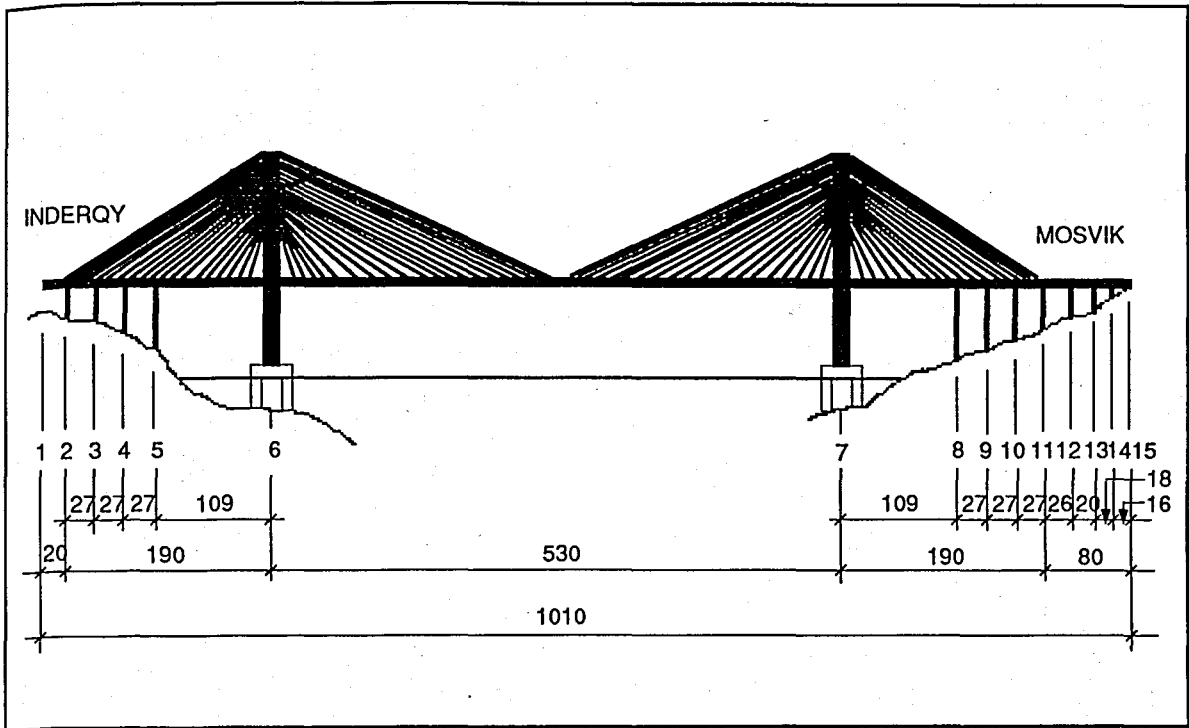
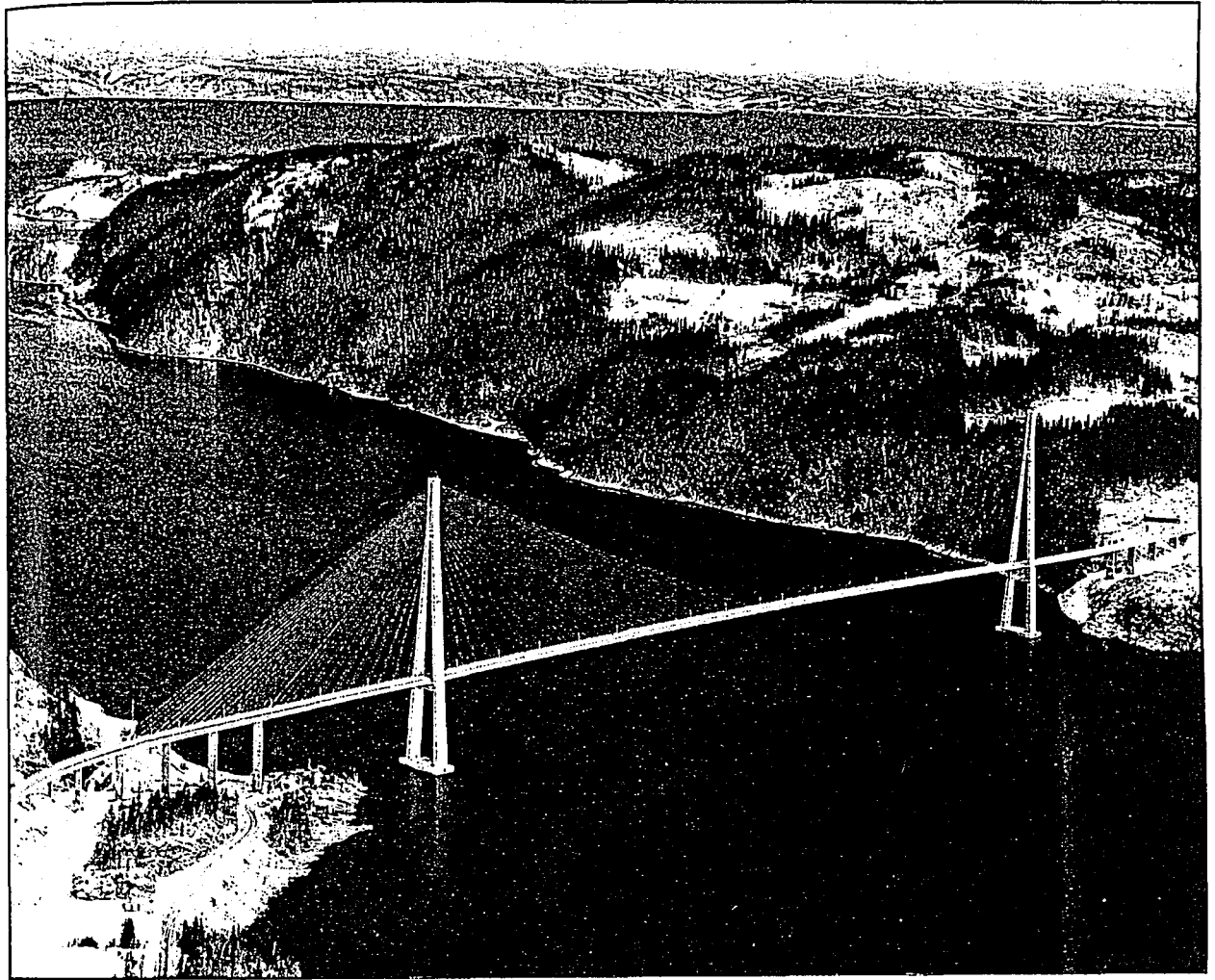

FIGURE 10.1. ELEVATION (In meters)



**FIGURE 10.2. SKARNSUNDET BRIDGE, NORWAY (Courtesy of P. Schoen, 1993)**

## A. Bridge Superstructure

The bridge deck in stayed spans, shown in *Figure 10.3*, is a thin-walled box girder of triangular shape. In the approach spans outside the anchor zones, the bridge deck consists of a simple double web concrete girder.

The bridge cross-section accommodates two traffic lanes of width 7.0 meters and a bicycle lane of width 2.5 meters separated from the roadway by rails. This gave a total width of the bridge deck of 13 meters in spans with stay anchorages. A wear layer of 30mm is included in the cover to reinforcement in the traffic and bicycle lanes. The design also allows for an extra asphalt layer if so desired.

## B. Towers

The tower is an A-shaped frame structure as shown in *Figure 10.4*. The total height above water level is 152 meters. The individual legs join at elevation 120.0 into a double cell structure housing the stay anchorages. The transverse beam at elevation +45 has a dual function of supporting the bridge deck and reducing the slenderness of the tower legs to acceptable values.

The tower foundation structure consists of four individual footings interconnected at their top by a heavy slab structure. The cross-section of the footings is 4x4 meters increasing to 6x6 meters at the foundation level. Water depth is in average 15 meters and 25 meters for axis 6 and 7 respectively.

## C. Cables

A total number of 208 cables support the bridge. The cables are of the locked coil type varying in size from 52mm to 83mm. Both the internal wires of circular shape and the external wires of Z-shape are galvanized.

Locked coil cables have been successfully used in several suspension bridges for many years in Norway. They were preferred by the client prior to the approximately USD 0.9 mill. cheaper parallel-strands systems also tendered.

## D. Construction

The construction period was planned for two and a half years, three summer seasons and two winter seasons. This is made it possible use only one set of form equipment by starting construction on one side and finishing, then moving the equipment to the other side and completing the construction.

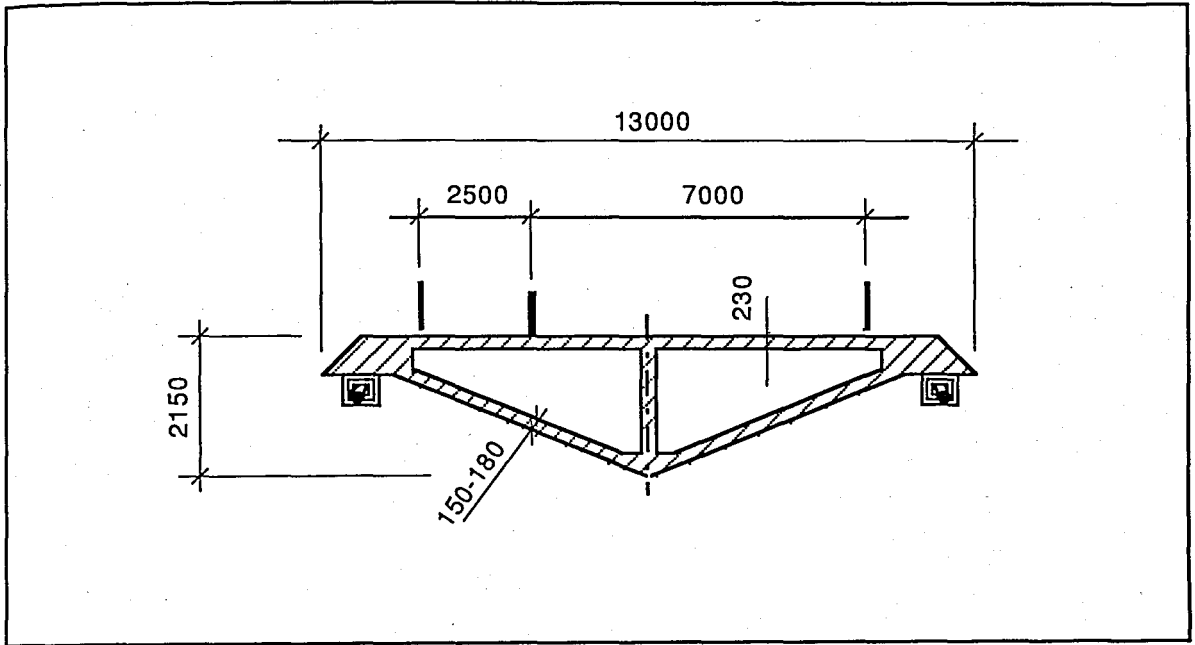

FIGURE 10.3. CROSS SECTION OF THE BRIDGE DECK (in meters)

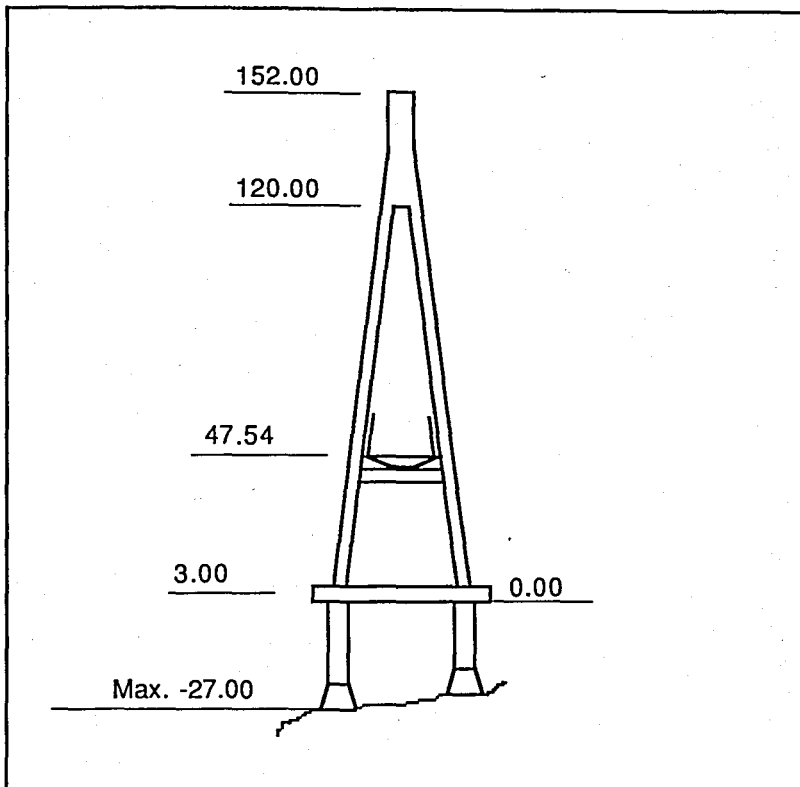

FIGURE 10.4. MAIN TOWER (In meters)

This proceeded as planned, but resulted in continues construction work throughout the last half of the construction period, owing the time lost on foundation work below sea level.

Weather conditions throughout the construction period was very good, low winds and just a little snow with only short periods of sub zero temperatures. The formwork was insulated and there was very little demand for heating.

Towers and piers were constructed by slipforming. Even for the complicated top part of the tower continuous slipforming was used. The bridge superstructure was made of concrete casted in place. In the approach spans ordinary formwork was used. The stayed part of the bridge was erected by the free cantilevering method using a pair of heavy form travelers. The construction sequence shown in *Figure 10.5* is as follows:

*Stage 1* is represented by pylon with 100 m cantilever to both sides including loads from traveling formwork and wind load. This situation is governing the pylon design.

*Stage 2* is represented by the maximum cantilever length before final connection of main span. This situation governs the design of the bridge deck.

*Stage 3* represents the bridge completed and governs design of minor local elements only.

Stage 1 is also shown in *Figure 10.6*.

Later check with removal of the outer skin of the towers by sandblasting, revealed some "lifting cracks" and the owner will not in future use the slip form method for structures in severe coastal environments.

One problem was the weight of the stepping formwork about 150 t, which called for extra reinforcement in the bridge deck. The protection of the formwork with tent also resulted in large wind - induced forces, especially in situations with a long cantilever. Construction-work was continues, but in spite of this, the installation of cables were never time critical.

Movements of the cables during the construction period occurred, but was never a major problem. The movements were small and easy to stop. After construction was completed, formwork removed and the neoprene dampers installed, the movements of the cables are very small. No secondary stiffening fo the cables has been necessary.

During construction it was decided to increase the concrete strength from C45 to C60 over a 200 meters long section in the mid span.. This reduced the compression reinforcement. This turned out to be a disappointment as considerable cracking of the

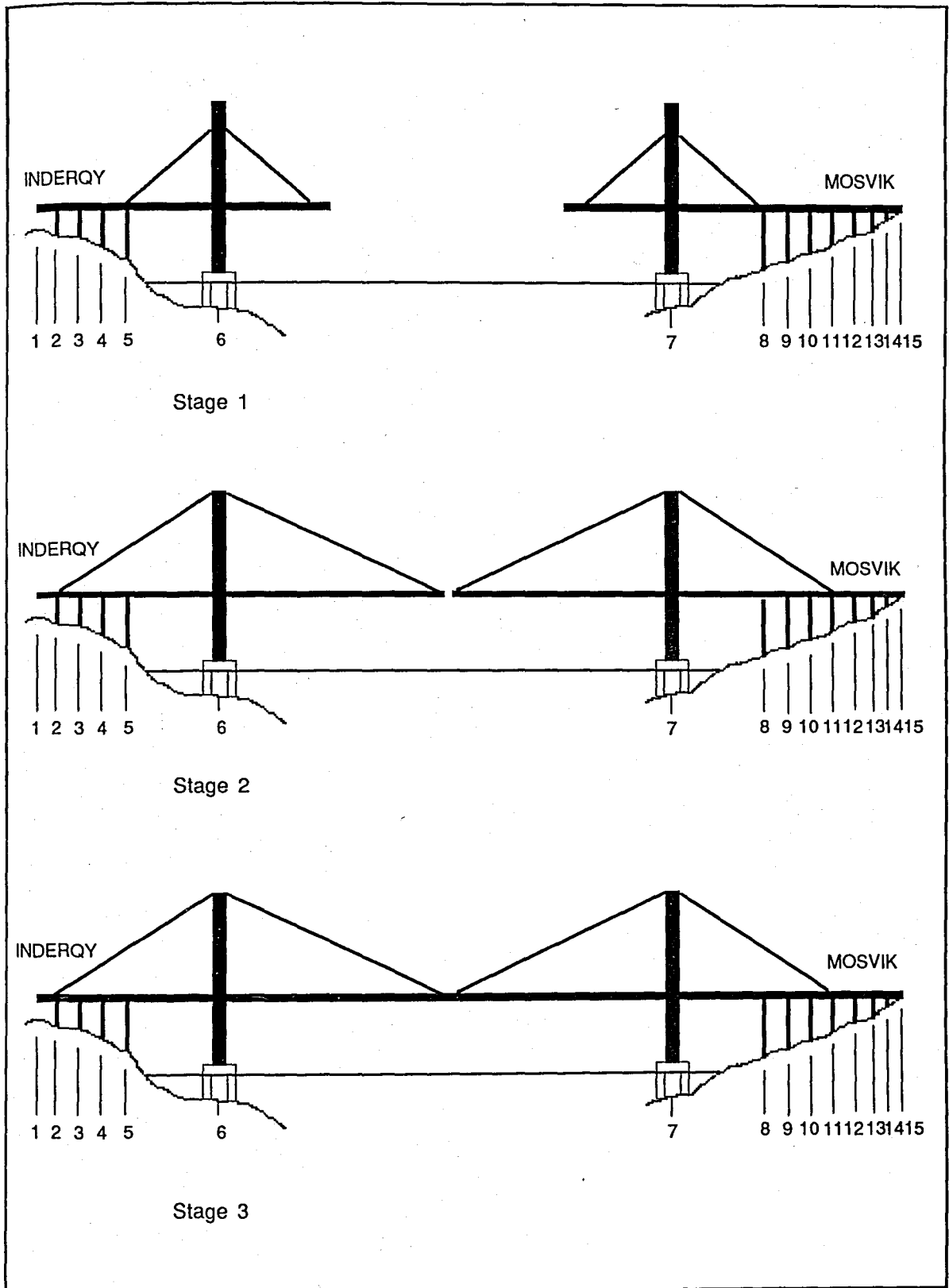

FIGURE 10.5. CONSTRUCTION PROCEDURE



**FIGURE 10.6. ERECTION OF THE GIRDER** (*Courtesy of S. Vegvesen, 1994*)

concrete occurred. These cracks developed in an early phase after placement of the concrete and proved to be impossible to avoid. The cracks were repaired by epoxy.

#### **E. Cost and Financing**

Total cost for adjacent road and bridge was USD 31 mill, the bridge itself USD 29 mill. 30 per cent is privately financed by a share holding company also responsible for the toll system. The project will be paid for in about 15 years.

#### **F. Operation and Maintenance**

The cables were painted during the summer seasons of -92 and -93 when some minor finishing work was done. No excessive vibrations or movements have been detected of the cables during the period. small vibrations are experienced a wind velocities between 5-12 m/sec and these occur at stable winds at right angle to the bridge. During full storm, vibrations will occur in the side span on the eastern side, as the predominant winds are westerly.

For information to drivers windsocks are located at the bridge, but no arrangements for closing the bridge during high winds has been made. There are no problems with ice falling from pylons or cables.

### 10.3. Helgeland Bridge

The Helgeland bridge shown in *Figure 10.7* and *Figure 10.8* is part of a bridge and road project giving permanent connection to the town Sandnessjoen in 1991. The town is situated close to the Polar Circle.

This site is located on the coast in an area with very severe weather conditions. Extensive site instrumentation for wind measurements were made before the design period. Wind tunnel experiments were performed on sections as well as on a full model at the Boundary Layer Wind Tunnel Laboratory, University of Western Ontario, Canada.

Extensive Instrumentation was in operation during the construction period. Winds were varying considerably, calculated and measured movements showed good agreements [15], [16].

#### A. Bridge Superstructure

A typical cross section of the beam is shown in *Figure 10.9*. The required two lanes of traffic and a walkway resulted in a beam width of only 11.95 meters.

Partial prestress was chosen for the beam in both directions to enhance its ductility. Straight tendons in the edge beams are continuous over the full length of the bridge and are coupled in every construction joint. Additional continuity tendons are threaded into empty ducts after completion of the beam across the mid-quarter of the main span. Full-depth cross girders are provided at the cable anchor points. They contain the only transverse prestress. The reinforced 0.40 meters thick roadway slab spans 7.25 meters transversely and about 12.2 meters longitudinally.

#### B. Towers

Three basic tower shapes were investigated: H-, diamond-, and A-shapes. Concrete was the obvious choice of material for all shapes. The modified diamond shape shown in *Figure 10.10* was found most suitable, combining economy, aesthetics and structural behavior. The tower was designed with respect to lateral stiffness in this direction being provided by the backstays.

#### C. Cables

The bridge was designed with stay cables, 64 to 225 meters long with 67 to 231 wires diameter 7mm (St 1450/1659). Only shop fabricated cables were permitted in the bid documents in order to ascertain high quality and exact cable length. Fully galvanized

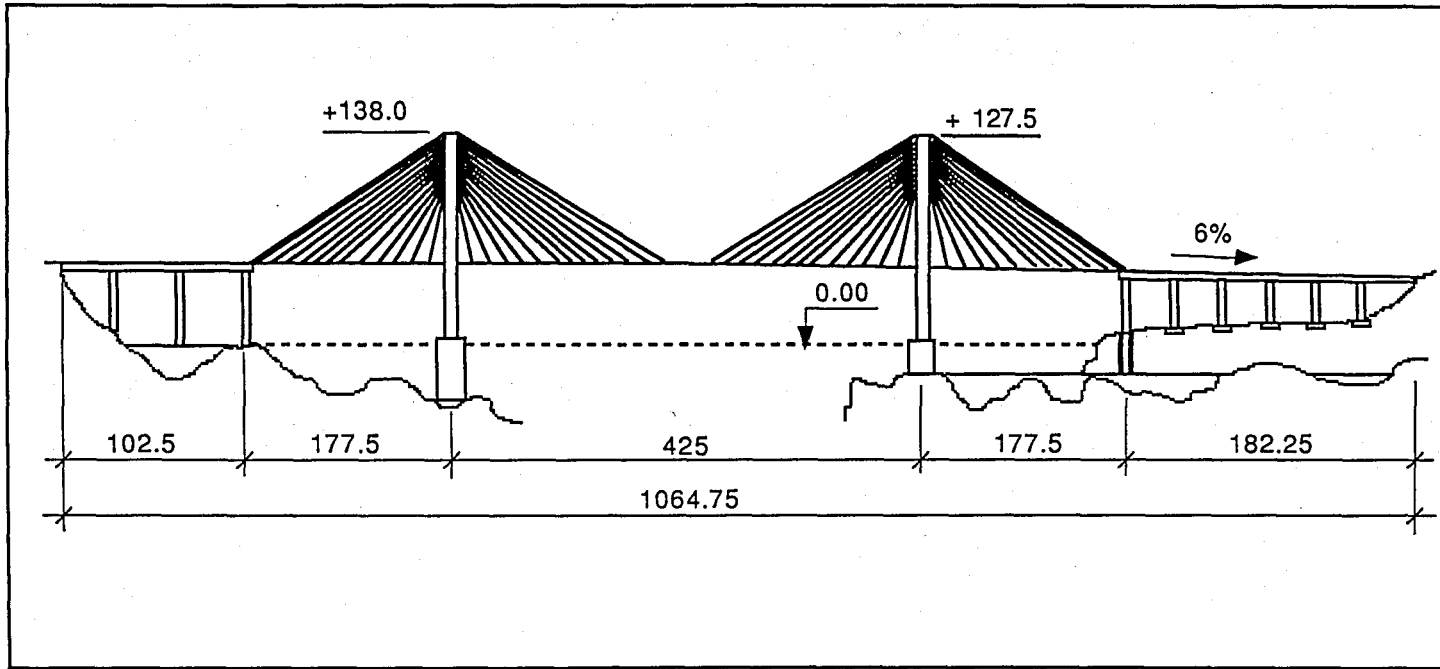
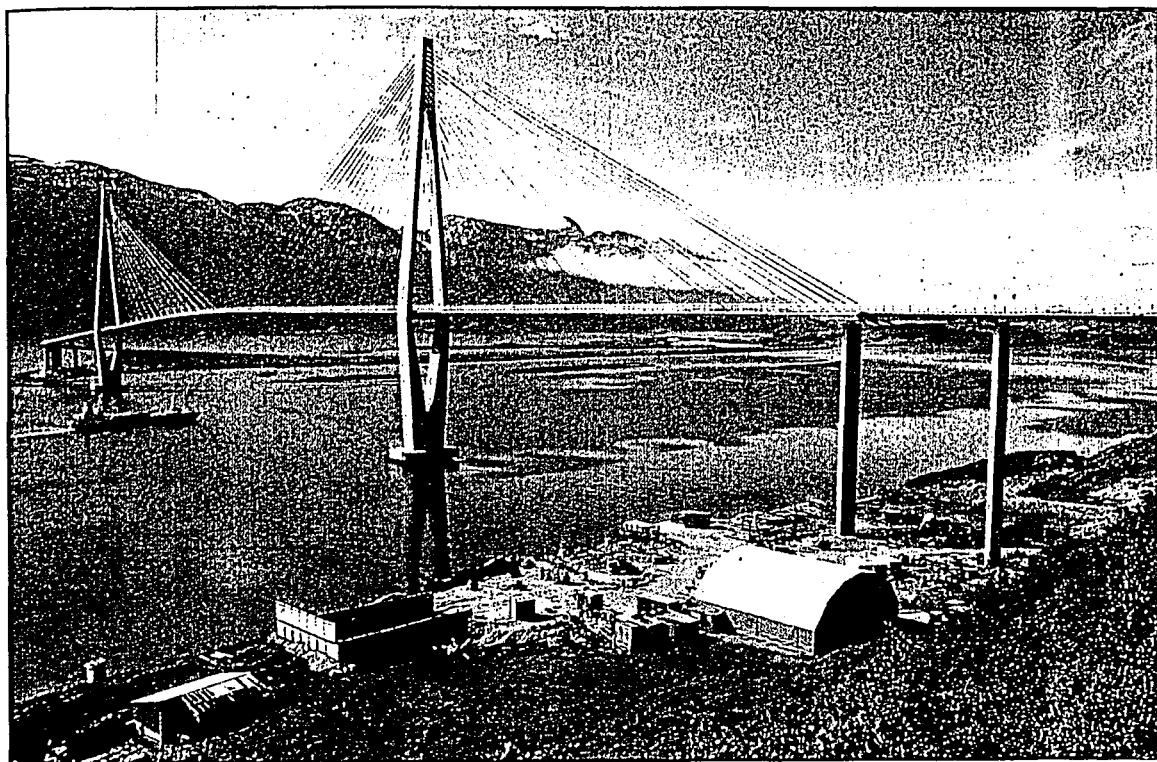

FIGURE 10.7. ELEVATION (in meters)



**FIGURE 10.8. HELGELAND BRIDGE, NORWAY** (Courtesy of P. Schoen, 1994)

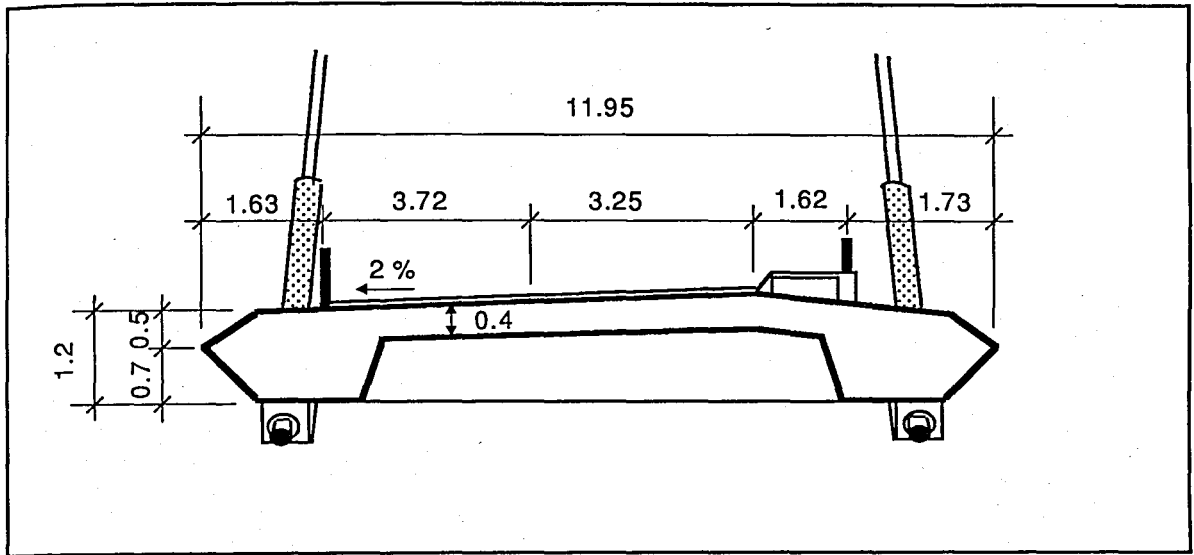

FIGURE 10.9. CROSS SECTION OF THE BRIDGE DECK (in meters)

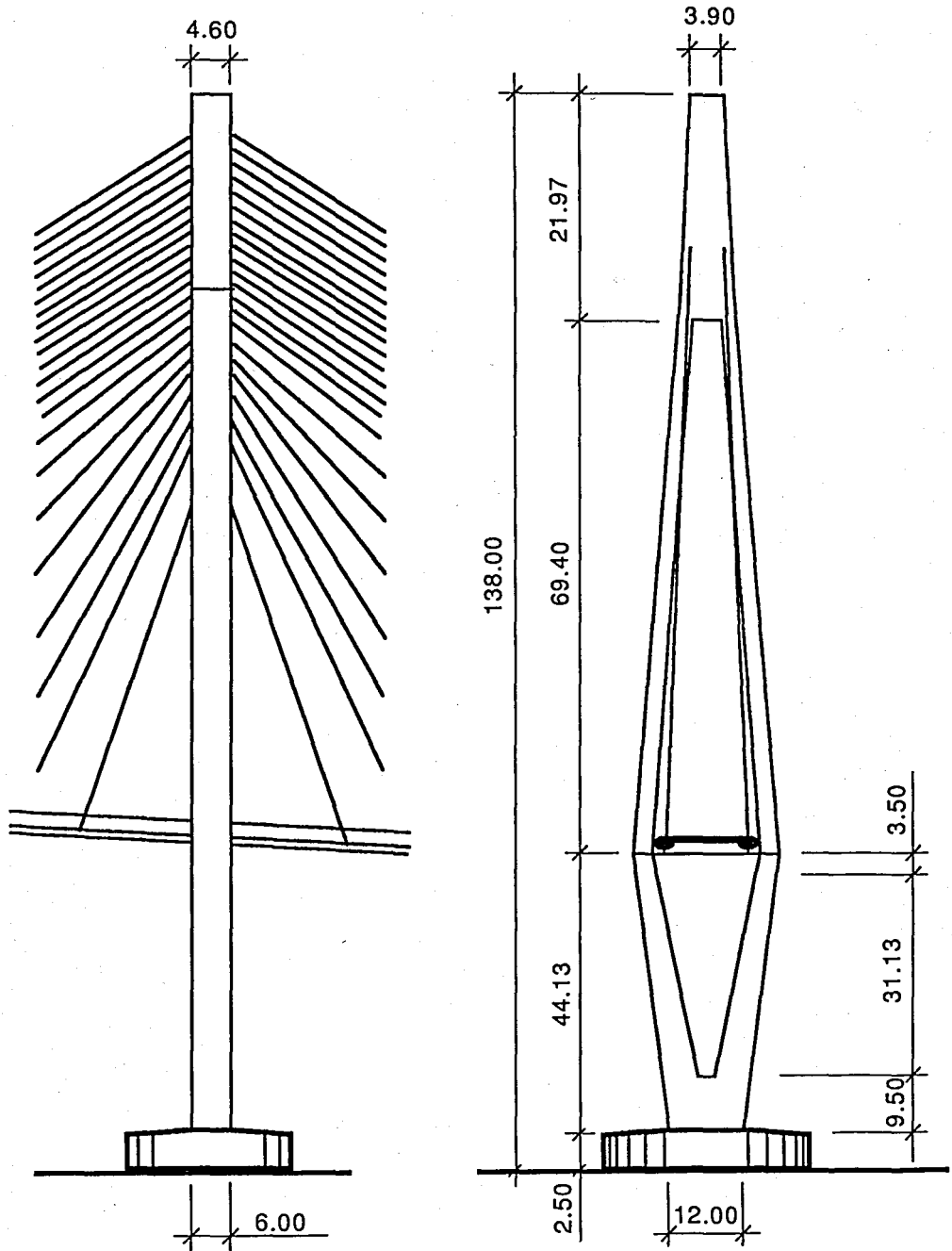

FIGURE 10.10. MAIN TOWER (in meters)

locked coil ropes with additional outside corrosion protection or parallel wire cables in PE-pipes with HiAm-anchorage were specified. The parallel wire cables were selected from the tendering.

#### D. Construction

The construction period was short, only about 2 years, and the contractor planned for continues work even during extreme weather conditions. In practice this included constructing pylons and side spans at the same time.

Slipform was used for pylons and side span columns as shown in *Figure 10.11* and *Figure 10.12*, these having very simple geometry presented no problems for slipform work. The slips with their complicated geometry and several directional changes did present serious problems. This work was done during winter at low temperatures and high winds. These conditions resulted in several scars that had to be repaired later. so far, these repairs seem to be satisfactory. With this experience in mind slip forming for such complicated pylons as these, would not have been approved today.

The bridge deck was cast using steel formwork with specially designed set of equipment. Two sets were used, one for each of the pylons. After some minor problems at the start, bridge deck was cast in even steps totaling 25,3 m in 10-15 days.

Depth to bedrock varied to -27 m with considerable depth of loose material in place. Most of the soil overlaying bedrock was removed by grabbing but blasting at the toe of the embankment was also used. Some slow deformation of the embankment occurred after completion of the bridge and a minor jacking operation will be necessary in future. This eventuality was provided for in the original design. The concrete was produced at the site or by a factory in Sandnessjoen.

Expect for some problems in early stages, concrete strengths were satisfactory. Air-entraining agents were not used for C65, this to ensure more even concrete strengths. The biggest problem during the whole construction period was the weather conditions. Wind characteristics were registered as hourly average and with these as basis, wind characteristics for 24 hours duration was determined. Examples of these may be seen in the *Table 10.1*.

The highest average winds per. hour was 30 m/sec, several gusts of wind above 35 m/sec were registered. In spite of the very difficult climatic conditions, no serious accidents to personal occurred.

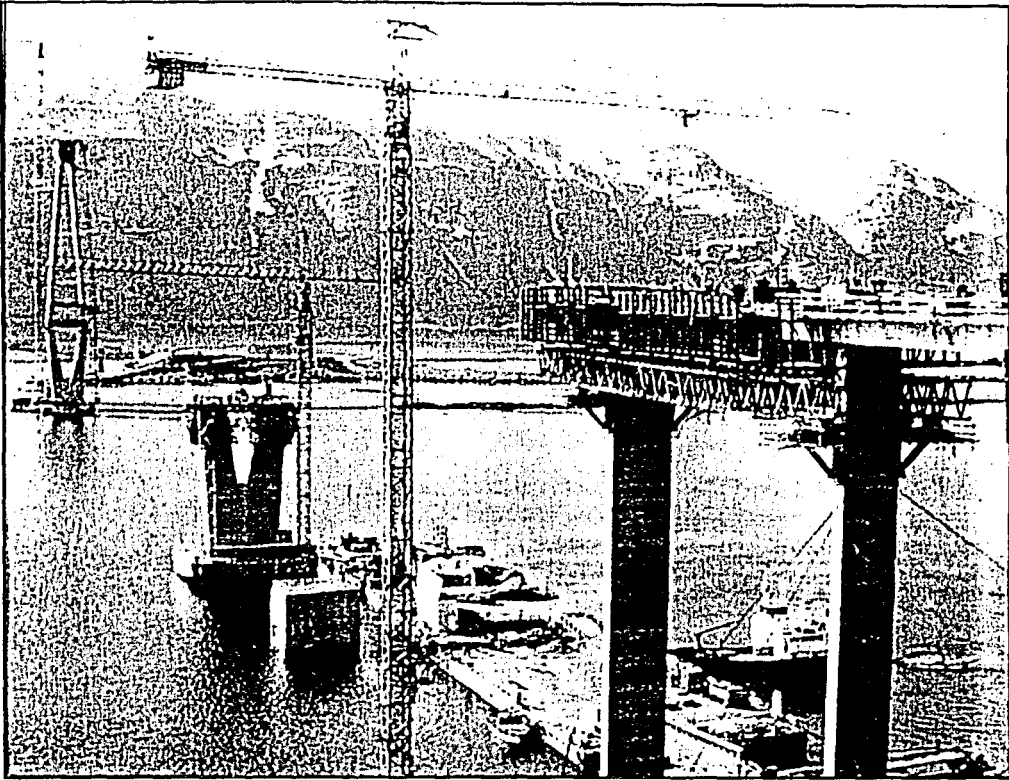

**FIGURE 10.11. SLIPFORM USED FOR SIDE SPANS**  
(Courtesy of S. Vegvesen, 1994)

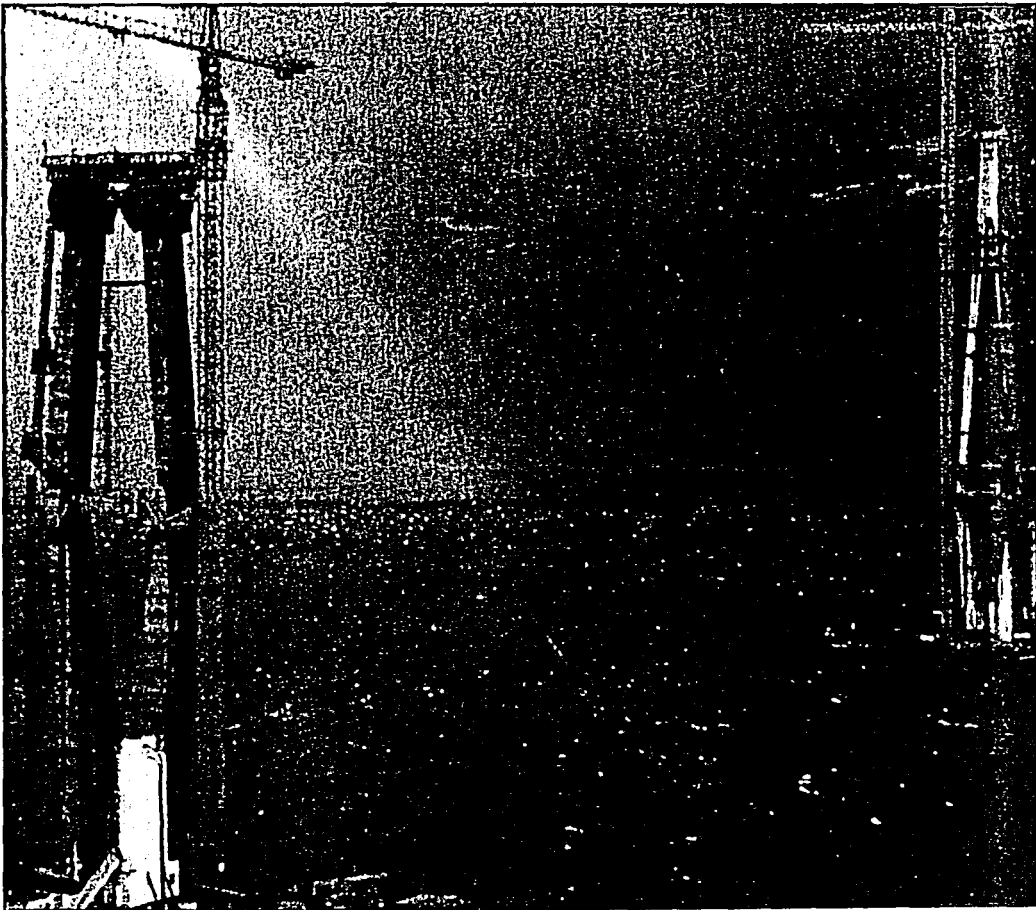

**FIGURE 10.12. SLIPFORM USED FOR PYLONS** (Courtesy of S. Vegvesen, 1994)

## E. Cost and Financing

The total cost of bridge and adjacent road-construction was USD 49 mill(1993). A toll road company has 25%, the remaining is financed by ordinary State Road funds. Time to cover the 25% will be about 15 years, then the project is paid for in full. The cost of the bridge itself was USD 41 mill(1993), some minor finishing work included. This amounts to USD 41 mill per. m bridge, in comparison to large traditional cantilevered bridges, this is about 2,5 times as much.

## F. Finishing and Maintenance

During the construction period, large and violent movements of the cables were observed. These were stopped by temporary stiffening by ropes. After the bridge was opened to traffic, very large movements were experienced especially in the longest cables. Movements in the cables were not only dependent on wind but rainfall was also a contributing factor. Cross stiffening of cables was provided to stop the movements. this arrangement seem to work satisfactory. The system may be seen in *Figure 10.13*.

Noprene dampers were originally designed both at the fixing points at bridge deck level and for the pylons. These dampers were partly destroyed by violent cable movements, the PE sheeting of the cables was also damaged in places. The repair has been both difficult and expensive and has resulted in new design details at the fixing points of the cables. During 1992 and 1993 the cost of these repairs amount to USD 2 mill, these costs might have been avoided by choosing different design details from the start.

During the construction period at a certain amount of chlorides were registered, especially where concrete was exposed to the most severe conditions. as a preventive measure, silan/siloksan impregnation was applied below bridge deck level during the summer season of 1992.

After opening the bridge to traffic, only minor repairs have been necessary, such as painting patches on exposed steel and some improvements of the electrical equipment. the cost of these operations has been negligible.

## G. Traffic

There was considerable general discussion as to the traffic safety in crossing the bridge during high winds. Automatic wind warning system was therefore installed. at average wind velocities of 20 m/sec lasting more than 5 minutes, signs are switched on warning the road users. If wind velocities increase to 30 m/sec in a five minute period, the

TABLE 10.1. WIND CHARACTERISTICS

|                          | 15-20<br>m/sec | >20<br>m/sec |
|--------------------------|----------------|--------------|
| Sept.1989-<br>April 1990 | 37 days        | 18 days      |
| Sept.1990-<br>April 1991 | 29 days        | 18 days      |

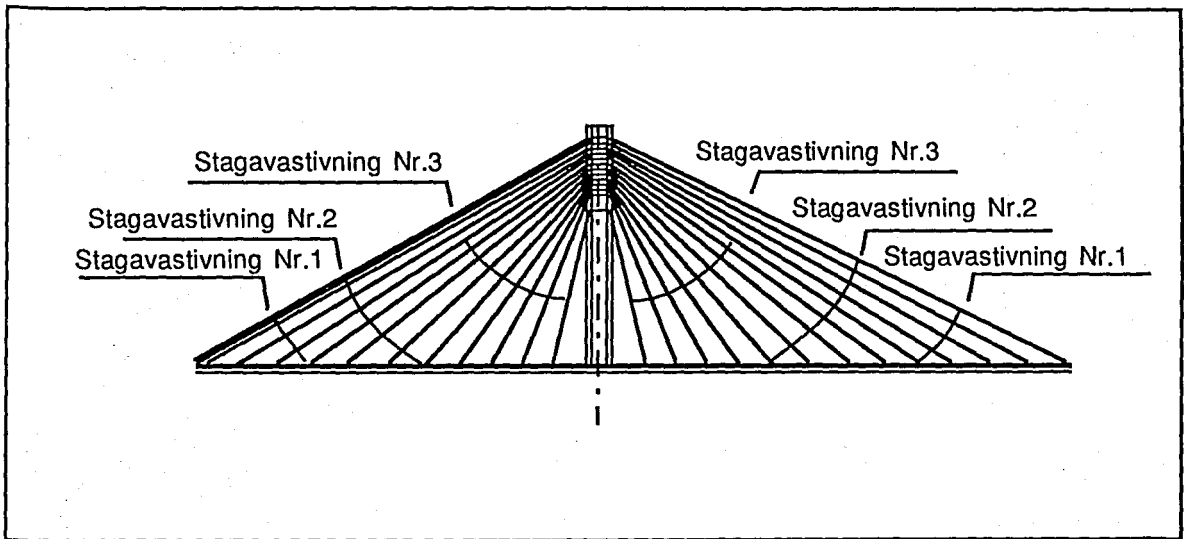

FIGURE 10.13. CROSS STIFFENING OF CABLES

road is closed by red-light and barriers are lowered. So far the problems caused by wind have been relatively small, only a few occasions the bridge has been closed for short periods.

Under certain climatic conditions ice forms high up on the surface of the pylons. Later increase in temperature causes the ice to fall down, sometimes on to the bridge deck. This is a potentially dangerous situation for road users and two incidents have been registered of cars being hit. If this should turn out to be a continues problem, corrective measures will have to be taken. The cables has so far been free for ice, one reason may be the very smooth surface of the PE sheeting.

#### 10.4. Conclusions

Skarnsundet and Helgeland bridges have been in service for three years. Technical data of each bridge is indicated in *Table 10.2*. The experience from construction and operation may be summarized as follows [15]:

- (a) Construction of large cable stayed bridges in very severe climatic conditions is a feasible proposition. The whole operation is a great challenge to the owner, consultants an particularly to the contractor.
- (b) Both bridges have been received well by the public, and the Skarnsundet bridge has been given the Norwegian Concrete Society's Award for outstanding use of concrete.
- (c) Pylons and columns for the side span have been produced by slipforming. Experience with this system is not good for this conditions and complexities of structures.
- (d) The two bridges have different types of cable systems, the system of Skarnsundet has given no problems. The system for Helgeland bridge has required considerable repair and partly redesign at considerable cost. This system is judged to be unsatisfactory, at least for this particular site.
- (e) Both bridges have been extensively instrumented.
- (f) The traffic has been as predicted and financing by toll as excepted.

TABLE 10.2. TECHNICAL DATA

|   | SKARNSUNDET BRIDGE                  | HELGELAND BRIDGE   |
|---|-------------------------------------|--|
| <b>Main measurements :</b>              |                                     |  |
| Main span                               | 530 m                               | 425 m  |
| Total length                            | 1010 m                              | 1065 m   |
| Total width                             | 13.0 m                              | 11.95 m  |
| Maximum pylon height<br>above sea level | 152 m                               | 138 m  |
| Maximum depth of foundation             | -27 m                               | -30 m  |
| Ships sailing restrictions              | 45 x 200 m                          | 43.5 X 200 m   |
| <b>Loads :</b>                          |                                     |  |
| Wind, finished bridge                   | 38.5 m/s                            | 50 m/s   |
| Wind, construction phase                | 33.5 m/s                            | 45 m/s   |
| Turbulence, horizontal                  | 15 %                                | 20 %   |
| Turbulence, vertical                    | 10 %                                | 12 %   |
| Earth quake, (100 yrs)                  | 0.5 m/s <sup>2</sup>                | 0.5 m/s <sup>2</sup>   |
| Earth quake, (10.000 yrs)               | 1.8 m/s <sup>2</sup>                | 1.8 m/s <sup>2</sup>   |
| <b>Concrete :</b>                       |                                     |  |
| Foundations                             | C45                                 | C35  |
| Viaducts and coloumns                   | C45                                 | C45  |
| Pylons                                  | C45                                 | C65  |
| Main and side-span                      | C60/C45                             | C65  |
| C25/C35                                 | 1600 m <sup>3</sup>                 | 11300 m <sup>3</sup>   |
| C45                                     | 15300 m <sup>3</sup>                | 5700 m <sup>3</sup>  |
| C60/C65                                 | 2700 m <sup>3</sup>                 | 12600 m <sup>3</sup>   |
| Total quantity of concrete              | 19600 m <sup>3</sup>                | 29600 m <sup>3</sup>   |
| Reinforcement steel Ks50                | 3600 tons                           | 3000 tons  |
| Formwork                                | 52000 m <sup>2</sup>                | 43000 m <sup>2</sup>   |
| <b>Cables :</b>                         |                                     |  |
| Number of                               | 208 pcs                             | 128 pcs  |
| Total weight                            | 1030 pcs                            | 745 pcs  |
| Diameter                                | 52-85 mm                            | 110-180 mm   |
| Lengths, min-max                        | 76-288 m                            | 63-225 m   |
| Type                                    | Closed, spiraled<br>(galvanized)    | Parallel $\phi$ 7 mm threads<br>(galvanized in PE-sheating)    |
| <b>Contractor :</b>                     | Aker Entreprenor/A/S/<br>Veidekekke | Aker Entreprenor/A/S/<br>Veidekekke                            |
| <b>Cable supplier</b>                   | Austria Draht GmbH                  | Stahlton AG  |
| <b>Consultant</b>                       | Johs. Holt A/S                      | Dr. Ing. A. Aas-Jakobsen A/S<br>Leonhard, Andra und<br>Partner |

## **11. CASE STUDY NO.2**

### **AKASHI KAIKYO SUSPENSION BRIDGE IN JAPAN**

#### **11.1. Introduction**

The Akashi Kaikyo bridge over the Akashi strait will link Honshu, the main island of Japan, with Awaji island. *Figure 11.1* shows the general view of the Akashi Kaikyo Bridge [17]. The bridge with a main span of 1990 meters, has the longest bridge span in the world. It is a 3-span, 2-hinged stiffening truss suspension bridge which carries dual three-lane roadways. The construction of the bridge began in May 1988 by the Honshu-Shikoku Bridge Authority, and is to be completed in 1998.

#### **11.2. Conditions of Design**

The width of the Akashi strait is about 4 km, and the maximum water depth along the bridge's route is approximately 110 meters. The strait is one of the most important maritime transportation routes which about 1400 vessels per day navigate. The sea road with a clear opening of 1500 meters and a clearance height of 65 meters above water level is set over a total extension of 7 km in this strait under the Maritime Traffic Safety Law of Japan. Because of this and geological conditions, this bridge needs a total length of 3910 meters that includes a center span of 1990 meters.

The maximum speed of tidal current is approximately 4.0 m/sec. The strait is difficult to work on, and various experimental works were carried out to design the shape of underwater foundations and to develop the working method. Design Standards are as follows [17]:

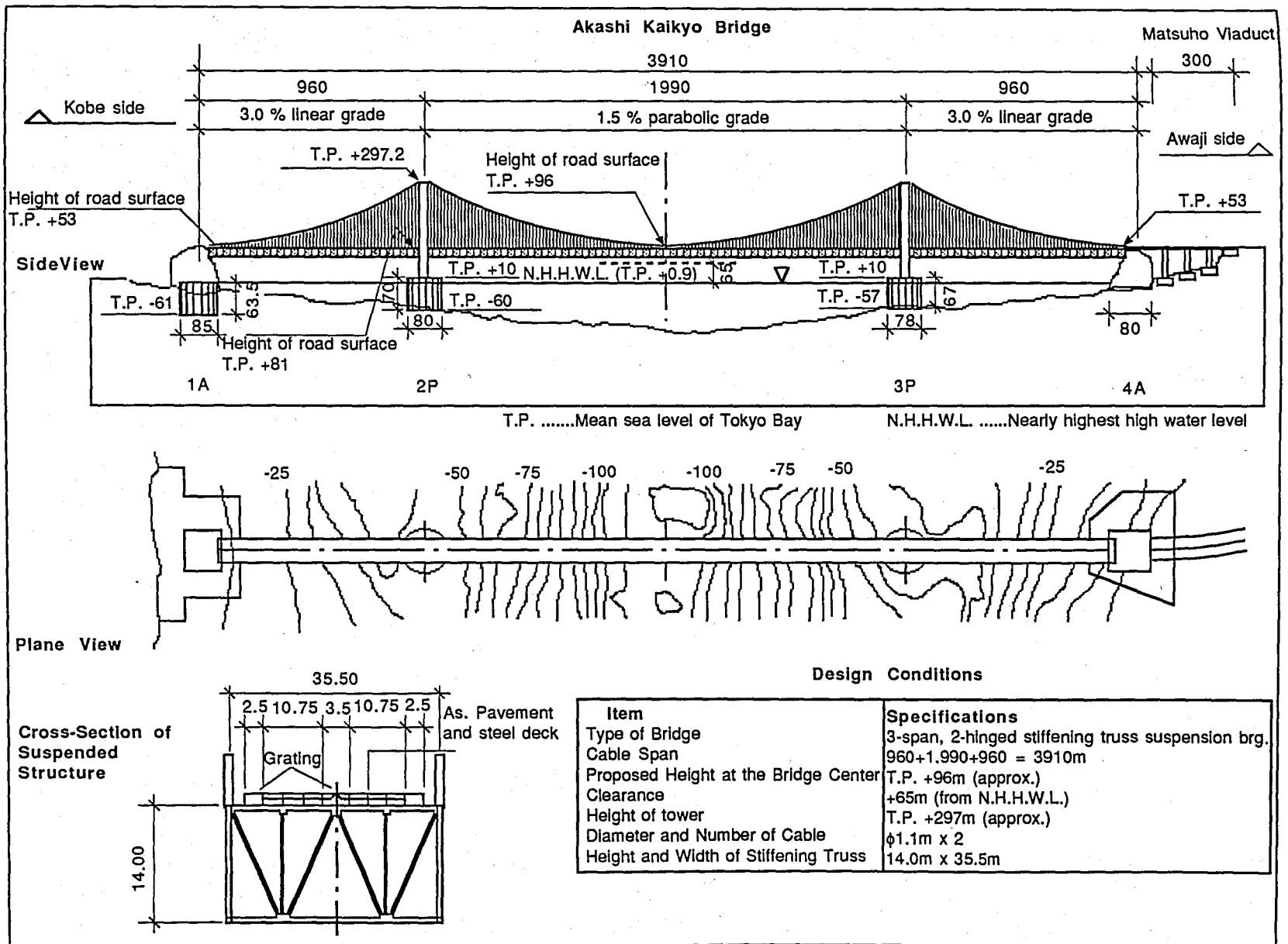

FIGURE 11.1. GENERAL VIEW (in meters)

(a) Dead Load.    Truss      29.54 tf/m  
                         Cables     14.25 tf/m

(b) Live Load.    TL-20 & TT-43

(c) Temperature.    $-10^{\circ}\text{C} \approx +50^{\circ}$

(d) A basic wind speed is 46 m/sec (return period is expected to be 150 years) at 10 meters above sea level, which corresponds to 59.8 m/s at deck level. The wind speed was after statistically processing the wind speed records during 20 years at the site.

(e) The bridge is designed to withstand of the earthquakes with a magnitude of 8.5 on the Richter scale, which is expected to occur about 150 km away from the site.

### 11.3. Construction of the Main Pier Foundations

*Figure 11.2* shows the general view of the main pier foundation. Natural conditions of the strait are very hard, and the main piers were constructed by “the Laying-down caisson method”. It reduces the work on the sea and increases the safety and reliability of the construction. Its work procedure is divided into the following stages [17], [18]:

- (a) excavating the seabed;
- (b) towing the steel caisson;
- (c) setting the steel caisson;
- (d) protection from scouring around the steel caisson;
- (e) casting the concrete.

Three types of grabs for the excavation were used depending on geological conditions and the stage of work. The buoyancy of the caisson is made by a double-wall structure. Those caissons were towed to the site and set on the pre-excavated seabed. computer graphic and data processing systems in real time were developed to control the setting. Therefore, setting works of the caissons were finished in high accuracy with error on the plane within 50 mm. To prevent scouring the ground around the caisson, the filter units were installed. After that, a concrete plant barge and a materials were moored at the caisson and underwater concrete was cast. The concrete has high resistance to the separation of the concrete in the water.

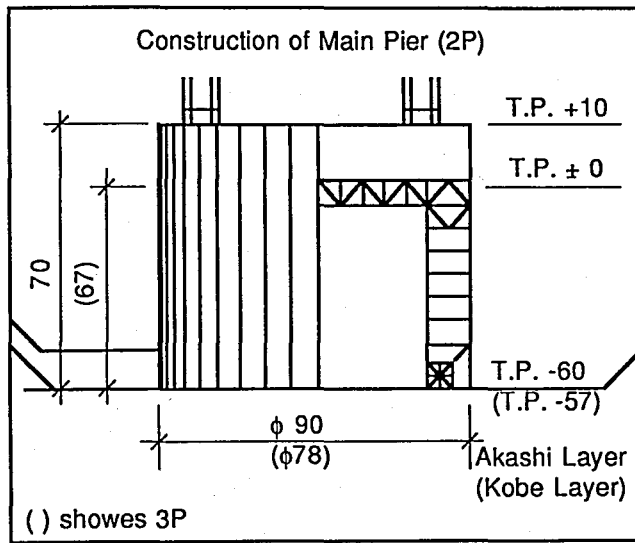

**FIGURE 11.2. MAIN PIER FOUNDATION (In meters)**

## 11.4. Outline of the Anchorage

As shown in *Figure 11.3*, the anchorages are 63 meters wide and 84 meters long. Due to geological conditions, 1A foundation had to be embedded into 61 meters below sea level and the circular slurry wall 85 meters diameter and 2.2 meters thickness was utilized as a retaining wall.

## 11.5. Design and Erection of Main Towers

The main tower is made of steel. The height of the tower is 282.8 meters, and the shaft has a cruciform cross section as shown in *Figure 11.4*. The tower shaft is longitudinally divided into 30 tiers, which is also separated into 3 cells except for the bottom tier. Those blocks were fabricated accurately in factories.

As illustrated in *Figure 11.5* the tower was lifted up with a self-supporting type of crane which can lift up a block of 160 ton and raise itself. The natural frequency of the tower is even low after completion of the whole bridge. Therefore, wind tunnel tests were carried out to determine the behavior of the towers in wind. As a result of various studies, it was confirmed the amplitude of vibration below an allowable level, TMDs (tuned-mass dampers) shown in *Figure 11.6* were installed in the tower shafts.

## 11.6. Erection of Cables

*Figure 11.7* shows the cable section. Each cable which is composed of 290 strands is to be erected with "the Prefabricated Strand Method." The strand is composed of 127 galvanized steel wires with a tensile strength of  $180 \text{ kgf/mm}^2$ . In Japan, wire having tensile strength of  $160 \text{ kgf/mm}^2$  has been widely used since Kanmon Bridge. By the additional tensile strength of  $20 \text{ kgf/mm}^2$ , the number of cables can be reduced from 4 to 2 in total.

*Figure 11.8* shows cable erection procedure. As shown in it, a helicopter was used in spanning of the pilot rope. The main cables are to be erected with "the Prefabricated Strand Method." The method is to install the strands which were previously made at the shop. It has an advantage in on-site labor-saving. The strand used for this bridge has an overall length as long as 4100 meters and weighs 90 tf as weight, and the diameter of the cable is about 1.1 meters.

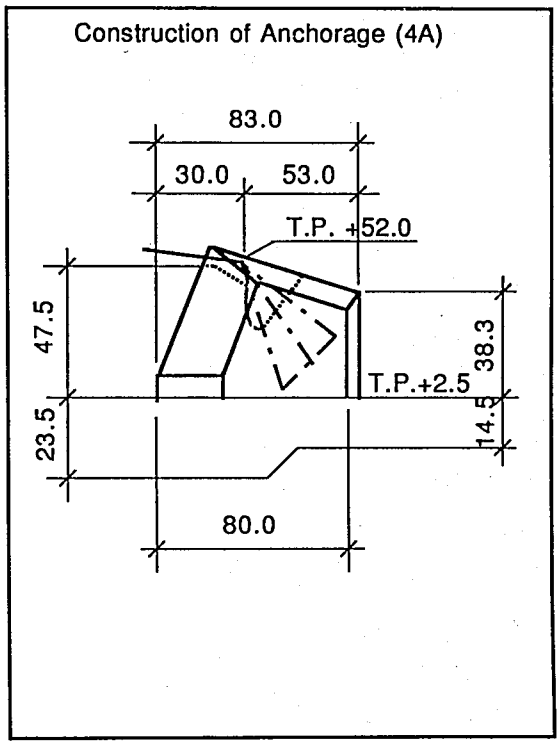
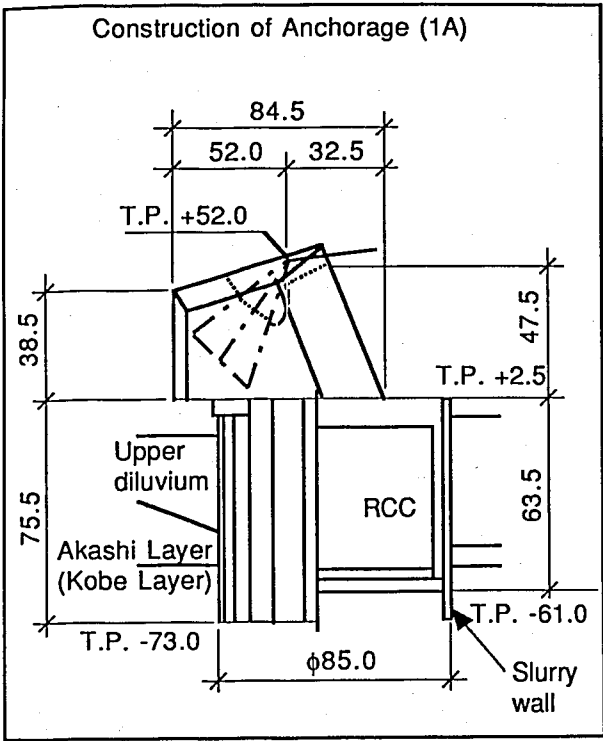

**FIGURE 11.3. ANCHORAGE (In meters)**

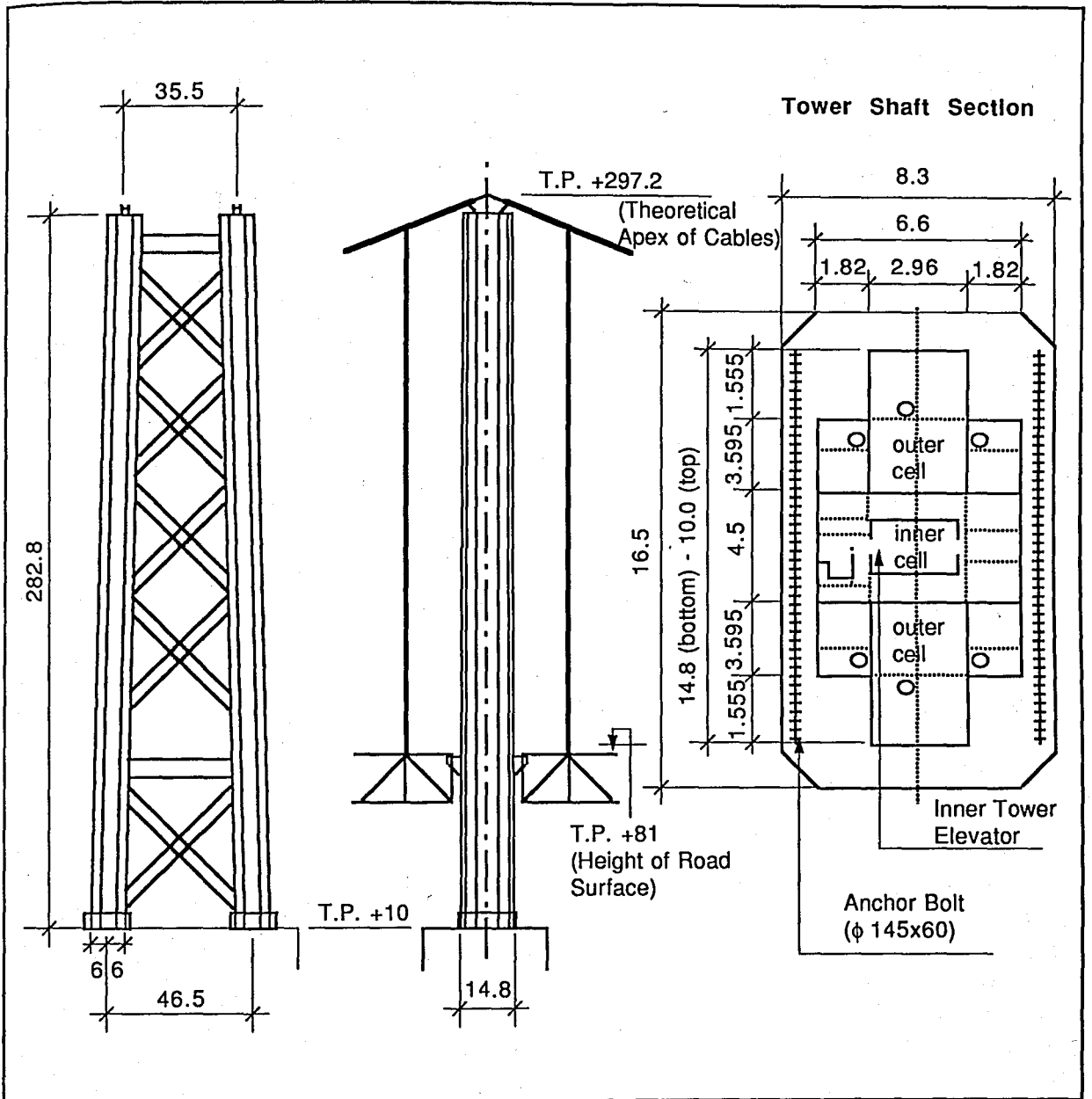
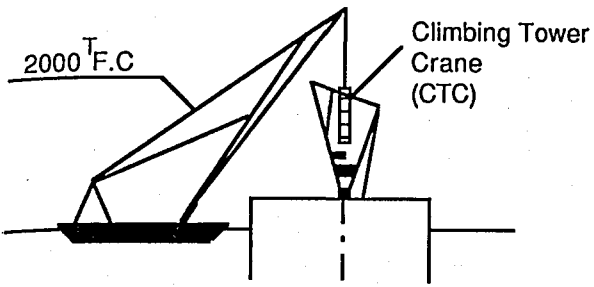
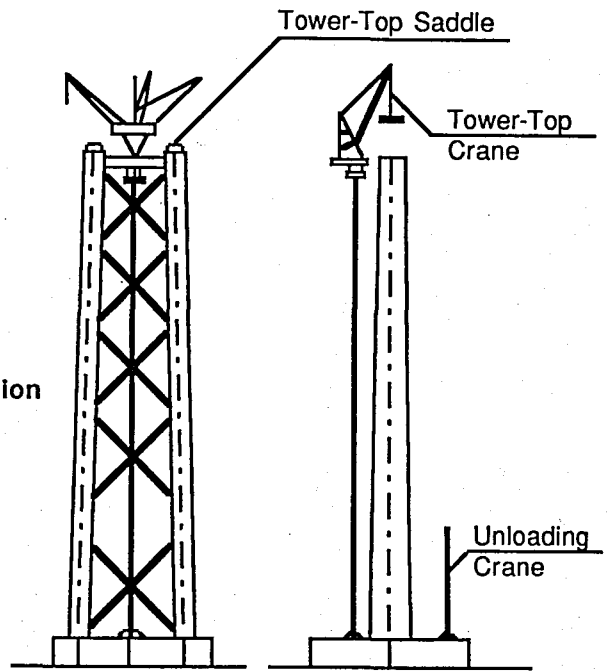

FIGURE 11.4. MAIN TOWER (In meters)

1. Unloading Crane, Pier, and CTC Installation



4. Tower-Top Saddle / Tower-Top Crane Installation



2. Base Plate/First Block of Tower Installation

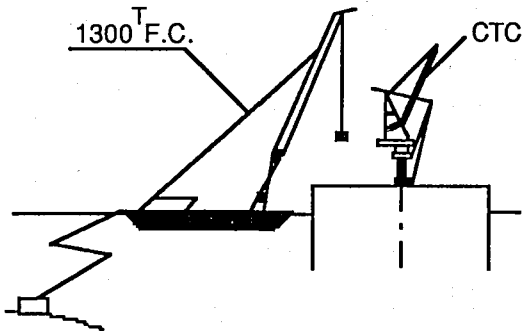

3. tower Block Erection (8th Stage Erection)

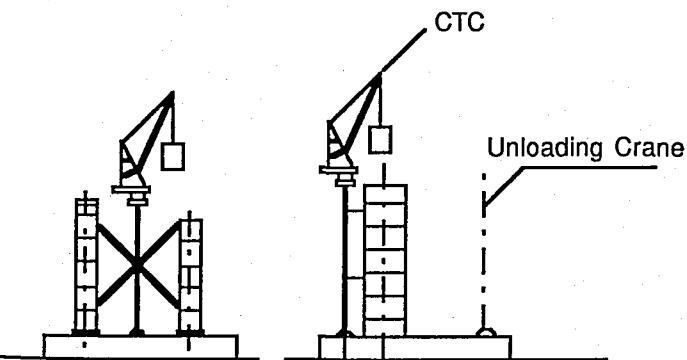

FIGURE 11.5. TOWER ERECTION PROCEDURE

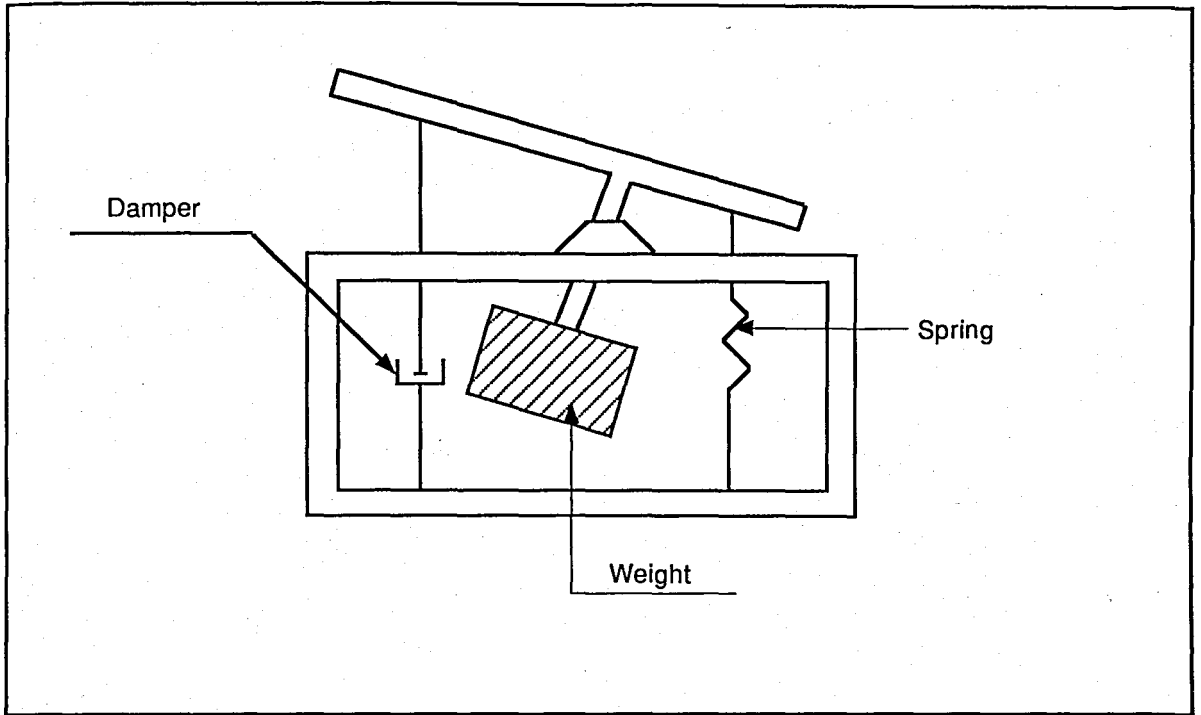
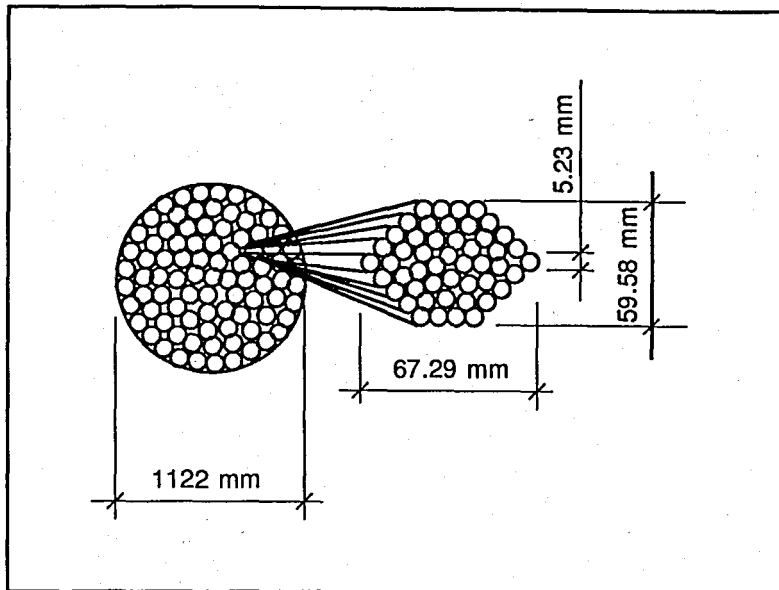

FIGURE 11.6. TUNED-MASS DAMPER



|                            |                  |   |
|----------------------------|------------------|---|
| c<br>a<br>b<br>l<br>e      | diameter         | 112cm   |
|                            | maximum tension  | approx. 60.000 ton/cable (600 MN)                                 |
|                            | structure        | 127 wires/strand x 290 strands/cable = 36.830 wires/cable         |
|                            | length           | 4085m   |
| s<br>t<br>r<br>a<br>n<br>d | wire diameter    | $\phi$ 5.23mm   |
|                            | allowable stress | 82kgf/mm (=837MPa)  |
|                            | dimension        | 68mm x 60mm   |
|                            | length           | 4071 - 4074m  |
|                            | total length     | $4.07\text{km} \times 127 \times 290 \times 2 = 300.035\text{km}$ |

FIGURE 11.7. CABLE SECTION

1. Spray Saddle Installation

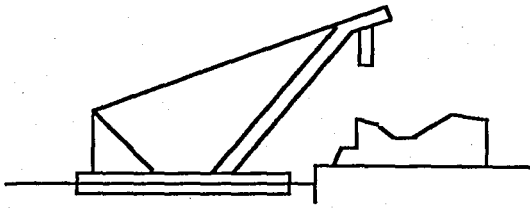

2. Pilot rope Spanning

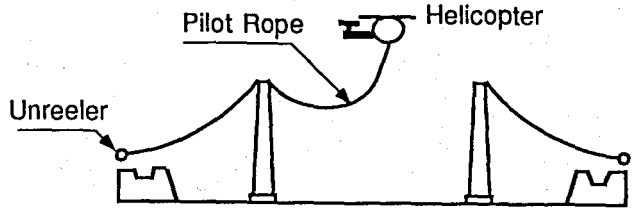

3. Catwalk Rope Erection

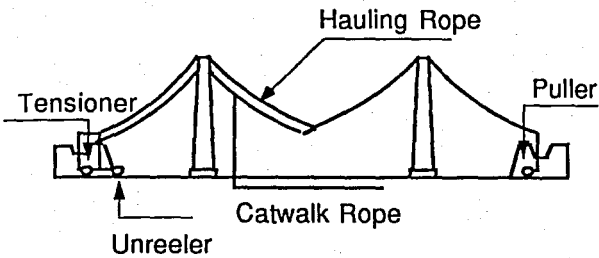

4. Catwalk Floor System

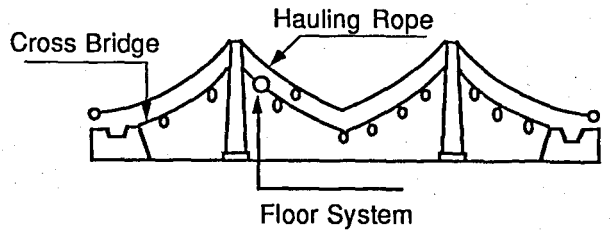

5. Strand Erection

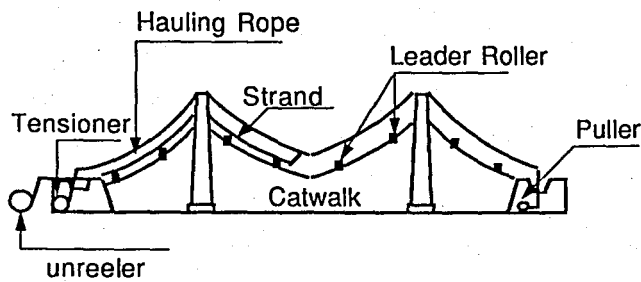

6. Squeeze, Cable band and hanger rope

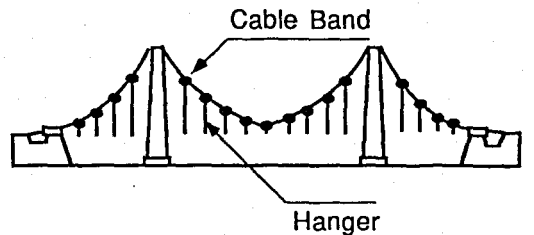

FIGURE 11.8. CABLE ERECTION PROCEDURE

## 11.7. Design and Erection of Suspended Structure

The stiffening truss, which has a height of 14 meters and a width of 35.5 meters, is fabricated by 20 steel bridge fabricators. It is very important for a long-span suspension bridge to reduce the weight of stiffening girder, quenched and tempered high strength steel (tensile strength 80 kgf/mm<sup>2</sup>) is therefore to be used. The truss girder is adopted by the following reasons:

- (a) Structural modification to cope with aerodynamic stability is easy.
- (b) Occupation of the sea area during erection is small by using "Erection with Plane Block Method."

The wind effects are a major importance for this bridge. Wind tunnel tests were therefore carried out at Public works Research Institute at Tsukuba city, on the 3-dimensional elastic model of the entire bridge (1:100 scale model) to establish the aerodynamic stability. These tests are summarized as follows [17]:

- (a) effects of maintenance passages;

The position of maintenance passages affect flutter resistance of the girder, and it was found out that the maintenance passages on both the upper and lower decks can improve the flutter resistance.

- (b) effects of curb configuration;

Curbs at the both side of road deck worsen the flutter instability of truss girder, and they are removed.

- (c) effects of stabilizer.

A vertical plate-like stabilizer under the road deck at the center of the road way raises the critical wind speed of coupled flutter effectively, and it is installed in the center span.

The stiffening truss will be erected by "Erection with Plane Block Method." This method does not occupy the sea surface where many ships come and go. By this method, the panels are carried with barges from factories to main piers or anchorages, then are lifted and carried to the erection point on the bridge as shown in *Figure 11.9*.

## 11.8. Coating for Corrosive Environment

This bridge is constructed over the strait in a severe corrosive environment. Therefore, it is necessary to keep the bridge in a good condition by employing a suitable countermeasure to protect the structure from corrosion. Fluoropolymer paint was used, for corrosion which was recently developed and excels in durability and long-term luster.

**STEP 1 Stiffening Girder Erection for the Tower Part**

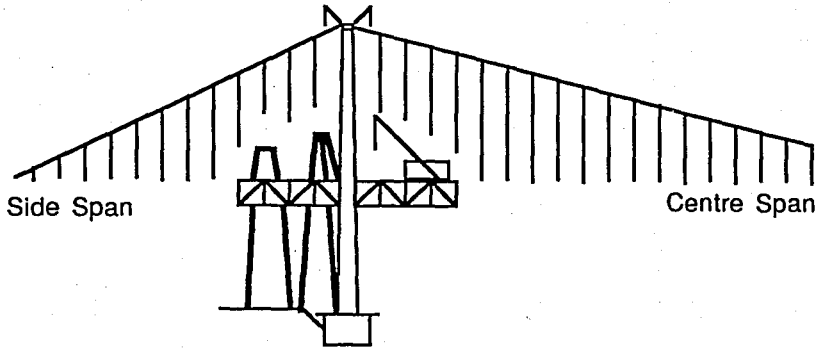

**STEP 2 First Step for Incremental Erection (Installation of Sliding Safety Net)**

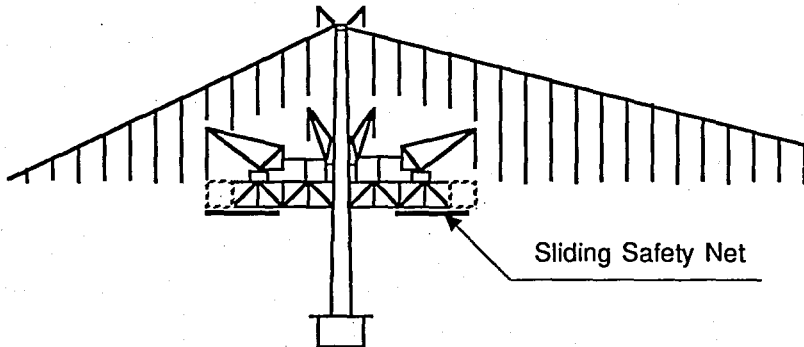

**STEP 3 Incremental Erection**

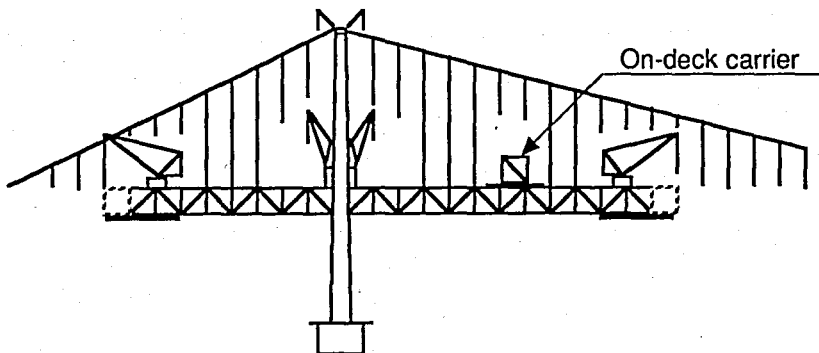

**STEP 4 Final Girder Erection**

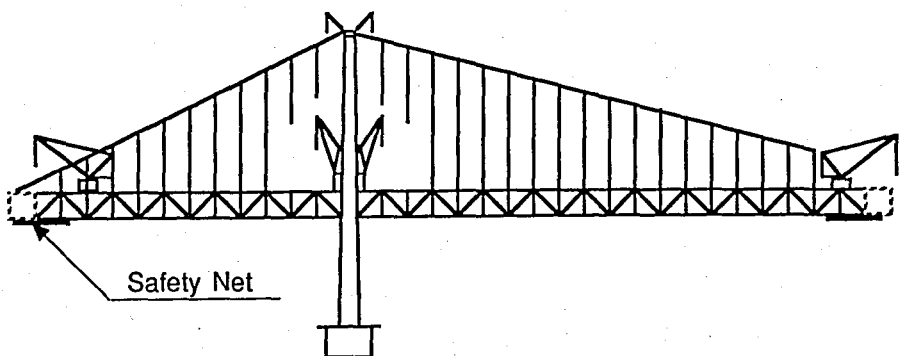

**FIGURE 11.9. STIFFENING GIRDER ERECTION**

## 12. CASE STUDY NO.3

### ***ASKOY SUSPENSION BRIDGE IN NORWAY***

#### 12.1. Introduction

The bridge shown in *Figure 12.1* and *Figure 12.2*, is located just outside the city of Bergen on the western coast of Norway, where it links the island of Askoy with the mainland [19], [20]. The bridge, completed in 1992, has a suspended span, 850 meters long, which presently ranks as the longest bridge span in Scandinavia. Particularly notable is also the great slenderness of the suspended span, defined by a length to width ratio of  $L/B = 54.8$ .

#### 12.2. Bridge Geometry - General

The bridge has a total length of 1056.7 meters including viaducts of 173.0 and 33.7 meters to each side of the suspended span. the viaducts are traditional prestressed concrete one cell box girders [19].

At present the bridge has 2 traffic lanes and 1 walkway. However, allowances were made for a future extension to 3 lanes and 2 walkways as illustrated in *Figure 12.3*, showing the cross section of the suspended span. the distance between the cable planes is 13.75 meters and the total section width is 15.52 meters. The bridge has a 200 meters wide navigation clearance of at least 62 meters height.

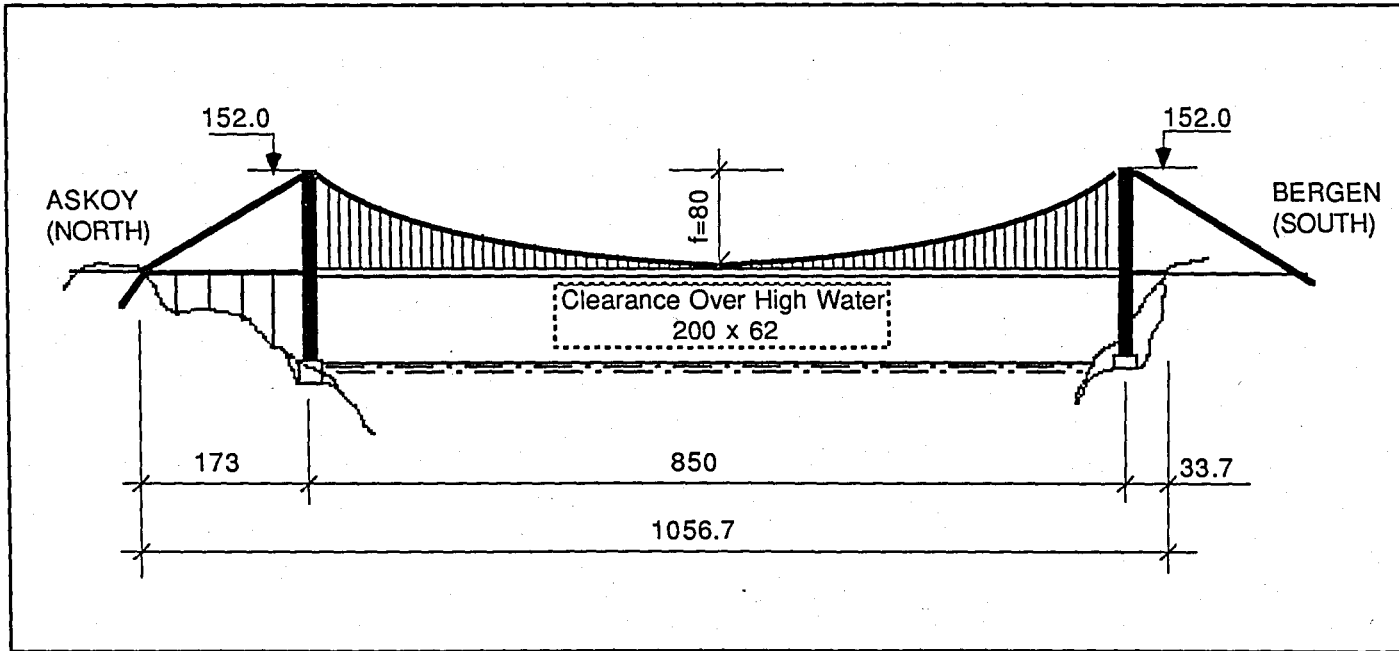
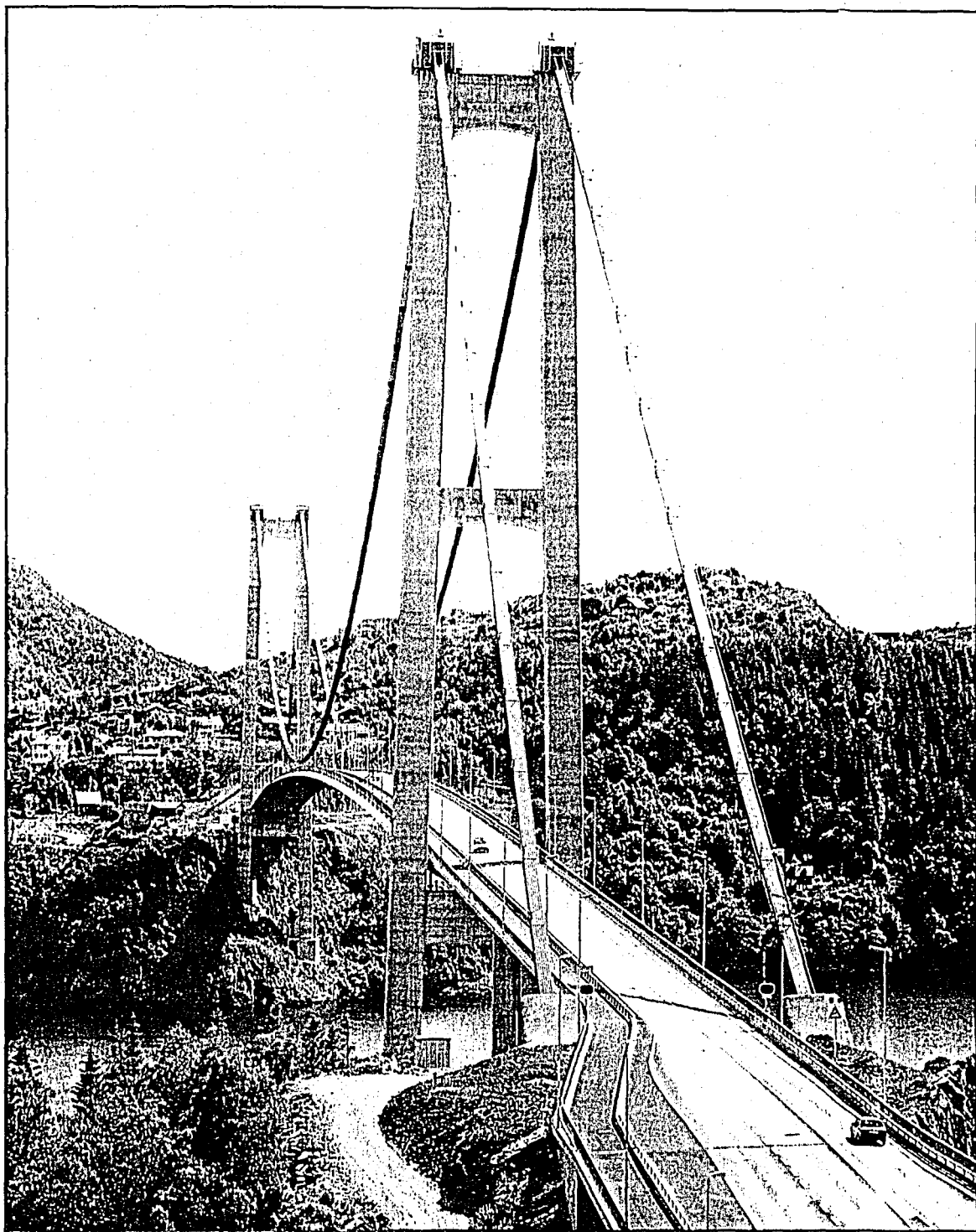

FIGURE 12.1. ELEVATION (in meters)



**FIGURE 12.2. ASKOY BRIDGE, NORWAY** (Courtesy of Monberg and Thorsen A/S, 1994)



### 12.3. Bridge Selection

The depth of the strait below the bridge is at the deepest about 320 meters, and the mountain plunges rather steeply into the sea at each side of the strait. The strait is the major seaway to Bergen, and the ship traffic in the strait is very heavy [19].

In the initial phase of the project, strait crossings by a rock tunnel below the sea bed and a submerged floating tube were considered in addition to the suspension bridge alternative. A cable stayed bridge was also briefly discussed, however, this alternative was ruled out to the topography on the site, giving very short side spans. For several reasons, technical and economical, the suspension bridge was chosen.

An important aspect in the decision making process was furthermore previous experience with suspension bridges, that have proven to be both economical and reliable structures. Several Norwegian contractors and steel workshops have wide experience with such bridges, and master all facets of a construction process.

### 12.4. Towers

The towers extending to a maximum elevation of +149,5 meters, are plane frame reinforced concrete structures with slightly inclined legs (transversely) and with 3 girders. North tower is shown in *Figure 12.4*. Legs and girders have rectangular hollow sections with rounded corners. The cross section of tower legs are constant along the whole length except for the out-of-plane section depth (parallel to the bridge axis), which varies from 7.5 to 4.5 meters, according to a second degree polynomial, for elevations between +2 and +70 meters. Above +70 meters, it stays constant [19].

The towers are founded on solid rock on full (solid) cross section foundations. The approximately 16 m high foundation pillars of the north tower are placed on the seabed. For the South tower, located in the steep and uneven mainland shoreline, the leg foundations are placed at widely different elevations (+30.9 and +12.4 meters, respectively) due to the hill topography. Specified concrete compression cube strength was 45 MPa for all concrete works.

#### A. Construction

Underwater concreting, which has found extensive use in Norway, was used in construction of the foundation pillars in sea. Formwork for each pillar, complete with reinforcement, was prefabricated and placed in one lift on a leveled seabed.

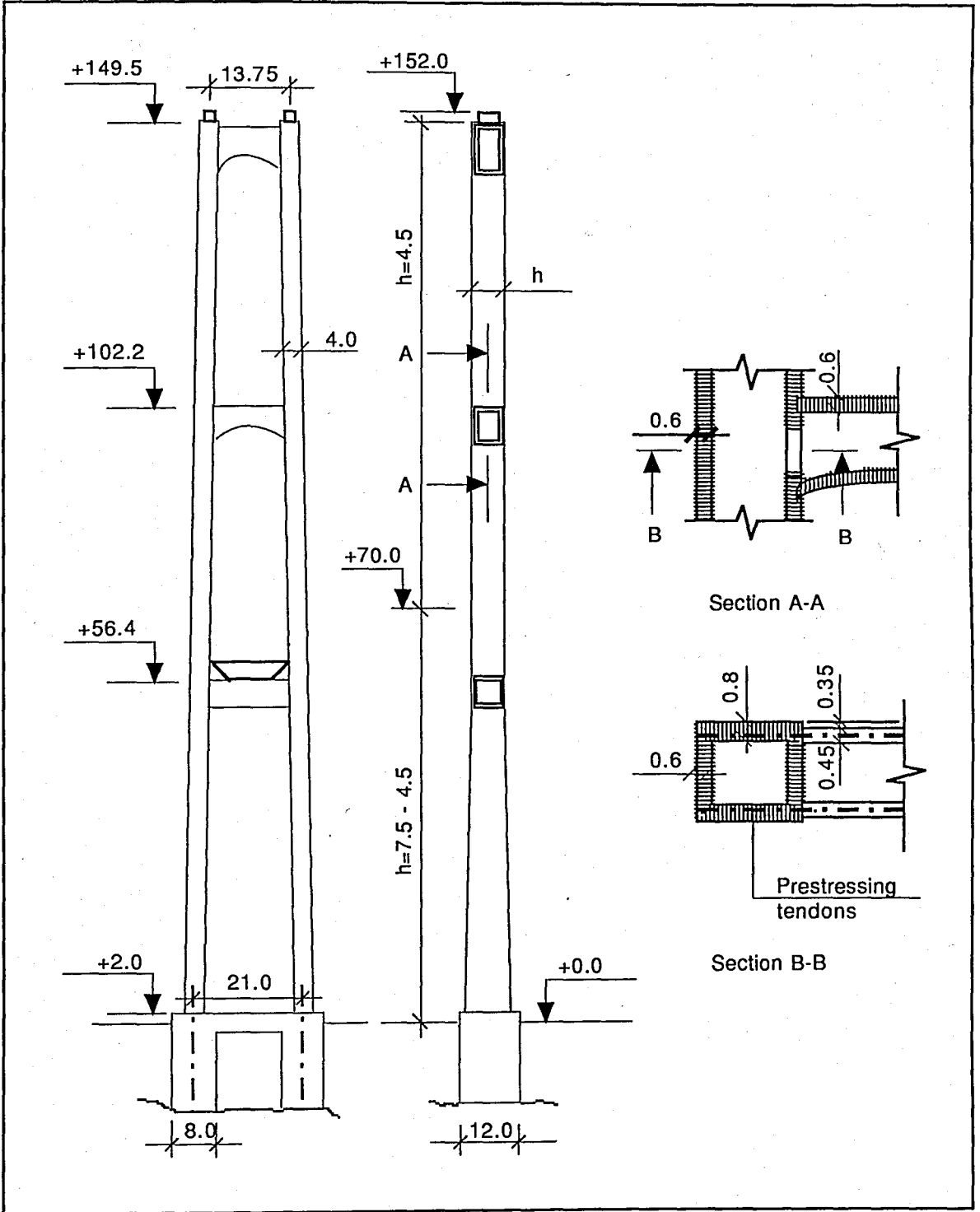

FIGURE 12.4. NORTH TOWER, ASKOY SIDE (in meters)

The legs of each tower were slipformed (simultaneously) in 3 stages. Full stops were made above each girder to allow concreting and hardening of the girder, and thus provide transverse tower bracing, prior to slipforming the next stage.

Towers were on the critical construction progress "line". A construction period of about 1 year was anticipated for each tower, including foundations. Work was partly staggered and partly overlapping on the two towers. They were completed according to schedule over a 1.1/2 years period (Dec. 1989 - May 1991), and a total cost of about USD 8.1 mill.

## B. Design Aspects

Considerable efforts were made to reach a reasonably optimal tower geometry and reinforcement magnitude. A number of alternatives were considered and evaluated before making the final choice, which was also influenced by architects' view points (e.g. the presence of an intermediate girder, curved bottom plates of the intermediate and top girders, etc.).

Efforts were also made to arrive at a construction-friendly design. Aspects simplifying slipforming were for instance:

- (a) constant wall thicknesses of tower legs;
- (b) essentially only prestressing steel (post tensioned) across leg/girder interfaces (*Figure 12.4, Section B-B*);
- (c) no horizontal diaphragms in tower legs at levels of top and bottom plates in girder (*Figure 12.4, Section A-A*), or elsewhere.

The last two items required particular attention being paid to conditions at the construction joints and to the detailing of ordinary reinforcement in both leg and girder regions adjacent to the leg/girder interfaces.

## 12.5. Saddles

The saddles, conforming to conventional Norwegian design, *Figure 12.5*, consists of curved 40 mm thick steel saddle plates (on which the cables are placed) supported on solid reinforced concrete blocks with a specified concrete cube strength of 55 Mpa.

During installation of the stiffening girder segments, the cable forces increase as the installation progress. As a consequence of the resulting elastic elongation and reduced sag of the side span cables, the tower tops are displaced towards the main span. In order to compensate for this displacement, a simple low friction bearing was

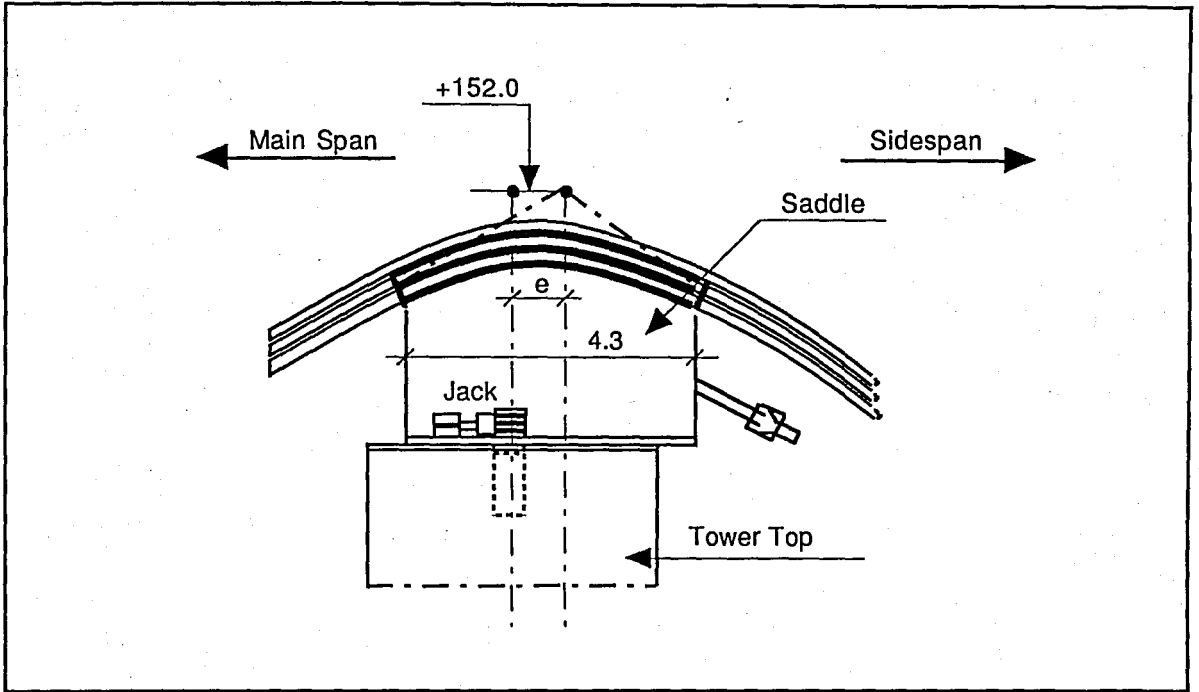

FIGURE 12.5. TOWER TOP WITH SADDLE (In meters)

provided at the saddle base. During the girder installation the saddles, relative to the tower tops, were gradually jacked towards the main span. Two 2500 kN hydraulic jacks, placed on each side of the saddle, were used to achieve the saddle displacements. With saddles in their final position, the bearing was "locked" and the jacks removed [19].

For instance, for the northern tower the saddles were initially placed with an eccentricity (towards the side span) of 750 mm. Following complete girder installation and application of all other dead loads in the main span (asphalt, railings etc.), the saddles were located centrally on the towers, and towers were in plumb.

Parts of the cables in the saddle region are not accessible to maintenance. For this reason, shelters with dehumidification systems maintaining the humidity below 40 per cent, are placed around the saddles.

Total costs of this saddle design, totaling about USD 0.5 mill, are believed to be rather modest compared to cast iron/steel saddles frequently adopted elsewhere.

## 12.6. Cable Anchorages

For all larger Norwegian suspension bridges, main cables have been anchored in rock. So also for the Askoy Bridge. Over the years rock anchorage system has developed that has proven to be both rather simple, reliable and economical. For the Askoy Bridge, the cost of anchorages is about 5.6 per cent of total bridge cost.

Major features of the anchorage system are depicted in *Figure 12.6*, and may be considered to consist of four main parts, namely [19]:

- (a) a splay chamber;
- (b) a reinforced concrete force transmission block;
- (c) a mass of rock sufficient to equilibrate the cable force;
- (d) an anchorage chamber.

In the splay chamber, the main cable, consisting of a bundle of 21 individual strands, is spread out and individual strand directions are deflected over a steel rocker splay saddle. The splay chamber is equipped with a dehumidification system in order to minimize maintenance requirements in this critical zone.

The individual strands are anchored to threaded steel bars cast into the force transmission block. These steel bars are further coupled to prestressed steel tendons passing through 25 meters long predrilled holes (165 mm diameter) in the rock, and anchored in the anchorage chamber.

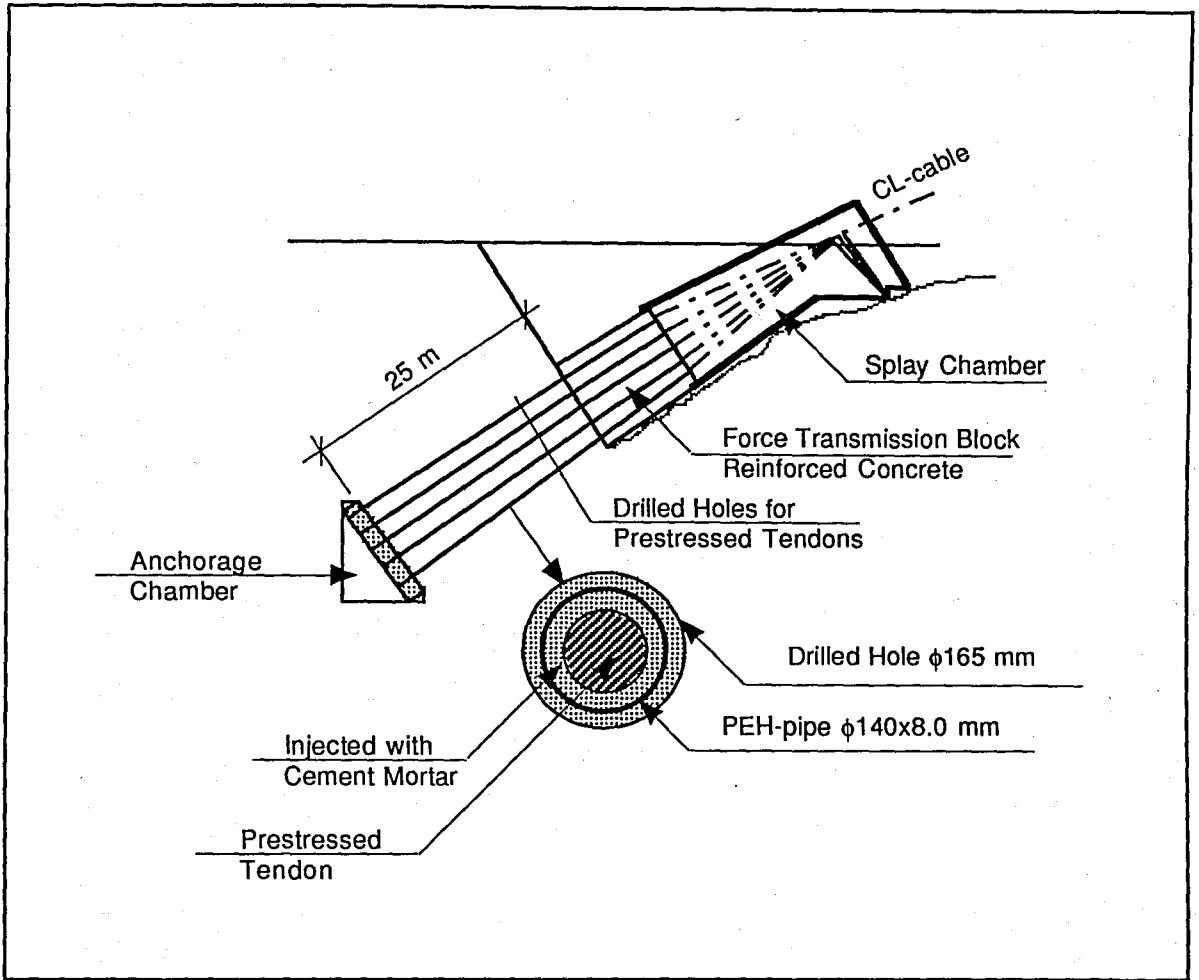

FIGURE 12.6. ANCHORAGE OF MAIN CABLES

In order to guard against corrosion, the prestressing tendons were placed in PEH - tubes that were grouted with cement mortar following prestressing operations.

## 12.7. Cables

Of the suspension span dead load, 25 per cent is due to the main cables, weighing 2450 kg/m. Costs including installation and surface treatment, of the cables with a total weight of 3000 tones, were about USD 15.8 mill. This amounts to about 25 per cent of total bridge cost.

The cables of a suspension bridge constitute the main carrying element, and it is impossible to replace a strand without incurring unacceptable costs. Thus, it is of the utmost importance that strands and elements connected to the cables, are designed such that they are not susceptible to corrosion and other damages. The cable system of the Askoy Bridge is briefly reviewed below [19].

### A. Cable System

Suspension bridge cables normally consists of:

- (a) bundles of parallel-wires, each with a diameter of 5-6 mm, or alternatively of
- (b) a number of prefabricated spiral strands, with diameter of 40 to 120 mm, that are placed in a bundle.

For technical as well as economical reasons, the latter alternative was chosen for the Askoy Bridge. Each of the two main cables consists of an "open bundle" of 21 locked-coil spiral strands placed in 3 layers, *Figure 12.7*. For inspection and maintenance reasons, the distance between the strands was chosen such that all strands can be reached by hand. During the final painting, a special paint-glove was used and the work proceeded smoothly.

Each individual strand is fully galvanized and has a diameter of 99 mm. It was prefabricated in its full length of about 1250 meters. Each strand weighs about 71 tones, and has a guaranteed breaking strength of 9060 kN.

### B. Cable Installation

Strands were delivered on steel drums, weighing 75 tones per unit. Prior to cable installation, "catwalks" consisting of a number of smaller wires anchored at each rock anchorage, were installed. The catwalk, with sag following the intended cable geometry, provided access below cable location. Installation of catwalk is shown in *Figure 12.8*.

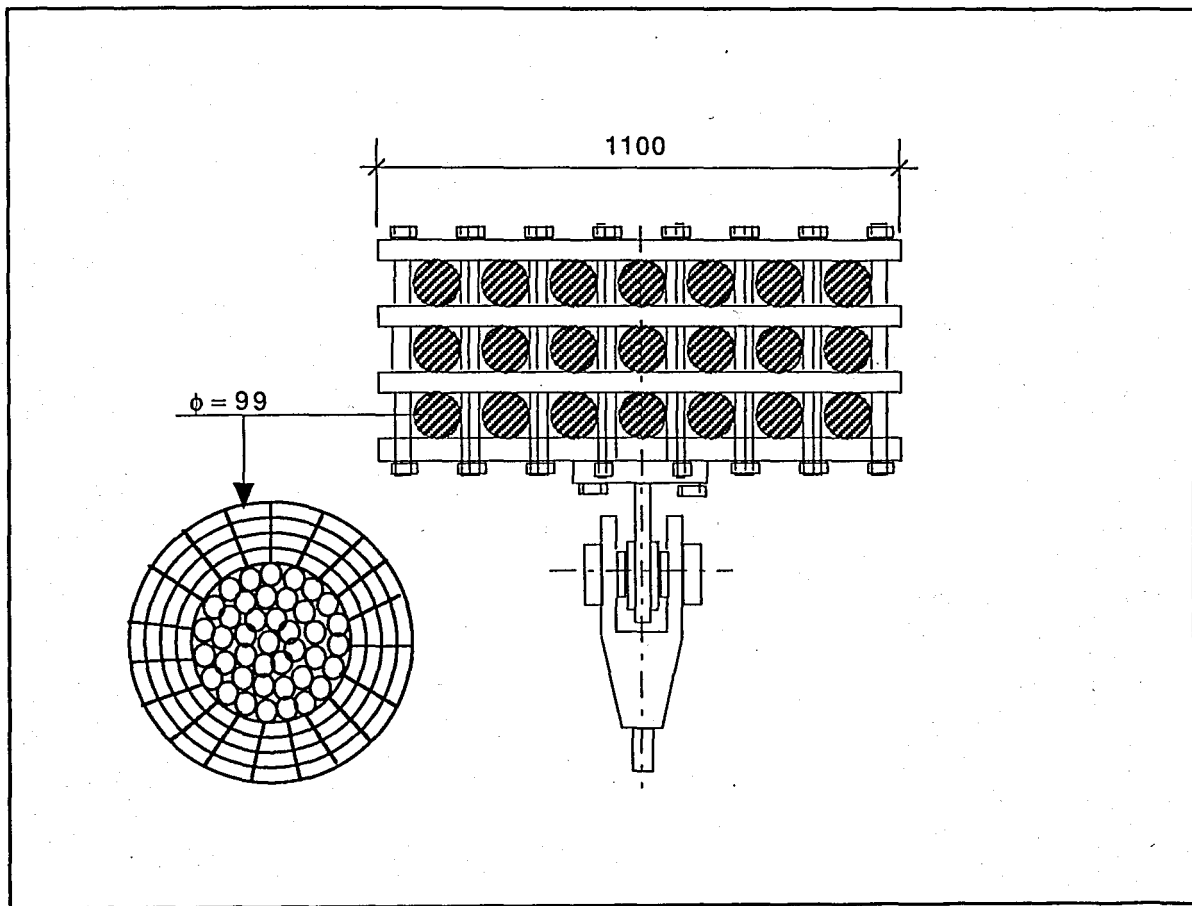
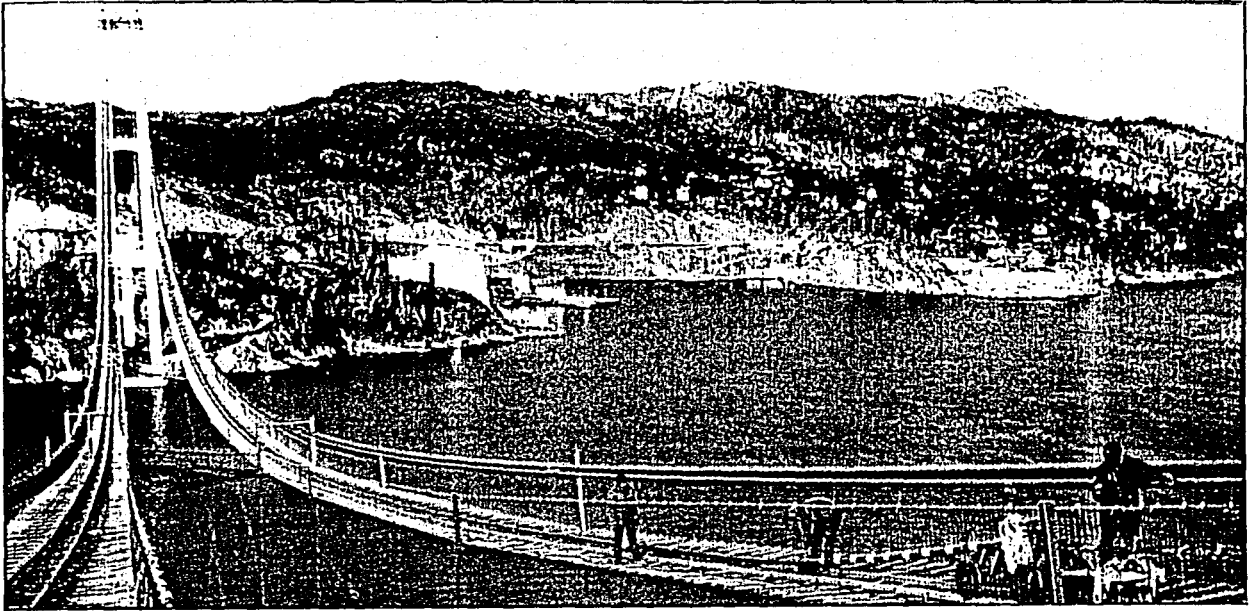

FIGURE 12.7. CABLE (in mm)



**FIGURE 12.8. INSTALLATION OF CATWALK** (*Courtesy of Monberg and Thorsen A/S, 1994*)

Using a winch located at the southern rock anchorage, strands were pulled one by one off the steel drums, located 300 meters north of the North tower, and to the other side over special rollers provided at regular intervals along the catwalk. Following pulling of the first strand, its sag was carefully adjusted until the correct geometry was obtained. This operation, representing an important and difficult phase of the cable installation, requires a reasonable constant air temperature and no sun radiation throughout the operation as the cable length, and thus its sag, is very sensitive to variations in temperature. With a wrong sag, the final elevation of the stiffening girder will become incorrect. The sag of subsequent strands was adjusted to that of the first strand.

The E-modulus required for sag calculations, was determined in tests carried out in conjunction with production testing of the strands. The strands were subjected to a loading/unloading history that closely resembled the expected actions to which it was anticipated they would be subjected during cable installation and latter application of the full suspension span dead load (girder, railings, etc.). At full dead load, the sag at the middle of the suspended span had increased with about 7.5 meters relative to that present following installation (free hanging cables).

The installation of catwalk and cables was carried out over a period of about 6 months.

## 12.8. Stiffening Girder

The stiffening girder, *Figure 12.3*, is an aerodynamically formed steel box girder with sharp edges. Rounded edges would have attracted less wind loading than sharp edges, but also would have resulted in increased production costs. The selected girder is considered to be maintenance friendly, which was an important objective in the selection of general geometry and details.

All external (surface) plates of the girder are plane, with thicknesses ranging from 8 to 12 mm. Further, the girder has 6 mm thick trapezoidal longitudinal stiffeners, and 8 mm thick diaphragms for every 4 meters. Hangers are spaced at 12 meters c/c distance.

External corrosion protection is provided by a sink coating, 100  $\mu$ m. This corrosion protection conforms to that required for all Norwegian steel bridges.

Internally, dehumidifiers are installed at each end of the girder in order to ensure that the relative humidity at all times is maintained sufficiently low (below 40 per cent) so as to prevent corrosion from developing. No protection in the form of surface treatment was applied internally.

Traffic lanes are provided with a 60 mm thick asphalt wearing surface. Total girder weight, including wearing surface, railings and all other installations, is 6900 kg/m. The girder steel alone weighs 4800 kg/m. Steel quality is primarily St 52-3 ( $f_y = 355$  MPa), as defined by the German standard DIN 17100 [19].

Costs of the girder, including production, installation, surface treatment, wearing surface, railings, etc. were about USD 16.6 mill. A brief overview of production and installation aspects is given below.

### A. Production and Transportation

Girders were produced at two former shipyards located 30 km apart in the towns of Moss and Fredirstad on the south-east coast of Norway (south of Oslo). At the first yard, 12 meters long units were produced. These were subsequently shipped (by boat) to the second yard where they were corrosion protected and then welded together to larger segments, normally 36 meters long. Shipping of the girder segments is shown in *Figure 12.9*. Lifting and attachment of the suspenders is shown in *Figure 12.10*.

The girder segments were shipped in two shipments on dummy barges from the yard to the bridge location. This is a distance of about 300 nautical miles, partly across rough waters and open stretches of the North Sea. Each transport, with about 2000 tones of bridge segments piled 3 on top of each other, lasted about 65 hours and proceeded without major problems.

### B. Girder installation/Erection

The considerable height of the towers meant that the floating crane was not able to lift the girder section directly into its final position.

A special "telegraphing" technique with the following six stages was therefore developed [19], [20]:

- (a) The section is lifted by the floating crane at suspenders 3 and 4.
- (b) Suspenders 1 and 5 are attached to the section.
- (c) The section is lowered to its first position of equilibrium.
- (d) The floating crane lifts the back end of the section, in order to attach suspender 2 instead of suspender 5.
- (e) A winch is placed on the already erected bridge deck in order to hold back the section after release of the floating crane.
- (f) While paying out the winch rope the section is slowly swung into its final position at the tower.

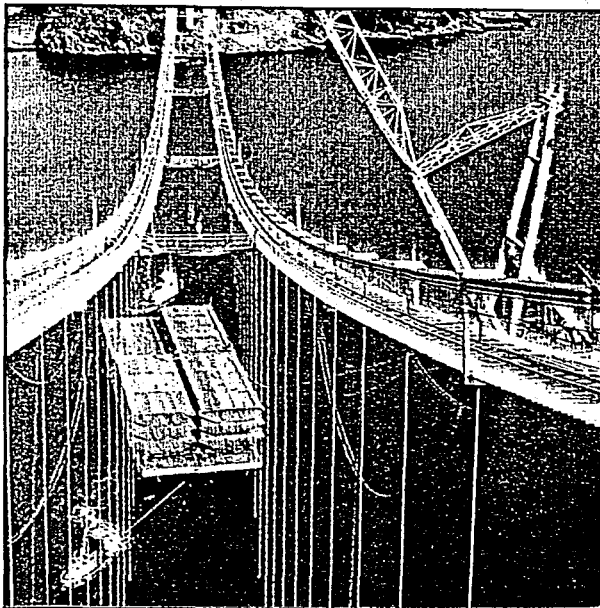

**FIGURE 12.9. SHIPPING OF THE GIRDER SEGMENTS**  
(Courtesy of Monberg and Thorsen A/S, 1994)

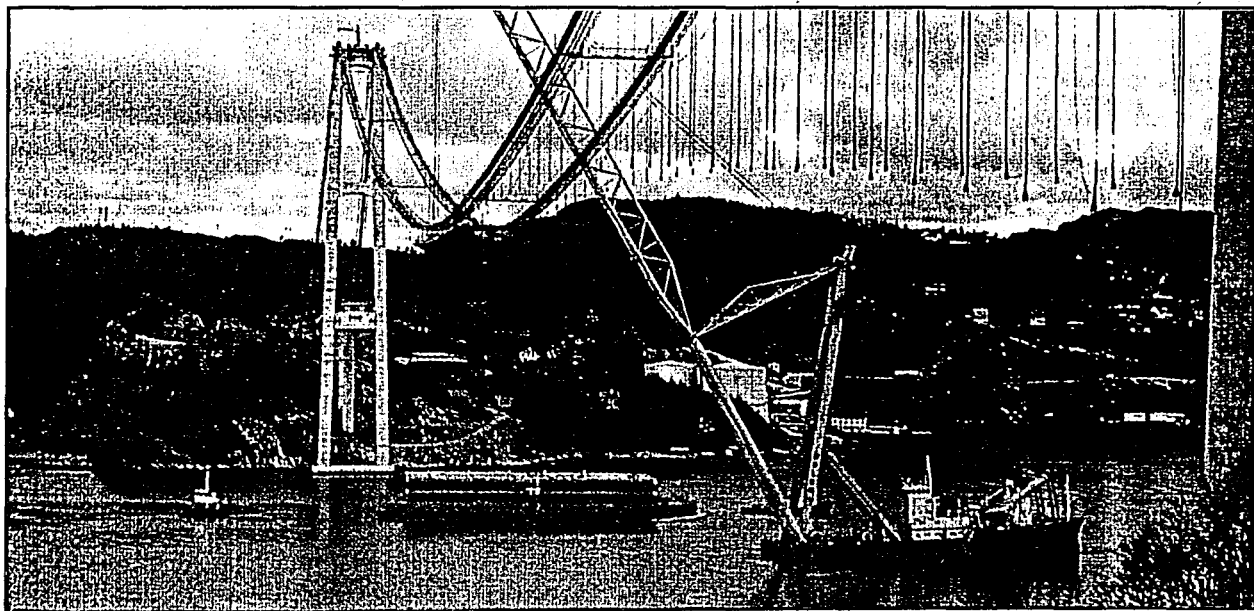

**FIGURE 12.10. LIFTING OF THE GIRDER SEGMENTS**  
(Courtesy of Monberg and Thorsen A/S, 1994)

This procedure is illustrated in *Figure 12.11*. Following completed girder installation, interfaces at temporary connections were welded. To ensure optimal welding conditions, welding locations were preheated and welding carried out under a movable shelter. On the average, about one week was required for welding works at each interface.

The lifting and temporary connecting operations of the 850 meters girder were planned in minute detail by the contractor, and required altogether only 11 days, including a one day break due to unacceptable weather conditions. An upper wind speed limit of 6 m/sec was imposed on lifting operations.

After completed welding, the 23 segment interfaces were finally sand blasted and corrosion protected (zinc coating and painting as described above). From the start of cable installation till final opening of the bridge, about 18 months elapsed.

## **12.9. Concluding Remarks**

Various design and construction aspects of the Askoy suspension bridge have been presented. Some of these are in accordance with standard practice internationally. Others are rather typical for Norwegian practice, such as saddles, cable configuration and cable anchorages. Considerable efforts were made during the design period to provide maintenance -and construction- friendly solutions and solutions giving good economy.

Construction work started in August 1989, and the bridge opened to traffic in December 1992, about 5 months ahead of schedule. Total cost was USD 61.2 mill. Construction works were carried out without accidents and according to initial plans, both technically and cost-wise.

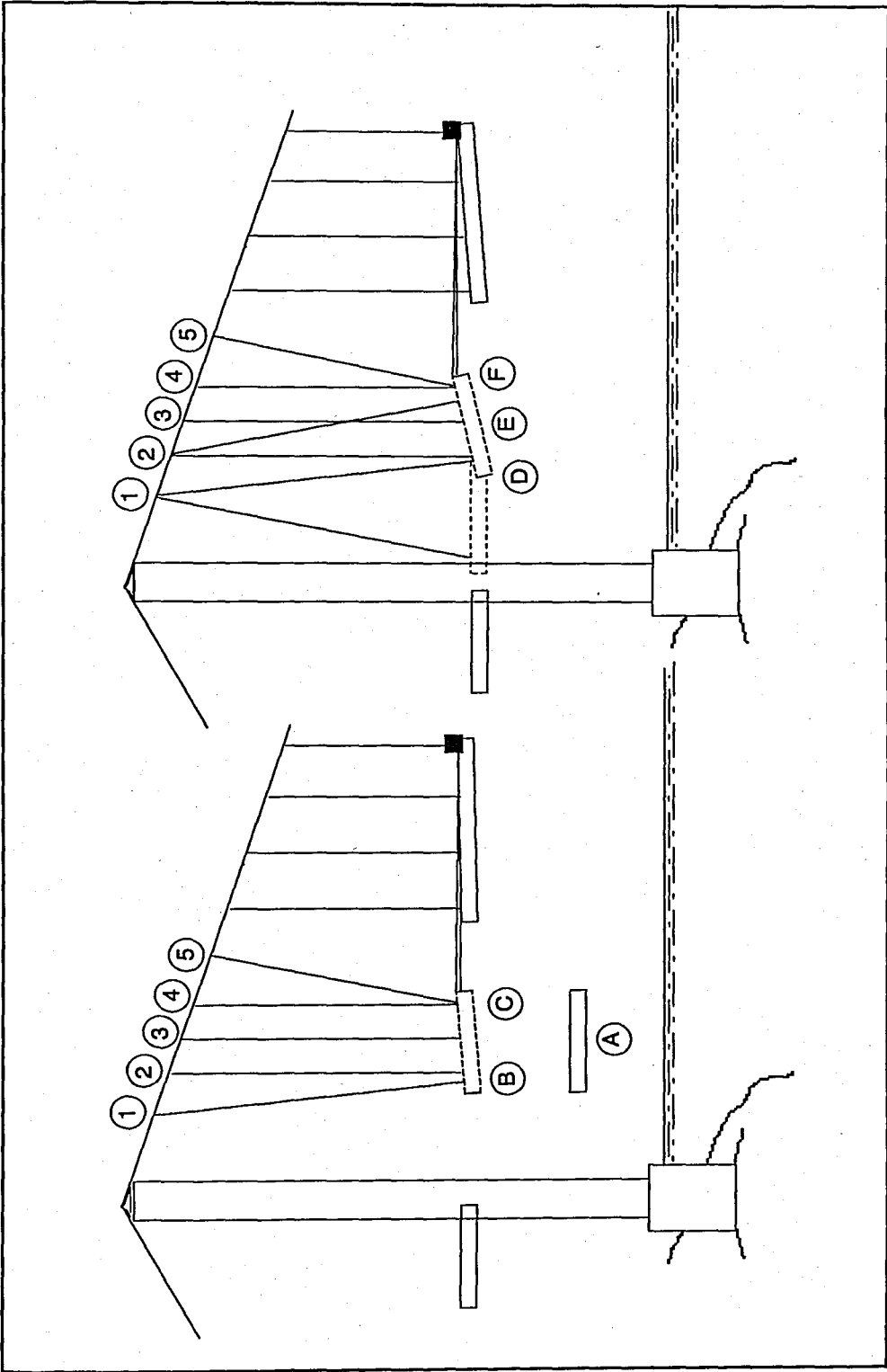

FIGURE 12.11. ERECTION OF THE GIRDER

## 13. CASE STUDY NO.4

### ***NORMANDIE CABLE-STAYED BRIDGE IN FRANCE***

#### **13.1. Introduction**

On August 1984, the last steel plate was welded to close the main span of the Normandie Bridge, which, at 856 meters, is the longest cable-stayed span in the world [21],[22]. The Normandia Bridge, shown in *Figure 13.1* and *Figure 13.2*, will begin its service life in January 1995. This is an appropriate occasion to analyze its design and review the experience gained during the construction thus far.

#### **13.2. Wind Governed Design**

The design of long span bridges is governed by wind and wind effects. The Normandie Bridge helped or inspired the design of other bridges, and it is also true that the Normandie Bridge itself was very much inspired from the suspension bridges designed by Freeman Fox and Partners: UK's Severn Bridge and Humber Bridge, and Turkey's first Bosphorus Bridge. The main aspects of the wind design of the Normandie Bridge are [21]:

(a) The streamlined cross section of the deck, to reduce wind forces and to increase the aerodynamic stability of the bridge. The final shape was selected for specific reason: it had to be adapted to both concrete and steel structures, since the deck is in prestressed concrete in the access spans shown in *Figure 13.3* and in steel in the central part of the main span shown in *Figure 13.4*.

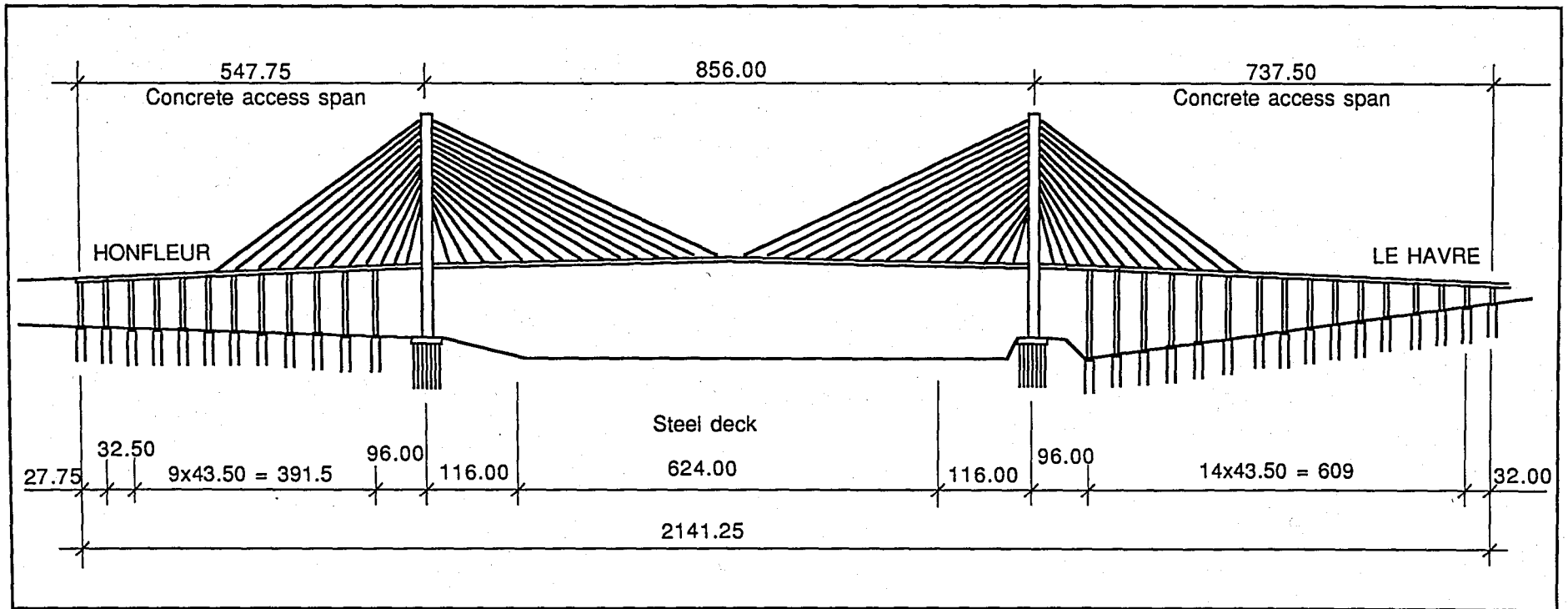
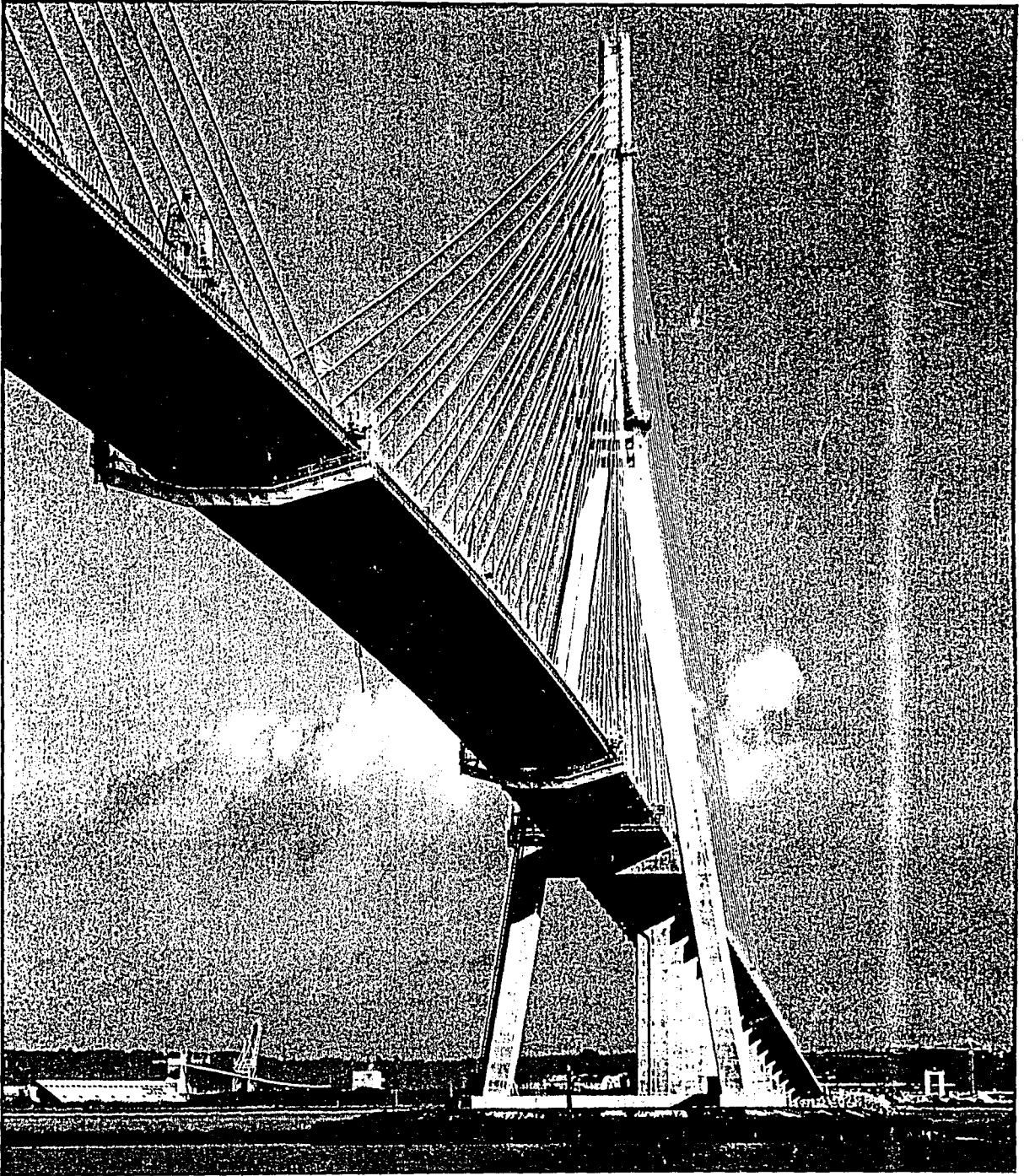

FIGURE 13.1. ELEVATION (in meters)



**FIGURE 13.2. THE NORMANDIE BRIDGE, FRANCE (Courtesy of J. Schneider, 1994)**

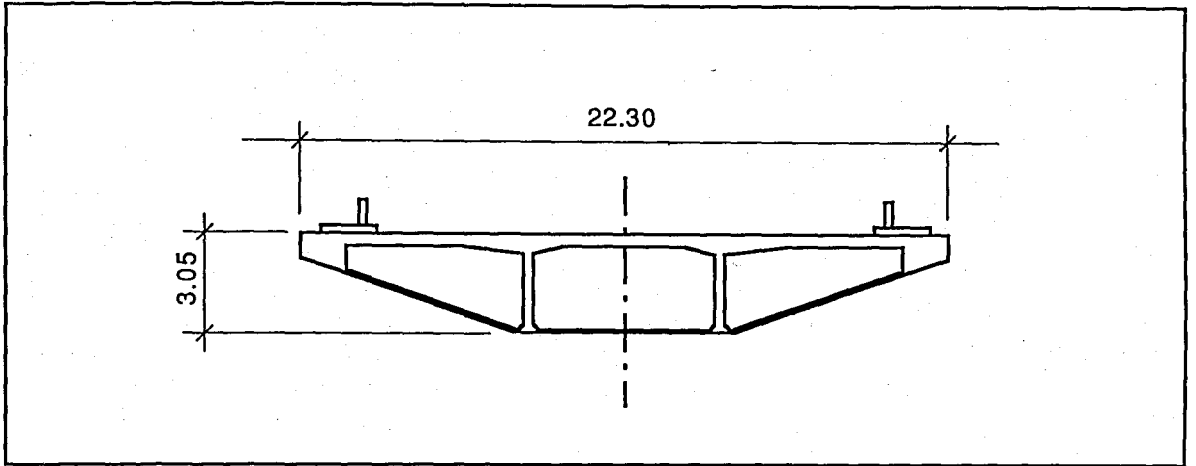

FIGURE 13.3. CROSS SECTION OF THE ACCESS SPAN DECK (In meters)

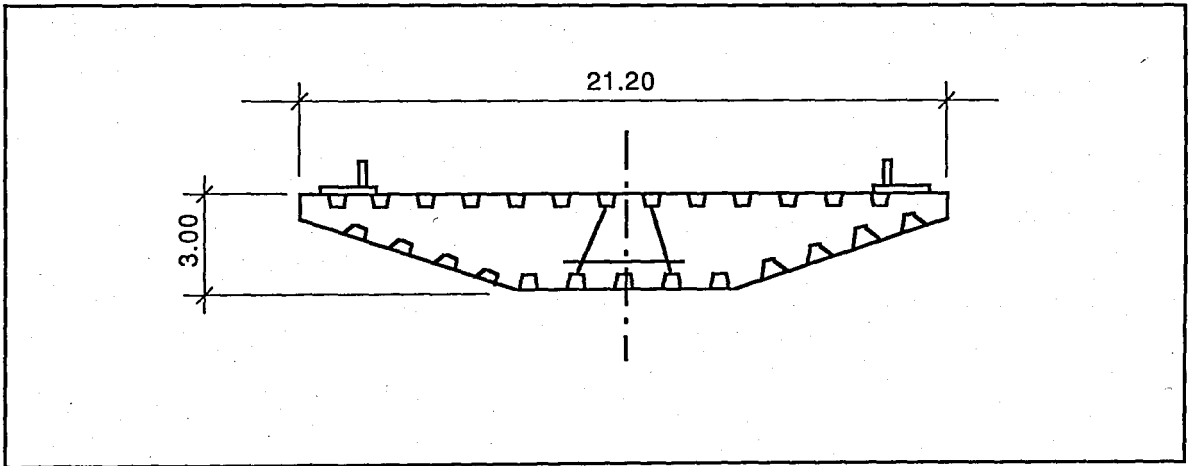

FIGURE 13.4. CROSS SECTION OF THE MAIN SPAN (In meters)

(b) A high torsional rigidity, to clearly separate the vibration periods in torsion and vertical bending. For this reason, the deck is a box girder suspended on both sides. In addition, the pylons have the shape of an inverted Y to concentrate the higher anchorages of cables on the bridge longitudinal axis.

(c) The shape of the pylon - an inverted Y - is also extremely efficient at resisting transverse wind forces .

(d) The concrete and steel composite deck, with concrete access spans on close supports extended at a distance of 116m from each pylon in the central span, as well as the rigid connection between deck and pylons, increases the structure's rigidity. Wind-induced deflections are drastically reduced.

### 13.3. Composite Construction

The second major point in the design of the Normandie Bridge is combination of prestressed concrete and steel. composite designs, where concrete and steel are used to their greatest efficiency, are strongly endorsed by the designer of the Normandie Bridge.

The Normandie Bridge combines concrete and steel for the design of the deck, prestressed concrete in the access spans, on close supports, with an extension in the main span on both sides. Only the central part of the main span is an orthotropic steel box girder, much lighter (9t/m, instead of the usual 45 t/m) to limit the cable size. The use of concrete in the access spans reduces total costs and increases the bridge's rigidity, as well as the backstaying efficiency of all rear cables.

This efficiency combination of concrete and steel in cable-stayed decks had been used before for the design of the Tampico Bridge in Mexico (360 meters, 1988) and of the Ikuchi Bridge in Japan (490 meters, 1991). And prior to that, much valuable experience had been gained about using various materials, such as traditional and lightweight concrete, in Dutch bridges built by the cantilever method (Nijmegen bridges, around 1970). This experience gained in using different weights for a specific structural purpose proved to be extremely useful (the bridges at Ottmarsheim and Tricastin and the cable-stayed bridge over the Elorn River) [21].

The Normandie Bridge also uses a composite design for the upper part of the pylons, where cables are anchored . It is far more efficient to design a steel anchorage box to anchor the cables, since steel plates easily carry tensile stress from back-stays to cables suspending the main span. In addition, it is much easier to fabricate these steel anchorage boxes - or the elements which will constitute them - in a factory than on site in

concrete 100 or 200 meters above ground. To achieve the proper geometry, it is necessary to precisely adjust the position of steel elements which are later completed by concrete walls.

Probably the first application of this technique was in Belgium, for the construction of the Ben Ahin and Wandre Bridges, designed by Greisch and Jean-Maria Cremer. The idea was used again for the Evripos Bridge in Greece and the Chalon-Sur-Saone Bridge in France. The problem was more complex in the Normandie Bridge, with the transverse inclination of cables. A design was developed with Jean-Claude Foucriat, introducing horizontal prestressing tendons to press the concrete walls against the steel anchorage boxes to help the transfer of vertical forces from steel to concrete.

The steel anchorage tower shown in *Figure 13.5* was divided into 21 elements (the lower one being divided into two half-elements) to be lifted by the site crane (capacity: 20t), and welded on site. The typical element shown in *Figure 13.6* was designed to anchor a pair of cables on each side. The main plates were divided in ties for the transfer of forces from the main span to back-stays in order to lighten the elements, reduce in situ welds and facilitate access from the lateral cells of the pylon - with a lift - to the anchorages.

### **13.4. High Performance Concrete**

The main advantage of high performance concrete for standard and medium span bridges is substantially enhanced durability. But for heavily loaded elements, such as the pylons of cable-stayed bridges with long spans, of the concrete deck of the Normandie Bridge, which has to balance the high stresses from wind effects, high performance concrete has great structural advantages.

All concrete on the Normandie Bridge contains silica fume for a characteristic strength of 60 MPa. This allowed for a reduction in the cross section of the concrete in the pylons and deck and thus a reduction in weight and foundations.

### **13.5. Erection of Access Spans**

The erection of access spans on both banks required the contractors to develop a new technology. Classical erection techniques, with Teflon pads, would have produced very significant horizontal forces due to the friction (up to five per cent) and to the slope of the access ramp (six per cent). For this reason the initial design did not use the incremental

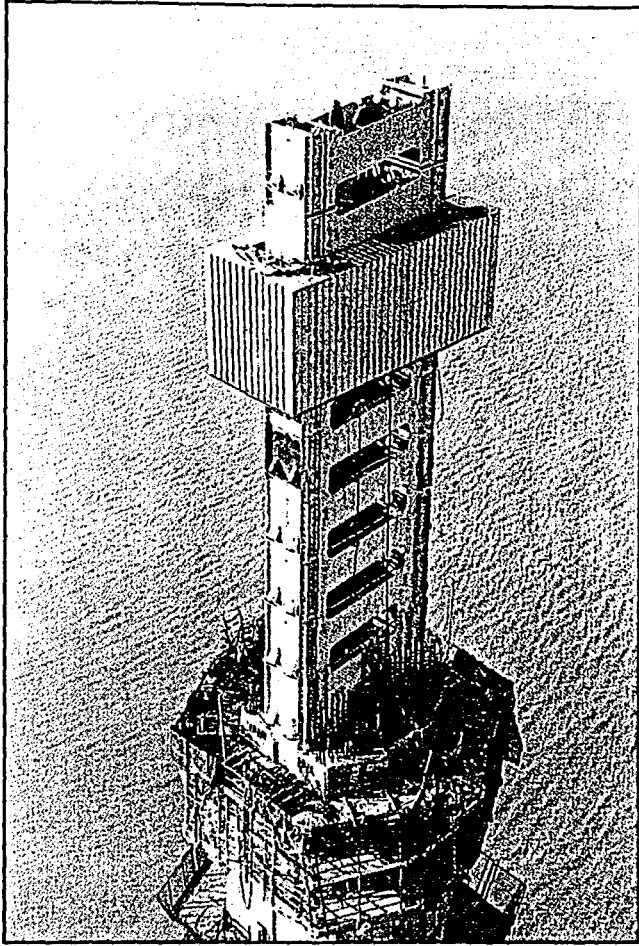

**FIGURE 13.5. ANCHORAGE BOXES, SOUTH PYLON**  
(Courtesy of AFPC, 1994)

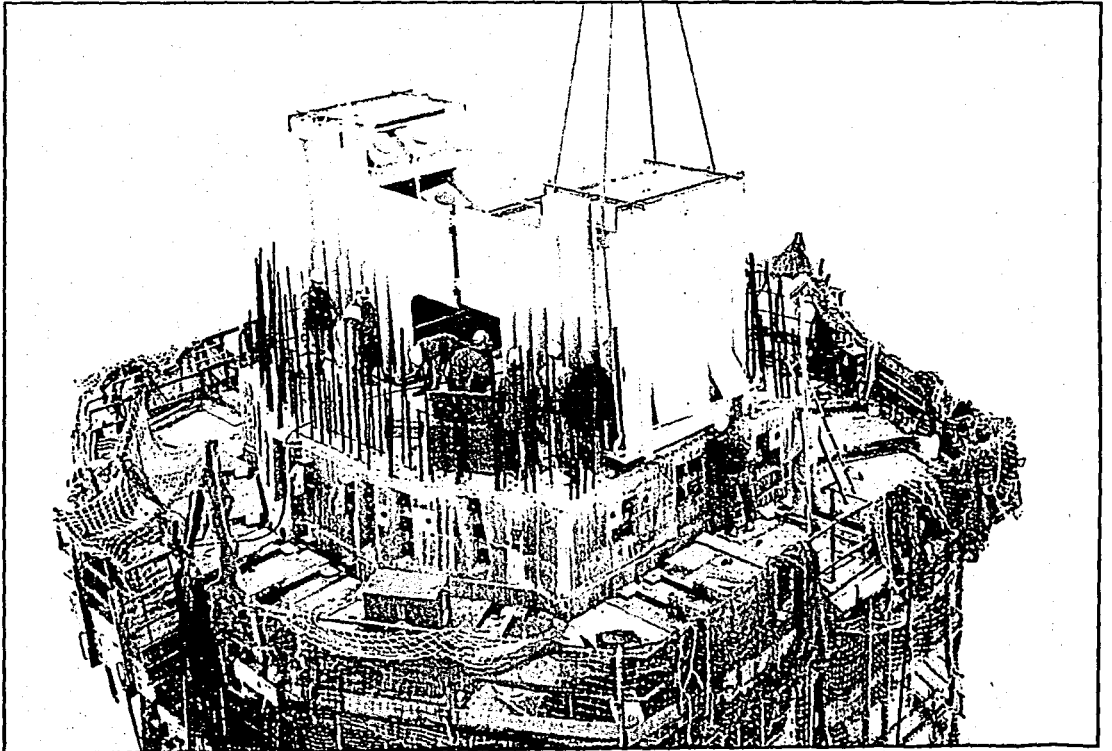

**FIGURE 13.6. INSTALLATION OF AN ANCHORAGE BOX** (Courtesy of AFPC, 1994)

launching method, although it was of great interest due to the complex cross section shape and to the high reinforcement ratio necessary to resist wind forces.

To be able to use it despite the slope the contractors invented a so-called "staircase" method for horizontal span launching as shown in *Figure 13.7*. The deck is supported on each pier by two trapezoidal blocks - one on each side - which can slide horizontally on the pier. This movement is permitted by special bearings, made of a series of small rollers, on top of the pier. After the forward movement, the deck is lifted by jacks commanded from a central computer and the trapezoidal blocks are pushed backwards, ready for a new launching step. The launching operation proceeds by successive launching steps: 15cm horizontally and then 9mm vertically to correspond to the slope of six per cent.

Such a procedure was only made possible by the use of serious of sensors, to control horizontal and vertical movements on all supports, and of a central microcomputer which could command horizontal and vertical movements. It was of special importance, of course, that vertical movements be the same on all supports at any time.

In addition, this new technique reduces the necessary manpower during launching, since control is only necessary at supports, which can be done at the central command from measurements obtained by sensors or video cameras.

### **13.6. Erection of the Main Span**

The 116 meters long concrete cantilever, which extends the side spans in the main one on each bank, and the 96 meters long last side span have been built by the balanced cantilever method from the pylon with the help of temporary stays as indicated in *Figure 13.8*. In the last side span, the closure was made 6m before reaching the pier with the incrementally launched typical spans.

The steel part of the main span, 642 meters long, has been erected by the cantilever method from the completed access spans with the help of a mobile derrick to lift the successive segments. The erection of the girder is shown in *Figure 13.9*.

### **13.7. A New Generation of Cables**

The preliminary design called for locked coil cables, which were considered very well adapted to such long spans, but which are unfortunately very heavy.

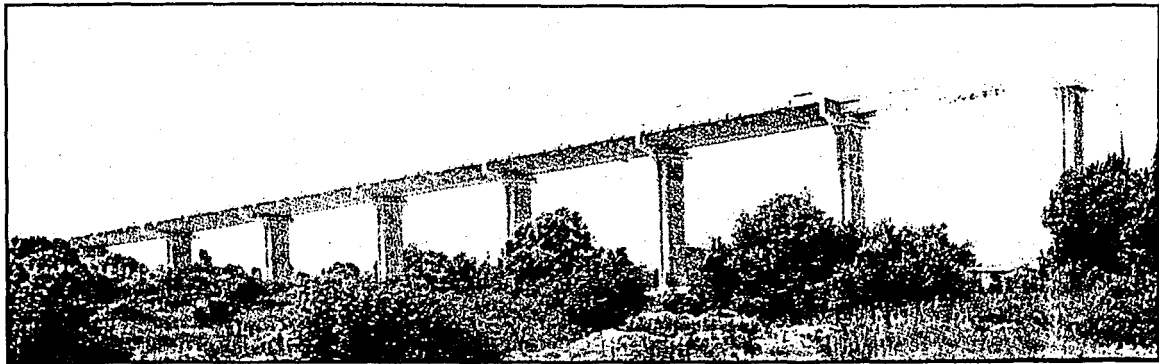

**FIGURE 13.7. CONCRETE ACCESS SPANS LAUNCHED FROM THE NORTH BANK**  
(Courtesy of AFPC, 1994)

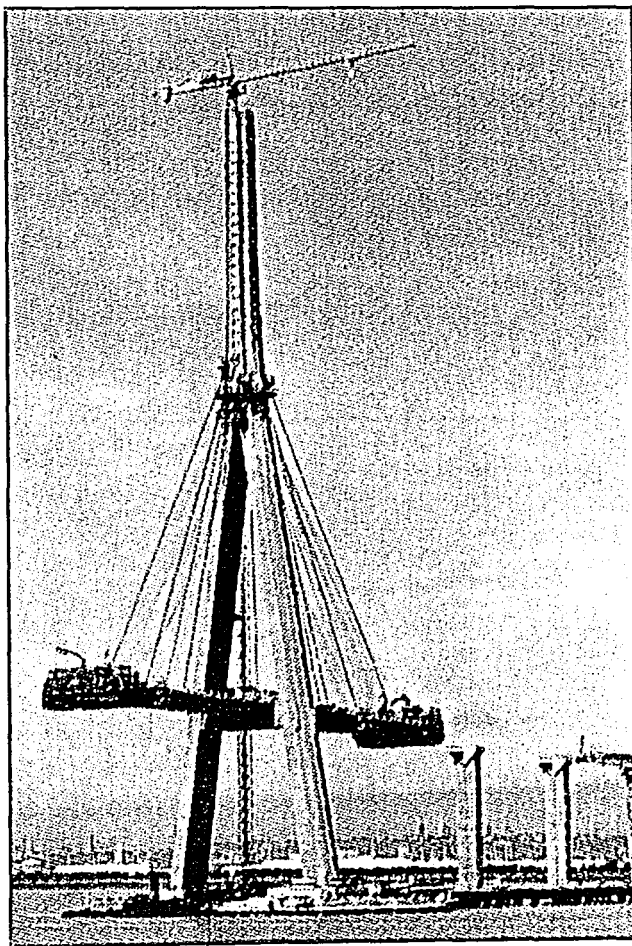

**FIGURE 13.8. CONSTRUCTION OF THE DECK AT THE SOUTH PYLON**  
(Courtesy of AFPC, 1994)

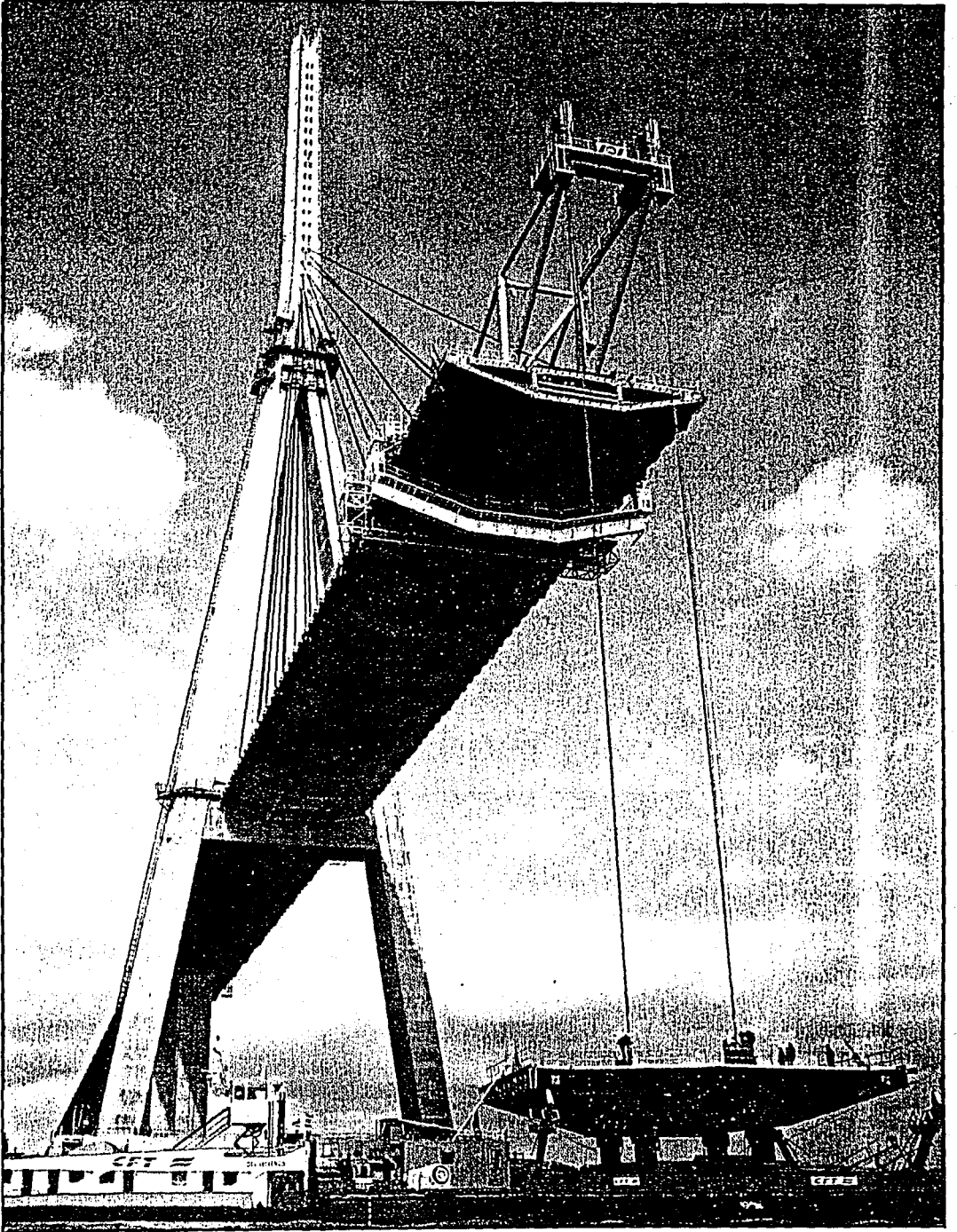

FIGURE 13.9. ERECTION OF THE STEEL GIRDER (Courtesy of J. Schneider, 1994)

For this reason, the contractors proposed alternative cables made of individually protected strands of hot-dip galvanized wires which were re-drawn to keep all their structural characteristics. After coiling and after the corresponding thermal treatment, the voids between wires were filled with oil wax to repel any water. The strand was then protected by extruded high density polyethylene by extruded high density polyethylene at least 1.5 mm thick.

These strands were placed and tensioned one-by-one. Individual placement was extremely economical, but tensioning required a new technique, already developed by the cable supplier for the erection of three bridges: the Arrade and Guadiana Bridges in Portugal, and the Chalon-sur-Saone Bridge in France [21].

The first strand of each cable is tensioned to a computed value and equipped with a pressure cell which gives the tension at any time. Each new strand, when installed, is tensioned to have exactly the same tension as the pilot strand at that precise moment, which is given by the cell. All strands thus receive the same tension, which is the desired one if the initial tension of the pilot strand had been appropriately computed. If not, an adjustment is made the same way. This process is not susceptible to influences from temporary operations, such as the movement of construction equipment.

Finally, cables received an external duct made of a series of two half-elements which are forced into each other. These ducts are not for corrosion protection; they are air and water permeable. They aim at reducing drag forces and avoiding rain-induced vibrations of the cables. In addition, they totally eliminate the vibrations of strands in the bunch which makes each cable, which are produced by wind interaction between strands by a kind of "wake" effect.

### **13.8. Interconnecting Ropes**

In his design for the Messina Straits, Fritz Leonhardt envisioned connecting all cables in each plane of the cables by tying ropes, which aimed at increasing the apparent modulus of elasticity of the suspension, lowered by sag effects in long cable-stayed spans.

In some other bridges, such as the Faro Bridge in Denmark or the two cable-stayed bridges of the Kojima-Sakaide route of the Honshu-Shikoku link, ropes were installed to limit cable vibration which was rain-induced in the Faro Bridge and coming from wake effect in the Japanese bridges.

The purpose is totally different in the Normandie Bridge: due to the very long span of the bridge, the main vibration period for vertical bending would have been of the same magnitude as the vibration period of the longer cables, 4.5 s, compared to about 4.0 s. In the situation, it was feared that cable vibrations would be induced by deck movements. Interconnecting ropes were designed to totally change the vibration periods of cables, at least transversally, reducing them to 1.25 s and less.

Four ropes connect all cables in each plane of stays. Their tension was selected to avoid de-tensioning from vibrations produced by wind turbulence. Their constitution is composite, with steel and plastic to increase fatigue resistance because it is obviously difficult to simultaneously achieve a high damping coefficient and a high fatigue resistance.

### **13.9. Concluding Remarks**

The design and construction of very large bridges which go beyond existing limits require the strongest determination from the Owner, who must invest enormous confidence in, and support of, the engineers in charge. The most dangerous tempests that audacious projects face are not produced by wind on site, but by antagonistic opinion that find a willing audience.

The success of the Normandie Bridge is due in large part of the confidence and support that the project received from the Owner, the Road Director and the local authorities. Some organizational aspects and some episodes during construction indicate the decisive importance of human factors.

The Owner gave the design engineers total responsibility for the design and granted them complete freedom to assemble the design team. Under these circumstances, improvements could be introduced at each step of the project, with no consideration other than efficiency. This is far superior to design competitions, now preferred by some administrations, where projects can be selected based not always on structural aspects, and where designers can become prisoners of their initial sketches and of premature options and decisions.

Although there was no public money in the Normandie Bridge, the French government had to approve the project. The Road Director at the same time, Jean Berthier, decided to invite an assessment of the design by an international group of experts: Marcel Heut (Project Manager of the Tancarville Bridge), Henri Methieu, Charles Brignon, Roger Lacroix, Rene Walther and Jörg Schlaich. This group proposed various amendments, some of which included in the final design.

Nevertheless, some engineers from one of the erection contractors considered the wind forces to have been underestimated and, thus, the safety questionable. The debate became public, even international.

The owner and the Road Director decided to consult Alan Davenport to evaluate the wind tunnel tests and the estimated wind forces. He approved the performed analyses and recommended some additional wind tunnel tests, the results of which were even more favorable than the first evaluations. This confirmation of the design helped the project very much, and from the summer of 1991, all contractors worked with enthusiasm and energy to complete the bridge on schedule, within budget and up to the prescribed standards of quality.

Any decision can be questioned, any action criticized. The clear conclusion is that a complex and ambitious project like the Normandie Bridge cannot be successfully realized without a strong Project Manager - as Bertrand Deroubaix has been for this project - to guide it over the years from conception to completion, even when questioned from many sides. Going further than every before in any given fields calls for courage. The Owner and the local authorities remained totally confident in the design and in the engineers in charge, even in difficult times. This was decisive for success; complex structures cannot be built with hesitations and doubts!

## 14. CASE STUDY NO.5

### ***THE NEW LACEY V. MURROW FLOATING BRIDGE IN THE USA***

#### **14.1. Introduction**

In the late 1930s the Washington State designed and built the first permanent highway concrete floating bridge in the world [23]. The bridge was opened to traffic in July 1940. The bridge was later named as the Lacey V. Murrow Bridge in honor of the director and chief engineer who was responsible for adopting the concept of a concrete floating bridge. After 50 years of service, the bridge was closed to traffic for renovation and upgrading to meet current highway geometric standards. During renovation some pontoons took in excessive water and sank on November 25, 1990. Soon after the sinking, the Washington State Department of Transportation (WSDOT) put together a value engineering (VE) team to evaluate options and make recommendations for replacement. After evaluating 11 possible options, the VE team recommended the construction of a floating structure with new pontoons. The new structure would be designed to meet current interstate standards, utilize state of the art technology, provide better service life and lower maintenance [7].

This new bridge shown in *Figure 14.1* and *Figure 14.2* keeps the name of the original bridge which is the "Lacey V. Murrow Floating Bridge." It is 2130 meters long. The roadway is 17.1 meters wide with three 3.66-meter traffic lanes and two 3.05-meter shoulders. These are the 3 eastbound lanes for the I-90 Interstate route across Lake Washington. The westbound lanes are on an adjacent floating bridge known as the Third Lake Washington Floating Bridge or Homer Hadley Bridge.

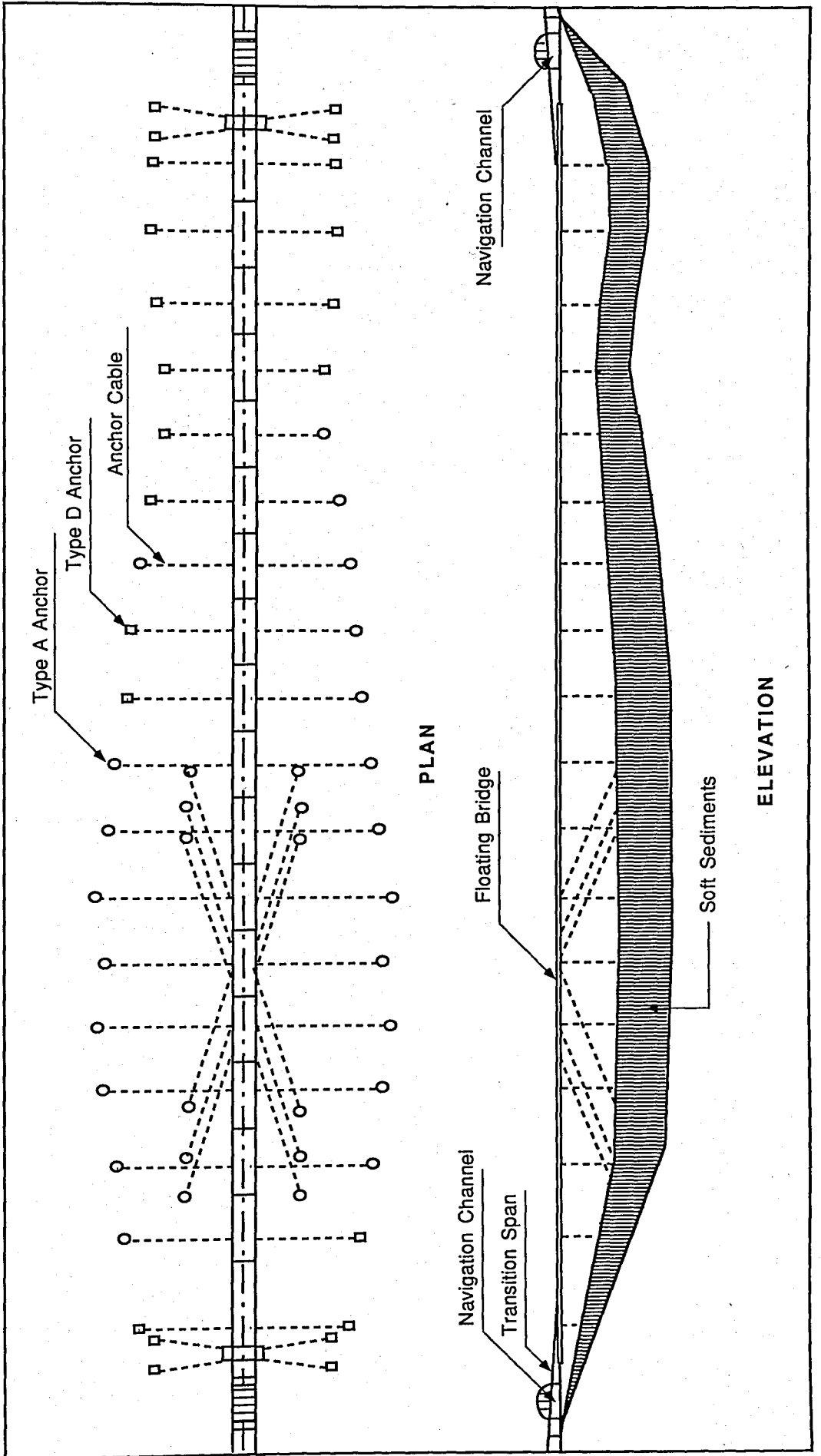
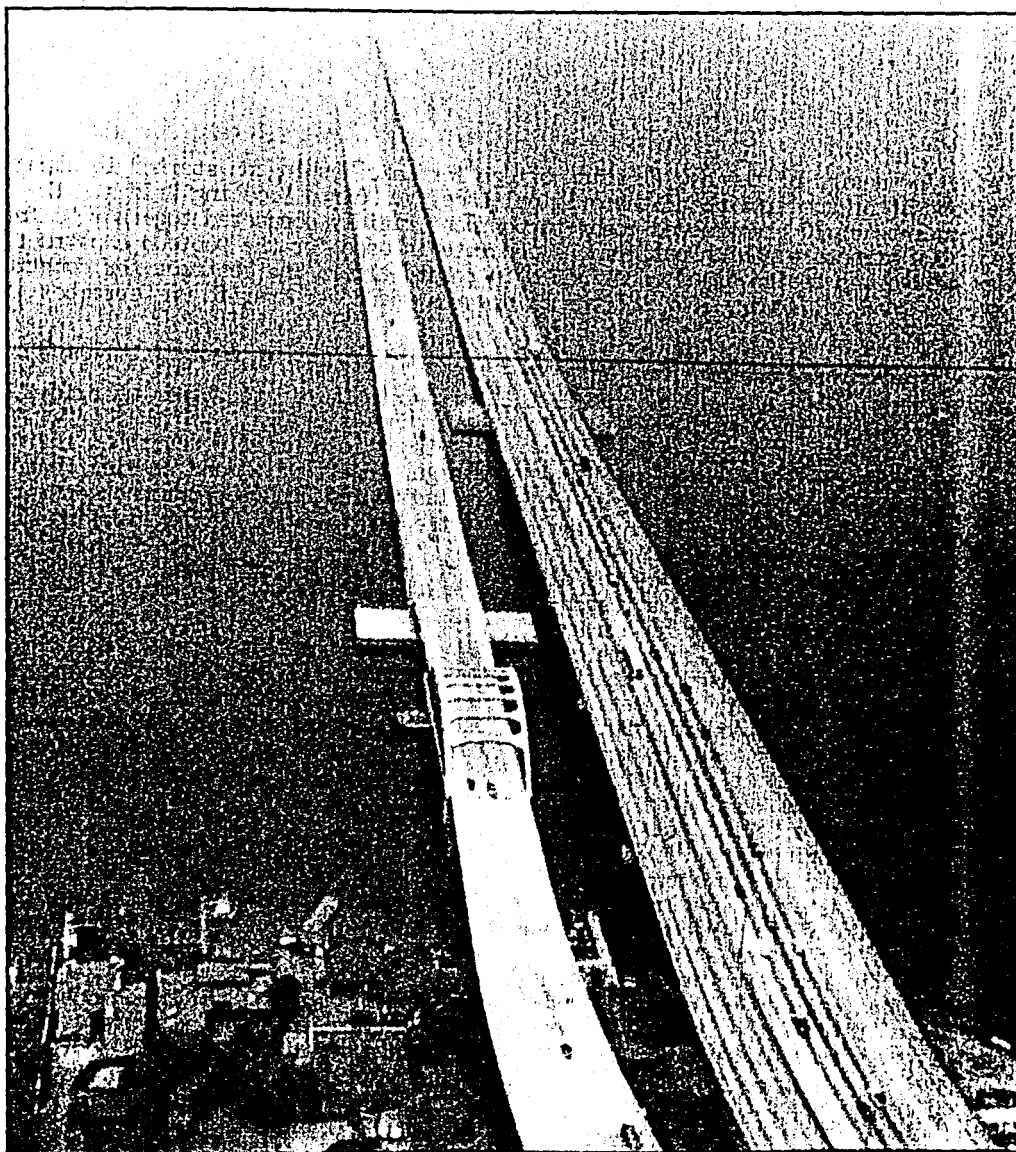

FIGURE 14.1. THE NEW LACEY V. MURROW FLOATING BRIDGE



**FIGURE 14.2. THE I-90 FLOATING BRIDGES: ON THE LEFT IS THE NEW LACEY V. MURROW BRIDGE (Courtesy of J. Krokeborg, 1994)**

## 14.2. Lake Washington

Lake Washington is located in Seattle, Washington State, USA. It is a fresh water lake carved by glaciers about 14000 years ago. The deepest part of the ancient bottom of the lake was estimated to be greater than 140 meters below the present water level. The ancient bottom of the lake was lined with glacial, interglacial and postglacial sediments of dense till, lacustrine deposits and outwash sand and gravel. Subsequent deposits consisted of poorly consolidated materials having a maximum thickness of approximately 72 meters. These deposits included a mixture of clay, silt and organic material with occasional lenses of strata of sand, gravel, volcanic ash and compact silt. These deposits do not form good foundation materials for conventional bridges pier construction.

Lake Washington is connected to the Puget Sound and beyond via Lake Union and the 13 km long Ship Canal. Ship Canal is terminated at the western end by 2 locks, commonly known as the Ballard Locks. One lock is 24.4 meters wide and the other 9.1 meters wide. These locks serve as passages for pleasure boats and commercial vessels. These locks also keep the lake level fairly constant. The extreme seasonal variations are predicted to be 1.2 meters drop and less than 0.3 meters rise from the normal water level.

Because of its great width and depth of water, and the extensive depth of soft sediments, Lake Washington poses a challenge to highway planners and engineers to cost effectively cross this obstacle. The concept of a floating bridge has been proven to be the least costly alternative to span across Lake Washington [7].

## 14.3. The New pontoons

The new bridge consist of 20 prestressed concrete pontoons rigidly connected together to form a continuous structure. A typical pontoon is prestressed longitudinally and measures 110 meters long, 18.3 meters wide, 5.1 meters deep and has a water draft of 3 meters. It is of cellular construction similar to a conventional concrete box girder bridge. The interior is divided into compartments with watertight bulkheads to control flooding and to safeguard against progressive failure. Cross section of a pontoon is shown in *Figure 14.3*. The pontoons are designed to remain afloat with the most likely damage scenario. For example [7]:

- (a) the side wall of a pontoon could be damaged by accidental loads, such as by of a collisions by boats, resulting in the flooding of two to four outboard compartments. The resulting loads cause very small vertical deflection and rotation in the bridge.

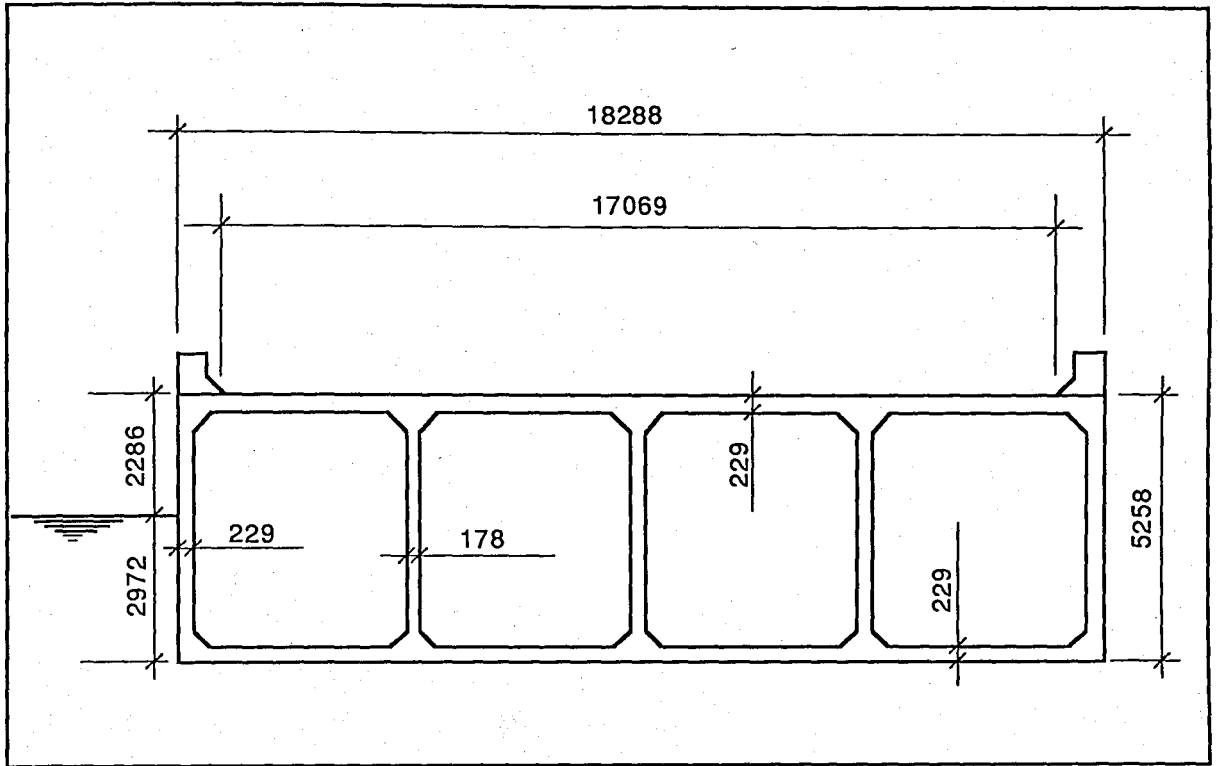

FIGURE 14.3. TYPICAL CROSS SECTION (In mm)

(b) in a more extreme case, where the structure is completely breached, the watertight compartment arrangement will prevent progressive flooding and progressive failure.

Each pontoon is moored by a pair of anchor cables, one on each side of the pontoon. The anchor cables are 60.3 mm diameter galvanized structural strands meeting ASTM A586 and having a minimum ultimate strength of 303 Mg. The anchor cables are connected to two types of anchors, Type A and Type D, placed in the bottom of the lake.

The type A anchors are placed in deep water and very soft soil. They are constructed of reinforced concrete fitted with pipes for water jetting. The anchors weigh 86 Mg each. They are lowered to the bottom of the lake and the water jets are turned on allowing the anchors to sink into the soft lake bottom to fully embed the anchors. Anchor capacity is developed through passive soil pressure.

The Type D anchors are placed in shallow and deep water where the soil is too hard for water jetting. These are gravity type anchors. They consist of solid reinforced concrete slabs, each weighing about 272 Mg. The first slab is lowered into position and then followed by subsequent slabs. The number of slabs is determined by the anchor capacity required.

#### **14.4. Design Criteria**

The design is based on the AASHTO Standards Specifications for Highway bridges supplemented with design criteria developed for floating bridges in Washington State [7]. The design follows the same good practice as recommended for a conventional post-tensioned concrete bridge. The design criteria assure that the floating bridges meet functional, economical and practical requirements, perform reliably and be comfortable to ride on, safely sustain damage from accidental loads and extreme storms without major damage or sinking, require minimal maintenance and safeguard against progressive failure due to water leakage.

#### **14.5. Structural Design and Analysis**

The design of floating bridges in Washington State has gone through several stages of progressive development since the first floating bridge was designed in the late 1930s. The design has gone from empirical methods to realistic approach, from the equivalent static approach to dynamic analysis, from computer modeling to physical model testing. Research is being conducted to gain better understanding of the wind-wave-structure interaction.

Designing for static loads, such as dead and live loads, is very straightforward using the classical theory on beam on elastic foundation. Designing for the response of the structure to winds and waves is more complex, because of the random nature of these environmental loads. The wind and wave characteristics for the 100-year design wind storm are: 129 km/hour wind, 1.22 meters significant wave height and 3.7 s wave period.

A dynamic analysis was performed to determine the wind and wave induced bending moments, shears, torsion, deflections and rotations in the structure. The dynamic analysis is based on the theory of ship motions and the principles of naval architecture. The underlining assumption is that the flow at one section through the floating bridge does not affect the flow at any other section. Using the strip theory, the problem of wave-structure interaction can be solved by the frequency domain analysis. A finite element structural computer model of the floating bridge is used to solve the equation of motion to determine the responses of the bridge. The maximum structural responses can then be predicted using spectral analysis and probability distribution.

#### 14.6. High Performance Concrete

The concrete in the floating bridges in Washington State has performed well in various exposure conditions. The concrete design strength varies from 21 Mpa to 45 Mpa compressive strength, and concrete of low permeability, low shrinkage, good workability and availability. Research and development for such a concrete mix started in June 1991. Trial mixes of different types of cement, various combinations of silica fume, fly ash and other ingredients were tested with primary concern for watertightness and durability. The final mix design was tested for workability in a mock-up of typical walls and slab sections including post-tensioning ducts and rebars.

The mock-up test provided valuable information regarding methods of placement, consolidation, curing and finishing. The lessons learned in the mock-up test were incorporated into the construction specifications.

The final concrete mix includes silica fume and fly ash. This concrete mix has average 28-day compressive strength in excess of 69 MPa, permeability less than 1000 Coulombs as tested in accordance with AASHTO T-277 Rapid Chloride Permeability Test, and shrinkage less than 0.0000040 as tested in accordance with AASHTO T-160 Length Change of Hardened Concrete. The specifications for the mix are as follows [7]:

|                 |                    |
|-----------------|--------------------|
| Portland Cement | 284.0 kg           |
| Silica Fume     | 22.7 kg to 31.8 kg |
| Fly Ash         | 45.4 kg            |

|                   |          |
|-------------------|----------|
| Aggregate Size    | 12.7 mm  |
| Water Content     | 127.0 kg |
| Water/ Cementious | 0.33     |
| Air Entrainment   | None     |
| Admixtures        | Yes      |
| Slump             | 229 mm   |

### 14.7. Special Features

As this is a floating bridge, many safety features have been incorporated into the design to safeguard against progressive failure and to provide early warning of water entry. Some of the special features are:

- (a) each pontoon is divided into small watertight compartments to confine flooding;
- (b) water sensors are installed in each watertight compartment for early detection and early warning of water entry;
- (c) a bilge piping system is installed in the compartments for pumping out water.

### 14.8. Construction

A USD 73.8 million construction contract was awarded to General/Rainier of Seattle to build the 2130 meters long floating bridge. The contract provided 900 calendar days to complete the project with an incentive clause of USD 18500 each day for early completion. The contractor followed a very aggressive construction schedule to complete the work as quickly as practicable [7].

The pontoons were constructed in two graving dock was prepared to build three pontoons at a time, while the smaller graving dock could only build two at a time. The contractor's initial schedule was to complete, because of start up problems and learning to work with the relatively new high performance concrete. The contractor worked diligently with the concrete supplier to adjust the concrete mix to improve workability. Through constant effort in improvement of construction methods and skills, casting cycles were reduced to 12, 9 and finally 8 weeks. After the initial learning period, the contractor was generally pleased with the performance and benefits of the concrete. The concrete did not take a quick initial set but remained workable for many hours.

The high early strength of the concrete enabled post-tensioning to start sooner. There was very little repair, rework or patching. After the pontoons were completed, the tide gates were opened at high tide to flood the graving dock and float the pontoons.

The pontoons were then towed to a nearby outfitting dock where the pontoons were joined in pairs. Each pair of pontoons was then towed to the bridge site, where the final jointing and anchoring took place. A completed and floated pontoon is shown in *Figure 14.4*.

The contractor came up with a very cost effective and time saving way to cast the 56 anchors required for this project. The anchors were constructed on the deck of a flat barge. From setting and stripping were serviced via shore crane. The barge was towed a kilometer upstream to the batch plant to place concrete. Once the concrete has cured, the barge was towed back to the yard where the forms were stripped before continuing its journey to Lake Washington. Heavy crane was used at the lake to place the anchors at the specified locations in the lake bottom.

The contractor used many innovative ways to keep productivity high. The construction was substantially complete by August 1193. The contractor was one year ahead of schedule. Based on the terms of the incentive clause, the contractor earned a bonus of USD 6.7 million.

## 14.9. Conclusions

On September 12, 1993 the new Lacey V. Murrow Floating Bridge was opened to traffic, one year ahead of schedule and within budget. It forms the final western link of budget. It forms the final western link of the I-90 Interstate highway that stretches more than 4800 km from Seattle to Boston, USA.

The lessons learned from the failure of the original bridge and the success of new bridge are very valuable to the engineering community. These lessons have advanced the state of the art of floating bridge design, analysis, materials selection, and construction. Good marine practices have been given full consideration in the design, construction and maintenance of the new bridge, which is stronger, wider and more durable than the original bridge.

All in all, floating bridges are cost effective alternatives for crossing large body of water with unusual depth and a soft bottom. For site conditions like Lake Washington, a floating bridge is estimated to cost 3 to 5 times less than a long span fixed bridge, a tube or a tunnel.

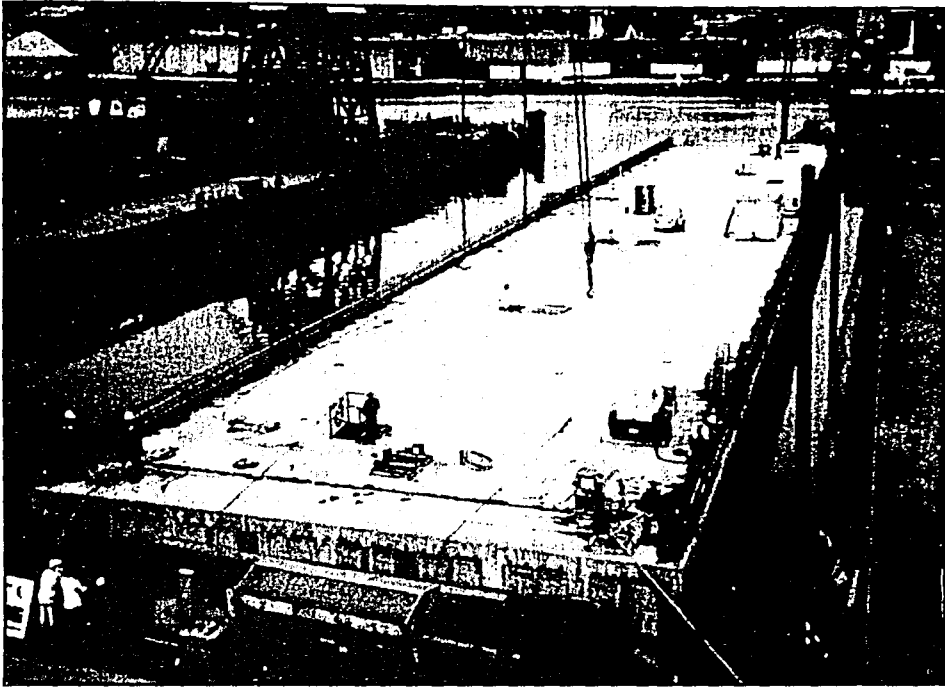

**FIGURE 14.4. COMPLETED AND FLOATED PONTOON**  
*(Courtesy of J. Krokeborg, 1994)*

## 15. CASE STUDY NO.6

### **SALHUS FLOATING BRIDGE IN NORWAY**

#### 15.1. Introduction

The Salhus bridge on highway 1, 23 km north of Bergen, crosses the Salhus fjord on the coast of western Norway [24]. The bridge has replaced a car ferry service between the mainland and the island Flatoy. The total bridge length is 1615 meters, consisting of a high level cable stayed bridge 369 m long, and a floating bridge 1246 meters long, including a transition ramp on the floating bridge as shown in *Figure 15.1*. The bridge construction started July 1991. The cable stayed bridge was finished by September 1 1993 according to schedule. the total bridge crossing is opened to traffic in June 1994.

#### 15.2. The Salhus High Level Bridge

The cable stayed bridge shown in *Figure 15.2* consists of a main span cantilever of 163 meters from one H-shaped tower across the ship channel of 32x50 meters. The outer end of this cantilevered is supported by a monolithic T-structure on the floating bridge anchor abutment. This T-structure also supports the transition ramp from the floating bridge, and the expansion joints are located to give the best balance of loads from the cable-stayed bridge and the transition ramp.

The main span cantilever is stabilized by a part of the approach bridge which has a total length of 190 meters and a typical span of 28 meters. An expansion joint is provided at the abutment. The main span is suspended by 12 pairs of stay supported from the tower.

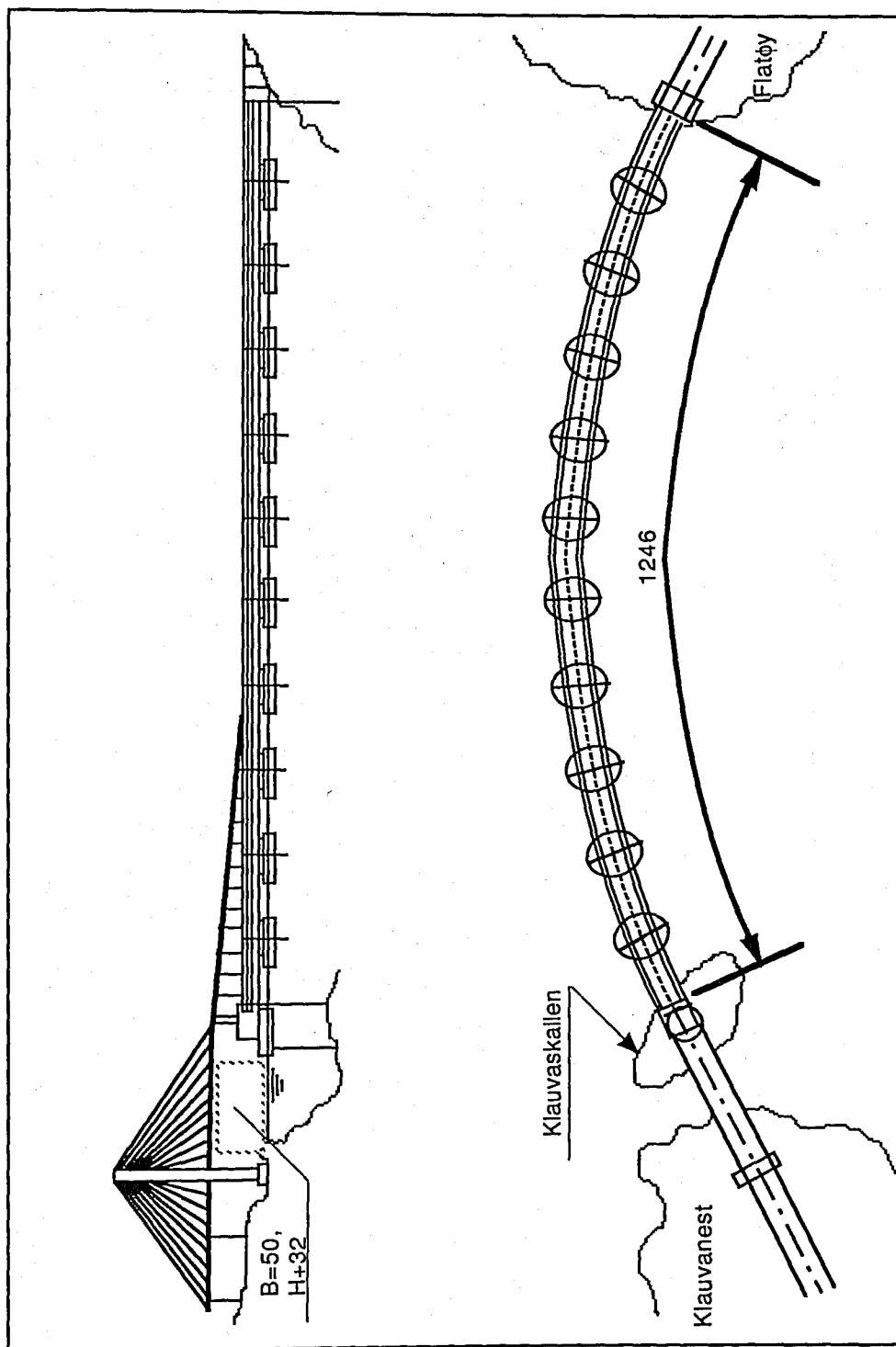

FIGURE 15.1. PLAN AND ELEVATION (in meters)

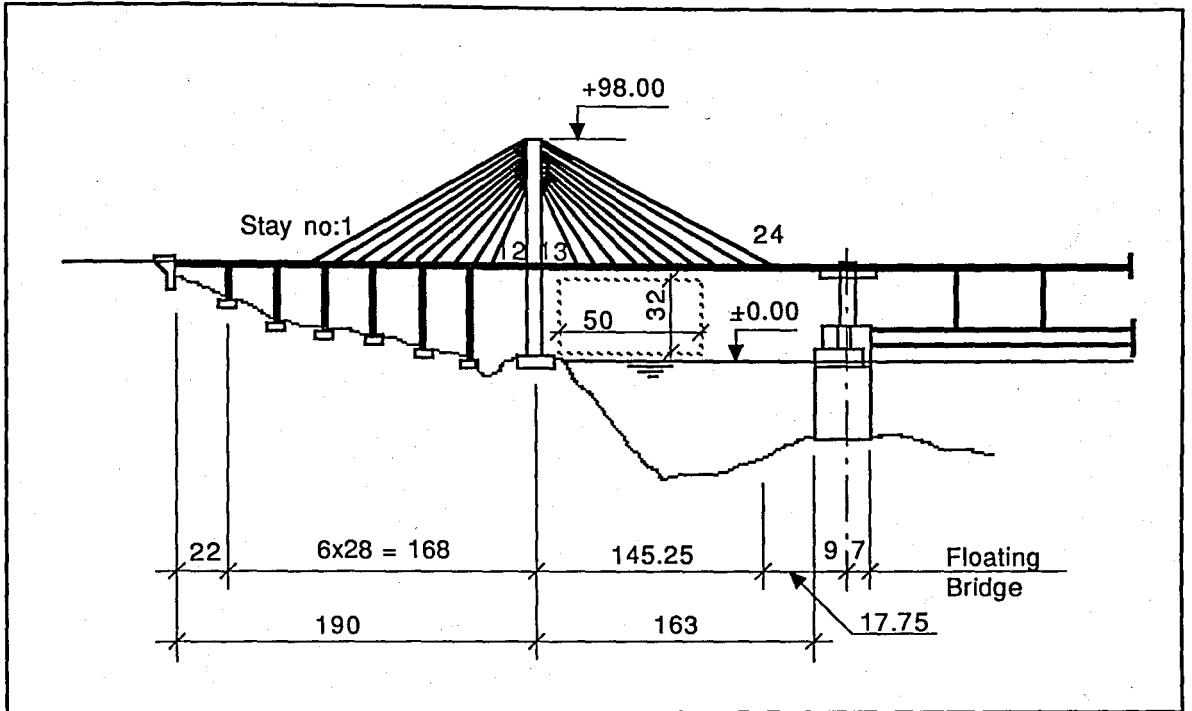

FIGURE 15.2. CABLE-STAYED BRIDGE ELEVATION (In meters)

The structure is designed for the wind speed of 26.9 m/s (10 min. mean at elevation 10 m above sea level and 100 years return period) with turbulence intensities (ratio to  $V_{10}$ )  $I_H = 0.20$  horizontal and  $I_V = 0.10$  vertical.

This cable-stayed bridge was selected for construction from other alternatives evaluated and submitted for tendering as it seemed to provide high aesthetical qualities with an economic and functional design.

The owner of the bridge is at the Norwegian Public Roads administration (PRA), county of Hordaland. The total bridge is designed by the PRA Bridge Department with Aas-Jacobsen A/S as their main consultant. The consultants team also included Instanes A/S and Sovik and Kloster A/S as subconsultants for the high level bridge and Veritec as subconsultants for the floating bridge. The main contractor was Selmer A/S. Architects have been a group consisting of Lund and Slaatto, Lunde and Lovseth and Hindhamar-Sundt-Thomassen [24].

## A. Evaluation of Alternatives

For the high level bridge the following alternatives were evaluated in the preliminary design;

- (a) Cable-stayed bridge in concrete;
- (b) Arch bridge in steel;
- (c) Cantilever bridge.

For architectural and technical reasons alt.c was dropped. Both alt.a and b were submitted for tendering. For alt.a, bridge beam designs in light weight aggregate concrete C55 (LC55) and normal weight concrete C65 were evaluated. (C65 refers to a concrete with a cube crushing strength of 65 Mpa on 100 mm cubes according to Norwegian Standard 3473).

Using the known unit prices for concrete works including stays at that time, the beam design in LC55 was slightly more economic than the design in C65, and was therefore adopted, giving savings in stay quantities and form traveler. The tendering showed the following construction costs ;

- (a) Alt.a - Cable-stayed bridge: USD 10.7 mill.
- (b) Alt.b - Steel arch bridge: USD 9.86 mill.

However, the arch bridge required additional cost with respect to the foundation on the floating bridge anchor abutment in addition to ship tendering for the lower part of the arch. These additional items were included in the tender for the floating bridge. When taken into consideration, the cable-stayed bridge turned out to be approximately USD

145 000 cheaper. In addition this alternative was also less dependent on the progress of the floating bridge anchor abutment. Hence it was decided to built the cable-stayed bridge. The tendering also showed that the estimated cost difference between designs in light weight and normal weight concrete was not confirmed. In fact the cost difference was marginal de to a considerable increase in the unit price of LC55, which proved to be approximately twice that of C65. The preliminary estimates had assumed a 50% difference.

## B. Bridge Beam

The main span bridge beam in LC55 is shown in *Figure 15.3*. This design was chosen to give easy construction combined with sufficient structural and aerodynamic stability. the depth/span ratio was 1/18.

The main span beam is monolithic with the cross beam in the tower, and has a typical span of 12 meters between stay anchors. A cross beam is provided for every pair of stay anchor. Posttensioning tendons are provided in the longitudinal main beams for global forces after the bridge is completed, and in the transverse beams for local and stay anchor forces. The stay anchors are designed in normal weight concrete C55 and are prefabricated in place. This design makes it possible to support the form and form traveler with the permanent stays and anchors during concreting of each new bridge segment. The construction method is shown in *Figure 15.4* and *Figure 15.5*. One external steel strut from each prefabricated anchor of the segment under construction to the previous already completed anchor is provided to carry the horizontal component of the stay force during concreting of the new segment.

## C. Tower

The tower shown in *Figure 15.6* is designed in normal weight concrete C45. An H-shape design was considered to be more suitable than an a-shape, as it is easy to construct and render itself to simplicity in all stay anchor details. Also the foundation topography as well as aesthetic considerations favored the H-shape.

Each leg has a box section with dimensions B/L/T, where B is 2400 mm, L varies from 4983 to 4000 mm and T is 400 mm typical and 1000 mm where the stay anchors are located. Posttensioning is provided in each crossbeam and as hoop tendons in the stay anchorage zone.

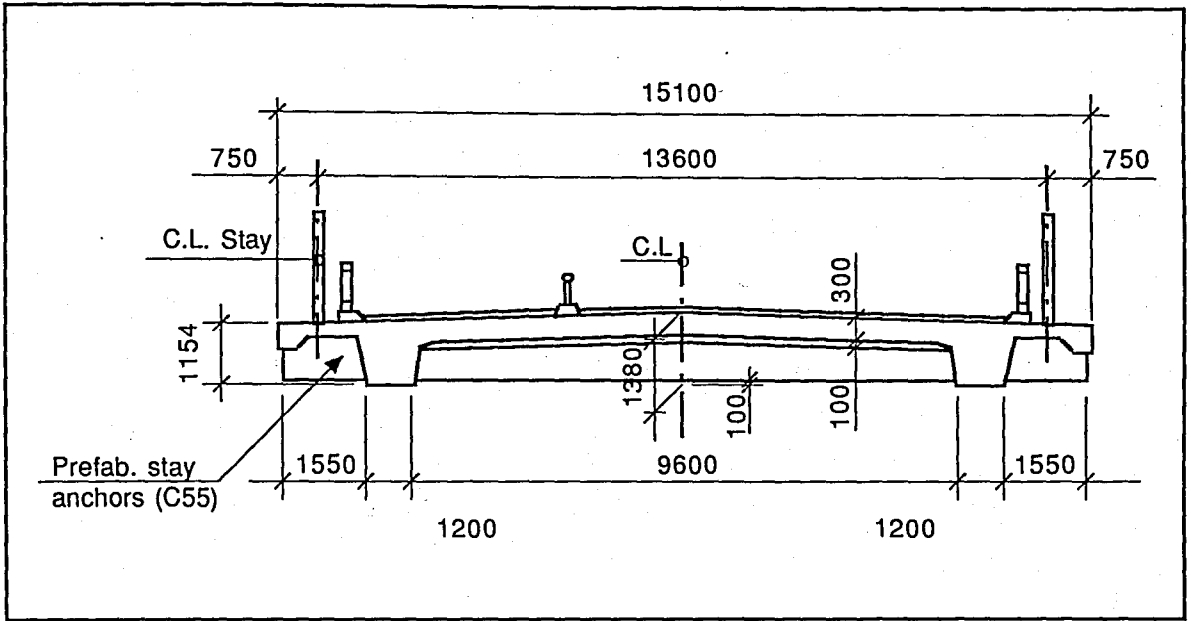

FIGURE 15.3. MAIN SPAN BRIDGE BEAM (In mm)

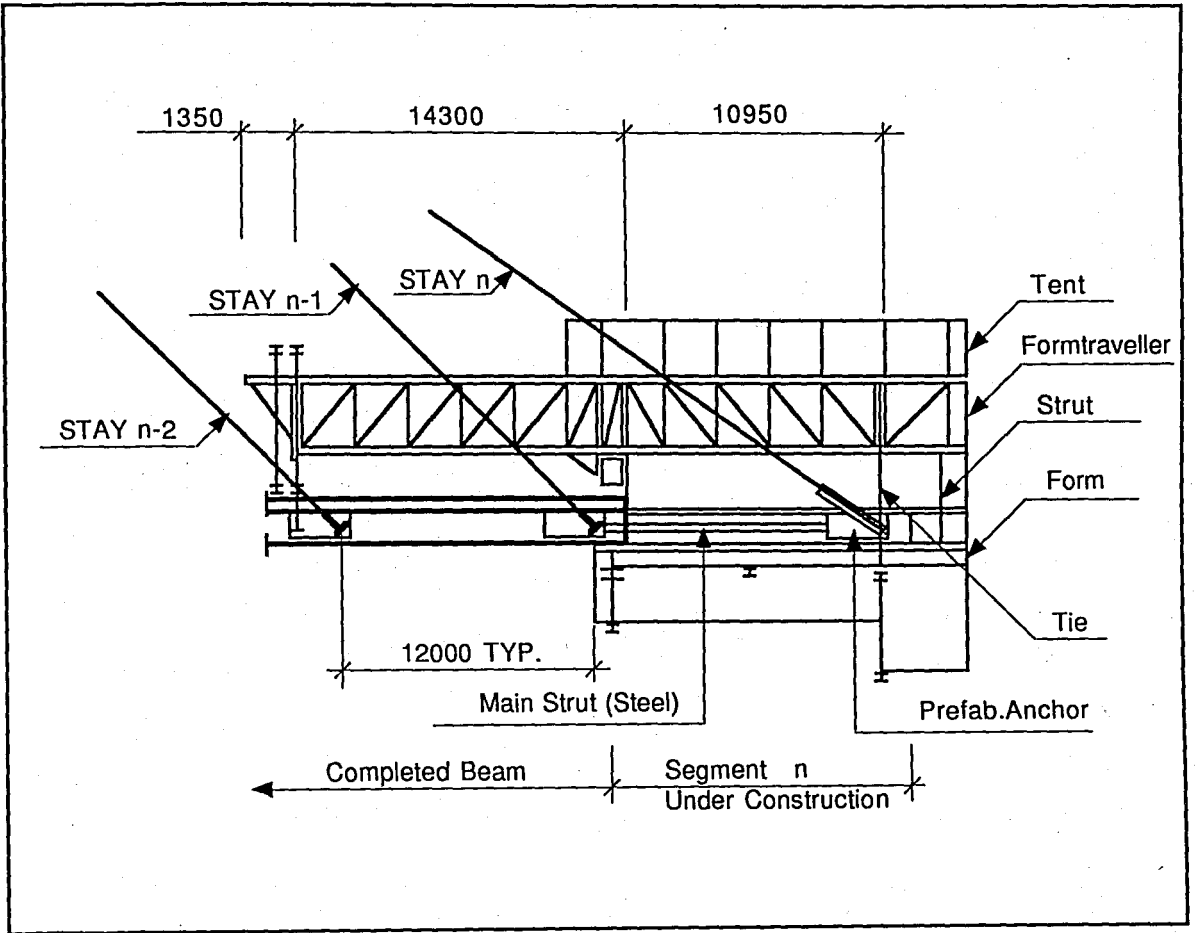
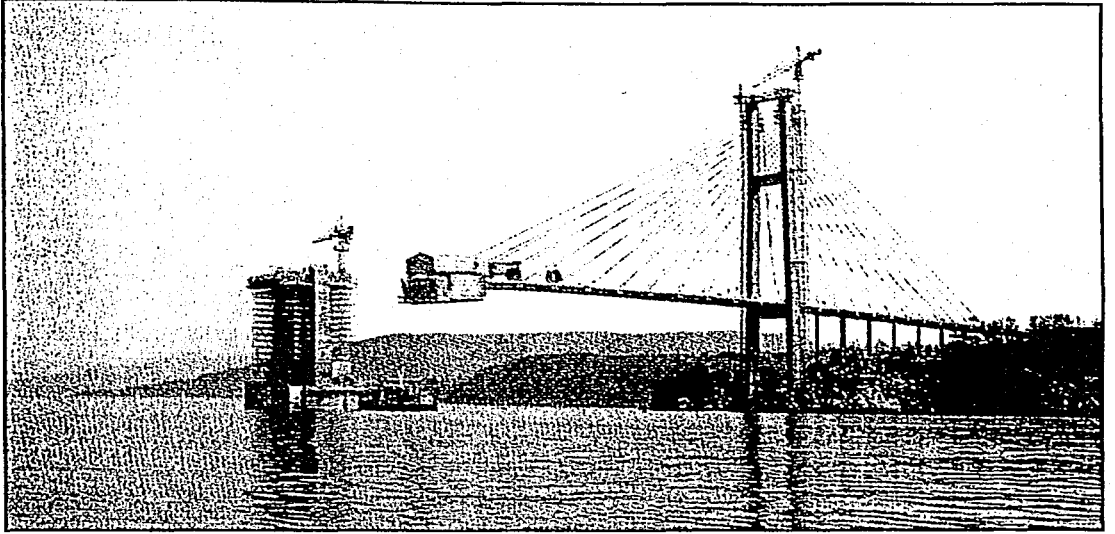

FIGURE 15.4. CONSTRUCTION METHOD (In mm)



**FIGURE 15.5. ERECTION OF THE CABLE-STAYED SPAN**  
*(Courtesy of McGraw-Hill, 1994)*

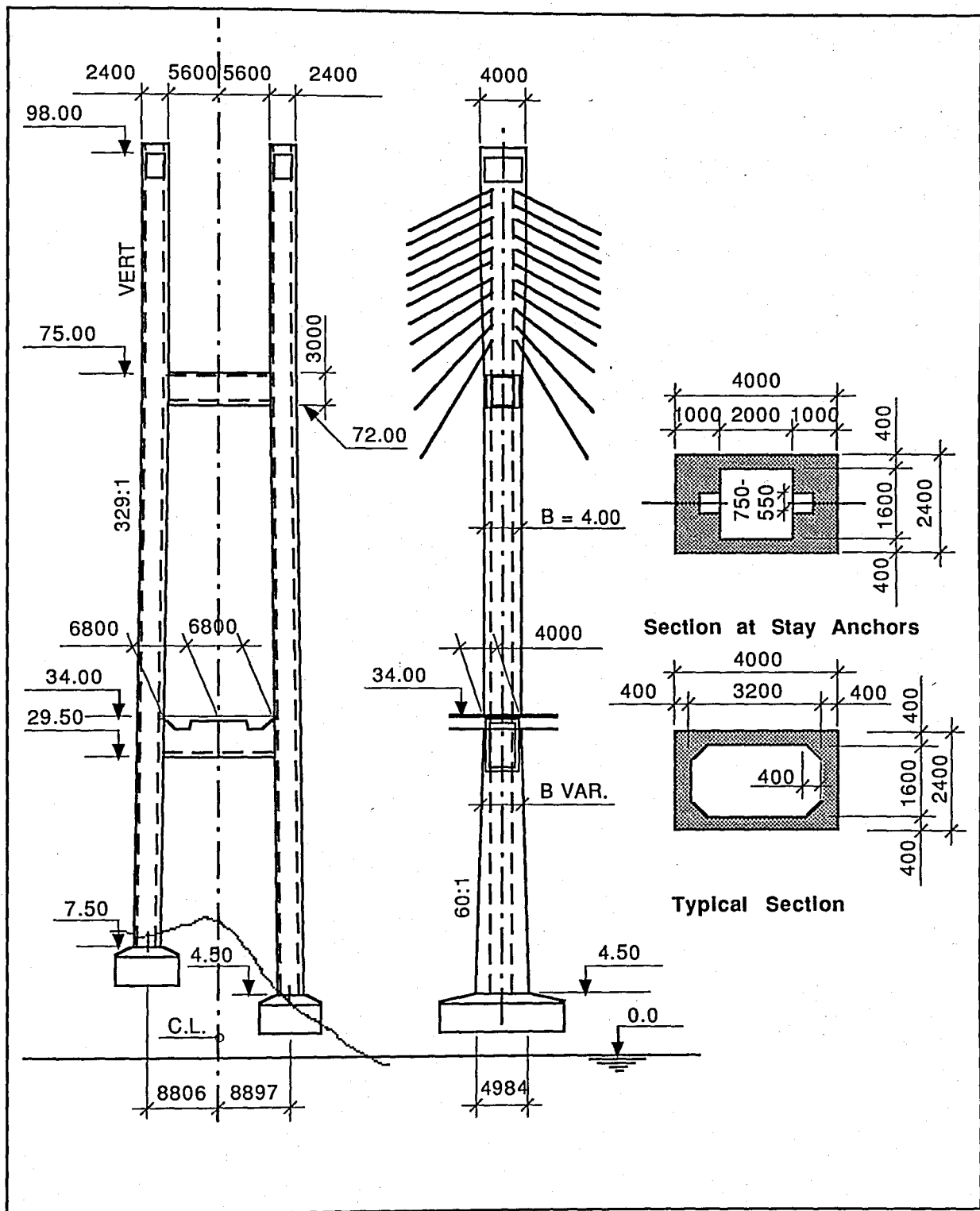

FIGURE 15.6. TOWER (in mm)

## D. Stays

Fully prefabricated stays were considered necessary for this bridge which was constructed during severe weather conditions in the winter period in western Norway. Different stay alternatives were specified by the Client and included in the tender documents - Locked coil ropes, 17 mm wire and strands. The corrosion protection system was specified for each type.. The Stahlton stays with galvanized 7 mm wires, HiAm-anchors and high density polyethylene (PE) tubes filled with special grease were finally chosen. The PE-tubes are strengthened in the area of the neoprene washers (dampers) near the anchors. Here an extra PE protection tube was provided together with a stainless steel plate protection bearing against the washer which have a PTFE wearing surface vulcanized on the inner circumference. Also secondary stiffening wires in stainless steel are provided, interconnecting the stays to prevent stay vibration.

## E. Construction

The bridge was designed to combine easy construction methods with structural and architectural requirements. The construction methods described below were already taken into consideration by the engineers before tendering. For this rather complex bridge we considered this strategy to be an important part of the design and fundamental for the total economy.

As shown on *Figure 15.4*, the permanent stays/and stay anchors were used to support the form traveler during concreting of the main span bridge beam. The required bending stiffness of the form traveler was specified by the consultant to use minimum 80 per cent of that of the bridge beam. Furthermore, the form was required to be clamped to the finished cantilever to avoid differential rotation at this point between the completed beam and the new segment under curing. The detailed design of the form traveler was done by the contractor [24].

### 15.3. Design of the Salhus Floating Bridge

The project involves a several kilometers of access roads including a tunnel, but the main elements are a high-level cable-stayed bridge providing a ship channel and a floating bridge as shown in *Figure 15.7* [25].

During pre-engineering of the bridge several alternatives were investigated. Two alternatives were worked out in sufficient detail for tendering. One was a concrete box girder and the other a steel box girder which both were supported on pontoons. The costs for the two alternatives proved to be quite similar, but the steel solution was selected due to a favorable construction schedule.

The steel box girder of the floating bridge forms a circular arch with a radius of 1700 meters in the horizontal plane. The girder is supported on 10 pontoons. The pontoons are positioned with a center distance of 113.25 meters and acts as elastic supports for the girder. The girder is designed without internal hinges. The bridge follows the tidal variations by elastic deformations of the girder.

There are two traffic lanes and a pedestrian sidewalk. Further, the bridge is designed for a future widening to three traffic lanes and addition of a new cantilevered sidewalk. The typical cross-sections of the bridge are shown in *Figure 15.8*.

### 15.4. Bridge Girder

The steel box girder shown in *Figure 15.9* is the main load carrying element of the bridge. The octagon girder is 5.5 meters high and 15.9 meters wide. The free height below the girder down to the waterline is 5.5 meters allowing for passage of small boats.

The plate thicknesses vary from 14mm to 20mm. The plate stiffeners are traditional trapezoidal shaped and they are spanning in the longitudinal direction of the girder. The stiffeners are supported by cross frames with center distance of maximum 4.5 meters. At the supports on the pontoons bulkheads were used instead of cross frames as the loads in these section were significant larger than in the cross frames. The plate thickness in the bulkheads vary from 8 to 50mm. The box girder was constructed in straight elements with lengths varying from 35 to 42 meters. The elements were welded together with a skew angle (1.2 - 1.3 ) for accommodation to the arch curvature in the horizontal plane.

The cross sections dimensions of the girder are unchanged in the whole length of the bridge. Plate thickness and stiffener dimensions are not altered in any part of the

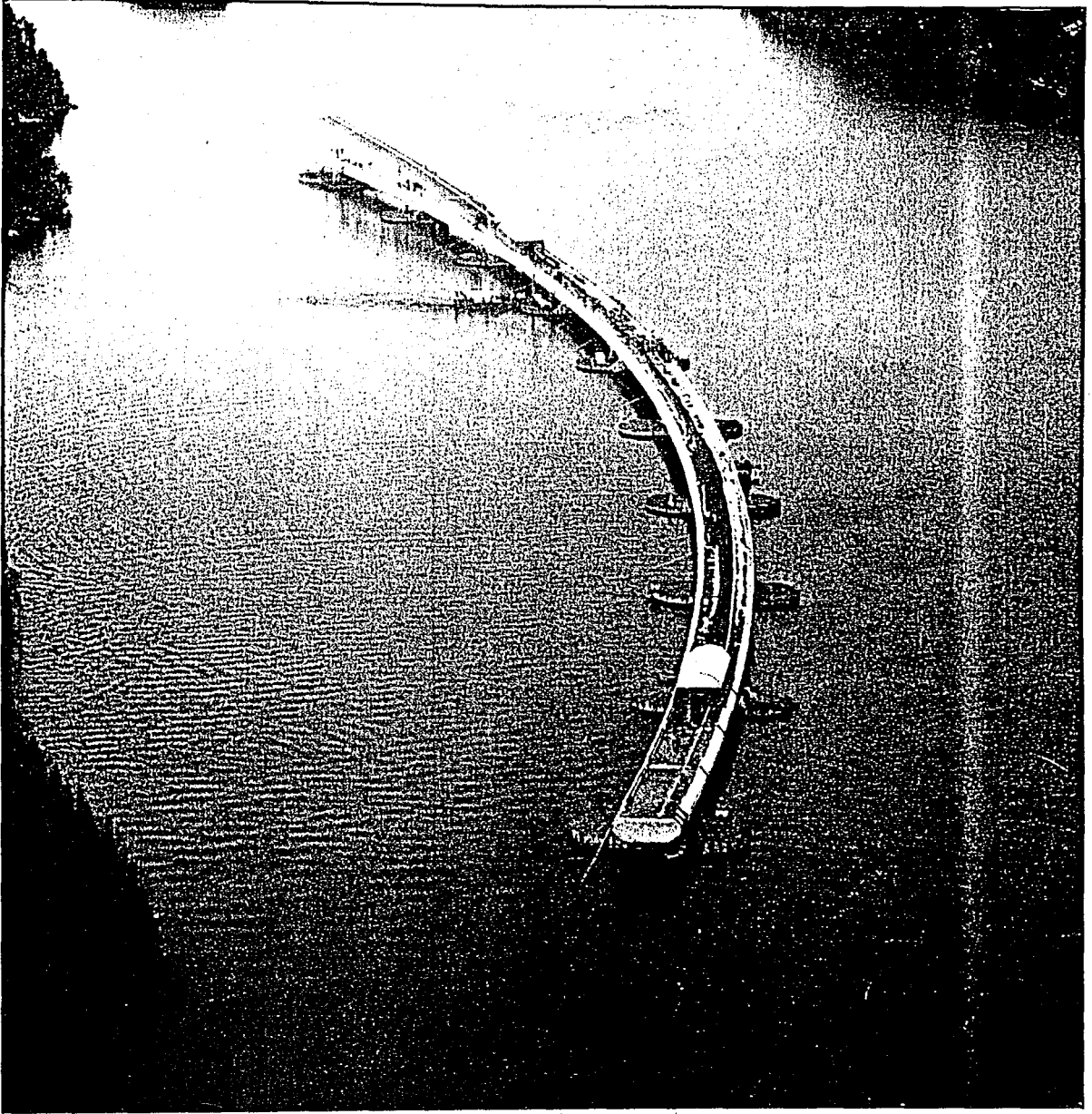

**FIGURE 15.7. SALHUS FLOATING BRIDGE, NORWAY** (Courtesy of G. Brekke, 1994)

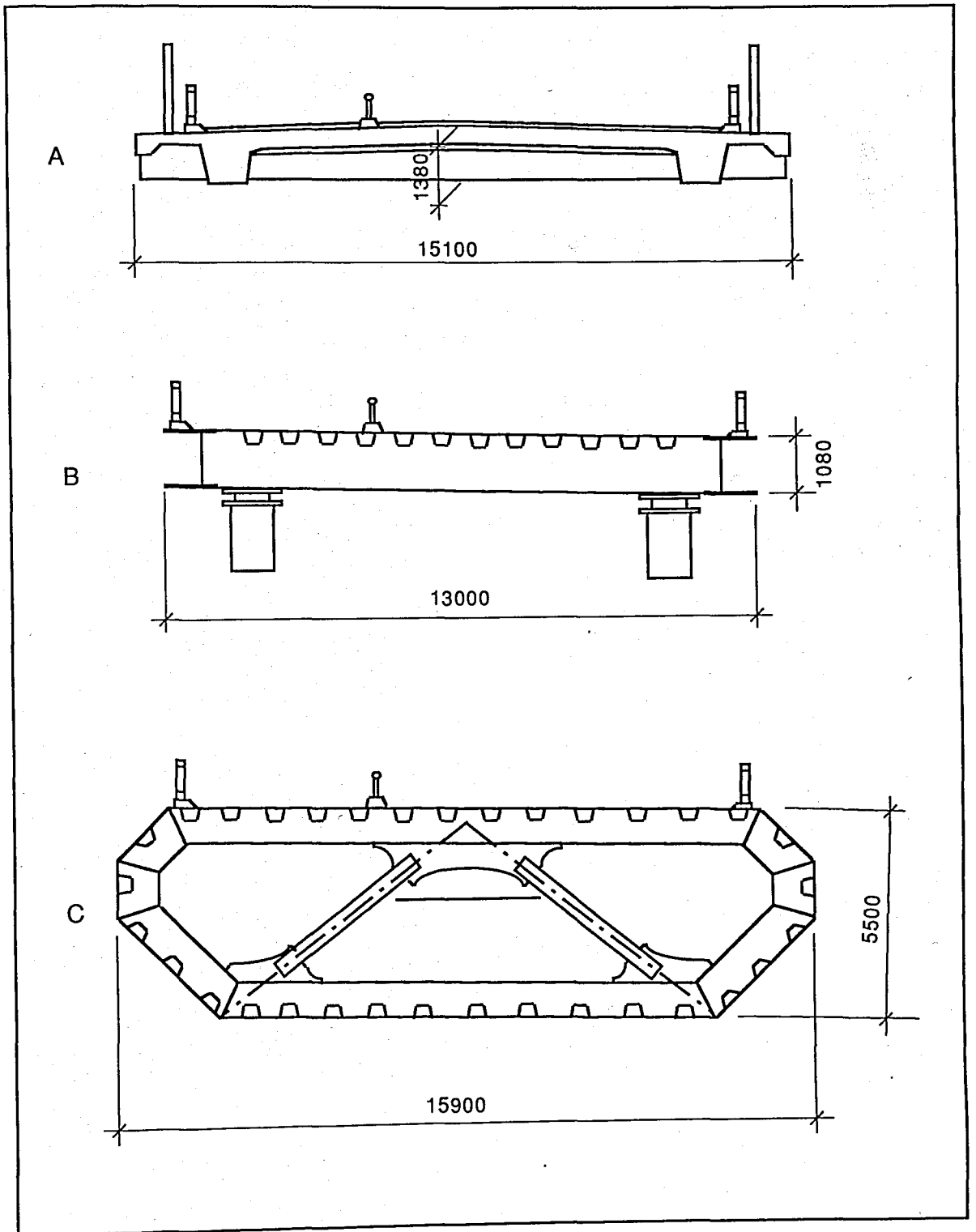
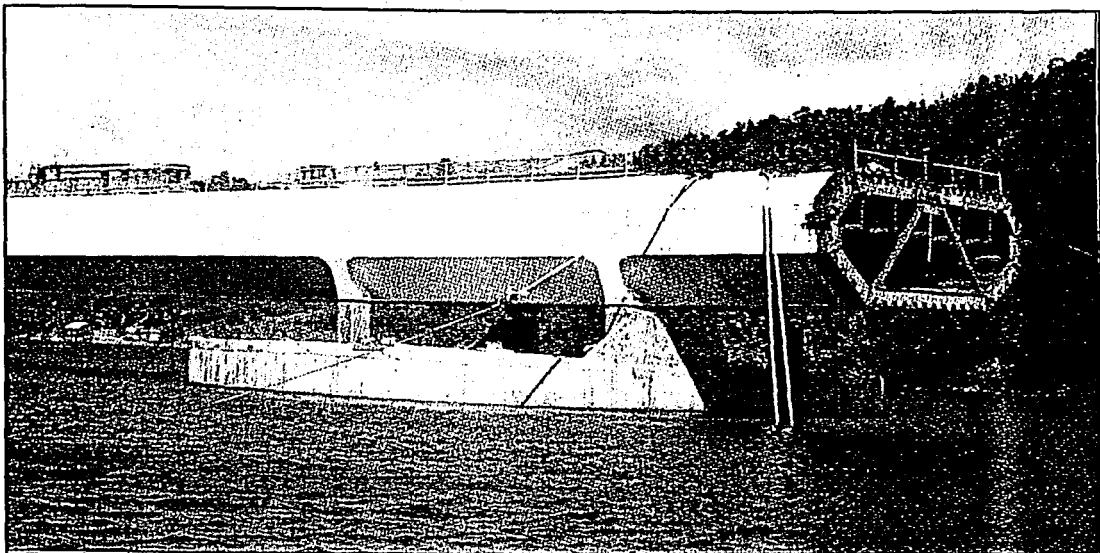

FIGURE 15.8. CROSS SECTION (In mm)



**FIGURE 15.9. THE STEEL BOX GIRDERS** (Courtesy of McGraw-Hill, 1994)

bridge, except for local strengthening at the connections to the pontoons and to the abutments.

The stress level varies significantly over the length of the bridge. The stress level is considerably higher in the area from the abutment and past the first pontoon than in the remainder bridge. This due to the tide and the fixation of the arch in the horizontal plane. In the areas with the highest stresses, steel with a yield stress of  $R_{eH} = 540$  MPa was used. In the remainder bridge, in cross frames and in bulkheads normalized steel with yield stress of  $R_{eH} = 355$  MPa was used [25].

The dimensioning load combinations in the ultimate limit state include dead load, temperature and environmental loads with return period of 100 years. Wave load is the dominant loading effect for the box girder, but also dynamic wind load and tidal variations have significant effect on the total stress level. The stresses caused by sea current load were found to be insignificant. The traffic load is not decisive for the main dimensions of the girder because traffic load shall be combined with environmental loads with a return period of 1 year. The stress level for environmental loads with return period of 1 year is significant less than for loads return period 100 years.

On of the most difficult design criteria to meet was the maximum allowed acceleration level in the serviceability limit state. In the development of the concept the cross sectional area of the girder had to be increased by approximately 10 per cent in order to reduce the vertical acceleration to the required level of  $0.6 \text{ m/s}^2$ .

The total steel weight of the box girder is 12500 tones of which approximately 3000 tones are high strength steel.

## 15.5. Elevated Ramp

The elevated ramp shown in *Figure 15.10* is approximately 350 meters long and have an inclination of 5.7 per cent [25], [26]. It conducts the traffic from the cable stayed bridge over the ship channel and down on the box girder.

The elevated ramp was constructed with a orthotropic plate-deck. The plate is 12 mm and is provided with 8 mm and 10 mm thick trapezoidal stiffeners. The stiffeners are supported by 800 mm high T-shaped cross beams with a center distance of maximum 4.5 meters. The main beams are located one at each edge of the ramp in order to maximize the stiffness about an vertical axis. The overall height of the main beams are 1200 mm. The lower flanges are 45 mm x 900 mm and the upper flanges are 50 mm x 610 mm and the web thickness is 20 mm.

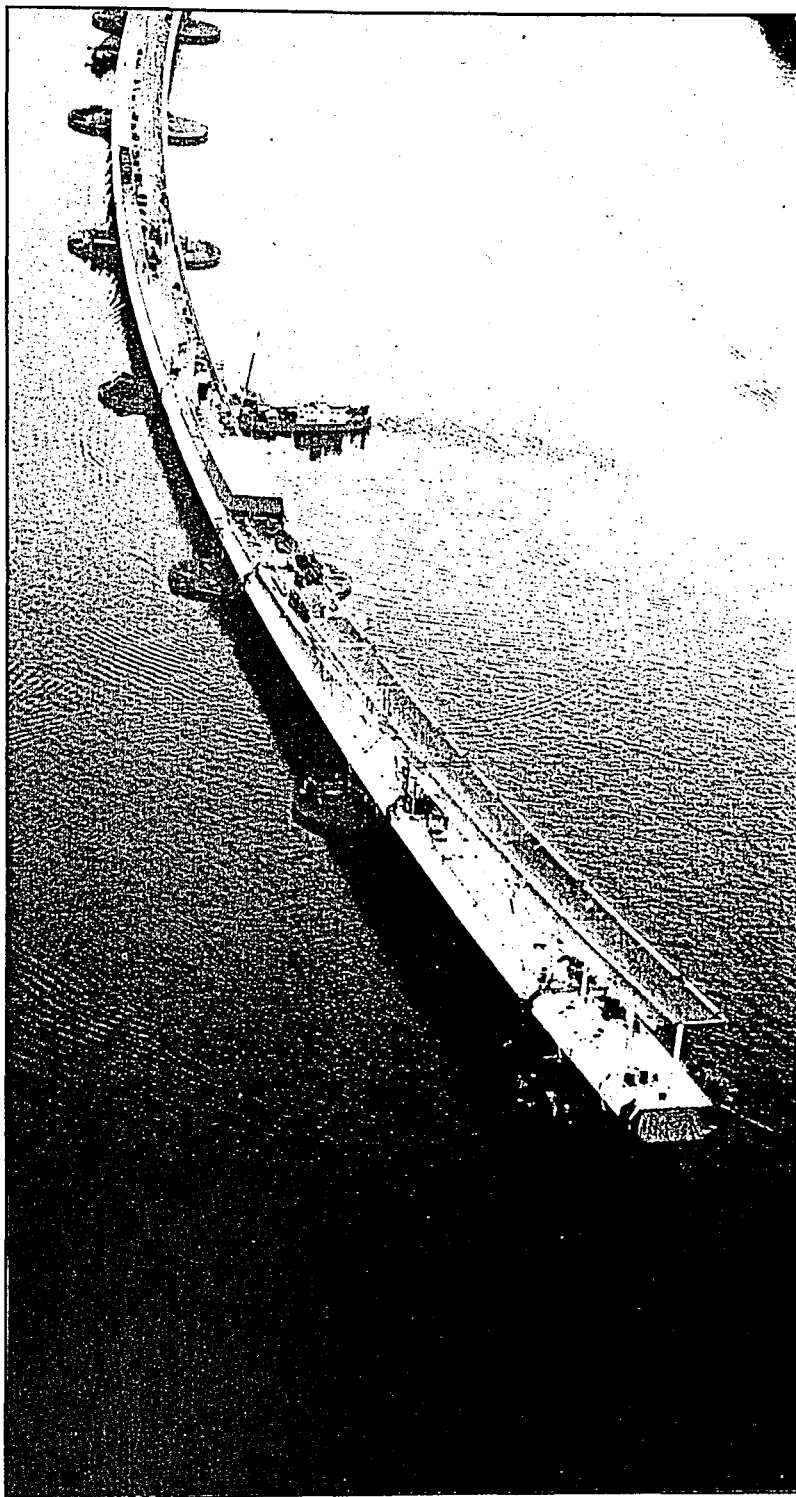

**FIGURE 15.10. THE ELEVATED RAMP**  
(Courtesy of G. Brekke, 1994)

In the horizontal plane the ramp was constructed in 35 and 42 meters long strait elements as the box girder. It is supported by pin ended columns. The span width of the ramp varies from 18 to 33 meters.

The columns are circular pipes with diameters ranging from 610 mm to 1000 mm. The columns have generally a low stress level.

The ramp is fixed in the longitudinal direction at the connection to the box girder (350 meters from the abutment). Laterally it is fixed in four sections, at the abutment and at the connection to the box girder. It is also fixed at two intermediate sections where trusses transfer lateral loads down to the box girder. In these two sections there are introduced hinges in the ramp about both a vertical and a horizontal axis perpendicular to the bridge. This is due to the necessity of reducing the accelerations in the horizontal direction. The hinge was provided by means of two bridge bearings located in the joints of the main beams, one fixed bearing and one bearing free to move in any horizontal direction.

The minimum yield stress for the structural steel is  $R_{eH} = 355$  MPa. The steel weight of the ramp is 1600 tones.

## 15.6. Concrete pontoons

All of the 10 pontoons, shown in *Figure 15.11* and *Figure 15.12*, are 4.0 meters long, 20.5 meters wide and with a half circle of diameter 20.5 meters at each end. The freeboard for the pontoons is generally 2.6 meters. This freeboard is designed such that there will be no flow of water on top of the pontoons under severe storm conditions. As the tidal variations had an effect on the freeboard of the pontoon near the abutment at each end of the bridge, the freeboard was increased to 3.0 meters for these pontoons. The draft varies from 4.3 to 5.6 meters. The variations are mainly due to the elevated ramp at one part of the bridge and that the end span is equal in length with these in the middle.

Each pontoon was provided with some solid ballast. This was not necessary for stability reasons, but was only used to account for uncertainties in actual weight after construction.

Each pontoon is divided into 9 compartments which are separated by watertight bulkheads. Each compartment has access through a watertight hatch from the top deck. The size of compartments are determined such that the floating bridge is still intact if two adjacent compartments are flooded due to some accident.

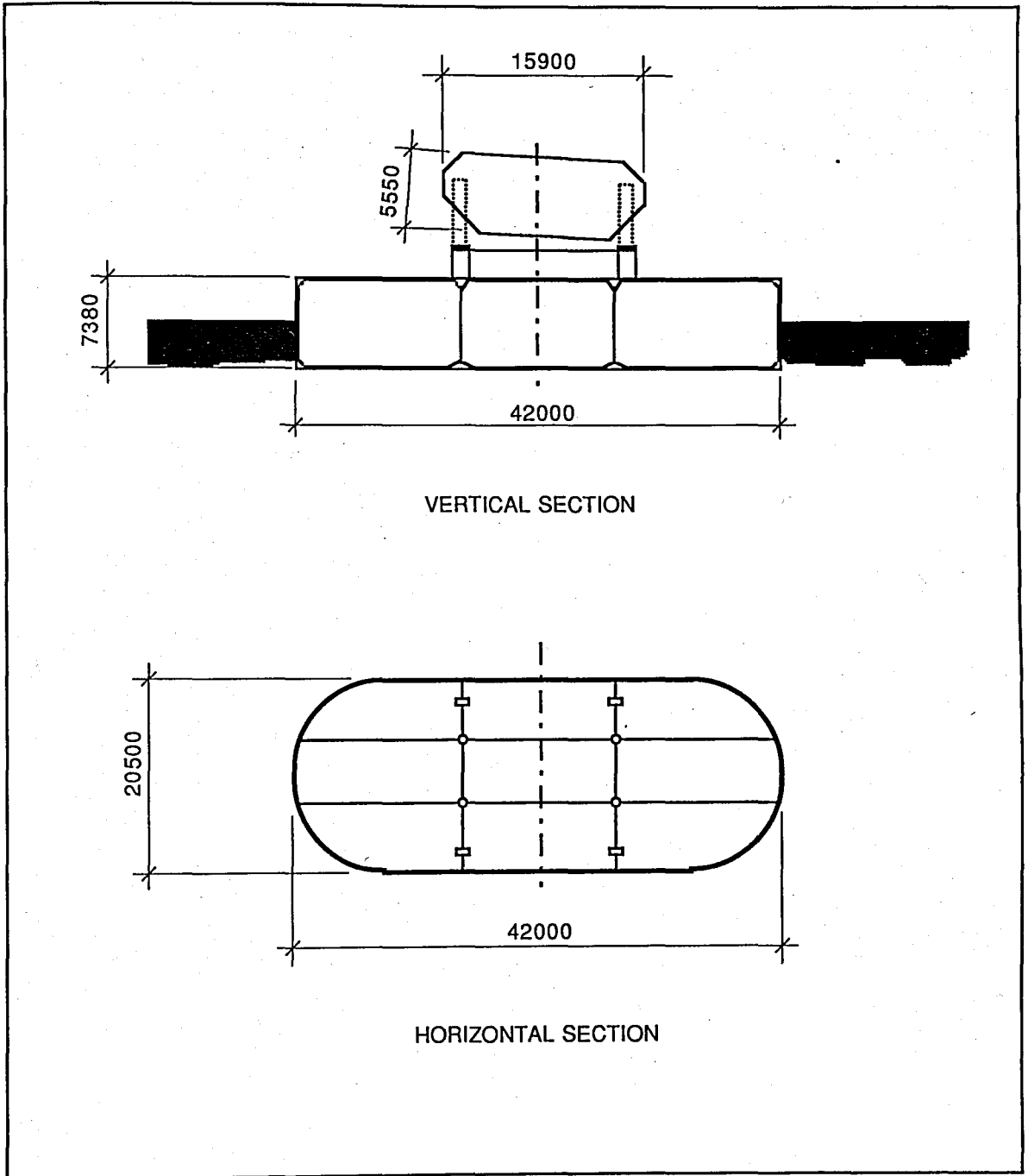
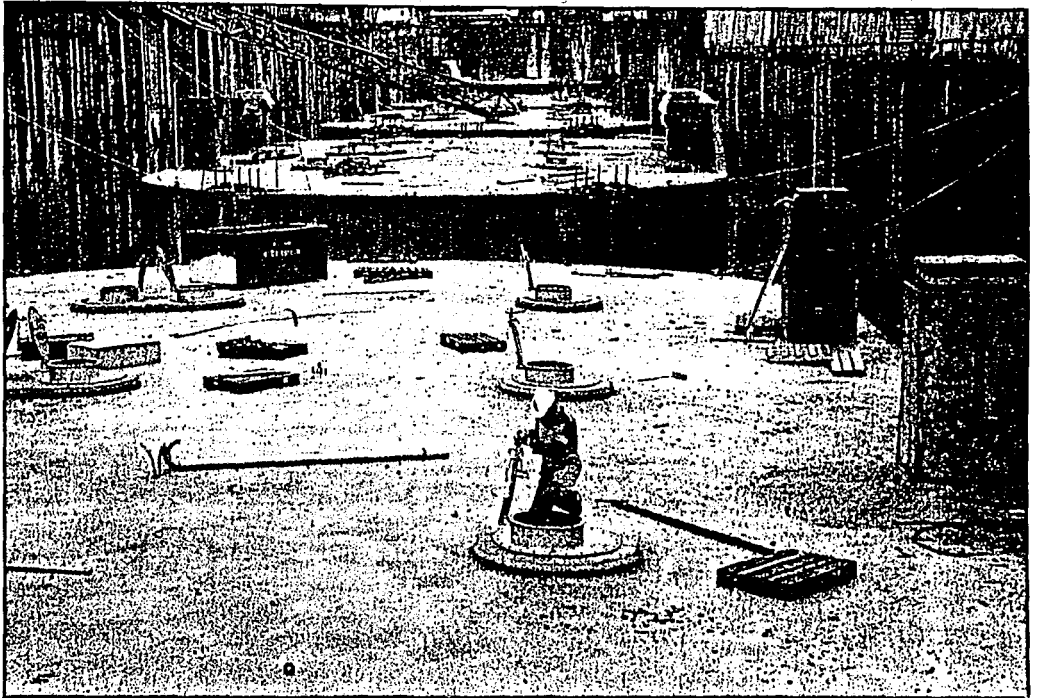

FIGURE 15.11. PONTOONS PLAN AND SECTION (In mm)



**FIGURE 15.12. THE PONTOONS** (Courtesy of G. Brekke, 1994)

The thickness of the bottom slab is 300 mm, the outer walls are 310 mm thick while the top slab and the internal bulkheads are 200 mm thick.

Light weight aggregate concrete, LC55, was used in the entire pontoons in order to minimize the weight. A reduction of weight was favorable because the draft was reduced which again reduced wave and current loading on the entire structure. The savings were therefore mainly achieved by reduction in the structural steel weight.

The main properties of the LC55 concrete are [25], [27]:

- (a) E-modules: 20000-23000 MPa
- (b) Density (saturated) is maximum: 1950 kg/m<sup>3</sup>
- (c) Type of aggregate: Liapor 8

The most critical design criteria are those valid for the Serviceability Limit State:

- (a) The minimum height of the compression zone in any cross section shall be at least 100 mm in order to ensure water tightness.
- (b) the crack width shall be less than 0.2 mm in the splash zone and less than 0.5 mm otherwise.

Although the floating bridge as such is a dynamically sensitive structure, the governing loads on the pontoons are mainly the effects of hydrostatic water pressure in combination with selfweight of the bridge.

The steel box girder is supported on 4 pedestals on the pontoons. These supports are provided with modified normal bridge bearings. In order to minimize the loading due to differential horizontal deformations at the supports, two bearings are free to move horizontally while the two others are fixed. The two fixed bearings are placed diagonally opposite of each other.

## 15.7. Connection to Abutments

The steel box girder is fixed to the abutments by means of special purpose made "flexible" plate connections made in high strength steel [25], [28]. The plate connections transfer bending moments about a vertical axis, axial forces and horizontal shear in the girder to the abutments. The plate connection however, are flexible about a horizontal axis perpendicular to the bridge in order to allow deformations due to tidal variations. Vertical shear and torsion is taken by separate neoprene bearings. On each side of the steel girder it is one set of neoprene bearings supporting downward vertical forces and another set supporting upward vertical forces.

The flexible plate connections were forged in order to obtain excellent fatigue properties and a high yield stress,  $R_{eH}=500$  MPa. The thickness of the flanges and transition curvature between the plate and flange is designed in order to minimize stress concentrations.

The steel plate connection elements were fixed to the steel girder by means of bolts, shown in *Figure 15.13*. The bolts were specially made for this project. The diameter of the bolts are 82 mm and they have a proof stress of 940 MPa.

The fixation to the abutment was provided with 32 tendons in each abutment. Each tendon has 37 No. 15 mm strands and was tensioned to 7.35 MN. The tendons are short; 10.3 meters and 12.8 meters respectively. Tension losses were therefore calculated. In order to provide sufficient compression stress capacity behind the steel connection elements, thick steel foundation plates were used to distribute stresses, and concrete quality C75 combined with a dense reinforcement was used at least 2.5 meters behind the foundation plates.

The flexible plates were bolted to transition elements, which were welded into the box girder. The transition elements were forged and the final heat treatment was by normalizing. The yield stress of the transition pieces are  $R_{eH} = 320$  MPa. The chemical composition was determined in order to get good weldability and uniform mechanical properties.

## 15.8. Abutments

The abutment from the transition between the high level bridge and the floating bridge. This abutment is founded on bedrock at a water depth of 30 meters. It consists of a caisson with a cross section of 20 x 21 meters with 16 internal cells. The caisson was filled with gravel and it was closed with a slab 5 meters above the water line. On top of this slab massive anchor blocks were arranged to provide fixation of the floating bridge and to provide foundations for the columns of the T-structure that supports the high level bridge and the ramp [25].

Due to the large height of the caisson it was designed such that the lower part, 12.5 meters high, could be constructed in a dry rock and the upper part could be constructed by slipforming in floating condition. This construction process is the same as used for concrete offshore platforms. All marine phases were checked with respect to hydrostatic stability. As part of this design all walls were designed such that any compartment could be accidentally filled during construction without loss of the structure.

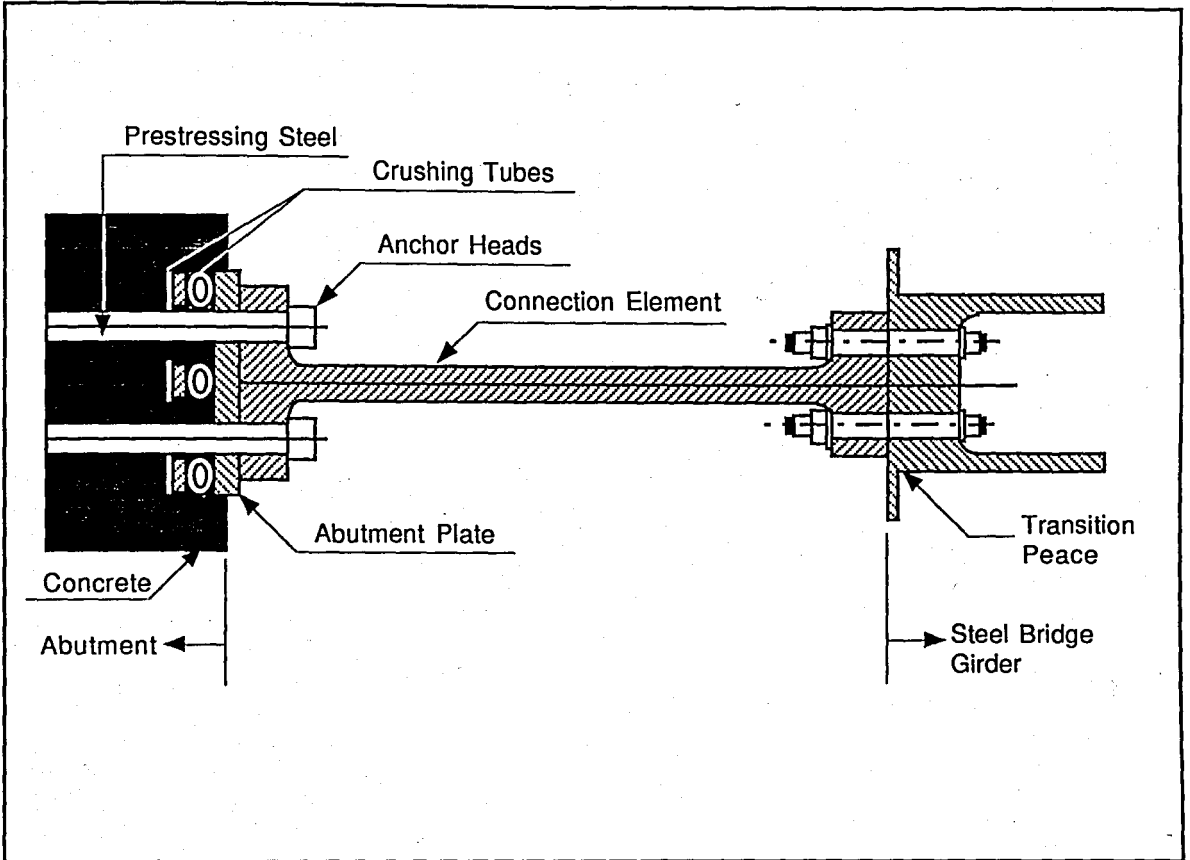

FIGURE 15.13. DETAIL OF FLEXIBLE PLATE CONNECTION

The bedrock at Klauvaskallen was leveled by blasting. A massive foundation plate was constructed by underwater concreting. The caissons are supported at three points on this foundation leaving a space of about 100 mm between the foundation and the underside of the caisson. This space was grouted by means of pumping of concrete from one single pipe in the center of the caisson. A certain roughness of the underside of the caisson and top of foundation was arranged to secure sufficient friction for transfer the horizontal forces that will occur.

The other abutment was placed on land. This consists basically of a massive concrete block which is 22 meters long, 20 meters wide and 14.5 meters high. This block was cast in place directly against blasted rock surfaces.

The largest loads to be carried by the abutments are axial forces in the box girder in combination with a moment about the vertical axis of the abutment. Vertical prestressed rock anchors are required to provide sufficient stability. In one abutment 12 tendons were used, and in the other 14 tendons. The total tension force is approximately the same; 42 MN to 44MN. The size and weight of the abutments are designed such that they are stable also without rock anchors, but then reduced load factors are applied.

## 15.9. Instrumentation

A comprehensive instrumentation system was installed on the floating bridge for measurements of environmental loads, the structure's response to these loads and for operational monitoring. The purpose of the instrumentation is to collect data for verification of the basis for the structural design, and operational control. Instrumentation for the measurement of the following parameters was installed [25], [29]:

- (a) Environment : Wind speed and direction, wave height and period, tidal water level, air and sea temperature, hydrostatic pressure on outer pontoon wall.
- (b) Response: Strain in bridge box sections (8) and in flexible plate connections (64), linear (6) and angular (3) accelerations in bridge box sections.
- (c) Corrosion: Electrical resistance probes, resistivity probes and reference electrodes have been cast into the concrete in two pontoons.
- (d) Operation: Open/closed status for hatches in all pontoons and doors in the box, alarm switches in all pontoon compartments, water level switches in all pontoon compartments, collapse of the bridge structure, monitoring of dehumidifier, main fuses and radar beacon. The data acquisition system is based on five local acquisition units spread along the floating

bridge. The units communicate via a common data bus with a PC based acquisition and storage system situated in one of the bridge abutments.

The system acquired data from the total of 132 sensors at a sampling rate of 4Hz and stored the raw data on magnetic tape in the form of 20 minutes sequences. Basic statistical data, i.e. mean, maximum and minimum values together with the standard deviations were calculated for all sensors and the results stored in separate files.

The basic statistical data was calculated and stored every 20. minutes. The frequency of raw data storage was determined by the measured wave height: For significant wave height below a low limit, raw data was stored once per day. For significant wave height above the low limit, but below a high limit, raw data was stored every three hours. For significant wave height above the high limit, raw data was stored every hour. For each sensor alarm limits could be specified. If one of these was surpassed, the data acquisition system was activated also outside the routine.

A selected set of statistical data and alarm messages was transferred to the road office's operational center. There was no automatic control functions incorporated in the instrumentation system.

## 15.10. Installation

The bridge site was 7 nautical miles from the fjord where the assembly of the bridge had taken place. The bridge was towed to the site by two powerful tugs. To ensure good maneuverability three tractor tugs were placed alongside three pontoons, at right angles to the center line of the bridge [27].

When the bridge had been turned and floating parallel to the line between the two abutments, preparations were made to slide the end into the abutment at Klauvaskallen. When the end had entered Klauvaskallen, the other end was swung sideways into the abutment at Flatoy through a prepared recess in the side wall of the abutment. The tide was right to do this operation. Compensation for tide was done by ballasting/deballasting of the barges where the two ends of the bridge were resting. The next stop was to lower the ends of the bridge on the bearings at each abutment.

The flexible plate connection, the link between the steel bridge and the concrete anchor blocks, allowed for virtually no tolerances between the concrete abutment and the base plate of the flexible plate connection. Thus a method from the offshore platforms, developed by Norwegian Contractors, had been utilized.

This method consists of crushing tubes or tubular bearings (thick walled tubes) welded on to steel plates and cast into the wall of the abutment taking up tolerances by deforming.

When the base plate of the flexible plate connection was in contact with the tubular bearings, a fix number of the tensioning cables holding the base plate (i.e. the bridge) to the abutment were stressed to 100 per cent of their force.

The characteristics of the tubular bearings were such that they would reach yield point and deform, in this case approximately 50 mm. the tension force in the cables were then released to 50 per cent and the gap between the concrete abutment and the base plate was filled with concrete.

After the concrete had reached the proper strength all tendons were tensioned up to 100 per cent. After the bearing between the top of the steel box and the concrete was installed, the bridge was secured.

## 16. IMMERSED TUBE TUNNELS

### 16.1. Introduction

For the construction of tunnels a number of techniques are available. Compared to bored tunnels, immersed tube tunnels have a number of advantages. The construction time can be shorter, the risk in terms of time and cost overruns can be less. Delays can be neutralized by acceleration, additional equipment, etc. which is difficult or even impossible with bored tunnels [30].

The construction of immersed tube tunnels shows a considerable increase worldwide. The number of parties involved increases herewith. This means, that many of the technicians involved are not anymore aware of the specific implications of this technology. Old applications are just copied without knowing the background and criteria. This leads to an increased risk of accidents, delays and cost overruns.

The construction techniques are very much influenced by the specific environmental conditions and requirements of the project. This means, that great care has to be given to the investigations and survey of these environmental conditions, such as the hydraulic conditions, the weather conditions and geotechnical conditions.

Dredging and backfilling of a trench is an essential part of the construction of immersed tube tunnels. The effects on the environment may lead to a temporary change in the ecological and biological conditions on the site or even elsewhere. These effects can be positive but negative as well. Anyhow the impact can be controlled by proper preparations and a intelligent selection of dredging techniques adapted to the circumstances and criteria. On a number of recent projects the presumed contaminating effects of the dredging have lead to the choice of bored tunnels accepting higher risks in time and cost overruns.

So called unforeseen conditions caused delay and cost overruns in a number of recent immersed tube tunnel projects. Could these have been foreseen and properly implemented in the design and construction? It all relies on skills, experience and know how. This would depend on the collection of required data and above all, proper judgment and implementation of these data.

Availability of sufficient data, techniques and skilled personal is an additional factor to be successful, supported by a good organization and communication. Whatever the legal and contractual relationships between parties involved are, the organization on the site must be direct and open. All main parties involved should have access to relevant information and should have an input in the decision making.

When the guidelines are properly followed, this will lead to a successful operation for all parties involved, resulting in less cost and time overruns.

The construction of immersed tube tunnels is possibly one of the most fascinating civil engineering involvements, due to a wide variety of construction techniques, that has to be used and the many external conditions that will be faced.

The construction of concrete or steel tunnel elements of high quality and accuracy, the precise dredging, the preparation of the foundation and a number of sophisticated marine operations for placing the tunnel elements require professional skills of the engineer, sophisticated equipment and experience. The construction techniques to be used often have an important effect on the design of the tunnel.

Every project is unique and no general rules can be given. For the principle this work will give an idea about the problems, that may have to be faced and therefore has to be considered. Mainly used and experienced techniques are mentioned. The techniques are related to immersed tube tunnels.

Within the scope of this work to make a judgment of the various techniques is impossible. Judgments can only been made, when all conditions, criteria, requirements, etc. for the specific project are known. A preference for a specific technique may lead to the wrong conclusion for a project.

## 16.2. Characteristics and Types of Immersed Tube Tunnels

### A. Concrete Tunnels

We can define two different types of immersed tube tunnels. The concrete tunnels found their roots in Europe. Over half a century ago the first European immersed tube tunnel was built in Rotterdam. Since then the construction methods have considerably been simplified and optimized. Now about 36 concrete tunnels have been built all over the world but the most of these tunnels are built in Europe [30].

The main principle of a concrete tunnel is that the tunnel elements are made of reinforced concrete which serves for structural purposes as well as for ballast. Although most of these tunnels recently built do not have a watertight membrane any more, older tunnels and a number of recently built tunnels for different reasons still have a watertight membrane of steel or asphalt bitumen.

Most completed concrete tunnel elements consist of a number of segments with limiting length of about 20 -25 meters long. These segments are linked together with flexible joints. Thus each segment is a structural entity which makes it easier to control the concrete placement and to limit the structural forces in the elements. There are a few concrete tunnels with stiff tunnel elements.

### B. Steel Tunnels

In the beginning of this century the first steel tunnels have been built in Northern America. Steel tunnels are designed as composite structure with steel and concrete. The steel serves as a watertight membrane and has a significant structural contribution. The concrete primarily is used to take compression forces and as for ballast purposes, also contributing towards structural requirements.

Completed tunnel elements form a monolithic structure, with some flexibility due to the elastic characteristics of steel. All together 33 of this type of tunnels have been built all over the world but mainly in North America.

Apart from the techniques required to construct these elements, the marine techniques will require different approaches. These differences had to do with the principles of the different materials as well as with the contractors techniques developed independently from each other in the different environment.

### C. Comparison

Until recently the concrete and the steel options were considered to be different worlds divided by the Atlantic Ocean. One cannot simply say, that steel is more expensive than concrete. For a proper comparison all aspects will have to be considered.

Each application has a different impact on the time schedule, the construction of the approach ramps, the casting yard and/or fabrication yard, etc. Time for instance will be of importance in case of a privately financed project. This may even result in the acceptance of a higher direct costs.

Environmental requirements may increase the cost of a specially constructed casting yard for concrete tunnel elements, which may lead to a steel tunnel solution. The length of the immersed part of a tunnel may be more with a steel tunnel than with a concrete tunnel, thus shortening the in situ approach ramps, which may influence the overall comparison.

The reason for a different American and European approach may have its roots in scientific and political developments. However, in general terms history has proven, that the end result in terms of quality, watertightness, lifetime, reliability, maintenance, etc. in general terms do not differ. It is only recently, that two different types were confronted with each other and compared in a proper way.

The future will show whether a combination of the existing techniques will lead to a better optimization.

### D. Tunnel Depth

Tunnel depth under a navigable waterway is determined by [31]:

- (a) depth of channel and any intended dredging to greater depth;
- (b) depth of protective cover over the crown of the tunnel;
- (c) roof thickness;
- (d) headroom above the running surface or other design datum;
- (e) construction depth below the running surface.

*Figure 16.1* shows the comparative depths required for tunnels of similar function but differing forms of construction.

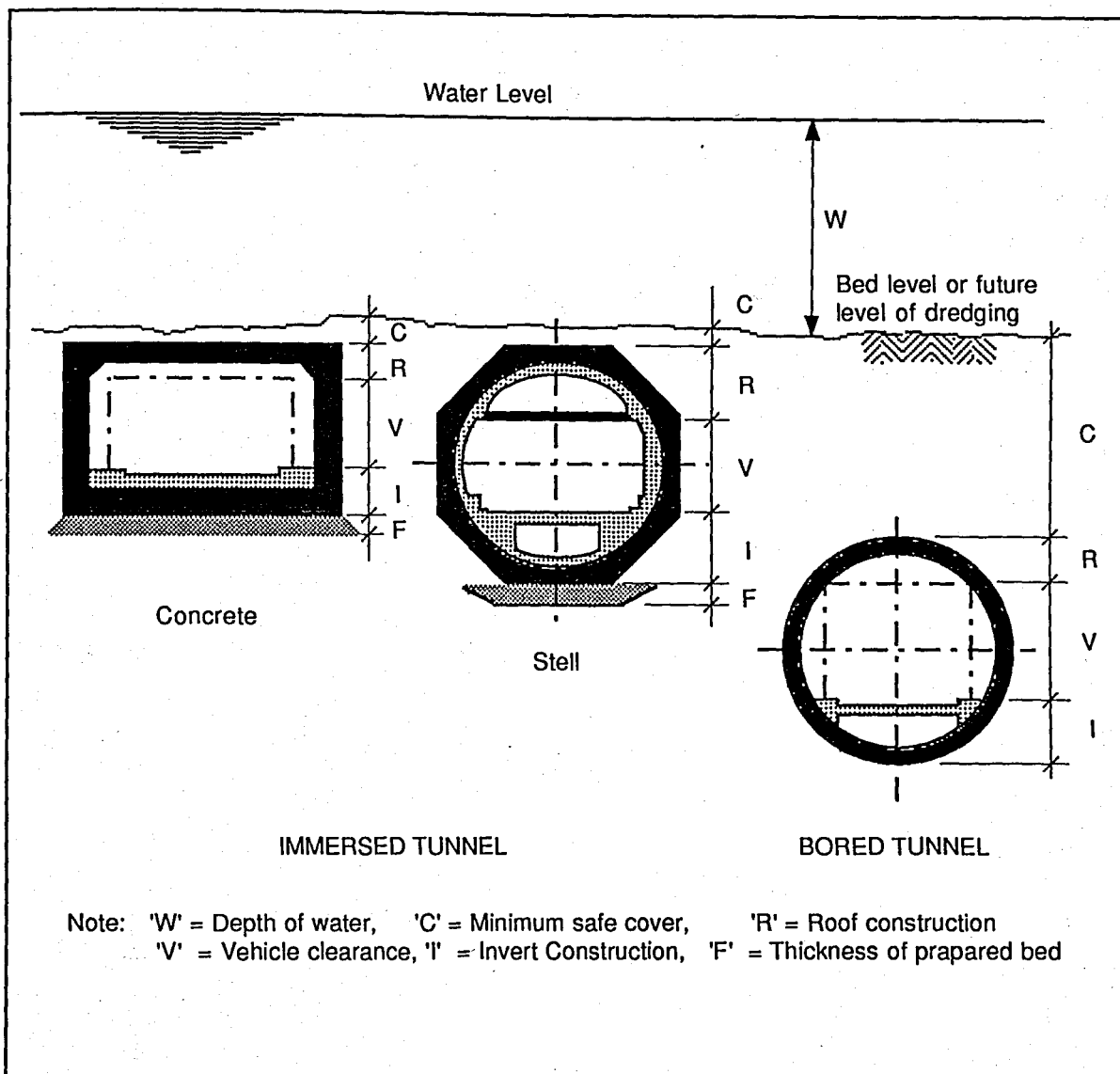

FIGURE 16.1. COMPARATIVE DEPTHS REQUIRED FOR TUNNELS

### 16.3. External Aspects and Conditions Impacting the Construction Methods

External aspects and environmental conditions are of major importance for the design and construction of a tunnel. One has to know as much detailed as possible, what conditions can occur. Moreover one has to follow and predict these conditions in various phases of the execution of the project to avoid unforeseen and nasty situations [30].

Therefore it is essential to collect and properly judge the data available and to be sure, that these data will be registered and reported during the various phases of the project. Depending upon the specific conditions these data have an impact on the methodology and in many cases can be decisive for the method, equipment and timing of the various activities.

Example of a scheme reflecting what is meant above is shown in *Figure 16.2*.

#### A. Hydraulic

##### A.1. Data collection-methodology

The collection of data depends upon the local conditions, the specific requirements of the project and the available information. Many tunnels are being made in the areas where much information regarding the specific hydraulic conditions is available. It is desirable to have long term information (5-10 years). The more is known the smaller the chances of unforeseen events are.

In addition to that, it requires experience and skills to know what information is critical or vital, what information is important and what information could be of use and how to deal with this information. It depends upon the specific requirements of the project. For instance the transport of a tunnel element over sea requires a different approach than a transport over inland waterways. The immersing in a river can be entirely different than in a canal. Tidal influences may create opportunities but threats as well.

The level of detail of the information can also result from the views of the contractor about the methodology and equipment used. In general one can say that it is wise to design the working method and its equipment in such a way that it contains extra capacity in order to overcome unforeseen circumstances.

Problems with tunnel projects in the past often resulted from insufficient information judged by unskilled personal.

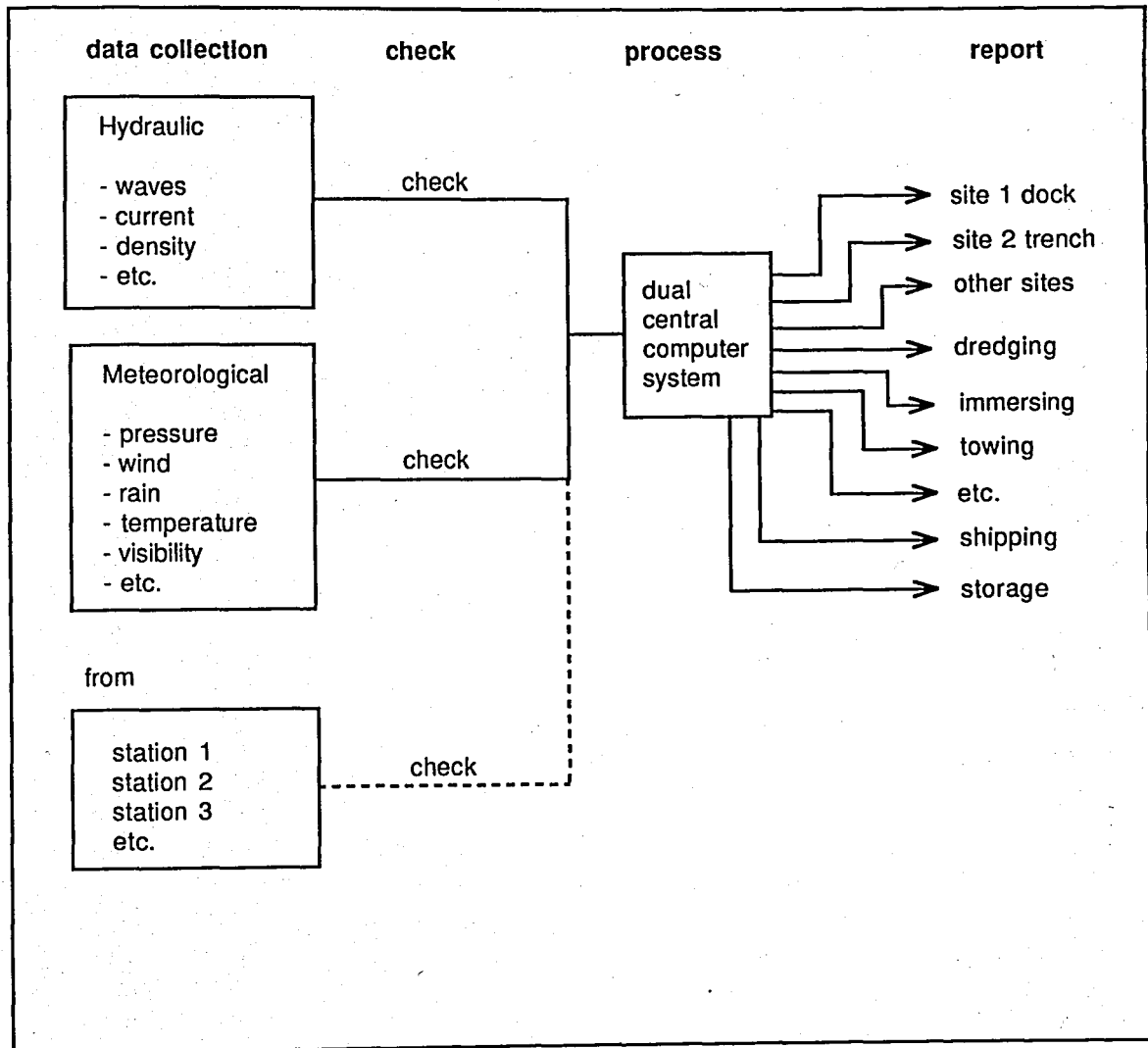

FIGURE 16.2. SCHEME OF DATA COLLECTION

It has often been seen that unforeseen conditions did occur which cost the client and/or the contractor a lot of money. In many cases these unforeseen conditions could have been avoided, when skilled specialists were involved in an early stage of the project to evaluate the conditions.

In the following, marine conditions of influence on the construction techniques and subsequent on the design are summarized. This listing can be used as a checklist. But one has to be aware of possible specific conditions in the area.

## **A.2. Current - velocity and the directions**

The main influence of the current regards the towing and construction technique related to the immersing itself. The tunnel element to be towed and immersed is exposed to the current. The forces resulting from the current have to be taken into account to keep control over the tunnel element. These forces are the outcome of the current velocity, the shape and size of the tunnel element and the width, depth and shape of the river or current effected area. In the past these forces were predicted by performing tests in hydraulic laboratories and in many cases still are.

If the conditions at hand are not too different from past experiences the forces can be estimated based upon the past experience. Current velocity and available space for maneuvering are often limiting factors for the length of tunnel elements. Tunnel elements of 280 meters long have been immersed in canals with hardly any current. Experience learned shows that tunnel elements should be limited to 140 meters with current velocities up to 1.5 m/sec. A tunnel element of 120 meters long requires special procedures.

The direction of the current is an important factor. During the take over from transport phase to the immersing and other manoeuvres a very precise and good prediction of the current behavior is required. In many cases it is advised to set up a system which measures the current velocity and registers the current directions during the marine operations.

## **A.3. Specific gravity**

The handling of huge tunnel elements is very often controlled by the availability and use of local possibilities, equipment and know how. Tunnel elements of more than 45.000 tons have been built and transported to be immersed at a far away place. This could only be done by making use of the buoyancy caused by the water.

The design of a tunnel is directly related to this principle. It is therefore important to know the specific gravity precisely. But the specific gravity can change over the time,

place, depth, sedimentation and temperature. It will not always be possible to be entirely sure about these variations. In that case one has to decide upon a margin.

There can also be a seasonal variation in the specific gravity. This may be the result from changes in temperature as well as from the sedimentation which may vary per season.

Differences in specific weight for fresh versus salt water could be critical with respect to the place. This of course depends upon the location either at or close to the sea or inland. However, this does not mean that inland water is always fresh.

The heavier salt water goes inland depending upon the local conditions, the quantity of water coming from inland, the water level at sea, etc. All these matters are very much influenced by the meteorological conditions. In some cases it might be good or even can be required to know the relations between the meteorological and hydraulic conditions.

The specific gravity will vary over the water depth as well. This can be caused by a number of matters. The temperature can vary over the depth. The heavier salt water will be near the bottom and the fresh water will be at the surface. There can be a complicated system of current.

So far specific gravities ranging from 0.9850 - 1.003 have been experienced in various projects on different locations or even at one and the same project but varying over the time.

#### **A.4. Tidal effects**

The influence which tidal effects can have on the current velocity is already mentioned. Tidal effects also cause differences in water height. These can be of influence for the choice and or design of the casting yards. But also the transport over water ways in relation to water depth are influenced by height of the water. As is the immersing procedure. The length of the immersed section is influenced by the tide and with the water level.

There can be an optimum period over tidal differences ranging from spring or neap tide. At spring tide the height of the water can be maximum ( and minimum as well), at neap tide the current velocity will be lower. This may lead to a number of days with the best or required circumstances for the marine operations. This periods are called the tidal windows.

### **A.5. Waves, swell and surf**

In many cases tunnels are built in relatively protected areas. Here the waves hardly have any effect on the tunnel elements. The effects of waves going over the tunnel element during the various operations have to be taken into consideration in the towing and immersing steps. However, under relatively exposed conditions offshore for transport and/or immersing of tunnel elements the effect of waves and swell can be of much importance to the immersing operations and eventually the design itself. For immersed outfalls the surf will have to be taken into consideration as well.

Another aspect, that has to be considered is the own frequency of the tunnel element in relation with possible frequencies of waves or swell resulting from wind, offshore conditions and/or navigation. Especially when the tunnel element is moored at an outfitting quay at a vulnerable place, waves and/or suction from passing ships can have an enormous effect on the forces on the tunnel elements due to this phenomena.

### **A.6. Sedimentation**

Most rivers have their specific problems with sedimentation, silt, mudflows and/or transport of material over the bottom. This can affect the maintenance of the trench, the quality of the foundation and the quality and quantity of the ballast system to be installed.

Experience learned shows that the characteristics of every river with respect to sedimentation etc. are different and entirely depending upon the local situation. These aspects have to be considered in advance. If this is done and proper precautions are taken, sedimentation will not be a problem. These precautions concern cleaning of the trench and the system of placing of the final foundation.

The following gives a number of causes of sedimentation. In many cases a number of individual aspects along or together influence the sedimentation [30];

- (a) A sudden decrease of the current - velocity in the trench may cause the sedimentation of materials being transported by the faster following water.
- (b) Sediment, suspended in fresh water, will when mixed with salt water, flocculate and settle down on the bottom, forming a thin mud layer. Subsequent tides will deposit more layers on top and due to developing weight-pressure, consolidation might occur. Depending on the rate of this sedimentation and consolidation and on the number of tides during exposure of the dredged trench, the system and frequencies of trench cleaning can be adapted.

(c) In a waterway where high flows and high currents are existing, materials are potentially carried by bottom transport. Especially this material will settle readily in dredged trenches.

(d) Under certain conditions the activities for the project or in the neighborhood of the project can cause an increase in the sedimentation. For instance the placing of the foundation underneath the tunnel may effect the concentration of suspended sediment, etc. in the remaining part of the trench.

(e) The occurrence of mudflows, sedimentation, etc. in rivers in general can be foreseen. The quality and the quantity of this is difficult to predict. Specialists advice is important because these matters can be of major importance to the success of the execution of the project and the quality of the foundation.

#### **A.7. Other river and/or sea characteristics and obstacles**

Upon designing and planning of an immersed tube tunnel one has to carefully investigate the surrounding hydraulic conditions since each site may have another surprise.

With in the scope of this work only exceptional matters such as ice(bergs), seaweed, shellfish or even fish are mentioned. These matters may influence the location methods during the immersing operations.

#### **A.8. Hydraulic models**

Hydraulic tests in laboratory will give a lot of information in order to investigate and decide upon the effects of the hydraulic conditions on the construction methodology. This allows us to estimate the forces on the tunnel element and to forecast the behavior of the tunnel element in the specific conditions of that site even without performing tests.

### **B. Meteorological Aspects**

#### **B.1. Data collection-methodology**

The weather conditions normally have an effect on the marine conditions and they have to be taken into account. The weather conditions can also have an important effect on the marine operations directly. Too much wind may be risky during the immersing. Lack of visibility may frustrate the location methodology of the operations. Ice may make it impossible to work with the equipment, ropes, etc.

The data collection in most cases is not a problem. In most parts of the world, where the construction of tunnels is being considered, long term weather conditions have been collected and are available. Not in all but in many of these places the influence of these weather conditions on the hydraulic behavior is known or can be known, when skilled specialists investigate and compare the data of the weather conditions with the hydraulic conditions. When this is not the case additional survey has to be done.

Also during the operations it is required to be well informed about the conditions occurring during the operations. The sensitivity of the marine operation methods and the eventual risks related to a delay and/or a sudden postponement of the immersing may even result in the conclusion to set up a weather forecasting station at the site. For instance, when a tunnel has to be built in a busy harbor, it might be worth to invest the conditions because every (unforeseen) hour of blocking of the harbor has its price.

## **B.2. Wind**

As mentioned before, wind can have a strong influence on the hydraulic behavior and on the operations, depending upon the equipment used. Wind has an positive effect on visibility.

## **B.3. Temperature**

The temperature might be a problem when it droops below a critical point in relation to the humidity causing poor visibility. When there is frost in relation with low temperature of the water, ice may occur on the equipment, anchor - and mooring lines and alike.

## **B.4. Visibility**

Poor visibility is one of the most difficult and unpredictable situations. It might frustrate the positioning systems. It is possible to make use of systems, even working under poor visibility conditions.

But the investment may be very high compared to the benefits. This depends upon the frequency of poor visibility, the number of tunnel elements to be installed, the risks and the results related to a delay or postponement of marine operations for the project itself as well as for the economic effects of a sudden delay or a postponement for the surrounding area.

## **B.5. Other meteorological matters**

Although most of the vital meteorological consequences have been dealt with, other phenomena specific to the site will have to be considered. It is always wise to talk to a local sailor or pilot. One learns a lot from this information.

Another aspect to mention is that local conditions may influence the accuracy of the positioning system used or may frustrate the communications. This can be the case with high and heavy steel structures in the neighborhood of the location and with high voltage electricity cables.

## **C. Shipping/Navigation**

### **C.1. Ship movements during the marine activities**

Most of the tunnels are built in waterways with heavy shipping. Hindrance of the marine operations to the shipping movements especially in busy shipping water ways has to be avoided or limited to the minimum. Possibilities depend upon the local conditions and requirements.

The marine operations effecting the ship movements are the dredging activities, the transport of the tunnel elements, the immersing and possibly the foundation and the backfilling. With the first design phase of the tunnel prior to the preparation of the tender documents, the shipping authorities and the pilots will have to be consulted. It is wise to do this with an immersing specialists who is able to judge the influence of the requirements on the possibilities and the cost.

For the dredging works on the trench it is a matter of adapting the working methods. It also has to do with the excavating equipment. The experienced dredging companies are very well capable of dealing with these specific requirements.

For the immersing it is often required to stop shipping during a certain period. During transport it depends upon the space available. The same applies for the immersing operations themselves. However it is wise to avoid all sudden movements in the water near to the tunnel elements during the vital activities such as the eventual taking over of the tunnel elements from the tugs to the anchor lines. Or more important the movement of placing the tunnel element against the previous element and closing the joint. However a complete blocking procedure can be limited to a period of 12 hours or even less, depending upon the methodology used and the experience of the immersing contractor.

## **C.2. Suction caused by ships**

The shipping movements can have an influence on the tunnel elements as well. On a number of occasions noted, ships passing over a tunnel element caused suction to the tunnel elements. This depends upon the size of the ships, the size of the tunnel elements, the navigation speed of the ship and most important the space between the ship and the tunnel element.

The maximum forces measured are lifting forces up to 100 tons. When this could be the case one has to take this into account during the various phases of the immersing. It will have an effect on the design criteria.

## **C.3. Navigational depth and clearance requirements**

The available depth in the river used for the towing of the tunnel elements can be decisive for the possibilities of using a casting yard. For steel tunnels, this will seldom be a problem. For concrete tunnel, this can be a problem. Special precautions may have to be taken.

## **D. Soil Investigation**

### **D.1. Data collection - methodology**

A proper soil survey must inform us about the soil conditions to be met. These soil conditions may be of influence to the bearing capacity of the soil. The tunnel in itself has less weight than the soil, that is being replaced by the tunnel. So the criteria of the required soil conditions are not too severe.

The methodology to be used can best be defined by the institution executing the survey. What is the geological history of the area? What works have been performed in the area, that could effect the soil condition? Are there rock formations, etc., etc. ? But in principle the problems are not much different from other civil engineering construction activities.

### **D.2. Trench dredging**

For the shape of the trench and dredging methodology it is advised to do some tests for slope stability, etc. Upon deciding on the trench slopes one has to take into consideration the additional effects of the current velocity in general and the specific conditions during the immersing. One may not risk a sudden slopefall during the immersing

operations. In addition to that, the stability of the foundation and its material against currents or tidal effects should be verified.

A proper survey of the mineral, organic and biological composition of the soil is required to select an optimal dredging technology and to identify the effects on the environment caused by the dredging process. These effects can be negative as well as positive.

### **D.3. Settlement**

One has to keep in mind, that the tunnel placed in the existing bottom replaces a volume of soil, which is much heavier than the tunnel elements with an over weight of around 10 per cent of the weight of the volume.

Depending upon the design methodology regarding the use of flexible joints or rigid constructions some settlement is allowed. Only under very poor soil conditions unacceptable risk may occur. A number of tunnels have been placed on long piles.

Apart from the above mentioned extremely poor conditions, geotechnical conditions do not or hardly cause settlements. Settlements however occur during the ballasting and backfilling of the tunnel elements. This will be caused by the compaction of the foundation layer. This might also be caused by the effects of the dredging and the cleaning of the trench.

### **E. Seismic**

The structure of steel as well as concrete tunnels allow for seismic movements. In relation to the execution methodology the possibility of fluidisation of the foundation underneath the tunnel element thus causing uplift can occur. However, the characteristics of the sand, in case a sand foundation is used, are as such that with a good execution method no liquefaction should be feared. In some cases some clinker is added to the sand underneath the tunnel to strengthen the structure of the foundation.

### **F. Fabrication Sites**

The construction sites of the various techniques are summarized with the description of the construction of the tunnel elements. However, the choice is not only depending upon the construction methodology but it is also influenced by environmental restrictions. These restrictions can be of different backgrounds.

There might be restrictions with respect to the permission to install a casting yard with the dewatering system. This may effect the environment and therefore can be rejected. One might consider the possibility of making a casting yard for all tunnel elements without dewatering, which off course increases the cost considerably but can be competitive especially when this site can be used more than once.

Another solution might be the construction of a smaller yard for one or two elements only. This might decrease the cost of the casting yard, but will increase the time for the construction of the tunnel elements and with that the cost as well. The fabrication process will have to be interrupted.

Another option is the construction of tunnel element(s) in the entrance ramps. This might only be possible for the very short tunnels.

These are only a few of the alternatives. Here again experience will facilitate the selection of the best option. In general it can be said that the steel tunnels have more options for overcoming the environmental limitations. Which might allow for accepting the higher costs of steel tunnels versus concrete tunnels. On the other hand the longer transport routes are not a problem for either of the options subject to sufficient water depth.

#### **16.4. Dredging and Related Ecological and Environmental Impacts**

Dredging will effect the environmental situation at the site. The level of the impact of the process depends upon the local environment, the soil characteristics, the dredging techniques, equipment used and the budget available.

Until recently and still often now, there is a lack of awareness, know how and vision about the ways to deal with dredging. This may lead to the simple establishment of severe restrictions without knowing the effects under the specific conditions. High costs to the principal are the result even without properly solving the problems. Occasionally this even leads to the choice for a bored tunnel in stead of an immersed tunnel, leading to higher risks for the principal.

The approach required is the following [30]:

- (a) Investigate the geotechnical and environmental quality of the soil.
- (b) Investigate the hydraulic conditions of the river, canal or sea.
- (c) Investigate the various options for the dredging technology and the effects of this technology under these specific circumstances.

(d). Specify criteria for the dredging process based upon the requirements for the environmental and ecological effects and the requirements for the construction of the tunnel as such.

(e). Check the proposals of the dredging firms on the criteria specified.

Be aware of the fact, that major dredging firms at this moment invest a lot of money in solutions dealing with ecological and environmental effects of the dredging process. Many techniques are developed to solve the pollution of the bottom of canals and rivers. New technical solutions are and will be available for the future. A proper judgment of the environmental results of these techniques under the specific conditions of the site is important. Part of the effort focused on the result of the dredging is not only the making of the trench and the backfilling but also the control of the environmental effects.

The environmental conditions are very much influenced by seasonal effects. The effects of dredging are often less than these seasonal effects.

There is the possibility to combine the construction of a tunnel with measurements to improve the ecological circumstances. This for instance can be done by cleaning the bottom, placing layers of stones on top of the tunnel, or even installing air injection equipment in the tunnel to improve the quality of the water flowing over the tunnel, once this is finished. With the placing of stones, measurements of the protection of the tunnel can be combined with measurements to improve the environment, allowing for the development of new biological activities.

## **A. Geotechnical, Hydraulic and Environmental Conditions**

Following data are required for a proper judgment of environmental effects related to the advised of proposed dredging methodology [30].

### **Soil in the trench:**

(a) Mineralogical composition. Nature and extent of turbidity differs for different minerals and the absorption of the contaminants of the mineral;

(b) Granular composition. Coarse particles are less susceptible to resuspension is greater in fine fractions owing to greater specific area and loading differences for clay mineral particles at molecular level;

(c) Density, existence of stiff material which interacts with the dredging method;

(d) Consistency of the soil related to strength, cohesion, viscosity and degree of consolidation;

(e) Nature and quantity of the contamination;

(f) The suspension of organic matters depends upon the content of these organic matters.

- (g) Coarse rubbish, chemical nature and gas content.
- (h) Others

**Hydrodynamic condition:**

- (a) Nature and extent of the flow, dispersion and suspension behavior;
- (b) Wave effects;
- (c) Flows resulting from wind;
- (d) Water depth;
- (e) Silt and bottom transport;
- (f) Others.

**Water quality:**

- (a) Density variations influence the sedimentation of material.
- (b) Aerobic or anaerobic state of the layers have an important impact.
- (c) Temperature has a relation to viscosity and density.

In order to predict the effects of the project on the ecological process on the site, it is required to know the details of the ecological and biological process taking place. This is not limited to the site but also to areas where the activities at that site have an impact. Thus in close cooperations with biologists aware of these local conditions an inventory of the ecological process has to be made.

In the following a summary is given of ecological conditions.

**Physical conditions:**

- (a) Temperature;
- (b) Light intensity and penetration;
- (c) Sediment characteristics;
- (d) Shelter- and/or hiding places.

**Chemical conditions:**

- (a) Salinity;
- (b) Oxygen concentration;
- (c) Nutrients;
- (d) Toxic substances;
- (e) Flocculation.

**Biological conditions:**

- (a) Food relations;
- (b) Accompanying species.

## **B. Criteria Related to the Trench**

The trench has to serve a special purpose; the placing of tunnel elements and the foundation underneath. This also has some requirements related to the shape of the trench. The trench being dredged needs to be wide and deep enough with stable slopes.

The bottom of the trench will have to be relatively flat. Too much difference in depth underneath the tunnel element will increase the cost of the foundation and may cause differences in settlement. Apart from this the trench bottom has to be clean prior to the placing of the tunnel element. This requires additional care for the dredging of the deepest part of the trench, cleaning of the trench to avoid sedimentation and consolidation in the trench.

Normally one can say, that the tolerances of the bottom of the trench are plus or minus 15 cm. Since there is a minimum requirement related to the space underneath the tunnel element, it is used to say a tolerance of plus 0 and minus 30 cm is required.

## **C. Evaluation of the Dredging Process, Technical Options**

For a proper evaluation of the dredging process the various activities are identified that have to take place prior to and after the placing of tunnel elements.

For the making of the trench:

- (a) cutting and excavating of the soil;
- (b) vertical transport of the material;
- (c) horizontal transport of the material;
- (d) depositing of the material.

In principle the maintenance of the trench and the backfilling of the trench have the same sequence but the material and the related dredging techniques can or will be different.

The technical options for these activities are numerous. The selected technique has to take into consideration requirements. These requirements are related to the structure of the tunnel, the environmental impact, the soil conditions, the shipping in the area, etc..

For the excavation, known techniques such as a bucket dredger, a cutter or suction dredger or a grabcrane are good opportunities. The selection is depending upon the environmental requirements.

A cutter dredger stirs the material to be dredged which can have a negative effect, but has a close vertical and eventually horizontal transport, when a floating pipe is used.

Stirring will not cause problems with clean coarse material, but might be a disadvantage with slightly cohesive materials.

A bucket dredger does not stir the soil much, but the vertical transport may cause contamination as well as the overflow resulting from the dumping in barges for the horizontal transport. This technique will not be a problem with cohesive and coarse materials but could be a disadvantage with soft and material.

A grabcrane can have the same disadvantage as a bucketdredger, which partly can be solved by using a closed grab. The disadvantage of a grab is the uneven bottom, which influences the foundation and may require additional precautions.

The effects of each of these techniques is very much depending upon the condition and characteristics of the soil and the local hydraulic conditions, specified above. In less or non cohesive fine materials contamination will be great. It might very well be, that the use of a dustpan dredger with an entirely closed transport system for the removal of this layer will avoid negative environmental impacts.

In reality a number of different techniques will have to be used in ecological sensitive areas. This is related to the changing characteristics of the soil. New techniques such as the use of an environmental disc bottom cutterhead or a wormwheel or auger suction dredger are developed and solve the disadvantages of previously mentioned options.

For horizontal transport of the material main options are the use of a closed circuit with pipelines or the use of barges. The shipping near the site has an important influence on the choice in the relation to the available space at the site. With pipelines there will not be contamination around the line but with the overflow from the depot this might be a problem requiring additional precautions. With the use of barges the contamination caused by the overflow and at the dump site have to be taken into consideration.

The cleaning of the trench can be done with a number of the systems developed over the past. Normally a dust pan dredger is being used. This is a section dredger with a special type of opening at the end of the pipe. This opening resembles the head of a Hoover. It is being moved over a bottom of the trench at intervals defined by the quantity of sedimentation and the risk of consolidation.

For the backfilling of the trench several options are available as well. The material used is very important. Clean coarse material will not cause any contamination, whatever technique is used.

Other possibilities to limit contamination are available, such as the use of silt screens, sedimentation basins with the overflows of the deposits, etc..

Apart from this methodology following dredging related aspects influence or may influence the impact to the environment:

- (a) production level and/or the capacity of the dredger;
- (b) technical conditions of the dredger;
- (c) reliability of the methodology and equipment under varying conditions;
- (d) turbidity and spillage from the dredger;
- (e) accuracy and selectivity with the dredging of the various layers;
- (f) use of modifications to limit the turbidity;
- (g) awareness and quality of the staff involved in the preparations and the operation of the dredging process.

#### **D. Selection of the Optimal Solutions**

Above a number of environmental, economic and technical aspects influencing the choice of the techniques are defined. How to optimize the choice in terms of effect and cost? Careful weighing of the various options has to be done. This weighing is influenced by a proper judgment of the ecological effects of the dredging related to the general characteristics of the river.

In a canal or river where there is hardly any or no real biological and ecological activity the conditions will not get worse. Locally these conditions can even be improved due to the removal of polluted soil.

Many rivers have a regime effected by the seasonal cycles. In these seasonal cycles heavy rainfall or the influx of melting water cause more siltation and contamination than the dredging of a trench. The self healing effects in most rivers are enormous and the effects of the dredging work often are eliminated within one or a few season. The moment at which the dredging activities have to be executed, can well be planned depending upon these seasonal effects and the cycles in the biological activities.

When there is a sensitive area in the neighborhood, such as oyster beds, lobster nurseries, etc. it is often very well possible to benefit from current to direct the siltation caused by the dredging in a direction away from the sensitive area. An accurate description of the dredging works to be executed, a proper defining of the dredging limitations in place and time, with an adequate control during execution, will be able to limit environmental effects of the dredging operations, both in the direct project area as in the surrounding areas.

After the construction of the tunnel when the hydraulic circumstances in terms of cross section of the river are changed permanently, these effects have to be taken into consideration. This might lead to compensation elsewhere.

## 16.5. Construction of the Tunnel Elements

### A. Construction of the Tunnel Elements

#### A.1. Steel option

The steel shell tunnels are composed of a structural steel shell lining. This lining forms a composite structure with the concrete also serving as ballast to the structure. This methodology allows for use of a number of different construction methods and sequences for the steel option [30].

The steel shell or part thereof is being constructed. Possibly some of the keel concrete is added to the structure to increase the stability and rigidity of the structure. Subsequently the steel structure can be put afloat. This allows for the use of ship yard, ship ways, ship lifts, dry docks and/or a temporary construction basin. The tubes can be launched sideways as well as end launched. Off course this guided launching will have to be done properly controlled making use of guided structures, properly leveled, winches and jacks, chains, etc..

Once the tunnel element is put afloat it is towed to an outfitting jetty for the finishing of the steel structure if required and the placing of the concrete or the remaining part thereof. In addition to that specific requirements regarding the marine operation such as temporary bulk heads, joint structures, access shafts, etc. are being installed.

Additional ballast either concrete and/or gravel is being placed on the tubes prior to the immersing.

No need to emphasize, that the design of the tubes will have to be adapted to the fabrication methodology and sequence. However, this allows for a certain flexibility to optimize the construction in relation to the fabrication capabilities.

As mentioned above, the basis of design is shipyard fabrication of a cylindrical steel shell, but the finished tunnel usually comprises a reinforced concrete structural lining and a road deck, within a cylinder about 10 meters in diameter of 8 mm thick steel, surrounded by concrete contained within a thin octagonal steel casing.

The outer concrete, for which the steel octagon acts as formwork, provides external protection against damage and corrosion, and necessary ballast, contributing also to structural rigidity as shown in *Figure 16.3* [31].

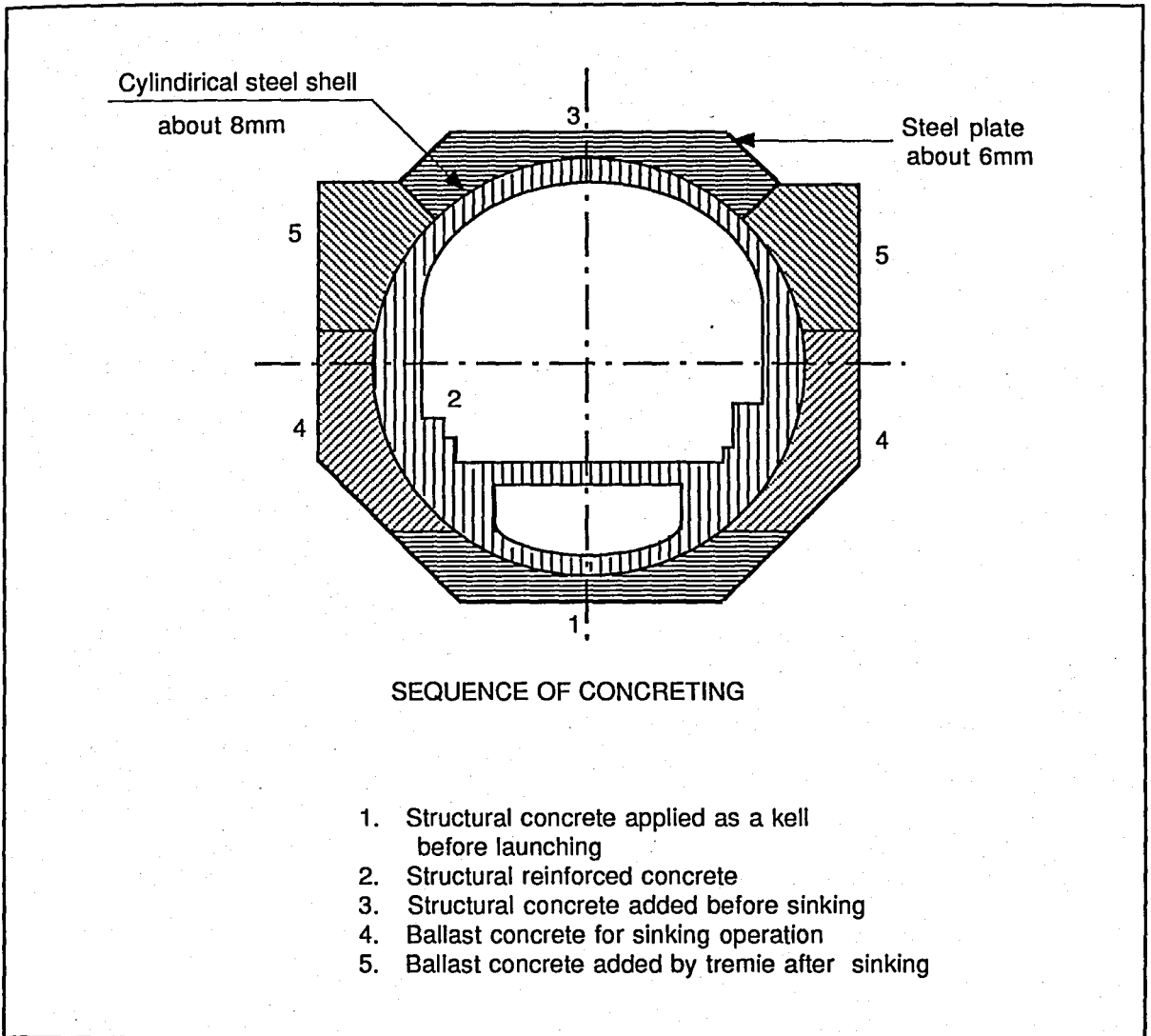

FIGURE 16.3. TYPICAL CROSS SECTION OF A STEEL TUNNEL

## A.2. Concrete option

Smaller concrete cross section can be launched or be built on a ship lift, ship ways, or other. With bigger cross sections, this will be difficult. Normally existing docks and excavated casting yards are used.

## B. Finishing Jetty

The criteria regarding these docks are dictated by the draught of the tunnel elements. With concrete tunnel elements a depth of the casting dock equal to the height of the tunnel elements below low water is preferred. Sections of the concrete in the roof and eventually the bottom can be casted at a later stage at the finishing jetty near the immersing place. In other cases it is also possible to increase temporarily the water level on the canal.

The increasing restrictions regarding the dewatering of the casting yard may require additional provisions to avoid the disadvantages of the dewatering. This may lead to increasing costs of the casting yard. This is more and more solved by making use of existing casting yards, where the problems do not occur and/or are solved, at locations far from the immersing site. The transport of these huge tunnel elements now are only limited by the required manoeuvring space.

Once the tunnel elements are fabricated and ballasted, including many of the provisions for the immersing, the dock is flooded and the tunnel elements can be put afloat. This is done by removing ballast water. The tunnel elements are connected with anchor points and put afloat in a well controlled way, to avoid drifting of the tunnel elements. Subsequently the tunnel elements are towed to the finishing jetty.

## C. Transport of the Tunnel Elements

Following matters are of importance,

- (a) the conditions to be met;
- (b) the behavior of the tunnel elements under the specific conditions at the site;
- (c) the space available in the navigation channel;
- (d) the type and capacity of the tugs;
- (e) the location system and the way these results being presented to the operation leader;
- (f) the organization during the transport with the personal and the equipment involved.

Assuming, that the conditions and the effects that these conditions will have on the tunnel element are known, the methodology during transportation has to be defined. The capacity and the number of tugs depend upon the resistance of the tunnel element in the

river, canal or at or sea as well as the space available for maneuvering. Another decisive factor may be the fleet available on that location.

When the available space is narrow, an accurate and fast working navigation system is required to inform about the position of the tunnel element in the available space. The faster the system is, the more time is available to give instructions to the tug captains and to correct the position of the tunnel element. This is of importance because the huge mass of the tunnel elements cause a considerable delay in the corrective reaction of the tunnel elements.

In relation to that the attention has to be paid to the type, the number, the capacity and the lay out of the tugs.

When the system passes a lock or a bridge with limited space it might be advisable to make use of winches. when the transport from the finishing jetty to the immersing place is short only winches can be used. Taking over the tunnel element from tugs to the winches is an operation, that has to be properly prepared in relation to the conditions being met.

Transport over sea is entirely different from the transport in a river or canal. Here, the structure of the tunnel is capable of facing the forces resulting from the swell as mentioned before.

So far the transport of a tunnel element afloat has been dealt with. It also happens during the part of the transport and also depending upon the size of the elements, steel or concrete, and/or the equipment used, that the tunnel element is connected to a piece of equipment also serving for the immersing. In that case the tunnel element most often is already ballasted for the immersing operation.

Since transport of huge and complicated structures is not an exception anymore, a computer model called Ships Response System has been developed to forecast forces on and in the structure.

To give some idea about a tow operation under average conditions in a river with tunnel elements of 30.000 to 40.000 tons, a total tow capacity of 10 to 20.000 HP with 4 tugs, eventually with push possibilities, will be required. It is assumed, that 1000 WP results in 10 tons tow capacity. Depending upon the manoeuvrability two or three times the theoretical capacity is required to control the position of the tunnel element.

The scheduling of a tow operation is done in such a way that maximum use is made from local tidal conditions, changes in water height, current velocity and direction.

## D. Immersing

Since huge elements are used, under relatively difficult conditions, where much of the work is being done without a direct view on the activities it is of major importance to make things as simple as possible and to benefit as much as possible from the natural capabilities of water [30].

This requires the information regarding the various environmental conditions as specified earlier. This also requires the skills, experience and know how to be able to interpretate the information data achieved to the operations as planned. It is advised to work with an over capacity in the equipment, sufficient safety margins, etc..

An integrated part of the preparations for the immersing forms a proper risk analysis of the operations with sufficient backup facilities to the equipment. It is wise to make the operations reversible and to foresee various steps.

However, the immersing under normal protected conditions does not have many secrets to the experienced tunnel builder.

### D.1. Vertical control of steel tunnel elements

Prior to the immersing, elements are attached to the immersing pontoons. These pontoons normally consist of a set of two or four pontoons with bridges in between. The tunnel element is suspended to these bridges.

In order to increase the weight of these steel tunnel elements, they can be ballasted by additional concrete and/or gravel. This is placed on top of the tunnel element when it is suspended from the immersing equipment.

The immersing happens when the tunnel elements are lowered with winches on the pontoons. Once the tunnel element is close to the bottom it is lowered against the previous element before placing on the gravel bed foundation. Temporary jointing is made by rubber gaskets and permanent joints are made after the removal of temporary bulk heads. Perspective view of joint connection is shown in *Figure 16.4* [31].

### D.2. Vertical control of concrete tunnel elements

With concrete tunnel elements this might be different. Once these tunnel elements are built in the casting yard, they are being ballasted with water in order to remain at the bottom of the dock, when this is being filled with water. The ballast water is pumped out of the tunnel elements to make these float.

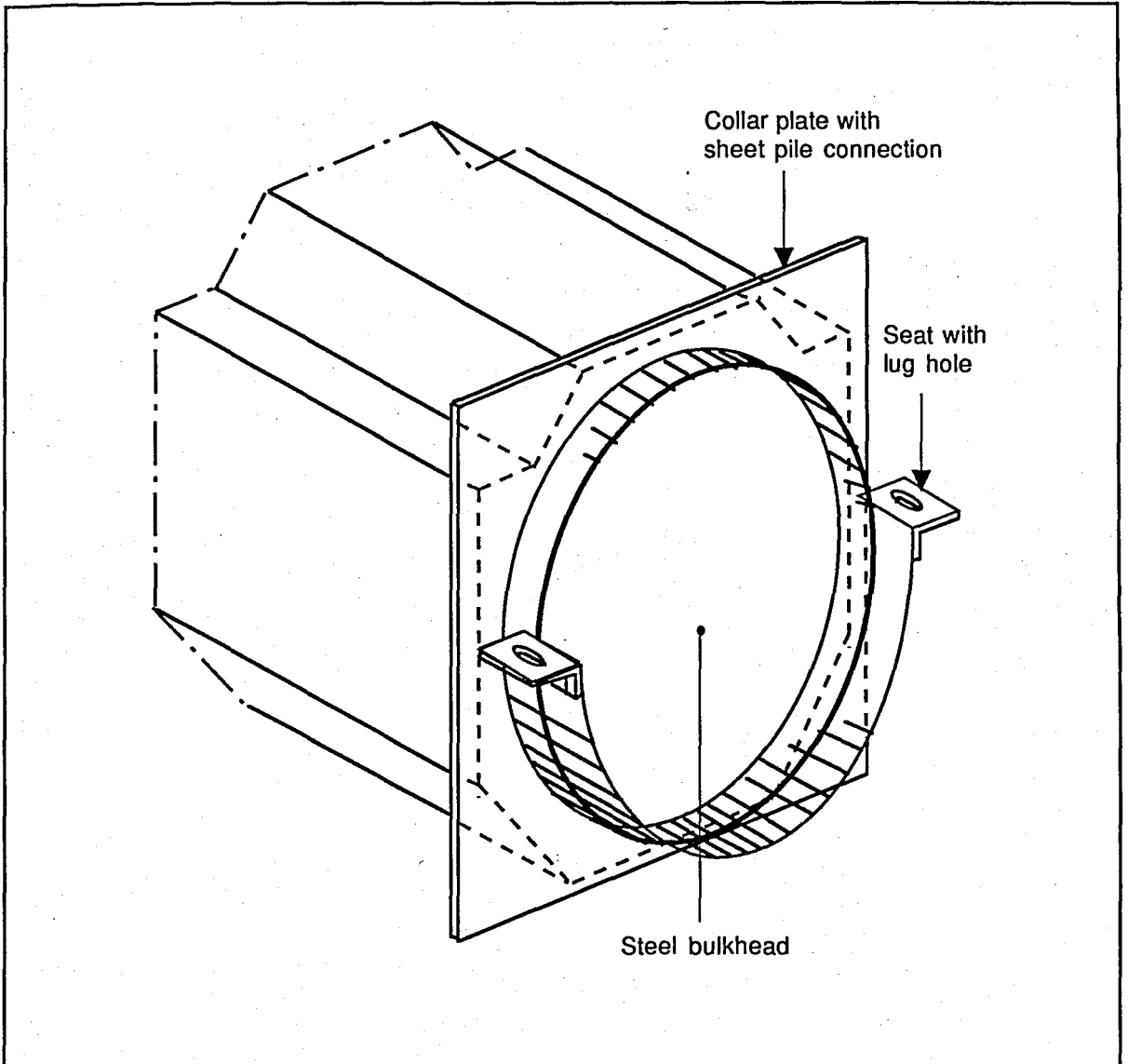

FIGURE 16.4. PERSPECTIVE VIEW OF JOINT CONNECTION

The equipment most often used consists of pontoons being adapted for the job. These pontoons can be placed on top of the tunnel elements prior to putting the tunnel element afloat, or at a later stage by floating cranes. The pontoons are equipped with winches to anchor the tunnel elements and the pontoons or the pontoons only [30].

Once the tunnel element is moored to the anchors, the ballast tanks are partly refilled with water until the tunnel element has sufficient negative buoyancy.

Another option is to make use of additional floating bodies or stability towers to the tunnel elements. These stability towers need to have sufficient floating capacity and a cross section at the water level of sufficient size and are placed on top of the tunnel elements. With these stability towers and the ballast water the tunnel elements are perfectly under control.

Once the tunnel elements are close to the final position, they are placed on a structure on the previous element and on temporary struts at the free or secondary end of the tunnel elements. The final positioning is done with jacks in these struts allowing for possibilities to correct settlement, misplacement, etc..

### **D.3. Horizontal control**

The horizontal control of the tunnel element is normally created by winches, anchorlines and anchors in the water or ashore. These winches can be placed on the pontoons. But when the current has some strength it is of importance to have a direct control over the movements of the element, which can be achieved by placing winches in towers on top of the tunnel elements. Another alternative to this is placing winches ashore.

One can distinguish following steps. The tunnel elements are being towed or winched to the immersing site. Still afloat, the tugs are being replaced by winches connected to anchors in the river or ashore. During the lowering of the tunnel element the horizontal position of the tunnel element is being checked continuously. Subsequently the tunnel element is placed with the primary end on a guiding structure on the secondary end of the previous tunnel element [30].

The final axis of the tunnel is very much dictated by the precise measurement of the end rings of the tunnel elements containing the gina profile. The tremendous water pressure pushes the tunnel element firmly against the previous element at the same time dictating the direction of the axis.

*Figure 16.5 shows the submerged tunnel construction [31].*

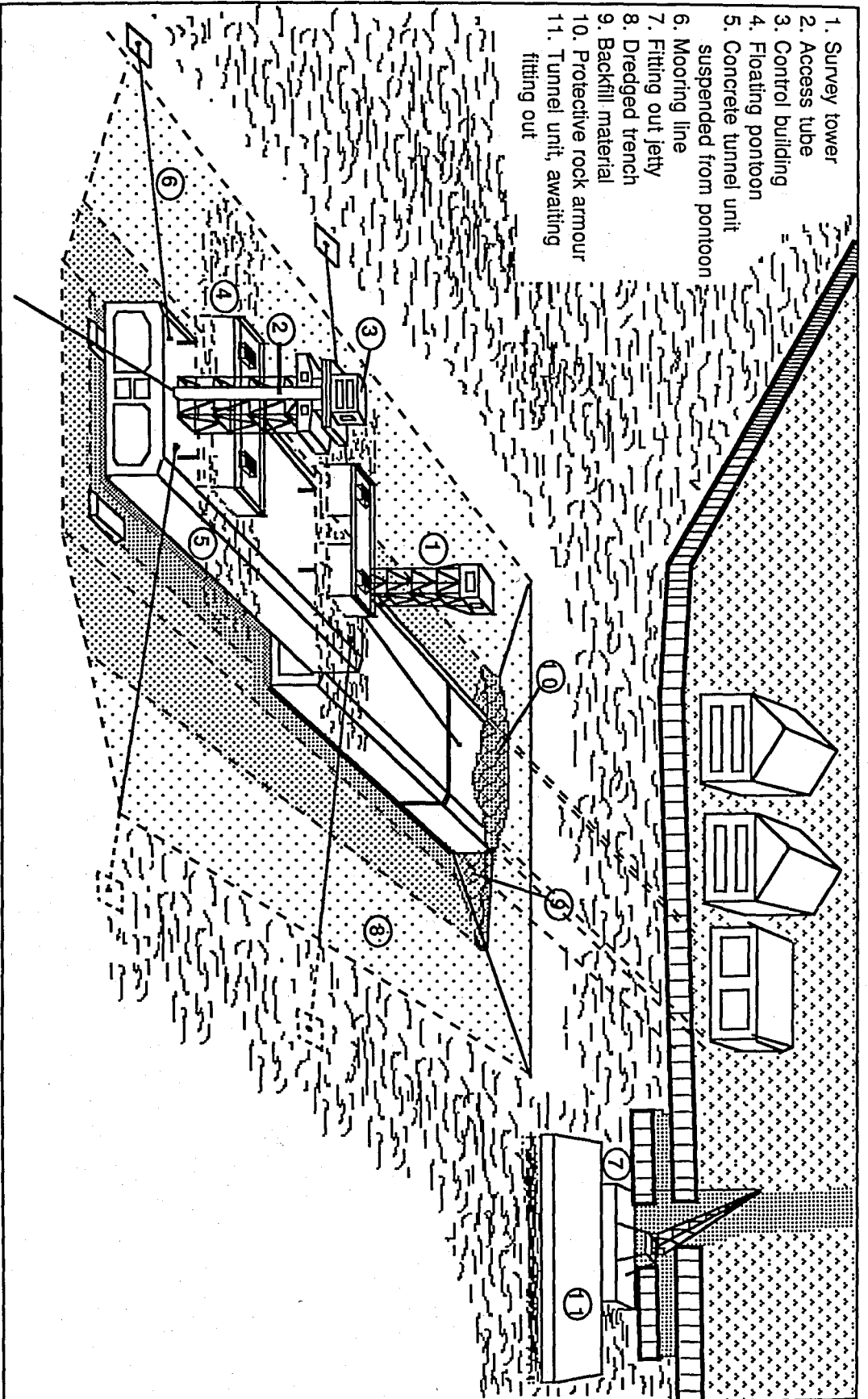

FIGURE 16.5. SUBMERGED TUNNEL CONSTRUCTION

#### **D.4. Other equipment related options**

The working methods briefly described above are very common. This is due to available equipment, experience over the past, etc.. Another option is the use of spud or self elevating pontoons.

Using this type of equipment has the advantage, that the immersing operations on site can be limited in time and that the intervals between the immersing of each tunnel element can be limited as well. So far sequences of one tunnel element every 24 hours have been achieved.

The choice between these and other options depend upon a combination of matters such as the number of tunnel elements, the site conditions, the time schedule available, specific requirements from the client, equipment available, etc.. It is a matter of economy, technique and most of all experience, skills and know how to select the best option.

#### **E. Positioning**

The system to precisely define the location of the tunnel element in the river and/or the trench has undergone important changes. These changes were the result of new technology in the possibilities for survey above as well as under water. Thanks to these development the period required for the immersing of a tunnel element is considerably shorter and the risk of surpassing the time available has decreased.

With the survey system attention has to be paid to the accuracy and the vulnerability of the system for outside as well as internal conditions.

#### **F. Tunnel Foundation**

There are three different systems available. In Europe the sand jetted and sand flowed systems are commonly used. In America it is the Screeded gravel bed which is common practice [30], [32].

In the case of a sand foundation the tunnel element is temporary founded directly after the immersing until it can be lowered on the final foundation.

The temporary foundation at the primary end, which is the end connected to the previous tunnel element, is the guided support of the tunnel element on a structure connected to the previous element.

The temporary foundation at the secondary (or free) end consists of concrete or steel slabs being placed in the trench, prior to the immersing of the tunnel element. Attached to

the tunnel element and located above these slabs is a steel structure consisting of bars and jacks connected to the tunnel element. With this system corrections of the position of the element can be done during the following phases.

### **F.1. Screeded gravel bed**

This foundation type is generally used in North America, with steel shell tunnels. Following the dredging of the trench a layer of coarse sand or gravel is placed on the bottom of the trench.

The gradation of the material must be related to the hydraulic conditions. The stronger the current, the higher the gradation. The layer will be around 0.70 meters thick.

Much attention must be paid to the accurate leveling of the gravel bed. The accuracy is plus or minus 3 cm, depending upon the local conditions, the gradation of the materials and the equipment used. Leveling is done with a screed suspended from winches on a carriage rolling on tracks supported on two pontoons.

The rig is anchored above the surface to be leveled. Tide level changes are compensated by adjustments of the screed suspension. In order to exclude as much as possible the influences from the surface special equipment can be used based upon the principle of semisubmersibles and the screed can be directly connected to "anchor blocks".

### **F.2. Sandjetting foundation**

To fill the space between the dredged trench floor and the underside of the tunnel while this is temporarily supported, a space typically 0.6 meters to 1.2 meters high and ranging from less than 10 meters to more than 40 meters in width, the late chief engineer at Christiani & Nielsen A/S, and later professor at the technical University of Denmark, A.E. Bretting, in 1935/36 invented the sandjetting method.

As mentioned above the first system creating a sand foundation is the C&N method making use of a gantry of steel running over the tunnel element. Connected to this gantry there are three pipes next to each other. This system of pipes is going to the space underneath the tunnel between the bottom of the tunnel and the bottom of the trench. The biggest pipe is in the middle.

Through this pipe a sand/water mixture of well controlled composition is being pumped underneath the tunnel element. The other two pipes at both sides suck the water back. Thus a flow is created which settle the sand underneath the tunnel element according

to a well defined and controlled pattern. Principle of the C&N sandjet system is shown in *Figure 16.6*.

The gantry on the tunnel element and the possibility to turn the pipes around a vertical axis allows for covering the whole space underneath the tunnel element. The space required for the moving of the pipes underneath the tunnel elements will have to be around 1 meter.

The sand must be clean. The grain size of the sand has an average of about 0.5 mm. The process must be well controlled regarding the concentration and the exist velocity of the sand/water mixture, which is directly connected to the diameter of the pancake.

### **F.3. Sand-flow system**

In order to avoid the use of a gantry, which might be an obstruction to the shipping and to be able to place foundations under deeper tunnels the sand-flow method has been developed. The principal of the sand-flow system is shown in *Figure 16.7*. Like the sandjetted system a sand water mixture is being pumped through pipes to the space underneath the tunnel element. In stead of a movable system a number of openings are made in the bottom of the tunnel element.

These openings are connected to pipes either inside the tunnel elements or outside. The choice may depend upon shipping requirements, local conditions and preferences of the contractor. When the pipes run from ashore through the tunnel to the opening to be filled, there is no hindrance at all to the shipping.

Through these openings the sand water mixture is being pumped. The sand fills the space underneath the tunnel element until the "crater" touches the bottom of the element. Following that moment an expanding pancake is formed underneath the tunnel, until the internal water pressure in the pancake is surpassing a preestablished maximum. Subsequently the next opening will be opened and the previous closed

The size and the pattern of the openings, the characteristics of the sand, the depth of the tunnel, the overweight of the elements and other aspects are related to each other. This method is very fast and can fill the entire space underneath a tunnel element within 24 hours, thus avoiding the risk of siltation after the placing of the elements.

### **F.4. Cleaning of the trench**

The cleaning of an open trench is mentioned in the paragraph dealing with dredging. On a number of projects siltation of the trench was a problem.

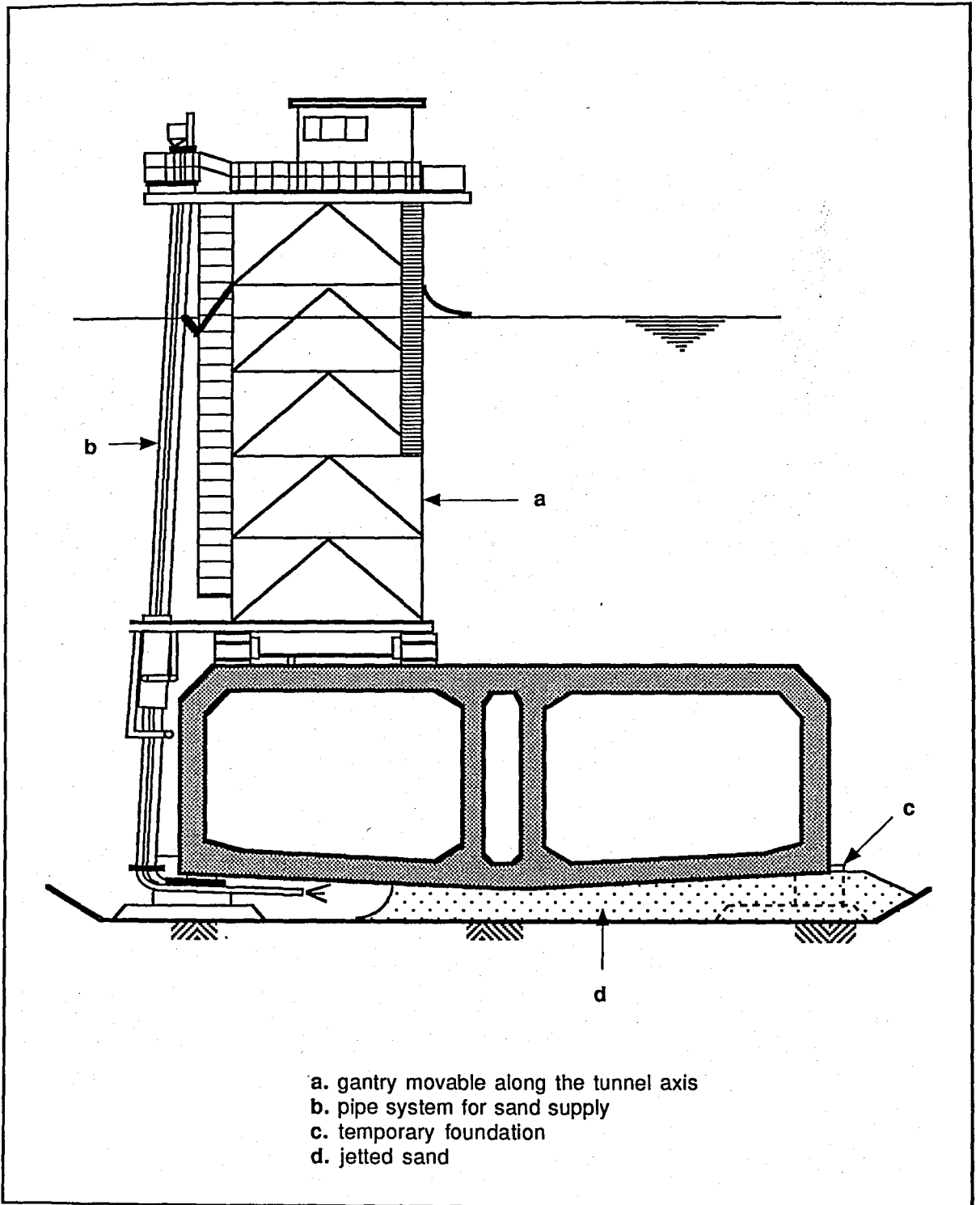

FIGURE 16.6. PRINCIPAL OF THE C&N SANDJET SYSTEM

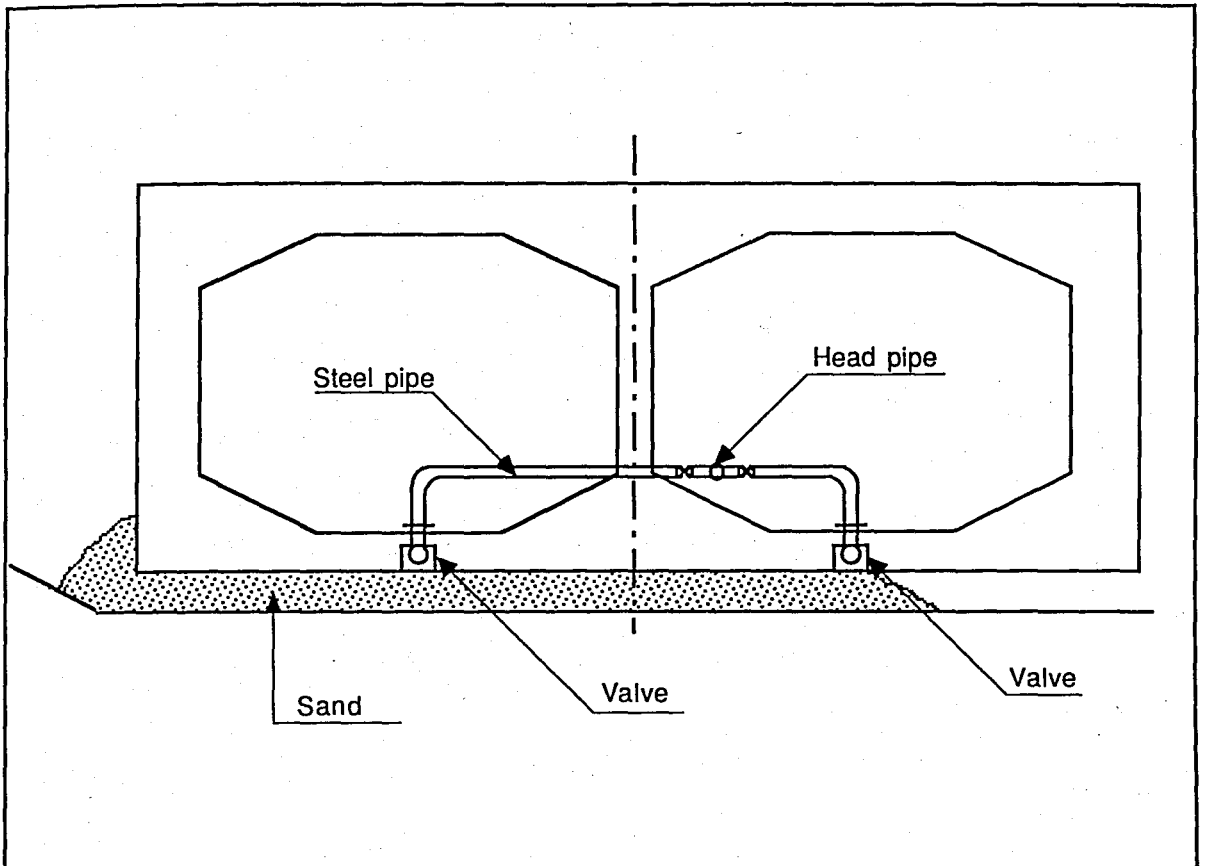

FIGURE 16.7. PRINCIPLE OF THE SAND-FLOW SYSTEM

In case there is a risk of sedimentation by bottom transport and/or siltation in the river in the space underneath the tunnel elements, serious consideration has to be given to solving of this problem. In general terms it can be stated that removal of this siltation from underneath a tunnel element is not possible at limited costs. It therefore is essential to avoid this sedimentation.

With a foundation of a gravel bed the risk is nil. There is no open space underneath the tunnel element. With a sand flow system with transport through pipelines and openings in the tunnel bottom these problems can easily be avoided as well.

The system allows for a very fast filling of the space underneath tunnel elements with a bottom surface of 3500 sq.m. is done within a period of 24 hours. With the C & N sandjetting system, the capacity of the system to remove the silt is limited as is the capacity to fill the entire space underneath a tunnel element.

## **16.6. General Matters**

### **A. Quality Control**

As emphasized before, the quality control for an immersed tube tunnel has to pay specific attention to a number of matters. Apart from the standard procedures for concrete and other related activities special attention has to be paid to water tightness of the concrete for concrete- as well as the steel shell for steel tunnels. Steel will have to be X-rayed, concrete will have to be checked on cracks.

There is a possibility to check the water tightness once the graving dock are being flooded. A repair of eventual leaks is then expensive and can better be avoided, but is always technically feasible.

The weight of the tunnel elements in relation to size and buoyancy of the tunnel elements will have to be closely monitored.

The joints between the various segments of the tunnel elements require special care. The methods of check and control depend upon the system of which there exists a quite variety.

Much attention will have to be paid to the quality control of the marine related activities. It is of major importance to properly test the system and equipment used for monitoring conditions and for positioning. For instance it is very important to properly measure the depth of a trench, the siltation, etc.. This mostly depends upon the circumstances and the equipment capable of dealing with specific circumstances.

## **B. Risks**

The risks related to a multi disciplinary project like an immersed tube tunnel can be distinguished in risks, related to technical matters, related to time schedule and in relation to the two already mentioned to the cost. The risks of these type of projects are not basically different than the other civil engineering projects This off course is assuming, that the most important requirements regarding the input of experience and know how are fulfilled.

When we look at the history of immersed tube tunnels we do not see any major accident or event having an impact on the project itself or third parties. The reason might be, that, due to the great impact an event should have, much is invested in a proper preparation of the activities. This in terms of risk analysis since long common by these type of project, extensive survey being performed in advance, back up facilities included in the systems, etc.

Compared to other big schemes the immersed tunnel is to be seen as a relative safe and sound system. Big dramatic occasions are not known.

However, on a number of projects, considerable cost- and time overruns have been seen. These were often justified as unforeseen events. This not necessarily means, that these events could not have been foreseen. Although a project under water is not easy to perform, unforeseen events can be neglected by properly investigating the external conditions, taking these into account upon designing and building the tunnel and properly controlling all relevant aspects of the project.

### **B.1. Time schedule**

The construction of the tunnel can be split in a number of separate projects. Each approach ramp, the construction of the tunnel elements, the marine activities and the finishing of the works, civil as well as electromechanical are different projects often on different locations. This split in the projects will lead to a number of activities running parallel to each other.

Part of the activities are repetitive. The construction of the tunnel elements, part of the approach ramps, the immersing, etc. are a repetition of the same activities. A sudden set back can often been neutralized by increasing the number of forms, additional equipment or extra works at night, during the weekends and with holidays.

However, compared to bored tunnels the risk of time over runs are considerably less. The time required for the construction of a bored tunnel is very much depending upon the production outcome of the tunnel boring machine. It is difficult or impossible to improve this during the coarse of the project. With an immersed tunnel, there is much more flexibility.

## **B.2. Cost**

As is stated above some projects have considerable cost overruns. These cost overruns may be the result of an extension of the work due to additional requirements or to cover the extra work resulting from unforeseen environmental circumstances.

When in all levels of the organization with the design as well as with the construction skilled personal is involved the cost overruns should not exceed five percent of the value of the project. Moreover, experienced people can properly estimate the sum required to cover eventual cost overruns.

## **C. Project Management**

As will be clear from the description of the various aspects related to the construction of immersed tube tunnels these type of projects are multi disciplinary. Furthermore the construction normally takes place at locations, where other activities may interfere with the construction.

With the construction of these type of tunnels, various sites are created, each shore will have an approach ramp, in between the marine operations take place. The elements are constructed at another location. everything has to be fit perfectly together.

Mentioned aspects above emphasize the necessity of perfect cooperation between persons and parties involved. A problem at one place may result in a disaster at another place, when the cooperation fails.

It thereof is of vital importance to create a perfect cooperation between all parties involved and guided by a skilled and experienced group of people. Some guidelines are given hereafter [30].

- (a) All relevant parties must be defined in an early stage of the project. Their specific requirements, skills and contributions must be known to all parties involved and all aspects must be covered.
- (b) The team of responsible key persons much be created in an early stage of the project. This team must have skilled specialists and must be guided by an experienced tunnel specialists.
- (c) Design and construction are closely related to each other. It therefor is advised to have an early input in the design from the construction company. The construction must not be worked out in too much detail prior to the tender of the project.

(d) A project of this type is perfect for design and construct projects. However, in order to limit the cost for the design as much as possible and to create the maximum competition the client must put at the contractors disposal the maximum of information available. The collection of this information must be done by specialists knowing the local circumstances and by specialists of immersed tube tunnels.

(e) The team must operate as an integrated team independently from the contractual arrangements between parties.

(f) The communication with third parties must be well organized. Especially during the marine operations good communications are required to avoid problems with catastrophic results.

(g) Each party must be informed of all available information and must have access to this information.

#### **D. Project Finance**

Recently a number of these tunnel projects have been built making use of privately financed money. Within the scope of this work, the details of private financing are not dealt with. Some of the effects of private financing on these projects in addition to remarks made above are mentioned. It might be of importance for the for the application of these techniques for the future.

The time schedule with privately financed projects is being influenced, so that the tunnel must be built in the shortest period. The optimal period should be the result of a cost benefit comparison between investment in fast construction techniques, equipment, etc. A tight time schedule should not be at the cost of the quality of the work. It requires experience and know how to properly define the optimum. As a result from the tight time schedule the design might have to be optimised.

The difficulty with private financing often is, that the politicians acting on the behalf of the society are not willing or capable to define the requirements regarding the total package of design, construct, finance and operate projects.

This also means, that the authorities advising the politicians in the interest of the society, need to have the capabilities to properly define the technical and additional requirements of the society.

It is vital, that prior to real start of the work all related parties are identified. This must cover the whole scope of the project. These parties must be capable to identify and judge all risks and to cover these risks, either technical and/or financial.

## 16.7. World List of Immersed Tubes

The schedule, up to the end of 1986, is shown in *Table 16.1 to 16.4*. The main increase in immersed-tube tunnels occurred in the two decades following 1960 when the numbers increased from 16 to 61, with eight being completed in 1969 alone. Prior to 1940 there were only five such tunnels, all in the USA except for a small pedestrian tunnel in Berlin [33].

### A. Rupel Tunnel

This is a dual three-lane road tunnel, 595 meters between portals (item 62), which carries the A12 Brussels-Antwerp motorway. It passes beneath the Willebroek Canal, the Rupel River and an island separating these and replaces a fixed and a lifting bridge. There are three immersed-tube units, each of the rectangular reinforced concrete box type, one of length 138 meters under the canal and two of length 99 meters under the river, the former having a displacement of 46000 tones.

Water proofing is by means of a steel plate beneath the unit and a bituminous membrane on the sides and top. Across the width of the island, construction was in-situ, using permanent diaphragm walling, so avoiding undue disruption to the working of a shipyard located there. The units were cast in the open approaches to the tunnel and then warped into the position, prior to sinking in the normal way. The foundation are of the external sand-jetted type.

Considerable problems were encountered in the construction of the in-situ section across the island due to the unexpected presence of large boulders, which impeded the proper driving of some of the deep steel sheet piling across the canal end of this section. This led to flooding and there was a delay of almost two years before the problems were satisfactorily overcome.

### B. Spijkenisse and Coolhaven Tunnels

The next two tunnels, the Spijkenisse and Coolhaven in Rotterdam, are small, two-track rail tunnels which form part of extensions to the Rotterdam Metro, the first phase of which was built in the 1960s. The Spijkenisse Tunnel is 1142 meters between portals and passes under the Oude Maas. The units are of similar cross-section to those of the original system (item 63 and 64), with two compartments and overall dimensions 10.36x6.55 meters. Those for the Coolhaven, which is a short tunnel under part of the harbor. are of plain rectangular shape, with a single compartment and overall dimensions 9.64x6.35 meters.

TABLE 16.1. WORLD LIST OF IMMERSIED TUBES

















| No | YEAR | NAME                | PURPOSE               | LOCATION                             | TUBE LENGTH | CROSS-SECTION  | LANES/TRACKS | FORM |
|----|------|---------------------|-----------------------|--------------------------------------|-------------|--|--------------|------|
| 1  | 1910 | DETROIT RIVER       | RAILWAY               | MICHIGAN, U.S.A./<br>ONTARIO, CANADA | 800m        |    | 2x2          | S    |
| 2  | 1914 | HARLEM RIVER        | RAILWAY               | NEWYORK                              | 329m        |    | 4x1          | S    |
| 3  | 1927 | FREIDRICHSHAFEN     | PEDESTRIAN<br>FOOTWAY | BERLIN                               | 120m        |    | —            | R    |
| 4  | 1928 | POSEY               | ROAD                  | OAKLAND,<br>CALIFORNIA<br>U.S.A      | 742m        |    | 2            | R    |
| 5  | 1930 | DETROIT-WINDSOR     | ROAD                  | MICHIGAN, U.S.A./<br>ONTARIO, CANADA | 670m        |    | 2            | S    |
| 6  | 1940 | BANKHEAD            | ROAD                  | MOBILE, ALABAMA<br>U.S.A             | 610m        |    | 2            | S    |
| 7  | 1941 | MAAS                | ROAD                  | ROTTERDAM<br>NETHERLANDS             | 587m        |    | 2x2          | R    |
| 8  | 1942 | STATE STREET        | RAILWAY               | CHICAGO, ILLINOIS<br>U.S.A           | 61m         |    | 2x1          | S    |
| 9  | 1944 | AJI RIVER           | ROAD                  | OSAKA<br>JAPAN                       | 49m         |   | 2x1          | S    |
| 10 | 1950 | WASHBURN            | ROAD                  | PASADENA, TEXAS<br>U.S.A             | 457m        |  | 2            | S    |
| 11 | 1952 | ELIZABETH RIVER (1) | ROAD                  | PORTSMOUTH,<br>VIRGINIA<br>U.S.A     | 638m        |  | 2            | S    |
| 12 | 1953 | BAYTOWN             | ROAD                  | BAYTOWN, TEXAS<br>U.S.A              | 780m        |  | 2            | S    |
| 13 | 1957 | BALTIMORE           | ROAD                  | BALTIMORE,<br>MARYLAND<br>U.S.A      | 1920m       |  | 2x2          | S    |
| 14 | 1957 | HAMPTON ROADS (1)   | ROAD                  | VIRGINIA, U.S.A                      | 2091m       |  | 2            | S    |
| 15 | 1958 | HAVANA              | ROAD                  | CUBA                                 | 520m        |  | 2x2          | R    |
| 16 | 1959 | DEAS ISLAND         | ROAD                  | VANCOUVER<br>CANADA                  | 629m        |  | 2x2          | R    |
| 17 | 1961 | RENSBURG            | ROAD                  | KEIL<br>GERMANY                      | 140m        |  | 2x2          | R    |

TABLE 16.2. WORLD LIST OF IMMERSED TUBES















| No | YEAR | NAME   | PURPOSE          | LOCATION                   | TUBE LENGTH            | CROSS-SECTION  | LANES/TRACKS         | FORM |
|----|------|--|------------------|----------------------------|------------------------|--|----------------------|------|
| 18 | 1962 | WEBSTER STREET   | ROAD             | OAKLAND, CALIFORNIA U.S.A  | 732m                   |    | 2                    | R    |
| 19 | 1962 | ELIZABETH RIVER (2)  | ROAD             | PORTSMOUTH, VIRGINIA U.S.A | 1066m                  |    | 2                    | S    |
| 20 | 1964 | CHESAPEAKE BAY<br>(a) THIMBLE SHOAL TUNNEL<br>(b) BALTIMORE CHANNEL TUNNEL | ROAD             | VIRGINIA, U.S.A            | (a) 1750m<br>(b) 1661m |    | 2                    | R    |
| 21 | 1964 | LILJEHOLMSVIKEN  | RAILWAY          | STOCKHOLM                  | 123m                   |    | 2                    | R    |
| 22 | 1964 | HANEDA   | MONORAIL         | TOKYO                      | 56m                    |    | 2x2                  | S    |
| 23 | 1964 | HANEDA   | ROAD             | TOKYO                      | 56m                    |    | 2                    | S    |
| 24 | 1966 | COEN   | ROAD             | AMSTERDAM                  | 540m                   |    | 2x2                  | R    |
| 25 | 1967 | BENELUX  | ROAD             | ROTTERDAM NETHERLANDS      | 745m                   |    | 2x2                  | R    |
| 26 | 1967 | LAFONTAINE   | ROAD             | MONTREAL, CANADA           | 768m                   |  | 2x3                  | R    |
| 27 | 1967 | VIEX-PORT  | ROAD             | MARSEILLES FRANCE          | 273m                   |  | 2x2                  | R    |
| 28 | 1967 | TINGSTAD   | ROAD             | GOTENBURG SWEDEN           | 452m                   |  | 2x3                  | R    |
| 29 | 1968 | ROTTERDAM METRO  | RAILWAY          | ROTTERDAM NETHERLANDS      | 1040m                  |  | 2x1                  | R    |
| 30 | 1969 | U  | ROAD             | AMSTERDAM                  | 790m                   |  | 2x2                  | R    |
| 31 | 1969 | SCHELDT E3<br>(J.F.K. TUNNEL)  | ROAD/<br>RAILWAY | ANTWERP, BELGIUM           | 510m                   |  | 2x3<br>ROAD<br>2 TR. | R    |
| 32 | 1969 | HEINENFORD   | ROAD             | BARENDRECHT NETHERLANDS    | 614m                   |  | 2x3                  | R    |
| 33 | 1969 | LIMFJORD   | ROAD             | ARLBORG DENMARK            | 510m                   |  | 2x3                  | R    |
| 34 | 1969 | PARANA (HERNANDIAS)  | ROAD             | SANTAFE ARGENTINA          | 2356m                  |  | 2                    | R    |

TABLE 16.3. WORLD LIST OF IMMERSED TUBES

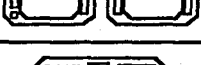
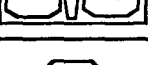

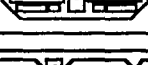











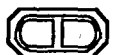













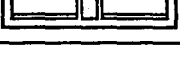

| No | YEAR | NAME                   | PURPOSE          | LOCATION                      | TUBE LENGTH | CROSS-SECTION  | LANES/TRACKS | FORM |
|----|------|------------------------|------------------|-------------------------------|-------------|--|--------------|------|
| 35 | 1969 | DOJIMA RIVER           | RAILWAY          | OSAKA JAPAN                   | 72m         |    | 2 x 1        | R    |
| 36 | 1969 | DOHTONBORI RIVER       | RAILWAY          | OSAKA JAPAN                   | 25m         |    | 2 x 1        | S    |
| 37 | 1969 | TAMA RIVER             | RAILWAY          | TOKYO                         | 480m        |    | 2 x 1        | S    |
| 38 | 1970 | KEIHIN CHANNEL         | RAILWAY          | TOKYO                         | 328m        |    | 2 x 1        | S    |
| 39 | 1970 | BAY AREA RAPID TRANSIT | RAILWAY          | SANFRANCISCO CALIFORNIA U.S.A | 5825m       |    | 2 x 1        | S    |
| 40 | 1971 | CHARLES RIVER          | RAILWAY          | BOSTON, MASS.                 | 146m        |    | 2 x 1        | S    |
| 41 | 1972 | CROSS-HARBOUR TUNNEL   | ROAD             | HONG KONG                     | 1602m       |    | 2 x 2        | S    |
| 42 | 1973 | EAST 63rd ST. TUNNEL   | RAILWAY (PART *) | NEWYORK                       | 2x229m      |    | 4 x 1        | S    |
| 43 | 1973 | I 110                  | ROAD             | MOBILE, ALABAMA U.S.A         | 747m        |   | 2 x 2        | S    |
| 44 | 1973 | KINUURA HARBOUR        | ROAD             | HANDA, JAPAN                  | 480m        |  | 2            | S    |
| 45 | 1974 | OHGISHIMA              | ROAD             | KAWASAKI, JAPAN               | 664m        |  | 2 x 2        | S    |
| 46 | 1975 | ELBE                   | ROAD             | HAMBURG GERMANY               | 1057m       |  | 3 x 2        | R    |
| 47 | 1975 | VLAKE                  | ROAD             | ZEELLAND NETHERLANDS          | 250m        |  | 2 x 3        | R    |
| 48 | 1975 | SUMIDA RIVER           | RAILWAY          | TOKYO                         | 201m        |  | 2 x 1        | S    |
| 49 | 1976 | HAMPTON ROADS (2)      | ROAD             | VIRGINIA, U.S.A               | 2229m       |  | 2            | S    |
| 50 | 1976 | PARIS METRO            | RAILWAY          | PARIS                         | 128m        |  | 2            | R    |
| 51 | 1976 | TOKYO PORT             | ROAD             | TOKYO                         | 1035m       |  | 2 x 3        | R    |

TABLE 16.4. WORLD LIST OF IMMERSSED TUBES

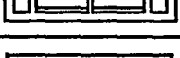
| No | YEAR | NAME                              | PURPOSE | LOCATION                 | TUBE LENGTH | CROSS-SECTION  | LANES/TRACKS | FORM |
|----|------|-----------------------------------|---------|--------------------------|-------------|--|--------------|------|
| 52 | 1977 | DRECHT                            | ROAD    | DORDRECHT<br>NETHERLANDS | 347m        |    | 4 x 2        | R    |
| 53 | 1978 | PRINSES MARGRIETT                 | ROAD    | SNEEK<br>NETHERLANDS     | 77m         |    | 2 x 3        | R    |
| 54 | 1978 | KILL                              | ROAD    | DORDRECHT<br>NETHERLANDS | 330m        |    | 2 x 3        | R    |
| 55 | 1979 | WASHINGTON CHANNEL                | RAILWAY | WASHINGTON D.C.<br>U.S.A | 311m        |    | 2 x 1        | S    |
| 56 | 1979 | KAWASAKI                          | ROAD    | KAWASAKI, JAPAN          | 840m        |    | 2 x 3        | S    |
| 57 | 1979 | HONG KONG<br>MASS TRANSIT RAILWAY | RAILWAY | HONG KONG                | 1400m       |    | 2 x 1        | R    |
| 58 | 1980 | HEMSPoor                          | RAILWAY | AMSTERDAM                | 1475m       |    | 3 x 1        | R    |
| 59 | 1980 | BOTLEK                            | ROAD    | ROTTERDAM<br>NETHERLANDS | 508m        |    | 2 x 3        | R    |
| 60 | 1980 | DAIBA                             | RAILWAY | TOKYO                    | 670m        |  | 2 x 1        | S    |
| 61 | 1980 | DAIKORO                           | ROAD    | TOKYO                    | 744m        |  | 2 x 2        | R    |
| 62 | 1982 | RUPEL                             | ROAD    | BOOM, BELGIUM            | 336m        |  | 2 x 3        | R    |
| 63 | 1984 | SPIJKENISSE                       | RAILWAY | ROTTERDAM                | 530m        |  | 2 x 1        | R    |
| 64 | 1984 | COOLHAVEN                         | RAILWAY | ROTTERDAM                | 412m        |  | 2 x 1        | R    |
| 65 | 1984 | KEOHSIUNG HARBOUR                 | ROAD    | TAIWAN                   | 1042m       |  | 2 x 2        | R    |
| 66 | 1985 | FORT McHENRY                      | ROAD    | BALTIMORE                | 1638m       |  | 4 x 2        | S    |
| 67 | 1986 | ELIZABETH RIVER (2)               | ROAD    | VIRGINIA                 | 762m        |  | 1 x 2        | S    |

## Notes:

1. Year is that of completion
2. \* Denotes part of underground railway system
3. Form of tunnel denotes thus:  
S- Steel shell  
R- Reinforced or prestressed concrete box

### C. Keohsiung Tunnel

The next tunnel to be completed was the four-lane road tunnel, linking parts of the large new harbor built at Keohsiung in Taiwan. This is 942 meters between portals, comprising 6x120 meters immersed-tube units and 156 and 166 meters long in-situ sections. The tunnel is of the traditional rectangular reinforced concrete box form, despite being built in proximity to large shipyards and steelworks, which might have been thought to favor the steel shell form (item 65).

The tunnel is of interest in several respects. For the construction, the Taiwan authorities issued specifications and outline designs and invited tenders for the development of the designs and for the provision of construction services to assist the Government contracting company, RSEA, in the building of the tunnel, these services primarily relating to the construction of the units, their handling and placing and their foundation.

As regards the units, those forming the 480 meters long section under the waterway were to be of minimal size in order to reduce their cost and minimize the depth of the tunnel, with the cross-sectional area of the traffic compartments being significantly smaller than that of the adjacent units and cut-and-cover sections under the banks each side. A longitudinal system of ventilation was postulated, with jet fans located in the ceiling of the cut-and-cover sections and adjacent units, but with none over the center 480 meters section. In this respect, the arrangement resembled that of the Rendsburg Tunnel, built under the Kiel Canal in West Germany in 1961 (item 17). However, in that case, the center section was 140 meters long and the length between portals 640 meters.

These differences are significant, particularly in that a typical spacing for jet fans would be about 100 meters, and it is necessary also to consider carefully the throttling effect of the reduced section upon the air flow under congested traffic conditions. In the case of Keohsiung, this was of special importance as large numbers of container trucks were to be expected and the design had to cope with these. It was not clear that it would do so satisfactorily under the proposed arrangement and, in any case, the fan power required was likely to be excessive.

The matter was resolved, following the assessment of tenders, by widening the traffic compartments so as to provide separate elevated ways for pedestrians and cyclists, with space for services beneath. This enlarged the cross-sectional area and reduced the throttling effect. The ventilation was provided by two banks of 30 kW jet fans located in the ceiling of the tunnel beneath the banks of the Waterway each side, i.e. 32 fans in all.

The central compartment, provided for services and pedestrians between the two traffic compartments, then became unnecessary and was eliminated.

#### **D. Fort McHenry Tunnel**

The Fort McHenry Tunnel, which carries the Interstate 95 Highway under Baltimore Harbor, is a notable example of large-scale construction work. It cost about USD 1000 million and took rather over five years to construct, being built within both program and budget.

The crossing was originally to be a bridge but this would have spanned across the historic Fort McHenry - where Francis Key wrote the US national anthem during the British bombardment in 1812 - and public opinion was so much against in that the more expensive tunnel solution had to be adopted. This controversy took place in the mid-70s and, interestingly enough, it was at this time that a similar controversy took place in this country over the crossing of the Conway in North Wales. The bridge scheme originally proposed would have ruined the environment of the medieval castle and, following much argument and a public enquiry, an immersed-tube solution was adopted.

The Fort McHenry Tunnel has eight lanes and 2020 meters between portals, with an immersed-tube length of 1650 meters and cut-and-cover sections each end. The maximum grade is 3.75 percent and the roadway at the nadir is some 27 meters below river level. The carriageway is 7.9 meters between kerbs, with 0.75 meters wide raised sidewalks, and the vertical clearance is 4.8 meters.

There are 16 pairs of immersed-tube units, each twox2-lane and about 105 meters long (item 66), the units being separated and lying side-by-side, about 3 meters apart, on a horizontal curve of mean radius 1050 meters. The units were, in fact, of similar size to those used for four-lane tunnels of this type and this was evidently considered more practical than using large single eight-lane units.

The form of the units to that used for the I-110 tunnel in Mobile (item 43) in that it has an outer shell box to contain the ballast concrete outer than that which is placed underneath and between the tubes. In this respect, it resembles most of the two-lane steel shell units. The other four-lane steel shell units, those for the first Baltimore Tunnel (item 13) and Hong Kong Cross-Harbor Tunnel (item 41) employ no outer box, all the ballast concrete being underneath and between the tubes. An argument in favor of the present form is that the shell, being completely surrounded by concrete, is better protected against corrosion. In the case of the Hong Kong Tunnel, the areas not so protected were covered with 65 mm of sprayed concrete; in the case of Baltimore such areas were left bare and, so far as is known, remain satisfactory.

In detail, the Fort McHenry units comprise a 8 mm thick mild steel shell, of 5.75 meters radius, stiffened externally by longitudinal flats or tees, generally 127x8 mm at 10<sup>2</sup> intervals and by 8 mm or 9.5 mm in diaphragms, generally at 4.52 meters intervals. The webs of the diaphragms are stiffened by 102 mmx8 mm plate, coinciding with the shell stiffeners, and the outer edges generally by 254 mmx9.5 mm flat. The external box is in 6.4 mm plate. The internal concrete ring is 0.5 meters thick, giving an internal radius of 5.26 meters. Typical ring reinforcement comprises 25.4 mm bars at 30.5 cm centers, with 12.7 mm at 30.5 cm centers longitudinally and 9.5 mm ties between the reinforcement and the inner face of the steel shell. The overall width of the units is 21.5 meters and height 12.8 meters.

These dimensions and plate sizes are fairly typical for this form of steel shell unit, but nevertheless one continues to be struck by the thinness of the plate and general economy of the section. The approximate quantities per m for the four-lane unit are 9.2 tones of steel plus 1.6 tones of reinforcement.

The steel shells were fabricated in a shipyard on the Susquehanna River, about 30 miles from Baltimore, and, after placing the 1.37 meters deep keel concrete, they were side-launched and towed to the site for sitting out. The units were sunk and placed in position in normal way, the foundation being the 61 cm thick screeded gravel bed traditionally used in the USA. The joints between units were, however, of the rubber gasket type used in Western Europe and it seems that this form of joint is now accepted in the USA.

The difference in practice between the USA and Western Europe, as to the form of immersed-tube, was discussed in the earlier articles and this difference continues in the recent tunnels. Tradition may play a part but it does seem that shipyards in the USA are able and willing to fabricate shells at reasonable prices and deliver them on time. For Fort McHenry it was adjudged that the steel shell form would be the most economic and tenders were not invited for the alternative reinforced concrete box form of units. Although the steel shell form has a good record in the USA, it would nevertheless have been interesting to have seen the results of alternative tenders for such units.

The fourx2-lane arrangement that was adopted for Fort McHenry suits the estimated traffic pattern, which has little directional peak-hour imbalance. Had a reinforced concrete box form of unit been used then the choice would have been between twin twox2-lane units, as was used for the steel shell form, and a single fourx2-lane unit. The alternative of four-lane traffic compartments has to be ruled out for structural reasons, apart from problems of ventilation.

The units may be compared with those of the Drecht Tunnel in Holland (item 52) which is a fourx2-lane rectangular reinforced concrete box type of immersed-tube.

The traffic compartments for Drecht are 10.35 meters wide and, with two 1.55 meters wide service ducts, the overall width of the units is 49 meters. This tunnel is, however, only 555 meters between portals and so a simple longitudinal ventilation system could be used, with booster fans in the traffic compartments.

The Fort McHenry tunnel is much longer, being 2020 meters between portals, and uses a fully transverse system for which air ducts have to be provided. In order to provide the equivalent air duct space, with 9.80 meters wide traffic compartments, the rectangular box units would have had to be about 60 meters wide. This would have been 11 meters wider than the Drecht units, which are the widest to date. Such units would clearly be unwieldy to handle and one would only choose to use them in sheltered conditions. The alternative twin twox2-lane Rc box units would have been about 32 meters wide. These would have been of conventional size and would not normally pose any significant difficulty.

### **E. Third Elizabeth River Tunnel**

The third Elizabeth River Tunnel lies under the Elizabeth River in Portsmouth, Virginia, and duplicates the existing immersed-tube some 60 meters upstream, which was completed in 1952 (item 11). A third immersed-tube under this river lies some two miles downstream and was completed in 1962 (item 19).

All three tunnels are two-lane and of the steel shell type but, whereas the two earlier tunnels were of the normal circular shape, the recent tunnel is of horseshoe shape. This has been proposed for several immersed-tube tunnels in the past and is a logical development where the space under the roadway is not required. The unit is cheaper, easier to handle and less dredging is required. In the case of this tunnel, the shape was possible because a semi-transverse system of ventilation was used, fresh air entering at the portals and vitiated air being withdrawn via an exhaust duct above the ceiling of the roadway.

Both this and earlier tunnel each have a single ventilation building, located at one of the portals. The width between kerbs in the first tunnel is 6.7 meters but this has been increased to 7.9 meters for the second. In both cases the general gradient is 5 percent. There are eight units, of lengths between 86 and 110 meters, the structural details being similar to those described for the Fort McHenry units except that the base slab is flat and 1.2 meters thick and the units are 12.2 meters wide.

The units were fabricated at a yard at Corpus Christi, Texas, some 2000 miles (3200 km) from the site. They were then skidded on to a large flat-top barge and, after placing the base concrete, they were carried by the barge, two at a time, to the site. There

they were unloaded, using a large floating dock, prior to being towed away for fitting out. The barge then returned to Texas for the next pair.

This operation gives an interesting picture of the scale of the resources available within the USA and the freedom with which they can be deployed for such work. Within western Europe it would be as though shipyards in Northern Italy were to fabricate steel shells for a tunnel in Southern England, or shipyards on the Clyde to do so far a tunnel in Majorca.

The point is some of importance in considering the use of steel shell units fabricated in shipyards. One of the major difficulties in this is to ensure that there would be a shipyard able and willing to fabricate the units when they were required, bearing in mind the uncertainties of timing that often apply not only to civil engineering projects but also to orders placed for ship-building. This makes it difficult to plan to use particular yards, especially if competitive tenders are required. With the scale and freedom of choice available in the USA such difficulties are greatly reduced, for it is likely, within such a large country, that several yards could be found who could undertake the work. These conditions could apply in Western Europe if countries were to forego preference for their own yards and this might make the steel shell a more attractive alternative there in the appropriate circumstances.

## 17. IMMERSED FLOATING TUNNELS

### 17.1. Introduction

Immersed floating tunnels are tunnels that are suspended above the sea bottom. Their cross section is selected such that the resulting buoyant force exceeds the dead load of the structure and imposed live loads thereby allowing the tunnel to float above the sea bottom. Vertical equilibrium and position are maintained by cables or pipes connected from the tube to the sea bottom [34].

Although engineers have romanticized about immersed floating tunnels for nearly 50 years, it has not been until recently that serious thought has been directed at this concept. The increased attention most probably is due to the recent successes by the offshore petroleum industry in the construction of tension leg platforms - a concept with many similarities to immersed floating tunnels.

### 17.2. Loading Considerations

The loads to which immersed floating tunnels will be subjected to can be categorized into three groups [34]:

- (a) functional loads;
- (b) environmental loads;
- (c) accidental loads.

Functional loads include the dead load of the structure and live loads from traffic. Environmental loads include currents, waves, tides, changes in water density, marine growth and in some areas ice loading. Accidental loads include seismic loads, ship collision, explosions within the tunnel and anchor failure.

Functional loads can be reliably predicted. environmental loads can also be predicted with fairly good certainty. Further, several measures can be introduced into the design which minimizes the influence of environmental loads. These include establishing the tunnel profile at sufficient depth in order to reduce the current that the tube would be subjected to. Judicious selection of a profile would also minimize the variation in fluid density that the structure would be exposed to.

On the other hand, accidental loads are difficult to predict and therefore difficult to design for. Nevertheless, sufficient conservatism can be built into the design such that the risks associated with accidental loads can be reduced to normally acceptable levels. Features which may be introduced into the design include providing an internal and external steel shell in order to maintain water tightness in the event of an explosion or ship collision. Similar to minimizing environmental effects by lowering the profile, potential for ship collision can be mitigated by setting the profile to provide sufficient clearance to permit the largest of vessels to pass over unencumbered.

Consideration could also be given to providing two redundant but different anchorage systems such as piled anchors and gravity anchors. Each anchorage system would be designed to carry the full load in the unlikely event of a complete failure of one of the systems.

### 17.3. Tunnel Cross Section

The tunnel cross section will be dependent on several items including the function needs (number of travelways or rail tracks ), the method selected to construct the tunnel, ventilation requirements, the selected construction materials and the anticipated loadings. A two lane road tunnel could resemble a circular cylinder. A two track rail tunnel could resemble a binocular shape similar to that shown in *Figure 17.1* for the Bay Area Rapid Transit (BART) Immersed Tube Tunnel in the USA [34].

Conventional immersed tunnels have been constructed either of concrete or concrete composite with steel shells. The two Tension Leg Platforms (TLP) in operation, the Hutton TLP in the North Sea and the Jolliet TLWP in the Gulf of Mexico are both constructed of steel. However, the proposed TLP for the Heidrun Field in the Norwegian sector of the North Sea consists of a concrete hull. Therefore, it is anticipated that a submerged floating tunnel can be constructed from either material.

A major influence on the cross section will be the selection of the tendon system. Several potential systems are possible. One system involves installation from within the tube while the tube is either floating on the surface prior to placement or while the tube is

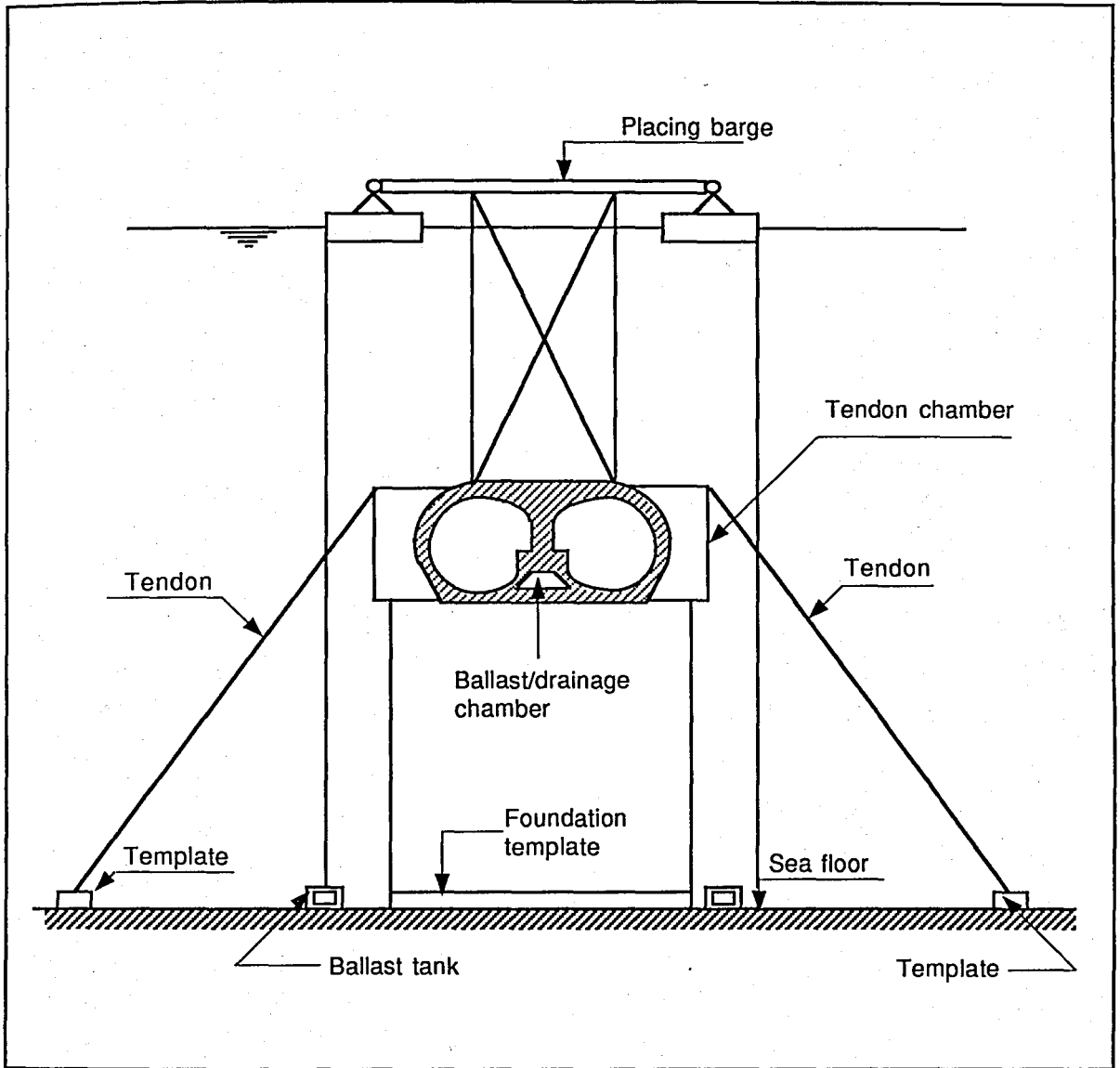

FIGURE 17.1. IMMERSSED FLOATING TUNNEL WITH TENDON CHAMBER

either floating on the surface prior to placement or while the tube is suspended in close proximity to its final location. An internal anchorage installation method was utilized for the Hutton TLP, chambers would be required within the bottom of the tube or on its sides.

Typical immersed tube casting and fabrication methods in use today indicate that this chamber would most probably be located on the sides of the tunnel (See *Figure 17.1*). These chambers would house the tendon sections, tendon handling equipment and tendon load measuring equipment. Two to four chambers would be required per tube section. Access to the chamber would have to be from within the tube.

This arrangement has several positive features:

- (a) allows for easy and rapid replacement of tendons from within the chamber;
- (b) allows for regular inspection of the tendons by passing sensors down the center of the tendon from within the chamber;

These chambers however have several negative aspects including:

- (a) Expensive handling equipment would be required in each chamber.
- (b) Construction of the chamber will require costly changes in the structural cross section.

A second potential tendon system, similar to that utilized in construction of the recently completed Jolliet TLP in the Gulf of Mexico, involves tendons fabricated in one single section. These would be towed out to the construction site by several tug boats and once at the project site, the tendon's top connector would be attached to a cable which passes over a pulley mounted on the tube section as shown in *Figure 17.2*. A second cable from the opposite end of the tendon would be attached to the foundation template by remotely operated vehicles (ROVs).

The cables serve to guide the tendon into its proper position on the foundation template. This system has several attractive features including:

- (a) simple, relatively inexpensive tendon handling equipment;
- (b) rapid installation of the tendons;
- (c) minor structural variations in the tunnel cross section.

Some of the negative features associated with this system include:

- (a) Inability to inspect the tendon (other than visually by ROV).
- (b) Tendon replacement would require use of surface vessels and equipment and therefore could not be done rapidly.

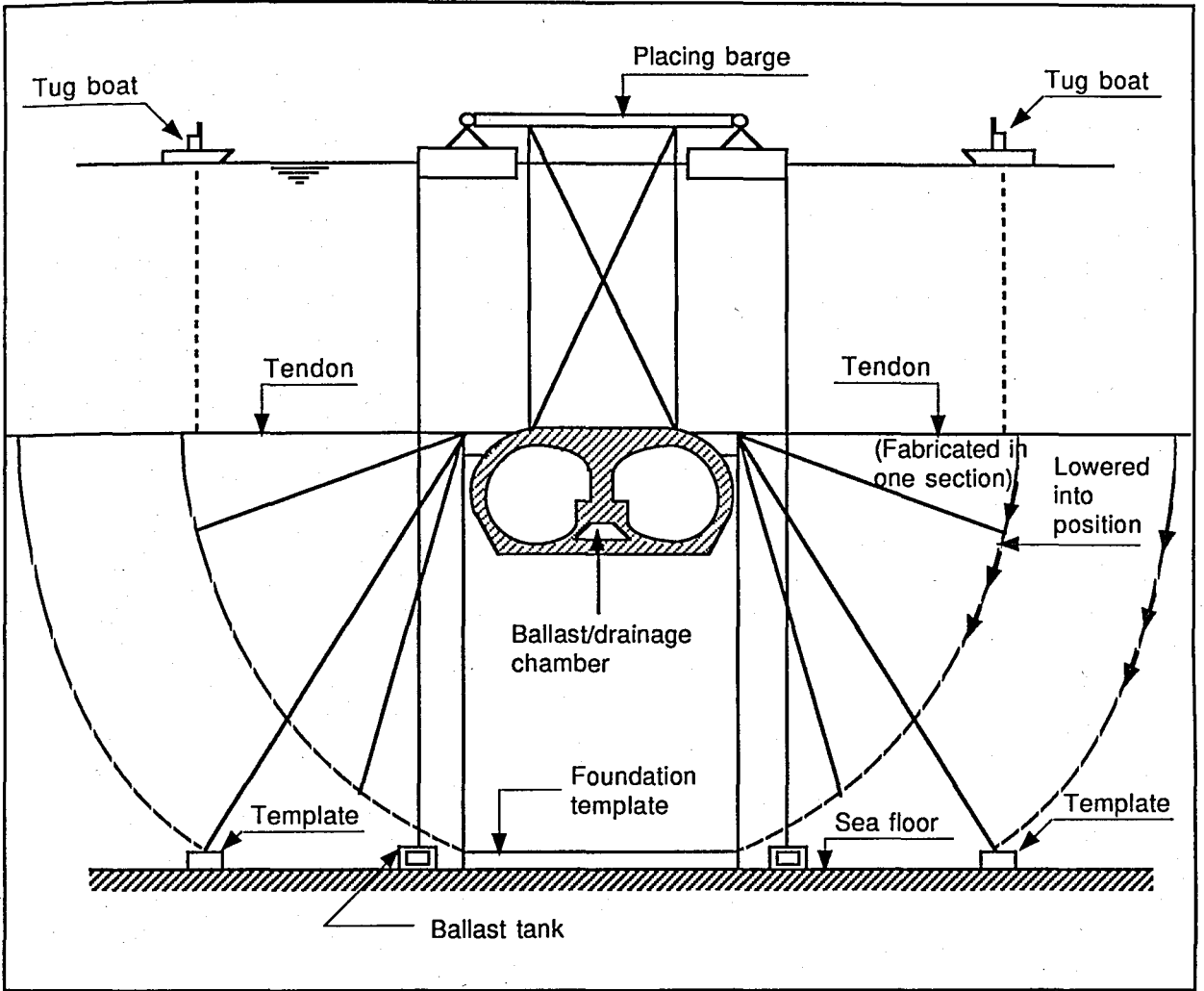

FIGURE 17.2. TENDONS INSTALLED FROM OUTSIDE

## 17.4. Tube Placing and Joining Methods

Conventional tube placing and joining methods can also be utilized for immersed floating tunnels. The tube would be fabricated offside and towed to the construction site after concrete outfitting is completed. Once at the construction site the tube would be positioned within a placing barge. The placing barge would be held in position by several fluid filled gravity anchors which would be deballasted and removed once the tube is placed.

With the tube in floatation and held within the placing barge, tendon elements would be installed from within the tube to the required total length. Workers would access the tunnel through the end bulkhead doors and would be evacuated once the tendons are installed. Ballast pockets within the tube would then be flooded with water transferring vertical load to the placing barge. The placing barge would slowly lower the tube to the required depth. The tendons could then be either "stabbed" in to the foundation template (similar to what was done on the Hutton TLP) or engaged by the lowering process. Once the tendons are connected to the foundation, the tube would be deballasted causing load to transfer from the placing barge to the tendon system.

Hydraulic couplers located on the previously placed tube would then be extended to and engaged with the just placed tube. The hydraulic couplers would then be retracted pulling the tube into place. An initial watertight seal would be provided by a Gina gasket or the double trapezoidal gasket commonly used in the U.S. End bulkhead doors would then be opened and the permanent joint between the two tubes constructed.

An alternative placing method would consist of lowering the tube to the required depth without the tendons installed. Once at the required depth the tendons would be installed and engaged with the foundation template. However, this method would require that workers remain within the tube during the entire operation. This is considered risky and without any clear advantages.

In the case of tendons installed from outside the tube, the tube and tendons would be towed out separately to the construction site. At the site, one end of the tendon would be connected to the tube. The tendons would then be lowered slightly to clear the barge. The tube would then be positioned within the placing barge. The ballast pockets would then be flooded thereby transferring load to the placing barge.

Remotely operated vehicles (ROVs) would be utilized to install a guide cable to the foundation template. As the tube is lowered the tendons would also be lowered. Once the tube is in its proper location and the tendons at their proper position within the foundation template, the tube would be deballasted thereby locking the tendons into position and

transferring load from the placing barge to the tendon system. The tubes would then be joined in a manner similar to that described above.

## 17.5. Foundation System

There are several possible foundation systems which may be utilized to secure immersed floating tunnels to the sea bottom. These would include gravity anchors, drilled and grouted piles, driven piles and grouted driven piles [34], [35]. Selection of the appropriate system will depend on the specific site geology. driven piles were utilized on the Hutton TLP to connect the foundation template to the sea bottom. The foundation template for a immersed floating tunnel could be very similar to that utilized on TLPs. The template would be fabricated of steel and consist of several pile sleeves and tendon receptacles. It is suggested that additional tendon receptacles be provided to facilitate tendon replacement.

The Hutton TLP utilized four separate templates one at each tendon grouping. The proper relative locations of each of the templates was ensured by utilizing a template guide frame.

The guide frame would be equipped with receptacles for the foundation templates and also for a subsequent guide frame. The guide frame would be placed first and locked into position by piles. The foundation templates would then be lowered into position and piles installed. A second or subsequent guide frame would then be lowered into position and piles installed. A second or subsequent guide frame would then be lowered and attached to the first, thereby ensuring the proper orientation of its foundation templates with those placed for the previous tube. This sequence would continue until all templates are installed as shown in *Figure 17.3*. Details could be developed which allow for the reuse of the guide frames.

## 17.6. Conclusions

Sufficient technological advancements have been made which now make immersed floating tunnels feasible. Recent advances by the petroleum industry have demonstrated that installation of offshore oil exploration and production platforms can be accomplished in water depths in excess of 300 meters. These advances, conventional immersed tube design and construction practices, demonstrate that construction of immersed floating tunnels is now only a matter of time.

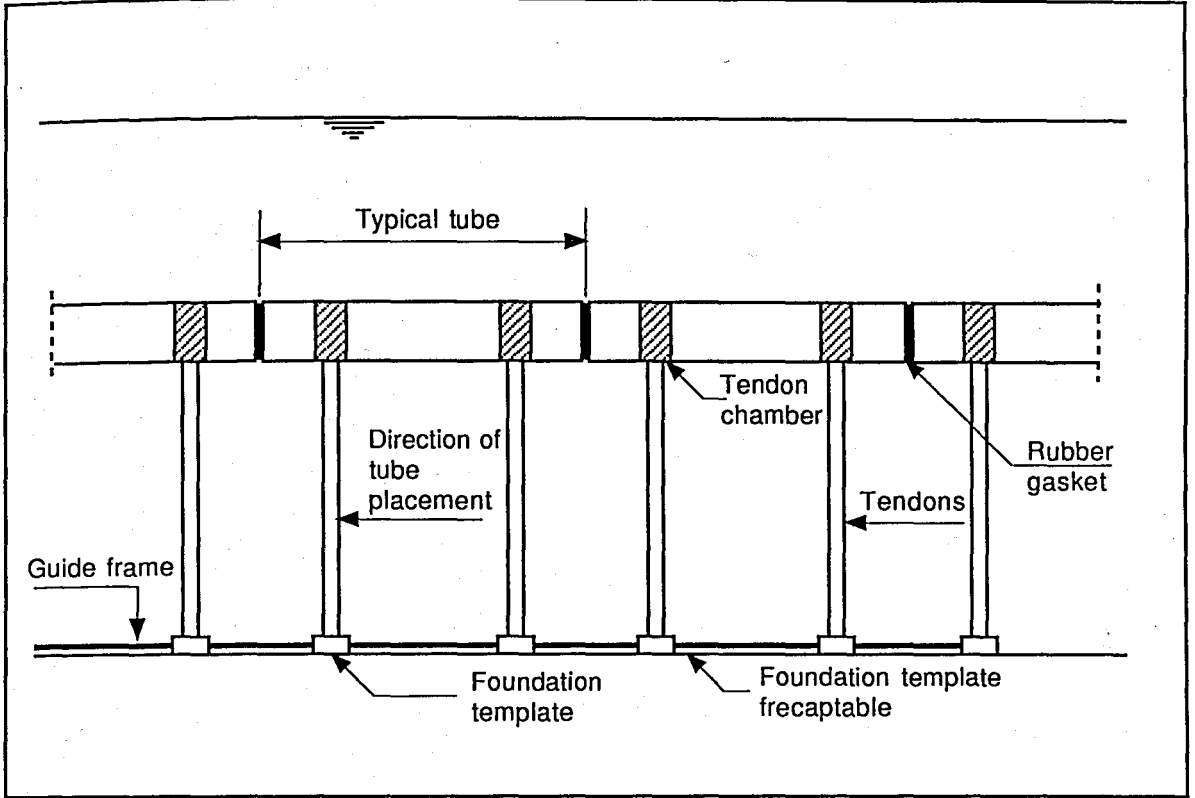

FIGURE 17.3. LONGITUDINAL ELEVATION

## 18. ROCK TUNNELING

### 18.1. Types of Rock and Rock Structure

Varieties of rock are so numerous that only a broad description of loading types is possible here. The borderline between soft ground and rock for present poses is where pick and shovel, or their modern equivalent, must give way to use of explosives [36].

Geological terminology is essential to description of rocks and their structure as encountered in a tunnel. The broad classification based on the mode of formation is into sedimentary, igneous and metamorphic rocks.

*Sedimentary rocks*, originally laid down horizontally under water and subsequently consolidated and cemented together, include sandstones, shales, mudstones and limestones. Beds may be thin and variable, or massive and relatively homogeneous. They are normally traversed by systems of vertical joints, whose spacing and characteristics govern the way in which the rock breaks up and the degree to which it is self-supporting when excavated. Shales in particular tend to fragment readily and to require much more support than does a massive sandstone. Limestones are typically well jointed : they may be thin, alternating with shales and sandstones, or thick and massive. Their solubility in acidic water can result in enlargement of fissures into vast caverns through which water flows.

Sandstones are in origin shallow-water sediments. They are frequently massive and very uniform, but may be 'current-bedded', the arrangement, sequence and grading of beds being irregular. Sandstones contain a high proportion of quartz grains, which are hard and abrasive.

*Igneous rocks* of molten origin range from 'plutonic' rocks, such as granite, intruded at great depth and having a coarse crystalline structure developed during slow cooling, to

surface lavas, of which basalt is typical with its fine crystalline texture. Pyroclastic material is that which has been ejected from a volcano through the atmosphere and deposited on the surface ; it includes volcanic ash or 'tuff'.

In massive granites the main tunneling problem is that of breaking out the rock, which is largely or entirely self supporting. Basalts are less uniform, and usually in thinner beds, requiring more varied techniques of excavation and support. In all cases deep penetration of weathering over long periods may cause disintegration of the crystalline structure. Pyroclastic deposits are likely to be variable and to lack consistent cohesive properties, demanding therefore continues study of requirements for support.

*Metamorphic rocks* are usually ancient rocks of sedimentary or igneous origin, which have been substantially modified by heat, pressure and deformation. Tunneling types will range from massive gneiss, resembling coarse granite, to mica schists, cleaving readily on parallel planes. In general, metamorphic rocks are of varied texture and embody discontinuities caused by stress and deformation. They are typical of mountain folding, and, where relatively new, may not be fully consolidated, so that bands of shattered rock or squeezing rock may be encountered, and physical or chemical instability may develop because of the changes caused by excavation.

## 18.2. Bedding and Jointing

Bedding and jointing are important as constituting planes of weakness encountered in tunneling. Bed joints are those, originally horizontal, separating changes in lithology. They are defined in terms of 'dip', the angle of slope from horizontal, and 'strike', the orientation of a level line lying in the plane of the bed joint. Jointing, within a bed, or stratum, is normally at right angles to the plane of the bed, and may be characterized by a principal set of joints, in parallel planes and more or less uniformly spaced, intersected by one or more minor sets of joints.

In driving a tunnel, the direction of drive relative to the dip and strike and the joint pattern will determine the way in which the rock in roof, sides and face tends to fracture as shown in *Figure 18.1*. Much depends on the cohesion in bed and other joints and on the presence of water, sometimes functioning as a lubricant.

Also of importance is the presence of a 'fault', the geological term for relative shearing displacement of the strata. The most usual form is that where the strata, on one side of a near-vertical plane, have dropped down relative to the strata on the other side. The 'throw' may be a few centimeters, or may be meters.

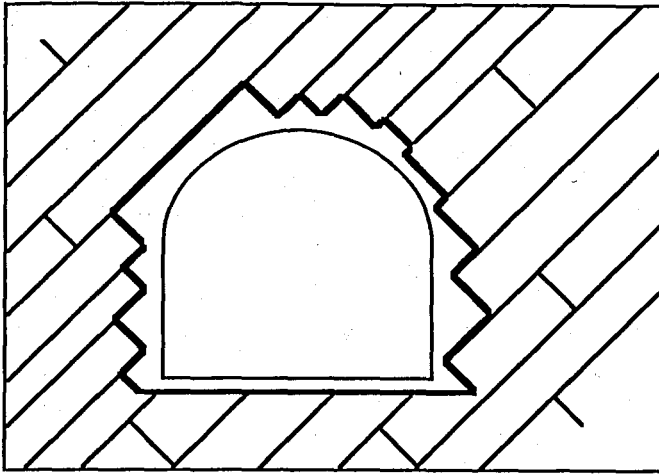

(a) Dip across tunnel

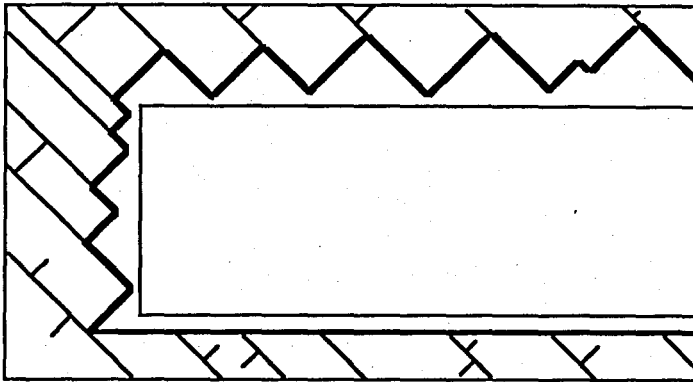

(b) Tunnel following in direction of dip

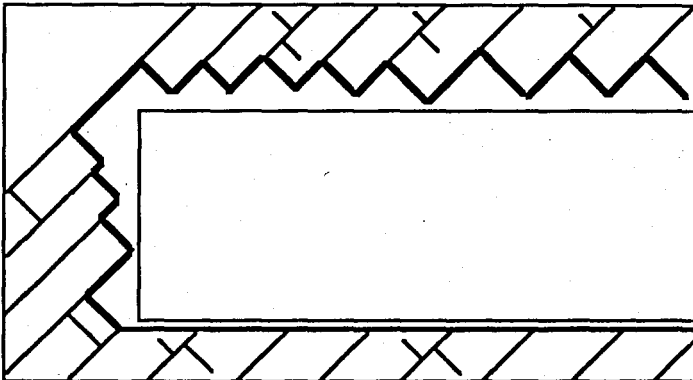

(c) Tunnel driven against direction of dip

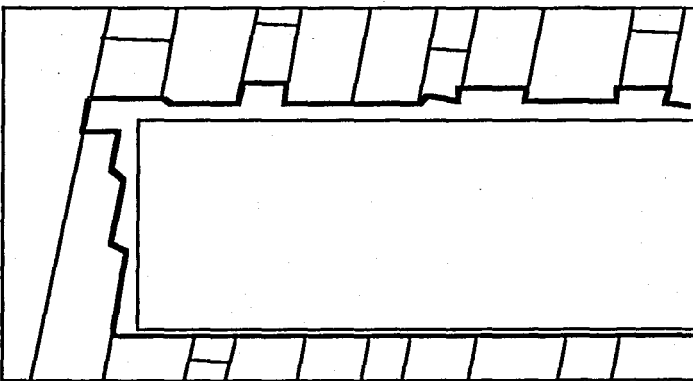

(d) Tunnel driven with near-vertical dip

FIGURE 18.1. DIP STRATA IN RELATION TO TUNNEL EXCAVATION

The subject of rock mechanics deals with the behavior under stress of rock and rock structures. To provide the necessary data for prediction the first requirement is a series of core borings, from which the detailed characteristics of the rock can be ascertained, in conjunction with as accurate a survey as practicable of geological structure and joint patterns. The possible action of water in lubricating joints and in washing out fine material must not be neglected.

### **18.3. Drill-and-Blast Cycle**

Advance of a rock tunnel is a cyclic operation following the sequence drill face, charge, detonate, ventilate, bar down, muck out, support. There is an optimum length of advance, or 'pull', for any tunnel dependent on the nature of the rock, the safe length and timing for supports, the system of muck disposal, and the length of a shift.

The tunnel roof is supported naturally by arching action across its width and forwards. Blasting destroys the support at the face and initiates a change in the stress pattern above, which may reach stability quickly or may so develop as to result in continuing rock falls.

A proper appreciation of these factors determines the choice of support system, most usually in the form of steel arch ribs, packed with timber, or otherwise, to provide uniform bearing. Until the spoil from blasting has been cleared supports cannot be fixed, and therefore the capacity of the disposal system must be adequate to handle the volume of material, proportional to length of pull. The reference to length of shift concerns the advantage of ensuring that the changeover occurs consistently at a convenient point in the cycle. In smaller tunnels excavation is likely to be on the full face, but in larger tunnels it is often found advantageous to advance first the upper half of the face, leaving a bench, and to follow by excavating the bench as a separate phase of the cycle.

#### **A. Drilling**

The drilling of a pattern of holes is by means of pneumatic or hydraulic rock drills, which in a small tunnel may be lightweight tools, hand-held but with a supporting leg, or for a large face may be a battery of heavy 'drifters' mounted on a 'jumbo' drilling gantry. The depth of drilling is likely to be 2m or more.

Holes are drilled horizontally forward in a pattern designed to suit the rock and to provide convenient fragmentation. They comprise cut holes, to blast an initial cavity; cut spreader holes; perimeter holes, to trim the tunnel to the required profile; lifter, or floor,

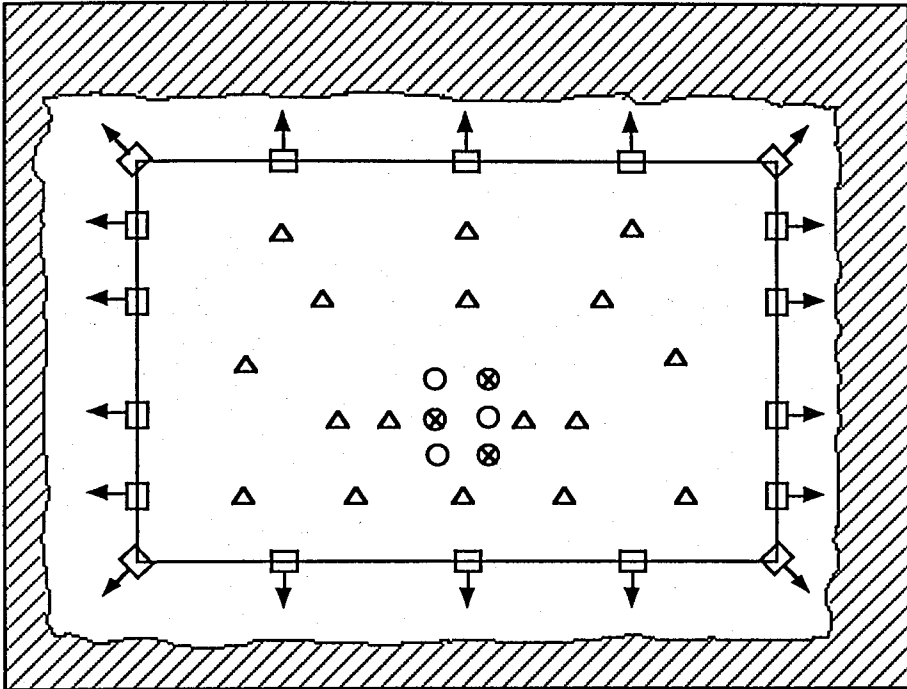

(a) Box type burn cut

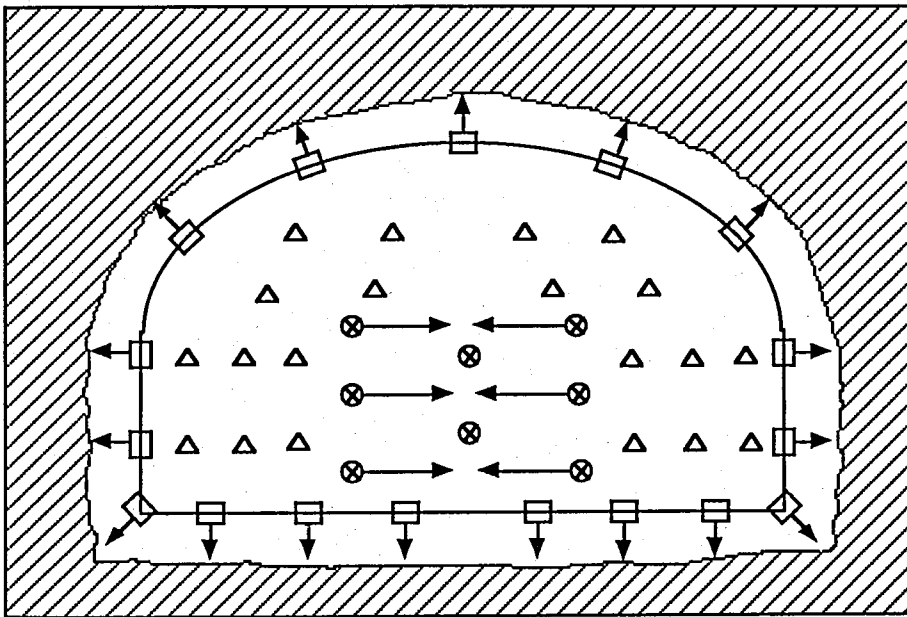

(b) Wedge cut

- Uncharged holes
- ⊗ Cut holes
- ⊗→ Included cut holes
- △ Cut spreader holes
- Perimeter holes and lifter holes

FIGURE 18.2. DRILLING PATTERNS

holes, immediately above floor level; and possibly easier holes, which are left uncharged, and are drilled to help in controlling the breakage as indicated in *Figure 18.2*.

## **B. Charging and Firing**

The holes are charged with appropriate quantities of explosive and each is fitted with an electrically ignited detonator. The detonators and firing circuits are so arranged that charges are fired successively and not simultaneously. All men are withdrawn to a safe distance before firing, which is the responsibility of a named man. After firing, toxic fumes must be extracted, or amply diluted, by the ventilation systems before men may return to the face, where the first operation is inspection and barring down of any dangerously loose rock. This is followed by mucking out, and installation of supports.

### **18.4. Support Systems**

The use of a steel arches is described above for any immediate support required. Sprayed concrete, additionally or in substitution, is a useful system. Another support technique is the installation of rock bolts, either to a systematic pattern in the roof, or wherever the stability of the rock is doubtful.

Permanent support is usually by in situ concrete lining. It may follow far behind excavation, as a separately organized operation. It requires lengths of carefully planned collapsible shuttering and often the use of concrete pumps or concrete placers.

The term 'stand-up time' is used for rock tunneling. It is sometimes called the 'bridge action period'. It is a function of rock type and structure in combination with unsupported span and support technique as shown in *Figure 18.3*. Times ranging from 20 minutes on a span of 8.8 meters in very friable rock to 20 years on a span of 4 meters in solid rock have been tabulated.

The assessment of rock quality and its correlation with behavior in a tunnel has been the subject of much study, but it remains very difficult to secure any objective system of general application.

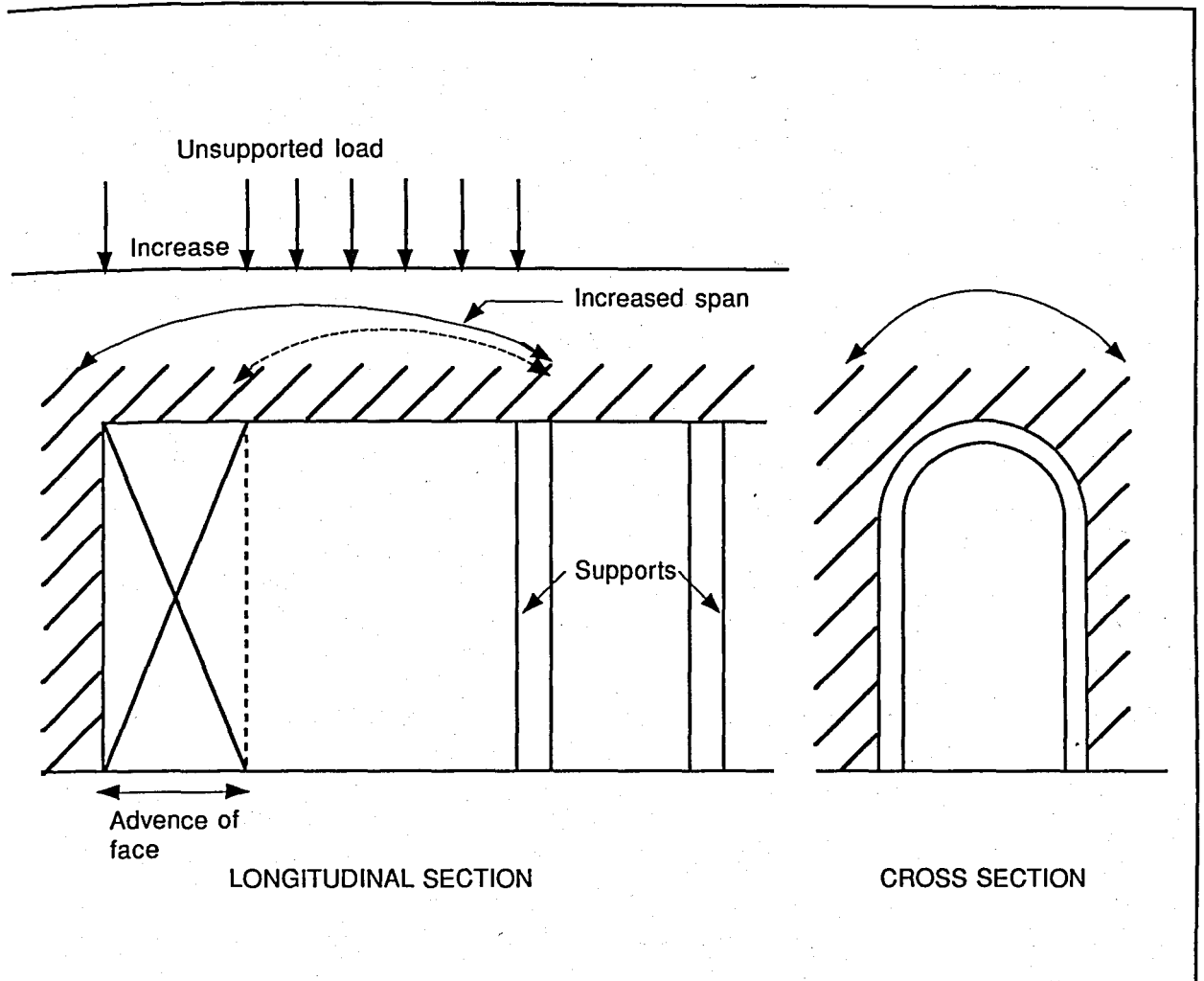

FIGURE 18.3. INCREASE OF LOAD AS FACE IS ADVANCED

## 18.5. Cavern Storage

The construction of large underground caverns for storage or for housing hydroelectric generating equipment extends tunneling methods into a field beyond that of ordinary tunnels of passage. Security, economy and amenity are the prime objectives of such caverns. Apart from power stations, their widest use is probably for storage of oil, but in favorable ground conditions they are used for such diverse purposes as cold storage, sewage treatment, gas storage, pumped energy storage (water or compressed air), military storage and disposal of nuclear waste.

As compared with the tunneling already described, the special features and requirements are the large size of the caverns are the minimal use of lining and added support. Because of these factors, it becomes of importance to ensure in advance detailed study of the geology of the whole space involved, and investigation of rock properties and structures in terms of rock mechanics. Massive rock, free from faults or other discontinuities, is to be sought.

Excavation is likely to be with explosives, with particular care being taken to cut precisely to the desired profile with minimal disturbance of the rock structure outside the perimeter. The main load must be carried by arching of the remaining rock, possibly assisted by rock bolting and sprayed concrete. Monitoring of behavior during construction may be quite elaborate and can give valuable guidance. In oil storage in unlined rock it is important that an effective water table is maintained to above roof level so that the lighter oil is contained by surrounding water.

## 18.6. Ancillary Operations in Rock

### A. Rock bolting

Rock bolts are used principally in the roof of a tunnel to give added strength. In most cases the bolts are stressed in tension, but occasionally may function as unstressed dowel rods; the use of timber is sometimes preferred for temporary support if the rock is to be cut out by machine. Bolt holes are drilled up into the rock, normally at right angles to the bedding planes. The bolts are anchored at the end by a wedge or other expanding device, and are tensioned against the face of the rock by a plate and nut. Unless temporary, the bolt is grouted in, usually with cement grout, but in some circumstances with epoxy resin.

The first, obvious, action of rock bolts is to hold up insecure blocks of rock, but an even more valuable function is that the compressing of layers across the joints integrates the rock elements and allows beam action and arching action to develop.

Bolts are generally 25mm or more in diameter and 2m upwards in length. A pattern of bolts, at a spacing of 1m or more, is designed to suit the ground. Adequate length to ensure that the end anchorage is in sound rock is, of course, essential.

## **B. Sprayed Concrete**

The use of sprayed concrete, applied directly to the newly exposed and trimmed surface of the rock in a tunnel, is a method of providing immediate and continuing support. It is an essential feature of the New Austrian Tunneling Method (NATM). Concrete, mixed from aggregate up to about 25mm and cement, is sprayed under pressure from a 'gun'. Water in the mix may be added initially or at the point of ejection. The mix must be carefully and accurately proportioned with close control of the water/cement ratio.

The cement grout is forced into fissures and fine cracks in the rock face, and a layer of concrete is built up over the face to any desired thickness. The effect of this is to minimize movement and disintegration of the rock, somewhat shattered by blasting, and to integrate rock and concrete so that arching action may develop and provide support. The flexibility of the thin layer of concrete allows it to accommodate to the strains and deflections in the rock without developing large bending moments causing cracking. Reinforcing steel may be incorporated in the concrete. The skill and judgment of the operators are important in effective application and in minimizing losses of material as 'rebound'.

## 19. CUT AND COVER TUNNELS

### 19.1. Characteristics

Construction of a tunnel by cut-and-cover offers an alternative to boring where a trench of the required depth and width can be excavated from the surface . In its simplest form, a trench is excavated, the tunnel structure is built , the trench is backfilled and the surface is restored, but the support of soft ground and the maintenance of existing surface and underground facilities and services make most projects much more complex [36].

For shallow tunnels the direct cost of cut-and-cover is likely to be much less than the cost of boring, but the incidental costs can change the balance completely. These include such costs, not always ascertainable or necessarily chargeable, as provision of alternative facilities for traffic using the surface, safeguards against subsidence, protection or diversion of services and drainage systems and social costs of disruption and loss of amenity.

With increasing depth, direct costs of trench excavation and support increase rapidly. In water-bearing ground the water must be managed by containment, pumping or ground water lowering, while, in soft clays particularly, heave of the trench bottom may lead to serious loss of ground and subsidence.

For Undersea tunneling cut-and-cover method is employed in subaqueous tunnels to form a transition between an open cut approach and the main tunnel.

## 19.2. Subaqueous Tunnels

In subaqueous tunnels shown in *Figure 19.1*, a transition may connect an open approach ramp with a shield bored or immersed unit tunnel. At the outer end the preference for a covered tunnel over open cut may arise from [36]:

- (a) construction problems and costs for open cut;
- (b) need to restore surface use over the tunnel ; and
- (c) danger of flooding.

In the vicinity of a river the ground is usually alluvial such as soft silts and clays, water-bearing gravels with perhaps peaty layers. Any trench excavation will require substantial lateral support and management of water with precautions against bottom heave. While temporary support for a Working trench may be feasible, permanent retaining walls and their foundations may become unduly heavy and costly and require such top strutting that a closed box structure is preferable. Upward water pressure acting on the base of an open cut may have to be counteracted by downward loading, more economically provided by backfill over a tunnel roof.

In open country a road or railway close to the river bank may pass across the tunnel approach at ground level or a flood bank may have to be restored. Drainage systems, whether in open channels or pipes, might be obstructed by a cutting. In urban conditions, the surface requirements are as more fully discussed below.

Protection against flooding by abnormal tides may be more satisfactorily given by roofing over than by high flood banks or walls. Where construction is in a cofferdam extending into the waterway the need for a roofed structure is obvious.

For submerged unit tunnels sufficient depth for flotation is critical, but that is determined by the practicability and economy of dredging. An interesting case was in early metro line in Amsterdam where a canal was dredged along a wide approach highway allowing units to be floated in, sunk and joined. It is understood that the scale of excavation and disruption proved to be unacceptable and the method has not been used subsequently. The maintenance of essential services and utilities must have been another major problem.

In shield tunneling a minimum of a few meters above the shield is desirable, the depth depending on the cohesive character of the ground and the presence of water. Where compressed air working is employed the overburden must be at least sufficient to retain the necessary air pressure, although the drive can be extended landwards on a rising gradient by building a temporary bank to provide the required loading. The highest level to which a shield is driven may also be limited by the need for a stratum at the invert

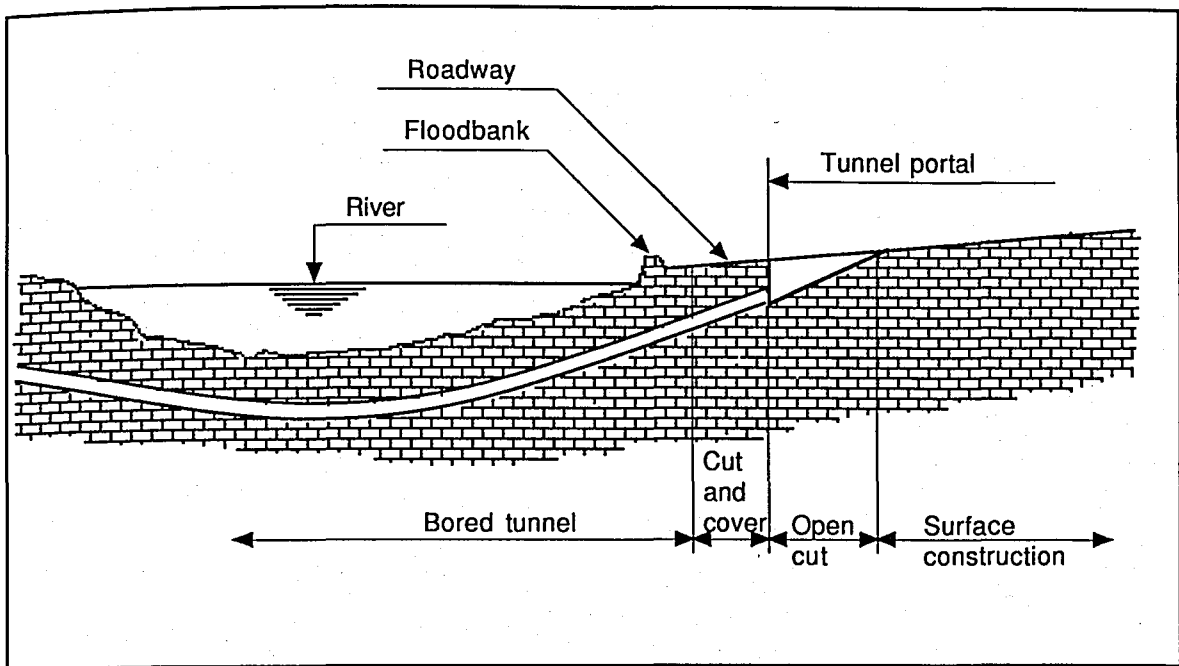

FIGURE 19.1. SUBAQUEOUS TUNNEL

sufficiently firm to support the weight of the shield and to allow its level and attitude to be controlled.

It is frequently found convenient to site a ventilation station, possibly by caisson construction, at the transition from main tunnel to cut-and-cover.

### 19.3. Techniques of Construction

The key to the various methods lies largely in the support of the vertical sides. The principle techniques include [36]:

- (a) steel sheet piling with wallings and struts or ground anchors;
- (b) ground anchors;
- (c) king piles with struts or ground anchors and horizontal piling boards;
- (d) slurry trench walls;
- (e) large diameter bored piles contiguous or overlapping;
- (f) concrete walls in heading .

The choice of method will be determined by the nature of the ground, the assessment of the difficulties, available resources, cost of construction, land costs and social costs.

#### A. Steel Sheet Piling

This is the simplest engineering solution in soft ground provided it is free from obstructions natural or artificial, such as boulders or cellars and foundations or service pipes leading to and from buildings: the piling requires to be supported as excavation proceeds by wallings and struts forming a framework wedged into place. Section of sheet piling with walling and ground anchors is shown in *Figure 19.2*. Struts across the trench make access for excavation difficult: ground anchors are a possible alternative.

The vertical intervals between frames are calculated initially to give acceptable stresses and deflections in the piles but even when set and wedged tightly as early as possible some deformation of the ground will occur as noted above, because of ground stresses and plastic flow as the trench is deepened. Movement can be reduced by imposed loading in struts or prestressing in anchor cables, but the flexibility of the steel sheet piling makes unavoidable some loss of ground and resultant settlement, which may or may not be within acceptable limits at the distance from the piling of the nearest structure. Another possible source of settlement is the compaction of loose granular soil resulting from vibration.

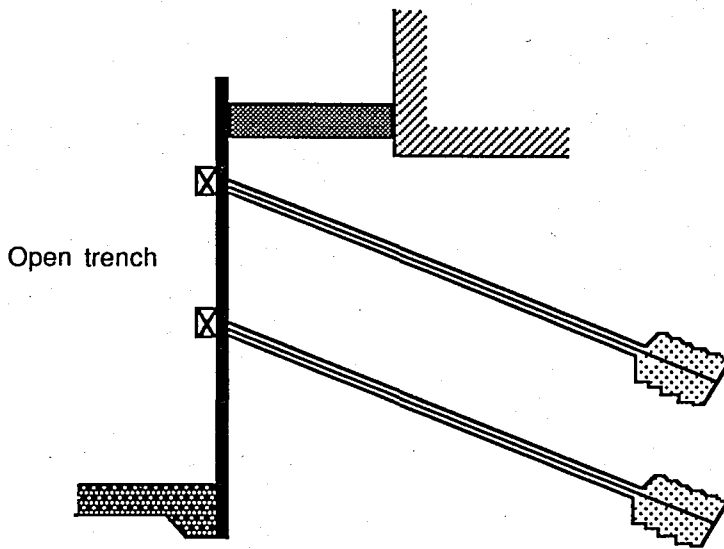

FIGURE 19.2. SECTION OF SHEET PILING WITH WALINGS AND GROUND ANCHORS

Pile driving by hammer is a noisy operation but relatively quiet methods have been developed. Headroom for pitching a line of piles may not be available, particularly in city streets, where there are overhead wires, or where close to buildings.

Steel sheet piling provides an effective temporary barrier to water except where piles get distorted and out of clutch. In water-bearing ground this may necessitate remedial measures such as local ground injection treatment or, possibly, additional piles. Watertightness of the piling is rarely adequate for permanent tunnel requirements. The piling must frequently be left in space although the tops may be burned off at some stage of excavation and backfill.

## **B. Ground Anchors**

One great merit of ground anchors is that they avoid any obstruction of the trench by struts. Another is that they can be readily prestressed. They do, however, extend usually far behind the line of the wall, and very probably beyond the limits of acquisition of land. It will then be necessary first to verify that the anchorages are clear of basements or other structures, and then to obtain permission from the adjacent property owners. For tunnel construction the use of ground anchors will almost certainly be temporary, until the tunnel roof is in place and acts as a strut. If, for any reason, permanent anchorages are required, they would have to be fully protected, not only against corrosion, but against disturbance or damage caused by future site development.

## **C. King Piles**

An alternative is the use of bored king piles at regular spacing as shown in *Figure 19.3*. They may be of heavy section steel lowered into a pre-bored hole. Where rock is present at suitable depth the toe can be grouted into the rock. The piles will require strutting across the trench as excavation proceeds, but ground anchors, prestressed if necessary, will minimize obstruction of the area of excavation. The ground between the piles is supported by horizontal poling boards set in place as excavation proceeds. A variant is where a length of wall is concreted in a slurry filled trench excavated between the king piles. The piles can be designed to carry a temporary road deck, beneath which excavation further disturbance to traffic is possible.

As with steel sheet piling, possible settlement of the adjacent ground must be considered. Headroom, first for boring, and then for setting the piles, has to be ensured. Obstacles can be dealt with at the boring stage.

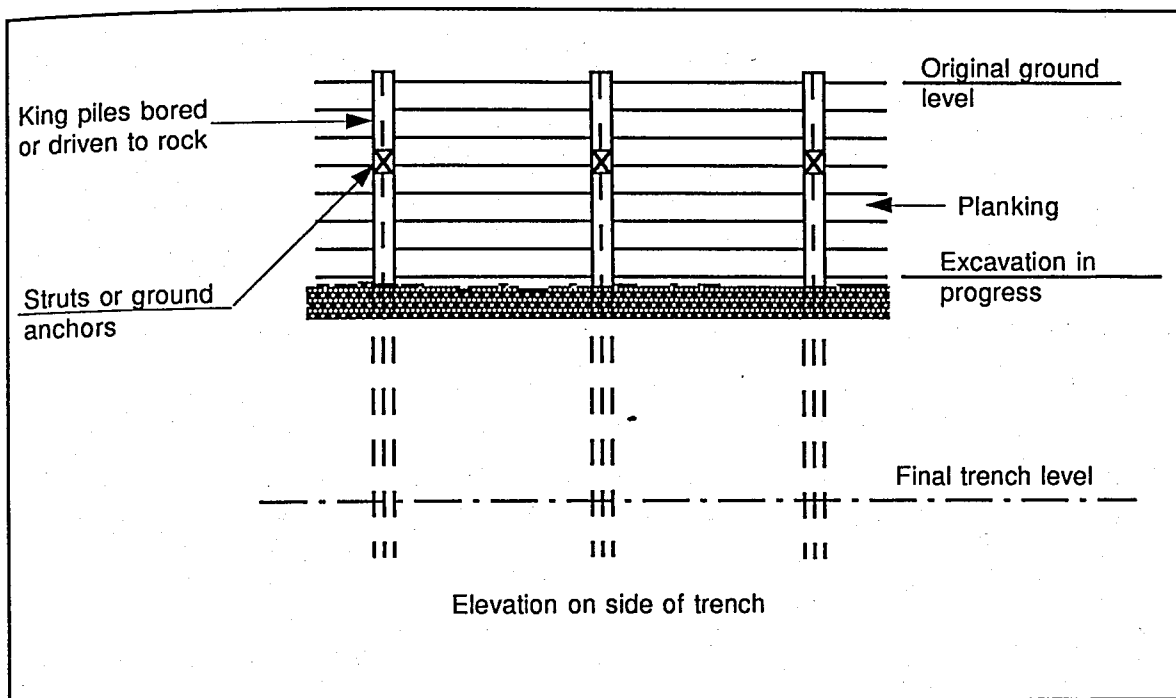

**FIGURE 19.3. KING PILES**

#### **D. Slurry Trench Walls**

Concrete walls cast in slurry filled trenches are a comparatively recent development. A trench is excavated without lateral support except that provided by bentonite or other dense clay slurry filling the trench throughout the process. Within this trench a concrete wall can be cast by tremie, with a reinforcement cage is required. The concrete wall so cast may either be temporary, performing the same function as sheet piling, or may form or be embodied in the permanent structure.

In cut-and-cover tunneling this has the advantage of minimizing surface disruption and obstruction, and of requiring less headroom than sheet piling, although some headgear is necessary. Also, the whole operation is quieter. The permanent wall can be thus constructed, but the finish, if cast against the ground, will be rough and will normally require to be faced up. This wall will be substantially more rigid than sheet piling, although struts or anchors will still be required during excavation of the main trench.

Some surface settlement is inevitable but it can be reduced to a very small magnitude. A hazard with slurry trenching is that if unexpected voids are encountered the slurry may be lost and the trench sides wall collapse. Possible voids in urban areas include unmapped basements, abandoned and fractured pipes and sewers, or old wells.

#### **E. Concrete Bored Piles**

Large diameter bored piles at close centers concreted in situ can be used to form a wall. They may be contiguous or may overlap ('secant' piling). the piles may be taken down to any required foundation level and can be reinforced. In the case of secant piling alternate piles, driven first, may be left unreinforced because they will be sliced down in boring the intermediate piles. With good workmanship substantial watertightness is possible, particularly so with secant piling. The concrete at the head of the piles can be finished to take the roof structure covering the tunnel.

In the Mersey Kingsway Tunnel at the Liverpool approach the twin bored tunnels converge, where the depth to roadway is 18 meters, to a single cut-and-cover tunnel 31.5 to 26 meters wide at road level and about 244 meters long. Contiguous bored piles, 2.4 meters in diameter and keyed into rock, from the walls, and are strutted apart at the top by an arched roof with backfill over. In this instance the principal difficulty of open cut was that cantilevered retaining walls would have been excessively massive, and struts spanning across the top would have been long and heavy and exposed to temperature stresses. Apart from one street crossing the line of the tunnel, the land above was not built over.

## **F. Walls In Heading**

In special cases where access from the surface is particularly difficult, concrete side walls can be built in a heading, either so arranged that the roof slab will be seated on them subsequently, or to underpin a roof slab already in position.

## **20. CASE STUDY NO.7**

### ***LIEFKENSHOEK IMMERSSED TUBE TUNNEL IN BELGIUM***

#### **20.1. Introduction**

The Liefkenshoek Tunnel in Belgium is an immersed tube tunnel at north of Antwerp, crossing the Scheldt Estuary at the border between Belgium and Holland [37]. The tunnel was privately financed and is operated by a special purpose company. The aspect of private finance influenced design as well as excavation of the project and gave interesting aspects related to risk analysis and insurance.

The tunnel was built according to the immersed tube method. In a casting yard in the new harbor, at the left bank eight tunnel units 141 meters long, 31 meters wide and 9 meters high, were built. These units were composed of 6 activities. The units were closed making use of temporary bulkheads. The units don't have steel or bitumen lining. The concrete was cooled to obtain watertightness.

The units were towed through the lock to the river where they were being immersed in a predredged trench. One of the main problems with the marine activities in this project was the extreme high sedimentation in the trench. Nevertheless the foundation could be made by using the new sandflow system.

Due to the fact that the tunnel was built to improve the infrastructure to the heavily industrialized left bank, special precautions had to be made to resist fires and explosions in the tunnel and to improve the safety for the people.

## 20.2. Location

Part of the so-called lower, countries, Belgium and Holland, is formed by the delta of the rivers Rhine, Maas and Scheldt. The most southern part of this delta is formed by the estuary of the Western Scheldt. Some 50 kilometers inland the river Scheldt enters this estuary, when it passes the border between Holland and Belgium. Antwerp, the main harbor of Belgium with a large industrial area is located just south of this border.

The harbor is located almost in the center of the industrial area of which the eastern part is the most developed and the western part is developing at high speed. As one will realize, the infrastructure in and around the harbor and the city are essential for the success of the development. The interference of the seagoing vessels, inland shipping, roads, railroads and pipelines is a main problem for the authorities. A good solution for this is a key factor for the development of the Antwerp harbor.

One of the main aspects of this infrastructure is a road ring around Antwerp. For the most southern crossing of this road ring with the river Scheldt, an immersed tunnel, named Kennedy Tunnel, had been constructed 20 years ago as shown in *Figure 20.1*.

## 20.3. Scheme of the Concession

The Belgium government decided not to finance the tunnel with public money. Like in many other countries the Belgium government wanted to limit its financial obligations. Therefore it was decided to built the tunnel under a so-called concession contract, using private money.

The concessionary was given the right to levy toll from the users of the tunnel in order to be able to pay back the loan. Users are not obliged to use this tunnel. As indicated above there are several alternatives with the old routes, being the small tunnel in the city center for passenger cars only, the saturated Kennedy Tunnel, where no dangerous goods are allowed, and for these dangerous goods a bridge further to the south.

For many of the users these alternatives mean a longer route, increased travel costs and a loss of time. They make an estimate and accept paying toll. In a calculations a factor was included for a psychological effect of levying toll.

The Administration selected four candidates after a prequalification procedure. The candidates received extensive specifications related to this contract.

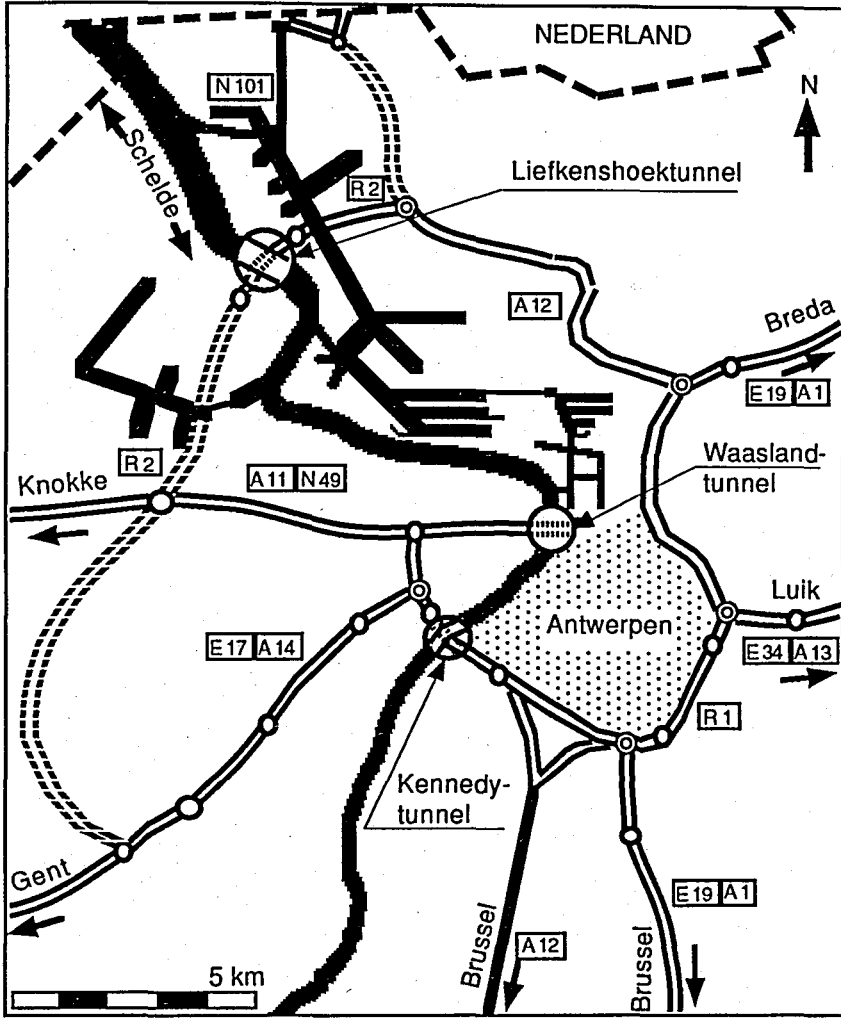

FIGURE 20.1. TUNNELS AROUND ANTWERPEN

The most important conditions were [37]:

- (a) the concessionary designs, constructs, maintains and operates the tunnel at his own expense;
- (b) the government will not intervene financially in the concession, nor will it give guarantees in any shape, manner or form to the concessionary;
- (c) the Road Fund is responsible for the construction of the connecting roads within a period of four years;
- (d) the construction works, to be executed by the concessionary must meet the same technical regulations usual for the designs by the government;
- (e) after ending the concession, the construction together with the accompanying installations will be headed over to the government without any compensation.

The candidate concessionaires were free in their choice of construction methods, construction period, financing scheme, period of operation (with a maximum of 50 years), etc.. One important aspect was the retribution offered by the concessionary to the State as part of the turnover or profit.

The determination of the choice by the government was done with an advanced evaluation model. This model included all relevant macro-economical aspects as well as the social benefits for the society as a whole, such as;

- (a) the capital outlay of the construction;
- (b) the technical value of the design;
- (c) the repercussions of the design on the connecting works at the expense of the Road Fund;
- (d) the professional guarantees;
- (e) the hindrance to third parties during the execution of the works;
- (f) the scientific value of the transport-economical and operation studies made by the candidate-concessionary;
- (g) the financing structure and the accompanying guarantees;

The best solution was offered by a Joint Venture led by De Meyer with two other Belgium partners, Van Laere and Betonac. This Joint Venture formed a separate company acting as the concession holder with an own legal structure. The works were done by the above mentioned Joint Venture. All partners were contractors, each with its own specific discipline.

Their proposal contained an extensive financial scheme including:

- (a) a construction period of maximum 4 years;
- (b) an operating period of maximum 17 years;
- (c) a retribution of the profit after operating and financing costs of 85 per cent;
- (d) good guarantees for a successful termination of the project including;

- (1) professional guarantees;
- (2) sufficient provisions for cost overruns;
- (3) an insurance policy including design construction time-overrun and operation under a so-called wrap-up policy;
- (4) a loan agreement with an international consortium of banks led by the Bank Brussels - Lambert;
- (5) a detailed system for levying toll;
- (6) a detailed and good design with a proper risk analysis.

## 20.4. Construction Methods

As mentioned above, the concession holder was free to choose his own construction method.

When one has to consider a fixed shore-connection, one has the choice between several options. First of all; a bridge or a tunnel. Based upon a comparison made for several projects known, very much in general in flat country a bridge is more expensive than a tunnel in case the bridge must give a free passage to navigation of 20 to 24 meters or more. In this case a minimum of 50 meters was required. Moreover such a bridge should have more disadvantages such as; the impact of weather conditions on the traffic at this high level, problems arising from the connections with the adjacent infrastructure, cost of maintenance and operation, etc. [37].

When a tunnel is selected, there is a choice between an in situ-tunnel, a bored tunnel and an immersed tube tunnel.

It was not allowed to limit the width of the navigation channel in the Scheldt, which even should it be cheaper excluded an in-situ tunnel under an existing water is always much more expensive, than an immersed solution.

The choice between a bored and an immersed tunnel is not always easy to make. Under the Scheldt bored tunnels have been executed. Therefore a study for a bored solution has done. This construction method was rejected, because of following reasons:

- (a) A road tunnel like this one with two tubes for two lanes each, a service tube, good escape and safety precautions, can of course be executed using boring techniques. But it will lead to great diameters and/or a number of tubes.
- (b) The bored tunnel should be considerably deeper than an immersed tunnel. This should lead to higher operating costs and problems with the connections of the surrounding infrastructure.

There is a considerable risk in a bored tunnel related to time and cost. In this case, where we had to live with clearly defined risks to the concessionary, the financiers did not want to support this solution.

With an immersed tube tunnel it will be far easier to control the construction period and for a skilled consultant and contractor it will be easier to define the criteria for immersing techniques and equipment, then is the case with boring techniques. It is more difficult to precisely define the progress rate of a tunnel-boring-machine (TBM) in its environmental and a second TBM will not help either.

When one decides for an immersed tunnel, there is still one major choice left, "Are we going for steel or for concrete?" So far in Europe, only concrete solutions were considered seriously. In many cases brief comparisons were made with the so-called American steel tunnels.

The outcome in many of these was 15 per cent to 20 per cent more expensive than concrete. In the mean time an entirely different solution (European steel solution) is behind developed. It has more resemblance with European concrete tunnels and seems to have a chance. This development was not that far when the construction of the Liefkenshoek Tunnel started.

## 20.5. Main Characteristics of the Project

The total length of the tunnel is 1374 meters as shown in *Figure 20.2*. The constructions at both banks have been built with conventional methods in open excavation. This was kept dry with extensive drainage systems with well points. Partly the water of the drainage system was reinjected to avoid.

Settlement in adjacent very sensitive chemical plants. This system worked as expected.

The constructions at both shores consist of open roadways including the toll platform at the left bank, U-shaped open tunnel sections, pumppits under the full width of the road serving for a wider part of the road and closed sections built in-situ.

The toll platform contains 14 toll booths for manual payment, 7 for each direction, as well as twice two lanes with a tele-payment using a kind of a magnetic card. On this area a building for operation, administration and tunnel-management was erected.

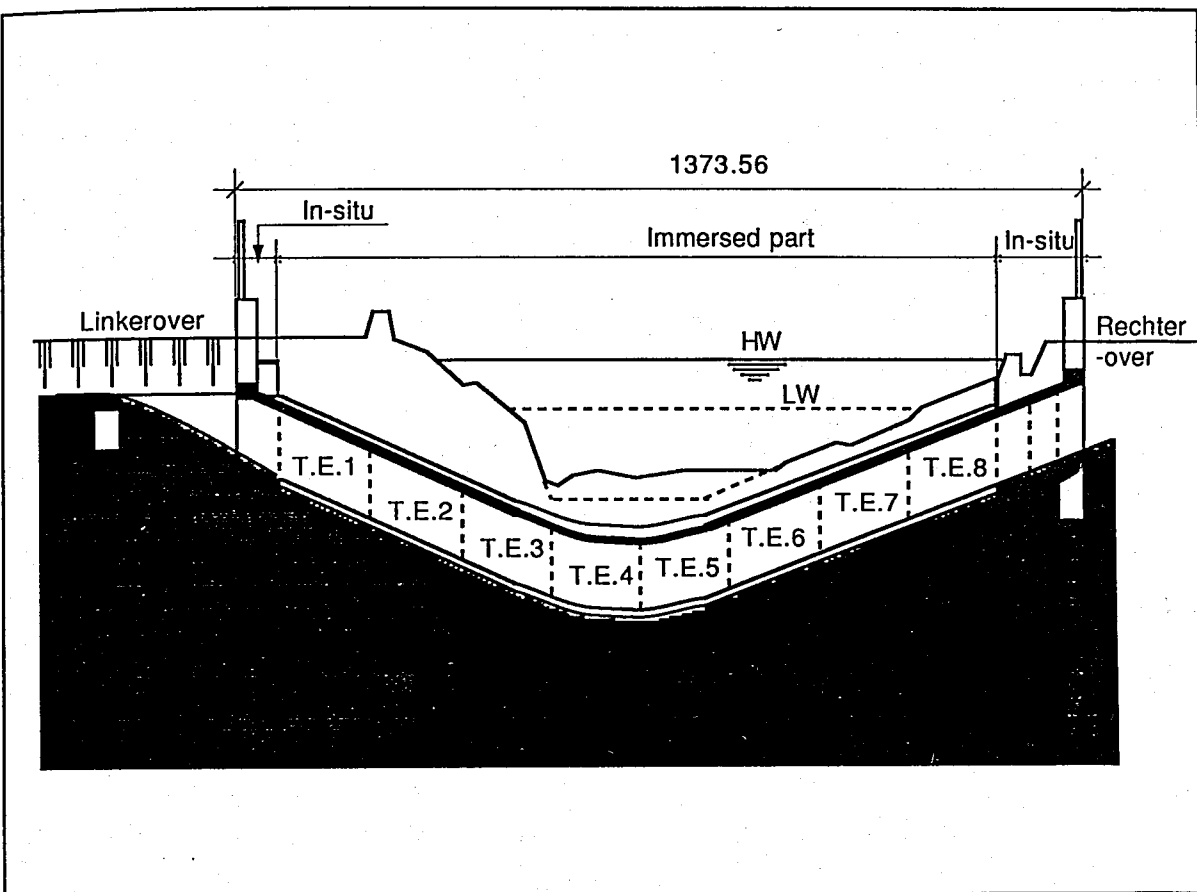

FIGURE 20.2. LONGITUDINAL SECTION (In meters)

## 20.6. The Construction of the Immersed Part of the Concrete Tunnel

The immersed part of this tunnel consists of eight tunnel units, each 141 meters long, 31.5 meters wide and 9,5 meters high as shown in *Figure 20.3*.

The tunnel units were built in the western part of the Antwerp harbor at a place where a future extension of the harbor was foreseen. So the excavation served another purpose as well and that the construction dock as well as the fitting-out quay were in an area without a relatively strong tide and a siltation problem. The only disadvantage was passing the locks. But, this turned out to be a minor problem only.

To avoid suction to the soil when put afloat the tunnel units were built on a foundation of a gravel. The tunnel units were built in sections of about 24 meters, The tunnel units had post tensioning cables of Freyssinet. Thus these sections were held together during transportation and immersing of the tunnel units. The casting of concrete of each section was split into floor, followed by the inner walls. The outer walls and the roof were casted as a whole to limit as much as possible the casting joints.

Like most of the concrete tunnels built over the past 20 years, no watertight coating was included. The watertightness was mainly created by the quality of the concrete and the cooling of the concrete above the casting joints. The concrete mixture contained per cubic meter 80 kg fly-ash with the 270 kg ballast-furnace cement HL30, 1140 kg gravel 4/28, 730 kg sand 0/5, 3 kg of a super plastifier and 130 L of water. The required characteristic pressure resistance was 30 N/mm<sup>2</sup>. After four days there was enough resistance to remove the formwork [37].

The cooling of the concrete was done with a system of pipes just above the casting joint according to an estimate made in advance and subsequently tested in reality. The temperature of the water and the speed of circulation was controlled and regulated.

For the tunnel transport and immersing of the tunnel units, these were equipped with temporary bulkheads, Gina joints, temporary supports and other constructions typical for an immersed tube tunnel and to be dealt with later.

Once all tunnel units were finished, the casting yard was flooded and the units were tested for watertightness. The remaining wall between the dock was dredged away and the finishing out jetty was adapted for the preparation of the tunnel units for immersion.

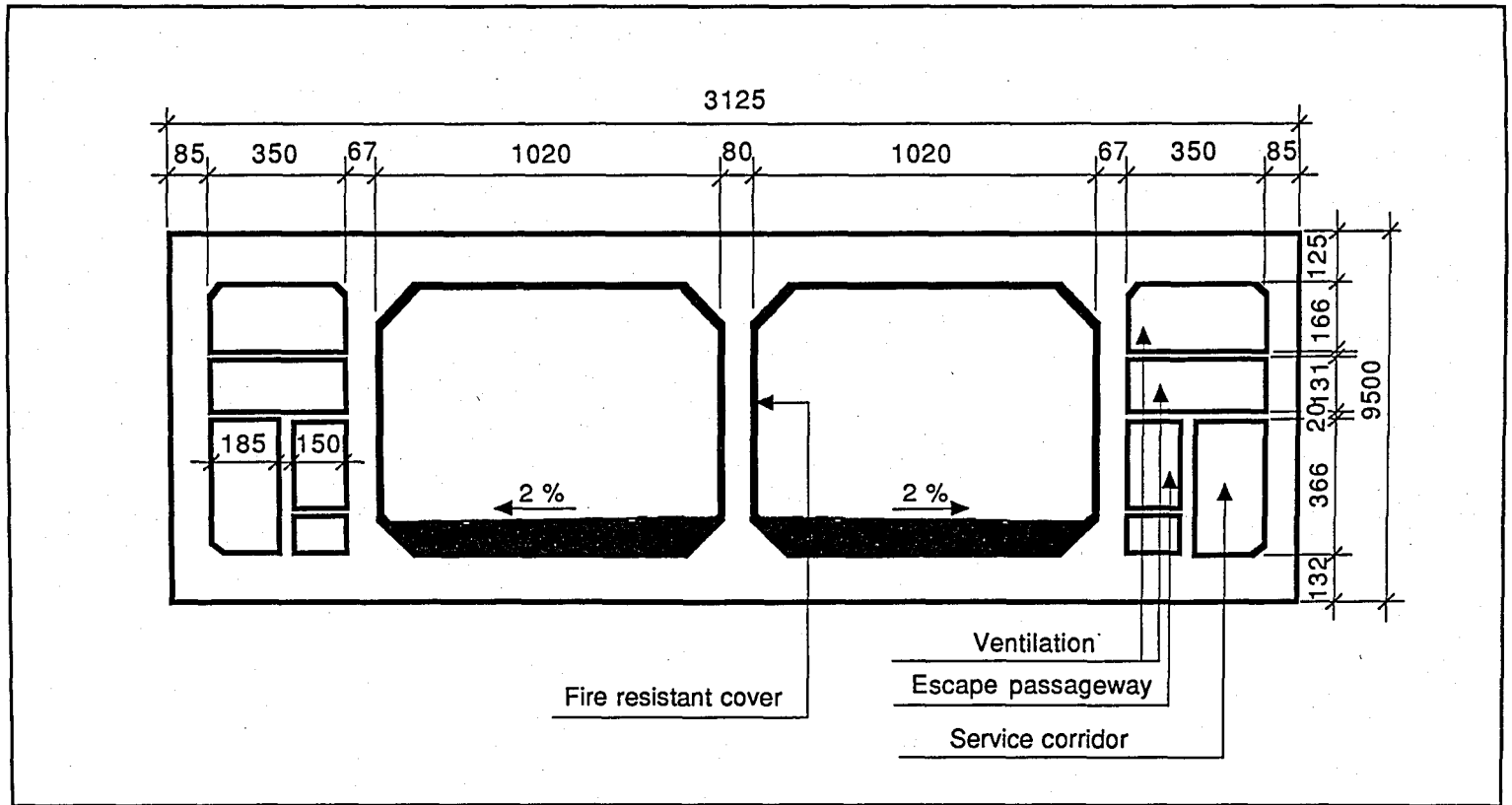

FIGURE 20.3. CROSS SECTION (in mm)

## 20.7. Hydraulic Model Tests

The behavior of the tunnel units can be estimated with a theoretical estimate or tested in a model. Due to the relatively complicated behavior of the river it was decided to make a model scale 1/64 and test the behavior of the units as well as the behavior of the river, its siltation, etc.. For calibration of the model, special measurements were performed.

The tunnel units were tested in many positions and varying conditions in such a way, that almost all possible situations with the related forces on the tunnel units could be predicted. The varying conditions were related to the current velocity, height of the water and the location of the tunnel units with varying x-, y- and z- coordinates. Based upon the results of these tests a feasible immersing procedure with the related equipment was designed.

Additional tests were performed to investigate the behavior of the river related to bottom stability, siltation and bottom transport. From estimates and tests the siltation came out to be a very complex characteristic of this river, at this location, where sweet and silt water met. The floating particles in the water settled down due to flocculation. At the beginning these deposits contained mainly water, but due to the characteristics, these layers were consolidated within several days.

The knowledge of these phenomena was of major importance for the dredging and the way the foundation was brought underneath the tunnel units. Both activities were very much influenced by the outcome of the tests and the estimates. despite the difficult conditions no serious problems occurred.

## 20.8. Dredging

The dredging activities concerned the extension of the navigation zone, the trench for the immersing of the tunnel units, cleaning of the trench from siltation and the backfilling of the trench after the immersing of the tunnel units as shown in *Figure 20.4*.

These activities were very much influenced by the specific conditions of the river, the navigation requirements, the soil conditions and tolerances requested.

The bulk of the dredging was done with cutter section dredgers. The bottom of the trench in relatively hard material was precisely dredged with bucket dredgers, with a tolerance of 30cm downwards. Special care was given to pits in the trench for the concrete tiles of the temporary support of the tunnel units.



**FIGURE 20.4. DREDGING NEAR THE RIVER BANKS**  
*(Courtesy of J. Krokeborg, 1990)*

In order to avoid consolidation of the siltation, the trench was frequently cleaned from siltation with dustpan dredgers. This was also done just before immersing of the tunnel units.

The backfilling of the trench with sand was done with a cutter section dredger and trailer section hopper dredgers. All dredging activities were integrated in the other activities in the harbor and at the river in order to work as economic as possible. In total over 5 million m<sup>3</sup> wet earthmoving was included in the earthmoving activities.

## 20.9. Hydro-Meteo Survey

In order to avoid surprises from weather- or hydraulic conditions and to be able to precisely manage all operations under possible situations a hydro-meteo station was installed on the yard.

At this station all relevant conditions were continuously measured and registered; current velocity and -direction, tide, speed and direction of wind, precipitation, barometric pressure, air temperature, water temperature, relative humidity, etc.. This allowed to predict the conditions that were of influence to the execution of transport and immersing of the tunnel units.

Prior to the immersing and during the immersing weather forecast were given, allowing to anticipate at the conditions, that should be facade. These forecasts were made with up to date systems and direct reception from the satellites Meteosat 111, NOAA and Meteor, a Radio Tele Type - installation- and the reception of the main international weather station Bracknell, Reading and Offenebach on automatised Radio Fascimiles [37].

## 20.10. Transport of the Tunnel Units

As mentioned above. the tunnel units were built in a casting yard in the inner harbor. After the flooding of the dock the units remained on their original foundation due to the fact, that the service corridors were filled with water, thus acting as ballast tanks. When the units were need to be removed to the finishing jetty they were put afloat.

Prior to the emptying of the ballast tanks on the immersing pontoons were put above the units. Winches on these pontoons were connected to the lifting lugs on the roof of the units. When the ballast tanks were emptied these winches pulled the unit against

the bottom of the pontoons. In the mean time the pontoons were connected to fixed points ashore thus avoiding uncontrolled movements of the tunnel units. Subsequently the units were towed to the finishing jetty as shown in *Figure 20.5*. Here all other equipment required for the immersing was installed on or in the unit.

This concerns immersing towers, winches, wires, pulley-blocks and sheaves, communication equipment trimming concrete was placed on top of the tunnel units in order to compensate the differences in the volume of the concrete, its specific weight and the differences in the volume of the concrete, its specific weight and the differences in density of the water in the river as well as in the inner harbor.

Once the circumstances were optimal for the immersing of the unit, it is towed by 4 tugs of almost 4000 hp each through the lock between the inner harbor and the river. Difficult manoeuvres were being performed at slack tide, transport was done with some current in the back and shallow places were passed at high tide.

When the unit arrived at the immersing place it was anchored to anchors hammered in the bottom of the river well in advance. The sequence of the connections with the anchors was depending upon the location of the unit together with the current velocity and direction. These decisions were based upon the outcome of the tests in the hydraulic laboratory. Mooring of the tunnel units is shown in *Figure 20.6*.

## 20.11. The Immersing

The immersing was based upon two different systems. One for the vertical and one for the horizontal movements.

The vertical movements resulted from the filling of the ballast tanks in the tunnel unit with water until the tunnel units had a negative buoyancy of one or two hundred tons. The unit was suspended from the pontoons with winches. Thus these units, each weighing 40.000 tons, could be maneuvered very precisely until they were supported at one side at the previous unit and at the other side on temporary supports consisting of concrete tiles placed at the bottom of the trench. Two steel bars were going through the floor of the tunnel unit on these tiles.

The horizontal positioning was done with winches in the immersing towers. The wires were connected through a system of pulley-blocks and sheaves with anchors ashore on the river. Thus the unit was maneuvered horizontally. Once the unit was very close to the previous unit it was guided with a male and female supporting system with the previous unit, which brought the two units very precisely opposite each other.

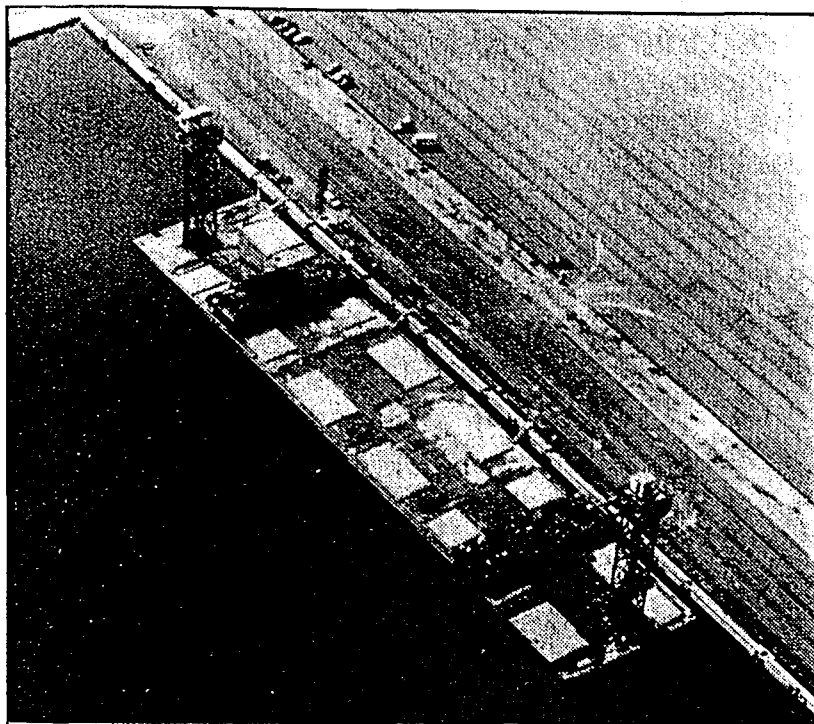

**FIGURE 20.5. THE TUNNEL UNIT AT THE FINISHING JETTY**  
(Courtesy of J. Krokeborg, 1990)

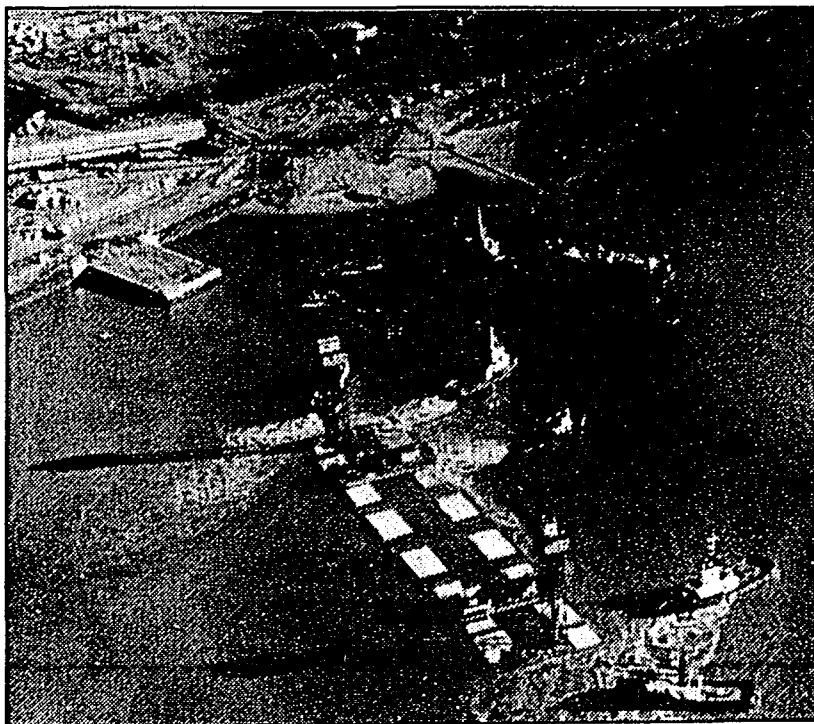

**FIGURE 20.6. MOORING OF THE TUNNEL UNITS**  
(Courtesy of J. Krokeborg, 1990)

## 20.12. Joint

As with most of the European immersed tunnels the joint construction consists of a Gina joint as primary sealing and an Omega joint as secondary sealing. In this case the Gina joint was composed of extruded neoprene rubber. The composition of the Gina joint and the steel frame was done in such a way that the tolerances were reduced to one or two mm. This was of major importance for maintaining a good direction of the tunnel axis after immersing of the tunnel units.

## 20.13. Foundation

Immediately after the immersing, the tunnel unit is resting on the temporary foundation. In this river the space underneath the tunnel units should be filled with sedimentation within a period of one to two weeks. A fast and safe system for installing the definitive foundation was required. Therefore the sandflow system was selected.

The sandflow system consists of the pumping of a sand-water mixture underneath the tunnel unit through holes in the floor, closed with hollow steel balls with a rubber coating as shown in *Figure 20.7*. Through this hole a sand-water mixture was pumped. The sand was settled down on the bottom thus forming a pancake carrying the tunnel unit. When the pancake becomes too big in diameter it will lift the tunnel unit through up-lifting forces. Therefore a whole pattern of holes was installed.

Placing sand was done in at least two subsequent operations. The first to entirely fill the space underneath the tunnel unit to close it for sedimentation. The second to achieve a good compact structure for a good foundation. The whole system, including capacity of ballast tanks, temporary supports, pattern and sequence of sand flowing was based upon assumptions of high sedimentation and varying water conditions as was never faced before. The system worked perfectly well. The entire space underneath a tunnel was filled within 24 hours. The entire foundation was obtained within 70 hours.

## 20.14. Finishing of the Tunnel

As the Liefkenshoek tunnel is also used by transports of dangerous goods, there are extensive safety facilities and suitable equipment available. Each tube has escape passage ways with self-closing fireproof doors, every 50m. Fire resistance is obtained with a 3 cm thick layer on a base of vermiculite to be sprayed against the sealing. Fire-resisting plates are mounted against the walls. Thus there is a fire resistance of four

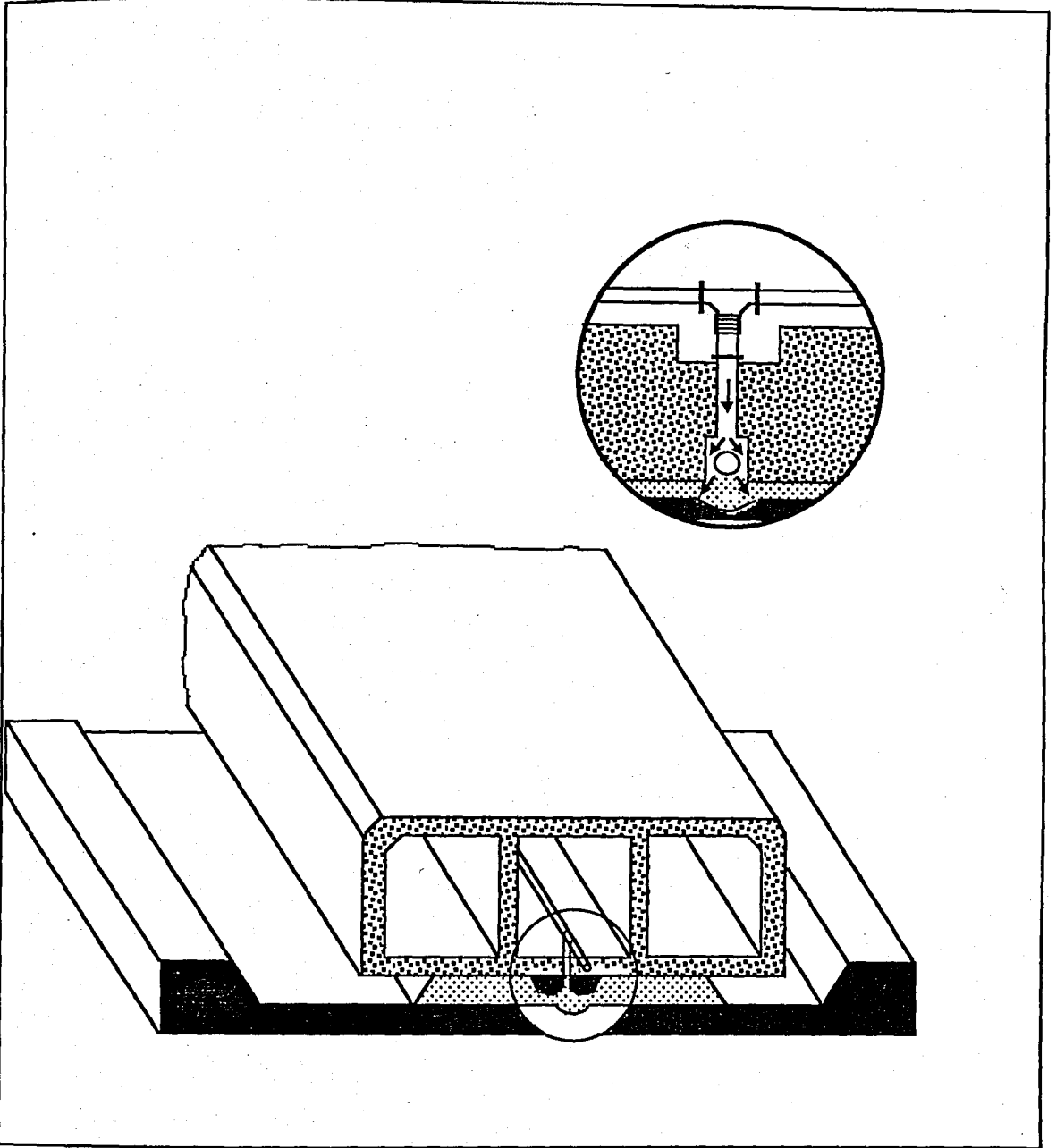

FIGURE 20.7. SANDFLOWING THROUGH THE FLOOR OF THE TUNNEL UNIT

hours at a maximum of 1200 C. An additional reinforcement is used to resist internal pressures of up to 5 Bar for explosions [37].

In the wall between the tubes, safety recesses with all kind of fire-fighting equipment, such as a wall-reel connected with a powder extinguisher, firemouths and a plug-socket, have been spared out. This equipment has been protected against pollution by a fire-proof door.

### **20.15. Service Galleries**

Main cables for lighting ventilation, speedometers, telephone communication, fire-fighting apparatus, etc. are housed beside the escape passageway in the service galleries.

These cables lead to the two technical service buildings situated on the two tunnel-heads and they are connected to high-tension and low-tension fuse-boxes, computer-equipment, no-break apparatus, etc.

### **20.16. Tunnel Ventilation**

The carbon monoxide-level is the parameter that directly defines a tunnel's ventilation system. To high a carbon monoxide-level presents an immediate threat to the tunnel-user's life.

The tolerated carbon monoxide-level has dropped from 400 ppm in the prewar tunnels to the present level of 150 ppm (ppm - parts per million). The design criterium for the Liefkenshoek Tunnel is maximum 150 ppm carbon monoxide-level for slow-moving traffic.

One differentiates between the transverse-, semi-transverse- and longitudinal ventilation.

Longitudinal ventilation by means of booster-fans installed spreaded over the total length of the roadway tubes, is applied in many Belgian tunnels. This system actually requires no special ventilating ducts and is naturally cheaper.

In the tunnels where dangerous freight is permitted, as in Liefkenshoek Tunnel, transverse ventilation is applied. Each tunnel tube is divided into two ventilation sections.

For the ventilation of a section, a blower- and exhauster-fan is positioned at the entrance of the tunnel shaft. Injection and removal of air occurs along two ducts that are built in above the service exit and the escape passageway. Fresh air is blown into the tunnel through grilles.

The layers of these grilles are set up in such a way that air current insures complete ventilation throughout the whole tunnel section. There is an injector-grille every 50 meters.

The contaminated air is sucked off via exhauster-mouths, which are also fitted with grilles. They are located approximately 50 meters apart and accordingly positioned to have an approximate distance of 25 meters between an injector-grille and an exhauster-grille.

Each exhauster-grille can be individually opened or closed by the Control Installation for Inspection, Operation and Supervision.

The complete ventilation system is suitable for processing exhaust-fumes at a temperature of 500 C. during a period of one hour. The ventilation system is, per section automatically operated by carbo monoxide meters.

## **21. CASE STUDY NO.8**

### ***GREAT BELT BORED TUNNEL IN DENMARK***

#### **21.1. Introduction**

The Great Belt Tunnel, connecting the two Danish islands of Zealand and Funen, consists of two single track bored tubes, each 7500 meters long, connected each 250 meters with cross passages [38]. The tunnel alignment crosses glacial tills and tertiary marls down to 75 meters below the surface of the Great Belt. These cross passages thus are connected in a wide variety of ground and ground water conditions.

The cross passage works include extensive soil investigations and ground treatment. The ground treatment methods include vacuum dewatering, microfine cement grouting, spilling, electro-osmosis and ground freezing. The cross passages are excavated by conventional hand methods using both traditional timbering and shotcrete with steel ribs as support. They are lined with hand-build 4.5 meters i.d. SGI segments. Elaborate steel propping frames were used to support the Main Tunnels during excavations.

#### **21.2. Description of the Tunnel**

The railway tunnel project includes the construction of [39]:

- (a) two main tunnel bores;
- (b) cross passages between main tunnels;
- (c) cut-and-cover tunnel sections;
- (d) portal structures;

- (e) ramps;
- (f) part of an artificial island at Sprogø.

### 21.3. Geography

Greatbelt is the main of three channels connecting the Baltic with the North Sea. In this way Greatbelt divides Denmark with the main landmass Jutland and the island Funen to the west and the island of Zealand with the capital Copenhagen to the East as shown in *Figure 21.1 [38], [39]*.

#### A. Project

The construction of the fixed link across Greatbelt was finally decided by the Danish Government in 1987.

From a number of options included in a series of tenders, it was eventually decided to construct the link as [38] :

- (a) a combined rail/road bridge across the Western channel;
- (b) a reclaimed area north of the island of Sprogø, in the center of Greatbelt;
- (c) a suspended bridge carrying the highway across the Eastern Channel;
- (d) a twin bored tunnel to carry train traffic under the Eastern Channel.

The contract for the bored tunnels was awarded late 1988 to an international contracting joint venture - MT Group.

The main drives, two ID 7.7 meters tubes each 7.5 km were to be driven by 4 EPB TBMs. In between the main tunnels, a total of 29 cross passages, 17 meters of length, were to be built.

#### B. Ground conditions

The tunnels and cross passages are constructed in two main ground types namely glacial tills and marls as shown in *Figure 21.2*.

The tills are of quaternary age and consists of gravel, sand and silt with typically between 5-18 percent of clay. The underlying marls of palaeocene age are a weak to moderately weak rock which is a good tunneling material.

The tills were deposited in four glacial cycles which have resulted in two till types, the most recent (Upper Till) forming a very uniform "clay till" with 13 to 18 percent clay

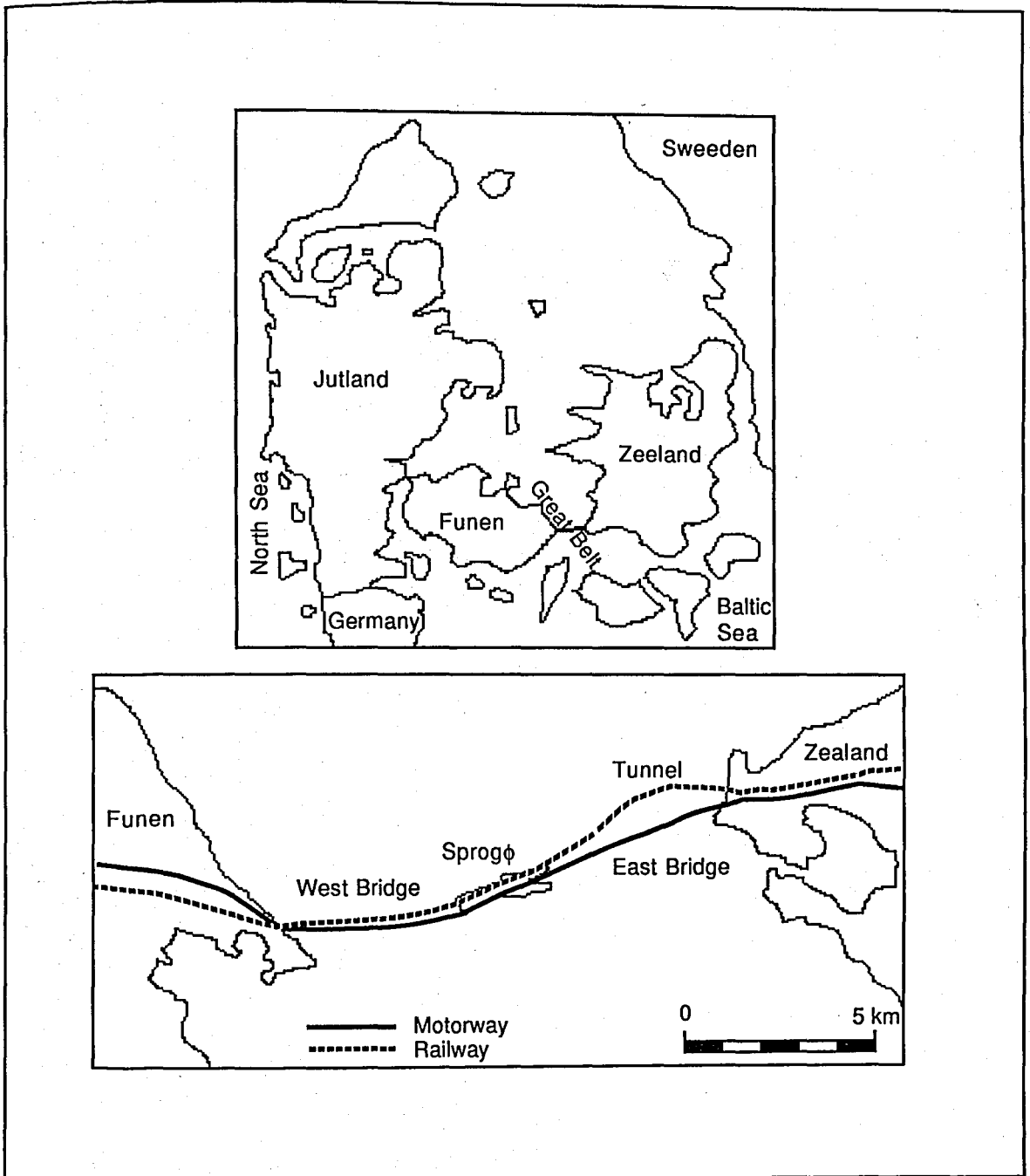

FIGURE 21.1. GREAT BELT RING

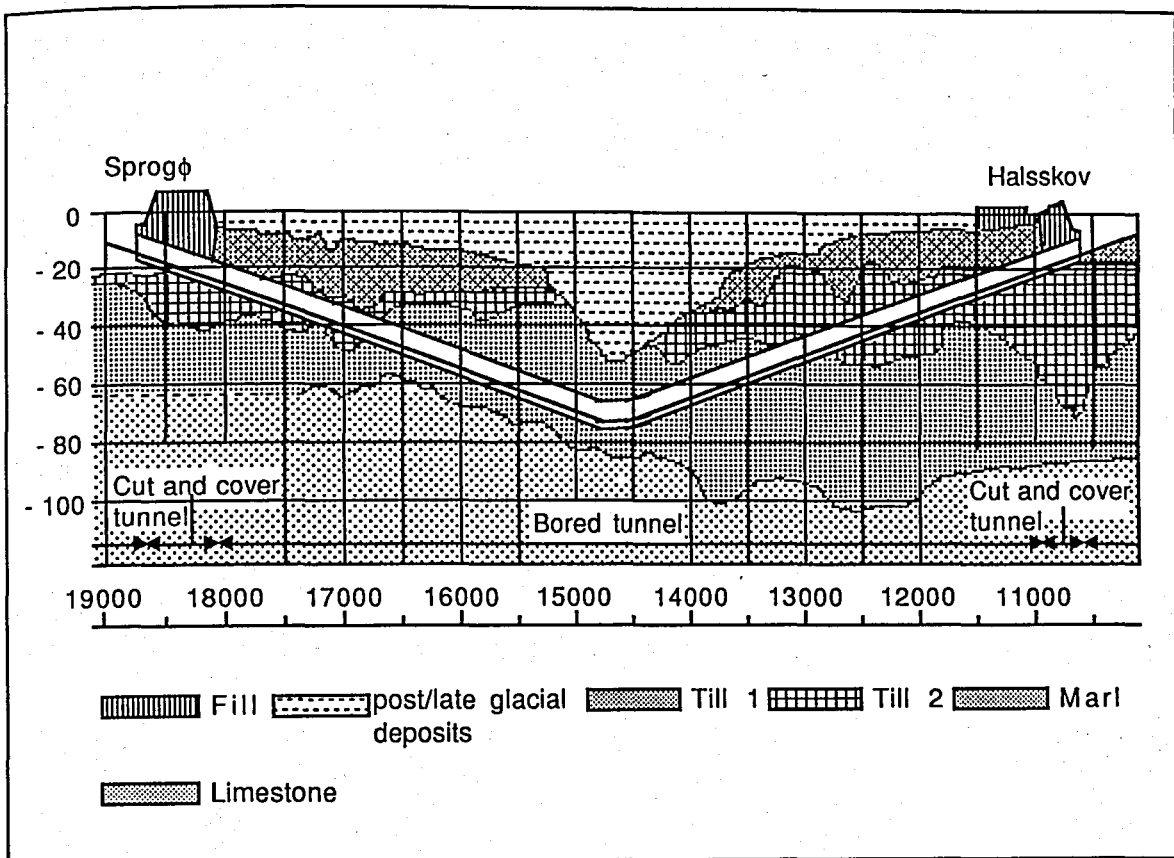

FIGURE 21.2. LONGITUDINAL SECTION (In meters)

content. This till has a typical intact strength of 200 to >300 kPa. The whole upper till unit has a rather low permeability ( $k = 10^{-7}$  m/sec) and forms a protective blanket between 2 and 18 meters thick to much of the subsea tunnel works but is completely absent in the central channel area. Pore pressures before the start of construction were between 1.4 and 2.6 bars.

The underlying tills, collectively known as the lower tills, are very different with less clay and chaotic occurrence of extensive "sand tills" (defined as tills with less than 10 percent clay) and sands.

Permeability of these materials range from  $10^{-7}$  to  $10^{-3}$  m/sec with pre construction pore pressures in the range 2.0 to 4.7 bars.

The heavily over consolidated lower tills are dense and strong in an intact state with a vane strength in excess of 700 kPa but deteriorate very rapidly if the high pore pressures are allowed to dissipate in an uncontrolled manner.

The marls are a gray colored weak rock with an unconfined compressive strength in the range 2 to 14 Mpa with occasional horizontal bands of clay up to 50 mm thick. The marl composition is typically 40-50 percent clay and 50-60 percent calcium carbonate.

The intact marl has a permeability less than  $10^{-7}$  m/sec but some permeable joints result in a horizontal transmissivity of  $3.0 \times 10^{-3}$  m<sup>2</sup>/sec which equates to an average horizontal permeability of  $10^{-4}$  m/sec. The excavations in the marl were expected to encounter pre construction pore pressures in the range 3.0 to 8.1 bars.

## 21.4. Ground Investigation

At the time of tender the contractors were provided with data from 20 offshore boreholes to cover the main tunnel areas which equates to 1 borehole for every 330 meters of offshore tunnel. Additional boreholes were available for the onshore reclaimed and nadir areas [38].

### A. Post tender

The Client continued to undertake investigations post tender and produced a number of overall critical review documents during 1991.

## **B. Subsea Dewatering Wells**

In order to reduce pore water pressures along the tunnel alignment to facilitate TBM maintenance a major subsea dewatering scheme was initiated in 1992. The lowering of pressure in the marls and resulting partial downward drainage from the tills has had a significant beneficial impact on the cross passage construction. In addition the 43 wells and 7 piezometer holes provided valuable additional information on ground and ground water conditions including revealing an unexpected buried valley almost 30 meters deep, intersecting the tunnels and one cross passage.

## **C. Cross Passage Investigations**

Data available from the tunnel boring machines included probe drilling and face inspections as well as many other parameters such as: water make, progress rate, grout takes, steering characteristics and muck quantities.

Actual cross passage investigations were undertaken from purpose built drill trains. between six and 24 holes being drilled depending upon the complexity of the local ground conditions. The patterns consisted of a few cored holes with most holes drilled using the Enpasol monitoring system which continuously monitors: Thrust, Torque, Speed of advance, Water injection pressure, Water inflow rate, Water overflow rate.

By keeping thrust, water inflow and pressure sensibly constant it is possible to correlate the other parameters with differing ground conditions.

The interpretation was developed to a high level, initially on the TBM probing but particularly after the excavation of the first cross passage when the accuracy of the system was appreciated. It was possible with the Enpasol to make the very important distinction between clay till, sand till and sand to produce an accurate prediction of ground conditions for ground treatment design.

Investigation holes were equipped with either piezometers, well points or TAMs (tube a manchette for grouting). One of the primary aims of the instrumentation was to establish the vertical pore water pressure profile which was usually complex and did not follow a simple hydrostatic distribution.

Detailed observation and logging took place during excavation of the cross passages, the experience being used for subsequent cross passages. The results consistently showed that the initial interpretation and consequent level of ground treatment was correct.

## 21.5. Ground Treatment

### A. Till Areas

The intact tills are sufficiently consolidated to provide a stable excavation face but only when pore pressures are controlled. The prime object of the ground treatment in the tills was therefore to reduce to pore pressure. A design criterion of 0.5 meters was suggested by MT Group of pressure of one percent of the initial pressure for the deeper passages. This target was achieved in all but one cross passage and resulted in stable face conditions [38].

The ground treatment was executed from both tunnels and typically consisted of: Contact Grouting - 106 holes, Spile Bars - 15 x 6.0 meters long, Well points - 60 number with slotted length, 4 - 10 meters.

Because of the low permeability ground it was essential that the well points were particularly efficient and this requirement led to the development of a unique system. The problem of placing a sand filter outside a well screen in an upward pointing hole was overcome by injecting a sand polymer suspension through the drill string as it was being withdrawn. The well point is then placed into the hole which is equipped with preventers and valves.

The well points formed an array completely surrounding the cross passage as shown in *Figure 21.3*.

In CP 26 the anticipated slow drainage due to high clay content was accelerated by the use of electro-osmosis via the steel spile bars and additional steel points. The limited trails indicated that drainage was accelerated.

### B. Meltwater and Disturbed Areas

In most areas meltwater sands were present in or around the cross passages. Where these materials were not disturbed by the TBMs they provided beneficial to the dewatering, as described above, being able to drain water more efficiently via the permeable layers.

However it was extremely difficult to mine the sands, sand tills and occasional gravels which had up to 4 bars of pore pressure without causing some disturbance.

Where highly permeable or disturbed ground was found varying combinations of grouting and freezing were used with the dewatering.

One cross passage, CP27, has so far been excavated using brine freezing with Calcium chloride as a refrigerant.

Grouting techniques have been used on several cross passages. Permeation grouting using micro fine cement via TAMs has been successfully used in medium sands and coarser granular materials. Finer materials, in a disturbed state, have been injected using claquage techniques with both cement-bentonite and micro fine cement grouts.

An total of ten till cross passages had been constructed by the end of 1993 using these techniques. The remaining three till/interface cross passages are planned to be constructed during 1994 and 1995.

### **C. Marl Cross Passages**

The marl excavations are basically stable when limited openings are used and shotcrete is applied to any faces left to stand. The ground treatment was therefore directed to controlling water inflows.

Due to the effects of the subsea dewatering water scheme, pressures in the top of the marl were much reduced. This enabled relatively dried conditions to be achieved with a limited number of well points. Six cross passages, CP's 20 - 26 were constructed in this way in 1993 using between 24 and 30 well points for each one.

In the deeper cross passages pressures between 5 and 7 bars outside the influence of the fracture zones led to the adoption of grouting techniques in combination with dewatering. Because previous excavations had typically shown flow from relatively tight fissures a range of grouts were considered starting with micro fine cement for the first pass with a facility to use ordinary cement or rigidified cement if conditions indicated serious fissuring. CP 19 and CP18 were completed in January 1994 and were substantially dry, confirming the efficiency of the microfine cement grouting.

Where flows were less than 20 L/minute holes were injected in a single pass but higher flows were treated via TAMs without sleeve grout filled polypropylene bags. In this way holes with flows in excess of 1000 L/minute were successfully treated with macro fine cement. The treatment was designed to form an annular collar around the cross passage and not specifically treat the face. An array of well points was installed outside the grout treatment.

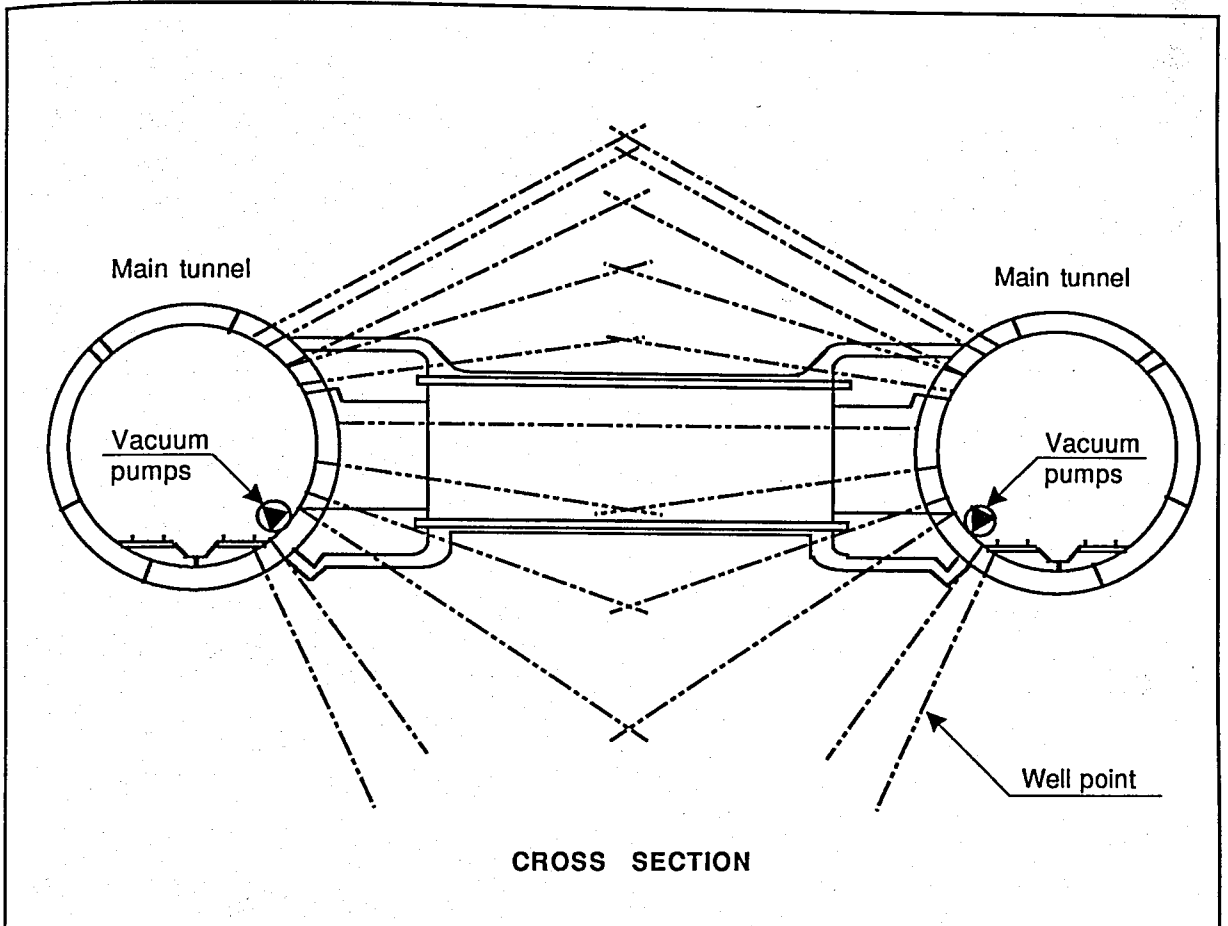

FIGURE 21.3. WELLPOINT ARRAY AT CROSS PASSAGE

## 21.6. Monitoring

An exhaustive monitoring campaign was performed during ground treatment and excavation. The monitoring system was designed to perform three main functions [38]:

- (a) To ensure the integrity of the Main Tunnel segmental lining during ground treatment and cross passage construction. Lining deformations were limited in accordance with the designers specifications and criteria developed by the contractors monitoring team.
- (b) To verify the success of the ground treatment program, especially regarding water pressures, before starting excavation. Sign-off criteria were defined and had to be fulfilled before excavation was allowed to commence.
- (c) To monitor the primary support and the behavior of the surrounding ground during excavation.

### A. Water Pressure

The water pressures in the surroundings ground were measured by piezometers.

### B. Main Tunnel Lining Deformations

Since a segmental lining is highly susceptible to deviations from the ideal circular shape, special care had to be taken to maintain the Main Tunnel lining within the specified tolerances.

The deformations of the lining were monitored using a three dimensional survey technique rather than the more conventional tape extensometers or piano wires. Reflective targets were placed in up to 40 locations within the eight rings closet to the CP. They were surveyed using a precision theodolite with coaxial distance measuring capabilities and referenced to a number of fixed points placed about 50 meters up and down the tunnel, outside the influence of the excavation.

This method yields absolute movements of each point in all three dimensions. Rigid body movements of the lining can thus be separated from the more critical squatting components. The accuracy of the readings was in the order of 0.5 mm. A trammel survey was performed prior to zero reading of the system, allowing a correlation between incremental diameter changes and actual tunnel diameter.

This manhood of controlling lining deformation was used both during excavation and during critical ground treatment operations.

The deformations of the lining could be very accurately followed with this system. The tunnel diameter changes were in the order of 5 to 10 mm in the tills (with the exception of 20 mm at CP26) and 2 to 3 mm in the competent marls. All movements leveled off shortly after construction had been completed in the immediate neighborhood of a tunnel. Ground treatment like grouting and freezing had a noticeable effect in reducing the deformations.

### **C. Other Monitoring**

The stresses in the propping frame were monitored with vibrating wire gauges connected to a data logger and with handheld mechanical strain meters. The latter method was also used to monitor the stress changes in the concrete segments in locations where cracking was deemed possible.

In cases where cracks had formed in the concrete segments, the crack widths were measured regularly and glass plates placed as tell-tales. In cases where freezing was used to support the ground, temperature couples were placed in boreholes and monitored frequently to follow the development of the freeze.

## **21.7. Excavation and Support**

Excavation methodology had to adapt to the different ground conditions. Different methods were used in the glacial tills (14 CPs) and in the marls (15 CPs). The excavation was furthermore influenced by the type of opening set. In the tills and in some of the shallower marl CPs, concrete opening sets were placed, in the lower marl CPs, SGI opening sets were used [38].

Due to the difficult ground conditions encountered, the decision on excavation and support methodology had to be based on the widest possible agreement between the viewpoints of all concerned parties. The final method is thus a compromise that had the support of both client and contractor and their respective advisers.

### **A. Propping, Safety Door and Opening**

In order to prevent the main tunnel lining from distortion during the construction of the cross passages, a temporary steel structure was installed to prop the tunnel. The design philosophy in the propping structure was to transfer loads to areas in the ground, where adequate passive resistance could be established to outbalance the asymmetric lining loading, developed during the excavation of the cross passage.

To ensure that even an extensive ground loss and possible subsequent inundation of a cross Passage under construction would not have fatal impact on the tunnel crews, steel doors were integrated in the propping structure.

These doors could by means of an air-driven hoist system be lowered within few minutes, should an emergency situation occur. The doors were further used as a safety measure, if a cross passage under construction was left unattended.

## **B. Excavation in the Tills**

The designer had presented two designs for the cross passages:

- (a) one based on NATM principles;
- (b) and one based on SGI segments as a final lining.

When construction of the CPs approached, the final choice was made, centered on the use of SGI lining, but contained a redesign of one primary lining support to the mass concrete junction structure between the cross passage and the Main Tunnel lining.

Excavation for these structures incorporated the use of temporary concrete foundation walls poured in a lower side drifts and multiple stage shotcrete techniques.

The proposal to use SGI segmental lifting was prompted by two reasons:

- (a) The advantage of having the full support action of the ring available immediately after erection.
- (b) The possibility of avoiding the problems of handling large shutters in the restricted working environment of the tunnels.

In addition, no waterproofing membranes had to be placed. It was felt that these advantages outweighed the disadvantages of slower advance rates and stricter assembly tolerances for the SGI segments.

The excavation method best fitted to these lining concept and the restricted work conditions was hand excavation. A specialist firm, ANGLEGLOBE LTD., employing mainly Irish miners was subcontracted to carry out the excavation work. Temporary support initially consisted mainly of traditional timbering, but was augmented with shotcrete as experience and confidence increased.

A 1.8 meters id. Pilot Tunnel was driven first between the two tunnel. This was used to verify the ground conditions and the success of the ground treatment. A break-out was performed from the pilot tunnel about 5 meters distance from the Main Tunnel and the first 4.5 meters id. SGI rings were built. From there, excavation proceeded in the direction of the start - up side. Small side drifts were advanced at the bottom of the collar structure

and the filler walls cast inside. Once support of the Main Tunnel was thus assured, the full collar cross section was excavated and supported with shotcrete and steel arches.

Excavation direction was then reversed and the cross passage advanced towards the finishing side. Excavation ended with the construction of the collar on the finishing side as shown in *Figure 21.4*.

### **C. Excavation in the Marls**

The marls proved to be a far more stable tunneling material than the tills. The basic excavation methodology was retained, but some changes were made.

No pilot tunnel was built, collar construction was performed as the first step. Since the marl was sufficiently hard to support the Main Tunnel lining, no filler walls were required. Instead, collar construction followed a NATM routine of top heading, bench and invert. Lattice girders were used instead of steel arches.

The main drive was practically identical to the method applied in the tills, except for shotcrete being the main means of temporary support. Occasionally, friction rock bolts were used to stabilize local wedges.

The marls proved soft enough to be excavated with hand-held air powered tools. However, a small road header was held ready in case harder ground would have been encountered.

### **D. Geotechnical Supervision**

Excavation of the cross passage was closely followed by the contractors geotechnical team. In the tills, vane tests were performed in addition to a regular face mapping and tight control of the water regime.

In the marls, a slightly modified Q-system was applied to classify rock quality and decide the required amount of support.

## **21.8. Permanent Works**

Upon completion of the ring building and collar primary lining, the cross passages were taken over by civil work gangs, for construction of the permanent works collars, floors and plinths as shown in *Figure 21.5*.

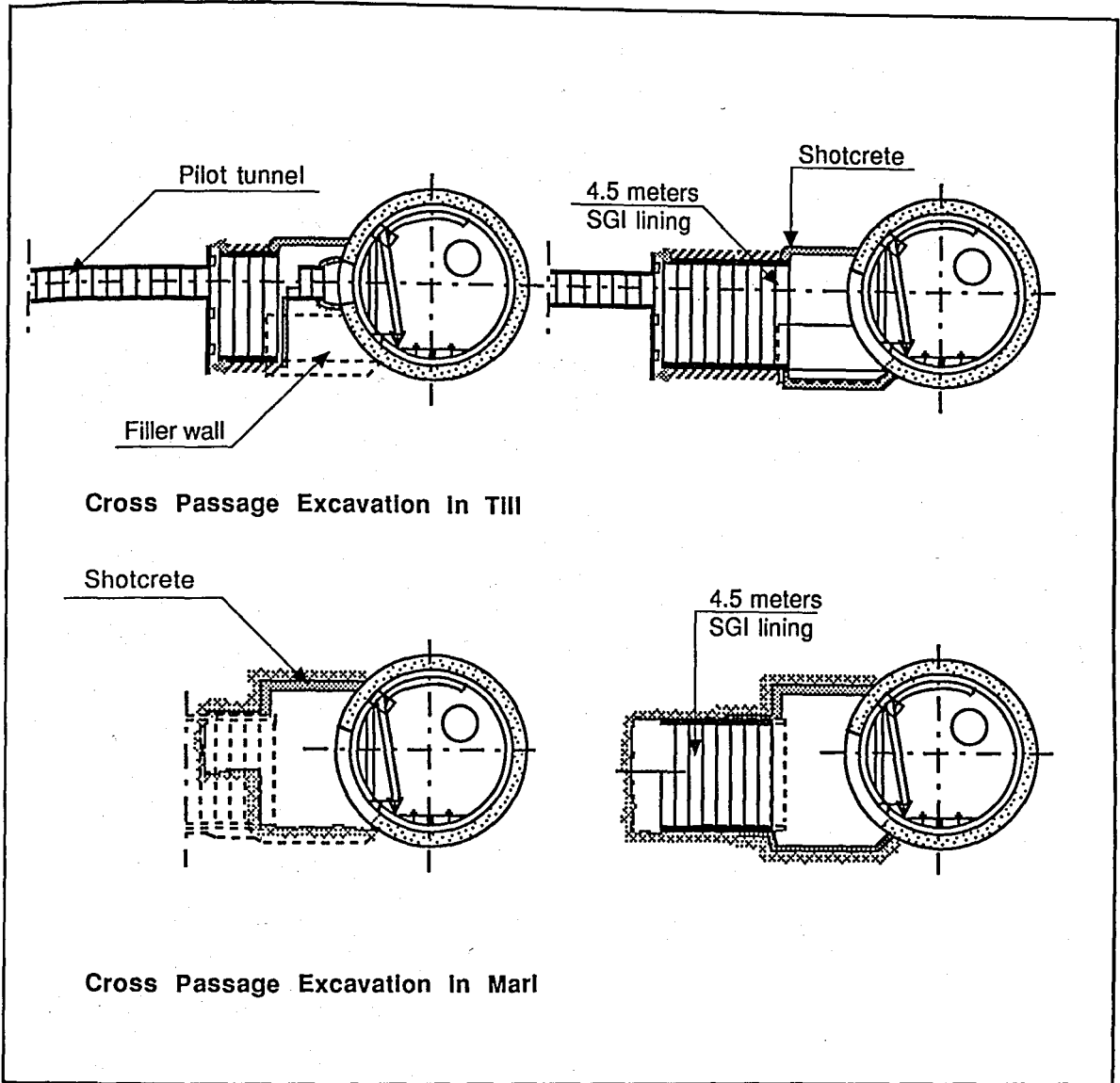

FIGURE 21.4. CROSS PASSAGE EXCAVATION

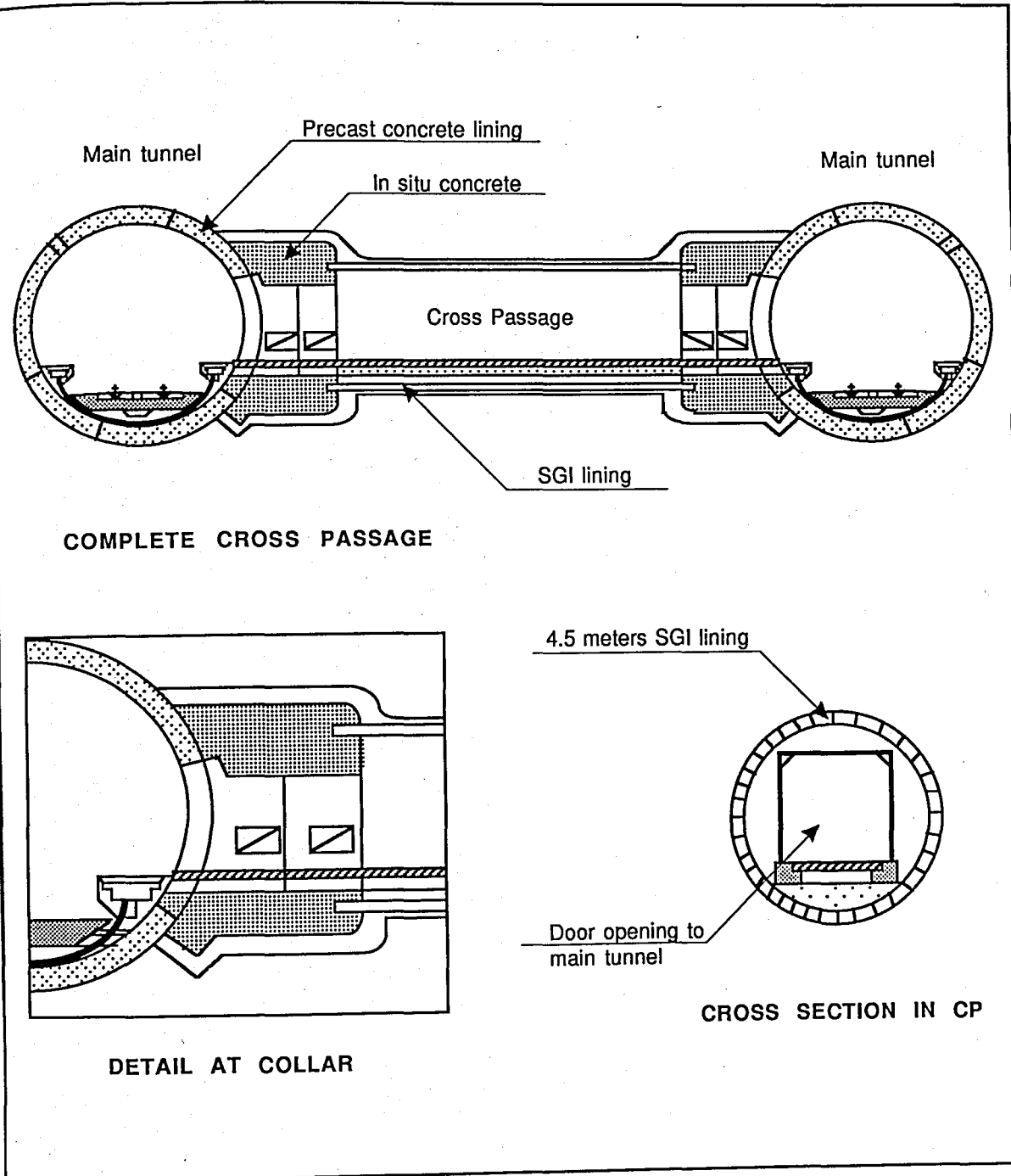

FIGURE 21.5. CROSS PASSAGE COMPLETED

Upon completion of the finishing works, the cross passages are being handed over to the Client for giving access to the subsequent Contractor to commence installation of equipment forming part of the permanent installations.

## 21.9. Cut-and-Cover Tunnel

Within the cut-and-cover tunnel section, the railway tracks converge from 15 meters centerline spacing at the bored tunnel to 9 meters spacing at the portal as shown in *Figure 21.6 [39]*.

The tunnel structures has been designed as two in-situ reinforced concrete boxes protected by external bentonite waterproofing membranes. An octagonal cross-section was chosen which, while it increases slightly the amount of construction work required, uses less material and substantially reduces the bending moments compared with the normal rectangular section. The tunnels has been designed as monolithic structures between the bored tunnel and the portal with no movement joints. A main factor during the construction was the specified requirement for strict control of temperature gradients during concrete curing to limit early-age cracking.

The general cross section at the portal is shown in *Figure 21.7*, changing from twin boxes to a single unit with a central wall.

Special joints have been designed for transition between the cut and cover tunnel sections and adjacent bored tunnel and portal structural elements. These were free to move during construction. After backfilling and release of ground water pumping, the joints were concreted so that eventually cut-and-cover tunnels act monolithically with the bored tunnels and portal structures.

## 21.10. Portal Structures

At each end of the tunnel, a portal structure of reinforced concrete were constructed providing a portal building, *Figure 21.7*, and pumping station. The building contain high voltage power plants for the tunnel systems, and control rooms for the surveillance of the railway services and the tunnel installations [39].

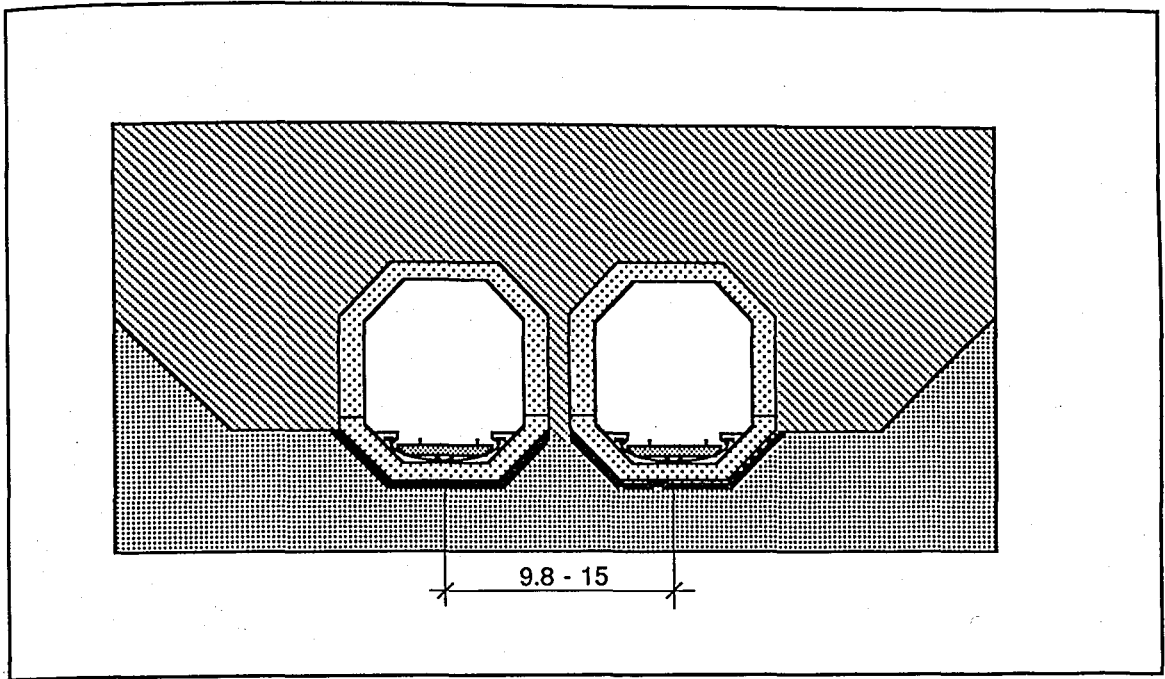

FIGURE 21.6. CUT AND COVER TUNNELS (In meters)

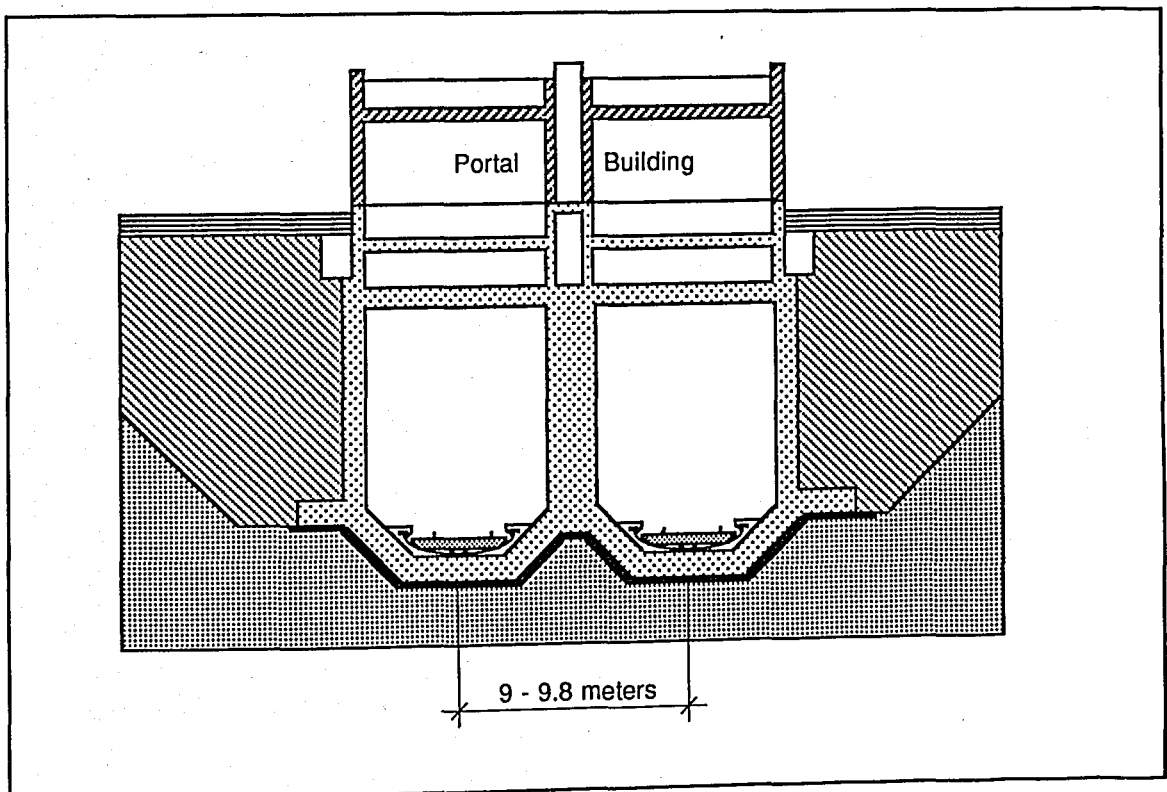

FIGURE 21.7. TUNNELS AT PORTAL (In meters)

## 21.11. The Ramps

The ramp on the Zealand side starts at a level of +1.0 meters and leads down to the portal structure at level -15 meters. The ramp is excavated in the dry behind the coast line and is to be protected against flooding by surrounding dykes [39].

On the Sprogø side, the ramp connects the embankment for the bridge across the Western Channel at level +5.5 meters with the portal structure at level -15 meters. The ramp is excavated in an artificial island and is protected against flooding from the sea by surrounding dykes and coast protection works.

The ground water table will be maintained below the ramps structures by a system of pressure relief wells and subsoil drains. Surface and ground water from the ramps is led to a pumping station adjacent to each portal from where it is pumped in to the Great Belt.

## 22. FERRIES

### 22.1. Introduction

Communication to a large majority of the island scattered along the coast and across fjords is only possible by boat, as the population density does not warrant bridges or tunnels, or the distances simply are too long to build fixed connections, both from a technical and an economical point of view.

The ferry system is considered a part of the road system. Having accepted that the ferry is a floating road link, the capacity in number and individual size must balance the road capacity both with regard to weights as well as to size of vehicles to be carried in the road system and its throughout going capacity [41], [42],[43].

### 22.2. Different Types of Ferries

#### A. Standardization of Ferries

At the end of the 60's the different inland ferry companies started a process for standardization of car ferries for fjord crossings [41].

Two different types of ferries were developed - fjord ferries and double symmetrical shuttle ferries. The fjord ferries are looking more like conventional ship with one (or two) propeller(s) in the stern and one thruster in the bow for sideway maneuver.

The possibilities for passengers and crew were both placed under and above the main deck (car deck.)

The double symmetrical shuttle ferries, also called "pendulum ferries" are symmetrical and equally equipped with propellers and steering facilities in both ends. They are also equipped with double bridge facilities in the wheelhouse.

All the facilities for passengers and crew were placed under the main deck (car deck.) The standard ferries were built to carry from 30 to 150 PCU.

The main advantages from building standardized ferries are the flexible use of ferries in different connections, low training costs and economics of scale concerning building and maintenance.

The standardized ferries, with some modifications, were built more than twenty years. A new generation of standardized ferries was developed around 1990. This new generation consists of two different types of ferries; SSC-ferries and SLC-ferries.

SSC-ferries - Standardized ferries for Short Connections are equipped with watertight bulkheads and double bottoms. All facilities for passengers and crew are placed above the main (car) deck, and evacuation will take place from the main deck. The passenger facilities are rather plain.

The ferry is simple to embark and disembark. The heavy vehicles are embarking in the middle of the main deck while the passenger cars embark on top of the deckhouse.

The main advantages of the SSC-ferries (and the SLC-ferries) are the increased stability of the ferries - maximum heeling will be 7 degrees (theoretically) in case of a collision, easy embarkment and disembarkment, easy evacuation and increased safety for passengers and crew since all facilities are placed above main deck.

The SLC-ferries (Standardized ferries for Long Connections) are more well-equipped than the SSC-ferries as regards facilities for passengers. They are equipped with lifts, restaurants etc. and some of them are closed to be certificated for open sea operations.

## **B. Standard Ferry Designs**

During the last 15 years only standard ferries have been built in Europe. This standardization of ferries in sizes ranging from 20-140 PBE was a significant lift of standards. It also created a flexibility within the system that made it possible to operate the ferries with a much larger flexibility than hitherto. This due to the fact that any standard ferry could on short notice be put into any designated ferry connection without trouble, as the ferry would fit the terminal [42].

After 15 years, roughly one third of the ferry fleet has been standardized and the average age is slightly above 16 years. Even with this rationalization of design and thus improved flexibility, about half the fleet is still less than 30 PBE capacity with too small deadweight as referred above. This clearly shows that the amount of ferries being built does not satisfy market demand.

*Table 22.1* shows the composition of the ferry fleet and the changes throughout the last five years.

As stated, it is evident that this development by no means has been able to match the general traffic growth. This is particularly evident as the reduction of the number of smaller units is far less than required to ensure satisfactory capacity and thus, a smooth traffic flow.

*Figure 22.1* shows a very interesting diagram of the loading capacity and the weight per car unit carried. These two diagrams underline the vital importance of increasing the number of new buildings furnished to the fleet in the coming years.

### **C. High Speed Light Craft**

High Speed Light Craft are in operation around the world in short sea shipping. The majority of present high speed light craft are passenger only craft being operated in combination with traditional ferries or fixed strait crossings [43].

Recent development open for both car and truck capacities. The high speed light craft may thus represent an alternative to conventional ferries and also to fixed strait crossing alternatives.

## **22.3. Conclusions**

The development of new high speed light craft during the last few years in combination with development of the basic technology and the governing regulations, results in designs that should be taken into consideration when new strait crossing projects are being evaluated. High speed ferries adds to the potential of traditional ferry solutions and may represent an interesting alternative to fixed strait crossings or a supplement to a fixed crossing as part of a total transport system.

TABLE 22.1. COMPOSITION OF FERRY FLEET

| Size of ferry (PBE) | 1983 | 1988 | Change |    |
|---------------------|------|------|--------|----|
|                     |      |      | +      | -  |
| 10 < 20             | 69   | 64   |        | 5  |
| 20 < 30             | 63   | 50   |        | 13 |
| 30 < 40             | 36   | 42   | 6      |    |
| 40 < 50             | 34   | 32   |        | 2  |
| 50 < 60             |      | 5    |        |    |
| 60 < 70             |      | 5    |        |    |
| 70 < 80             |      | 3    |        |    |
| 80 < 90             |      | 10   |        |    |
| 90 < 100            |      | 1    | 13     |    |
| 100 < 110           |      | 1    |        |    |
| 110 < 120           |      | 1    |        |    |
| 120 < 130           |      | -    |        |    |
| 130 < 140           |      | 5    |        |    |
| > 140               |      | 4    |        |    |
|                     |      |      | 19     | 20 |

Standard double ender ferries 30 <140 PBE  
 Older double ender ferries <50 PBE  
 Fjord ferries <80 PBE

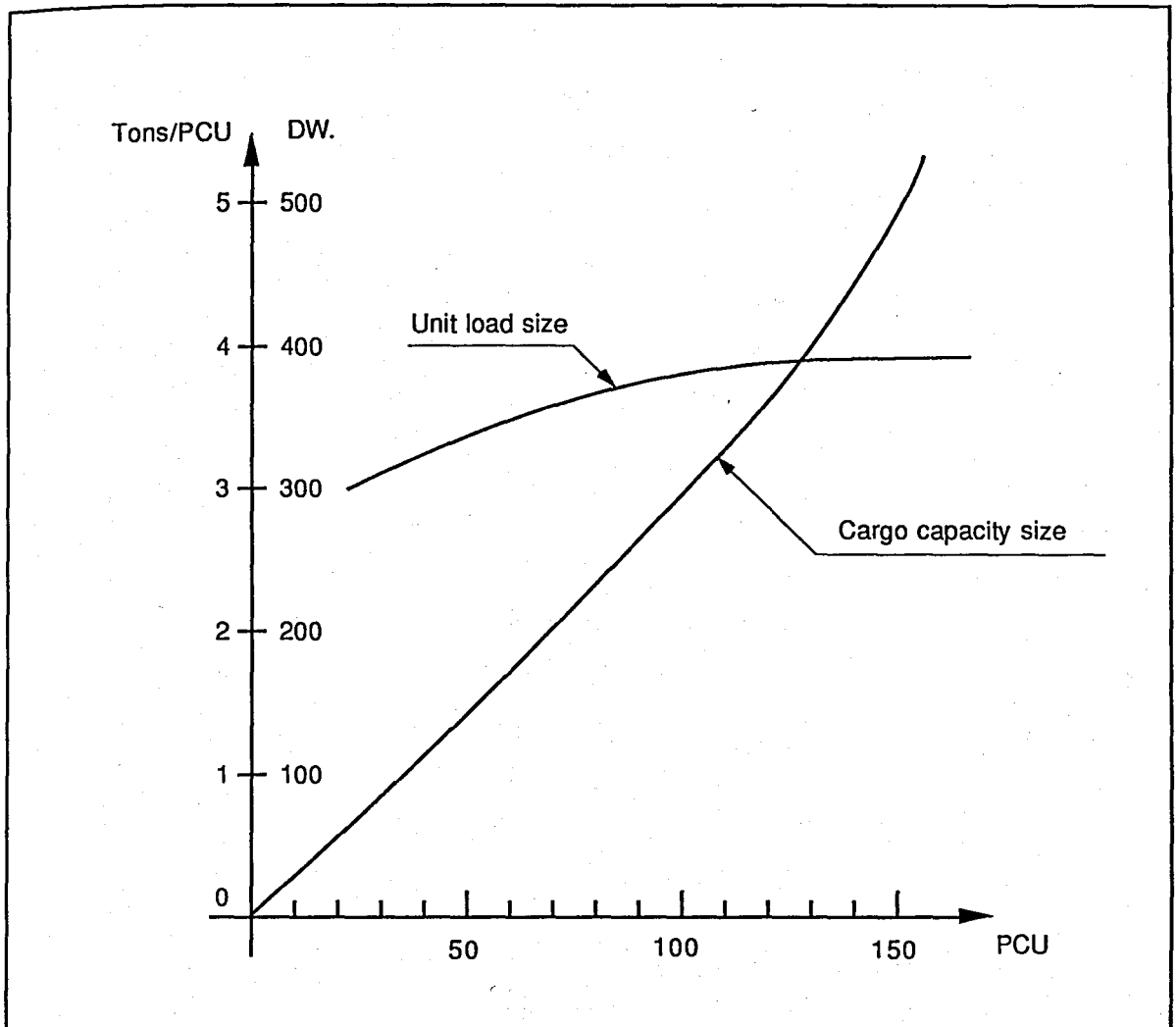

FIGURE 22.1. CARGO CAPACITY AND UNIT LOAD

## **23. CASE STUDY NO.9**

### ***ESKIHISAR-TOPÇULAR FERRY LINK***

#### **23.1. General Remarks**

Eskihisar-Topçular link which connects the Izmit Bay has a 4.4 naut mile. The link was opened in May-1989. Eskihisar-Topçular link has replaced Kartal-Yalova link. These two links operated at the same time to the end of September-1989. After that time Eskihisar-Topçular link has started to operate with full capacity.

The ferries used are much like SSC-ferries. All facilities for passengers and crew are placed above the main deck and facilities are plain. There are 10 ferries operating on the link. Six of them are big (85x23 meters) with 100 auto capacity and the other four are smaller (60x20 meters) with 70 auto capacity. Under normal conditions it takes 40 minutes for a ferry to go from one side to other including embark and disembark.

The number of vehicles and passengers carried between 1990-1993 are given in the *Figure 23.1 to Figure 23.7*. As can be seen in the figures the number of passengers carried decreased but the number of vehicles increased. The data are taken from Turkish Maritime Organization [44].

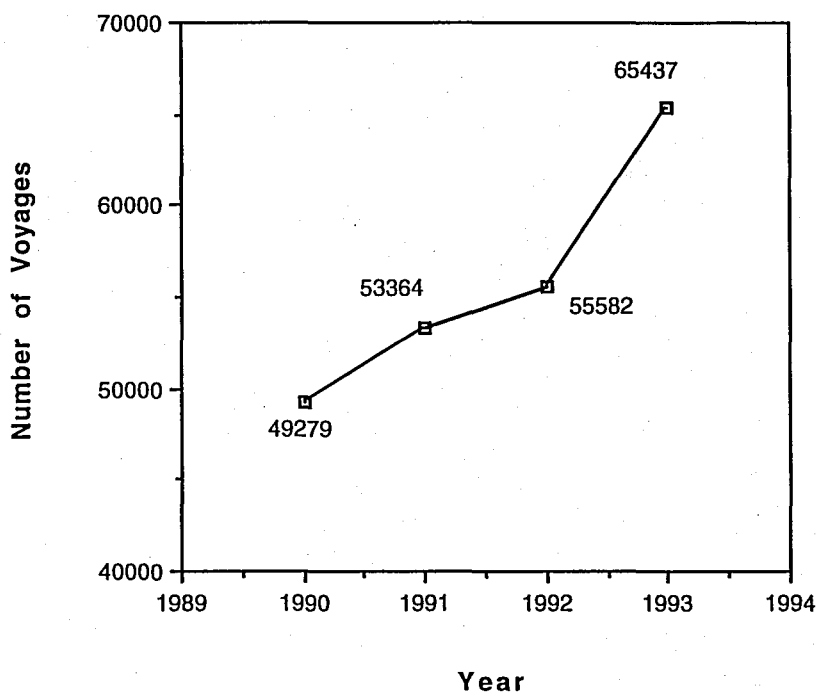
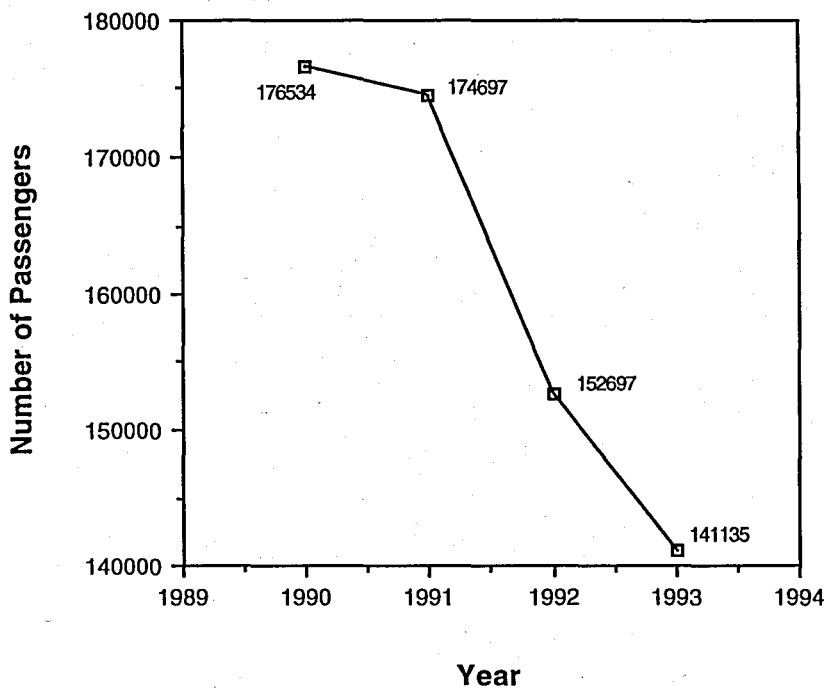

FIGURE 23.1. NUMBER OF VOYAGES PER YEAR



**FIGURE 23.2. NUMBER OF PASSENGERS CARRIED PER YEAR**

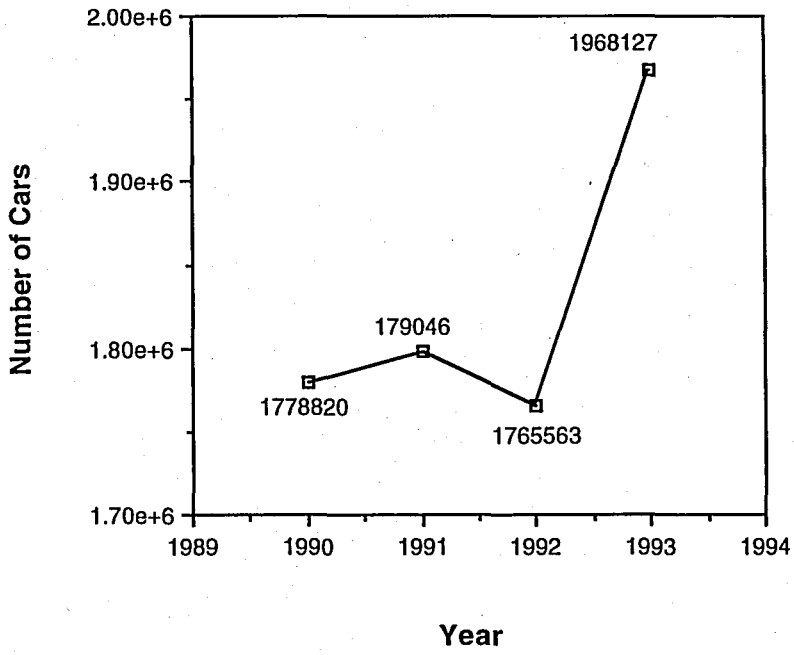

FIGURE 23.3. NUMBER OF CARS CARRIED PER YEAR

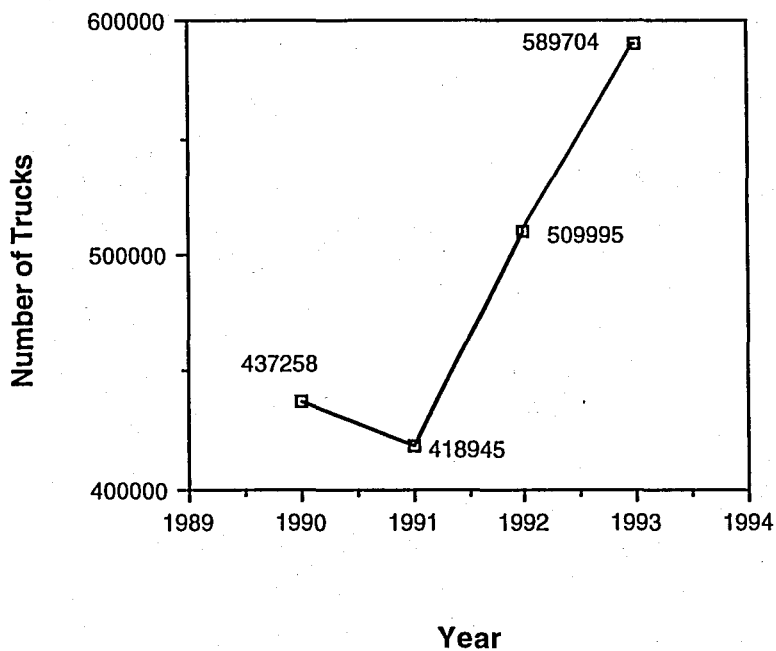
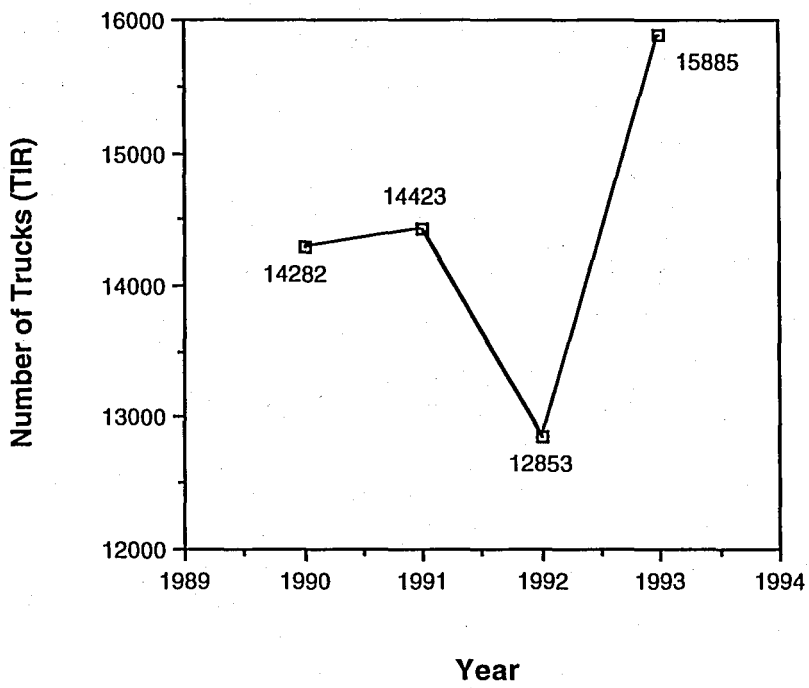

FIGURE 23.4. NUMBER OF TRUCKS CARRIED PER YEAR



**FIGURE 23.5. NUMBER OF TRUCKS (TIR) CARRIED PER YEAR**

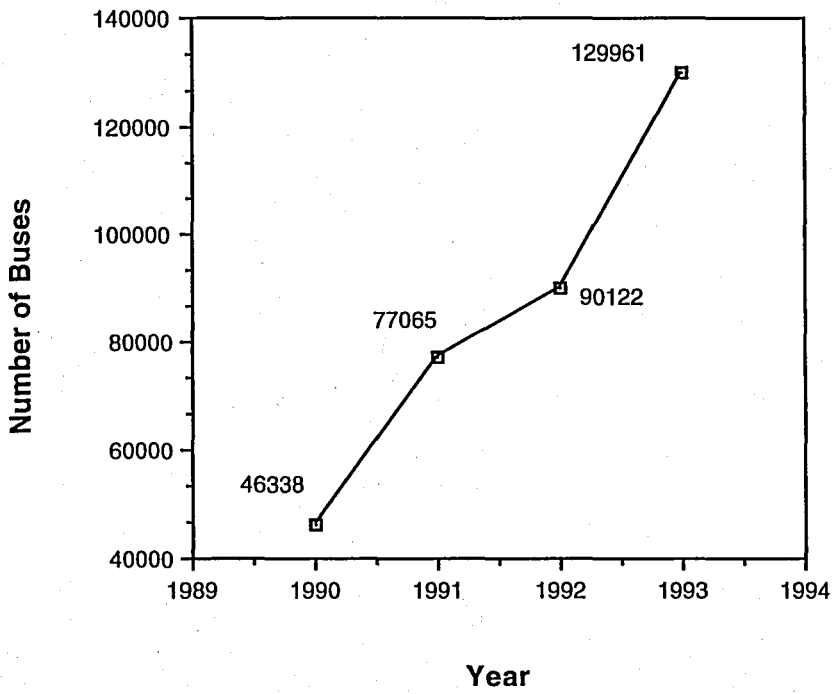

FIGURE 23.6. NUMBER OF BUSES CARRIED PER YEAR

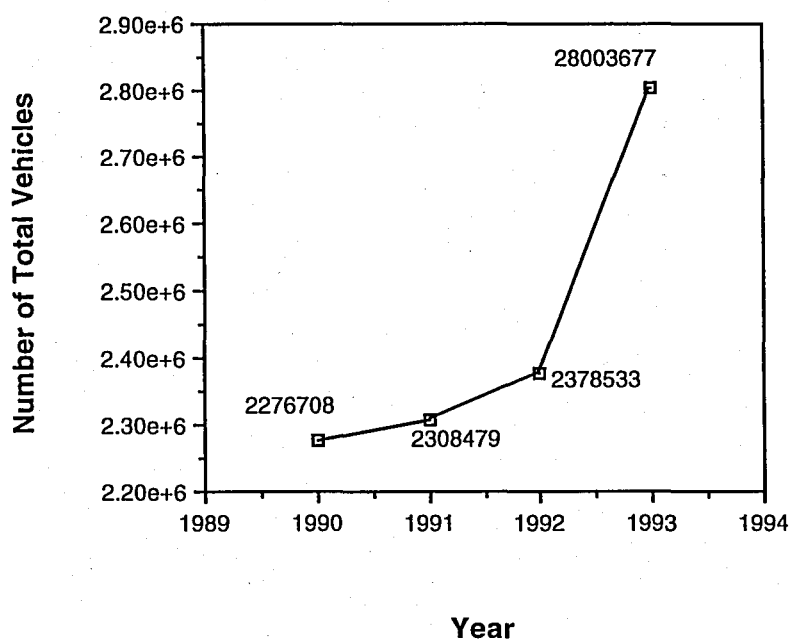

FIGURE 23.7. NUMBER OF TOTAL VEHICLES CARRIED PER YEAR

## 24. IZMIT BAY CROSSING

### 24.1. Introduction

The General Directorate of Highways (KGM), Republic of Turkey is planning to implement a motorway project (the "Project") between Dilovasi (Izmit) and Orhangazi, on a Concession Contract basis, (i.e. Build-Operate-Transfer or BOT) in accordance with Law No. 3465, "Granting Concession to Establishments Other Than General Directorate of Highways for Construction, Maintenance and Operation of Highways (Motorways) With Controlled Access", and its implementation regulation No. 93/4186. This project comprises a portion of the Istanbul-Bursa-Izmir Motorway, which is a strategic link in the Turkish National Highway network. The Project includes a high-level bridge crossing Izmit Bay at a point where shore-to-shore distance is about 46 km of connecting motorway [45].

The bridge and the motorway are to be in full operation within four years following the signing of the agreement with the chosen developer, expected to occur about the beginning of 1995.

### 24.2. The Project Scope

As stated in prequalification document, the main structure of the project will be a high-level bridge across Izmit Bay, with provision for a marine navigational channel. The specific design criteria can be defined such as [45]:

- (a) bridge structure;
- (b) navigation channel;
- (c) side spans;

- (d) pier protection;
- (e) roadway grades, widths and vertical clearances;
- (f) approach roads (the motorway);
- (g) toll collection facilities;
- (h) design provisions to ensure the target service life; and,
- (i) maintenance facilities and procedures to ensure full serviceability throughout the service life.

The Izmit Bay bridge is planned to be a six lane (2x3) facility, as is the Motorway. The new motorway will include an interchange on motorway 0-4 near Dilovasi, a 3 km motorway section from this interchange to Izmit Bay, and approximately a 43 km section of motorway running southerly to Orhangazi as shown in *Figure 24.1*. New interchanges are proposed at the new motorway junction with existing State Highway D-130 and at the southern terminus of the Project.

The location of the bridge across the Bay is proposed at the narrowest stretch of open water, and is fairly obviously defined within a narrow corridor. The actual length of the bridge shall be determined by the design of the selected developer

## **A. The Bridge**

The Bridge will cross Izmit Bay on a straight alignment between Kaba Burun on the north side and Dil Burnu on the south. The bridge will carry six lanes of traffic (three lanes in each direction) with pedestrian sidewalk on each side. The overall bridge length including viaduct spans on the south shore is about 4000 meters and its overall width can be assumed for planning purposes to be 35 meters.

### **A.1. Bridge alignment and geometry**

The bridge alignment will be straight across Izmit Bay. On the north shore, the bridge will be founded on the limestone rock promontory at Kaba Burun. The bridge alignment at the south shore will be on the west side of an existing naval communications facility. The clear distance across the Bay between the north and south shores on the bridge alignment is about 3 km.

### **A.2. Marine and navigational conditions**

According to published hydrographic mapping as shown in *Figure 24.2*, the maximum water depth along the planned bridge alignment is about 60 meters near the south end of the crossing. The water depth along the north half of the crossing varies from about 30

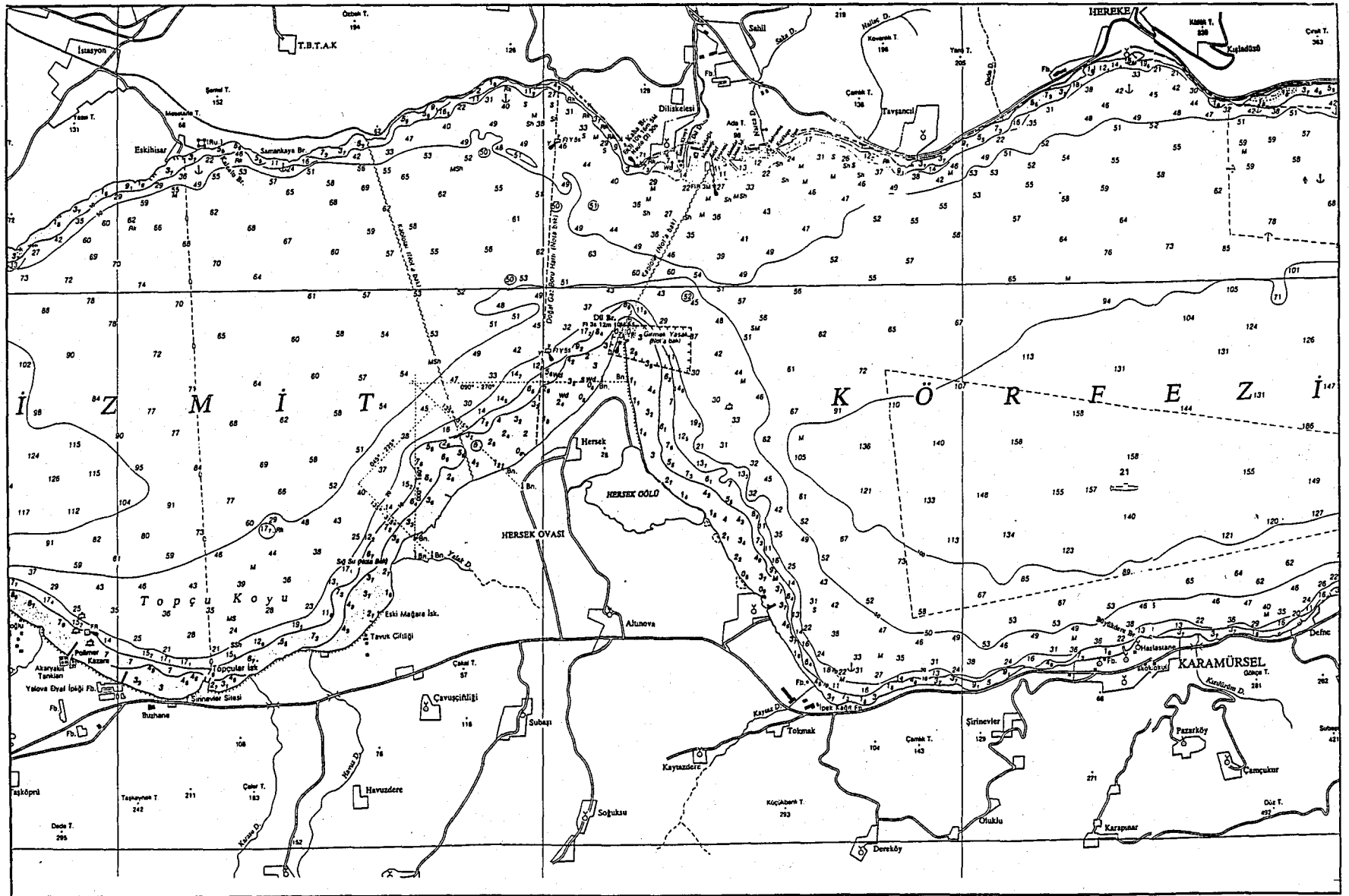
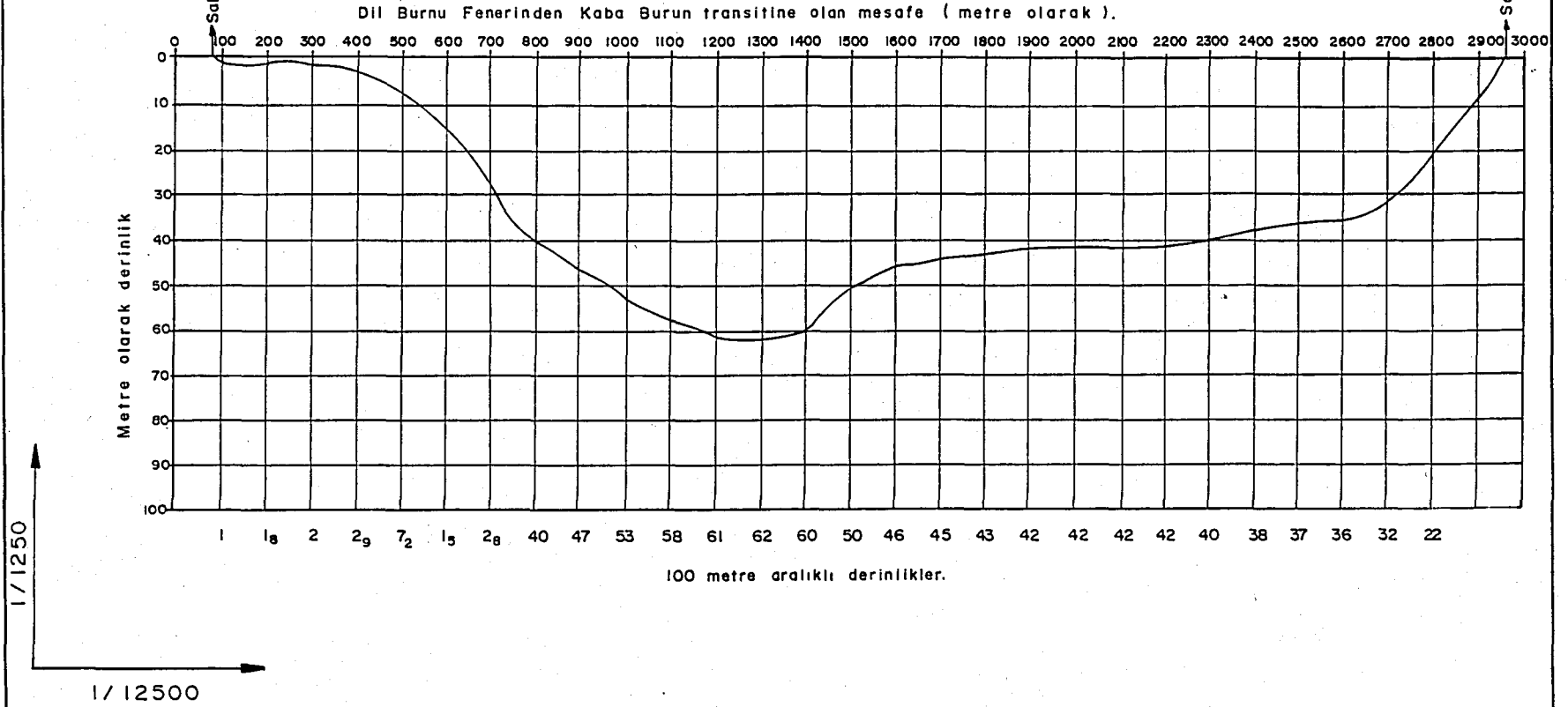

FIGURE 24.1. IZMİT BAY (Courtesy of KGM)

# Dil Burnu Fn. ile Kaba Burun Feneri Arası Boy Profili



Güney Doğu - Kuzey Batı Yönünde Görünüm

FIGURE 24.2. WATER DEPTH ALONG THE BRIDGE ALIGNMENT (Courtesy of KGM)

meters to 50 meters. Whereas a steep sea bed profile occurs near the north shore, there is a shallow underwater shelf near the peninsula on the south shore.

The navigational clearances in Izmit Bay will accommodate both commercial ships as well as navy vessels. The minimum horizontal and vertical clearances will be specified by KGM.

Protection islands and/or secondary protection structures surrounding the bridge piers will be specified to protect them from accidental ship impact.

### A.3. Seismic conditions

The 1500 km long North Anatolian seismic fault zone extends from eastern Turkey to mainland Greece and can be divided into three strands: southern, middle and northern. The northern strand passes beneath the northern half of the Marmara Sea. Izmit Bay is considered to be part of this seismic fault system.

In Turkey, seismic zoning follows the convention of the most severe zone being called Zone 1 and the least severe called Zone 4. Following this convention, Izmit Bay falls within the most severe seismic zone (Zone 1), within which horizontal ground acceleration coefficients are greater than 40 per cent of acceleration due to gravity.

The following statements are abstracted from available reports on the seismic conditions prevailing in Izmit Bay [45]:

- (a) The proximity of the Izmit Bay Crossing site to a major fault system makes a thorough assessment of the earthquake potential imperative for the safety of the bridge.
- (b) Izmit Bay has been the site of several seismic events with intensities VIII and above, including the 1984 Great Istanbul earthquake with a maximum intensity of VIII - IX. The 1963, the Yalova-Çınarcık earthquake of magnitude  $M_s$  6.4 took place within 20 km to 40 km of the bridge site.
- (c) The envisaged bridge axis crosses an active west-east seismic fault near the south shore of the planned bridge. It is speculated that this fault was ruptured by the Great Istanbul earthquake in 1894 and also activated by the more recent 1963 earthquake. Another relatively inactive seismic fault occurs near the north shore of the crossing.
- (d) For structures founded on soils susceptible to liquefaction, a geotechnical evaluation of liquefaction potential will be required.
- (e) For structures with foundations on both sides of the fault trace, the asynchronous nature of the ground motion should be considered.

(f) Since the Marmara Sea is a tsunamigenic region, a tsunami wave propagation study should be conducted for the design of off-shore and/or low altitude on-shore structures.

(g) Bridge piers should be located at an adequate distance from the strike of an active earthquake fault to protect their integrity in the event of earthquake.

#### **A.4. Geotechnical conditions**

Published geological data shows:

(a) The promontory on the north side of the crossing is crataceous limestone.

(b) The soil strata under the sea bed on the northern portion of the Dil Burnu south-shore peninsula, consist largely of deep alluvial soils. There is no indication at what depth bed-rock may be encountered.

Deep geotechnical bore-hole explorations are necessary to determine the depth of the alluvial soils and their potential susceptibility to liquefaction under earthquake effects. The flat terrain on the Dil Burnu (south) side of the bridge encompasses a lagoon-like, indicating a very high water table.

#### **A.5. Wind effects**

Very high winds prevail in Izmit Bay. Wind conditions may be more severe than those prevailing in the Bosphorus, since Izmit Bay is an open area.

Suitable testing for wind effects should be identified to deal with the advanced level of investigation required for a bridge of the magnitude envisaged.

#### **A.6. Existing constraints**

Constraints affecting the bridge include but are not limited to the following:

##### **(1) North Shore Constraints**

(a) The village of Dilovasi directly north of the planned bridge;

(b) An active railway tunnel for the dual rail track serving the primary rail connection between Ankara and Istanbul;

(c) An abandoned tunnel for a single track railway close to the coastline;

(d) An active quarry operation on the axis of the bridge alignment at the north coastline.

##### **(2) South Shore Constraints**

(a) A naval (military) communications center at the tip of the peninsula;

(b) Small residential buildings in the village on the peninsula;

(c) A lagoon-like lake within the peninsula, the west bank of which coincides with the planned bridge alignment.

#### **A.7. Design and code requirements**

The bridge will be designed for a total service life of 100 years. Code requirements will be similar to those used for the design of the existing Fatih (Second Bosphorus) Bridge. This project will be available to the International Technical Specifications for Highway Bridges, General Directorate of Highways, Turkey.

#### **A.8. Preferred bridge configuration**

The choice of bridge configuration for the Izmit Bay crossing should be determined on the basis of the following criteria, consistent with economic considerations:

- (a) Structural Flexibility to accommodate seismic movements, including asynchronous motions.
- (b) Minimization of the number of piers obstructing the sea channel.
- (c) Adequate horizontal navigational clearance for both commercial and navy vessels.

A long-span cable-supported bridge (suspension, cable-stayed or hybrid) is deemed to meet the above criteria, although this should not be construed as the exclusion of other types of bridges.

### **B. The Motorway**

The standards to which the new motorway will be designed and constructed will generally comply those being presently utilized on other sections of the Istanbul-Bursa-Izmir motorway. There will likely be a number of viaducts, bridges, and other structures to be constructed through the mountainous section south of the State Highway D130 to Orhangazi, depending on the chosen route. There are various geological and topographic mapping data available, likely not to the degree necessary to adequately plan and cost the motorway. The proponents may therefore be required to conduct the necessary supplementary field studies, in order to satisfy themselves that the characteristics of the location of the motorway they would choose are accounted for in their cost estimations and work schedules. All relevant information that is available from KGM will be given to the proponents at the commencement of the tendering period.

## 25. DESIGN ALTERNATIVES FOR IZMIT BAY CROSSING

### 25.1. Introduction

The main objectives for the planning of different alternatives is to find the most feasible alternative with respect to:

- (a) cost
- (b) cost/benefit analysis

Before we reach a decision about the design, we have to consider Principle Link Alternatives, Possible Link Structures and Possible Traffic solutions. *Figure 25.1* is a simplified representation of possible alternatives of the fixed link, including [46]:

- (a) A bridge, a tunnel, half bridge and half tunnel, or a combination of bridge/tunnel/bridge.
- (b) The bridges can be constructed as low-level, high-level or floating bridges and the tunnels by shield driving or as immersed or floating tunnels.
- (c) It should be distinguished between a pure railway link, pure road link or a combination railway and road link.
- (d) The quality of the planned infrastructure has to be discussed, namely a single-track or a two-track railway line and a four-lane or six-lane.

For the Izmit Bay Crossing, low bridge and floating bridge alternatives drop because of the navigation channel obligation. Considering the geological conditions, tunnel alternatives also drop. The floating tunnel may be taken into consideration but the vertical clearance needed of at least 25 meters between the sea level and the tunnel makes the floating tunnel alternative unfeasible for the Izmit Bay. Since too much piers needed for the construction, plate girder and arch bridges are not taken into consideration. The Izmit Bay Crossing is planned to be six lane (2x3) facility as is the Motorway.

Principle Link Alternatives

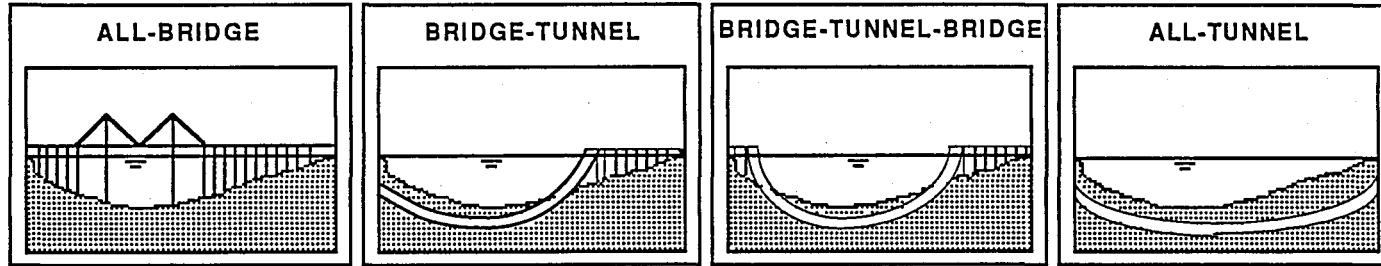

Possible Link Structures

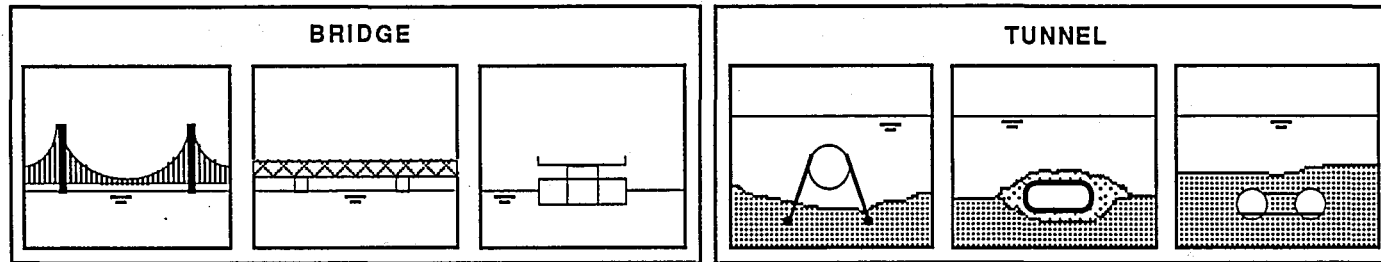

Possible Traffic Solutions

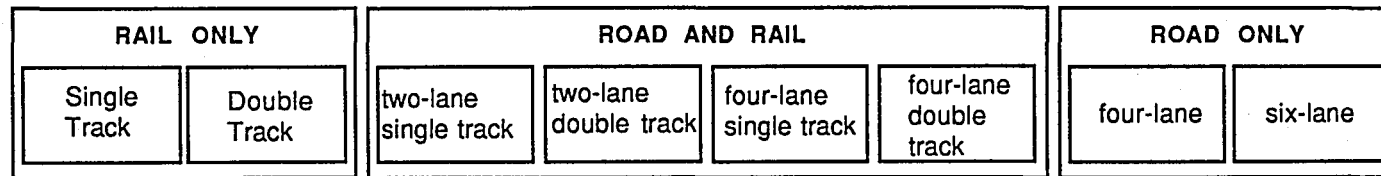

FIGURE 25.1. OVERVIEW OF POSSIBLE LINK VERSIONS

The remaining alternatives are Suspension Bridge, Cable-Stayed Bridge and Hybrid Bridge.

## 25.2. Alternative No.1 - Suspension Bridge

As shown in *Figure 25.2*, the bridge has a main span of 2000 meters and side spans of 500 meters to each side. If it is constructed, it will have the longest main span in the world. With short side spans, the sag of the side span cable becomes small and this influences favorably the axial stiffness. The  $f_m/l_m$  ratio is 0.14 which is economically favorable

The steel deck is of aerodynamic shape as shown in *Figure 25.3*. The carriage way has three traffic lanes and a walkway in each direction. The distance between the cable planes is 26 meters and the depth of the box girder is 3.40 meters. Diaphragms are placed 4.8 meters apart.

The steel towers shown in *Figure 25.4* are 270 meters high above the sea level and are in H-shapes. The three struts are placed between the legs of a tower. The use of concrete as an alternative material to steel in the towers is dismissed on account of the design problems associated with earthquake loading, as well as the belief that erection shall take longer and thus result in overall higher costs. The steel option is chosen also for the required flexibility.

In order to avoid endangering the bridge integrity by ship impact, the piers are surrounded by artificial reef system. *Figure 25.5* shows the proposed reef system.

The provision of the artificial reefs is found to be a cost competitive arrangement compared to structural strengthening of the bridge piers for higher impact loads. The reefs are assumed to be constructed from excavated kill, post/late glacial sand and it is protected by outer layers of heavy rock armor to provide protection against wave, current and ice actions. The artificial reef system is designed by considering the requirement that the direction of the reefs shall be as parallel to the main current as possible, leads to the need for overlapping in order to avoid deeper reef deposits.

The main cable is arranged as a hexagonal grouping of prefabricated strands (PPWS). Comparing with the air Spinning Method (AS), the PPWS is expected to offer a greater speed of construction, lesser sensibility to cross wind, and assured quality control for uniform wire length. However, handling the strands requires heavier equipment at the anchorages and the pylons.

ALTERNATIVE No.1  
SUSPENSION BRIDGE

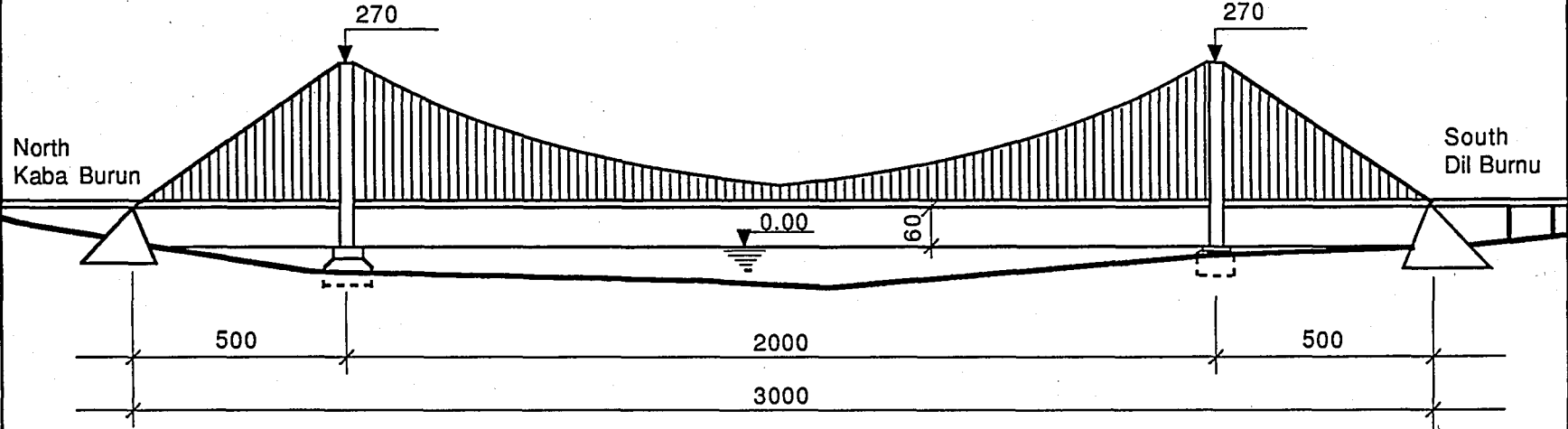

FIGURE 25.2. ELEVATION (In meters)

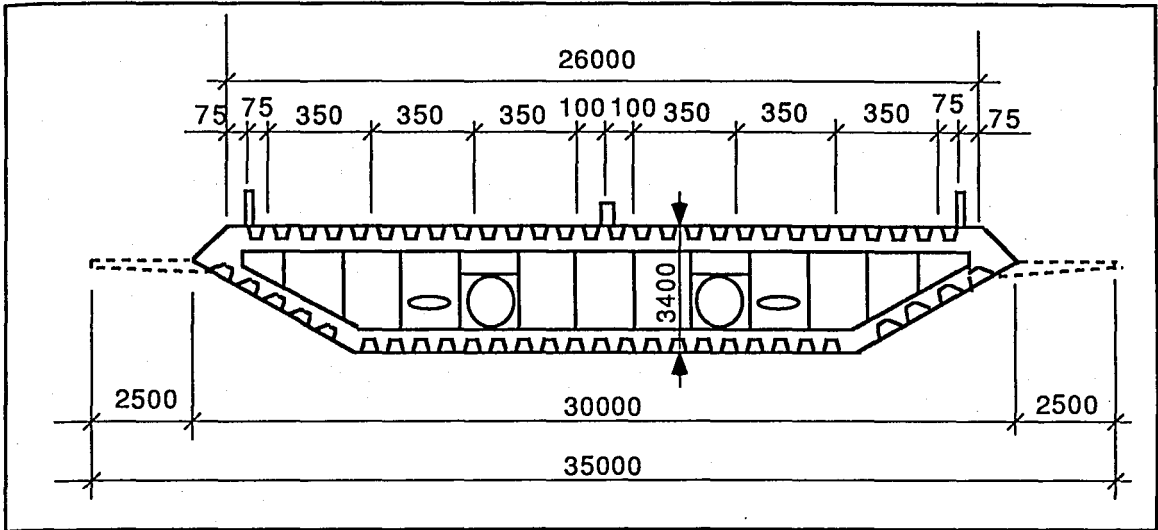

FIGURE 25.3. CROSS SECTION, MAIN SPAN (In mm)

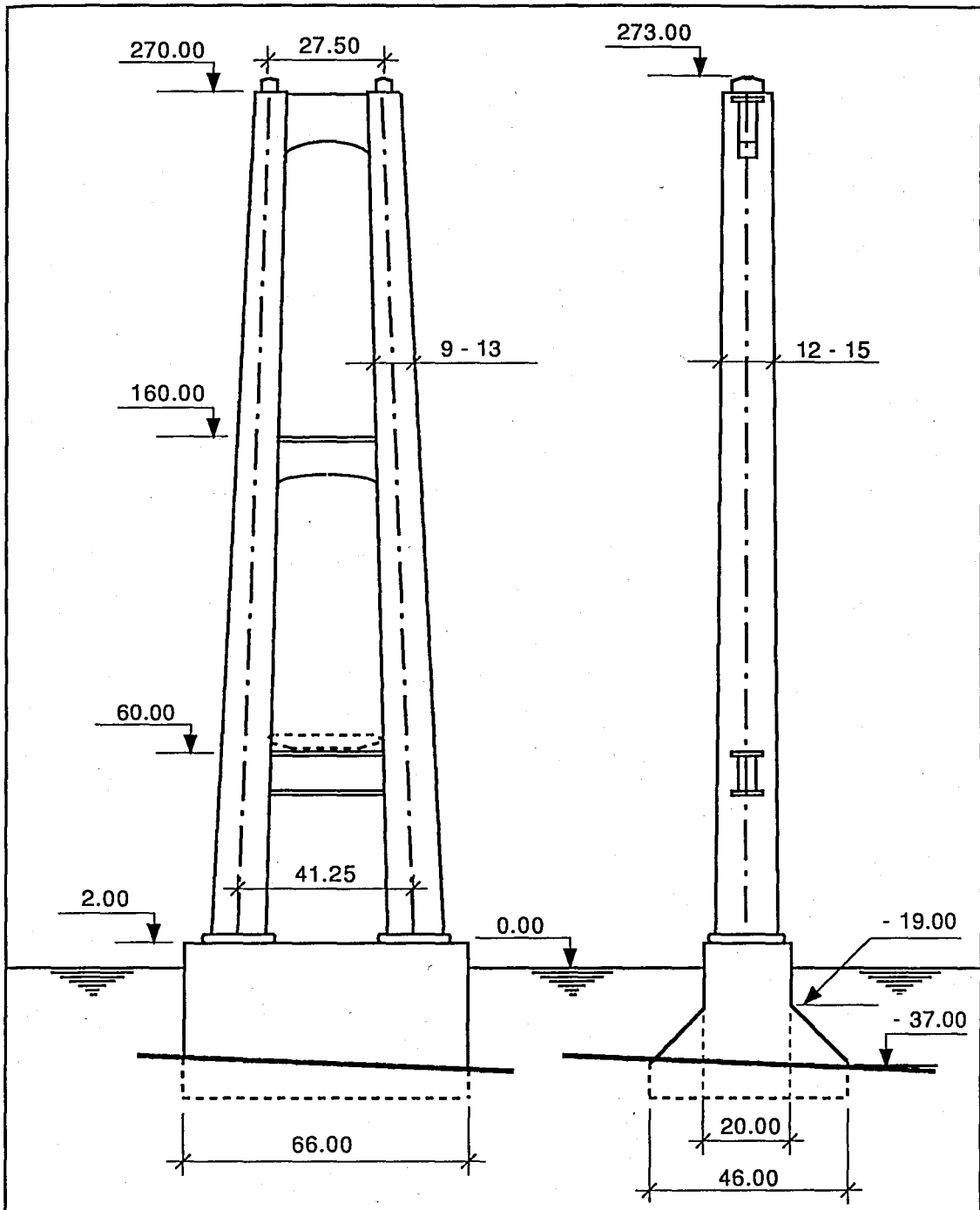

FIGURE 25.4. NORTH TOWER, KABA BURUN SIDE (In meters)

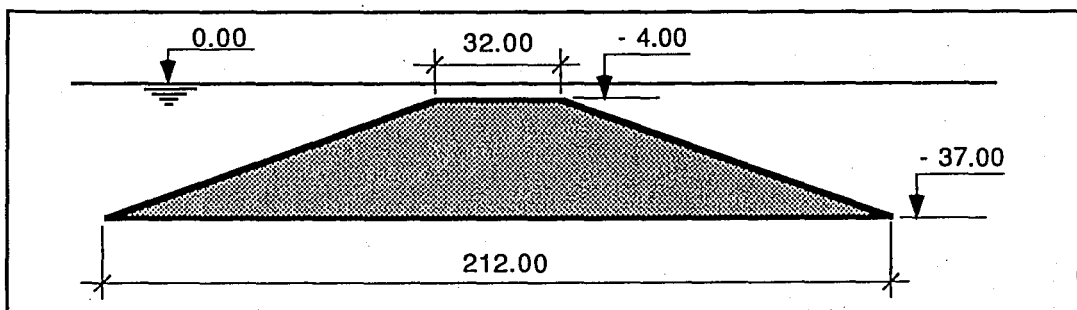

FIGURE 25.5. CROSS SECTION IN REEF, KABA BURUN SIDE (In meters)

Anchor blocks are considered to be the gravity based concept as shown in *Figure 25.6* It consists of a large cellular, sand filled caisson foundation, on top of which inclined legs reach above the bridge girder to accept the main suspension cables into an interior saddle point.

Incremental launching is to be used for the side spans while main span steelwork will be fabricated offsite and floated and lifted into position. The tower blocks will be fabricated offsite and will be lifted up with a self supporting type of crane. The main piers will be constructed by "the Laying-down caisson method" since it reduces the work on the sea and increases the safety and reliability of the construction.

A comprehensive safety plan will be in operation with constant monitoring and reviews being carried out and reported span.

A new system called "Q-free system" is offered for the toll collection.

### **25.3. Q-Free System**

The Q-Free system as it is today, is a total solution for an electronic wireless identification and registration of moving objects, especially designed for automatic registration of vehicles when passing a toll road station or a road pricing checkpoint (Non Stop Tolling). The Q-Free system makes it possible to collect tolls on all types of roads while at the same time enabling the traffic to move freely at the maximum speed allowed.

#### **A. The Q-Free Video System**

The Q-Free Video System, which takes digital video pictures. is an enforcement system designed to fit the Q-Free identification system or as a stand alone system. Along with the Q-Free Video there is an integrated software package highlighting the number plates of each car that violates the system. These pictures will be used by the authorities to bill the offenders [47].

#### **B. The Q-Free Accounting System**

Along with the Q-Free system there is software and routines for subscription, accounting, video, security and communication. This software is designed on industrial standards. This program is designed to keep track of every transaction and update each subscriber's account. This program is menu operated, which makes it easy to customize for the different toll collection systems, including to differentiate on time and place.

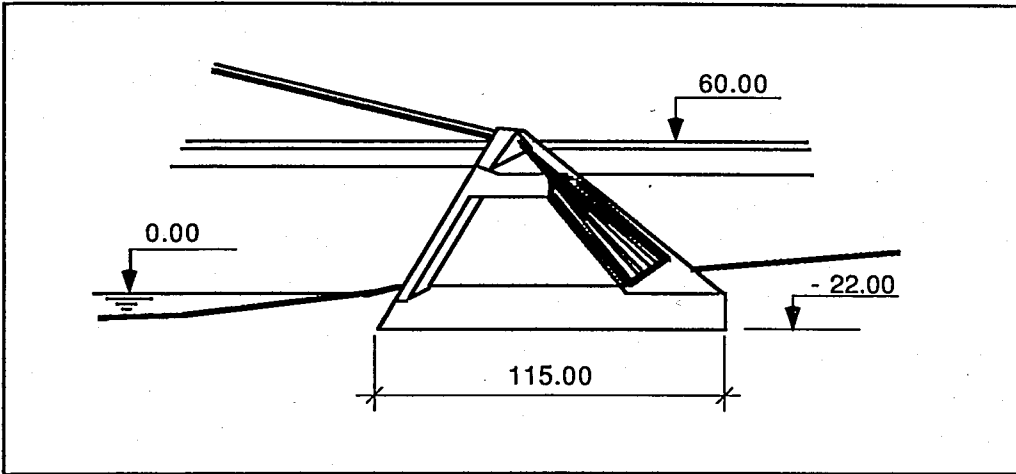

FIGURE 25.6. ANCHOR BLOCK, *DIL BURNU* SIDE (in meters)

The program communicates directly to each toll station or a road pricing checkpoint and may also transfer data between toll companies, banks, post offices etc..

### **B.1. Payment**

The user can, for example, pay the toll in advance (via the local bank or post office). This may be done anonymously by paying cash to your identity code account. The easiest way of paying is a direct deduction from the subscribers account (Auto-Giro), or by receiving a giro in the in the mail.

Next generation tags will probably have on board memory and could be used as a electronic purse. Each time the subscriber passes the check point the toll is automatically drown of your tag. The subscriber is than to "fill up" the purse the same way as today or at the bank or the post office. This is the same as in the smart card system.

### **C. The Highlights of the Q-Free System**

- (a) The Q-Free system can be used for Non Stop Tolling applications on toll roads, road pricing schemes, parking or traffic surveillances.
- (b) The Q-Free Tag is an everlasting, inexpensive, impossible to alter and a completely passive tag (no battery, no semiconductor).
- (c) The Q-Free Registration Unit detects the ID number of each Q-Free Tag with an estimated accuracy of 1 fail each 23 million vehicle.
- (d) the Q-Free Enforcement system is a fast digital video system which is integrated in the Q-Free Registration system. The Enforcement system pictures all vehicles in a rotating memory and stores only the violators.
- (e) The Q-Free Back Office system is a data based accounting system to keep track and update subscribers using the system. It communicates with road sties, bank, post and toll authorities. It automatically backup transactions and prints statistics, forms and payment giros.

## 25.4. Alternative No.2 - Cable-Stayed Bridge

As shown in *Figure 25.7* the bridge has a main span of 1200 meters and 600 meters side spans. The viaducts are traditional prestressed concrete box girders. The bridge girder is steel box girders. This bridge type transmits its weight including live load even in the most adverse condition almost exclusively vertically into the soil. By comparison a suspension bridge requires suitable structures to transmit the main cable forces, which are in the range of the total weight of the bridge, horizontally into the subsoil.

A multi-span cable stayed bridge was considered but rejected because of the reasons as follows:

- (a) Live loads can bend the towers like a free cantilever structure. This increases the effort for towers and develops a huge overturning moment at its foundation in the sea bed.
- (b) Towers have to be located in the middle in the middle of the strait. The risk of ship collisions increases dramatically.
- (c) A continuous deck is not elastic enough to accommodate the specified tectonic ground movements. Link span articulations are required which are weak points concerning maintenance and the risk failure under dynamic conditions.

As shown in *Figure 25.8* the steel bridge deck has an aerodynamic shape. The distance between the cable planes is 26 meters and the depth of the girder is 4.1 meters. Comparing with suspension bridge deck, the girder depth is increased 20 per cent in order to improve the stiffness in the construction stage. The ends of the steel deck are rigidly connected to prestressed multi-box concrete girders.

Basic reflections on the design are as follows;

- (a) A safe foundation should reach soil of greater strength for this purpose piles are adopted.
- (b) The upper parts of the structure should be light to reduce the effects of earthquakes. Therefore the tower footings consist of concrete caissons, and the pylons and the deck of steel structures.
- (c) To resist forces in transverse direction by almost creating only normal forces A-Shaped pylons are chosen. The cables run from both sides of the deck to the bridge center line at the tower heads to form a stiff space frame.

ALTERNATIVE No.2  
CABLE-STAYED BRIDGE

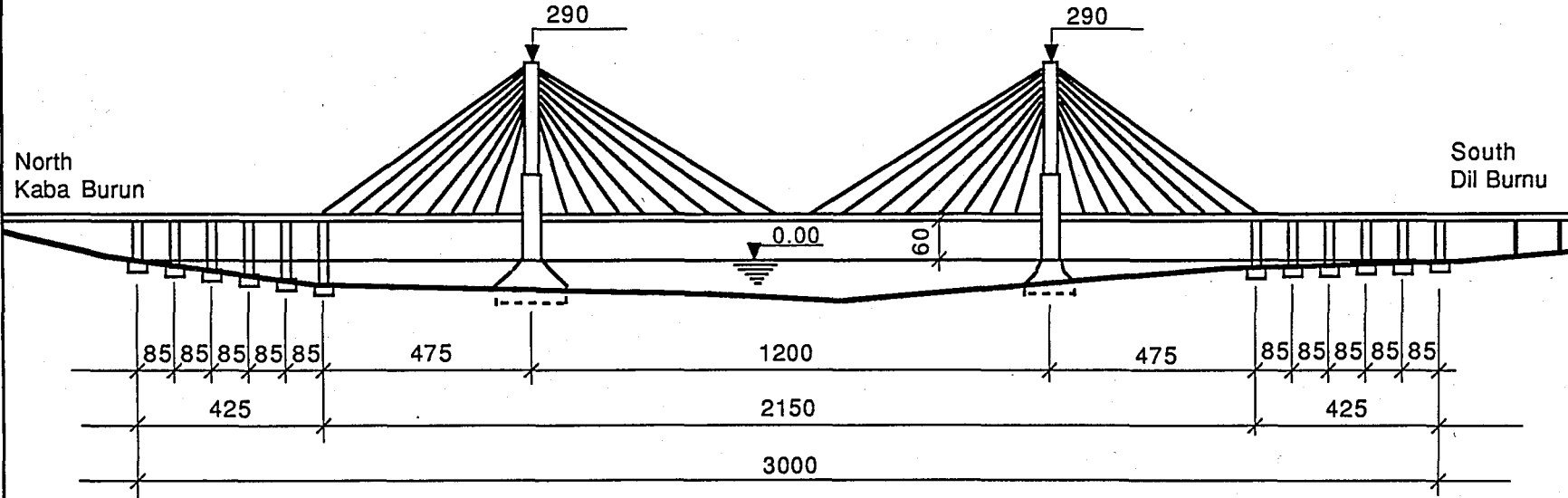

FIGURE 25.7. ELEVATION (in meters)

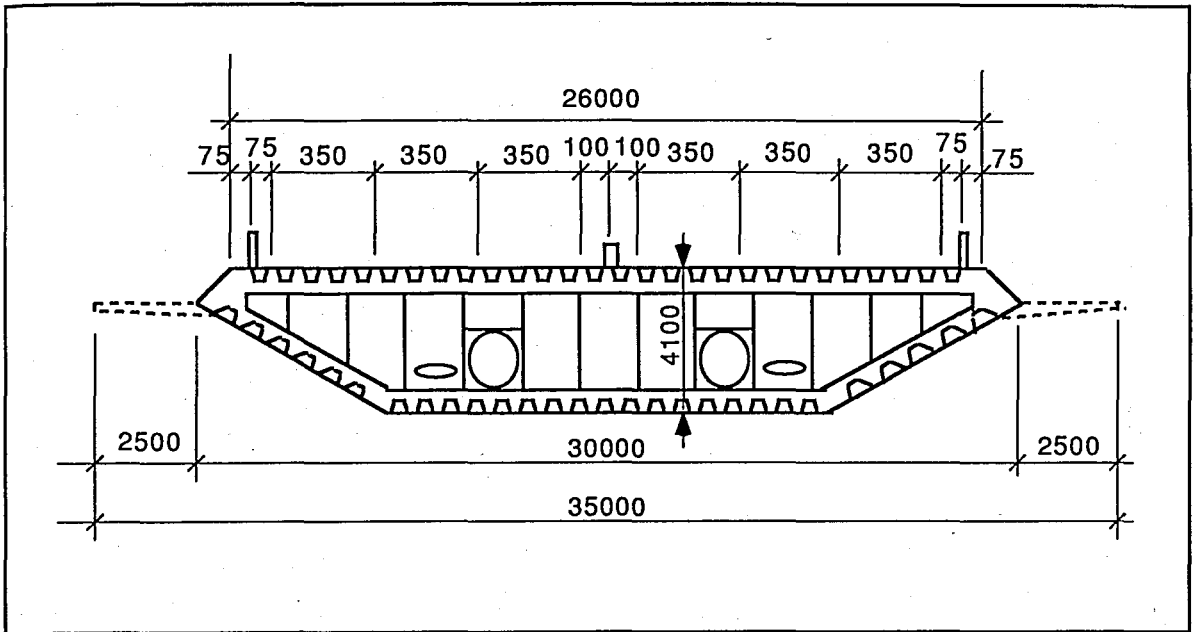

FIGURE 25.8. CROSS SECTION, MAIN SPAN (In mm)

(d) The best way to isolate the deck from dynamic ground excitements as is to support it vertically only by the cable-stays except for the ends of the deck where rigid supports are required.

(e) These ends consist of multi cellular prestressed concrete box girders heavy enough to avoid holding-down measures.

The towers are 290 meter above the sea level and are in A-Shapes as shown in *Figure 25.9*. The water depth amounts 45 and 42 meters respectively. The substructures of the towers are founded on 40 meters long tubular steel piles. The piles are arranged mainly on a circular line to resist in the best way the dominating earthquake load which can act in any direction. The substructure of the pylon consist of reinforced concrete. It reaches up to a level of 60 meters above the sea., 8 meters below the deck.

The tower footing in shape of a truncated pyramid consists of multi-cellular structure, 70 meters in diameter, 25 meters high. Out of this grow two piers which have an upward tapering rectangular cross section. Above the surface of the sea the pair of piers is connected by a hallow box tie beam. Above the tie beam the A-shaped pylon is arranged. Its cross girder is located 60 meters above the sea just before the deck. The legs consist of 12 meters square box section. The wall thickness amounts to 1 meter. Several diaphragms enlarge the stiffness so a ship collision may happen directly against the pylon legs.

The pylon above the cross member is made up of high tensile steel plates, 230 meters high. The pylon leg consists of a 8 meters square box section. At the upper 50 meters the individual leg sections are joined to form the pylon head.

The cables are arranged in two lateral planes to form in elevation a modified fan configuration. Each cable is individually anchored in the tower head and in the deck. The surface of the wires is hot galvanized and the full cables will be high-purity zinc-alloy grouted. In order to avoid oscillation steel transition tubes with rubber vibration dampers at both anchorages are foreseen.

It is very difficulty to erect a so long deck without temporary supports as required according to the specifications. Only balanced cantilever erection can be performed keeping the main span slightly ahead of the side span. A sophisticated sequence of measures is necessary. Auxiliary stays from the pylon top and from the tip of the side span to end pier, temporary fixings of the deck to the pylons, and others are required. The dynamic behavior has to be taken into account for many construction stages. The erection can be simplified when some supports are arranged in the side spans. however, a ship collision must be prevented.

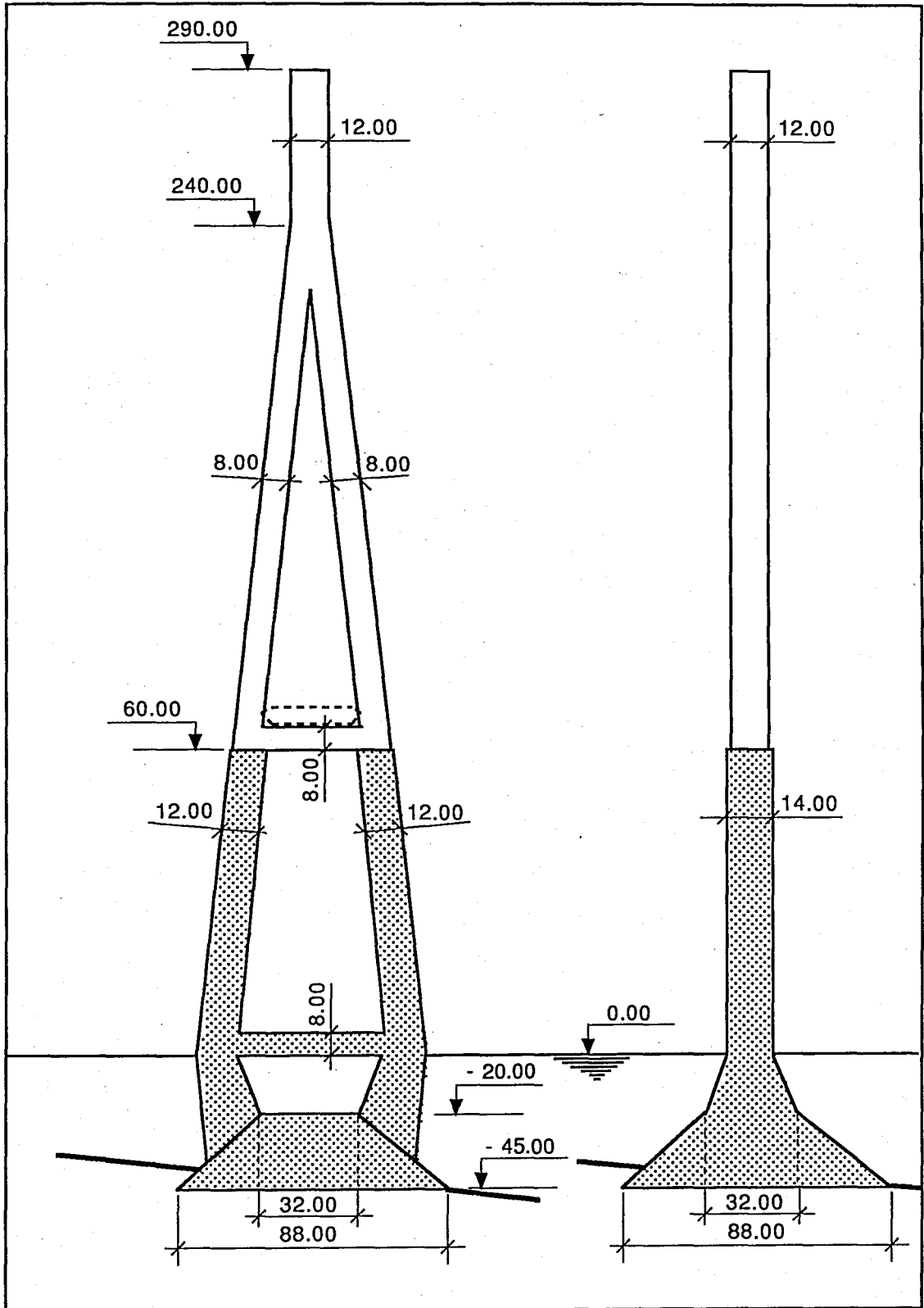

FIGURE 25.9. NORTH TOWER, KABA BURUN SIDE (In meters)

The endangered surfaces of the towers are lined with 0.7 meters thick wooden fenders shown in *Figure 25.10* that can absorb some energy in plastic deformation. Especially at the begin of a crash the peak impact force which lasts only for a fraction of a second can be reduced substantially. The rigid reinforced concrete tower leg structures are designed to withstand the impact loads without further protection curtains

For the approach spans precast concrete box girders, as shown in *Figure 25.11*, with spans 85 meters, may be the most economical solution. Post tensioning will be used in the longitudinal and in the transverse direction. Standardized box segments can be produced and cured in a waterside casting yard and transported by water.

Because of the great water depth (averaging about 50 meters) substructure construction will be costly. No data are available about the foundation conditions; soft soil is assumed which will require pile supported footings. Piers would be constructed in the usual manner, on top of tremie seal concrete inside steel sheetpiling.

### **25.5. Alternative No.3 - Hybrid Bridge**

Compared to a pure suspension system the combined system should lead to material savings due to the following two features:

- (a) The load carried by the stay cables will require less material.
- (b) A more optimum height of the pylon can be used, as the limitations due to stiffness requirements in the suspension system do not apply to the combined system.

The total length of the bridge shown in *Figure 25.12* is 3000 meters with 200 meters main span and 500 meters side spans. The width is 35 meters which carries six lanes.

The streamlined cross section of the deck is chosen to reduce wind forces and to increase the aerodynamic stability of the bridge. The final shape is also selected for specific reason: it has to be adopted to both concrete and steel structures, since the deck is in prestressed concrete in the access spans as shown in *Figures 25.13* and in steel in the central part of the main span as shown in *Figure 25.14*.

The concrete and the steel composite deck, with concrete access spans on close supports extended at a distance of 500 meters from each pylon in the central span, as well as the rigid connection between deck and pylons, increases the structure's rigidity. Wind-induced deflections are drastically reduced. A steel main span is preferred because of its comparative lightness when compared to concrete.

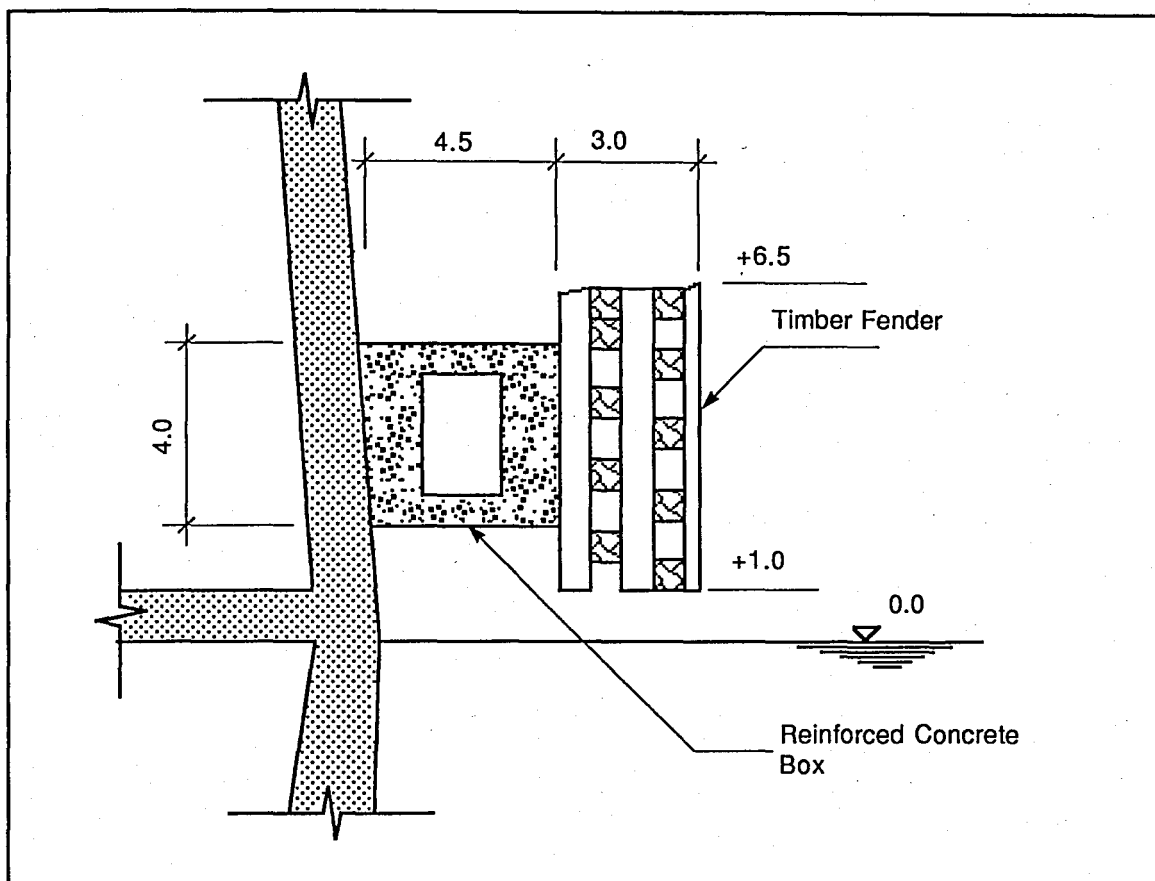

FIGURE 25.10. PIER PROTECTION (in meters)

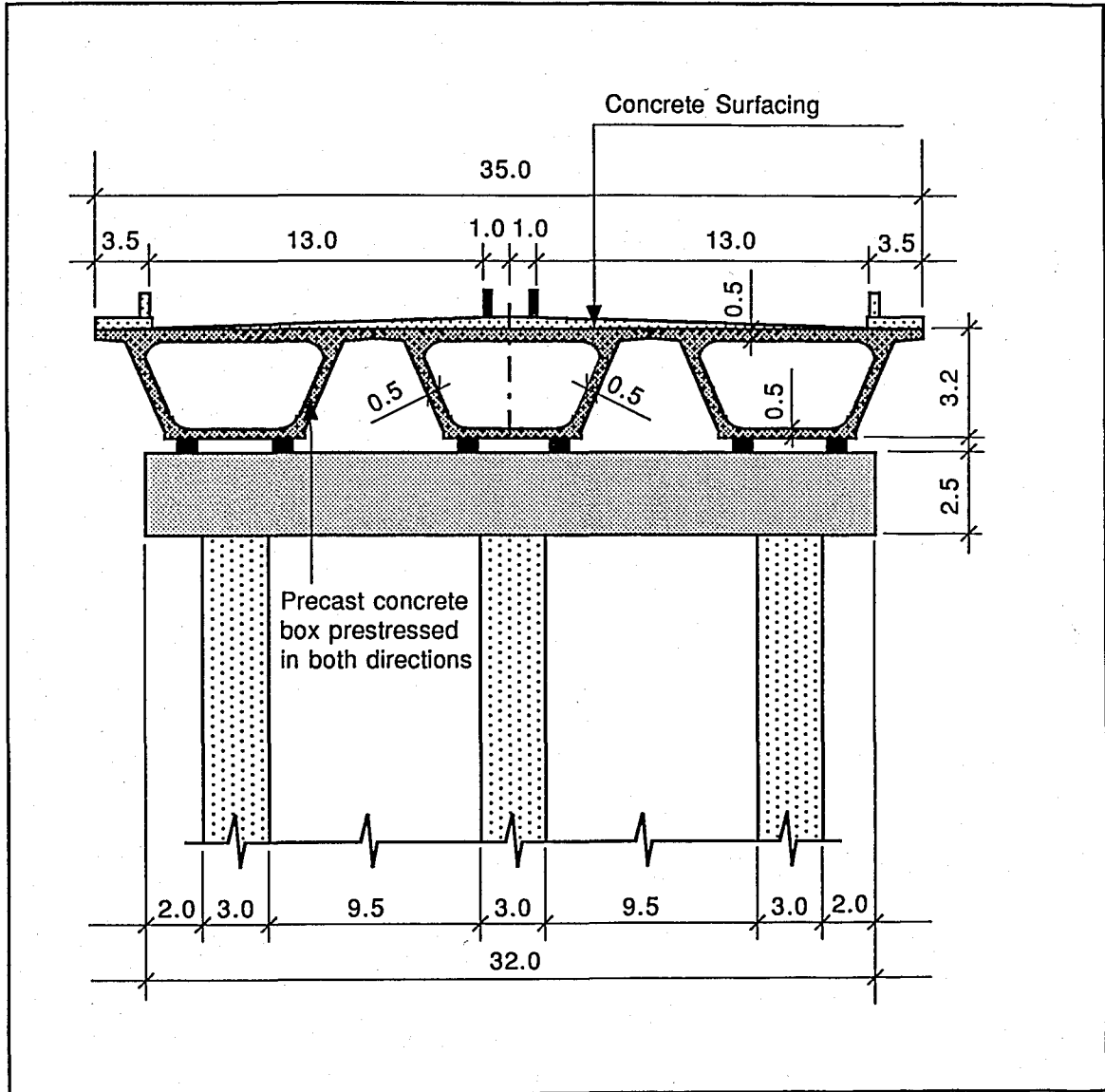

FIGURE 25.11. CROSS SECTION, APPROACH SPANS (in meters)

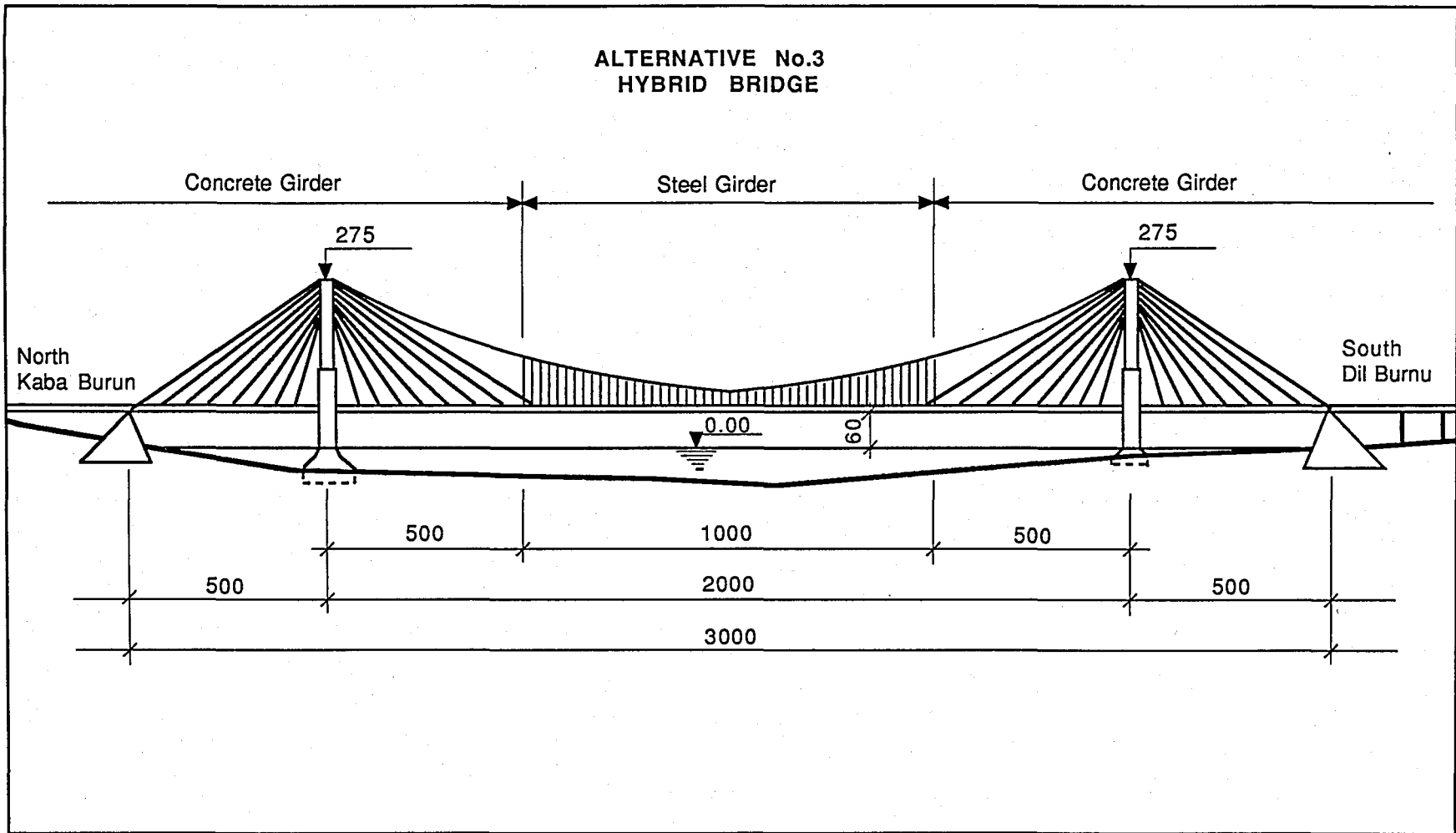

FIGURE 25.12. ELEVATION (In meters)

The side spans shall be able to stand alone and a 5.5 meters high concrete cross section is chosen, that spans 2x500 meters and serves also a counterweight for the unbalanced, self-supported structure. The concrete section is continued in the mid span for 500 meters from each pylon. The height is gradually reduced from 5.5 to 3.8 meters to reduce the weight.

The steel towers shown in *Figure 25.15* are 275 meters high above the sea level and are in A-shapes. The design of towers and pier protectors are same as the towers and pier protectors designed for cable-stayed bridge.

The suspension cable shall exist of single cables, that are combined by a special clamp at the hanger locations. Assembly is done on site similar to stay cables. The cables are anchored in the pylon and the same jacks and mounting equipment can be used for the stay cables and the suspension cables. Another important fact is the possibility to exchange single cables at a later stage, which eliminates one of the weakest characters of suspension bridge.

It seems to be preferable to use cables assembled on deck consisting of PVC coated single strands placed in a strong PVC tube, that will be filled with grouting to assure an alkaline atmosphere as a corrosion protection. The monitoring shall be carefully designed and carried out.

The erection of the structure is relatively simple. Starting from the pylons, progressing outwards in both directions, the two 500 meters - long sections of the deck shall be constructed using traditional cantilever methods with high grade precast concrete segments supported by cable stays anchored to the pylons.

Design alternatives No.1, No.2 and No.3 are very much inspired from the Normandie Bridge in France, Proposed cases for the Rion-Antirion Bridge crossing in Greece [48], [49] and proposed design alternatives for the Great Belt East Bridge in Denmark [50].

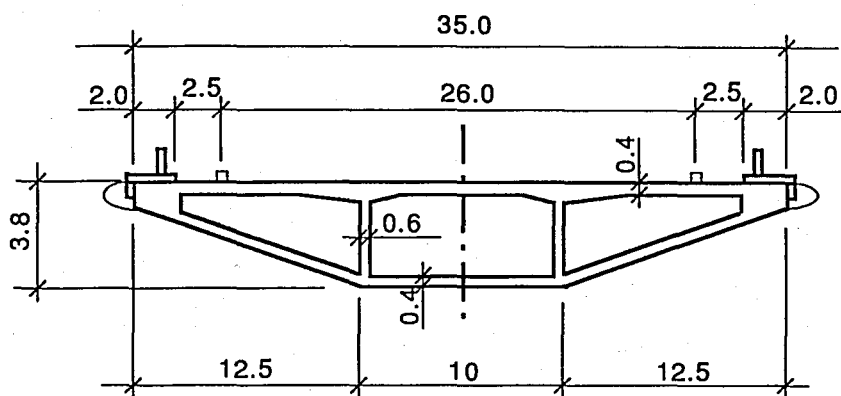

FIGURE 25.13. CROSS SECTION OF THE ACCESS SPAN DECK (In meters)

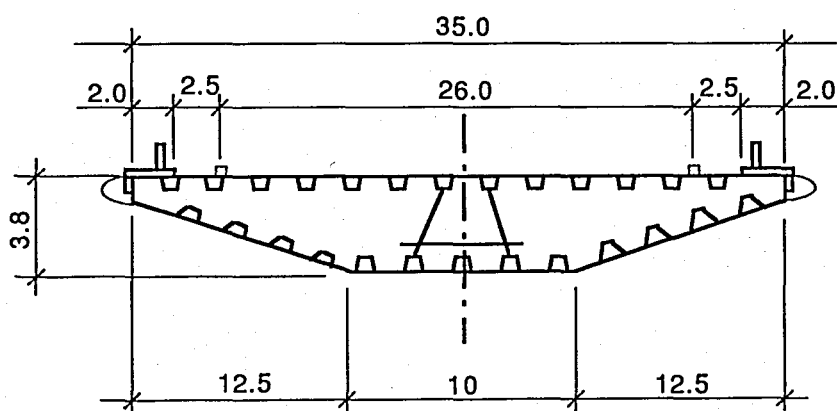

FIGURE 25.14. CROSS SECTION OF THE MAIN SPAN (in meters)

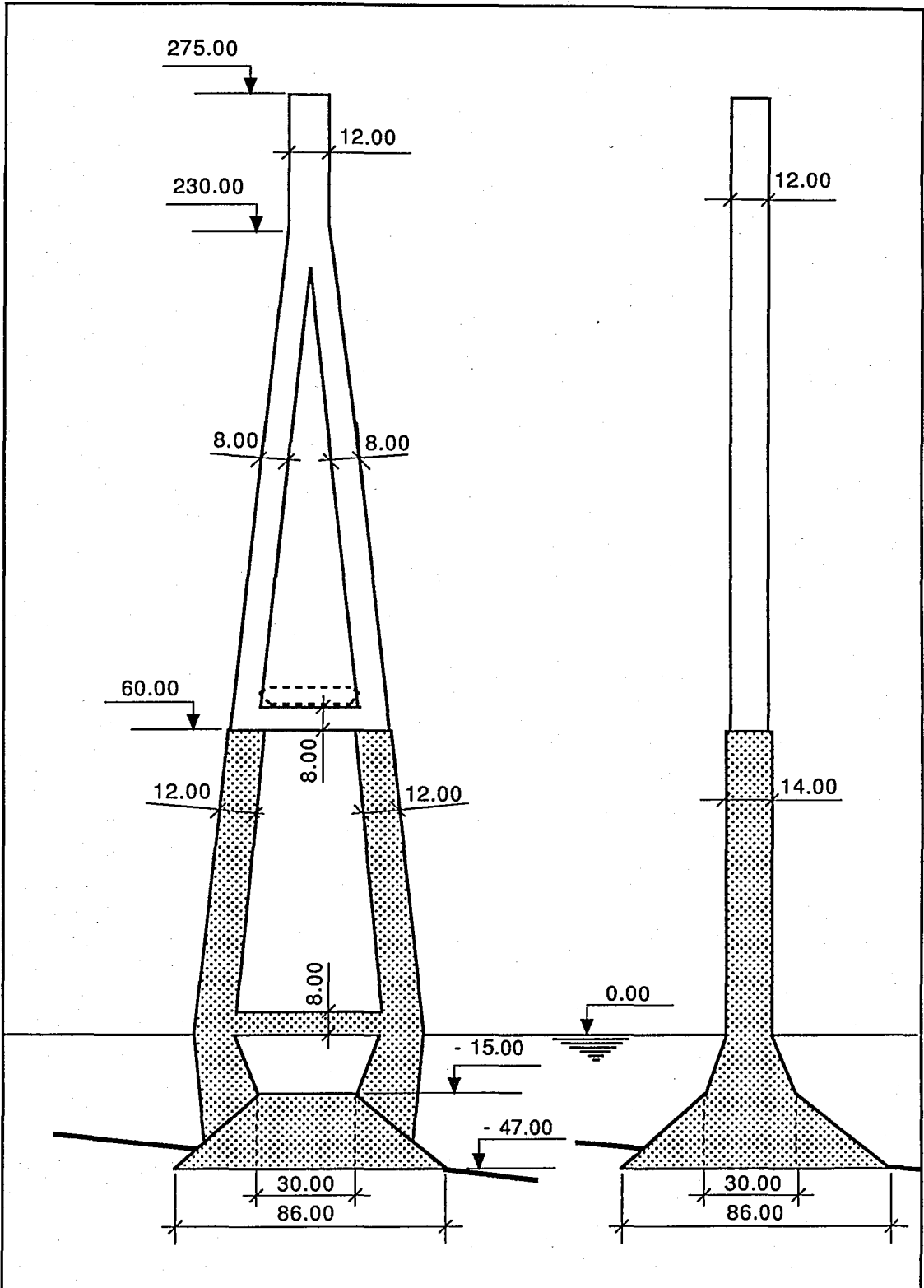

FIGURE 25.15. NORTH TOWER, KABA BURUN SIDE (In meters)

## **26. LOAN PAYMENT ANALYSIS OF THE IZMIT BAY CROSSING**

### **26.1. Preliminary Cost Estimate of the Alternatives**

To calculate preliminary cost of the alternatives proposed for the Izmit Bay Crossing, some assumptions based on case studies are made as follows:

(a) The average cost of structural steel is 1.68 USD per kg. The cost ratio for production, installation, etc. is 1.465. The overall average cost including production, installation, etc. is 2.5 USD per kg.

(b) The average cost of girder, including production, installation, surface treatment, wearing surface, railing, etc. is 3.95 USD per kg (kg represents the amount of steel used in the girder.)

(c) The average cost of cables including installation, surface treatment, etc. is 4.3 USD per kg.

(d) The average cost of Class A concrete is 190 USD per cubic meters. The cost of reinforcing steel is 48 cent per kg. The average cost of concrete including production, installation, materials in it, etc. is 380 USD per cubic meters. The average cost of concrete including prestressed tendons is 460 USD per cubic meters.

(e) Engineering is considered as 10 per cent of the bridge cost.

(f) The average cost of a square meter of the highway the is 150 USD.

(g) The average cost of other items such as anchor blocks, saddles, pier protectors, electric installation, supervision, etc. are scenarios assumed by the writer considering the case studies.

Taking into consideration the above assumptions, preliminary cost estimate the alternatives no.1 to 3 are indicated in *Table 26.1, 26.2 and 26.3* respectively.

As shown in *Table 26.4* cost ratio of the alternative no.3 is the lowest. The cable stayed bridge is much expensive compared to other alternatives, because the required big cables are not yet available and the high pylon is problematic for seismic and wind conditions.

The cost ratio of alternative no.1 and 2 are close together. To reach a more feasible solution, complicated cost estimate should be done after getting information about the ground conditions.

For loan payment analysis, the cost of the alternative no.3 is going to be used. So it can be stated that the overall cost of the project including 46 km highway and viaducts is USD 652 000 000.

## **26.2. Traffic Forecast**

The forecast is done by considering the data taken from the General Directorate of Highways (KGM). The forecast of average daily traffic is shown in *Figure 26.1*. After opening of the bridge in 1999 minimum increase of 4.5 per cent is taken for the forecast of traffic. The data for the forecast of average daily traffic after 1999 is shown in *Table 26.5*.

## **26.3. Loan Payment Analysis**

Based on a weighted average toll fee assumption of USD 15 for a typical vehicle, it is estimated that the total income of the bridge will be about 900 million US Dollars for a seven-year of period between 1999 and 2005 [51].

Such an income is amply satisfactory for the amortization payments of a credit loan in the amount of 728 million US Dollars, at an interest rate of six per cent, as shown in *Figure 26.6*

TABLE 26.1. PRELIMINARY COST ESTIMATE OF ALTERNATIVE No.1

| Items   | Unit           | Amount | Cost (USD)         |
|---|----------------|--------|--------------------|
| Steel in Towers                               | ton            | 31076  | 80 200 000         |
| Steel in Deck                                 | ton            | 26489  | 104 600 000        |
| Cables  | ton            | 32103  | 138 000 000        |
| Concrete Work in Foundations                  | m <sup>3</sup> | 88000  | 33 400 000         |
| Cable Anchorages and Saddles                  |                |        | 24 700 000         |
| Electric Installation                         |                |        | 4 200 000          |
| Administration Building and Custom Facilities |                |        | 4 000 000          |
| Rails, Traffic Signs and Lightining           |                |        | 3 100 000          |
| Supervision                                   |                |        | 23 600 000         |
| Pier Protection                               |                |        | 5 200 000          |
|   |                |        | 418 500 000        |
| Engineering                                   |                |        | 41 850 000         |
| <b>Bridge Cost</b>                            |                |        | <b>460 350 000</b> |
| Highway                                       | km             | 43     | 225 750 000        |
| <b>Total Project Cost</b>                     |                |        | <b>686 100 000</b> |

TABLE 26.2. PRELIMINARY COST ESTIMATE OF ALTERNATIVE No.2

| Items   | Unit           | Amount | Cost (USD)         |
|---|----------------|--------|--------------------|
| Steel in Towers                               | ton            | 15640  | 39 100 000         |
| Steel in Deck                                 | ton            | 24682  | 97 500 000         |
| Cables  | ton            | 11460  | 49 300 000         |
| Concrete Work in Towers                       | m <sup>3</sup> | 396000 | 150 500 000        |
| Cable Anchorages and Saddles                  |                |        | 16 200 000         |
| Electric Installation                         |                |        | 4 200 000          |
| Administration Building and Custom Facilities |                |        | 4 000 000          |
| Rails, Traffic Signs and Lightining           |                |        | 3 100 000          |
| Supervision                                   |                |        | 23 600 000         |
| Pier Protection                               |                |        | 3 600 000          |
| <b>Approach Spans</b>                         |                |        |                    |
| Concrete Work in Substructure                 | m <sup>3</sup> | 84498  | 32 000 000         |
| Concrete work in Superstructure               | m <sup>3</sup> | 30600  | 13 500 000         |
|   |                |        | 436 600 000        |
| Engineering                                   |                |        | 43 660 000         |
| <b>Bridge Cost</b>                            |                |        | <b>480 260 000</b> |
| Highway                                       | km             | 43     | 225 750 000        |
| <b>Total Project Cost</b>                     |                |        | <b>706 010 000</b> |

TABLE 26.3. PRELIMINARY COST ESTIMATE OF ALTERNATIVE No.3

| Items   | Unit           | Amount | Cost (USD)         |
|---|----------------|--------|--------------------|
| Steel in Towers                               | ton            | 15750  | 39 400 000         |
| Steel in Deck                                 | ton            | 12300  | 48 600 000         |
| Cables  | ton            | 19900  | 85 600 000         |
| Concrete Work in Towers                       | m <sup>3</sup> | 230836 | 87 700 000         |
| Concrete Work in Deck                         | m <sup>3</sup> | 116300 | 53 500 000         |
| Cable Anchorages and Saddles                  |                |        | 34 200 000         |
| Electric Installation                         |                |        | 4 200 000          |
| Administration Building and Custom Facilities |                |        | 4 000 000          |
| Rails, Traffic Signs and Lightining           |                |        | 3 100 000          |
| Supervision                                   |                |        | 23 600 000         |
| Pier Protection                               |                |        | 3 600 000          |
|   |                |        | 387 500 000        |
| Engineering                                   |                |        | 38 750 000         |
| <b>Bridge Cost</b>                            |                |        | <b>426 250 000</b> |
| Highway                                       | km             | 43     | 225 750 000        |
| <b>Total Project Cost</b>                     |                |        | <b>652 000 000</b> |

TABLE 26.4. COST COMPARISON

| <b>Alternate</b> | <b>Description</b>  | <b>Cost Ratio</b> |
|------------------|---------------------|-------------------|
| <b>1</b>         | Suspension Bridge   | 1.080             |
| <b>2</b>         | Cable-Stayed Bridge | 1.127             |
| <b>3</b>         | Hybrid Bridge       | 1.000             |

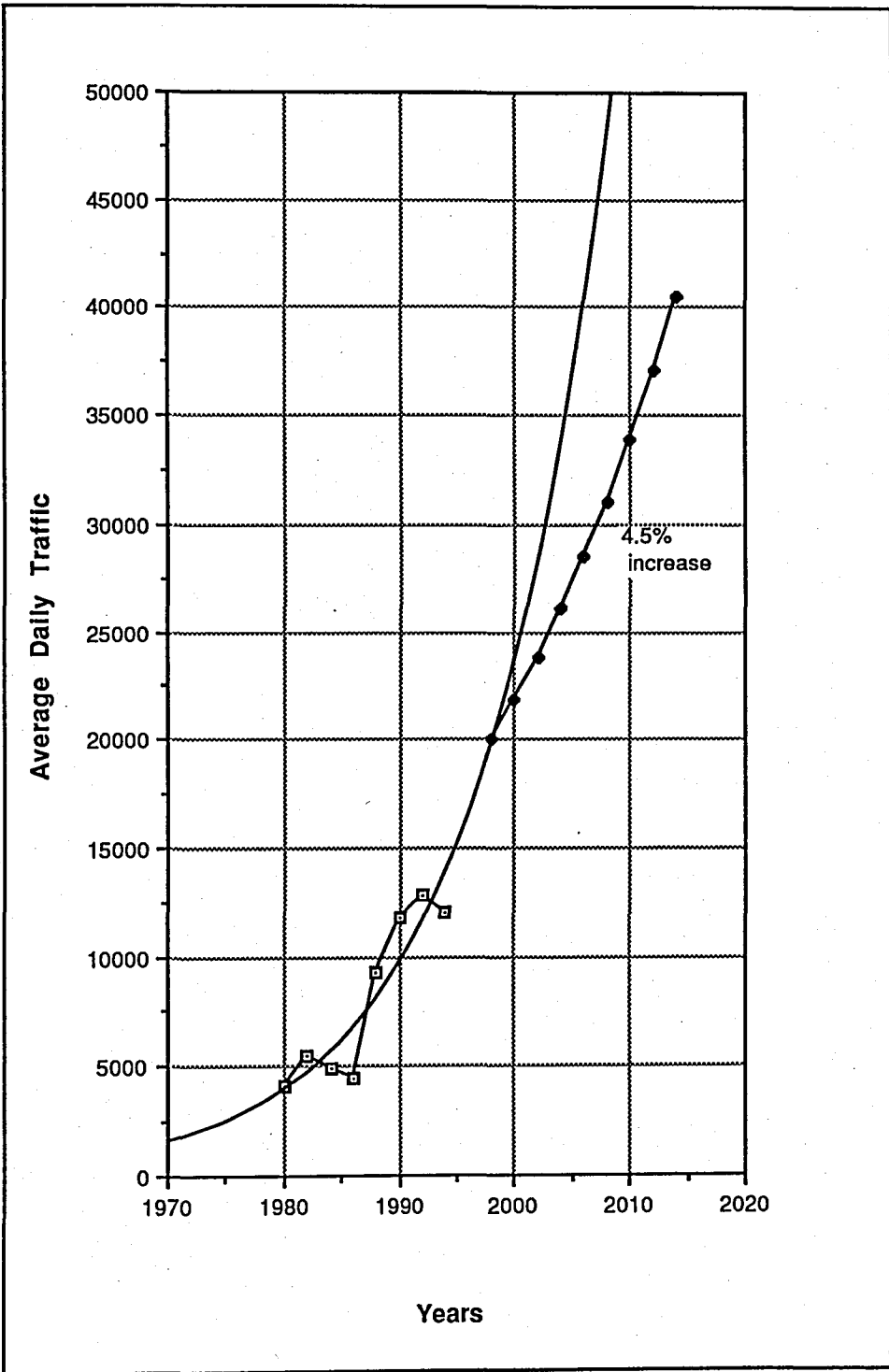

FIGURE 26.1. TRAFFIC FORECAST

TABLE 26.5. FORECAST OF AVERAGE DAILY TRAFFIC

| YEAR | VEHICLE | YEAR | VEHICLE |
|------|---------|------|---------|
| 1998 | 20000   | 2006 | 28442   |
| 1999 | 20900   | 2007 | 29712   |
| 2000 | 21840   | 2008 | 31059   |
| 2001 | 22823   | 2009 | 32447   |
| 2002 | 23850   | 2010 | 33918   |
| 2003 | 24924   | 2011 | 35444   |
| 2004 | 26045   | 2012 | 37039   |
| 2005 | 27217   | 2013 | 38706   |
|      |         | 2014 | 40447   |

TABLE 26.6. LOAN PAYMENT SCHEDULE (USD 10<sup>3</sup>)

|             | Investment Period        |                          |                          |                          | Operation Period         |                          |
|-------------|--------------------------|--------------------------|--------------------------|--------------------------|--------------------------|--------------------------|
| Items       | 1995                     | 1996                     | 1997                     | 1998                     | 1999                     | 2000                     |
| Maintenance | -                        | -                        | -                        | -                        | 2000                     | 2000                     |
| Toll Fee    | -                        | -                        | -                        | -                        | 20900(365)15=<br>114 428 | 21840(365)15=<br>119 574 |
| Net Income  | -                        | -                        | -                        | -                        | 112 428                  | 117 574                  |
| Loan        | 235 000                  | 185 000                  | 140 000                  | 92 000                   | 771 844                  | 698 981                  |
| Cumulative  |                          | 249 100                  | 460 146                  | 636 155                  |                          |                          |
| Balance     | 235000                   | 434 100                  | 600 146                  | 728 155                  | 659 416                  | 581 407                  |
|             |                          |                          |                          |                          |                          |                          |
| Items       | 2001                     | 2002                     | 2003                     | 2004                     | 2005                     | 2006                     |
| Maintenance | 2000                     | 2000                     | 2000                     | 2000                     | 2000                     | 2000                     |
| Toll Fee    | 22823(365)15=<br>124 956 | 23850(365)15=<br>130 579 | 24924(365)15=<br>136 459 | 26045(365)15=<br>142 596 | 27217(365)15=<br>149 013 | 28442(365)15=<br>155 720 |
| Net Income  | 122 956                  | 128 579                  | 134 459                  | 140 596                  | 147 013                  | 153 720                  |
| Loan        | 614 171                  | 520 688                  | 415 636                  | 298 048                  | 166 899                  | 21 079                   |
| Cumulative  |                          |                          |                          |                          |                          |                          |
| Balance     | 491 215                  | 392 109                  | 281 177                  | 157 452                  | 19 886                   | (-132 641) excess        |

## 26.4. Conclusions

With today's ferry traffic the Izmit Bay is a significant barrier to traffic and trade. It can be stated that traffic across the Izmit Bay is primarily long distance traffic. Regional short-distance traffic is minimal. Traffic between the Marmara region and Ege Region in the form of commuters and goods transport is very lively.

The fixed link will reduce the barrier at the Izmit Bay but naturally it will not disappear as there will still be a toll charge for the crossing. The fixed link will thus contribute to strengthening and increase opportunities for social communication between the populations of the two parts of the country.

## 27. CONCLUSIONS

### 27.1. International Experience

Few countries have got up to know experience in the field of strait crossings through fixed links.

The list would include, apart from Japan and Norway, the leaders undoubtedly, the United State of America, the Netherlands, Canada, Belgium, Denmark, the United Kingdom, France and at the level of planning and feasibility studies, Italy and Spain.

Two different solutions have to be considered [10]:

(a) Mega Projects: with a national incidence and even with international projection (Chesapeake Bay Bridge & Tunnel, the Channel tunnel, etc.)

(b) Domestic Projects: They are important projects but, although they are often scoped into a global policy of mobility and communication, they provide solutions to regional and domestic demands and problems.

Up to now, experience has been mainly gained at the level of domestic projects for fixed link of strait crossings.

### 27.2. Elements for a Methodology to Follow for Strait Crossing Planning

The order in which the following items will be presented did not imply a priority arrangement. Furthermore, there are common matters between them and mutual interactions [10].

## **A. Study of Territory**

Here it is studied the interest to develop the strait crossing after considering a serie of key concepts. As a result of this study, it is possible to settle the convenience or not to build the strait crossing.

Study of emplacement: the different corridors have to be analyzed carefully not only from the technical point of view but from the global socioeconomic perspective (for example: population, density, demography, etc..)

During this phase development plans at the regional, national, and even international (for Mega Projects) level must be considered. To that purpose, it is basic to prepare two lists: the list of advantages, positive aspects, and the list of disadvantages, negative aspects.

It is essential to arrive, as much as possible, at a quantitative evaluation of each factor (ranging from 1 to 3 or from 1 to 5). Only in that way it will be possible to compare in an objective way the different alternatives, that will provide an aseptic diagnostic.

## **B. Selection of Alternatives**

Here the different possible solutions are scoped: bridges, tunnels, immersed tunnels, ferries, new concepts.

For each of these alternatives the benefits and drawbacks are considered and evaluated in a quantitative way. Between the important items to study for the adoption of the decision are, as example, the following:

- (a) Direct cost of the works to overcome;
- (b) Geology;
- (c) Deepness of the water;
- (d) Actual traffic demand;
- (e) Expected traffic demand.

The list of items should be as exhaustive and comprehensive as possible and the quantitative evaluation and the ponderation weights might be carefully studied. The resultant of this phase is the decision about the more suitable solution to be adopted.

## **C. Technical Solutions**

Here the state of art of strait crossings has to applied. In this phase it is crucial the know-how and experience acquired. The expertise quality will let to study in detail, in depth more properly, each solution with short range of unexpected matters.

For this study, it is very valuable the local experience due to the fact that a particular solution is more suitable under certain conditions related to the territory, to the skill in a particular technique, the organization and management of the works. Safety is a key premise and a priority for the selection of the technical solution.

As a result of this phase there is shown the technical feasibility for each alternative.

#### **D. Economy**

Here the analysis cost/benefits have to be carried out, taking into an account only the direct costs of the "civil engineering" solution but the generalized cost that implies the social costs and the environmental costs.

One important aspect is the way to finance these projects that imply high inversions. There are different modalities and, case by case, have to be studied: toll system (in function of the cargo), private-public convenience, etc.

The solution to be retained is not the cheapest one but that one that suits better the technical, social, environmental requirements.

As a result of this phase the economic and financial feasibility plan will be obtained.

#### **E. Environment and Aesthetics**

These items are essential and must be considered from the very beginning of the process. The environmental study has to be an integral study and a detailed one.

A balance is required: to define the environmental situation before the works and the environmental situation after. In the interim, unreversible negative impacts must be avoided or minimized. The solution should be in the way that the balance of environmental impacts would be minimized.

There are several "Axles of impacts": redistribution of population, space used by the infrastructure and by the service areas, reutilization of debris and excavated materials.

From the aesthetical point of view and, in connection with the environment, the landscape engineering has to be considered, the portal design in the case of tunnels, the drivers' perception with a convenient treatment of the transitions outside - inside - outside, design of lighting, lining, etc.

As a result, the studies in relation with the environment and the aesthetic will be available.

## **F. Social Considerations**

Public works play an important role to improve the quality of life and have an undoubtedly social purpose.

The project has to be exposed to public information for allegations, from the different bodies, societies and individuals.

After this process, the decision has to be adopted by the Body with competence on this subject after the discussion process; allegations will be evaluated and, even, the alternative could be modified under certain circumstances.

The fixed links for strait crossings promote the regional development and they are very useful and powerful elements for the promotion of areas and regions through the creation of infrastructures.

### **27.3. Development of Strait Crossings in Other Regions of the World**

Between the fundamental reasons to consider for the development of strait crossings may be listed the following:

- (a) as a solution for mobility and communication;
- (b) as a system to vertebrate the territory and overcome isolation;
- (c) as factor for regional development;
- (d) as a way for social integration;
- (e) as element to facilitate tourism, trade, etc.

We could focus several regions all over the world where strait crossing solutions would become reality in the coming decades, pointing out the potentialities of reinforcing these kind of solutions, mainly through fixed links and specially through subsea road tunnels.

From the reflections exposed throughout this work, the following conclusions could be outlined [10]:

- (a) The need to promote and develop strait crossing solutions in base to experience.
- (b) These works have an important implications and have to be considered in their whole dimensions and from all the aspects implied.
- (c) It is necessary an objective approach to strait crossing planning and evaluation, that means to settle a quantitative evaluation of the different alternatives.

(d) The environment and the aesthetics are key items and must be considered from the startpoint the process.

(e) Due to the fact of the potentiality of these works, the social implications become fundamental.

(f) From a global perspective, an active policy to reinforce all systems and modalities of strait crossings is a policy "win to win" where everybody gets a positive result.

(g) The purpose of this work is to present several ideas for discussion because the subject of a global methodology for strait crossing planning and evaluation requires a detailed and exhaustive study and research.

# APPENDIX 1

## A1. LOADS ON BRIDGES

### A1.1. Dead Loads

The dead load of a highway bridge consists of the weight of the structure plus any equipment that is attached to the structure. A paradox of structural design is that the true dead load of the structure can not be determined until the bridge is designed and a final design cannot be accomplished unless the true dead load is known. It is therefore necessary to make a preliminary estimate of the dead load and then perform the design based on the estimated value. The weight of the structure can then be calculated and compared with the previously estimated weight [5].

The two weights most likely will not agree. It is then necessary to perform a second cycle of design based on the new dead load. If there has been any change in sizes of members, at the completion of this second cycle, the dead load is again calculated. This process of design refinement is repeated until the designer is sure that the final design calculations of the structure utilize the "as-built" weight of the bridge. A study of similar bridges is a good means of obtaining preliminary dead-load estimates.

The distribution of the dead load is a significant factor in the design of bridges. In most instances the dead load is assumed to be uniformly distributed along the length of a structural element, such as a slab, beam or a truss. Continuous bridges may have main load-carrying elements of varying depth. Considering the weight as uniformly distributed for such nonprismatic bridges may lead to some error, but it is usually negligible. Any error would generally be on the side of the safety.

## A1.2. Live Loads

Highway bridges should be designed to safely support all vehicles that might pass over them during the life of the structure. It is not possible for the designer to know what vehicles will use the structure or what the required life of the bridge will be.

To ensure the safety of the structure, some form of control must be maintained so that the designer has to provide sufficient strength in the structure to carry present and future predicted loads.

The regulation of vehicles using the bridge has to be such that excessive weight vehicles are prohibited from crossing the structure. Design control is provided in the United States by AASHTO, which specifies the design live load, and traffic regulation is provided by state laws regulating the weights of motor vehicles [5].

The present design vehicles contained in the AASHTO Specifications were adopted in 1944. The loadings consist of five weight classes, namely: H10, H15, H20, HS15, and HS20. The design vehicles for each of the five classes are shown in *Figure A1.1*. These vehicles were not selected to resemble any particular vehicle in existence, but are hypothetical. Any actual vehicle that would be permitted to cross a bridge should not produce stresses greater than those caused by the hypothetical vehicle.

The lighter loads, H10 and H15, are used for the design of lightly traveled state roads while the H20 and HS20 are used for national highways. The HS20 is used for the design of bridges on the Interstate Highway System. An additional alternate loading was instituted for this system. This loading consists of two axles spaced at 4 feet. and weighing 24 kips each (*Figure A1.1.*)

The HS truck loadings show a variable spacing of the two rear axles from 14 to 30 feet. The correct spacing is the length that produces the maximum effect. For stresses in simple span bridges, this spacing is the minimum value of 14 feet. However, for continuous spans a spacing greater than 14 feet may produce the maximum effect. The influence diagram indicates the proper spacing of the axles for maximum stresses.

In addition to the truck loadings, the Specifications contain equivalent loadings shown in *Figure A1.2* to be used in place of the truck loadings when they produce a greater stress than the truck. Prior to the 1944 Specifications, the design live load consisted of the basic *H* trucks preceded and followed by a train of trucks weighing three-quarters as much as the basic truck. In 1944 the HS truck was developed and the equivalent lane loading took the place of the train of trucks. Presently only *one* truck is to be used per lane per span.

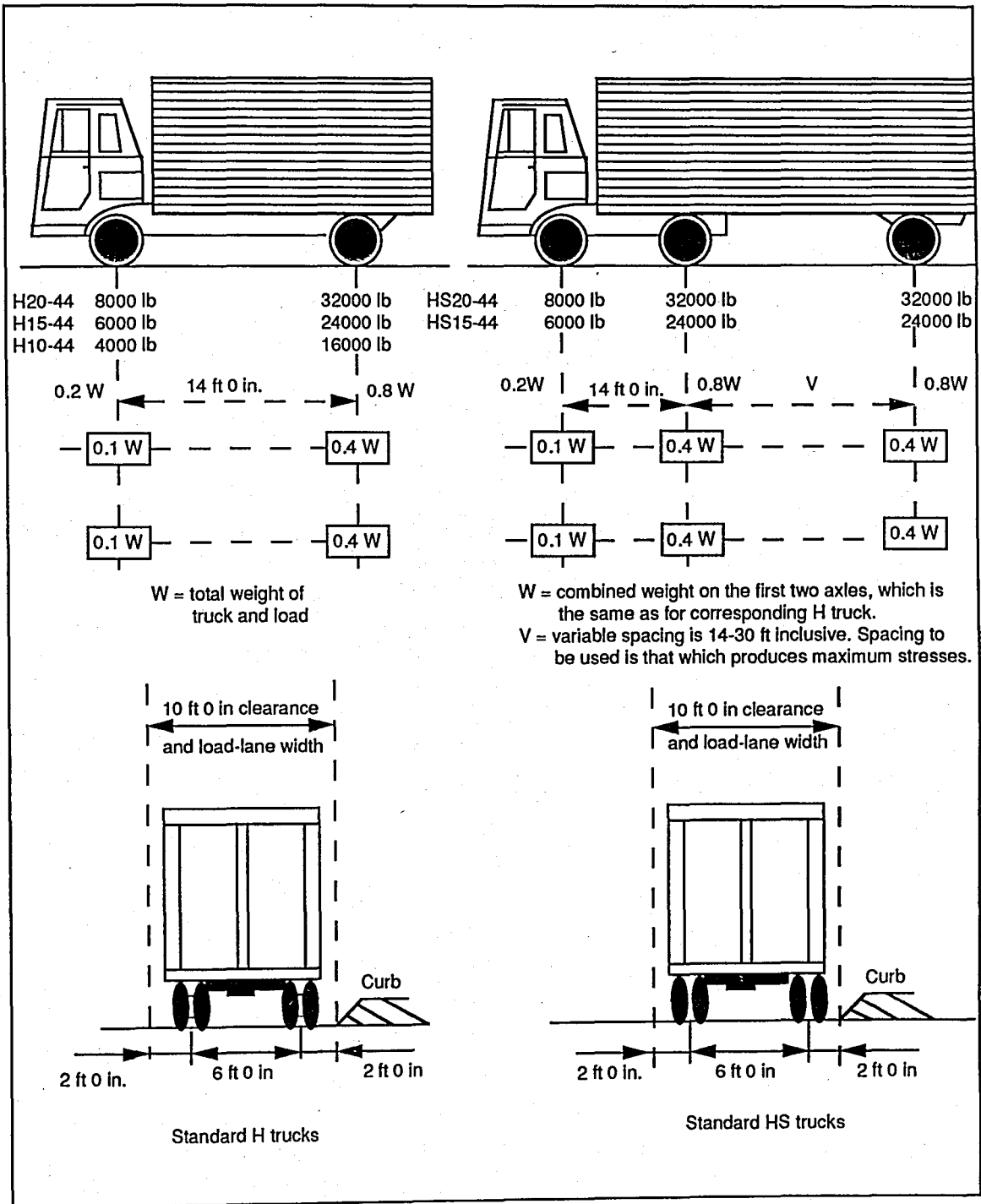

FIGURE A1.1. AASHTO DESIGN VEHICLE LOADINGS

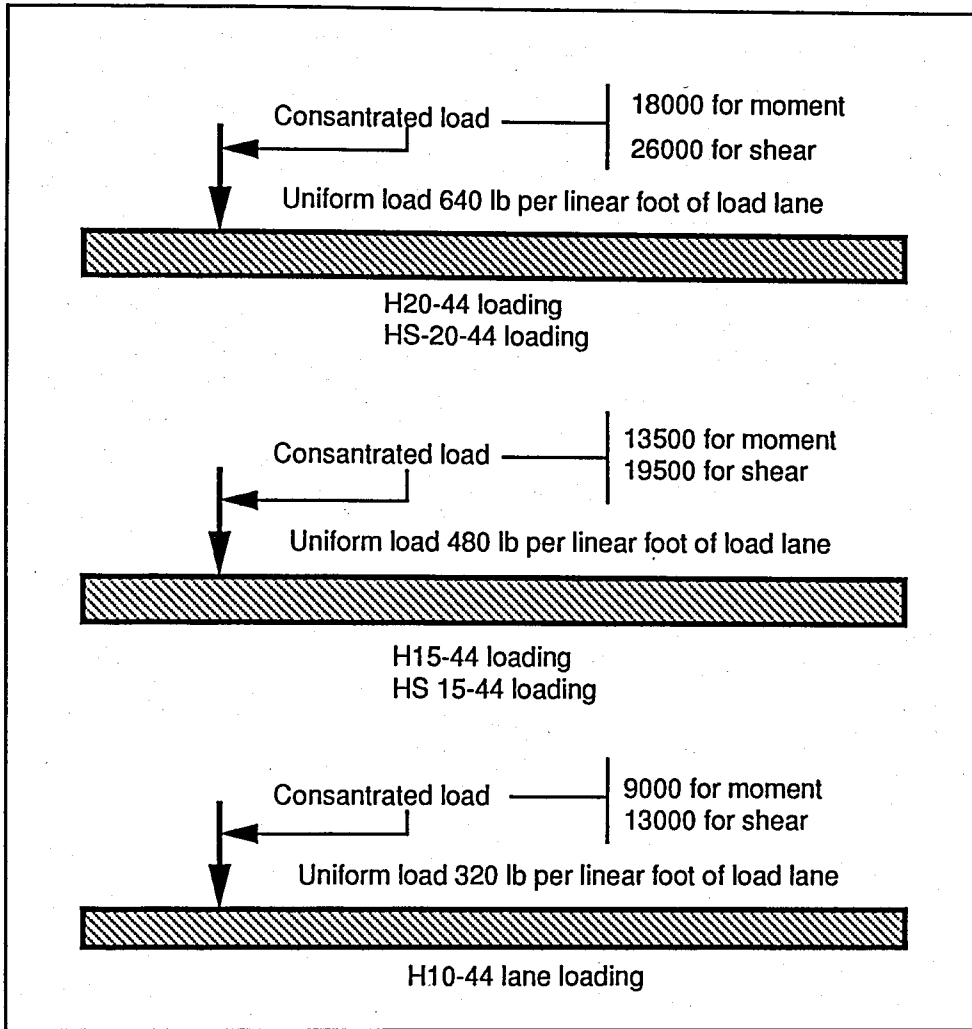

FIGURE A1.2. AASHTO DESIGN LANE LOADINGS

The concentrated load used in the equivalent lane loadings is different for moment than for shear. Only one concentrated load is used in a simple span or for a positive moment in continuous spans. Two concentrated loads are used for a negative moment. The equivalent lane load is placed so as to produce the maximum stresses. The uniformly distributed load can be divided into segments when applied to continuous spans. Both the concentrated load and the uniform load are distributed over a 10-ft lane width on a line normal to the centerline of the lane.

Although the AASHTO Bridge Design Specifications was prepared for use in the United States, all or parts of the specification have been adopted by other countries.

Design vehicles for any country should be selected very carefully. Bridges should not be damaged as a result of normal traffic or an occasional single overload, nor should they become obsolete in a few years because of heavier vehicles on the highways. In a like manner, the design vehicle should not be more severe than the heaviest vehicles that will use the structure during its lifetime. Such a situation is wasteful of the resources of a country. Mature engineering judgment is needed in the selection of proper design loadings.

Studies have been conducted in the United States to determine proper highway loadings, and additional studies are presently in progress. If the span is long, the actual live loading consists of a train of vehicles of various lengths and weights. The presence of a single heavy vehicle is of less importance than the loading spectrum over the entire span. For design purposes a train of vehicles can be equated to an equivalent uniform lane load. The proper equivalent uniform lane load can only be determined after extensive studies have been conducted on weight and spacing of actual vehicles since the highways or those that may use the bridge during its lifetime.

The AASHTO Specifications permits a reduction to 0.90 of total load when a bridge is designed for three lanes and a reduction to 0.75 of total load when four or more lanes are loaded.

### **A1.3. Dynamic Effect of Vehicles**

It is well-known that a vehicle moving across a bridge at a normal rate of speed produces greater stresses than if the vehicle were in a static position on the structure. This increment in stress can be called the *dynamic effect*. The terminology for the dynamic effect among bridge designers and bridge design specifications is *impact*. This latter term is not scientifically correct, since it denotes one body striking another, which only takes place in a bridge when a wheel falls into a "chuck hole."

The total dynamic effect is a result not only of vehicle wheels striking deck imperfections, but also of the live load being applied to the structure in a very short period of time. It can be proven by simple calculations of the theory of dynamics that a load instantly applied to a beam causes stresses of twice the magnitude as when the same load is static on the beam. In actual load applications to highway bridges, the total live loading is never instantaneous, but is applied to the structure in a finite time period. The dynamic effect due to sudden loading is variable for all structural elements of a bridge.

In addition to the true impact effect and the sudden loading effect, there is also a third effect, which is caused by the vehicle vibrating on its springs. Uneven roadway surfaces contribute to this effect. The vibration of the vehicle on its springs induces vibrations in the structure. The magnitude of stresses is dependent on the relative masses of the vehicle and the bridge, the natural frequency of the structure, and the damping characteristics of the bridge.

#### **A1.4. Longitudinal Forces**

When vehicles brake or accelerate while on a bridge, longitudinal forces are transmitted from the wheels of the vehicle to the deck. The magnitude of the longitudinal force depends on the amount of acceleration or deceleration. The maximum longitudinal force results from a sudden braking of a vehicle. The magnitude of this force is dependent on the weight of the vehicle, the velocity of the vehicle at the instant of braking, and the time interval to come to a complete stop [5].

The AASHTO Specification provides for a longitudinal force of five per cent of the live load in all lanes carrying traffic headed in the same direction. The live load as specified is the equivalent uniform lane load plus the concentrated load for moment. For spans of less than 84 feet the total equivalent lane load weight is less than the weight of the HS20 truck. It appears that the AASHTO provision is low for short-span two-lane structures. For long-span multiple-lane structures, the AASHTO provision is more realistic.

The Specification provides for the center of gravity of the longitudinal force to be applied six feet above the roadway surfaces. The longitudinal force adds very little stress to any members of the superstructure but is important in the design of the bearings and substructure. An additional longitudinal force due to the friction on expansion bearings should be considered in the substructure design. This frictional force is selected after consideration of type of bearings and possible service maintenance.

## A1.5. Centrifugal Forces

When a body travels on curvilinear path, it produces a force perpendicular to the tangent of the path. This centrifugal force is to be applied six feet above the roadway surface. When the reinforced concrete slab or steel grid deck is keyed or attached to its supporting members, the deck can be assumed to resist this centrifugal force at six feet above the deck can produce vertical forces in the main supporting girder or trusses.

## A1.6. Wind Loads

Wind loads have been the concern of bridge design engineers for many years, but the determination of the effect on a bridge is very complex. The design wind loads as contained in specifications are approximate for any particular structure. The problem of wind loads for a particular structure is very complex because of the many variables that affect the wind force, such as size and shape of the bridge, probable angles of attack of the wind, shielding effects of terrain, and the velocity-time relationship of the wind.

The wind load is a dynamic force. A peak wind velocity may be reached in a short period of time interval or decay rapidly (gust.) If the time interval to reach peak pressure is equal to or greater than the natural frequency of the structure, the wind load can be treated for all practical purposes as a static load equal to the peak pressure. This is usually the condition for most bridges.

The AASHTO Specification gives basic wind forces for a velocity of 100 mph as girders and beams 50 psf. A minimum force of 300 lb/ft should be used on girder and beam spans. The unit pressure is to be applied to the total area of the structure as seen in elevation at an angle of  $90^\circ$  to the longitudinal axis of the structure [5].

An addition wind force is also contained in the Specifications. This is a wind force on the live load equal to 100 lb/ft applied six feet above the roadway. When this additional load is applied, only 30 per cent of the wind load given above is applied to the structure itself.

The above loadings are only the loadings applied to the structure. The above values of wind force are considered in the substructure design for occasions when the wind is perpendicular to the bridge but winds at other angles are considered also for skew (yaw) angles up to  $60^\circ$ . When the wind is at a skew, longitudinal forces of the structure should also be considered.

The AASHTO Specification also provides for consideration of a vertical overturning force of 20 psf on the deck and sidewalk area at the windward quarter points of these areas.

The wind forces discussed above are treated as static forces. This treatment is usually satisfactory when the structure is very rigid. However, for flexible structures, this procedure is not sufficient. Suspended structures require a more investigative procedure. A steady-state wind may set up an effect called "vortex shedding" if the structure has a long period of natural frequency and a minimum of natural damping.

The vortex shedding refers to the production of vortices as the wind passes around the structure producing pressures and suctions alternating on each side of the obstruction to the wind. This alternating direction of forces at a right angle to the wind causes the structure to vibrate in a direction perpendicular to the wind. If the period of shedding of vortices is the same as the natural period of the structure, large amplitudes of vibration, that are sufficiently large to damage the structure take place.

For stiff structures, the wind velocity would have to be greater than normal for resonance to occur. However, for flexible structures, resonance can occur at low wind velocities. The bridge designer should be aware of the vortex-shedding phenomenon, even though it is unlikely to occur in most bridges. Several members of truss bridges have vibrated in the wind as a result of vortex-shedding effects and repairs have been necessary.

### **A1.7. Earthquake Forces**

Until recently the effects of earthquakes on highway bridges were largely ignored or only given consideration with regard to the design of substructures. Superstructures most likely have adequate strength to resist any inertia force in the vertical or horizontal direction. However, in recent earthquakes in Alaska, southern California, and Guatemala, several bridges were destroyed. The failure was not caused by the collapse of any element of the superstructure, but rather by the superstructure shaking off the bearings and falling to the ground; the structural failure of piers; the tipping of piers as a result of large earth movements; or the loss strength of the soil under the substructure as a result of the vibrations induced in the ground [5].

In times of earthquakes, it is important that bridges remain in place so that critical disaster relief vehicles such as ambulances and fire trucks can function.

The effect of an earthquake on a structure depends on the elastic characteristics of the structure and the distribution of the weight. A rigorous analysis is complex and involves the application of structural dynamics. In addition, it is necessary to know the expected ground motion under the substructure.

The usual procedure is to greatly simplify the problem by considering that the earthquake produces lateral forces acting in any direction at the center of gravity of the structure and having a magnitude equal to a percentage of the weight of the structure or any part of the structure under consideration. These lateral loads are then treated as static loads.

In 1975 AASHTO published an Interim Specification that listed a new earthquake loading procedure. This new procedure is much more rigorous than the former. The earthquake force is still treated as an equivalent static force if the supporting members are approximately equal. This equivalent static force is treated as a horizontal force acting at the center of gravity of the structure.

A very important consideration in the design of bridges subjected to seismic action is the effect of water on piers during an earthquake. The forces due to towers submerged in water were studied at the University of California, Berkeley. This study showed that for the analysis of earthquake forces, an added mass, in addition to the weight of the pier, must be included.

This added mass depends on the ratio of column radius to water height. Its value can be considerable - as much as the mass of water displaced by the piers. A careful dynamic analysis should be made for bridge piers in active seismic areas, especially when the piers are submerged.

### **A1.8. Stream Flow Pressure**

Substructures constructed in a region of flowing water should be designed to withstand water pressure. Such pressure could cause the pier to slide or overturn. Of considerable concern is the scour around the bottom of the piers.

The design for every bridge over a stream should involve the careful study of possible stream velocities. Almost all major streams in developed countries have flow records from which velocities can be obtained. If such information is lacking, the engineer must make the best estimate possible using whatever data are available.

### **A1.9. Floating Ice Pressure**

In cold climates floating ice can cause very high forces against piers. Bridges have been completely demolished from the pressure of floating ice [5].

The AASHTO Specification suggests a pressure of 400 lb / in<sup>2</sup> of contact area of ice and substructure. The thickness of ice and its point of application on the piers should be determined by the engineer after as complete an investigation as possible.

The value of 400 psi is based on an estimated crushing pressure of ice of this value. Higher values for the crushing strength of ice have been determined for low temperatures. A crushing strength of over 800 lb / in<sup>2</sup> has been recorded for ice at 2<sup>o</sup>F. A study of ice pressures against dams due to a rise in temperature - the condition producing the greatest pressure - has led to the conclusion that the 400 psi is an overly severe loading for dams. However, the condition for an expanding ice sheet behind a dam is quite different from floating ice being forced against a bridge pier by flow of water and possible wind drag on the ice. Very little is known with regard to these factors and until more information is forthcoming, the engineer should use the generally accepted value of 400 psi.

### **A1.10. Miscellaneous**

There are additional forces that may be applied to some types of structures under particular conditions. Such forces are caused by temperature changes, shrinkage, elastic shortening, and earth pressures. For quantitative values of these items, the engineer should consult the Specifications or make a judgment based on a study of the particular conditions.

## APPENDIX 2

# A2. HISTORICAL AND AESTHETIC PARAMETERS IN STRAIT CROSSINGS' EVALUATION

### A2.1. Introduction

History, Aesthetic and Nature are key columns where every behavior in civil engineering that want to be consistent in itself finds its support and consolidates on its function, purpose and environment [52].

A work of civil engineering as public work with an objective of public service and durability, has to be created, projected and built attending to considerations not only functional but also aesthetics due to the fact that these works are a common heritage of the society.

Several big projects have fixed landmarks in history meaning qualitative advances in this field; its temporal gestation sometimes has been very slow: For instance, the Channel tunnel with nearly two hundred years from the Methieu's initial idea up to now.

Japan and Norway are two countries that have wonder the rest of the world due, not only to projects, but also to real facts in the field of strait crossings. Several other countries have followed the route shown by the before mentioned ones and now, the study of fixed links has been generalized all over the world leaving the period in which it was an exceptional type of project.

## A2.2. Framework

When an analysis of the social, economic and environmental effects in relation with strait crossings is overcome, it is necessary to consider two components:

- (a) The historical perspective that deals with the temporal evaluation of the different possible solutions settled throughout decades in function of the existing contour conditions on each place.
- (b) The aesthetic and environmental considerations, in close relationship with an economic evaluation, that computes not only the specific costs of the civil works but the generalized cost, that extends to the evaluation of the environmental impacts, the insertion of the work in the landscape, the visual and acoustic incidence and also the aesthetic attention in close relation with the functionality of the structure.

Traditionally, the functional aspects have received great consideration; historically, the constructive aspects have always been very important; on the other hand, the economic aspects have been exaggerated by comparing the different budgets of the proposed solutions. Unfortunately, it is a common practice to choose the most strictly economical one without taking into account these three other more subtle and less obvious factors which are: aesthetic, history and nature.

## A2.3. Main Characteristic Items

When considering the analysis of a possible strait crossing, in a evaluation of the social, economic and environmental effects, several important aspects have to be scooped , into those parameters historical and aesthetic from its global acceptance. several of these items are listed, not in an exhaustive way, below and are briefly going to be commended with global traces.

Historical/Social parameters are as follows [52]:

- (a) knowledge of the history of strait crossings;
- (b) evaluation of historical links;
- (c) evaluation of political conditions;
- (d) the infrastructure as link of union;
- (e) activity gap between both sides of territory;
- (f) cultural peculiarities between both sides;
- (g) existing demand of transportation in that route;

- (h) strategic aspects;
- (i) security aspects;
- (j) trade communication;
- (k) the link as a patrimony of the collectivity;
- (l) progress in innovative process;
- (m) reduction in generalized cost of transportation.

Aesthetical/ Environmental parameters are as follows:

- (a) knowledge of the aesthetics in civil engineering
- (b) aesthetics form and communication;
- (c) direct landscape impact of the works
- (d) environmental design;
- (e) engineering design;
- (f) the strait crossing and the surroundings
- (g) balance between shape and function;
- (h) transitions to the strait crossings;
- (i) influence areas;
- (j) internal perspective;
- (k) external perspective;
- (l) balance of diverse possible solutions;
- (m) flexibility;
- (n) specific characteristics.

When a Multicriteria Analysis is applied we mention that it is absolutely essential to consider the parameters in relation with History and Aesthetic, not always easy to evaluate in quantitative way, but qualitative, but susceptible to be desegregated in many different aspects as those included in above that can be estimated with objective criteria.

When considering the diverse options for a fixed link, there is a first decision to be taken: above ground or underground? Here we could redefine the words of Santiago Amon when he wrote: "The city is sustained and defined between the scale and the excavate" for these ones: "The links of union may be supported through the air or through the earth."

## **A. History**

Paying attention first to the items into the historical perspective, the initial obliged reference point is to possess a base of knowledge about the history of the world wide strait crossings, having all that information processed in a rational way, arranged with respect to a number of key elements and questions that will let to compare and extrapolate one situation with another and take advice from experiences already developed.

The following step would be to study in a specific way the historical, the political and sociological characteristics in the parts to be linked through a strait crossing.

## B. Aesthetics

As Plato said "love of beauty was the cause of everything good that existed on earth and in heaven." Aesthetic, form of communication: One characteristic of this historical period is that everything seems to be "communicable," everything can be made to be close and available: time and space, distance; as Eugenio Trias says: "We must think in communication as that which determines and decides us, or that which constitutes our destiny." The question would be: Where are the limits? Are them, may be, ethic and aesthetics? There is one of the main problems of formal design: Aesthetics is the watchful and lucid consciousness of this radical un-availability of "the beautiful."

Tunnels versus bridge or vice versa: We would resort to bridges as paradigmatic form and question of all human construction but we should consider the tunnel as that artwork more in touch with earth and nature.

### A2.4. Practical Examples

From Semiramis tunnel under the Euphrate to the Japan/Korea tunnel construction as part of the international highway project, there are series of references of strait crossings throughout history that we are going to evoke as highlights in a long and exciting history.

The ancient examples are sometimes good examples to learn about the efforts to overcome obstacles; this is not a recent achievement; now the advance of technology, the easy way to share experiences in the art of tunneling all over the world are powerful motors to impulse solutions regarded some decades ago as science-fiction and now as a reality.

*Table A2.1* shows a brief list of important fixed links. There have been included passes through rivers as elemental/not so elemental cases of strait crossings [52].

But if we go 4200 years back in time to Babylon, we find that Semiramis or perhaps another mythical queen built two structures, as Herodotus, Diodorus and Strabo refer, to cross the Eufrate, one bridge and one tunnel; they connected both banks of the city's river, the established a fixed link between the initial strait that is the river, the water that irrigates and also that represents a barrier for communication, and also we find in this example a transcendental purpose, the link between the politics and the religion, the passage way were settled between the palace and the temple.

TABLE A2.1. LIST OF IMPORTANT FIXED LINKS

| YEAR      | TUNNEL (t) / BRIDGE (b)        |
|-----------|--------------------------------|
| 2230 b.C. | Semiramis t. Euphrate, Babylon |
| 2230 b.C. | Semiramis b. Euphrate, Babylon |
| 1843 a.D. | Brunel t. Thames               |
| 1868      | Washington St. t. Chicago      |
| 1871      | LaSalle St. t. Chicago         |
| 1886      | Severn railway t.              |
| 1886      | Mersey railway t.              |
| 1934      | Mersey road t.                 |
| 1942      | Kanmon railway t.              |
| 1958      | Kanmon road t.                 |
| 1973      | Shin Kanmon railway t.         |
| --        | The Chesapeake bay area t./b.  |
| 1982      | Verdo road t.                  |
| 1986      | Seikan railway t.              |
| 1987      | Ellingsoy road t.              |
| 1987      | Valderoy road t.               |
| 1987      | Giske road t.                  |
| 1990      | Godoy road t.                  |
| --        | Honshu-Shikoku b. link         |
| --        | The Faro b. link               |
| --        | Kristiansung t. link           |
| --        | Escandinavian Great Belt link  |
| --        | Channel t.                     |
| --        | Messina strait b.              |
| --        | Trans-Tokio Bay Highway        |
| --        | Gibraltar fixed link           |
| --        | Japan-Korea t.                 |

If we advance in from that point, about four thousand years, we find the second tunnel in history under a river bed; of course everybody knows that we are referring to Brunel's tunnel under the Thames; the most famous tunnel in history with so many failed attempts, such high cost in human lives and so many battles between brave men and floodings, established a fixed link between those two London.

But a fixed link has a relevant strategic goal. Here the tunnel has revealed from history to be a good solution. We find an early example in the XIX th century, when the Chicago Fire in 1871 it became a convenient yardstick to measure other disasters; two tunnels, the Washington St. and LaSalle St. were the only two links of union with survival; we must remember that the existing wooden bridges were easy food for flames.

The Norwegian experience in the field of subsea tunnels is excellent, starting with Vardo subsea tunnel and afterwards the series of three subsea road tunnels, and one bridge, in Alesund area and several other examples following a systematically trend to cross straits or fjords with tunnels or bridges, getting a spectacular improvement on mobility and communication throughout Norway. In this example, a complex geography has found solutions through effort and talent.

Into the complex network of communication links, roads and railways mainly, at an international level, there have remained several points with special difficulties to cross; these are the mountains ranges, the straits and rivers and even the conurbations; usually the problems are not exclusively in the technical field, where at the turn of the century the advances have been amazing, but also we find another kind of obstacles apart from the strait itself; we refer to historical, cultural and political differences between two sides of the same world but sometimes of different countries.

## **A2.5. Conclusions**

Nowadays we know that if contempt for the function leads to unacceptable exaggerations and waste, contempt for nature, history, beauty and culture leads to the destruction of art and life. The dichotomy between utility and beauty means nothing but our inability to satisfy what everyone demands: work and beauty, utility and beauty. In a more just and human society people should not be obliged to choose between the two of them.

# APPENDIX 3

## A3. RECORDS OF COLLISION ACCIDENTS IN THE PERIOD 1960-1991

### 1960 Severn River Railway Crossing, England

Vessel : Tug pulling two barges each 450 tones displacement  
Accident : Broadside collision with pier  
Damage : Two spans and one supporting pier collapsed causing five fatalities  
Cause : Tug pilot's negligence in dense fog

### 1964 Maracibo Lake, Venezuela

Vessel : 36,000 DWT loaded tanker  
Accident : Broadside collision with two piers more than 600m from the navigational spans  
Damage : Two spans and one supporting pier collapsed causing five fatalities  
Cause : Tug pilot's negligence in dense fog

### 1964 Pontchartrain Lake, Louisiana, USA

Vessel : Tug towing two loaded barges  
Accident : Three trestles were struck by the tug and the two barges  
Damage : Four spans collapsed, causing six fatalities  
Cause : Helmsman's lack of attention

### 1964 Pontchartrain Lake, Louisiana, USA

Vessel : Tug towing two barges  
Accident : Tug hit a pile bent  
Damage : One pilot bent was destroyed and two spans collapsed  
Cause : Tug pilot's inattention (possibly asleep)

**1967 Chesapeake Bay, Virginia, USA**

Vessel : Drifting coal barge  
Accident : Vessel thrown repeatedly against the bridge deck  
Damage : Six spans were seriously damaged  
Cause : Barge torn loose from moorings in storm

**1970 Chesapeake Bay, Virginia, USA**

Vessel : 10,000 DWT US-navy cargo ship  
Accident : 1 hour battering against the bridge  
Damage : Five spans knocked down and 11 other spans damaged  
Cause : Vessel torn loose in stormy weather

**1972 Chesapeake Bay, Virginia, USA**

Vessel : Drifting barge  
Accident : Barge thrown repeatedly against the bridge deck  
Damage : Two spans partially collapsed and five other spans were damaged  
Cause : Towline to tug broken in heavy wind

**1972 Brunswick River, Georgia, USA**

Vessel : 13,000 DWT freighter  
Accident : The superstructure hit by the bow of the ship  
Damage : Three spans collapsed, causing teen fatalities  
Cause : The helmsman misunderstood the pilot's instructions

**1974 Pontchartrain Lake, Louisiana, USA**

Vessel : Tug pulling four empty barges  
Accident : Tug hit pier some way from navigation span  
Damage : Two pile bents were damaged and three spans collapsed, causing three fatalities  
Cause : Tug pilot asleep

**1974 Welland Canal, Ontario, Canada**

Vessel : Ore carrier (length: 204 meters)  
Accident : Ship rammed lifting span while opening  
Damage : Lift span fell in canal and lift towers were damaged  
Cause : Unknown

**1975 Derwent River, Hobart, Tasmania, Australia**

Vessel : 7,200 DWT bulk carrier  
 Accident : Head-on and broadside collision with two piers  
 Damage : Three spans were collapsed, causing 15 fatalities  
 Cause : Loss of steering ability due to engine failure

**1975 Fraser River, New Westminster, British Columbia, Canada**

Vessel : Barge in ballast (length: 183 meters)  
 Accident : Barge hit the bridge superstructure  
 Damage : One 120 meters span collapsed  
 Cause : Barge tore loose from mooring in heavy rainstorm

**1976 Pass Manchac Channel, Louisiana, USA**

Vessel : Barge towed by a tug  
 Accident : Barge hit a pile bent  
 Damage : Pile bent destroyed and three spans collapsed, causing at least one fatality  
 Cause : Barge off course due to careless navigation

**1977 James River, Hopewell, Virginia, USA**

Vessel : 25,000 DWT tanker in ballast  
 Accident : The stem of the ship destroyed a pier bent about 120 meters from the navigational span centerline  
 Damage : Two spans collapsed  
 Cause : Electrical fault in steering gear

**1977 Passaic River, Union Avenue, New Jersey, USA**

Vessel : Empty oil barge  
 Accident : Collision with a pier  
 Damage : Two spans collapsed  
 Cause : Broken towline to tug

**1977 Gothenburg Harbour, Tingstad, Sweden**

Vessel : 1600 DWT gas tanker in ballast  
 Accident : Ship hit approach spans  
 Damage : Two approach spans destroyed  
 Cause : Electrical fault in steering gear

**1978 Berwick Bay, Southern Pacific Railroad, Louisiana, USA**

Vessel : Tug pushing four barges  
Accident : Lead barge hit the side span bridge superstructure  
Damage : One 70 meters steel span fell into water and sank  
Cause : Tug skipper navigating with under powered tow

**1979 Second Narrows Railway Crossing, Vancouver, Canada**

Vessel : 22,000 DWT bulk carrier  
Accident : Stem of ship struck the superstructure in the side span about 100 meters from the navigational span centerline  
Damage : One span collapsed  
Cause : Captain's misjudgment of land marks due to dense fog

**1980 Tjörn, Almö Sound, Sweden**

Vessel : 27,000 DWT product carrier in ballast  
Accident : Deck house of ship struck the arch structure near the foundation on shore, about 100 meters from the navigation channel centerline  
Damage : Total collapse of the main span causing eight fatalities  
Cause : Steering difficulties in rough weather and dense fog due to reduced engine power

**1980 Tampa Bay, Sunshine Skyway, Florida, USA**

Vessel : 35,000 DWT bulk carrier in ballast  
Accident : Stem of ship struck bridge column above pier top about 250 meters from navigation channel  
Damage : Three spans collapsed, causing 35 fatalities  
Cause : Pilot's careless navigation in rough weather with reduced visibility

**1981 Narragansett Bay, Newport, Rhode Island, USA**

Vessel : 45,000 tones displacement tanker  
Accident : Ship struck main tower pier of suspension bridge head-on at 3 m/sec velocity  
Damage : Only superficial damage although the collision force substantially exceeded the design force  
Cause : Pilot's careless navigation in dense fog

**1982 Mosel River, Richemont Gas Pipeline, France**

- Vessel : Tug pushing two barges  
 Accident : Barge struck bridge pier  
 Damage : One pier was destroyed resulting in collapse of the gas pipeline causing seven fatalities  
 Cause : Tug pilot's careless navigation in dense fog

**1982 Mississippi River, Hannibal, Missouri, USA**

- Vessel : Tug pushing 15 barges  
 Accident : Barges struck abutment while passing swing span, lost control and tug swung into approach span  
 Damage : One approach span collapsed  
 Cause : Careless navigation

**1983 Sentosa Aerial Tramway, Singapore**

- Vessel : Petroleum dill ship with 69 meters high mast  
 Accident : Ship drifted into tramway and the mast severed the aerial cables of the tramway  
 Damage : Two tramway cars fell into harbor causing seven fatalities  
 Cause : Tow line failed when ship was warped out of berth by tug

**1983 Volga River Railway Crossing, Ulyanovsk, Russia**

- Vessel : Passenger vessel "Alexander Suwarow"  
 Accident : Vessel strayed off course and ran too close to the support column for the arch bridge and the upper deck of vessel collided with bridge superstructure  
 Damage : The deckhouse of the vessel, including a film hall, was torn off causing approximately 170 fatalities  
 Cause : Captain's careless navigation

**1990 Herbert C. Bonner Bridge, North Carolina, USA**

- Vessel : Hopper dredge "Northerly Isle" (length: 60 meters)  
 Accident : Vessel drifted into the superstructure of the bridge  
 Damage : 4 pile bents were demolished and five spans collapsed  
 Cause : The vessel dragged its anchors during a storm

**1990 Tosterö, Strangnas, Sweden**

- Vessel : Freighter "arosandra" (length: 60 meters)  
Accident : Vessel struck the swing span support pier and side span superstructure  
Damage : The pier was displaced and the bridge superstructure in side span was partly torn down  
Cause : Captain's careless navigation due to drunkenness

**1991 Carnafuli River, Chittagong, Burma**

- Vessel : Unknown  
Accident : Vessel drifted into the superstructure of the bridge  
Damage : One superstructure span torn down  
Cause : Vessel lost control due to cyclone

**1991 Hamburg Harbor, Kattwyk, Germany**

- Vessel : 21,450 tones freighter "Stanislaw Kulcznski"  
Accident : Freighter under tow by three tugs in dense fog lost control and crashed into the side span of the lift bridge  
Damage : The side span fell into the river and one of the lift towers was seriously damaged  
Cause : The vessel lost control due to loss of one of the three tow lines

## REFERENCES

1. Seim, C., "Case Studies of Long-Span Bridges for Strait Crossings," *Proceedings of the Second International Symposium on Strait Crossings, Trondheim-Norway, 10-13 June 1990*, pp. 99-102, Rotterdam, Brookfield, 1990.
2. Paterson, T. J. M., "The Potential for Undersea Road Tunnels in Scotland," *Proceedings of the Third International Symposium on Strait Crossings, Alesund-Norway, 12-15 June 1994*, pp. 769-776, Rotterdam, Brookfield, 1994.
3. Gimsing, N. J., *Cable Supported Bridges*, Toronto: John Wiley, 1983.
4. Troitsky, M. S., *Cable-Stayed Bridges*, London: William Clowes, 1977.
5. Heins, C. P. and D. A. Firmage, *Design of Modern Steel Highway Bridges*, Toronto: John Wiley, 1979.
6. Walter, P. and B.S. John, *Construction and Design of Cable-Stayed Bridges*, Toronto: John Wiley, 1986.
7. Lwin, M. M. and A. Grant, "The New Floating Bridge for Lake Washington, USA," *Proceedings of the Third International Symposium on Strait Crossings, Alesund-Norway, 12-15 June 1994*, pp. 721-728, Rotterdam, Brookfield, 1994.
8. Loken, A. E., Oftedal R. A. and J. V. Aarsnes, "Aspects of Hydrodynamic Loading and Response in Design of Floating Bridges," *Proceedings of the Second International Symposium on Strait Crossings, Trondheim-Norway, 10-13 June 1990*, pp. 479-486, Rotterdam, Brookfield, 1990.
9. Kristoffersen, K., Nielsen, S. G. and E. Loken, "Important Design and Safety Aspects for Tube and Tunnel Bridges," *Proceedings of the Second International Symposium on Strait Crossings, Trondheim-Norway, 10-13 June 1990*, pp. 543-549, Rotterdam, Brookfield, 1990.

10. Junca, J. A., "The Norwegian Experience on Strait Crossings: A Pattern and a Source of Knowledge," *Proceedings of the Third International Symposium on Strait Crossings*, Alesund-Norway, 12-15 June 1994, pp. 353-358, Rotterdam, Brookfield, 1994.
11. Nyhus, K. A., "The Vertically Tethered Bridge," *Proceedings of the Second International Symposium on Strait Crossings*, Trondheim-Norway, 10-13 June 1990, pp. 503-507, Rotterdam, Brookfield, 1990.
12. Dahle, L. A., Reed, K. and J. V. Aarsnes, "Model Tests With Submerged Floating Tube Bridges," *Proceedings of the Second International Symposium on Strait Crossings*, Trondheim-Norway, 10-13 June 1990, pp. 435-439, Rotterdam, Brookfield, 1990.
13. Larsen, O. D., *Ship Collision With Bridges: The interaction Between Vessel Traffic and Bridge Structure*, Zurich: International Association for Bridge and Structural Engineering (IABSE), 1993.
14. Hovland, S., Isaksen, T. and C. Hansuold, "Skarnsundet Cable-Stayed Bridge, Norway," *Proceedings of the Second International Symposium on Strait Crossings*, Trondheim-Norway, 10-13 June 1990, pp. 331-337, Rotterdam, Brookfield, 1990.
15. Melby, K., Hovland, S. and H. Ostlid, "Construction and Maintenance of Two Cable-Stayed Bridges in Adverse Environment," *Proceedings of the Third International Symposium on Strait Crossings*, Alesund-Norway, 12-15 June 1994, pp. 157-165, Rotterdam, Brookfield, 1994.
16. Jordet, E. A., Svensson, H. and W. B. Klaveness, "Helgeland Bridge: A Slender Concrete Cable-Stayed Bridge in a Location of Severe Winds," *Proceedings of the Second International Symposium on Strait Crossings*, Trondheim-Norway, 10-13 June 1990, pp. 325-329, Rotterdam, Brookfield, 1990.
17. Kawabata, A., Fukumoto, K. and T. Higuchi, "On the Akashi Kaikyo-World's Longest Suspension- Bridge," Tarumi Construction Office, Honshu-Shikoku Bridge Authority, 1992.

18. Morimoto, T., Kashima, S., Okada, R. and S. Hirano, "Construction of Akashi Kaikyo Bridge Foundations in the Strait," *Proceedings of the Second International Symposium on Strait Crossings*, Trondheim-Norway, 10-13 June 1990, pp. 371-378, Rotterdam, Brookfield, 1990.
19. Bakke, L. B., Hellesand, J. and A. Vangsnes, "Design and Construction of the Askoy Suspension Bridge," *Proceedings of the Third International Symposium on Strait Crossings*, Alesund-Norway, 12-15 June 1994, pp. 75-82, Rotterdam, Brookfield, 1994.
20. "The Askoy Bridge, 1990-1992," Monberg and Thorsen A/S, Copenhagen - Denmark, 1994.
21. Virlogeux, M., "The Normandie Bridge, France," *Structural Engineering International*, Vol. SEI-4, No. 4, pp. 208-213, November 1994.
22. Deroubaix, D., Demare, A. and R. Lavoue, "The Normandie Bridge," *Proceedings of the Third International Symposium on Strait Crossings*, Alesund-Norway, 12-15 June 1994, pp. 1-19, Rotterdam, Brookfield, 1994.
23. Grant, A. and M. Y. Lwin, "Service and Failure of the First Concrete Floating Bridge," *Proceedings of the Third International Symposium on Strait Crossings*, Alesund-Norway, 12-15 June 1994, pp. 715-719, Rotterdam, Brookfield, 1994.
24. Jordet, E., Kjekken, J. and T.A. Thorsen, "The Salhus High Level Bridge," *Proceedings of the Third International Symposium on Strait Crossings*, Alesund-Norway, 12-15 June 1994, pp. 217-222, Rotterdam, Brookfield, 1994.
25. Meass, P., Landet, E. and V. Vindoy, "Design of the Salhus Floating Bridge," *Proceedings of the Third International Symposium on Strait Crossings*, Alesund-Norway, 12-15 June 1994, pp. 729-734, Rotterdam, Brookfield, 1994.
26. The McGraw-Hill, "Box Girders Float Across a Fjord," *Construction Weekly, ENR*, March 1994.
27. Stabenfeldt, T., "The Salhus Bridge: Construction and Installation," *Proceedings of the Third International Symposium on Strait Crossings*, Alesund-Norway, 12-15 June 1994, pp. 543-546, Rotterdam, Brookfield, 1994.

28. Solland, G., Landet, E. and J. P. Transkar, "Use of High Strength Steel in Norwegian Floating Bridges," *Proceedings of the Third International Symposium on Strait Crossings*, Alesund-Norway, 12-15 June 1994, pp. 735-742, Rotterdam, Brookfield, 1994.
29. Solheim, A. and M. Skille, "Instrumentation for Verification of Design Criteria for the Bergsoysund and Salhus Floating Bridges," *Proceedings of the Third International Symposium on Strait Crossings*, Alesund-Norway, 12-15 June 1994, pp. 743-749, Rotterdam, Brookfield, 1994.
30. Molenaar, I. V. L. (editor), "Immersed and Floating Tunnels," International Tunneling Association, 1994.
31. Megaw, T. M., and J. V. Bortlett, *Tunnels*, London: John Wiley, 1982.
32. Romhild, C. J. and N. S. Rosmussen, "Submerged Structures Supported on Sand Pumped Underneath Structure," *Proceedings of the Third International Symposium on Strait Crossings*, Alesund-Norway, 12-15 June 1994, pp. 695-702, Rotterdam, Brookfield, 1994.
33. Culwerwell, D. R., "World List of Immersed Tubes," *Tunnels and Tunnelling*, pp. 53-58, March 1988.
34. Lancelloti, A. R. and L. G. Silano, "Available Methods for the Construction of Submerged Floating Immersed Tube Tunnels," *Proceedings of the Second International Symposium on Strait Crossings*, Trondheim-Norway, 10-13 June 1990, pp. 409-414, Rotterdam, Brookfield, 1990.
35. Toki, S., Nishikawa, J., Torijihara, M. and J. Sakimoto, "Experimental Research Related for the Behavior of an Ocean-Floor Foundation Pile Which Receives a Cyclic Pull-Out Force Due to Waves," *Proceedings of the Third International Symposium on Strait Crossings*, Alesund-Norway, 12-15 June 1994, pp. 751-758, Rotterdam, Brookfield, 1994.
36. Megaw, T. M., *Tunneling*, London: Thomas Telfard, 1982.

37. Molenaar, V. L., Groof, J. D. and P. V. Putte, "The Construction of the Liefkenshoek Tunnel in Belgium," *Proceedings of the Second International Symposium on Strait Crossings*, Trondheim-Norway, 10-13 June 1990, pp. 445-454, Rotterdam, Brookfield, 1990.
38. Hartwell, D., Kofoed, P. and W. Unterberger, "Great Belt Tunnel: Cross Passage Construction," *Proceedings of the Third International Symposium on Strait Crossings*, Alesund-Norway, 12-15 June 1994, pp. 327-334, Rotterdam, Brookfield, 1994.
39. Presius, P., Bennick, K., Hartley, I. F. and A. P. Deane, "Great Belt Link - Civil Works Design for the Eastern Railway Tunnel," *Proceedings of the Second International Symposium on Strait Crossings*, Trondheim-Norway, 10-13 June 1990, pp. 185-191, Rotterdam, Brookfield, 1990.
40. Eskesen, S. D. and S. C. Richards, "Storebaelt Eastern Railway Tunnel Designers Review of Construction Works," *Proceedings of the Third International Symposium on Strait Crossings*, Alesund-Norway, 12-15 June 1994, pp. 319-326, Rotterdam, Brookfield, 1994.
41. Smordal, O. and A. Grovdal, "Ferry Operation in More and Romsdal County, Norway," *Proceedings of the Third International Symposium on Strait Crossings*, Alesund-Norway, 12-15 June 1994, pp. 833-839, Rotterdam, Brookfield, 1994.
42. Wahl, J. E., "Ferries - A Logical, but often Neglected Aternative," *Proceedings of the Second International Symposium on Strait Crossings*, Trondheim-Norway, 10-13 June 1990, pp. 185-191, Rotterdam, Brookfield, 1990.
43. Nordal, H., "High Speed Light Craft, an Alternative Mode of Strait Crossings," *Proceedings of the Third International Symposium on Strait Crossings*, Alesund-Norway, 12-15 June 1994, pp. 847-851, Rotterdam, Brookfield, 1994.
44. "Şehir Hatları, Yolcu ve Araç Sayıları Geçiş Ücretleri-1989-1993," Türkiye Deniz İşletmeleri, Karaköy - İstanbul, 1994.
45. "Prequalification Document for Izmit Bay Crossing," The General Directorate of Highways (KGM), Ankara, 1994.

46. Brevninger, P., "Planning a Fixed Link for the Fahmarn Belt by Private Enterprise," *Proceedings of the Third International Symposium on Strait Crossings, Alesund-Norway, 12-15 June 1994*, pp. 847-851, Rotterdam, Brookfield, 1994.
47. Bogen, K., "An Electronic Identification and Registration Systems for Non Stop Tolling Applications (Q-Free)," *Proceedings of the Second International Symposium on Strait Crossings, Trondheim-Norway, 10-13 June 1990*, pp. 583-587, Rotterdam, Brookfield, 1990.
48. Seifried, G., "Rion-Antirion Strait Crossing," *Proceedings of the Second International Symposium on Strait Crossings, Trondheim-Norway, 10-13 June 1990*, pp. 319-323, Rotterdam, Brookfield, 1990.
49. Malkatas, N. E., "The Rion-Antirion Bridge Crossing in Greece," *Proceedings of the Second International Symposium on Strait Crossings, Trondheim-Norway, 10-13 June 1990*, pp. 645-651, Rotterdam, Brookfield, 1990.
50. Tolstrup, C., Ostenfeld, K. H., Jacobsen, A. S., Petersen, A. and D. Olsen, "Great Belt Link - Outline Design and Special Studies for the East Bridge," *Proceedings of the Second International Symposium on Strait Crossings, Trondheim-Norway, 10-13 June 1990*, pp. 297-304, Rotterdam, Brookfield, 1990.
51. Tezcan, S. S. and E. Arıođlu, "Chanakkale Ataturk Bridge," *Proceedings of the Third International Symposium on Strait Crossings, Alesund-Norway, 12-15 June 1994*, pp. 21-35, Rotterdam, Brookfield, 1994.
52. Junca, J. A., "Historical and Aesthetic Parameters in Strait Crossings' Evaluation," *Proceedings of the Second International Symposium on Strait Crossings, Trondheim-Norway, 10-13 June 1990*, pp. 43-46, Rotterdam, Brookfield, 1990.