

FOR REFERENCE

101 031

**USE OF PRECAST AND PRESTRESSED
HOLLOW CORE SLABS
IN CONSTRUCTION INDUSTRY**

by

Y. Zahit Gündoğdu

B.S. in C.E., University of Yıldız , 1985

Submitted to the Institute for Graduate Studies in
Science and Engineering in partial fulfillment of
the requirements for the degree of
Master of Science
in
Civil Engineering

Bogazici University Library



39001100312464

14

Boğaziçi University

1988

ACKNOWLEDGEMENT

I would like to express my sincere gratitude to my thesis supervisor Prof. Dr. Semih S. TEZCAN, for providing continual assistance and inspiration on this subject and for his invaluable guidance, and support throughout the study.

My special thanks are also due to Dr. Ersin ARIÖĐLU, Chairman of Yapı Merkezi, for the supply of necessary data and technical details about the precast hollow slab and wall elements.

I also feel gratitude to the research engineers Mr. George STAMP and Faruk YANIK for their valuable help and constructive criticism during the preparation of the thesis.

Y. Zahit GÜNDOĐDU

İstanbul, May 1988

USE OF PRECAST AND PRESTRESSED HOLLOW CORE SLABS IN CONSTRUCTION INDUSTRY

A B S T R A C T

Physical and technical characteristics as well as the design procedures of the prestressed precast hollow core slab and wall elements are studied. It is intended to present for the convenience of practicing engineers, a general guideline and comprehensive information about the hollow core slabs and walls used in both residential and commercial buildings.

After a brief introduction to the precast and prestressed structures, physical and technical characteristics such as thermal insulation, acoustical parameters, fire resistance, manufacturing methods and advantages of prestressed hollow core slab elements are described.

Subsequently, after the load carrying characteristics of these elements are emphasized, the connection details are illustrated with their design calculation techniques. In addition, analysis and design of hollow core slab elements under the horizontal and vertical loads are discussed. The design procedures are presented together with numerical examples in accordance with the ACI 318-83 and TS 3233 codes. Furthermore, special design considerations are also explained with numerical illustrations.

Finally, the basic advantages of the use of these prestressed prefabricated elements in housing construction are summarized.

PREKAST VE ÖNGERİLMELİ BOŞLUKLU DÖŞEME ELEMANLARININ İNŞAAT ENDÜSTRİSİNDE KULLANIMI

Ö Z E T

Konut ve ticari yapılarda kullanılmakta olan öngerilmeli boşluklu döşeme elemanlarının dizayn prosedürleri geniş bir şekilde ele alınmış, fiziksel ve teknik özellikleri incelenmiş, pratikte çalışan mühendisler açısından her bakımdan tüm bilgileri içeren bir kaynak oluşturma yoluna gidilmiştir.

Prekast ve öngerilmeli yapılara giriş yapıldıktan sonra boşluklu öngerilmeli döşeme elemanlarının fiziksel ve teknik özellikleri, ısı ses ve yangına karşı mukavemetleri, üretim metotları ve avantajları izah edilmiştir.

Daha sonra, bu elemanların yük taşıma kapasiteleri anlatıldıktan sonra birleşim detayları izah edilerek, bunların hesap metotları anlatılmıştır. Bu elemanların yatay ve düşey yük etkisi altındaki hesap esasları geniş bir şekilde ele alınmış ve dizayn prensipleri ACI 318-83 ve TS 3233 standartlarına göre izah edilerek örnek hesaplar verilmiştir. Daha sonra, uygulamada ortaya çıkan özel dizayn problemlerinin çözümleri örnekleriyle açıklanmıştır.

Sonuç olarak, bu tür öngerilmeli yapı elemanlarının konut yapımında kullanılmasının getireceği temel avantajlar özetlenmiştir.

TABLE OF CONTENTS

	Page No
LIST OF FIGURES i
LIST OF TABLESiii
LIST OF SYMBOLSiv
I- INTRODUCTION TO PRECAST AND PRESTRESSED STRUCTURES 1
1.1. Prestressed Concrete 1
1.1.1. General Design Principles 3
1.1.2. Pre-Tensioning 4
1.1.3. Post-Tensioning 5
1.2. Precast Concrete
II- INTRODUCTION TO HOLLOW CORE ELEMENTS 7
2.1. Methods of Manufacturing 7
2.2. Materials 7
2.3. Advantages of Hollow Core Slabs 8
2.4. Framing Concepts 9
III- PHYSICAL CHARACTERISTICS OF HOLLOW CORE SLABS 12
3.1. Fire Resistance 12
3.1.1. Simply Supported Elements 12
3.1.2. Structurally Continuous Slabs 14
3.1.3. Elements Restraint Against Thermal Expansion 18
3.2. Acoustical Properties 18
3.2.1. Approaching the Design Process 19
3.3. Thermal Insulation Parameters 21
3.4. Coordination with Mechanical, Electrical and Other Sub-Systems 22

	Page No
3.4.1. Electrified Floors	22
3.4.2. Ductwork	23
IV- LOAD CARRYING CHARACTERISTICS OF HOLLOW CORE SLABS	24
4.1. Explanation of Load Tables	25
4.1.1. Safe superimposed Load	25
4.1.2. Limiting Criteria	25
4.1.3. Estimated Camber	28
4.1.4. Concrete Strength and Density	29
4.1.5. Prestressing Strand and Losses	29
4.1.6. Strand Placement	30
4.1.7. Load Bearing Wall Panels	30
V- DESIGN OF CONNECTIONS	32
5.1. Criteria for Connections	32
5.2. Connection Design of Slab to Slab	33
5.3. Connection Design of Slab to Beam	35
5.4. Connection Design of Slab to Wall	38
5.5. Typical Beam to Column Details	40
VI- ANALYSIS AND DESIGN OF HOLLOW CORE SLABS	44
6.1. UNDER HORIZONTAL LOADS	44
6.1.1. An Overview of Earthquake Requirements	44
6.1.1.1. Turkish Earthquake Code	46
6.1.1.2. Uniform Building Code	47
6.1.2. Assumptions in Diaphragm Design	49
6.1.3. Analysis of Diaphragm Action	51
6.2. Under Vertical Loads	53
6.2.1. Flexural Resistance at Ultimate Limit State	54

	Page No
6.2.1.1. ACI (318-83), TS 3233 Code Equations	56
6.2.1.2. Analysis Using Strain Compatibility	58
6.2.3. Flexural Resistance at Service Limit State	61
6.2.4. Prestress Losses	65
6.2.5. Camber and Deflection	69
6.2.5.1. Camber	70
6.2.5.2. Deflection	72
6.2.6. Shear Design	74
VII- SPECIAL DESIGN CONSIDERATIONS	79
7.1. Load Distribution Mechanism	79
7.2. Effect of Openings	84
7.3. Continuity Over Supports	88
7.4. Design of Cantilevers	90
VIII- CONCLUSIONS	94
REFERENCES	96

LIST OF FIGURES

		Page No
1-	Simple rectangular beam prestressed concentrically	2
2-	Distribution of stresses at midspan of a simple beam concentrically prestressed	2
3-	Distribution of stresses at midspan of a simple beam under initial concentric prestressing force	3
4-	Distribution of stresses due to prestressing forces applied at lower third point of rectangular cross-section	3
5-	Keyway shears	11
6-	Moment diagrams for simply-supported beam or slab	13
7-	Moment diagram for two-span continuous beam	15
8-	Uniformly loaded element continuous at one support	16
9-	Symmetrical uniformly loaded element continuous at both supports	17
10-	Axially restrained beam during fire exposure	19
11-	Model of sound transmission process between rooms	19
12-	STC vs mass per unit area of single-leaf concrete walls and floors	20
13-	Use of electrical ducts with slabs within concrete topping	23
14-	Partial interaction curve for prestressed hollow-core wall panels	31
15-	Typical slab to slab connection	34
16-	Alternate longitudinal shear connections	35
17-	Multi-bay slab arrangement	36
18-	Typical slab to beam connections	37
19-	Exploded view of an interior floor to wall connection and the various connection forces	38
20-	Typical slab-to-wall connections	40
21-	Typical beam-to-column connection	42

	Page No
22- Elements of a lateral load resisting system	45
23- Simple beam action Type 1	51
24- Cantilever beam action Type 2	53
25- Nominal flexural resistance	55
26- Values of f_{ps} by stress-strain relationship-bonded strand	59
27- Flow chart for flexural resistance calculations	61
28- Calculation of service load stresses	62
29- Shear diagram	75
30- Distribution of irregular loads	80
31- Locations of maximum point loads	81
32- Distribution of irregular loads	82
33- Width to span ratio effect	83
34- Steel header detail at openings	85
35- Effects of openings	86
36- Continuity at butt joint	89
37- Corss-section of a cantilever hollow core slab	91

LIST OF TABLES

	Page No
1- Sound transmission values (STC), dB	21
2- "U" Values of composite sections (winter condition)	22
3- Safe superimposed service load and cambers for 1200 x 200 hollow core slab	26
4- Safe superimposed service load and cambers for 1200 x 300 hollow core slab	27
5- Correction factors for prestress losses	66
6- Long term multipliers	71
7- Maximum allowable computed deflections	72
8- Maximum point loads allowed on hollow core slabs	81

LIST OF SYMBOLS

A	=	Cross-sectional area
A_{ps}, A'_{ps}	=	Area of prestressed reinforcement
A_s	=	Area of non-prestressed tension reinforcement
A'_s	=	Area of non-prestressed compression reinforcement
A_v	=	Area of shear reinforcement
a	=	Depth of equivalent rectangular stress block
b	=	Width of compression face of element
b_w	=	Net web width of hollow core slab
C	=	Base shear coefficient
C_o	=	Risk zone factor
C_w	=	Coefficient used for stress-strain relationship of bonded strand
c	=	Distance from extreme compression fibre to neutral axis
d	=	Distance from extreme compression fibre to centroid of tension reinforcement
d_p, d'_p	=	Distance from extreme compression fibre to centroid of prestressed tension reinforcement
d_s	=	Distance from extreme compression fibre to centroid of non-prestressed tension reinforcement
d'_s	=	Distance from extreme compression fibre to centroid of non-prestressed compression reinforcement
E_c	=	Modulus of elasticity of concrete
E_{ci}	=	Modulus of elasticity of concrete at time of initial prestress
E_s	=	Modulus of elasticity of steel reinforcement
e	=	Eccentricity of design load or prestress force parallel to axis measured from the centroid of the section
F	=	Earthquake force
F_f	=	Force required to develop the compressive resistance of the overhanging flanges
F_h	=	Horizontal shear force
f_b	=	Stress in the bottom fibre of the cross-section
f'_c	=	Specified compressive strength of concrete
f_{cds}	=	Stress in concrete at centroid of prestressed reinforcement due to superimposed dead load
f_{ci}	=	Compressive strength of concrete at time of initial prestress

f_{pe}	=	Compressive stress in concrete due to prestress only after all losses, at the extreme fibre of a section at which tensile stresses are caused by applied loads
f_{ps}, f'_{ps}	=	Stress in prestressed reinforcement
f_{ps}	=	Stress in prestressed reinforcement at nominal resistance
f_{pu}	=	Specified tensile strength of prestressed reinforcement
f_{se}	=	Effective stress in prestressed reinforcement after prestress losses
f_{pc}	=	Compressive stress in concrete at the centroid of the section due to effective prestress
f_t	=	Stress in the top fibre of the cross-section
f_y	=	Specified yield strength of non-prestressed tension reinforcement
h_f	=	Thickness of compression flange of an element
I	=	Structure importance factor
I	=	Moment of inertia
I_{cr}	=	Moment of inertia of cracked section transformed to concrete
L, l	=	Span length
M_e	=	Applied fire moment
M_{cr}	=	Cracking moment under combined loading
M_n	=	Nominal flexural resistance of a section
M_{sd}	=	Moment due to superimposed dead load (unfactored)
M_u	=	Factored moment at a section
m	=	Unfactored mass weight
P_i	=	Initial prestress force
P_o	=	Prestress force at transfer
S	=	Soil-Structure interaction factor
S	=	Section modulus
S_b	=	Section modulus with respect to the bottom fibre of a cross section
S_t	=	Section modulus with respect to the top fibre of a cross section
s	=	Shear reinforcement spacing
T	=	Fundamental period of vibration of the structure in the first mode (sec)
T	=	Tensile force
T_o	=	Predominant period of vibration of the underlying soil
TL	=	Total prestress loss
tg	=	Width of grout column in horizontal joint

V	=	Service load shear
V_c	=	Nominal shear resistance provided by the concrete
V_{ci}	=	Nominal shear resistance provided by concrete when diagonal cracking results from combined shear and moment
V_{cr}	=	Cracking shear under combined loading
V_{cw}	=	Nominal shear resistance provided by concrete when diagonal cracking results from excessive principal tensile stress in web
V_d	=	Service dead load shear (unfactored)
V_l	=	Service live load shear (unfactored)
V_{nh}, V_{nu}	=	Nominal shear resistance of the connection in the horizontal and vertical directions, respectively
V_p	=	Vertical component of the effective prestress force at the section being considered
w	=	Service load per unit area of slab (unfactored)
y_b	=	Distance from bottom fibre to centroid of the section
y_o	=	Distance from pick up point to the centroid of cross section
y_t	=	Distance from top fibre to centroid of the section
Z	=	Zone factor
ρ	=	A_s/bd = reinforcement ratio for non-prestressed tension reinforcement
ρ'	=	A'_s/bd = reinforcement ratio for non-prestressed tension reinforcement
ρ_p	=	A_{ps}/bd = reinforcement ratio for prestressed reinforcement
ϕ	=	ACI strength reduction factor
w	=	Reinforcement index (with subscripts)
ϵ_{ps}	=	Strain in prestressed reinforcement at nominal flexural strength
ϵ_s	=	Strain in prestressed reinforcement
ϵ_{se}	=	Strain in prestressed reinforcement after losses
θ	=	Subscript denoting fire conditions

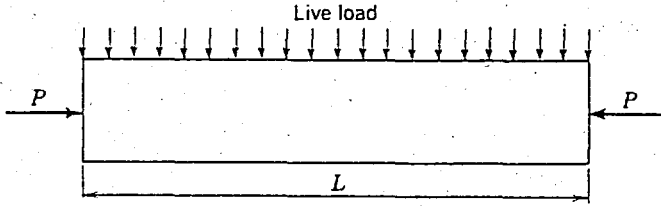

Fig. 1 Simple rectangular beam prestressed concentrically

There is a time-dependent reduction in the prestressing force, due to the creep and shrinkage of the concrete and the relaxation of the prestressing steel. If no tensile stresses are to be permitted in the concrete it is necessary to provide an initial prestressing force that is larger than would be required to compensate for the flexural stresses a reduction of the initial prestressing force by 10 to 30 percent. Therefore, if the stress distributions shown in Fig. 2 are desired after the loss of stress has taken place (under the effects of the final prestressing force), the distribution of stresses under the initial prestressing force would have to be as shown in Fig. 3. (Ref. 6)

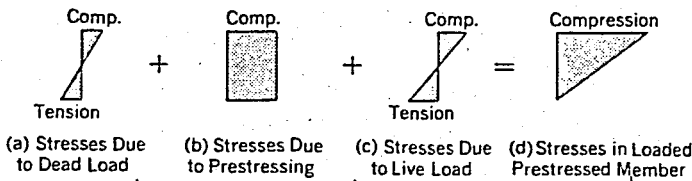

Fig. 2 Distribution of stresses at midspan of a simple beam concentrically prestressed

Prestressing with the concentric force just illustrated has the disadvantage that the top fiber is required to withstand the compressive stress due to prestressing in addition to the compressive stresses resulting from the design loads. Furthermore, since sufficient prestressing must be provided to compress the top fibers, as well as the bottom fibers, if sufficient prestressing is to be supplied to eliminate all of the flexural tensile stresses, the average stress due to the maximum flexural tensile stress resulting from the design loads.

If this same rectangular member were prestressed by a force applied at a point one-third of the depth of the beam from the bottom of the

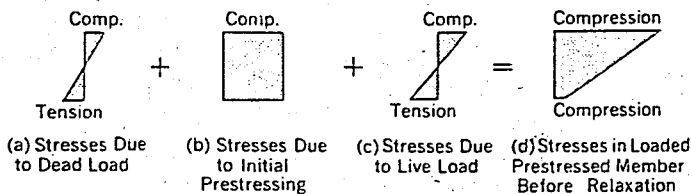

Fig. 3 Distribution of stresses at midspan of a simple beam under initial concentric prestressing force

beam, the distribution of the stresses due to prestressing would be as shown in Fig. 4 (Ref. 6). In this case, as in the previous example, the final stress in the bottom fibre due to prestressing should be equal in magnitude to the sum of the tensile stresses resulting from the design loads. By inspection of the two stress diagrams for prestressing (Figs. 2-b and 4), it is evident that the average stress in the beam, prestressed with the force at the third point, is only one-half of that required for the beam with concentric prestress. Therefore, the total prestressing of the second example will be only one-half of the amount required in the first example. In addition, the top fiber is not required to carry any compressive stress due to prestressing when the force is applied at the third point.

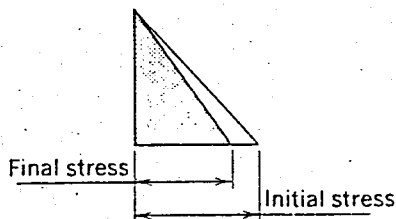

Fig. 4 Distribution of stresses due to prestressing forces applied at lower third point of rectangular cross section

The economy that results from applying the prestressing force eccentrically is obvious. Further economy can be achieved when small tensile stresses are permissible in the top fibers—these tensile stresses may be due to prestressing alone or to the combined effects of prestressing and any external loads that may be acting at the time of prestressing. This is because the required bottom-fibre prestress can be attained with a smaller prestressing force, which is applied at a greater eccentricity under such conditions.

1.1.2. Pre-Tensioning

Pre-tensioning is accomplished by stressing steel wires or strands, called tendons to a predetermined amount, and then while the stress is

maintained in the tendons, placing concrete around the tendons. After the concrete has hardened, the tendons are released and the concrete, which has become bonded to the tendons, is prestressed as a result of the tendons attempting to regain the length they had before they were stressed. In pretensioning the tendons are usually stressed by the use of hydraulic jacks. The stress is maintained during the placing and curing of the concrete by anchoring the ends of the tendons to abutments that may be as much as 150 m or more apart. The abutments and appurtenances used in this procedure are referred to as a pre-tensioning bed or bench. In some instance, rather than using pre-tensioning benches, as mentioned above, the steel molds or forms that are used to form the concrete members are designed in such a manner that the tendons can be safely anchored to the mold after they have been stressed. The results obtained with each of these methods is identical, and the factors involved in determining which method should be used are of concern to the fabricator of prestressed concrete, but do not usually affect the designer. The tendons used in pre-tensioned construction must be relatively small in diameter, because the bond stress between the concrete and the tendon is relied upon to transfer the stress from the tendon to the concrete. It should be recognized that the ratio of bond area to cross sectional area for a circular wire or bar is

$$\frac{\text{Bond Area}}{\text{Cross Section Area}} = \frac{4L}{d}$$

in which d is the diameter and L is length. For a unit length, it will be seen from the equation above that the ratio, which is also the ratio of the bond area available to the force the tendon can withstand, decreases as the diameter increases. Therefore, a number of the small tendons are normally required to develop the required prestressing force.

1.1.3. Post-Tensioning

When a member is fabricated in such a manner that the tendons are stressed and each end is anchored to the concrete section, after the concrete has been cast and has attained sufficient strength to safely withstand the prestressing force, the member is said to be post-tensioned. When using post-tensioning, a common method used in preventing the tendon

from bonding to the concrete during placing and curing of the concrete is to encase the tendon in a mortar-tight, metal tube (or flexible metal hose) before placing it in the forms. After the tendon has been stressed, the void between the tendon and the sheath is filled with grout. In this manner, the tendon becomes bonded to the concrete section and corrosion of the steel is prevented.

Post-tensioning offers a means of prestressing on the job site. This procedure may be necessary or desirable in some instances. Very large building or bridge girders that can not be transported from a precasting plant to the job site (due to their weight, size, or the distance between plant and job site) can be made by post-tensioning on the job site. Post tensioning is used in precast as well as in cast-in place construction. In addition, fabricators of pre-tensioned concrete will frequently post-tension the members for small projects on which the number of units to be produced does not warrant the expenditures required to set-up pre-tensioning facilities.

1.2. Precast Concrete

When concrete products are made in other than their final position, they are considered precast. They may be unreinforced, reinforced. They include in their number a wide range of products : block, brick, pipe, plank, slabs, conduit, joists, beams and girders, trusses and truss components, curbs, lintels, sills, piles, pile caps, and walls.

Precasting often is chosen because it permits efficient mass production of concrete units. With precasting, it usually is easier to maintain quality control and produce higher-strength concrete than with field concreting. Formwork is simpler, and a good deal of falsework can be eliminated. Also, since precasting normally is done at ground level, workers can move about more freely. But sometimes these advantages are more than offset by the cost of handling, transporting, and erecting the precast units. Also, joints may be troublesome and costly.

Design of precast products follows the same rules, in general, as for cast-in-place units. Precast units must be designed for handling and erection stresses, which may be more severe than those they will be subjected to in

service. Normally, inserts are embedded in the concrete for picking up the units. They should be picked up by these inserts, and when set down, they should be supported right side up, in such a manner as not to induce stresses higher than the units would have to resist in service.

II- INTRODUCTION TO HOLLOW CORE ELEMENTS

2.1. Methods of Manufacturing

A hollow core slab is a precast, prestressed concrete member with continuous voids provided to reduce weight and, therefore, cost and as a side benefit, to use for concealed electrical or mechanical runs. Primarily used as floor or roof deck systems, hollow core slabs also have applications as wall panels, spandrel members and bridge deck units.

Two basic manufacturing methods are currently in use for the production of hollow core slabs. One is dry cast or extrusion system where a very low slump concrete is forced through the machine. The cores are formed with augers or tubes with the concrete being compacted around the cores. The second system uses a higher slump concrete. Sides are formed either with stationary, fixed forms or with forms attached to the machine with the sides being slip formed. The cores in the normal slump, or wet cast, systems are formed with either light-weight aggregate fed through tubes attached to the casting machine, pneumatic tubes anchored in a fixed form or long tubes attached to the casting machine which slip form the cores.

The economy of a hollow core system is in the quantity of slabs that can be produced at a given time with a minimum of labor required. Each slab on a given casting line will have the same number of prestressing strands. Therefore, the greatest production efficiency is obtained by mixing slabs with the same reinforcing requirements from several projects on a single production line. This implies that best efficiency for a single project is obtained if slab requirements are repetitive.

2.2. Materials

Hollow core slabs are produced with two basic concrete mixes; low slump and normal slump concrete. For the low slump concretes, water content is limited to slightly more than is required for cement hydration.

Water-cement ratios are in the range of 30 percent. Mixing is critical because the limited water available must be well dispersed in the mix. Water reducing admixtures can be used to optimize a mix by reducing cement and water requirements while still retaining enough workability for proper compaction of the concrete by the machine. Air entrainment admixtures are not effective in the dry mix concrete. With the low water-cement ratios and compaction placing method, air is difficult to disperse well and maintain.

Aggregates vary in the manufacturing processes depending on what type is locally available. Maximum aggregate size rarely gets larger than gravel No. 1, because of the confined areas into which concrete must be placed. Concrete unit weights ranging from 18 to 24 kN/m³ are used in the industry.

2.3. Advantages of Hollow Core Slabs

Hollow core slabs are most widely known for providing economical, efficient floor and roof systems. The top surface can be prepared for the installation of a floor covering by feathering the joints with a latex cement, installing non-structural fill concretes ranging from 1 cm to 2 cm thick depending on the material used, or by casting a composite structural concrete topping. The underside can be used as a finished ceiling as installed, by painting, or by applying an acoustical spray.

When properly coordinated for alignment, the voids in a hollow core slab may be used for electrical or mechanical runs. Structurally, a hollow core slab provides the efficiency of a prestressed member for load capacity, span range, and deflection control. In addition, a basic diaphragm is provided for resisting lateral loads by the grouted slab assembly provided proper connections and details exist.

Excellent fire resistance is another attribute of the hollow core slab. Depending on thickness and strand cover, ratings up to a 4 hour endurance can be achieved. A fire rating is dependent on equivalent thickness for heat transmission, concrete cover over the prestressing strands for strength in a high temperature condition, and end restraint.

Used as floor-ceiling assemblies, hollow core slabs have the excellent sound transmission characteristics associated with concrete. The Sound Transmission Class rating ranges from about 47 to 57 dB without topping and the Impact Insulation Class rating starts at about 23 for a plain slab and may be increased to over 70 dB with the addition of carpeting and padding.

2.4. Framing Concepts.

The primary consideration in developing a framing scheme using hollow core slabs is the span length. For a given loading and fire endurance rating, span length and slab thickness may be optimized by consulting a producer's published load tables. For roof slabs, a span-depth ratio limit of 50 is suggested and for floor slabs, a limit of 40 is suggested. In practice a span-depth ratio of 45 is common for floors and roofs when fire endurance, openings, or heavy or sustained live loads do not control a design.

Consideration must be given to factors which affect slab thickness selection for a given span. Heavy superimposed loads, as required by the function of a system, would require a lower span-depth ratio. Similarly, heavy partitions or a large number of openings will result in higher load capacity requirements. The fire resistance rating required for the application will also affect the load capacity of a slab. As the code required fire rating increases, prestressing strands can be raised for more protection from the heat.

Hollow core members are cambered as with any other prestressed flexural member. In the planning stages, consideration should be given to the causes of differential camber. For two slabs of identical length and prestressing, the camber may be different because of concrete and curing variations. This factor is independent of a framing scheme. However, joints between slabs of unequal spans, or joints at which a change in span direction occurs, will cause a potential differential camber problem. This must be recognised and dealt with in the design layout.

Camber must also be accommodated when a topping is to be provided. The quantity of topping required must consider the amount of camber and the function of the floor. In occupancies where flat floors are

not a requirement, a constant topping thickness may be used to follow the curvature of the slabs.

Hollow core slabs are designed as individual one way , simple span slabs. When the slabs are installed and grouted at the keyways, the individual slabs become a system that behaves similarly to a monolithic slab. A major benefit of the slabs acting together is the ability to transfer forces from one slab to another. In most hollow core slab deck applications, non-uniform loading occurs in the form of line loads, concentrated loads, or load concentrations at openings. The ability of individual slabs to interact allows these load concentrations to be shared by several slabs. In many cases, load concentrations do not have to be carried by the slabs. For example, a header at a large opening may be supported directly to a foundation or vertical support element; a beam might be installed to directly carry a heavy concentrated load; or a heavy wall parallel to a slab span might be designed to carry its own weight or any load superimposed on the wall as a deep beam spanning between vertical support.

As load is applied to one slab in a system, the response of the slab is to deflect and also twist if the load is not on the longitudinal centerline of the system. As the loaded edges try to move down, the interlock of the grout in the joints with the keyways formed in the slab edges forces the adjacent slabs to deflect a similar amount. The flexural and torsional stiffness of the adjacent slabs reduce the deflection of the loaded slab from what might be expected if the slab were alone. Shear forces are developed along the keyways and the loaded slab then gets some support from the adjacent slabs. As this effect trickles through the system, the keyways between slabs force equal deflections for slab edges at any given keyway.

Many times shrinkage cracks will occur in the grouted joints at the interface between the grout and slab edge. This cracking does not impair the mechanism described above because the configuration of the keyways in the slab edges still provides mechanical interlock even with the presence of a crack.

Shear forces transferred along keyways cause two sets of forces that are normally not considered in hollow core slab design. The first is torsion

which develops because the shear on one edge of a given slab is different in magnitude from the shear on the opposite edge. As depicted in Figure 5 (Ref. 5), the keyway shears reduce as the distance from the load increases. These torsions cause shear stress in the slabs in addition to the direct shear stress.

The second set of forces is induced because the system is tending to behave as a two way slab. Transverse bending moments occur because of the edge support provided by adjacent slabs. The result is transverse tensile stress developed in the bottom of the slab and compressive stress in the top.

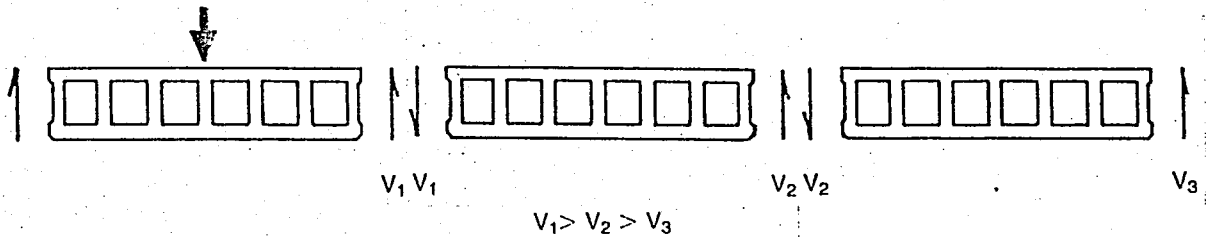

Fig. 5 Keyway shears

Several factors affect the ability of a slab system to distribute loads to adjacent slabs. As the width of an assembly of slabs gets narrower than the span length, a reduction in the number of slabs contributing to the support of a concentration of load occurs. This occurs because the freedom of the free edges of the system to deflect and twist becomes more significant. A second factor is the spacing of the slab joints. With slabs available in widths ranging from 60 cm to 240 cm, some differences in load distribution behavior can be expected. Finally, the span length affects the number of contributing slabs. As span length changes for a wide system, the interaction of flexural and torsional stiffnesses changes. For longer spans, flexural stiffness reduces relative to torsional stiffness. This results in relatively less slab rotation and less transverse curvature. The result is that more slabs can contribute to distribution on longer spans as long as the system is wide relative to its length.

III- PHYSICAL CHARACTERISTICS OF HOLLOW CORE SLABS

3.1. Fire Resistance

One of the attributes of hollow core slab construction is excellent fire resistance. The fire resistance of precast prestressed concrete elements and assemblies can be determined in most cases by calculation. These calculations are based on engineering principles and take into account the conditions of a standard fire test. This is known as the Rational Design Method of determining fire resistance. It is based on extensive research conducted by the National Research Council, the Portland Cement Association, and many other laboratories in Europe and America.

Many fire tests and related research studies have been directed toward an understanding of the structural behaviour of prestressed concrete subjected to fire. The purpose of this section is to present an introduction to the calculation procedures. Because the method of support is the most important factor affecting structural behaviour of flexural elements during fire, the discussion that follows deals with three conditions of support : Simply supported elements, continuous slabs and beams, and elements in which restraint to thermal expansion occurs.

3.1.1. Simply Supported Elements

Assume that a simply supported prestressed concrete slab is exposed to fire from below, that the ends of the slab are free to rotate, and that expansion can occur without restriction. Also assume that the reinforcement consists of straight strands located near the bottom of the slab. With the underside of the slab exposed to fire, the bottom will expand more than the top, causing the slab to deflect downward; also, the strength of the steel and concrete near the bottom will decrease as the temperature rises. When the strength of the steel diminishes to that required to support the slab, flexural collapse will occur. In essence, the applied moment remains practically constant during the fire exposure, but the resisting moment capacity is reduced as the steel weakens.

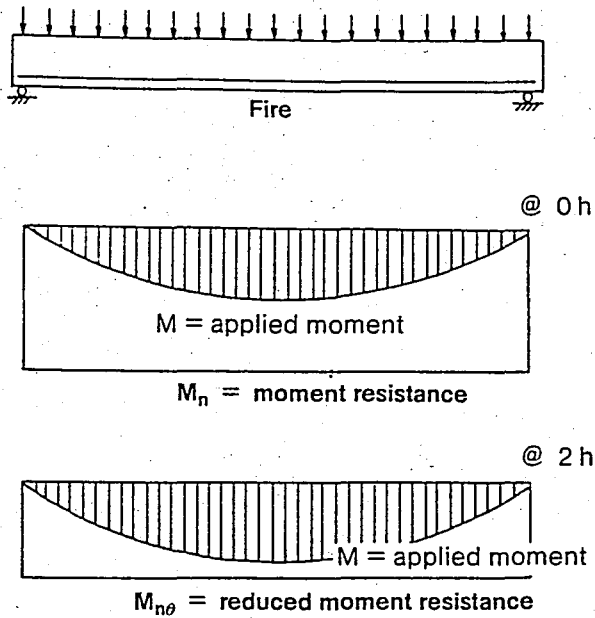

Fig. 6 Moment diagrams for simply-supported beam or slab

Fig. 6 (Ref. 8) illustrates the behaviour of a simply supported slab exposed to fire from beneath as described above. Because strands are parallel to the axis of the slab, the factored flexural resistance is constant throughout the length:

$$M_u = \phi M_n = \phi A_{ps} f_{ps} (d-a/2)$$

Where;

$$\phi = 0.90$$

A_{ps} = Cross-sectional area of the prestressed reinforcement

f_{ps} = Stress in the prestressed reinforcement at nominal flexural resistance

d = Distance from the centroid of the prestressed reinforcement to the extreme compression fibre

a = Depth of the equivalent rectangular compression stress block at nominal flexural resistance, and is equal to

$$a = A_{ps} f_{ps} / 0.85 f'_c b$$

where f'_c is the specified compressive strength of the concrete and b is the width of the slab.

M_n = Nominal flexural resistance

In lieu of an analysis based on strain compatibility, the value of f_{ps} can be assumed to be :

$$f_{ps} = f_{pu} (1 - 0.5 A_{ps} f_{pu} / b d f_c')$$

where f_{pu} is the specified tensile strength of the prestressed reinforcement parabolic with a maximum value at midspan of :

$$M = w l^2 / 8 \quad \text{where :}$$

$$w = \text{Dead plus live load per unit of length}$$

$$l = \text{Span length}$$

As the material strengths diminish with elevated temperatures, the retained nominal resistance becomes :

$$M_{n\theta} = A_{ps} \cdot f_{ps\theta} (d - a_{\theta} / 2)$$

In which θ signifies the effects of high temperatures. Note A_{ps} and d are not affected, but f_{ps} is reduced. Similarly a_{θ} is reduced, but the concrete strength at the top of the slab, f_c' is generally not reduced significantly because of its lower temperature.

Flexural failure can be assumed to occur when $M_{n\theta}$ is reduced to M . The resistance factor, ϕ is not applied because a safety factor is included in the required ratings. From this expression, it can be seen that the fire endurance depends on the applied loading and on the strength-temperature characteristics of the reinforcement.

Test results have shown that the theory discussed above is valid, not only for hollow core floors, but also for roofs with insulation on top of the slabs.

3.1.2. Structurally Continuous Slabs

Continuous elements undergo changes in stresses when subjected to fire. These stresses result from temperature gradients within the structural elements, or changes in strength of the materials at high temperatures, or both.

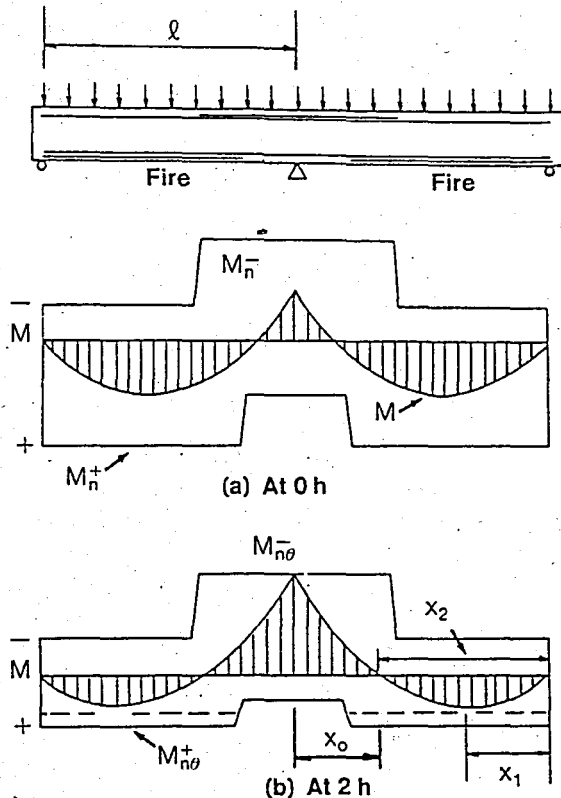

Fig. 7 Moment diagram for two-span continuous beam

Fig. 7 (Ref. 8) Shows a two-span continuous beam whose underside is exposed to a fire test. The bottom of the beam becomes hotter than the top and tends to expand more than the top. This differential temperature effect causes the ends of the beam to tend to lift from their supports thereby increasing the reaction at the interior support. This action results in a redistribution of moments, i.e., the negative moment at the interior support increases while the positive moments decrease. During a fire, the negative moment reinforcement remains cooler than the positive moment reinforcement because it is better protected from the fire. In addition, the redistribution that occurs is sufficient to cause yielding of the negative moment reinforcement. Thus, a relatively large increase in negative moment can be accommodated throughout the test. The resulting decrease in positive moment means that the positive moment reinforcement can be heated to a higher temperature before failure will occur. Therefore, the fire endurance of a continuous concrete beam is generally significantly longer than that of a simply supported beam having the same cover and the same applied loads.

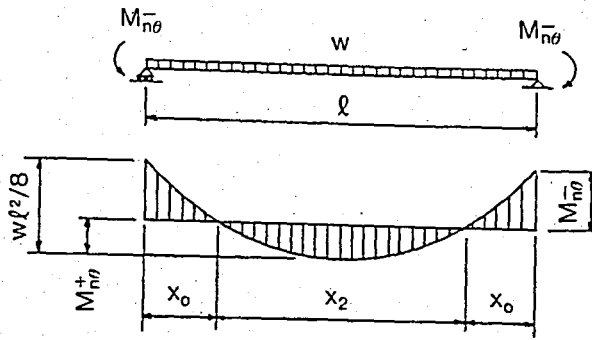

Fig. 9 Symmetrical uniformly loaded element continuous at both supports

$$M_{ne}^- = wl^2 / 8 - M_{ne}^+ \quad M_{ne}^+ = \frac{w x_2^2}{8} \quad x_2 = \sqrt{\frac{8 M_{ne}^+}{w}}$$

$$x_0 = \frac{1}{2} (1 - x_2) = \frac{1}{2} - \frac{1}{2} \sqrt{\frac{8 M_{ne}^+}{w}}$$

To determine the maximum value of x_0 , the value of w should be the minimum service load anticipated, and $(wl^2/8 - M_{ne})$ should be substituted for M_{ne} in the equation :

$$x_0 = \frac{1}{2} - \frac{1}{2} \sqrt{\frac{8 M_{ne}^+}{w}}$$

For any given fire endurance period, the value of M_{ne} can be calculated by the procedures given in the section on simply-supported elements. Then the value of M_{ne} can be calculated by the use of the two preceding equations :

$$M_{ne}^- = \frac{wl^2}{2} + w l^2 \sqrt{\frac{2 M_{ne}^+}{wl^2}} \quad \text{or} \quad M_{ne}^- = \frac{wl^2}{8} - M_{ne}^+$$

and the necessary lengths of the negative moment reinforcement can be determined from :

$$x_0 = \frac{2 M_{ne}^-}{wl} \quad \text{or} \quad x_0 = \frac{1}{2} - \frac{1}{2} \sqrt{\frac{8 M_{ne}^+}{w}}$$

It should be noted that the amount of moment redistribution that can occur is dependent on the amount of negative moment reinforcement. Tests conducted by laboratories have clearly demonstrated that in most cases, the negative moment reinforcement will yield, so the negative moment capacity is reached early during a fire test, regardless of the applied

loading. The designer must exercise care to ensure that a secondary type of failure will not occur. To avoid a compression failure in the negative moment region, the amount of negative moment reinforcement should be small enough so that $W_o = A_s f_{yo} / b_o d_o f_{co}$, is less than 0.30, before and after reductions in f_y , b , d and f_c are taken into account. Furthermore, the negative moment bars or mesh must be long enough to accommodate the complete redistributed moment and change in the inflection points. It should be noted that the worst condition occurs when the applied loading is smallest, such as the dead load plus partial or no live load. It is recommended that at least 20 percent of the maximum negative moment reinforcement extend throughout the span.

3.1.3. Elements Restrained Against Thermal Expansion

If a fire occurs beneath an interior portion of a large reinforced concrete slab, the heated portion will tend to expand and push against the surrounding part of the slab. In turn, the unheated part of the slab exerts compressive forces on the heated portion. The effects of restraint to thermal expansion can be characterized as shown in Fig. 10 Ref. (8) The thermal thrust acts in a manner similar to an external prestressing force, which, in effect, increases the positive moment capacity.

The increase in bending moment capacity is similar to the effect of added reinforcement located along the line of action of the thrust. It can be assumed that the added reinforcement has a yield strength (force) equal to the thrust. By this approach, it is possible to determine the magnitude and location of the required thrust to provide a given fire endurance.

The above explanation is greatly simplified because in reality, restraint is quite complex, and can be likened to the behaviour of a flexural element subjected to an axial force.

3.2. Acoustical Properties

The basic purpose of architectural acoustics is to provide a satisfactory environment in which desired sounds are clearly heard by the intended listeners and unwanted sounds (noise) are isolated or absorbed.

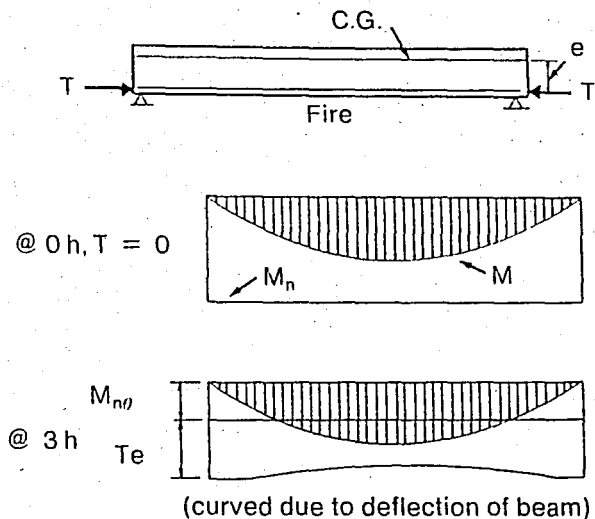
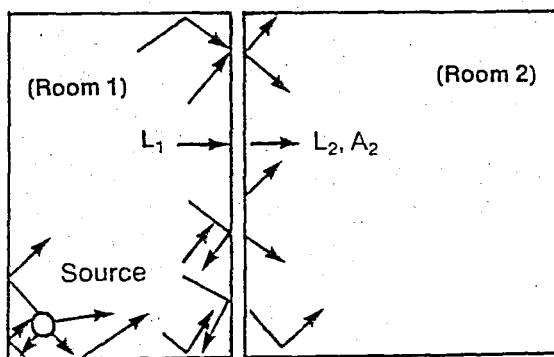

Fig. 10 Axially restrained beam during fire exposure

Good acoustical design utilizes both absorptive and reflective surfaces, sound barriers and vibration isolators.

3.2.1. Approaching the Design Process

The basic process of sound transmission between rooms is illustrated in Fig. 10 (Ref. 8). A sound source in Room 1 produces an average sound pressure level L_1 in the room; a fraction of the sound power incident on the partition between rooms is transmitted to room 2, where it produces an average sound pressure level L_2 .



In Room 1, L_1 is the average level produced by the sound source; in Room 2, L_2 is the average level of sound due to transmission through the partition, and A_2 is the sound absorption of the room in metric sabins.

Fig. 11 Model of sound transmission process between rooms.

The equation governing this process is :

$$L_1 - L_2 = TL - 10 \text{ Log } (S / A_2)$$

where TL-is the transmission loss of the partition, i.e., the ratio of sound power incident on the partition to that transmitted through it, S is the area of the partition, and A_2 is the sound absorption in the receiving room. Thus the reduction in level between rooms depends on the TL of the partition, the area of the partition, and the sound absorption in the receiving room. To simplify the acoustical design process, it is customary to replace the detailed TL data by a single number rating known as the sound transmission class (STC)*. For a partition whose transmission loss characteristic is known, the sound transmission class is determined by comparing the TL curve with a family of idealized TL curves known as STC contours. The rating process involves selecting the highest STC contour relative to which the actual TL curve has an average deficiency of no more than 2dB over the frequency range 125 to 4000 Hz.

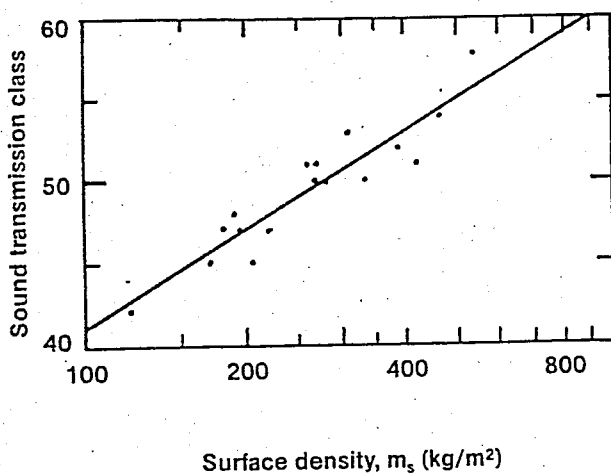

Straight line corresponds to $STC = 20 \log m_s + 1$

Fig. 12 STC vs. mass per unit area of single-leaf concrete walls and floors.

* ASTM Standard Method E90- Laboratory measurement of airborne sound transmission loss of building partitions. American Society for Testing and Materials, 1916 Race St., Philadelphia, PA, USA, 19103.

A massive concrete wall or floor is intrinsically a good barrier to sound transmission. Figure 12 (Ref 8) shows the relation between the mass per unit area of such walls and the sound transmission class. The data points are for actual walls and floors measured in the laboratory or in buildings. The straight line, empirically fitted to the points, is $STC = 20 \log m_s + 1$, where m_s is the surface density in kg/m^2 .

- SOUND TRANSMISSION (STC), dB	
150 mm	50
150 mm SLAB + 50 mm TOPPING	51
200 mm	56
200 mm SLAB + 50 mm TOPPING	59

Table 1- Sound Transmission Values (STC), dB

Table 1- Ref (10) contains values for the Sound Transmission Class (STC) utilizing hollow core slabs respectively. The larger the value of the STC for a given system, the greater the sound insulation.

3.3. Thermal Insulation Parameters

Precast and prestressed concrete construction has a unique advantage, with its thermal inertia and thermal storage properties. These provide a bonus which minimizes the energy needed to heat, cool and operate a buildings.

Table 2- (Ref. 10) contains the insulation values ("U" Factors) for hollow core slabs in conjunction with a varied range of commonly used insulation materials, respectively. All tabular values listed herein are based upon coefficients tabulated in the A.S.H.R.A.E. Guide. Thermal coefficients of insulation materials are selected from manufacturers data sheets.

For all standart uses in composite cross sections applications are as listed. Variation in slab conductivity will vary slightly with change in slab thickness as noted in tables. Insulation materials other than those noted

may be compared to the selected material and values chosen accordingly from the table 2 (Ref. 10)

- "U" VALUES OF COMPOSITE SECTIONS (Winter Condition)						
		SLAB THICKNESS, mm				
		100	150	200	250	300
		U	U	U	U	U
TYPE OF ROOF INSULATION	K	$\frac{W}{\text{Km}^2}$	$\frac{W}{\text{Km}^2}$	$\frac{W}{\text{Km}^2}$	$\frac{W}{\text{Km}^2}$	$\frac{W}{\text{Km}^2}$
25 POLYSTYRENE	0.98	0.80	0.78	0.76	0.72	0.71
50 POLYSTYRENE	0.98	0.48	0.46	0.45	0.44	0.43
25 BEAD BOARD	1.27	0.96	0.92	0.88	0.85	0.81
50 BEAD BOARD	1.27	0.58	0.57	0.56	0.53	0.52
25 URETHANE	0.83	0.72	0.70	0.67	0.65	0.64
50 URETHANE	0.83	0.41	0.41	0.39	0.39	0.38
25 CELLULAR GLASS	1.86	1.21	1.15	1.09	1.04	0.99
50 CELLULAR GLASS	1.86	0.78	0.74	0.72	0.71	0.69
25 PERLITE BOARD	1.76	1.17	1.12	1.07	1.02	0.96
50 PERLITE BOARD	1.76	0.74	0.72	0.70	0.67	0.66
NO INSULATION	-	2.76	2.45	2.23	2.00	1.85

Table 2- "U" Values of Composite Sections (Winter Condition)

3.4. Coordination with Mechanical, Electrical and Other Sub-Systems

Prestressed and precast concrete is used in a wide variety of buildings, and its integration with lighting, mechanical, plumbing, and other services is of importance to the designer. Because of increased environmental demands, the ratio of costs for mechanical and electrical installations to total building cost has increased substantially in recent years.

3.4.1. Electrified Floors

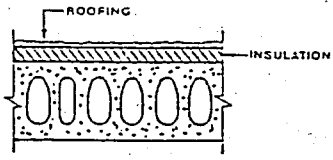
The increasing use of business machines, telephones and other communication systems stresses the need for adequate and flexible means of

supplying electricity and communication service. Since a cast-in-place topping is usually placed on prestressed floor elements, conduit runs and floor outlets can be readily buried within this topping. Moreover, voids in hollow-core slabs can also be used as electrical raceways as seen from the Fig. 13 (Ref. 8)

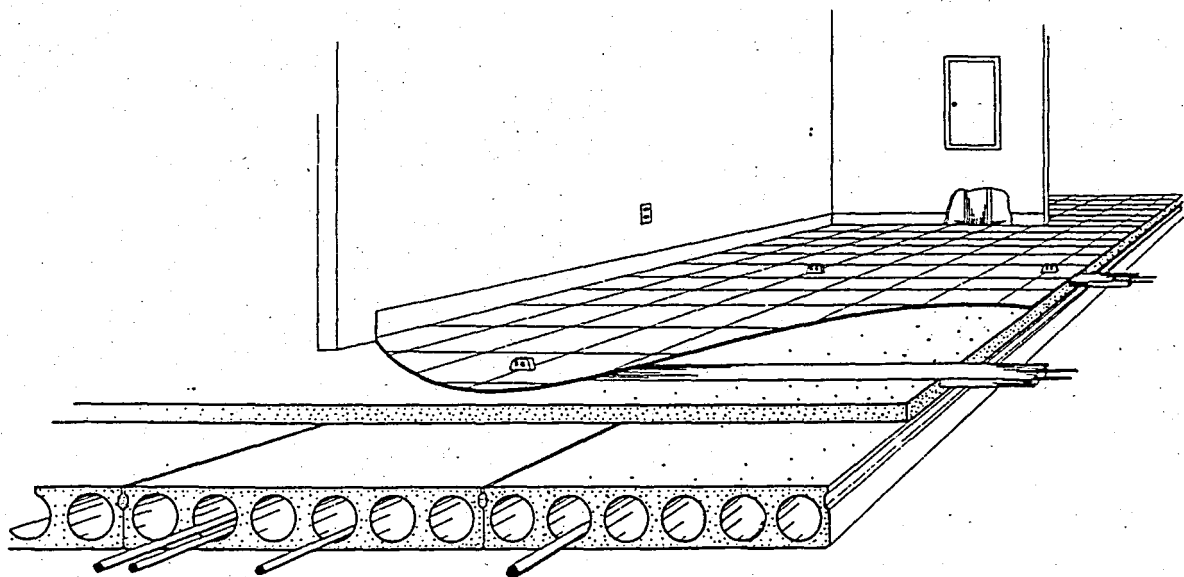

Fig. 13 Use of electrical ducts with slabs within concrete topping

3.4.2. Ductwork

Prestressed concrete hollow core girders have been used to serve a triple function as air conditioning distribution ducts, conduit for utility lines and structural supporting elements for the roof deck units. Conditioned air can be distributed within the void area of the girders and then introduced into the building work areas through holes cast into the sides and bottoms of the box girders. The system is balanced by plugging selected holes. Suspended ceilings, crane rails, and other sub-systems can be easily accommodated with standart manufactured hardware items and embedded plates.

IV- LOAD CARRYING CHARACTERISTICS

The load tables presented herein define the allowable live load that a given slab can safely support in addition to the slab self weight. The load capacity will be a function of the slab thickness, the amount of prestressing provided, and the effective depth of the prestressing strand. Fire rated slabs may require additional concrete cover below the strands which will affect the load capacity. The design criteria used to develop these load tables are defined by TS 3233 and ACI Building Code. Depending on the design criteria controlling a slab's load capacity, some advantage may be gained by understanding that in most applications, superimposed loads will consist of both dead and live loads. Where ultimate strength controls, an equivalent live load can be used to enter a load table. It is calculated as :

$$W_{\text{equivalent}} = 1.4 / 1.7 \text{ Dead load} + \text{Live load}$$

However, if bottom fiber tensile stresses control, no adjustment in superimposed loads may be used. Similarly, many loading conditions consist of loads other than uniform loads. For preliminary design only, an equivalent uniform load may be calculated from the maximum moment caused by the actual loads.

$$W_{\text{equivalent}} = 8 M_{\text{superimposed}} / l^2$$

Shear will not be properly addressed in this situation. Thus; the final design must consider the actual load pattern.

The load tables on the following pages show dimensions, section properties and engineering capabilities of the shapes most commonly used throughout the industry. The dimensions of the shapes shown in the tables may vary among manufacturers. Adjustment for these minor variations can be made by the designer. Hollow core slabs of different thicknesses, core sizes and shapes are available in the market under various trade names. Designers making use of these load tables should contact the manufacturers in the geographic area of the proposed structure to deter-

mine availability and exact dimensions of products shown here. Manufacturers will usually have their own load tables for sections which are not included on the following pages..

4.1. Explanation of load Tables

Load tables show the allowable superimposed service load, estimated camber at the time of erection and the estimated long-time camber after the element has essentially stabilized. The upper table gives the information for the element with no topping, and the lower table is for the same element with 50 mm of normal density concrete topping acting compositely with the precast section. Values in the tables assume a uniform 50 mm topping the full span length, and assume the element to be unshored at the time the topping is placed. Safe loads and cambers shown in the tables are based on the dimensions and section properties shown on the page, and will vary for elements with different dimensions.

4.1.1. Safe Superimposed load

The values for safe superimposed service load are based on the capacity of the element as governed by the code limitations on flexural resistance, service load flexural stresses and shear resistance. A portion of the safe load shown is assumed to be dead load for the purpose of applying load factors and determining time dependent cambers and deflections. For untopped hollow core slabs, 0.5 kN/m^2 of the capacity shown is assumed as superimposed dead load. For topped hollow core elements, 0.7 kN/m^2 of the capacity shown is assumed as superimposed dead load. The capacity shown is in addition to the dead load of the topping.

4.1.2. Limiting Criteria

The criteria used to determine the safe superimposed load and the strand placement are based on requirements of the code. A summary of the code provisions used in the development of these load tables is as follows.

Factored Flexural Resistance :

Load factors : 1.4 for dead load, 1.6 for live load

Resistance factor : $\phi = 0.90$

1200 x 200
Normal Density Concrete

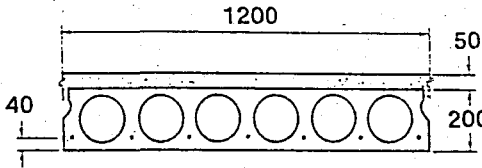

f'_{ci} = 25 MPa
 f'_c = 35 MPa

Section Properties

	Untopped	Topped
A =	134 000 mm ²	
I =	651 x 10 ⁶ mm ⁴	1303 x 10 ⁶ mm ⁴
y _b =	100 mm	139 mm
y _t =	100 mm	111 mm
S _b =	6 508 x 10 ³ mm ³	9 371 x 10 ³ mm ³
S _t =	6 508 x 10 ³ mm ³	11 735 x 10 ³ mm ³
b _w =	300 mm ²	300 mm
m =	265 kg/m ²	387 kg/m ²
w =	2.6 kN/m ²	3.8 kN/m ²
V/S =	48 mm	

Table of safe superimposed service load (kN/m²) and cambers (mm)

No Topping

Strand Code (kN/slab)	Span (m)												
	4.5	5.0	5.5	6.0	6.5	7.0	7.5	8.0	8.5	9.0	9.5	10.0	
600	13.4 0 10	10.5 0 10	8.3 0 10	6.6 0 0	5.3 0 0	4.3 0 0	3.5 0 0	2.8 0 0	2.3 0 0	1.8 0 -10			
800		13.5 10 10	11.4 10 10	9.3 10 10	7.6 10 10	6.3 10 10	5.2 10 10	4.3 10 0	3.5 0 0	2.0 0 0	2.3 0 0	1.8 0 -10	
1000				11.1 10 20	9.6 10 20	8.0 10 20	6.6 10 10	5.5 10 10	4.6 10 10	3.8 10 0	3.1 10 0	2.6 10 0	
1200					10.3 20 20	9.3 20 20	7.8 20 20	6.6 20 20	5.6 20 20	4.8 20 20	4.0 20 10	3.4 20 0	
1400							8.5 20 30	7.2 30 30	6.2 30 30	5.3 30 30	4.5 20 20	3.9 20 20	

Table of safe superimposed service load (kN/m²) and cambers (mm)

50 mm Normal Density Topping

Strand Code (kN/slab)	Span (m)											
	5.0	5.5	6.0	6.5	7.0	7.5	8.0	8.5	9.0	9.5	10.0	
600	13.0 0 0	10.2 0 0	8.1 0 0	6.4 0 0	5.1 0 0	3.8 0 0	2.7 0 -10	1.7 0 0				
800		14.1 10 10	11.3 10 10	9.2 10 10	7.5 10 0	5.8 10 0	4.5 10 0	3.3 0 -10	2.4 0 0	1.6 0 -20		
1000			13.4 10 10	11.7 10 10	9.7 10 10	7.8 10 0	6.2 10 0	4.9 10 0	3.8 10 0	2.8 10 -10	2.0 0 -20	
1200					11.1 20 20	9.8 20 10	8.0 20 10	6.5 20 10	5.2 20 10	4.1 20 0	3.1 10 0	
1400							9.4 30 20	8.0 30 20	6.6 30 10	5.3 20 10	4.3 20 0	

Table 3- Safe superimposed service load and cambers for 1200 x 200 hollow core slab

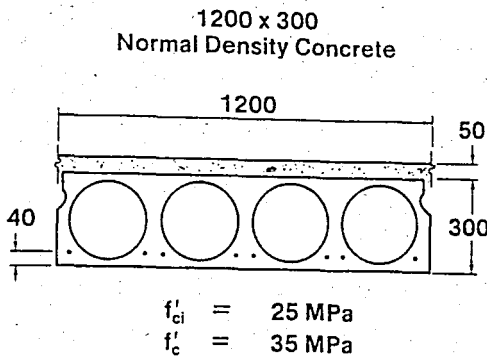

Section Properties

	Untopped	Topped
A =	179 000 mm ²	
I =	2 049 x 10 ⁶ mm ⁴	3 421 x 10 ⁶ mm ⁴
y _b =	150 mm	194 mm
y _t =	150 mm	156 mm
S _b =	13 657 x 10 ³ mm ³	17 635 x 10 ³ mm ³
S _t =	13 657 x 10 ³ mm ³	21 931 x 10 ³ mm ³
b _w =	240 mm	240 mm
m =	357 kg/m ²	479 kg/m ²
w =	3.5 kN/m ²	4.7 kN/m ²
V/S =	60 mm	

Table of safe superimposed service load (kN/m²) and cambers (mm) No Topping

Strand Code (kN/slab)	Span (m)																
	7.0	7.5	8.0	8.5	9.0	9.5	10.0	10.5	11.0	11.5	12.0	12.5	13.0	13.5	14.0	14.5	15.0
800	11.2 10 10	9.4 10 10	7.9 10 10	6.7 10 10	5.7 10 10	4.8 0 0	4.1 0 0	3.4 0 0	2.9 0 0	2.4 0 0	2.0 0 -10	1.6 0 -20					
1000		11.2 10 10	10.3 10 10	8.9 10 10	7.7 10 10	6.6 10 10	5.7 10 10	4.9 10 10	4.2 10 0	3.6 0 0	3.0 0 0	2.5 0 -10	2.1 0 -10	1.7 0 -20			
1200					9.0 20 20	8.2 20 20	7.1 20 20	6.2 10 10	5.4 10 10	4.6 10 10	4.0 10 0	3.4 10 0	2.9 0 0	2.4 0 -10	2.0 0 -20	1.6 0 -30	
1400							8.0 20 20	7.3 20 20	6.4 20 20	5.6 20 20	4.9 20 10	4.3 20 10	3.7 10 0	3.2 10 0	2.7 0 0	2.3 0 -10	1.9 0 -30
1600									7.2 30 30	6.3 30 30	5.6 20 30	4.9 20 20	4.3 20 20	3.8 20 10	3.3 20 0	2.9 10 0	2.5 10 -10

Table of safe superimposed service load (kN/m²) and cambers (mm) 50 mm Normal Density Topping

Strand Code (kN/slab)	Span (m)														
	7.0	7.5	8.0	8.5	9.0	9.5	10.0	10.5	11.0	11.5	12.0	12.5	13.0	13.5	14.0
800	12.6 10 10	10.5 10 10	8.7 10 0	7.3 10 0	6.1 10 0	5.1 0 0	4.2 0 0	3.4 0 0	2.6 0 -10	1.8 0 -10					
1000			11.0 10 10	9.7 10 10	8.3 10 10	7.0 10 0	6.0 10 0	5.0 10 0	4.0 10 0	3.1 0 0	2.4 0 -10	1.7 0 -20			
1200					8.8 20 10	7.7 20 10	6.6 10 10	5.4 10 0	4.5 10 0	3.6 10 0	2.8 10 -10	2.2 0 -20	1.6 0 -30		
1400							7.7 20 10	6.9 20 10	5.8 20 10	5.8 20 0	4.8 10 0	4.0 10 0	3.2 10 -10	2.5 10 -20	1.9 10 -30
1600									6.8 30 20	6.0 30 10	5.1 20 10	4.2 20 0	3.5 20 0	2.8 10 -10	

Table 4- Safe superimposed service load and cambers for 1200 x 300 hollow core slab

partitions or folding doors, should be placed with adequate allowance for error. Calculation of topping quantities should also recognise that the values can vary.

4.1.4. Concrete Strength and Density

Twenty-eight day cylinder strength for concrete in the prestressed units is assumed to be 350 kg/cm^2 . Tables for units with composite topping are based on the topping concrete being normal density concrete with a cylinder strength of 200 kg/cm^2 . For hollow core slabs the concrete strength at time of strand tension release is 250 kg/cm^2 unless the value falls below the heavy line shown in the load table, indicating that a cylinder strength greater than 250 kg/cm^2 is required. No values are shown when the required release strength exceeds 300 kg/cm^2 . The designer should recognise that it is sometimes difficult to obtain a release strength higher than 250 kg/cm^2 on a one day casting cycle. In such cases, the cost of production will be increased and the designer should consult with prospective producers when required release strengths are above 250 kg/cm^2 .

Many prestressing plants prefer to use higher strength concretes resulting in somewhat higher allowable loads or greater spans than indicated in the load tables contained herein. In this chapter, all tables apply to normal density concrete only, with the density assumed as 2400 kg/m^3 .

4.1.5. Prestressing Strand and Losses

For the hollow core elements the manufacturer is allowed some flexibility in choice of strand size and tensile strength. The "Strand Code" number shown in the first column of the strand area (A_{ps}) and the specified tensile strength (f_{pu}) expressed in kN per slab.

As an example, for a 1200×200 hollow-core slab with a strand code of 1000, the total value of $A_{ps} f_{pu}$ required would be 1000 kN/slab . If the producer uses 18600 kg/cm^2 strand, the total strand area required would be $(1000/18600) \cdot 1000 = 5.38 \text{ cm}^2$. The producer might then choose, for instance, to use 6-13 mm diameter strands ($A_{ps} = 6 \times 99 = 5.94 \text{ cm}^2$) or 4-13 mm diameter and 3-9 mm diameter strands ($A_{ps} = 4 \times 99 + 3 \times 55 = 5.61 \text{ cm}^2$),

or another combination of size and strength to produce a total value of $A_{ps} \cdot f_{pu}$ of at least 1000 kN/slab.

Losses assumed in computing the required concrete strength at time of strand release are 10 percent. Total losses are assumed to be 21 percent for normal density concrete. For long span, heavily prestressed products, losses may be somewhat higher than these assumed values, and for shorter spans with less prestressing they may be lower. However, these values will usually be adequate for element selection.

4.1.6. Strand Placement

For hollow core deck elements, the load table values are based on strand centred 40 mm from the bottom of the slab. Strand placement can vary from as low as 25 mm to as high as 55 mm from the bottom, which will change the capacity and camber values shown. The higher strand placements give improved fire resistance ratings. The lower strand placement may require higher release strengths, or top tension reinforcement at the ends.

4.1.7. Load Bearing Wall Panels

An interaction curve for various types of commonly used wall panels is provided herein. (Ref. 8) This interaction curve is for factored loads and moments and the appropriate load factors must be applied to the service loads and moments before entering the chart. Also, the curve is for short elements. Moment magnifiers caused by slenderness effects must be calculated and applied to the design moments before using the curve for final element selection. Most of the wall panel curves show the lower portion of the curve only (flexure controlling). Actual design loads will rarely exceed the values shown.

Full development has been assumed for prestressed wall panels. The effects of strands above the neutral axis has been neglected for the calculation of the flexural resistance under zero axial load. This curve for hollow-core wall panels is based on a generic section as shown. It can be used with small error for all sections commonly marketed for wall panel use.

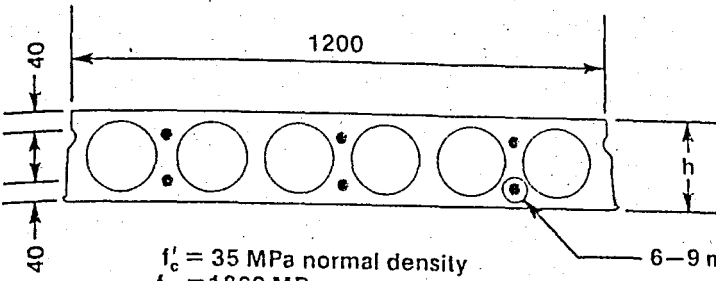

h (mm)	Interaction curve data			
	ϕP_o	ϕP_{nb}	ϕM_{nb}	ϕM_o
200	2270	700	108	36
300	3070	900	208	59

Curves shown for full development of strand

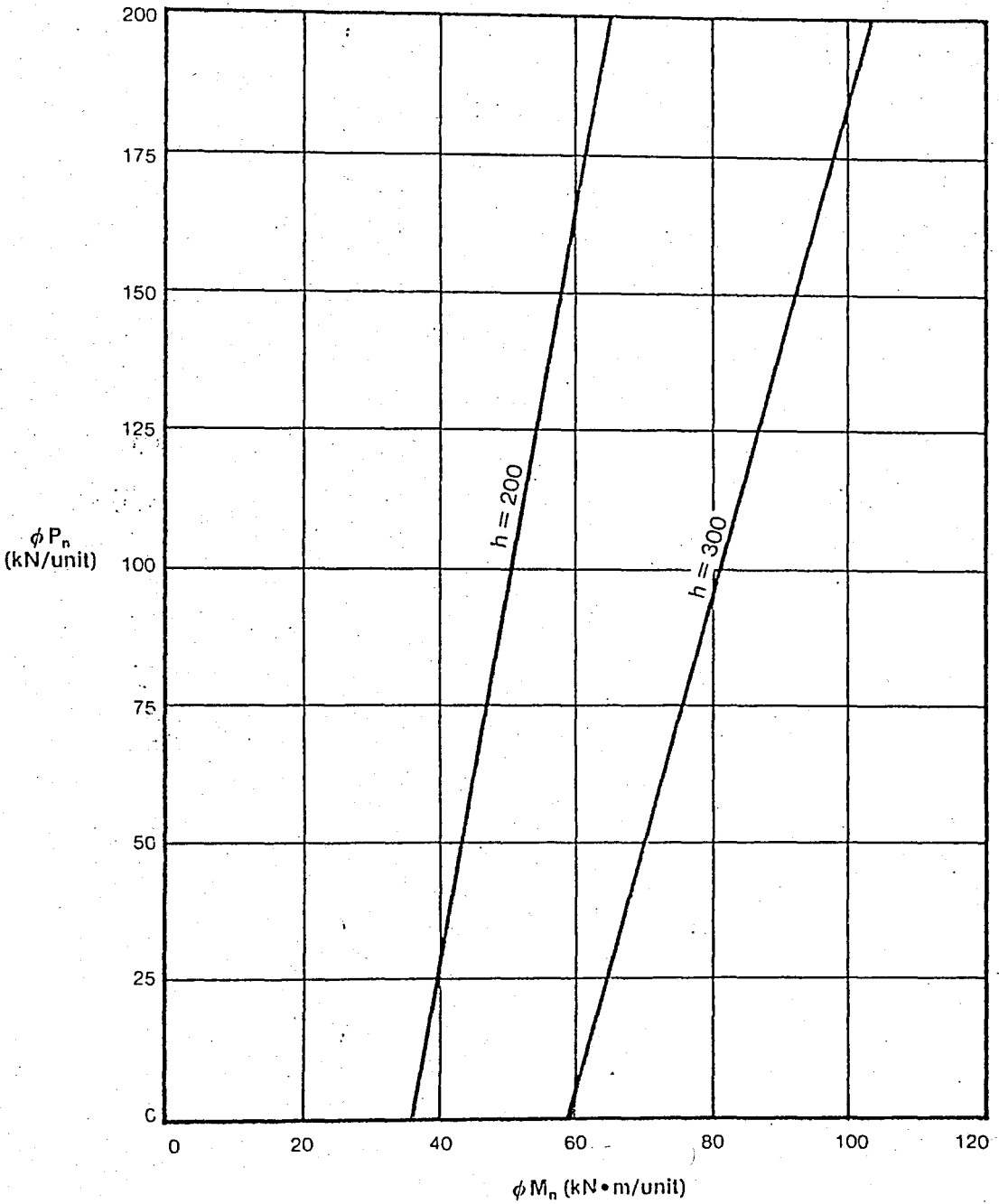

Fig. 14 Partial interaction curve for prestressed hollow-core wall panels

V- DESIGN OF CONNECTIONS

This section presents concepts of analysis and equations for design of connections for various types of connections as slab to slab, slab to beam, slab to wall, and also typical beam to column details.

5.1. Criteria for Connections

Connections must meet a variety of design and performance criteria, and not all connections are required to meet the same criteria. Some of the items discussed in this section are self evident. Other requirements may not be so obvious and may require special consideration or specification by the designer.

Resistance

A connection must resist the forces to which it will be subjected during its lifetime. Some of these forces are apperent, caused by dead and live gravity loads, wind, earthquake, etc. Others are not so obvious and are frequently overlooked. These are the forces caused by restraint of volume changes in the elements and forces required to maintain stability. The connection resistance can be categorized by the types of force that may be induced. These include:

- a) Compression
- b) Tension
- c) Flexure
- d) Shear
- e) Torsion

Many connections will have a high degree of resistance to one type of force, but little or no resistance to another. For example a connection may have a high shear capacity and little or no moment capacity. It may be unnecessary, or even undesirable to provide a high capability to resist certain types of forces.

Ductility

Ductility is usually defined as the ability to accommodate relatively large deformations without failure. In structural materials, ductility is usually measured by the amount of deformation that occurs between first yield and ultimate failure. Ductility in building frames is usually associated with moment resistance. This is particularly true in designing for earthquake forces, where concerns over ductility are usually expressed.

Volume Change Consideration

The combined shortening effects of creep, shrinkage and temperature drop can cause severe stresses on all types of precast, prestressed concrete elements, if the end connections restrain movement. These stresses must be considered in the design, but it is usually for better if the connection will allow some movement to take place, thus relieving the stresses.

Most of the severe problems that have been caused by restraint of volume change movements have appeared when relatively long elements, usually stemmed deck units, were welded to their supports at the bottom on both ends. When such elements are connected only at the top, volume changes are adequately accommodated. On relatively short, heavily loaded elements, such as beams, an unyielding top connection may attract negative moments that are difficult to accommodate.

5.2. Connection Design of Slab to Slab

Hollow core slab elements transfer the in-plane shear forces from one to another, by means of the resistance along their longitudinal keyways. The strength and capacity of the keyway is dependent on shear strength of the grout, as well as on the existence of the topping. This is the standard connection used between hollow-core and solid slabs. The size and shape of the key vary with the method of manufacture. The key is usually filled with a sand-cement grout. This connection distributes vertical loads and provides horizontal shear transfer for moderate loads when the deck is used as a diaphragm.

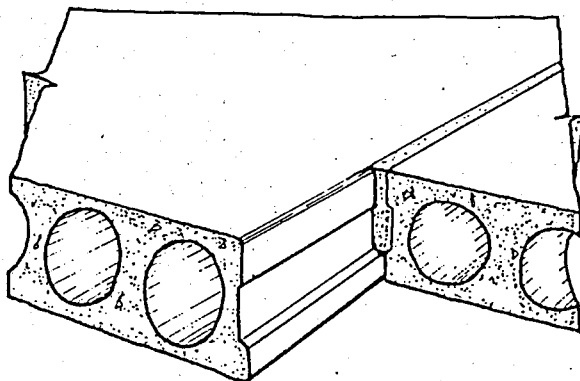

Fig. 15 Typical slab to slab connection

The Turkish Earthquake Code does not specify any particular capacity for the unreinforced grout and topping, but, one can select the maximum shear capacity of a low quality concrete to be on the safe side. For instance, the ultimate shear strength is specified as $\tau = 0.17\sqrt{f'_c}$ where f'_c is specified compressive strength of concrete which, results in $\tau = 0.68$ N/mm² for BS16, and $\tau = 0.76$ N/mm² for BS20. The allowable shear stresses, for the same quality concretes, by TS500, are $\tau = 0.55$ N/mm², and $\tau = 0.60$ N/mm² respectively.

The Uniform Building Code, specifies the maximum strength of a grout as $\tau = 0.56$ N/mm² which is very good harmony with the above values.

The strength of a unreinforced grout is tested in the following manner:

$$F_d \leq \phi F \quad \text{where,}$$

F_d = calculated shear force with load factors

$$\phi = 0.85$$

$$F = \tau \cdot d \cdot l$$

d = height of grout plus topping, if any

l = length of grout for shear force, V_u

If the grout is not sufficient to carry the shear force, reinforcing bars, or special fasteners should be utilised. The cross-sectional area of the reinforcement is obtained from.

$$A_{ds} = F_d / (\phi f_y)$$

Usually, the reinforcement placed in the butt joints at hollow core slab ends, will provide effective resistance against such longitudinal shear.

As an alternate method, the hollow core slabs may be connected to each other by means of U-shaped reinforcing bars, or welded steel plates along the longitudinal joint as shown in Fig. 16 (ref. -5). However, steel connections along the longitudinal joint are relatively more expensive than the reinforcement along the butt joint.

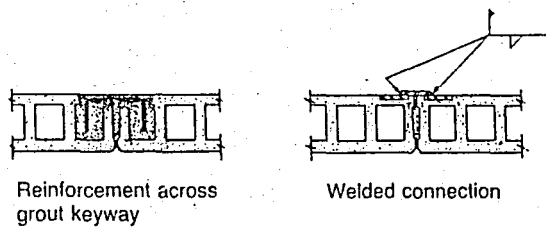

Fig. 16 Alternate longitudinal shear connections

5.3. Connection Design of Slab to Beam

When there are multi-bay arrangement, as shown in Fig. 17, it is necessary to design that, the horizontal connection along the beam line, should resist the acting shears, V_u . The acting shear for the beam line of the upper bay, is calculated in one of the following two methods :

Diaphragm Action technique

Assuming the right hand side supports as rigid, since they are restrained against shear forces, and following the instructions described in the chapter before, the shear force V_u can be obtained from

$$V = T = \frac{F.L}{8jh} \quad \text{in which,}$$

F = Lateral earthquake force of the slab segment in question
 L = length of diaphragm span
 h = Width of slab segment in question
 j = Moment level arm ratio in a beam cross-section.

It should be noticed that the valid length of the shear force V_u is $L/2$ which is one half of the span length of the diaphragm.

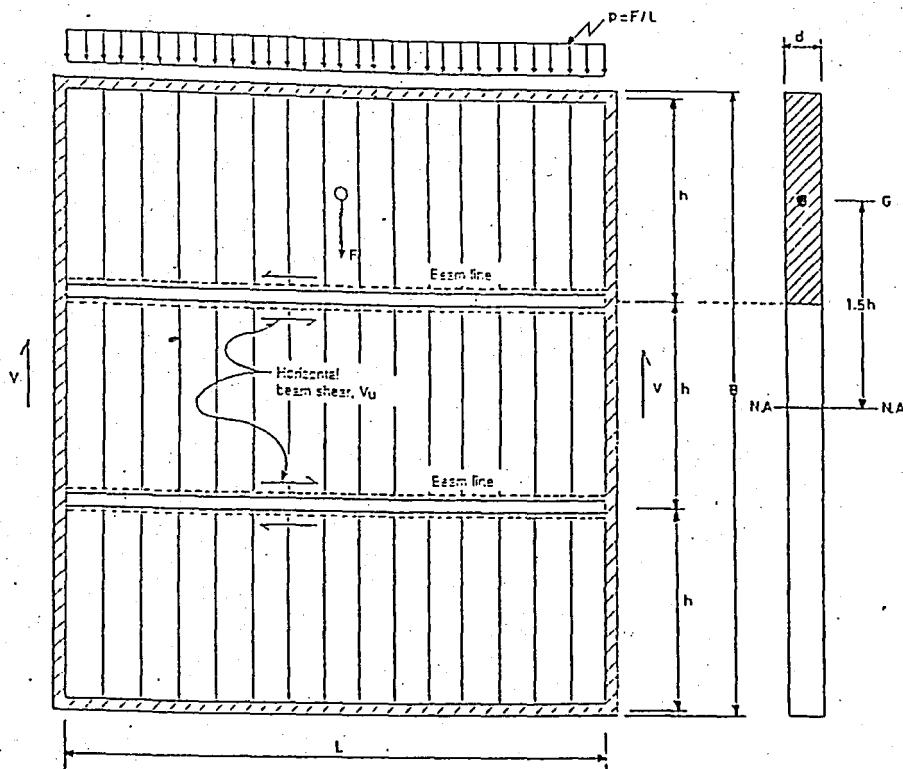

Fig. 17 Multi-bay slab arrangement

Flexural Shear Action Technique

Assuming the entire slab diaphragm, $B \times L$, as a deep beam, and using the expression for the calculation of the horizontal flexural shear in a beam, the shear force per unit distance, V_u , along the horizontal beam, may be obtained from

$$\tau = V.Q / I.b \quad V_u = \tau_{u.b} \quad V_u = V.Q / I \quad \text{where,}$$

V = Shear force of the diaphragm beam at the point where V_u is required.

Q = Static moment area of the part of the cross-section of the diaphragm above the beam line in question.

I = Moment of inertia of the cross-section of the complete diaphragm.

Assuming a diaphragm thickness of d , and referring to Fig. 18

$$V = F/2 \text{ (maximum at support)}$$

$$Q = 1.5 h^2.d$$

$$I = d B^3/12$$

In the light of the procedures explained, the necessary reinforcement can be determined from the same way described in section 5.3.

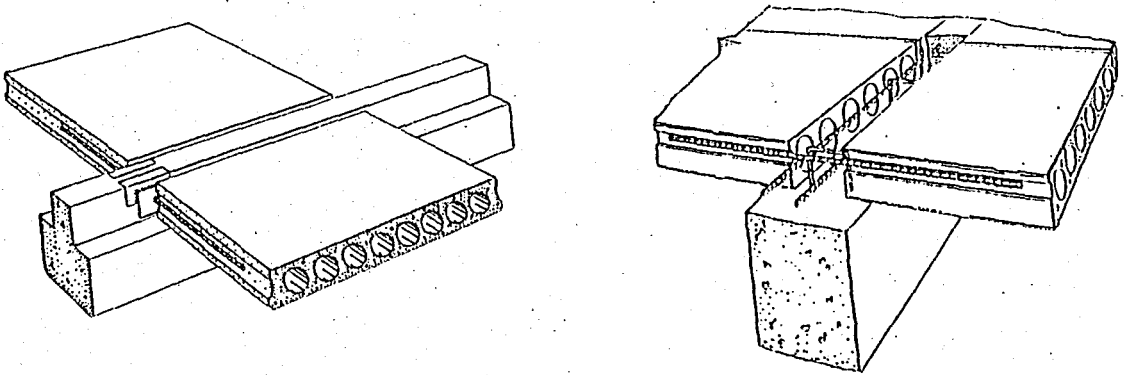

Fig. 18 Typical slab to beam connections

The design of all slab-to-beam connections, whether for floors or roofs, should consider the effects of volume changes and the transfer of horizontal forces from the slab to the beam when the floor or roof is assumed to act as a diaphragm. Movements at the connection between roof slabs and beams may damage the roofing, thus a special expansion detail should be considered. On floors with cast-in-place topping, additional mesh or reinforcement should be placed across the beam to minimize cracking.

a) This detail shows one way to develop diaphragm action at a beam in a hollow-core roof system if friction is not sufficient to transfer the lateral forces and thus a positive connection is required. Plates are cast into the upper portion of the ledger beam and welded deformed stud bars extend into the grouted joint between slabs. Erection considerations may dictate a different detail, such as having the beam top lower than the tops of the slabs to allow for placement of continuous reinforcing bars in slab keyways. Details should be limited to those recommended by the local producers as long as they are consistent with the design requirement. Floors with topping usually do not require any additional connection to the beam.

b) This connection provides a positive integral floor system without welding or cast-in-place topping. With projecting stirrups as shown, the cast-

in-place top portion of the beam acts compositely with the precast section, providing added structural capacity

5.4. Connection Design of Slab to Wall

Horizontal joints in load bearing wall construction occur at floor levels and at the transition to foundation or transfer beams. Depending on function of walls, these joints connect floors and walls or wall units only. The principal forces to be transferred are vertical and horizontal loads from panels above and from the diaphragm action of floor slabs. The resulting forces are : (a) normal to joint-compression or tension; (b) horizontal to joint-horizontal shear; (c) vertical to joint at face-vertical shear; (d) perpendicular to joint-compression or tension from floor to diaphragm Fig. 19 (Ref. 8).

Considering the limited frame action that can be developed perpendicular to a wall, moment stresses in the joint are normally only of minor importance.

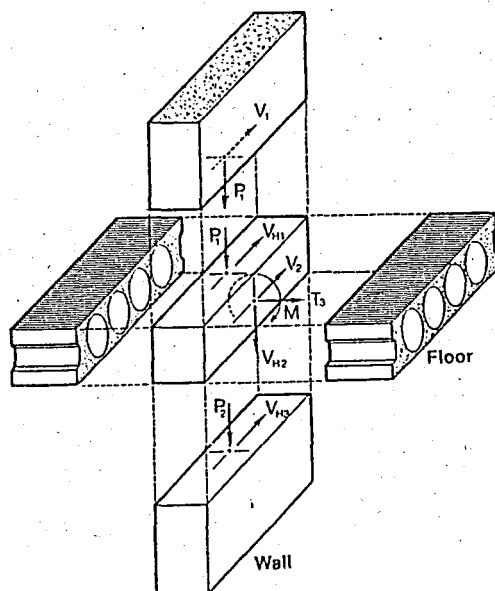

Fig. 19 An interior floor to wall connection

It should be noted that any tension force in the joint has to be transferred into the wall panels by appropriate connection and tie details. Horizontal shear forces from the floor diaphragm action or direct lateral loads are resisted by (or combinations of) the shear strength of the grout,

friction, or shear-friction. Since shrinkage or structural movements may create a crack at the wall-grout interface, the lesser of the friction, shear resistance or shear friction resistance should be used in design.

The horizontal shear resistance can be determined by :

$$\phi V_{nh} < P_d \cdot \mu \text{ (friction) , } \phi V_{nh} \leq \phi V_{cg} \cdot t_g \cdot l \text{ (shear)}$$

Where

P_d = Vertical dead load

μ = 1.0 for roughened surfaces ; 0.60 for smooth surfaces

ϕ = 0.70

V_{cg} = Grout shear strength $\leq 0.2 f'_{cg}$ and $\leq 60 \text{ kg/cm}^2$

f'_{cg} = Compressive strength of grout concrete.

To develop horizontal force through friction, a normal force must be present. This normal force can result from imposed loads (without load factors), from reinforcing steel crossing an assumed crack, or from post-tensioning forces. When the equivalent of a normal force is provided by reinforcing steel, the area of steel can be calculated by shear friction :

$$A_{vf} = V_{uh} / \phi \cdot f_y \cdot \mu_e \quad \text{where;}$$

$$f_y = \text{yield strength of steel but } \leq 4 \text{ t/cm}^2 \quad \phi = 0.70$$

This shear-friction reinforcement should be uniformly distributed along the assumed length of crack and adequately anchored into the panels.

The details show some of the combinations of slabs supported by walls. Also shown is the connection of a roof slab to a paralelel wall. In most designs some degree of continuity is required at the slab-to-wall connection.

a) This detail represents a typical installation of hollow-core slabs on masonry walls. A bond beam is provided directly under the slabs, and the joint between the ends of slabs is grouted full. In multi-story construction, it is necessary to insure that the ends of the slabs can transmit the vertical compressive forces. In multi-bay construction, consideration must be given to the forces developed due to restraint of volume changes.

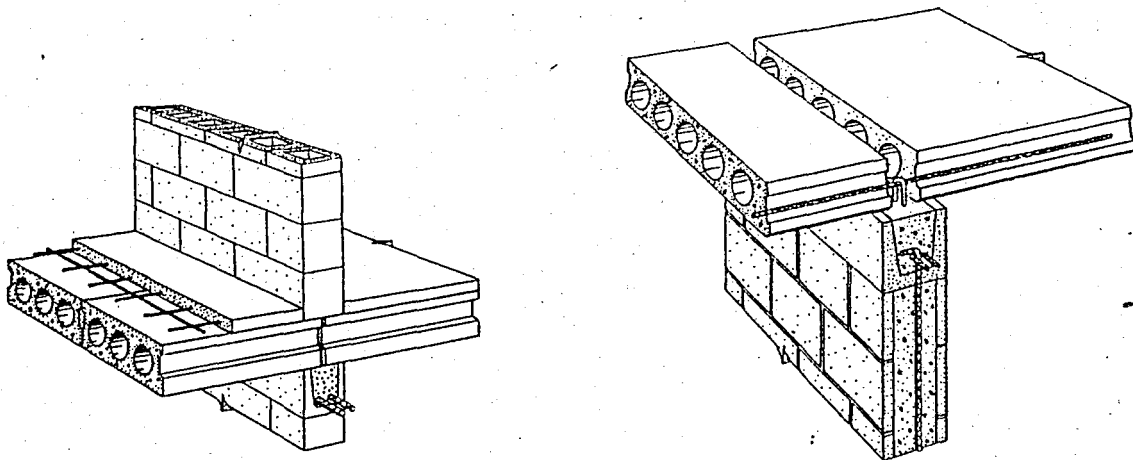

Fig. 20 Typical slab to wall connections

b) In this detail positive anchorage of the hollow-core units to the wall is accomplished by inserting hairpin bars into the bond beam and embedding them in the grout closure between the slab ends. If required, L-shaped bars are cast into the bond beam and into mortar filled cores of the block as shown in order to transfer forces into the wall. For positive roof diaphragm action, or when topping is not used on floors, a reinforcing bar can be grouted into the keyways between hollow-core slabs. This bar also serves to tie the slabs together, preventing roofing problems at the joint.

5.5. Typical Beam to Column Details

Connection types BC-1 through BC-7 are a few of the connection combinations used for beams to columns. For simplicity, all the beams shown are rectangular, although they could be ledger beams, I-beams, or single tees.

BC-1- This detail conceals a corbel or haunch without using a dapped-end beam as shown in BC-3. Confinement angles and/or bearing pads may be required by the design. The detail shown is for a simple span condition. It can also be used for a moment connection by using non-shrink grout between the end of the beam and the column and by providing for transfer of tension at the top of the beam.

BC-2- This is a variation of BC-1 with the reinforced concrete haunch projecting from the column. It is shown with an elastomeric bearing

pad and plates in both the haunch and the beam. As with BC-1, this detail is shown for a simple span condition, but it can be developed into a moment connection if required. Bearing pads are optional, according to design requirements.

BC-3- This detail is often referred to as a dapped-end connection, and usually requires confinement angles because of high stresses. To develop this detail into a moment connection requires non-shrink grout at two different interfaces, which is a difficult field procedure. Placement of reinforcement in this detail is probably the most critical of all the beam-to-column details shown; at no place should an unreinforced shear plane occur between the connection reinforcement and the main flexural steel.

BC-4- This detail is often used when it is desired to hide the beam-to-column connection. Shown is a wide flange section projecting from the column. Other embedded structural steel shapes may be used, such as T-beams, double channels or double plates. Again, like BC-3 the dapped beam requires care in detailing and placing the reinforcement. Closely spaced ties should be placed in the column immediately above and below the embedded structural steel shape.

BC-5- This is a dowelled connection with bars projecting from the column into conduit or steel tubes cast into the beam. The tube is then grouted full. To prevent restraint against volume change rotation, vermiculite, sand or other loose material may be placed in the bottom of the tube before grouting. In freezing weather it is important to prevent water from entering the tubes prior to grouting. Bearing pads, steel plates or confinement angles are used at the bearing surfaces. The connection can be made continuous by providing welded or lapped tension reinforcement similar to that shown in BC-6. Tension bars can also be placed in topping or in blockouts in the tops of the beams.

BC-6- This detail is a moment connection variation of BC-5 achieved by welding reinforcing bars to angles. It has the advantage of allowing for future extension of the column by placing anchor bolts or inserts in the cast-in-place concrete between the ends of the beams. When this is done, tied column bars should extend into the cast-in-place closure from the column below.

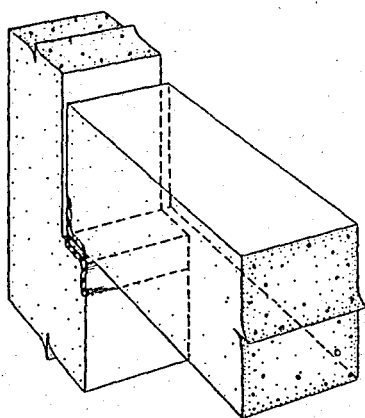

BC-1

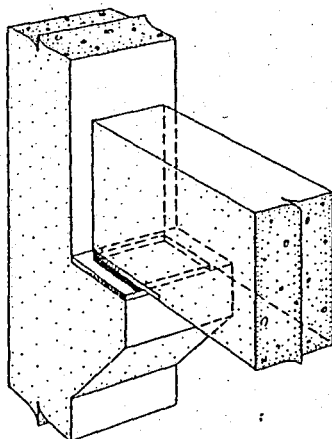

BC-2

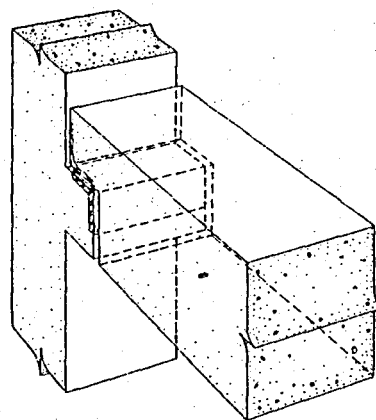

BC-3

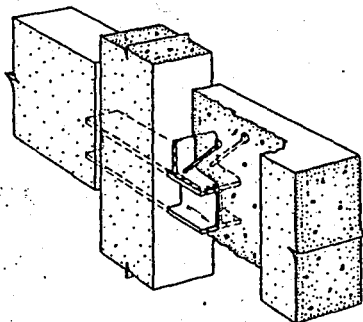

BC-4

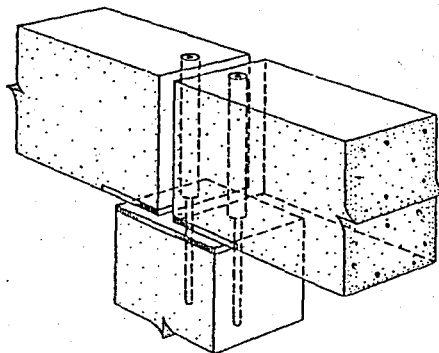

BC-5

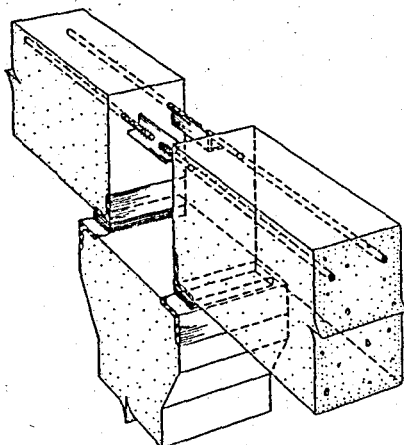

BC-6

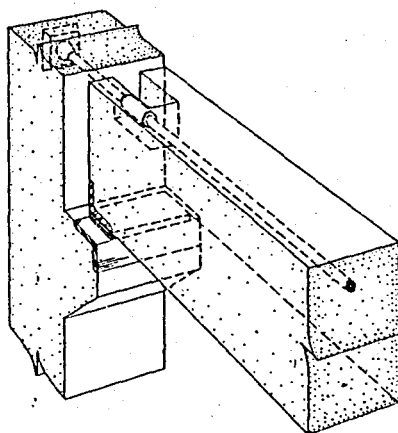

BC-7

Fig. 21 Typical beam-to-column connections.

BC-7- This detail shows a straight post-tensioning bar which is tensioned following placement of the non-shrink grout between the column and the beam end. This requires a good mechanical anchorage to prevent loss of post-tensioning stress due to seating or slippage. It also requires proper placement of confinement ties to prevent excessive bearing stress under the end anchorage. The tendon may also be curved and anchored at the bottom of the beam, or be made continuous throughout the beam.

VI- ANALYSIS AND DESIGN OF HOLLOW CORE SLABS

6.1- Under Horizontal Loads

As a floor or roof deck, a hollow core slab system can be readily used as a horizontal diaphragm to resist lateral loads in addition to carrying vertical loads. However, additional elements are required to complete the lateral load resisting system.

In resisting lateral loads, the basic consideration is to transfer the lateral load from the point of application of the load to the foundation system. Several design elements are in this load path and each element must be capable of accepting the load, carrying the load to the next element in the load path, and transferring the load into the next element. As seen from Figure 22, for lateral load in the direction shown, hollow core wall panels 1 and 2 must have the flexural capacity to span between the foundation and roof when subjected to the lateral load. The connections of the wall panels must have the capacity in tension or compression to transfer the bottom and top wall panel reactions to the foundation and the roof. The hollow core roof, as a diaphragm, must have the shear and flexural capacity to span as a horizontal beam to the shear walls, 4 and 5, which provide the reactions for the diaphragm. The connections of the diaphragm to the shear walls must be capable of transmitting the diaphragm reaction in shear to the shear walls. Finally, the shear walls must have the member strength and adequate connections to transmit the shear from the roof elevation down to the foundation. This section will present criteria for design of a hollow core slab system used as the diaphragm portion of the lateral load resisting system. The design information is based on the completed structure. During erection, temporary measures may be required for erection stability.

6.1.1. An Overview of Earthquake Code Requirements

Initially, prestressed and precast elements were limited to low rise

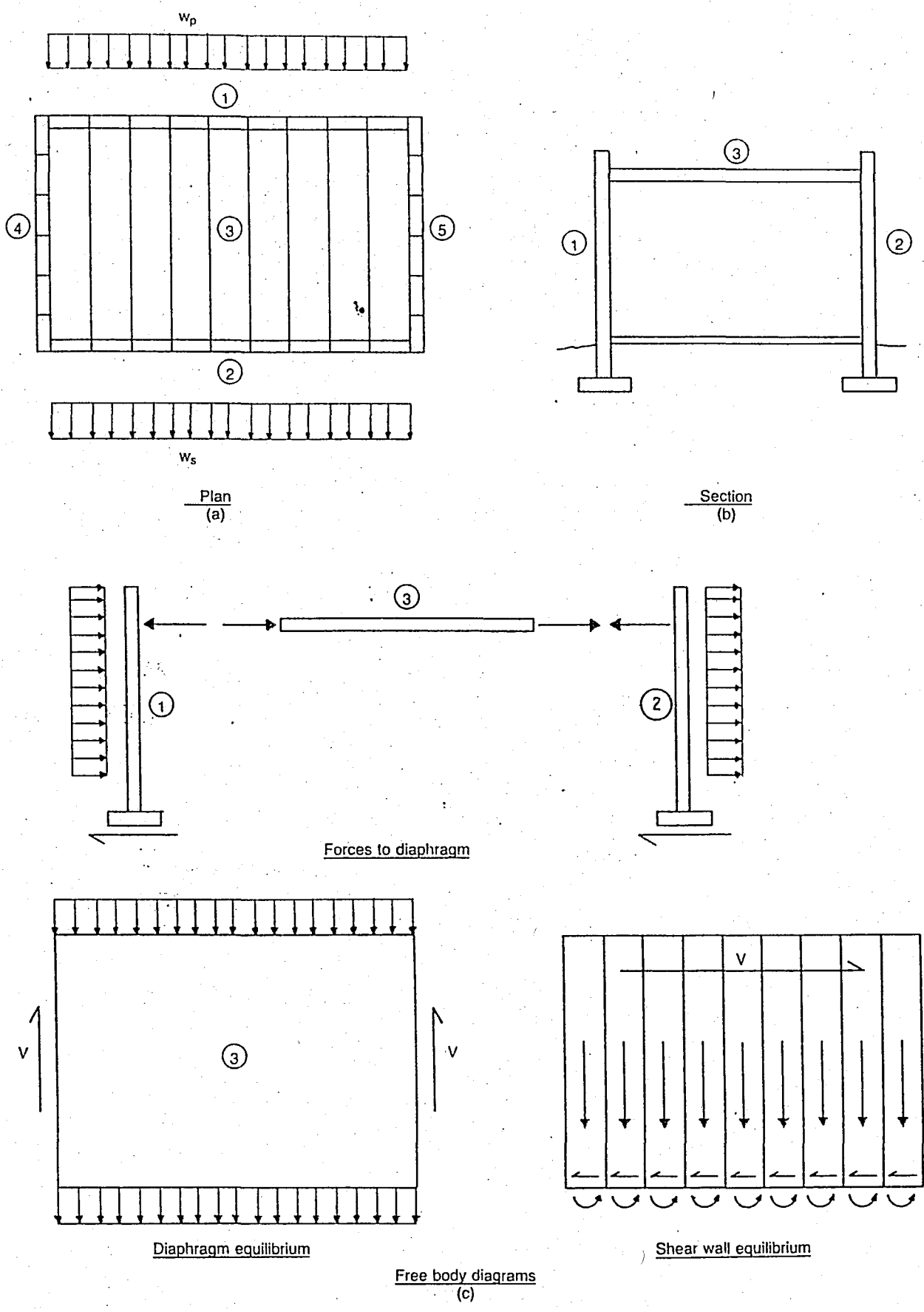

Fig. 22 Elements of a lateral load resisting system

panel structures. But, the volume of construction of prefabricated multi-storey structures have been increased, especially in Japan and Eastern Europe in the last two decades.

Although, there is some conservatism in Turkey to accept a widespread application of prefabricated structures, there has been a major advancement in this field, also in the last few years. There are, however, only a few specific provisions in the Turkish Earthquake Design Code (Ref. 1), regarding the design principles prestressed for and precast structures. In the absence of any specific design requirement in the Turkish code, fortunately, one may consult the seismic code provisions of other countries, like Japan and USA, in which the design concepts and requirements are clearly documented and well established for prestressed and precast structures.

6.1.1.1. Turkish Earthquake Code

For The Building as a Whole

The base shear coefficient recommended by the current Turkish Earthquake Code is as follows :

- $C = C_0 \cdot K \cdot S \cdot I$ in which,
- C_0 = Risk zone factor, as 0.10, 0.08, 0.06 and 0.03 for zones 1, 2, 3 and 4 respectively.
 - K = Structural factor varying from 0.6 to 1.50. For all one and two storey buildings, minimum value of K is 1.
 - S = Soil-structure interaction factor which is determined by ;
 - $S = 1 / (0.8 + T - T_0)$ where;
 - T = Fundamental period of vibration of the structure, in the first mode, sec.
 - T_0 = Predominant period of vibration of the underlying soil, as 0.25, 0.42, 0.60 and 0.80 sec, for soil conditions, equivalent to rock, hard clay, medium clay, and soft silty clay, respectively.
 - $S = 1$ for all one and two storey structures, for all masonry structures of all heights and also maximum value for all buildings.

I = Importance factor, normally as 1.0, but for the buildings people exist very much as 1.50.

For Precast Elements

It is important to notice that no requirements are specified in the Turkish Earthquake Code, regarding neither the design of precast non-bearing non-shear wall panels nor their connections and fasteners. Hence, it would be very useful to review the earthquake design provisions of the Uniform Building Code, especially pertaining to the precast elements and their connections.

6.1.1.2. Uniform Building Code

For The Building As a Whole

The base shear coefficient recommended by the 1979 Uniform Building Code (Ref. 3), is given by

$$C = Z.C_0.K.S.I \quad \text{in which}$$

$$C_0 = 1 / 15\sqrt{T} \leq 0.12$$

$$Z = \text{Zone factor, specified as } Z = 1, 0.75, 0.375 \text{ and } 0.1875 \text{ for earthquake risk zones 4, 3, 2 and 1 respectively.}$$

$$K = \text{Structural coefficient varying between } 0.67 \text{ and } 1.33$$

$$S = \text{Soil-structure coefficient}$$

$$S = 2.3 + 0.6a - 0.3a^2 \quad \text{for } a > 1$$

$$S = 1.0 + a - 0.5a^2 \quad \text{for } a \leq 1 \quad a = T / T_0$$

If, T_0 = Soil predominant period, can not be properly defined, it is recommended to take $S = 1.5$. In no case however, the product $C_0.S$ should exceed 0.14.

For Precast Elements

For a particular component of the structure, or for any particular precast element, the lateral earthquake load efficient is,

$$C = Z.C_p.I \quad \text{in which, } C_p = 0.3 \text{ for most precast concrete}$$

components and their connections. There are certain rules for calculating the design forces of the precast elements as follows:

- 1- The body of a precast connection for non-bearing non-shear wall panel is required to resist a seismic lateral load obtained by using $C_p = 0.40$.
- 2- Fasteners attaching the connector to the panel, or the elements such as bolts, inserts, welds, or dowels are required to resist a seismic lateral load obtained by using $C_p = 1.20$.
- 3- Connections and panel joints should also allow for a relative movement between stories of the greater of 1.27 cm, two times the storey drift caused by wind or $3/K$ times the calculated storey displacement caused by seismic forces.
- 4- Precast members and connections of a braced steel frame in buildings located in Seismic Zones No. 3, and No. 4, buildings located in Seismic Zone no. 2 with an importance factor, I , greater than 1.0 are required to resist a seismic force, utilizing 1.25 times the C_p values recommended above.

It is seen from the above rules of the UBC (1979) that, the precast elements are designed to resist a statically equivalent seismic force of

$$C = 1.25 \cdot Z \cdot C_p \cdot I$$

From the view point of the rules and the procedures described above, the seismic force is calculated by

$$F = C \cdot W$$

in which, W = Weight of the precast component under consideration. These load coefficients, varying from 37.5 percent to 150 percent, are really very stringent requirements for the connection design of precast slab and wall elements. It is hoped that, similar provisions are incorporated in the future versions of the Turkish Earthquake Code, since there has been a widespread utilisation of precast slab and wall elements in the construction of multistorey buildings in Turkey, recently.

6.1.2. Assumptions In Diaphragm Design

Hollow core slabs may be used effectively to produce a diaphragm either with or without a composite structural topping depending upon local building codes. If used without a structural topping, connections must be provided to accept a lateral load and to transmit the load to the vertical bracing element. The diaphragm must also have structural integrity in shear and flexure to span as a horizontal beam between lines of support.

Diaphragm design involves determination of the forces to be resisted by the diaphragm and developing the mechanism to get forces out the diaphragm. Equilibrium can then be determined for the system. The following assumptions are made for the purpose of solving this force determination problem.

For only the purpose of distribution of forces to vertical elements, the hollow core slab elements (diaphragm) is normally assumed to be infinitely rigid. Vertical elements will then be designed to resist forces in the diaphragm, in proportion to their stiffnesses. However, the design of connections of the diaphragm itself follows an opposite path, and hence the shear forces are usually based on the principle of a flexible deep beam seated on infinitely rigid vertical elements. Such a dual assumption is widely used throughout the world and resulted in no particular problem, since all the forces and shears calculated on this basis, are on the safe side.. More refined and sophisticated techniques and procedures, involving consideration of the stiffnesses of both the diaphragm vertical element, and the use of finite element method, would be rarely justified.

The lateral loads to be used for the design of a given diaphragm will vary from level to level depending on its location vertically in the building. The design load is based primarily on the maximum horizontal acceleration that is calculated for that particular level in the building, with minimum values prescribed by Code. Changes in stiffness of shear elements directly above and below the diaphragm must be considered in the design. The loads assumed by the codes for diaphragm design are rather approximate. Such things as openings and frame or shear wall stiffnesses have

an effect on the distribution of loads. Thus, design refinements are not warranted, and simplifying design assumptions are normally used. The following principals should be considered in the analysis and design of hollow core diaphragms :

- 1- There must be sufficient shear strength between hollow - core slab elements to act as an integral structural beam web; enough perimeter (flange) reinforcement to develop flexural tension; and adequate connections to transfer shear to the shear walls or frames. Perimeter bars in the frame or shear wall may be used as flange reinforcement.
- 2- Struts may be required between shear walls or frames to distribute forces to the diaphragm, to transfer forces between vertical shear elements, or to redistribute forces around openings in the floor diaphragm. Cast-in-place concrete pour strips may be used for this purpose if mechanical fasteners can not handle the forces.
- 3- The diaphragm is usually assumed to be an infinitely stiff element for analysis of the load distribution between the shear elements. Diaphragm deflections are normally very small and most are caused by shear deformation rather than flexural deformation. However, if the diaphragm has substantial flexibility these deflections should be added to the story drifts contributed by the shear frames or walls.
- 4- Horizontal torsion resulting from the center of mass being eccentric to the center of rigidity must be included in the design. Most codes and also The Turkish Earthquake Code require that, five percent of the longest plan dimension is the minimum eccentricity to be considered.
- 5- Shear transfer of the hollow core diaphragm with topping is dependent on the bond of the topping to the precast element. Diaphragm systems without topping must transfer these generated forces through mechanical connections or continuous pour strips. Mechanical connections cause stress concentrations which may result in local failure under the possible peak load conditions. This may be avoided by reducing the allowable stresses used for design of the connections and thus increase the

elastic capacity. Continuous pour strip connections result in a more uniform stress distribution, but are much more costly.

- 6- Interior bearing walls and slab openings tend to disrupt diaphragm continuity. Additional reinforcement may be required in these areas.
- 7- Earthquake loads may be induced into a diaphragm from any direction. The diaphragm and its connections should be designed for the most critical loading direction.

6.1.3. Analysis of Diaphragm Action

Based on the assumptions to be taken into account described, the peripheral shears, chord forces and stresses of a diaphragm in the form of a deep beam, may be calculated for various support conditions, as follows:

TYPE 1- Simple Beam Action

(Lateral rigid supports are at the ends)

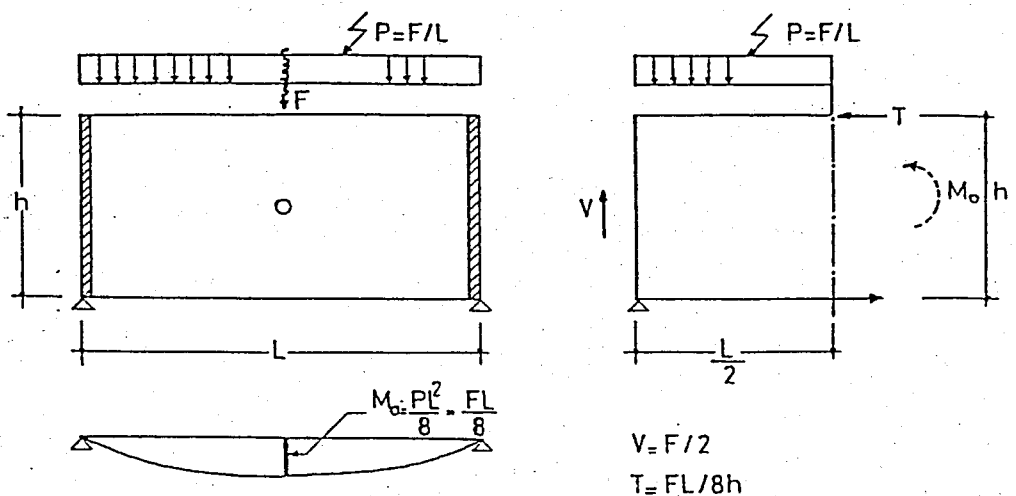

Fig. 23 Simple Beam Action Type 1

Calculation of shear forces along the periphery :

$$V = F/2$$

$$T = F.L/8.h$$

$$V = \text{Shear along the lateral support}$$

- T = Resultant chord force along the longitudinal side of diaphragm, either in tension, or in compression.
- F = Lateral earthquake or wind load acting on the diaphragm
- F = C.W (earthquake)
- F = p.L (wind)
- C = Earthquake lateral load coefficient at the storey concerned
- W = Weight of the diaphragm
- p = Uniform wind load acting on the diaphragm
- L = Span length of diaphragm
- h = Depth of diaphragm
- j = Ratio of moment lever arm in a beam cross-section varying diaphragm to 2/3 for a from 1.0 for flanged diaphragm to 2/3 for a diaphragm without flanges.

The support shear value V is valid along the entire diaphragm height. Similarly, the resultant chord force T , is assumed to be valid along one half of the diaphragm span length.

The cord force T , should be normally calculated using $T = M/jh$ where, j , represents the ratio of lever arm distance between the centroids of compressive and tensile stress areas. Walls, spandrels, or beams when resisting tensions, or compressions resulting from diaphragm bending moments, may be regarded as flanges of the diaphragm. Therefore, in order to account for flanges, the above expressions for calculation of T , should be divided by the appropriate value of j .

TYPE 2- Cantilever Beam Action

(Lateral supports are at three sides)

Maximum shear force along the support V , as well as the resultant chord force along the longitudinal side of the diagram, T , are calculated as:

$$V = F$$

$$T = FL / Zjh$$

The variable shear force at any particular distance x , from the support, f unit length is

$$T = P (L-x)^2 / 2h$$

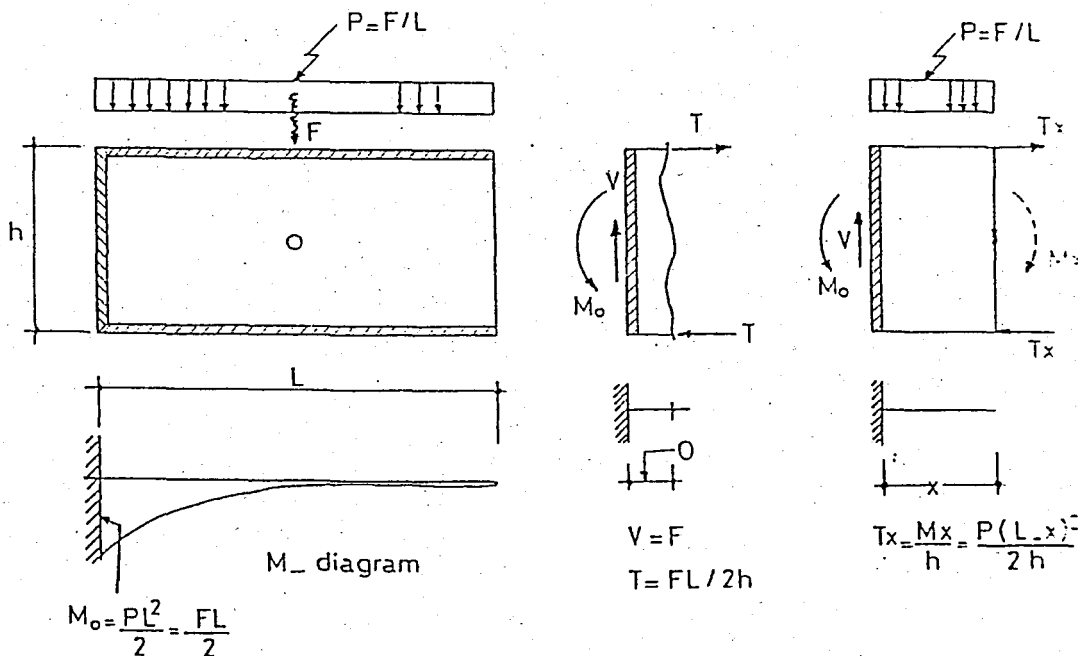

Fig. 24 Cantilever Beam Action Type 2

in which, $p =$ the uniform wind load. If however, the lateral load is seismic load, an equivalent uniform load value, $p = F/L$ should be used. In cantilever beam action, the right hand side of the diaphragm, is assumed as free, even though that it may be vertically supported. Simply because there is no shear resistance along this edge. If, a vertical support does not provide any resistance against in-plane shear forces such a line is regarded as a free support line, for the purpose of diaphragm action only.

6.2. Under Vertical Loads

As with prestressed concrete members in general, hollow core slabs are checked for prestress transfer stresses, handling stresses, service load stresses and design (ultimate) strength in both shear and flexure. After these controls it is necessary to check the cambers if they are within the limits specified by the codes.

In this section, Flexure resistance at ultimate limit state, Flexural design at service limit state, Shear design, and finally camber and deflection check considerations will be described to find out the moment capacity of the section, the stresses in concrete and prestressed reinforcement, shear

reinforcement if necessary and to determine camber.

6.2.1. Flexural Resistance at Ultimate Limit State

The moment capacity of a prestressed member is a function of the ultimate stress developed in the prestressing strands. As with non prestressed concrete, upper and lower limits are placed on the amount of reinforcing to ensure that the stress in the strands is compatible with concrete stresses for ductile behavior. The flexural resistance of an element must meet the requirements :

$$M_u < \phi M_n \text{ and } \phi M_n > 1.2 M_{cr} \quad \text{where}$$

M_u = Factored moment at a section
 M_n = Nominal flexural resistance of a section $\phi = 0.90$
 M_{cr} = Cracking moment under combined moment

The nominal resistance of a section is based on the solution of the equations of equilibrium, normally using the rectangular stress block. For prestressed elements, the steel stress at nominal resistance (f_{ps}) can be determined either by the approximate equation given in ACI (318-83) Code and Turkish Code TS 3233 or by a strain compatibility analysis.

For elements with compression reinforcement, the nominal resistance can be calculated with little error by assuming that the compression reinforcement yields, which may not actually be the case. For design of elements, a section and reinforcement will normally be chosen and the factored resistance computed and compared with the factored moment. If necessary, the reinforcement and/or section is revised and the factored resistance recalculated. A flow chart illustrating the application of design calculations for the computation of the nominal resistance of flexural elements is given in Fig.27

Stress Block

The equations for nominal flexural resistance given in below figure apply only to rectangular cross sections. To derive the depth of the stress block "a", divide the first equation of equilibrium by bdf_c giving :

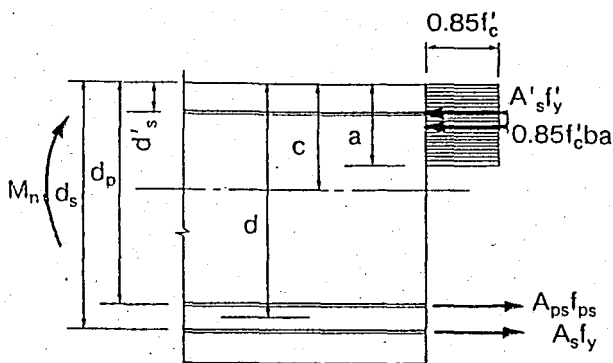

For equilibrium at nominal resistance:

$$0.85 f'_c b a = A_{ps} f_{ps} + A_s f_y - A'_s f'_y$$

$$\bar{\omega} = \frac{A_{ps} f_{ps}}{b d f'_c} + \frac{A_s f_y}{b d f'_c} - \frac{A'_s f'_y}{b d f'_c} = \omega_p + \omega - \omega'$$

$$M_n = f'_c b d^2 \bar{\omega} (1 - 0.59 \bar{\omega}) + A'_s f'_y (d - d'_s)$$

$$\text{or } M_n = A_{ps} f_{ps} (d_p - a/2) + A_s f_y (d_s - a/2) - A'_s f'_y (d'_s - a/2)$$

Fig. 25 Nominal flexural resistance (Ref 8)

$$\frac{0.85 f'_c b a}{b d f'_c} = \frac{A_{ps} f_{ps}}{b d f'_c} + \frac{A_s f_y}{b d f'_c} - \frac{A'_s f'_y}{b d f'_c} = \bar{\omega} \quad \text{in which,}$$

$\bar{\omega}$ = $\omega_p + \omega - \omega'$ (reinforcement percentage index)

A_{ps} = Area of prestressed reinforcement

A_s = Area of non-prestressed tension reinforcement

a = Depth of equivalent rectangular stress block

b = Width of compression face of element

c = Distance from extreme compression fibre to neutral axis

d = Distance from extreme compression fibre to centroid of tension reinforcement

f'_c = Specified compressive strength of concrete

f_y = Specified yield strength of non-prestressed tension reinforcement

f'_y = Specified yield strength of non-prestressed compression reinforcement

Therefore, $a = 1.18 \bar{\omega} d$. If $a > hf$ (flange thickness), the force F_1 required to develop the compressive strength of the overhanging flanges is deducted from the total force in the tension reinforcement in order to determine the flexural resistance component of the web as shown in the flow chart, fig. 27.

For the ductility requirement of the section, the lower limit of reinforcing requires that : $\phi M_n > 1.2 M_{cr}$

$$M_{cr} = \left(\frac{P}{A} + \frac{P \cdot e}{S_b} + 0.6 \sqrt{f'_c} \right) S_b \quad \text{where,}$$

M_{cr} = Cracking moment under combined loading

P = Prestress force after losses

A = Cross-sectional area

e = Eccentricity

S_b = Section modulus with respect to the bottom fibre of a cross section

f'_c = Specified compressive strength of concrete

6.2.1.1. ACI (318-83), TS 3233 Code equations

A conservative method for determining the value of stress in prestressed reinforcement at nominal resistance (f_{ps}) is given by the Code equation

$$f_{ps} = f_{pu} \left(1 - 0.5 \rho_p \frac{f_{pu}}{f'_c} \right) \quad \text{where,}$$

f_{pu} = Specified tensile strength of prestressed reinforcement

ρ_p = A_{ps} / bd , reinforcement ratio for prestressed reinforcement

Thus the only unknown in solving for the flexural resistance of prestressed elements in fig. 25 can be determined, as shown in the first example in this section

$$\phi M_n = \phi A_{ps} \cdot f_{ps} (d - a/2) \quad a = 1.18 \bar{w} d \quad \phi = 0.90$$

Since "a" is determined it is rather easy to find the factored moment capacity of the section. The formula differs in Turkish Code TS 3233 just substituting 0.4 instead of 0.5 coefficient.

Example: Factored flexural resistance by use of approximate equation for f_{ps}

Given : 1200 x 200 hollow core

Concrete : $f'_c = 35 \text{ N/mm}^2$

Prestressed reinforcement : 4 x 13 mm 1860 N/mm² strands

$$A_{ps} = 4 (99) = 396 \text{ mm}^2$$

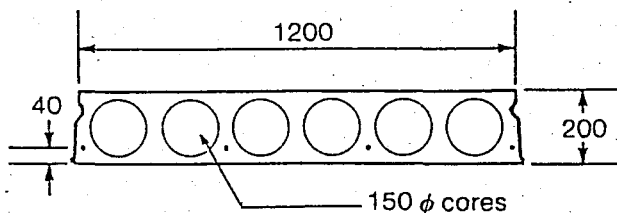

Section properties

$$: A = 134\,000 \text{ mm}^2$$

$$S_b = 6508 \times 10^3 \text{ mm}^3$$

Problem

: Find factored flexural resistance ϕM_n

Solution :

$$\rho_p = \frac{A_{ps}}{bd} = \frac{396}{1200 \cdot 160} = 0.00206$$

$$f_{ps} = f_{pu} (1 - 0.5 \rho_p \cdot f_{pu} / f'_c) = 1860 (1 - 0.5(0.00206) \frac{1860}{35}) = 1758 \text{ N/mm}^2$$

Check that depth of compression block is less than top flange thickness of $(200 - 150) / 2 = 25 \text{ mm}$

$$\bar{w} = w_p = \frac{A_{ps} \cdot f_{ps}}{b d f'_c} = \frac{396 \cdot 1758}{1200 \cdot 160 \cdot 35} = 0.103$$

$$1.18 \bar{w} d = (1.18) (0.103) (160) = 19 \text{ mm} < 25$$

$$\phi M_n = \phi f'_c b d^2 \bar{w} (1 - 0.59 \bar{w})$$

$$= (0.9) (35) (1200) (160)^2 (0.103) [1 - (0.59) (0.103)] / 10^6 = 93.6 \text{ kNm}$$

Alternatively

$$a = \frac{A_{ps} f_{ps}}{0.85 f'_c b} = \frac{396 \cdot 1758}{0.85 \cdot 35 \cdot 1200} = 19 \text{ mm}$$

$$\phi M_n = \phi A_{ps} f_{ps} (d - a/2)$$

$$= (0.9) 396 \cdot 1758 \cdot (160 - \frac{19}{2}) / 10^6 = 94.7 \text{ kNm}$$

Check the ductility requirement that $\phi M_n \geq 1.2 M_{cr}$

Assuming an effective prestress $f_{se} = 1030 \text{ N/mm}^2$

$$P = f_{se} \cdot A_{ps} = (1030) (396) / 10^3 = 408 \text{ kN}$$

$$\begin{aligned}
 1.2 M_{cr} &= 1.2 \left(\frac{P}{A} + \frac{P e}{S_b} + 0.6 \sqrt{f'_c} \right) S_b \\
 &= 1.2 \left(\frac{408000}{134000} + \frac{408000 \cdot 60}{6508000} + 0.6 \sqrt{35} \right) \frac{6508000}{10^6} = 80.9 \text{ kNm} < 93.6 \text{ O.K}
 \end{aligned}$$

6.2.1.2. Analysis Using Strain Compatibility

Fig. 26 taken from ref. 8 represents a plot of the stress induced in bonded prestressing strand as a ratio of its tensile strength based on stress-strain compatibility. It can be seen from fig. 26 that for high values of $C_w \cdot w_{pu}$, 5 to 15 percent savings in steel can be achieved using this more precise method of analysis compared to using the approximate equation for f_{ps} just described above. After obtaining f_{ps} from this figure, the flexural resistance is determined using the equations given in flow chart, fig. 27. An example is given related to flow chart and strain compatibility analysis at the end of this sub-section. Hereby,

C_w = Coefficient used for stress-strain relationship of bonded strand

$$w_{pu} = \frac{A_{ps}}{b \cdot d} \frac{f_{pu}}{f'_c}$$

Example: Use of Fig. 26 Values of f_{ps} by stress-strain relationship-bonded strand

Given = 1200 x 200 hollow core slab

- Concrete : $f'_c = 35 \text{ N/mm}^2$
 Prestressed reinforcement : 12x13 mm 1860 N/mm² strand
 $A_{ps} = (12) (99) = 1188 \text{ mm}^2$
 Problem : Find the factored flexural resistance ϕM_n

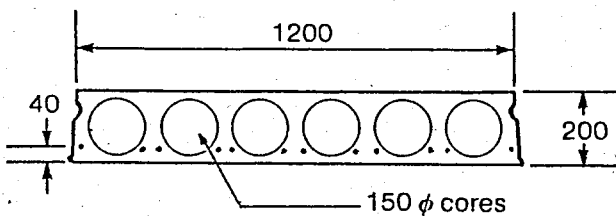

$$C_{w,\omega_{pu}} = C_w \frac{A_{ps}}{bd} \frac{f_{pu}}{f'_c}$$

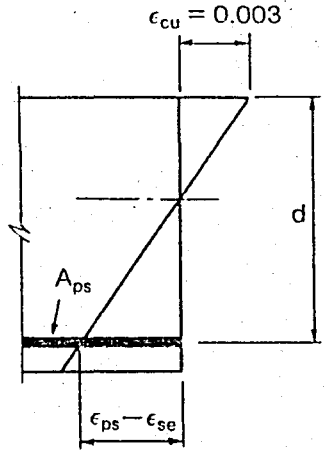

Values of C_w	
f'_c (MPa)	C_w
20	1.00
25	1.00
30	1.02
35	1.06
40	1.12
45	1.17
50	1.24
55	1.31

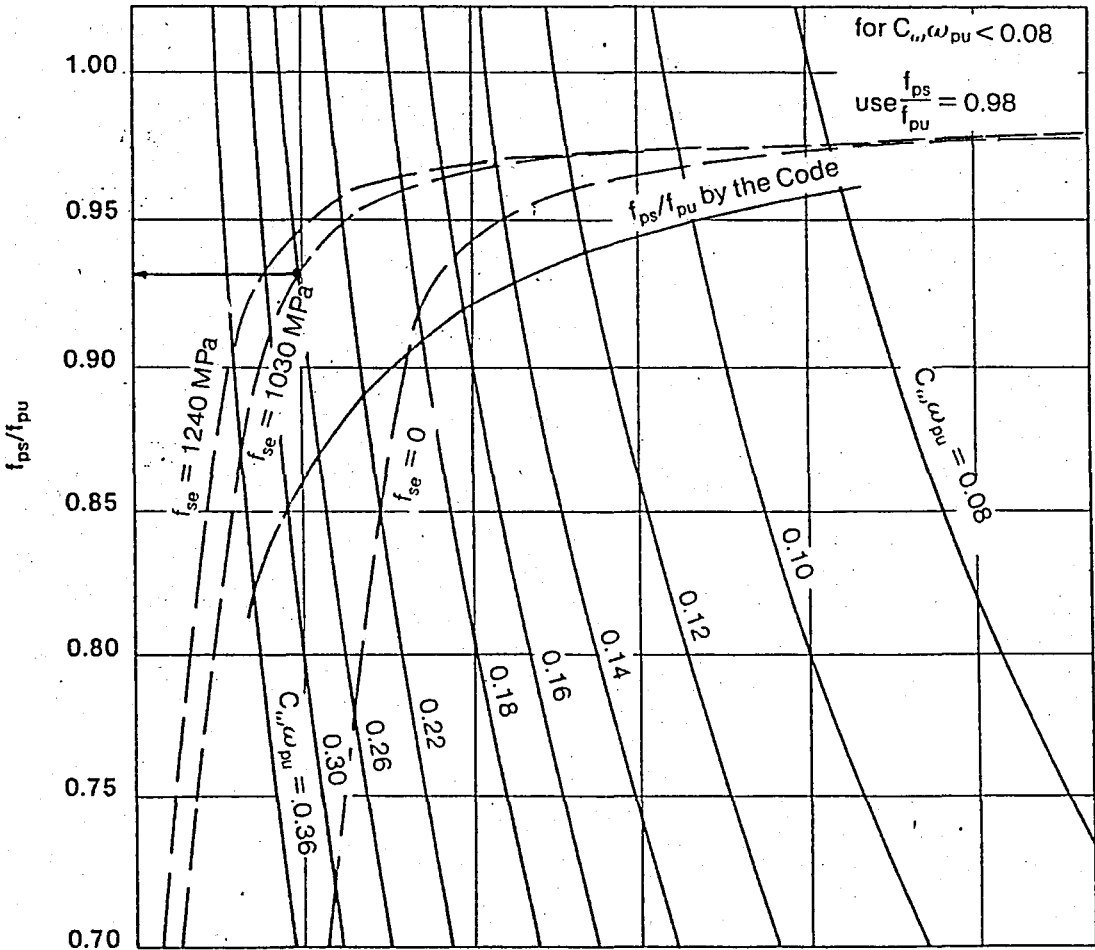

Fig. 26 Values of f_{ps} by stress-strain relationship-bonded strand

Solution

: Determine $C_w \cdot w_{pu}$ for the sectionFor $f'_c = 35 \text{ N/mm}^2$ from fig. 26 $C_w = 1.06$

$$C_w w_{pu} = \frac{C_w A_{ps} f_{pu}}{b d f'_c} = \frac{(1.06)(1188)(1860)}{(1200)(160)(35)} = 0.349$$

Usually reinforcements are prestressed to 70 percent of their tensile strength, and the loss of prestress is assumed to be 21 percent of initial prestressing. Therefore,

$$f_{se} = (0.70) (1860) (0.79) = 1030 \text{ N/mm}^2$$

Entering Fig. 26 with $C_w w_{pu} = 0.349$ and $f_{se} = 1030$ gives a value of :

$$f_{ps} / f_{pu} = 0.88 \quad f_{ps} = (0.88) (1860) = 1637 \text{ N/mm}^2$$

Referring to flow chart of Fig. 27

$$\bar{w} = \frac{A_{ps} \cdot f_{ps}}{b d f'_c} = \frac{1188 \cdot 1637}{1200 \cdot 160 \cdot 35} = 0.289 < 0.3$$

Therefore, section is not over reinforced

$$\begin{aligned} \phi M_n &= \phi f'_c b d^2 \bar{w} (1 - 0.59 \bar{w}) \\ &= (0.9) (35) (1200) (160)^2 (0.289) [1 - (0.59) (0.289)] / 10^6 = 232 \text{ kNm} \end{aligned}$$

This capacity can be compared with the value obtained using the approximate code equation for f_{ps} :

$$f_{ps} = f_{pu} (1 - 0.5 \rho_p \frac{f_{pu}}{f'_c})$$

$$f_{ps} = 1860 (1 - \frac{0.5 \cdot 1188 \cdot 1860}{1200 \cdot 160 \cdot 35}) = 1554 \text{ N/mm}^2$$

$$\bar{w} = \frac{A_{ps} \cdot f_{ps}}{b d f'_c} = \frac{1188 \cdot 1554}{1200 \cdot 160 \cdot 35} = 0.275 < 0.3$$

$$\phi M_n = (0.9) (35) (1200) (160)^2 (0.275) [1 - (0.59) (0.275)] / 10^6 = 223 \text{ kNm}$$

Note that this value of ϕM_n is 4 percent lower than the value obtained by the more precise strain compatibility analysis method.

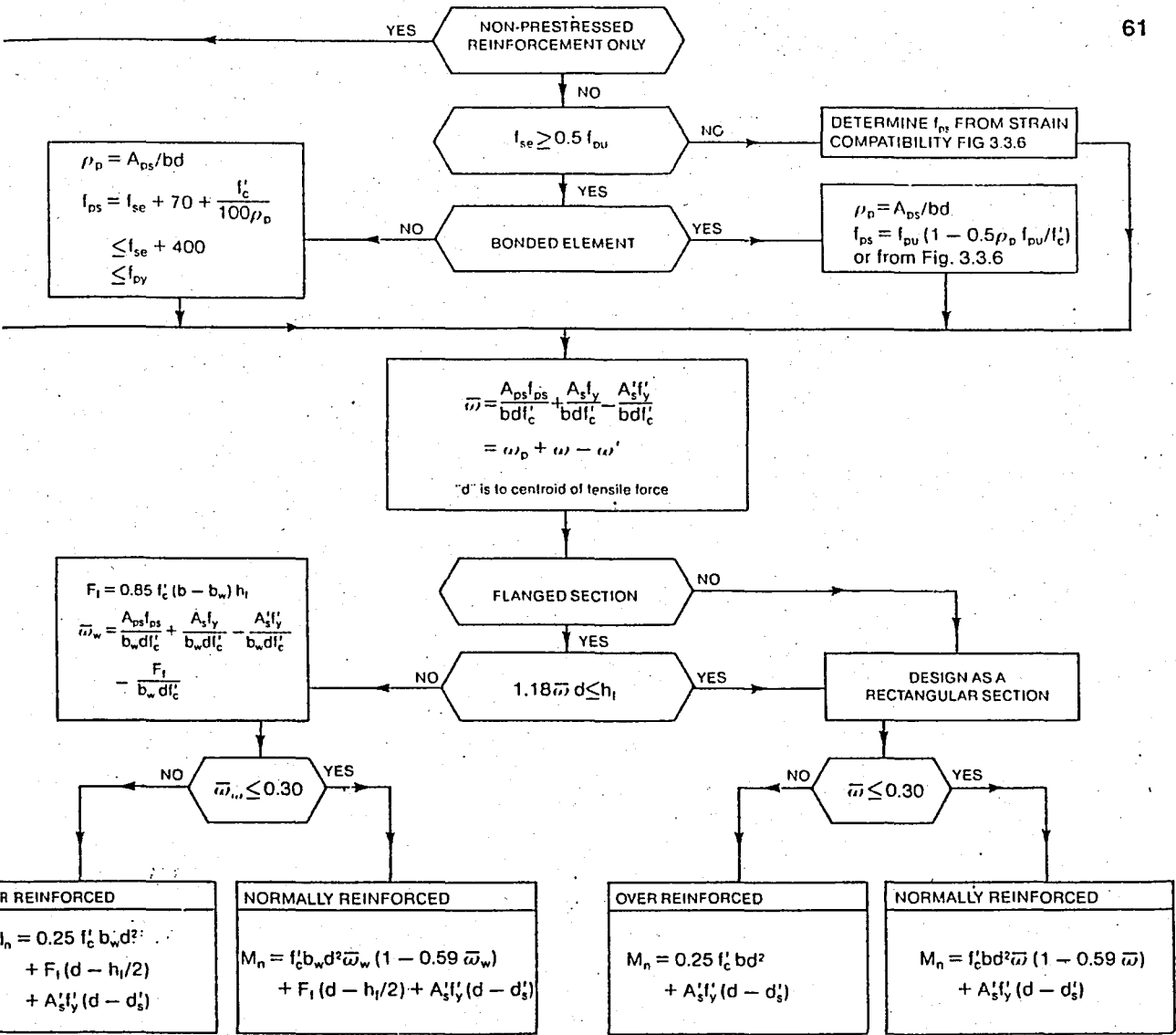

Fig. 27 Flow chart for flexural resistance calculations

6.2.3. Flexural Resistance at Service Limit State

Unlike concrete, reinforced with non-prestressed reinforcement, it is necessary that service load stresses in prestressed elements be checked at critical points, in addition to design for the ultimate limit state. Limitations on the service load stresses according to the TS 3233 are summarized as follows :

Allowable stresses in concrete :

- 1- At release (transfer) of prestress, before time dependent losses
 - a) Compression : $0.6 f_{ci}$

- b) Tension (except ends) : $0.25 f_{ci}$
- c) Tension at ends of simply supported elements : $0.5 f_{ci}$

2- Under service loads :

- a) Compression : $0.45 f_c'$
- b) Tension in precompressed tensile zone : $0.5 \sqrt{f_c'}$

Allowable Stresses in Prestressed Reinforcement :

- 1- Tension during tendon jacking : $0.80 f_{pu}$
- 2- Tension immediately after prestress transfer :
 - a) Stress relieved strand or wire : $0.70 f_{pu}$
 - b) Low relaxation strand or wire : $0.75 f_{pu}$

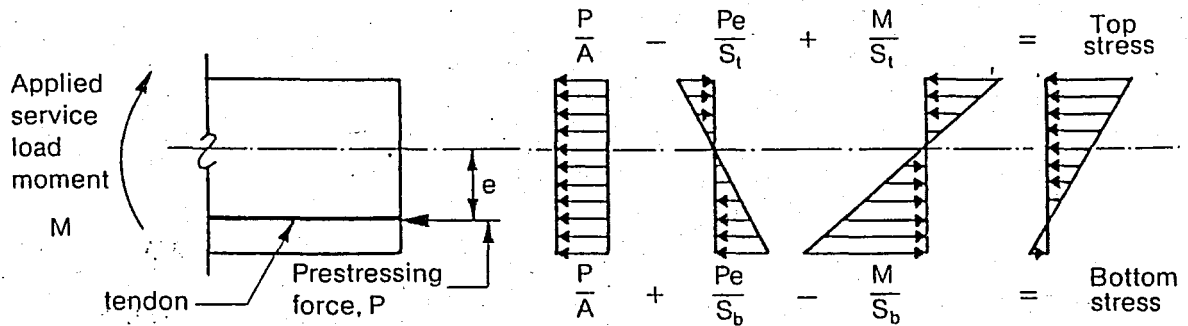

Fig. 28 Calculation of service load stresses

Critical Sections

For stresses immediately after transfer, the most critical section is usually near the end of the element. The actual critical end stress is at the point where the prestressing force has been completely transferred to the concrete, usually assumed to be 50 strand diameters from the end. For convenience, using hand calculation, it is normal practice to calculate the stress at the end (assuming full transfer), and check the transfer point only if necessary to meet code requirements. If release stresses are higher than allowed by code, it may be necessary to either increase the specified release strength, or provide supplemental tensile reinforcement. In short span, heavily loaded elements, such as beams, it is usually more practical to reinforce for the release tension. Under uniform service loads, the critical section is at midspan for elements with straight tendons and near 0.4 l from the end for elements with tendons depressed at midpoint. The exact

critical point can be determined by a detailed analysis, but designing for critical stresses at the midspan and 0.4 l points will usually determine the capacity within 1 or 2 percent.

Composite Elements

It is usually more economical to place cast-in-place composite topping without shoring the elements, especially for deck elements. This means that the mass of the topping must be carried by the precast element alone. Additional superimposed dead and live loads are carried by the composite section.

Example : Calculation of flexural resistance at service limit state

Given : 1200 x 300 hollow core slab, span = 14 m

Problem : Find critical service load stresses

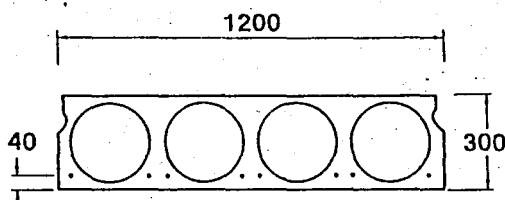

Superimposed dead load = $0.5 \text{ kN/m}^2 = 0.60 \text{ kN/m}$

Superimposed live load = $1.75 \text{ kN/m}^2 = 2.10 \text{ kN/m}$

Concrete :

$$f'_c = 35 \text{ N/mm}^2 \quad f'_{ci} = 25 \text{ N/mm}^2$$

Prestressed reinforcement :

$$8\text{-}13 \text{ mm} \quad 1860 \text{ N/mm}^2 \text{ strands, } A_{ps} = 8 (99) = 792 \text{ mm}^2$$

Section properties :

$$A = 179\,000 \text{ mm}^2$$

$$I = 2049 \times 10^6 \text{ mm}^4$$

$$y_b = 150 \text{ mm}$$

$$y_t = 150 \text{ mm}$$

$$S_b = 13657 \times 10^3 \text{ mm}^3$$

$$S_t = 13657 \times 10^3 \text{ mm}^3$$

$$m = 357 \text{ kg/m}^2 = 428 \text{ kg/m}$$

Problem : Find critical service load stresses.

Solution :

Prestress loss :

$$\begin{aligned}
 P_i &= (792) (0.70) (1860) / 10^3 = 1030 \text{ kN} \\
 P_o &= (0.90) (1030) = 927 \text{ kN (Assume 10 \% initial loss)} \\
 P &= (0.76) (1030) = 783 \text{ kN (Assume 24 \% total loss)} \\
 e &= 150 - 40 = 110 \text{ mm}
 \end{aligned}$$

Service load moments :

- at midspan :

$$\begin{aligned}
 M_d &= (4.28) (14)^2 / 8 = 105 \text{ kNm} \\
 M_{sd} &= (0.60) (14)^2 / 8 = 15 \text{ kNm} \\
 M_l &= (2.10) (14)^2 / 8 = 51 \text{ kNm}
 \end{aligned}$$

According to the allowable stress specified by the Turkish Code TS 3233, 1200 x 300 hollow core element is suitable under the loads given.

Load	Support at Release $P = P_o$		Midspan at Release $P = P_o$		Midspan at Service Load $P = P_o$	
	f_b	f_t	f_b	f_t	f_b	f_t
P/A	5.2	5.2	5.2	5.20	4.4	4.4
P_e/S	7.5	-7.5	7.5	-7.5	6.3	-6.3
M_d/S	-	-	-7.7	7.7	-7.7	7.7
M_{sd}/S	-	-	-	-	-1.1	1.1
M_l/S	-	-	-	-	-3.7	3.7
Stresses	+12.7	-2.3	+5.0	+5.4	-1.8	10.6
Allowable Stresses (TSE)	$0.6 f'_{ci}$	$-0.5 f'_{ci}$	$0.6 f'_{ci}$	$0.6 f'_{ci}$	$-0.5 f'_c$	$0.45 f_t$
	15	-2.5	15	15	-3.0	+15.8
	O.K	O.K	O.K	O.K	O.K	O.K

6.2.4. Prestress Losses

Loss of prestress is the reduction of tensile stress in prestressing tendons due to shortening of the concrete around the tendons, relaxation of stress within the tendons, and external factors which reduce the total initial force before it is applied to the concrete. The prestress losses are as follows :

Anchorage seating loss and friction :

These two sources of loss are mechanical. They represent the difference between the tension applied to the tendon by the jacking unit and the initial tension available for application to the concrete by the tendon.

Elastic shortening of concrete :

The concrete around the tendons shortens as the prestressing force is applied to it. Those tendons which are already bonded to the concrete shorten with it.

Shrinkage of concrete :

Loss of stress in the tendon due to shrinkage of the concrete surrounding it is proportional to that part of the shrinkage that takes place after the transfer of prestress force to the concrete.

Creep of concrete and relaxation of tendons :

Losses due to creep of concrete and relaxation of tendons complicate stress loss calculations. The rate of loss due to each of these factors changes when the stress level changes and the stress level is changing constantly throughout the life of the structure. Therefore, the rates of loss due to creep and relaxation are constantly changing.

Prestress Loss by PCI Committee Method

Recommendations for Estimating Prestress Losses", prepared by the

PCI Committee on Prestress Losses, presents a "General Method" and a "Simplified Method" to determine total prestress losses.

The General Method considers a number of time intervals during the life of the structure. It establishes the stress levels existing in the tendons and the concrete at the beginning of each interval, computes the loss due to each factor during the interval, and determines the stress levels in tendons and concrete at the end of the interval.

The simplified method is based on the General Method but eliminates most of the mathematics. Using the Simplified Method, stress loss is determined by computing the value of f_{cr} (concrete stress at centroid of prestress force immediately after transfer) and f_{cds} (concrete compressive stress at centroid of prestress force due to all permanent dead loads not used in computing f_{cr}) and substituting them in the appropriate empirical equations. These equations are used to compute total loss TL in N/mm^2 . Total loss is the sum of losses due to shrinkage, elastic shortening and creep of concrete plus loss due to relaxation of tendons.

For normal density concrete :

$$TL = 228 + 13.8 f_{cr} - 4.5 f_{cds} \text{ (Using stress-relieved strand)}$$

$$TL = 137 + 16.3 f_{cr} - 5.4 f_{cds} \text{ (Using low-relaxation strand)}$$

For semi-low density concrete :

$$TL = 215 + 16.8 f_{cr} - 3.8 f_{cds} \text{ (Using stress-relieved strand)}$$

$$TL = 121 + 20.4 f_{cr} - 4.8 f_{cds} \text{ (Using low-relaxation strand)}$$

For typical elements, the only variable that is not included in the equations but could make an appreciable difference in the net result is volume/surface ratio. A correction factor is applied for that :

V/S ratio (mm)	25	50	75	100
Adjustment (percent)	+3.2	0	-3.8	-7.6

Table 5- Correction Factors For Prestress Losses

Example : For $V/S = 75$ reduce losses by 3.8 percent

The equations above are based on the initial tension, after reduction for anchor slip, normally used in pretensioned elements i.e., $0.7 f_{pu}$ for low-relaxation strand. Use of a higher or lower initial tension will result in an appreciable change in net losses especially in the case of stress-relieved tendons. Use of the equations requires calculation of the stresses f_{cr} and f_{cds}

$$f_{cr} = P_0/A + P_0 \cdot e^2 / I - M_d \cdot e / I$$

$$f_{cds} = M_{sd} \cdot e / I \quad \text{where;}$$

A = Area of the precast section

e = Eccentricity of the strand at the critical section

f_{cds} = Concrete stress at centroid of tendon at the critical section caused by sustained loads not included in the calculation of f_{cr}

f_{cr} = Concrete compressive stress at centroid of tendon at critical section immediately after transfer

I = Moment of inertia of the section

M_d = Moment due to mass of the element

M_{sd} = Moment due to all sustained loads except the element mass

P_0 = Prestress force at transfer, after initial loss. It is within reasonable accuracy to assume 10 % initial loss for stress relieved strand and 7.5 % initial loss for low-relaxation strand.

Example : Loss of prestress-depressed stress relieved strand.

Given : 1200 x 300 hollow core slab, with 50 mm topping, span : 12 m, no superimposed dead load except topping

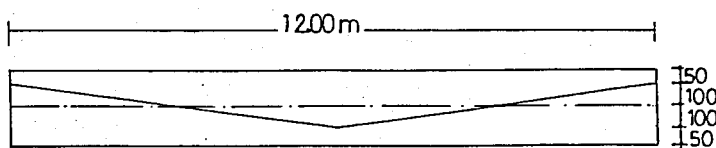
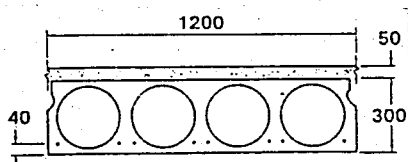

Concrete : $f'_c = 35 \text{ N/mm}^2$

$f'_{ci} = 25 \text{ N/mm}^2$ Normal density concrete

Prestressed reinforcement :

$$12 \times 13 \text{ mm } 1860 \text{ N/mm}^2 \text{ strand} \quad A_{ps} = (12) (99) = 1188 \text{ mm}^2$$

Section properties (untopped)

$$A = 179\,000 \text{ mm}^2$$

$$I = 2049 \times 10^6 \text{ mm}^4$$

$$S_b = 13657 \times 10^3 \text{ mm}^3$$

$$V/S = 60 \text{ mm}$$

$$w = 350 \text{ kg/m}^2 = 420 \text{ kg/m}$$

$$w \text{ of topping} = 120 \text{ kg/m}^2 = 144 \text{ kg/m}$$

Depressed at mid-span :

$$e_e = 100 \text{ mm (at end)}$$

$$e_c = 100 \text{ mm (at centre)}$$

Problem :

Determine total loss of prestress by PCI Committee simplified method

Solution :

For depressed strand, critical section is at 0.4 l. Determine moments, eccentricity, and prestress force :

$$M, \text{ at } 0.4 \text{ l} = W \cdot x/2 (1-x) = W \cdot (0.4l) / 2 (1-0.4l) = 0.12 \text{ } w l^2$$

$$M_d = 0.12 \cdot (0.420) \cdot (12)^2 = 7.26 \text{ tm}$$

$$M_{sd} = 0.12 \cdot 0.144 \cdot (12)^2 = 2.49 \text{ tm}$$

$$e \text{ at } 0.4 \text{ l} = 0.8 \cdot 20 - 10 = 6 \text{ cm}$$

$$P_i = 0.7 \cdot A_{ps} \cdot f_{pu} = (0.7) \cdot 1188 \cdot 1860 / 10^4 = 155 \text{ t}$$

$$P_o = 0.9 \cdot P_i = (0.9) (155) = 140 \text{ t}$$

Determine f_{cr} and f_{cds}

$$f_{cr} = \frac{P_o}{A} + \frac{P_o e^2}{I} - \frac{M_d e}{I}$$

$$f_{cr} = \frac{1400 \cdot 10^3}{179000} + \frac{1400(60)^2(10)^3}{2049 \cdot 10^6} - \frac{(72.6) 60 \cdot 10^6}{2049 \cdot 10^6}$$

$$f_{cr} = 7.82 + 2.46 - 2.13 = 8.15 \text{ N/mm}^2$$

$$f_{c ds} = \frac{M_{sd} \cdot e}{I} = \frac{24.9 \cdot 60 \cdot 10^6}{2049 \cdot 10^6} = 0.73 \text{ N/mm}^2$$

For normal density concrete and stress-relieved strand :

$$TL = 228 + 13.8 f_{cr} - 4.5 f_{c ds}$$

$$TL = 228 + (13.8) (8.15) - (4.5) (0.73) = 337 \text{ N/mm}^2$$

Adjust for V/S = 60 mm ratio (interpolate between 50 and 75)

$$\text{Adjustment factor} = -3.8 + (75-60) \cdot 3.8 / (75-50) = -1.52 \%$$

$$(-1.52/100) \cdot 337 = -5.12 \text{ N/mm}^2$$

$$\text{Final loss is } 337 - 5.12 = 331.9 \text{ N/mm}^2$$

Final prestress force :

$$P = 1550 - 331.9 \cdot 1188 / 10^3 = 1156 \text{ kN} = 115.6 \text{ t}$$

6.2.5 Camber and Deflection

Camber is the upward deflection of a prestressed member and results from the prestressing force being eccentric from the center of gravity of the cross-section. Since both prestressing force and eccentricity are established by the required design load and span length, camber is a result of the design rather than a design parameter. Therefore, camber requirements should not be specified.

Deflections are also affected by the amount of prestressing only because prestressing establishes the load at which a member will crack. If tensile stresses are kept below cracking, deflections will be independent of the prestress level. Cambers and deflections will change with time due to concrete creep, prestress loss and other factors. The sustained compression due to the prestressing will cause camber growth. Balancing this is the effect of creep on deflections due to self weight and other sustained loads. It is this time dependent movement which, in addition to instantaneous deflections, must be considered in the development of framing schemes and detailing.

Instantaneous cambers and deflections are predictable as long as the material properties are known. The time dependent cambers and deflections are not predictable with any degree of accuracy and any calculation of long term movements must be considered to be only estimates.

6.2.5.1. Camber

Hollow core slabs are produced with straight strand patterns rather than using draped or depressed strands. Using (+) to indicate upward movement and (-) to indicate downward movement, net camber can be calculated as :

$$\text{Camber} = P.e.l^2 / 8EI - 5w \cdot l^4 / 384 EI$$

To determine initial camber, the appropriate values for prestress force and modulus of elasticity of the concrete must be used. When ultimate moment rather than tensile stress govern a design, the initial strand stress may be reduced to modify the anticipated camber. Additionally, slab camber is sensitive to support point locations during storage. Camber will increase as these support points move in from the slab ends.

Example : Initial camber calculation

Given : 20 cm 1200 x 200 hollow core slab, concrete BS 35

Prestressing steel :

6x13 mm dia. 18600 kg/cm² low relaxation strands. $A_{ps} = 0.99 \text{ cm}^2$

$A_{ps} \cdot f_{pu} = 0.99 \cdot 18600 = 18414 \text{ kg/strand}$

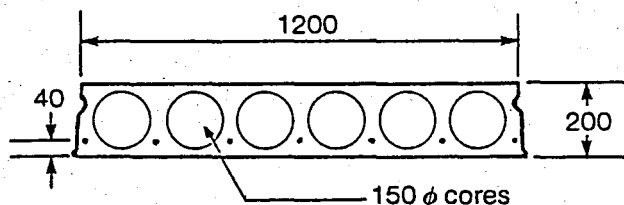

Initial stress : 70 % f_{pu} , span : 10 m, $E = 332\,000 \text{ kg/cm}^2$

Section properties :

$$d_p = 200 - 40 = 160 \text{ mm}$$

$$I = 65100 \text{ cm}^4$$

$$e = y_b - 4 = 10 - 4 = 6 \text{ cm}$$

$$w = 260 \text{ kg/m}^2 = 312 \text{ kg/m}$$

Solution :

$$P_o = 0.95 \cdot 0.70 \cdot 6 \cdot 18414 = 73472 \text{ kg}$$

$$\text{Camber} : \frac{73472 \cdot 6 \cdot (900)^2}{8 \cdot 332000 \cdot 65100} - \frac{5 \cdot (3.12) \cdot (900)^4}{384 \cdot 332000 \cdot 65100} = 2.07 - 1.23 = 0.84 \text{ cm}$$

Estimating long term effects is complicated because, as time passes, prestressing force decreases due to losses and the modulus of elasticity of the concrete increases with concrete strength again. Traditionally, a creep factor of 2.0 has been applied to instantaneous deflections to estimate the additional deflection due to creep. Table 6 (Ref. 5) presents suggested multipliers to determine both long term final deflections and position at erection. It should be noted that in using these multipliers, a total deflection is calculated rather than the additional increment due to long term effects.

Condition	Without Composite Topping	With Composite Topping
At Erection:		
1. Deflection (downward) component - apply to the elastic deflection due to the member weight at release of prestress	1.85	1.85
2. Camber (upward) component - apply to the elastic camber due to the prestress at the time of release of prestress	1.80	1.80
Final:		
3. Deflection (downward) component - apply to the elastic deflection due to the member weight at release of prestress	2.70	2.40
4. Camber (upward) component - apply to the elastic camber due to prestress at the time of release of prestress	2.45	2.20
5. Deflection (downward) - apply to elastic deflection due to superimposed dead load only	3.00	3.00
6. Deflection (downward) - apply to elastic deflection caused by the composite topping	—	2.30

Table 6- Long Term Multipliers

Example : For the slab of example before, determine the net camber at erection and the final camber

Solution :

At erection ; Initial camber = $2.07 - 1.23 = 0.84$ cm

Erection camber = $2.07 (1.80) - 1.23 (1.85) = 1.45$ cm

Final : Final camber = $2.07 (2.45) - 1.23 (2.70) = 1.75$ cm

6.2.5.2 Deflections

As with camber, concrete creep will also affect deflections due to sustained superimposed loads. These long term effects must be considered for comparison with permissible computed deflections specified in Table 7 taken from ACI- 318.83 or TS 3233 referring to TS 500 code. Engineering judgement should be used in comparing calculated deflections to the code limits. Many code specified live loads exceed the actual loads in a structure. While it may be implied that the full live load be used for comparison to Table 7, situations may arise where it is more reasonable to use actual anticipated live loads for deflection comparisons.

Type of Element	Deflection to be Considered	Deflection Limitation
Flat roofs not supporting or attached to non-structural elements likely to be damaged by large deflections	Immediate deflection due to the live load	$\frac{l}{180}$
Floors not supporting or attached to non-structural elements likely to be damaged by large deflections	Immediate deflection due to the live load	$\frac{l}{360}$
Roof or floor construction supporting or attached to non-structural elements likely to be damaged by large deflections	That part of the total deflection which occurs after attachment of the non-structural elements, the sum of the long-time deflection due to all sustained loads and the immediate deflection due to any additional live load ⁽²⁾	$\frac{l}{480}$
Roof or floor construction supporting or attached to non-structural elements not likely to be damaged by large deflections		$\frac{l}{240}$

Table 7- Maximum allowable computed deflections

A further complication for superimposed loads is that flexural cracking will reduce the effective moment of inertia of the section. Calculations using bilinear moment-deflection relationships are required when tension exceeds $0.5 f_{ci}$ and are covered extensively in ACI 318-83 and PCI Design Handbook. By definition, cracking occurs at a tensile stress of $0.6 f_{ci}$. While the ACI Code requires such bilinear calculations when $0.5 f_{ci}$ tension is exceeded, in effect bilinear behavior is meaningless up to a tension of $0.6 f_{ci}$.

Since hollow core slabs are normally designed to be uncracked under service loads, the effects of cracking will not be considered in deflection calculation. Table 6 in section 6.2.5.1. includes multipliers for determining the long term effects for superimposed loads. Again, use of the multipliers gives an estimate of total deflection rather than an increment for the additional long term deflection.

Example : For the slab of Examples in section 6.5.1, determine the total deflection due to a superimposed load of 100 kg/m^2 dead and 250 kg/m^2 live on a clear span of 9 m including long term effects.
Use $E_c = 332\,000 \text{ kg/cm}^2$

Solution :

From example before, Final camber = 1.75 cm

$$100 \text{ kg/m}^2 = 100 \cdot (1.20) = 120 \text{ kg/m} \quad (1.20 : \text{slab width})$$

Superimposed dead load instantaneous deflection :

$$\frac{5 w l^4}{384 E_c I} = \frac{5 \cdot 120 (900)^4}{384 \cdot 332000 \cdot 65100} = 0.47 \text{ cm}$$

$$\text{Final deflection} = 0.47 \cdot (3.00) = 1.41 \text{ cm}$$

Instantaneous live load deflection : $250 \text{ kg/m}^2 = 300 \text{ kg/m}$

$$5 \times 300 \times (900)^4 / (384 \times 332000 \times 65100) = 1.19 \text{ cm}$$

Final position :

Final camber	=	1.75
Sustained dead load	=	-1.41
Net camber	=	0.34
Live load increment	=	-1.19
	=	-0.85 cm (↓)

Note that, if any topping is to be poured on the slab, deflection increment due to topping should be calculated and added also.

6.2.6. Shear Design

For elements with an effective prestress force at least equal to 40 percent of the tensile strength of the flexural reinforcement, the nominal shear resistance V_c is :

$$V_c = (0.05 \sqrt{f'_c} + S \frac{V_u d}{M_u}) b_w d \quad \text{but,}$$

$$0.17 f'_c b_w d \leq V_c \leq 0.4 \sqrt{f'_c} b_w d \quad \text{and} \quad \frac{V_u d}{M_u} \leq 1.0$$

Alternatively, V_c may be taken as the lesser of V_{ci} or V_{cw} where the inclined flexure-shear cracking resistance V_{ci} is :

$$V_{ci} = 0.05 \sqrt{f'_c} b_w d + V_d + \frac{V_u M_{cr}}{M_{max}} \quad \text{where,}$$

$$V_{ci} \geq 0.14 \sqrt{f'_c} b_w d$$

$$M_{cr} = \frac{I}{y_t} (0.5 \sqrt{f'_c} + f_{pe} - f_d)$$

The web-shear cracking resistance V_{cw} equals :

$$V_{cw} = (0.3 \sqrt{f'_c} + 0.3 f_{pc}) b_w d + V_p$$

Alternatively, V_{cw} may be computed as the shear force corresponding to the dead load plus live load resulting in a principal tensile stress of $0.33 f'_c$. ACI Code 318-83 places certain upper and lower limits on the use of these equations, which are shown in Fig. 29

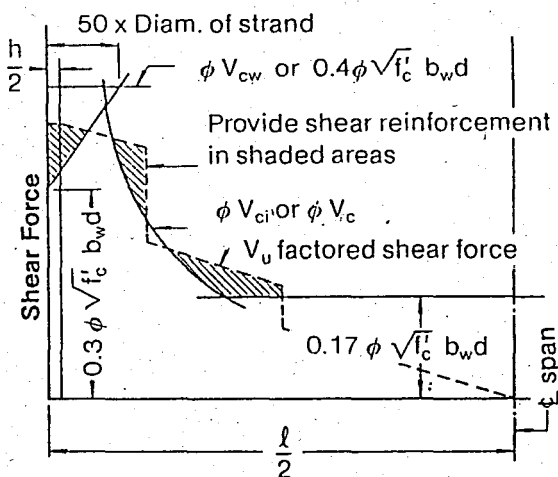

Fig. 29 Shear Diagram

The distance d is the effective depth from the extreme compression fibre to the centroid of the longitudinal tension reinforcement, but need not be taken less than $0.80 h$, except in the expression $V_u d / M_u$ where d is limited to the actual effective depth. In unusual cases, such as elements which carry heavy concentrated loads, or short spans with light superimposed loads, it may be necessary to construct the shear resistance diagram (ϕV_c) and superimpose the factored shear force diagram (V_u) as illustrated in Fig. 29

The steps for constructing the shear resistance diagram are as follows :

- 1- Draw a horizontal line at a value of $0.17 \phi f_c b_w d$.
- 2- Construct the curved portion of the diagram. For this, either ϕV_{ci} or, more conservatively, ϕV_c may be used. Usually it is adequate to find 3 points on the curve.
- 3- Draw the upper limit line, ϕV_{cw} if V_{ci} has been used in step 2, or $0.4 \phi \sqrt{f'_c} b_w d$ if V_c has been used.
- 4- The diagonal line at the upper left of Fig. 29 delineates the upper limit of the shear resistance diagram in the prestress transfer zone. This line starts at a value of $0.3 \phi \sqrt{f'_c} b_w d$ at the end of the element, and intersects the ϕV_{cw} line at 50 strand diameters from the end of the element.

Example : Construction of Shear Diagram

Given : 1200 x 300 hollow core slab and loadings shown

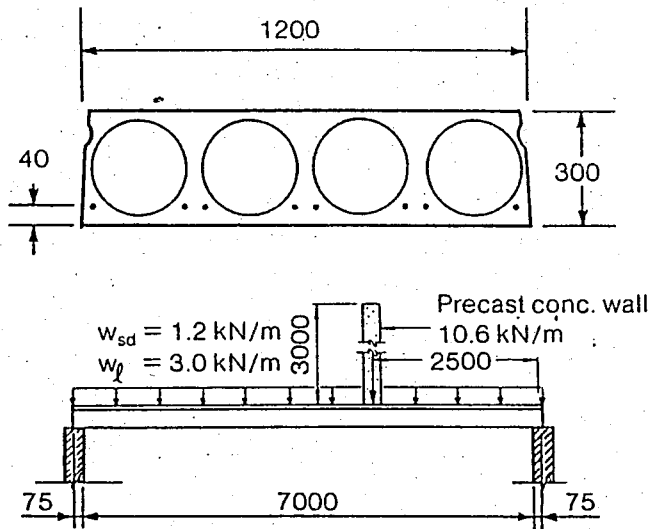

Section properties :

$$\begin{aligned}
 A &= 179\,000 \text{ mm}^2 \\
 I &= 2049 \times 10^6 \text{ mm}^4 \\
 y_b &= 150 \text{ mm} \\
 b_w &= 240 \text{ mm} \\
 w &= 3.5 \text{ kN/m}^2 = 0.42 \text{ t/m}
 \end{aligned}$$

Concrete :

$$f'_c = 35 \text{ N/mm}^2, \text{ normal density}$$

Prestressed reinforcement :

$$8 \times 13 \text{ mm } 1860 \text{ N/mm}^2 \text{ strands}$$

$$P = \frac{8 (99) (0.79) (0.70) (1860)}{10^3} = 814 \text{ kN} \text{ assuming } 21 \% \text{ losses}$$

Solution :

1- Determine factored loads

$$\text{Uniform dead} = 1.40 (1.20 + 4.20) = 7.6 \text{ kN/m}$$

$$\text{Uniform live} = 1.60 (3.0) = 5.1 \text{ kN/m}$$

$$\text{Concentrated dead} = 1.4 (1.20) (10.6) = 17.8 \text{ kN}$$

2- Construct the applied factored shear force diagram as shown

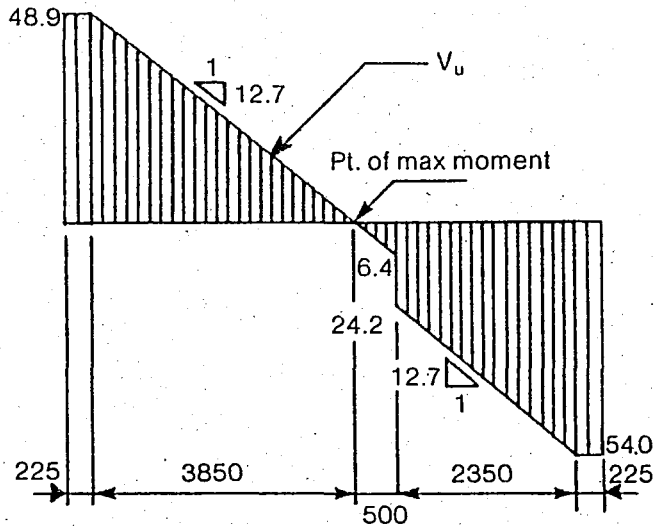

3- Construct the factored shear resistance diagram as described in previous section:

a) Construct line at $0.17 \phi \sqrt{f'_c} b_w d$
 $= (0.17) (0.85) \sqrt{35} (240) (260) / 1000 = 53.3 \text{ kN}$

b) Construct ϕV_c line :

$$\phi V_c = \phi (0.05 \sqrt{f'_c} + 5 V_u d / M_u) b_w d$$

$$\phi V_c = (0.85) ((0.05 \sqrt{35} + (5) (260) V_u / M_u) (240) (260) / 10^3$$

$$\phi V_c = 15.7 + 68900 V_u / M_u$$

$$V_{u\text{left}} = 50800 - 12.7 x$$

$$M_{u\text{left}} = 50800 x - 12.7 x^2 / 2$$

$$V_{u\text{right}} = 55900 - 12.7 x$$

$$M_{u\text{right}} = 55900 x - 12.7 x^2 / 2$$

Point	x (mm)	V_u (N)	M_u (N•mm)	$68900 \frac{V_u}{M_u}$ (kN)	ϕV_c (kN)
1	300	47 000	14 700 000	220.7	236.4
2	600	43 200	28 200 000	105.5	121.2
3	1 200	35 600	51 800 000	47.3	63.0
4	300	52 100	16 200 000	221.6	237.2
5	600	48 300	31 300 000	106.3	122.0
6	1 200	40 700	57 900 000	48.4	64.1

c) Construct upper limit line at :

$$0.4 \phi \sqrt{f'_c} b_w d = (0.4) (0.85) \sqrt{35} (240) (260) / 10^3 = 125.5 \text{ kN}$$

VII- SPECIAL DESIGN CONSIDERATIONS

The application of hollow core slabs as roof and floor deck members creates several situations for consideration in design which are either not completely covered by the codes or which involve consideration of production processes. In this section, load distribution mechanisms, its design considerations, effect of openings, continuity over supports and cantilever design concept will be discussed.

7.1. Load Distribution Mechanism

Hollow core slabs are designed as individual, one way, simple span slabs. When the slabs are installed and grouted together at the keyways, the individual slabs become a system that behaves similarly to a monolithic slab. A major benefit of the slabs acting together is the ability to transfer forces from one slab to another. In most hollow core slab deck applications, non-uniform loading occurs in the form of line loads, concentrated loads, or load concentrations at openings.

As load is applied to one slab in a system, the response of the slab system is to deflect and also twist if the load is not on the longitudinal centerline of the system. Several factors affect the ability of a slab system to distribute loads to adjacent slabs. As the width of an assembly of slabs gets narrower than the span length, a reduction in the number of slabs contributing to the support of a concentration of load occurs. This occurs because the freedom of the free edges of the system to deflect and twist becomes more significant. A second factor is the spacing of the slab joints. When one hollow core slab element is loaded with a point load, or with a knife edge distributed load, the adjacent slab elements will also participate in carrying this load, due to the continuity existing along the keyways. The amount of participation by the adjacent slab elements is very difficult to determine. Therefore, some approximate distances are assumed, for the influence of these irregular loads. There are basically two different methods to determine the distribution of irregular loads. These methods are illustrated in Figs. 30 and 32. In method A (Ref. 5), the shears and bend-

ing moments of a particular point load, or knife edge load, are calculated across the span of the slab element, then after being divided by the corresponding distribution widths, they are added onto the uniform load values. Note that, the distribution widths, vary from a constant value in the support region, to a final constant width, in the middle half segment of the span, as shown in Fig. 30

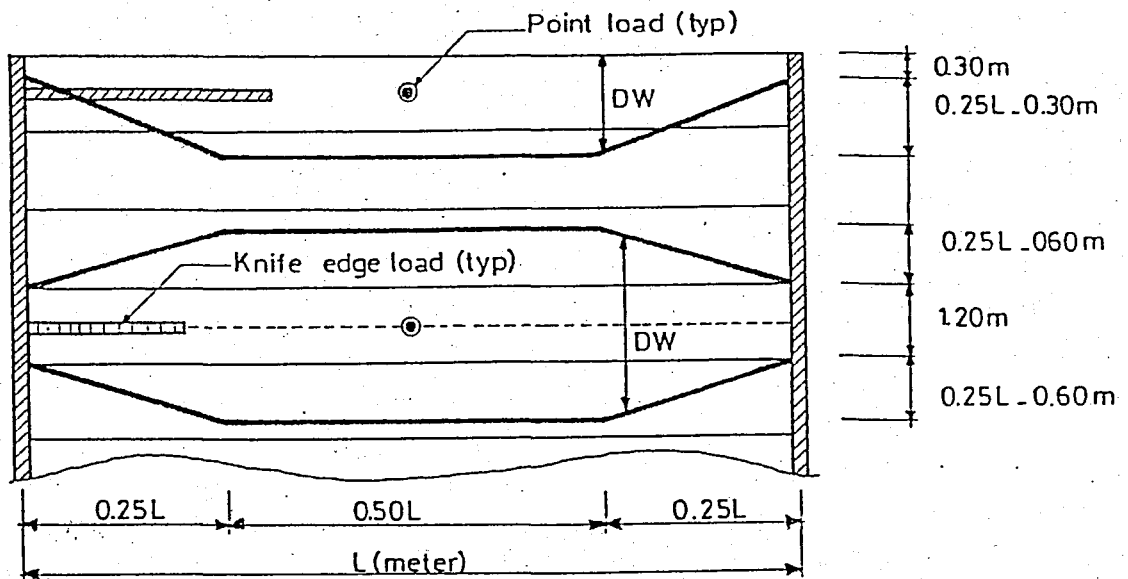

Fig. 30 Distribution of irregular loads (Method A)

In method B (Ref. 11), however, the distribution width is constant throughout the span length of the slab. Therefore, the load distribution calculations are much easier. Based on extensive testing by hollow core precast slab manufacturers (Ref 11), the maximum point loads allowed on slabs with various thicknesses, are given in Table 8. The locations of point loads are shown in Fig. 31. In case, the point loads, or their limiting points of application exceed the values given in this table, either the loads should be reduced, or the thickness of the slab should be increased. Points of interest about the interpretation of test results may be summarised as follows:

- 1- Values are based on a factor of safety of $n=2$, and a capacity reduction factor of 0.9
- 2- Values for 15 cm, 20 cm, and 25 cm slabs, are extrapolated and not verified by test
- 3- Interpolation is allowed for double point loads, spaced between $e = 0.3\text{ m}$ and $e = 0.5\text{ L}$ apart.

TYPE OF LOAD	SLAB THICKNESS, cm			
	15	20	25	30
SINGLE POINT LOAD	4.0	6.5	8.7	11.3
DOUBLE POINT LOADS				
a) Spaced greater than 0.5 L	2.7	4.4	5.8	7.5
b) Spaced Less than 0.30 m	2.0	3.3	4.4	5.6

Table 8- Maximum point loads allowed on hollow core slabs (ton)

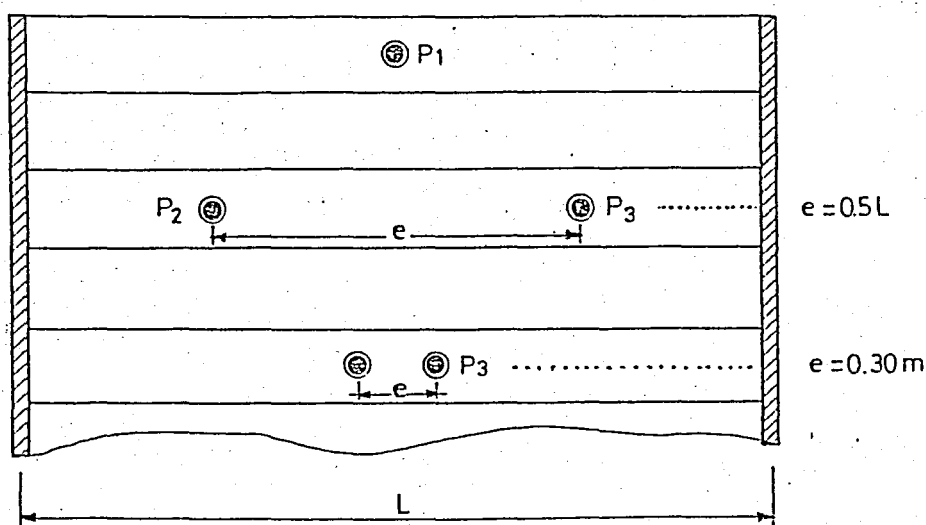

Fig. 31 Locations of maximum point loads

Width to span ratio effect on load distribution

In the study of distribution of non-uniform loads it was found that the midspan distribution width was a function of the width to span ratio. In most situations, this ratio will be much greater than 1.0. However, for the special cases where this ratio is less than 1.0, the basic distribution widths must be expressed as KL , where K is determined from the figure below. For edge loads, the factor K must be halved. Where central openings are present, a net width should be used for determining the width to span ratio.

Line Loads

Located on an interior slab :

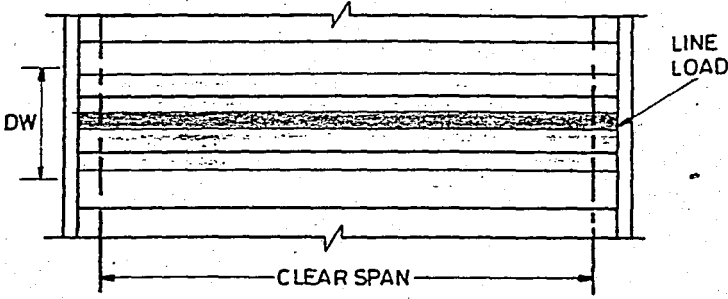

Located on an edge slab :

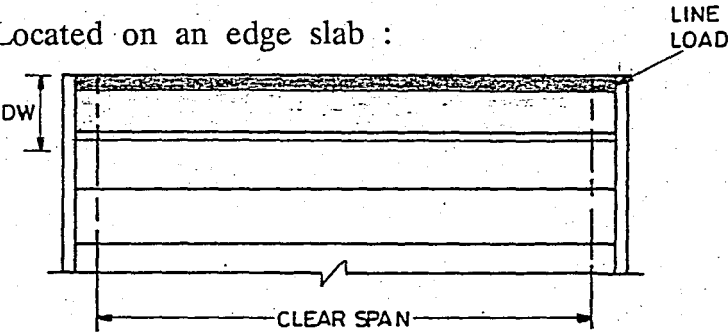

SLAB THICKNESS	DW
15	100
20	100
25	120
30	135

Concentrated Loads

Located on an interior slab :

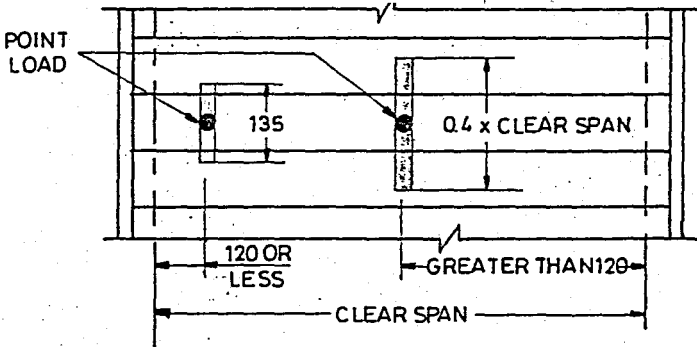

DW = Distribution width
(0.4 x clear span)

Located on an edge slab :

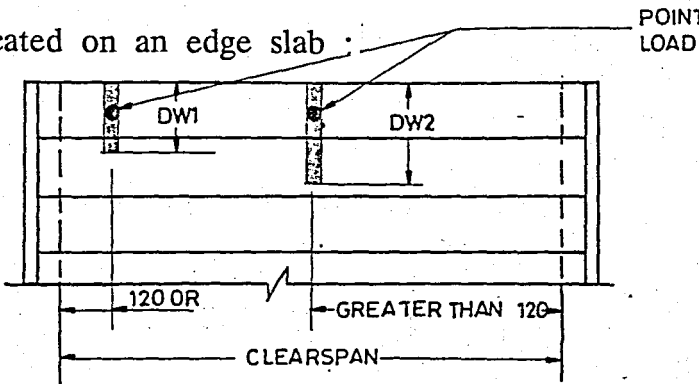

SLAB THICKNESS	DW ₁	DW ₂
15	100	100
20	120	120
25	135	150
30	135	180

Fig. 32 Distribution of irregular loads (Method B)

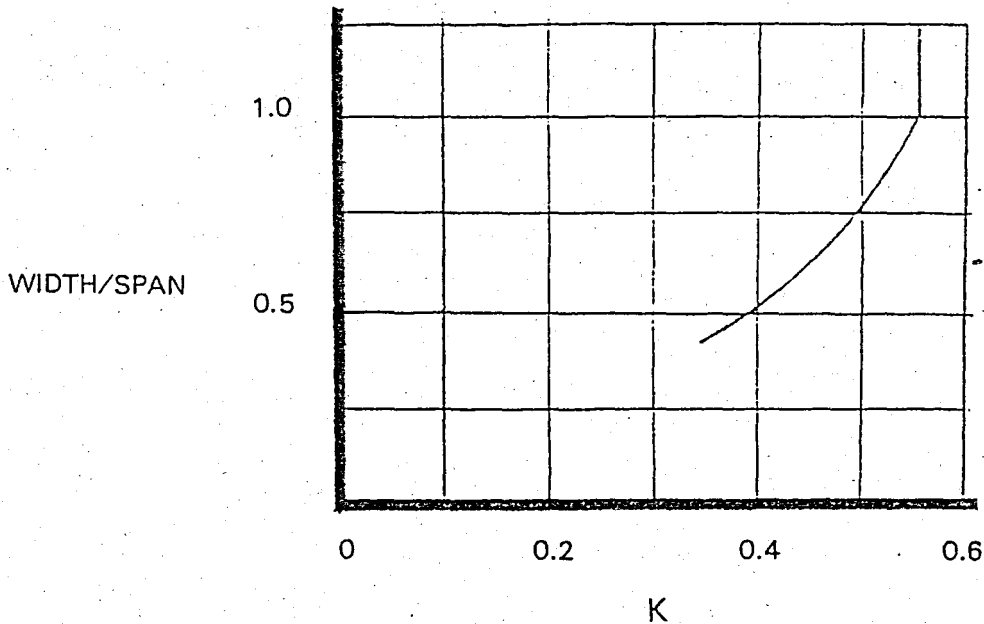

Fig. 33 Width to span ratio effect (Ref 12)

Example : Width to span ratio effect on load distribution

Given : 20 cm hollow core floor shown

Superimposed live load = 200 kg/m^2

Superimposed dead load = 50 kg/m^2

Plank dead load = 290 kg/m^2

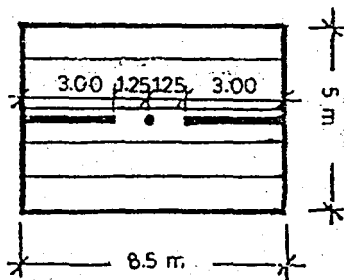

Wall load = 1050 kg/m DL

Wall load = 1650 kg/m LL

Concentrated load = 1250 kg DL

Concentrated load = 2000 kg LL

Problem :

Determine the equivalent effective design loadings to enable the floor slabs within the allowable distribution widths to carry the loads shown.

Solution :

$$\text{Width / Span} = 5/8.5 = 0.6, \text{ from chart (Fig. 33) } K = 0.44$$

Figure separately the distribution for the concentrated load, the wall load, and the uniform loads.

$$P_u = \frac{1.4 \cdot 1250 + 1.6 \cdot 2000}{0.44 \cdot 8.5} = 1323.5 \text{ kg/m}$$

$$W_u = \frac{1.4 \cdot 1050 + 1.6 \cdot 1650}{0.44 \cdot 8.5} = 1099 \text{ kg/m}^2$$

$$W_u = 1.4 (290+50) + 1.6 \cdot 200 = 796 \text{ kg/m}^2$$

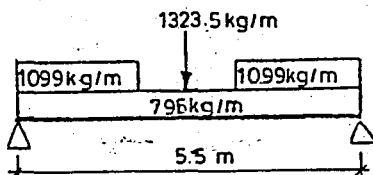

$$V_u = (1099 \cdot 3 \cdot 1.5 + 1099 \cdot 3 \cdot 7 + 1323.5 \cdot 4.25 + 796 \cdot 8.5 \cdot 4.25) / 8.5$$

$$V_u = 7341.75 \text{ kg/m}$$

$$M_u = 7341.75 \cdot 4.25 - 1099 \cdot 3 \cdot 2.75 - 796 \cdot 4.25 \cdot 2.125 = 14946.8 \text{ kgm /m}$$

7.2. Effect of Openings

Openings may be provided in hollow core systems by either saw cutting after a deck is installed and grouted, by forming or sawing the openings in the plant or by installing short slabs with steel headers. A typical header configuration is shown in Fig. 34 (Ref. 5). In laying out openings for a project, the least structural effect will be obtained by orienting the longest dimension of an opening parallel to a span, or by coring small holes to cut the fewest prestressing strands, or when several openings must be provided, aligning the openings parallel to the span to again cut the least number of prestressing strands.

For slab design, openings cause load concentrations which may be distributed over the slab system as discussed in the previous section. As with non-uniform loads, openings cause torsion in the slabs. Therefore, the

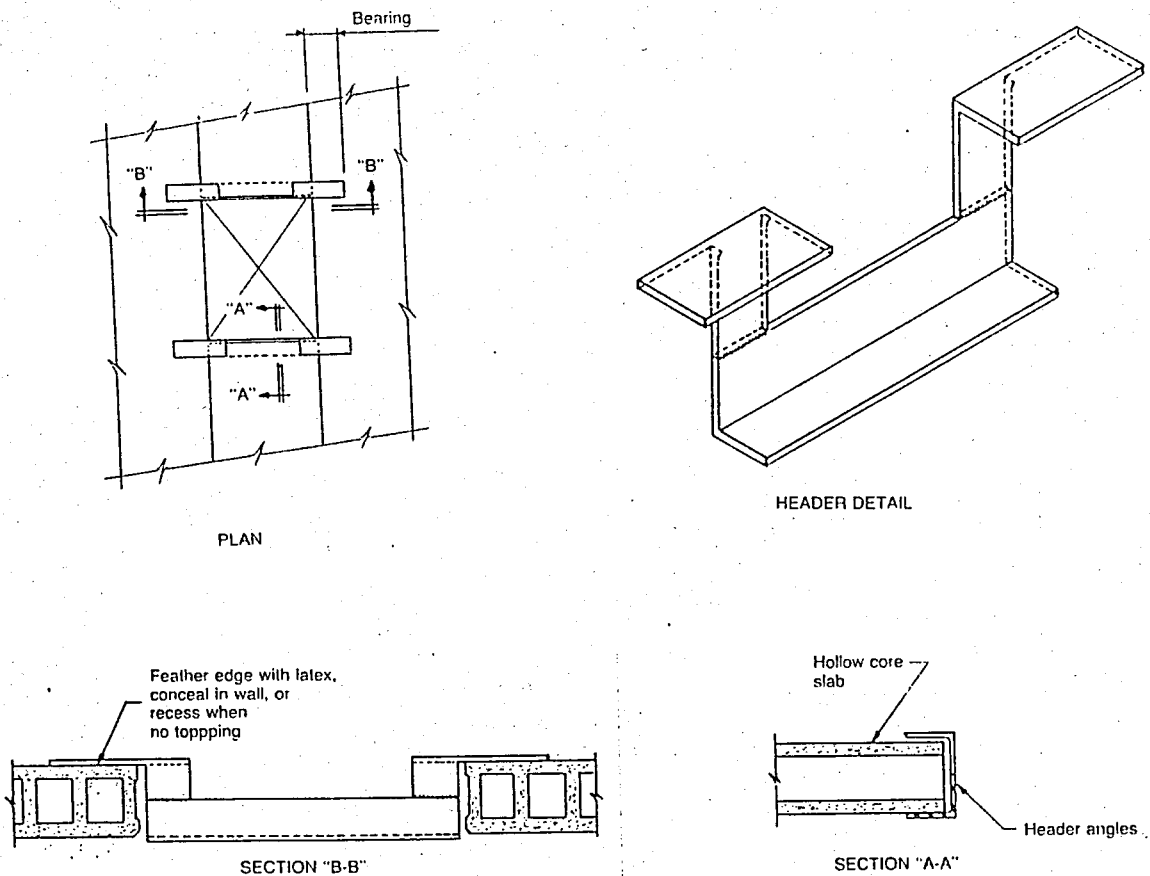

Fig. 34 Steel header detail at openings.

method of determining shear adequacy must also consider the effects of torsion on the shear stresses. In flexure the primary considerations are the length of the opening parallel to the span and the length of strand embedment available from the end of an opening to the point of maximum moment. Fig. 35 shows some general opening locations with suggested interpretations of the effective resisting slab width described before.

Fig. 35a depicts a relatively small opening located 1 at midspan. In flexure, the load from the short slabs can be resisted by slabs within $0.25l$ on each side of the opening. As a guideline, if an end of the opening shown is not closer to the support than $3/8l$, there will be no special considerations for shear design with only uniform loads.

Fig. 35b shows a similar condition where an opening is located with

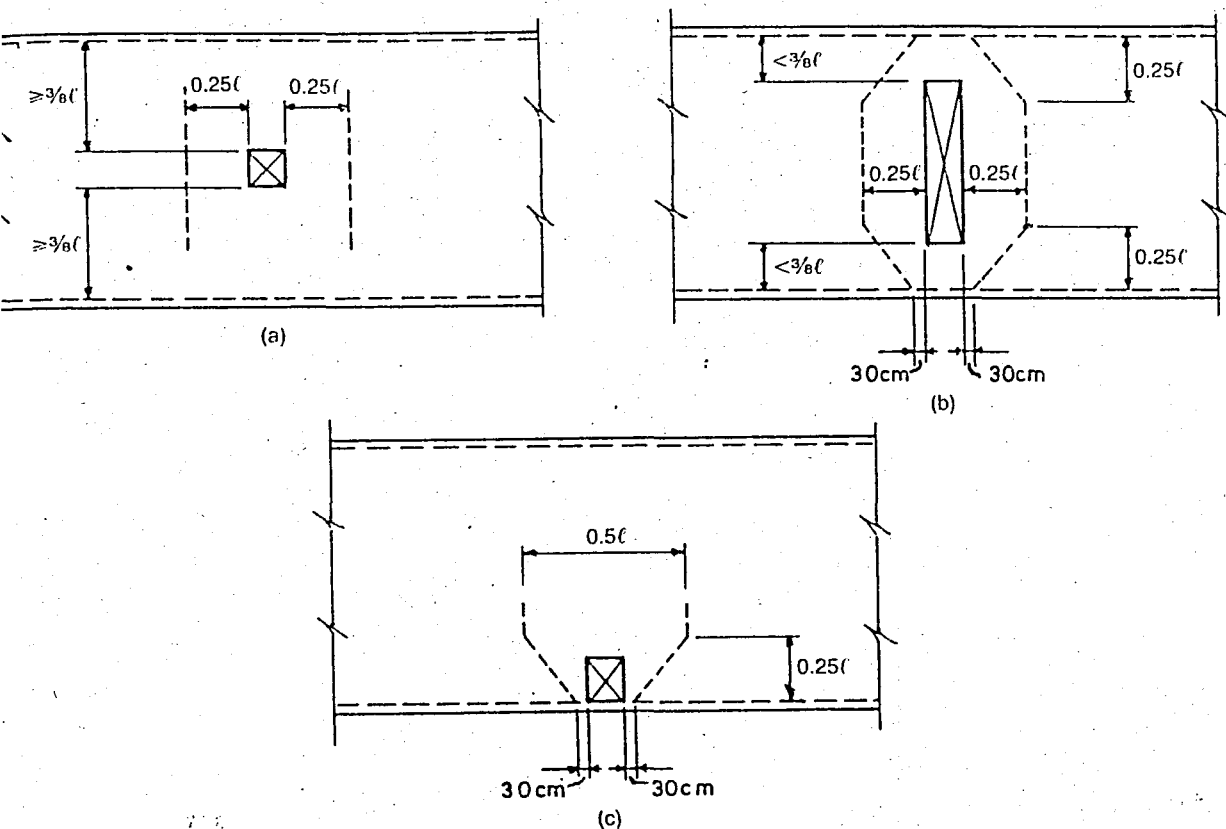

Fig. 35 Effects of Openings.

an end closer to the support than $\frac{3}{8}l$. In this case, shear is considered as though the opening created a free edge. That is, load from the short slabs or opening will be transmitted as an edge load to the adjacent slabs. The resulting torsion on the adjacent slabs requires that a reduced effective width at the support be used if torsional shear stresses are not directly calculated.

Fig. 35c depicts the extreme where an opening is located right at the end of a span. Again, the reduced shear width adjacent to the opening is required to reflect torsional shear stress. An end opening extending less than the lesser of $0.125l$ or 120 cm into the span may be neglected when considering flexure. However, some capacity reduction might be required for the slab with the opening when strand embedment length is less than full required development. When non-uniform loads are superimposed in the area of an end opening, these loads should be considered as being at a free edge for shear calculations.

Test results for openings :

Tests conducted by the manufacturers to determine the effects of openings in the midspan area of a hollow core system found out some results. These tests were one phases of the study of the distribution of non-uniform loads. For this test series, a central opening was defined as an opening located within the center quarter of the span and away from a free edge; the opening width used was 100 cm. The conclusions are as follows.

- 1- Central openings do not negate the ability of the hollow core plank system to distribute loads.
- 2- Central openings affect the bending distribution width by deducing the stiffness of the system. In checking width to span ratio, subtract the opening width from the system width.
- 3- Central openings do not affect the distribution width for shear design near a support.
- 4- Central openings essentially cause additional loads on the adjoining plank, which may be distributed as explained in the previous chapter.

Example : Load distribution around central openings

Given : 20 cm Hollow core floor shown

Plank dead load	= 290 kg/m ²
Superimposed dead load	= 50 kg/m ²
Superimposed live load	= 200 kg/m ²

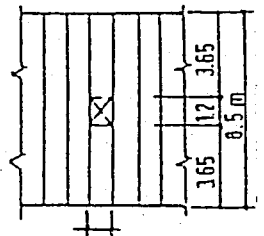

12

Problem :

Determine the design loads for the plank supporting the opening

Solution :

For flexural design, use a total distribution width of 0.55 L to distribute the load from the deck cut by the opening, and then add the factored uniform loads.

$$W_u = \frac{1.4 (290+50) + 1.6 \cdot 200 \cdot 1.2}{0.55 \cdot 8.5} = 204 \text{ kg/m}^2$$

$$W_u = 1.4 (290+50) + 1.6 (200) = 796 \text{ kg/m}^2$$

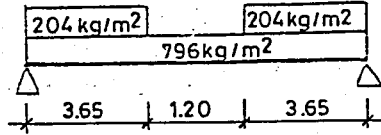

$$V_u = (204 \cdot 3.65 \cdot 1.825 + 204 \cdot 3.65 \cdot 6.675 + 796 \cdot 8.5 \cdot 4.25) / 8.5 = 4127.6 \text{ kg/m}$$

$$M_u = 4127.6 \cdot 4.25 - 204 \cdot 3.65 \cdot 2.425 - 796 \cdot 4.25 \cdot 2.125 = 8547.8 \text{ kgm/m}$$

No special shear design is required, since the opening is located in the middle quarter of the span.

7.3. Continuity Over Supports

Hollow core slabs are normally designed as part of a simple span system. However, continuity over supports can be achieved by placing reinforcing steel in the grouted keyways, in a composite structural topping, or by concreting bars into cores. Within limits, the result will be better control of superimposed load deflections and a lower requirement for positive moment capacity.

With reinforcing steel in either a composite topping or in cores, elastic moments with allowance for negative moment redistribution determine the amount of reinforcement required. Because of the relative efficiencies of positive prestressing steel and negative reinforcement steel, it is difficult to economically justify a continuous system design. When reinforcement is required at supports for reasons such as structural integrity ties or diaphragm connections, the reinforcement ratios are generally quite low, and therefore, develop little moment capacity. While this reinforcing may be considered in calculating service load deflections, it is recommended that full simple span positive moment capacity be provided for strength design unless moment curvature relationships existing at the support at ultimate loads are known.

Test results :

Tests conducted by the manufacturers were to determine whether mild reinforcement in a structural topping was an effective method to achieve continuity at plank ends. The most common application of this is increase in ultimate strength and a decrease in live load deflections. The test results may be summarised as follows :

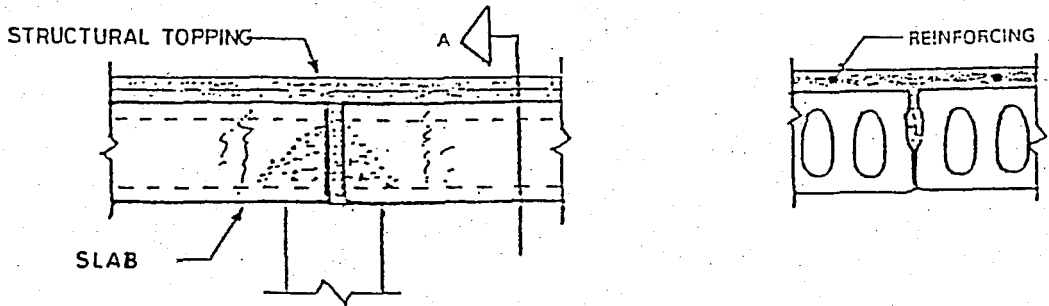

Fig. 36 Continuity at butt joint

- 1- Negative moments and corresponding increases in ultimate strength can be achieved by using mild reinforcement in a structural topping.
- 2- Care must be taken to insure adequate bond between the topping and the plank.
- 3- Mild reinforcing will yield, and moment redistribution can be accomplished with reinforcing ratios ranging from 0.0026 to 0.0044.
- 4- The mild reinforcement will cause a distribution of negative flexural cracking under loading, instead of one crack over the butt joint.

Example : Continuity over supports

Given : A 7.3 meter multispan 20 cm hollow core floor system with 5 cm structural topping :

Superimposed live load	= 488 kg/m ²
Plank dead load	= 290 kg/m ²
Topping	= 125 kg/m ²

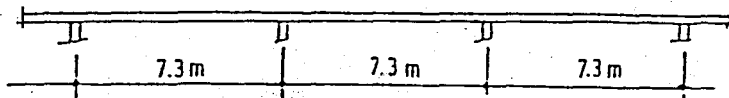

Problem :

Determine reinforcing requirements of plank and topping.

Solution :

For interior spans (exterior span approach is similar):

$$M_u = (1.4 \text{ DL} + 1.6 \text{ LL}) L^2/8$$

$$\begin{aligned} M_u &= [1.4 \times (290 + 125) + 1.6 \times 488] \times (7.3)^2 / 8 \\ &= 9071.3 \text{ kgm/m} \end{aligned}$$

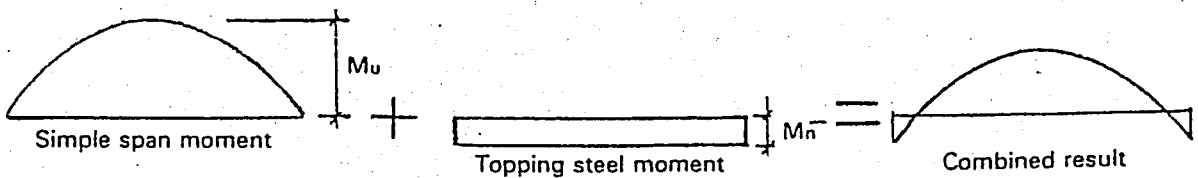

Select a plank series less than required by simple span moment alone, since the plank ultimate moment capacity must equal $M_u + M_n^-$ combined.

Try a plank from the load tables with $M_u = 6796 \text{ kgm/m}$

If $M_u + M_n^- = 6796 \text{ kgm/m}$, then $M_n^- = 6796 - 9071.3 = - 2275.3$

$$\phi M_n^- = \phi \cdot A_s \cdot f_y \cdot j_u \cdot d$$

$$A_s = \frac{2275.3}{0.9 \cdot 22.5} \cdot \frac{100}{0.9 \cdot 4200} = 2.97 \text{ cm}^2/\text{m}$$

This can be supplied by 7.5/150/150 as mesh reinforcement

7.4. Design of Cantilevers

Cantilever design in hollow core slabs differs from design with conventional precast members because of the production procedures used for hollow core slabs. Guidelines noted here are conservative and may be exceeded depending on the specific design requirement.

Because long line beds are used for the production of hollow core slabs, top prestressing strands may be economical only when full bed capacity is utilized. Even then, substantial amounts of prestressing strand may be used inefficiently because of debonding requirements. When top strands are used, the length of the cantilever is usually not sufficient to fully develop a strand. A reduced value for f is required and may be taken from Ref. 5. With either top strands or reinforcing, it may be necessary to debond portions of the bottom prestressing strand in the cantilever zone to help minimize the top tension under service loads. It is desirable to limit service level tensions in cantilevers so that uncracked section properties may be used to more accurately predict deflections. This tensile stress limit may vary for different systems used. For example, the practice with some dry cast systems is to limit tensile stresses to 70 N/mm^2 . In hollow core slab systems, the limit may be raised to $6 \sqrt{f'_c}$. As a rule of thumb, cantilever lengths falling in the range of 6 to 12 times the slab thickness will be workable within tension limits depending on the superimposed load and on individual producer's capabilities.

Design Calculations

When a hollow core slab is used as a cantilever, for a cantilevering length, more than three times the thickness of the slab, the concrete tensile stress at the top fibres, must be checked, not to exceed the maximum allowable stress level. The top fibre stress due to prestressing forces and the applied moment, is calculated as follows.

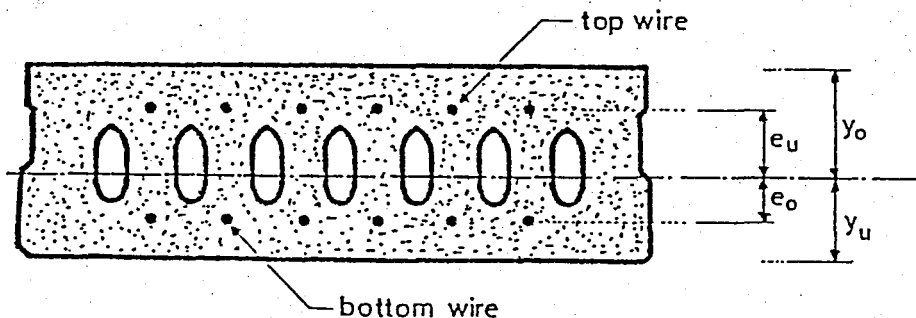

Fig. 37 Cross-section of a cantilever hollow core slab

1) Due to bottom strands :

$$f_1 = \alpha \beta \left(\frac{P_1}{A} - \frac{P_1 e_b y_o}{I} \right)$$

2) Due to top strands :

$$f_2 = \alpha \beta \left(\frac{P_2}{A} + \frac{P_2 e_b y_o}{I} \right)$$

3) Due to applied moment

$$f_3 = - \frac{M y_o}{I}$$

Total top fiber stress, f_{top} is the sum of all three stresses calculated above

$$F_{top} = f_1 + f_2 + f_3$$

which, if in tension, should not exceed the allowable tensile stress, prescribed by the code. Using the ACI (318-77) requirements, one can write ;

$$f_{top} < 0.5 \sqrt{f'_c} \text{ (N/mm}^2\text{)}$$

Definitions

The definitions of the notation used in the above expressions, are given below :

- α : Initial stress level ratio of the prestressing force, usually : 0.70
- β : Ratio of the prestressing force after losses, usually : 0.85
- P_1 : Total area of bottom prestressing strands, times the calculated stress in bottom prestressing steel at design load.
- P_2 : Total area of top prestressing strands, times the calculated stress in top prestressing steel at design load.
- A : Cross-sectional area of the hollow core slab element.
- I : Moment of inertia of the hollow core slab element
- e_t : Distance from neutral axis to the centroid of the top prestressing reinforcement.
- e_b : Distance from neutral axis to the centroid of the bottom

prestressing reinforcement.

- y_o : Fibre distance from top of slab to neutral axis.
 y_u : Fibre distance from bottom of slab to neutral axis.
 M : Maximum applied moment at the cantilever for the full width of the hollow core slab element, using the load factors.
 f_c : Specified compressive strength of slab concrete, N/mm^2

VIII- CONCLUSIONS

It has been demonstrated throughout this thesis that, there are a variety of possibilities to use hollow core slab and wall elements in the construction of both residential and commercial buildings.

These elements, when combined with a properly designed structural framework, represent an ideal solution for prefabricated systems, possessing excellent qualities in strength, durability, speed in erection and convenience in design.

Basic Advantages of the Hollow Core System

The basic advantages of the hollow core system from the view of the owner, contractor and designer, may be summarized as follows :

Advantages to the Owner

- Initial construction cost is low, because the hollow core system offers considerable economy over the conventional systems.
- Maintenance costs are very low, because the hollow core elements are made of relatively very durable high strength concrete. Further these elements are not susceptible to rust, rot and other deterioration.
- There is a quicker start of income due to shorter construction time arising from a very speedy erection.
- Hollow core systems have very excellent fire ratings, therefore the fire hazard and the corresponding fire insurance rates are relatively very low.
- Hollow core elements have very excellent heat insulation parameters, resulting in relatively very low heating and cooling costs.
- Last but not the least, the owners will be more than happy since, the hollow core systems have very good sound resistance characteristics.

Advantages to the Contractor

- The contractor will be able to have relatively much faster turnover of his projects due to shorter construction time.
- The hollow core system minimizes also the overhead costs because there are fewer construction crews to coordinate.
- The construction scheduling is much easier, more flexible and more definitive because the deckwork space is readily available for the subsequent crews.

Advantages to the Designer

- The hollow core systems allow the designer to achieve a higher standard and maximum required function. Therefore, the client is very satisfied to obtain a higher value for minimum cost.
- The designer has freedom for exterior architectural expressions.
- It is very easy to do space planning because of hollow core elements' capability of extending large spans without the obstruction of any shear walls or columns.
- The hollow core slab elements contain excellent hiding places for the installation systems like the electricity, piping, etc.
- Structural analysis and design is easier, since the wall and slab elements are standard items conveniently connected to the shear walls or frames.

Considering all the advantages inherent to the hollow core prefabricated system, it is believed that it will constitute a very efficient tool in the near future, in overcoming the problem of shortage of housing in Turkey.

R E F E R E N C E S

- 1- Anonymous, "Afet Bölgelerinde Yapılacak Yapılar Hakkında Yönetmelik", İmar ve İskan Bakanlığı, Deprem Araştırma Enstitüsü, Resmi Gazete No. 15260, June 9,1975.
- 2- Anonymous, "Building Code Requirements for Reinforced Concrete," ACI 318-1983.
- 3- Anonymous, "Uniform Building Code", International Conference, of Building Officials, Whittier, CA, 1979.
- 4- Anonymous", building Code Requirements for Prestressed Concrete, Öngerilmeli Beton Yapıların Hesap ve Yapım Kuralları, Türk Standartları, TS 3233, Şubat 1979.
- 5- John B. Henry, "Manual for the Design of Hollow Core Slabs", Prestressed Concrete Institute, Chicago, Illinois, USA, 1985.
- 6- Handbook of Concrete Engineering, Mark Fintel, Prestressed Concrete, James R. Libby 1974.
- 7- Standard Handbook for Civil Engineers, Merritt, Concrete Design and Construction, Charles H. Thornton and I. Paul Lew.
- 8- Anonymous, "CPCI Design Manual" The Canadian Prestressed concrete institute, 85 Albert Street, Ottawa, Ontario K1P 6A4.
- 9- Martin L.D., and Korkosz, W.J., "Connections for Precast Prestressed Concrete Buildings". Technical Report No 2, Prestressed Concrete Institute (PCI), Chicago, Illinois, March, 1982.
- 10- Semih S. Tezcan, "Use of Panelton Prefabricated Elements in Housing Construction". "13th Regional Seminar on Earthquake Engineering", Turkish National Committee for Earthquake Engineering, Ataköy C-Motels, Istanbul, Turkey September 14-24, 1987.

- 11- Anonymous, "Spancrete Specifications", Spancrete Industries, Inc., 10919 West Bluemound Rd, Milwaukee, Wisconsin S3226, USA.
- 12- Anonymous, "Spancrete Research Notes", Spancrete Industries Inc., 10919 West Bluemound Rd, Milwaukee, Wisconsin S3226, USA.
- 13- Anonymous, "Specifications for Structures to Be Built in Disaster Areas", Turkish Government Ministry of Reconstruction and Resettlement, Earthquake Research Institute, Ankara, July, 1975.
- 14- Anonymous, "Design of Multi-Storey Precast Concrete Structures", Thomas Telford Ltd, Telford House, Po Box 101, 26-34 Old Street, London EC1P 1JH, England, 1986