

SUBJECT POSITIONS, CASE CHECKING AND EPP IN COMPLEX NOUN
PHRASE CONSTRUCTIONS IN TURKISH

ASLI GÜRER

BOĞAZIÇI UNIVERSITY

2010

SUBJECT POSITIONS, CASE CHECKING AND EPP IN COMPLEX NOUN
PHRASE CONSTRUCTIONS IN TURKISH

Thesis Submitted to the
Institute for Graduate Studies in the Social Sciences
in partial fulfillment of the requirements for the degree of

Master of Arts
in
Linguistics

by
Aslı Gürer

Boğaziçi University

2010

Thesis Abstract

Aslı Gürer, “Subject Positions, Case Checking, and EPP in Complex Noun Phrase Constructions in Turkish”

This study discusses Nominative/Genitive subject case checking in CNPCs, in certain complement and adjunct clauses in Turkish. We analyze the structural properties of CNPCs as higher order compounds and the syntactic mechanism involved in Nominative/Genitive subject case checking and EPP which is crucial for understanding subject movement operations.

The basic claim of this thesis is that Nominative/Genitive case checking syntactic structures are surface variants of the same projection with the difference attributed to features inserted at phase heads in line with Features as Case licenser approach (Hiraiwa 2005). Nominal or verbal features inserted at phase heads determine the nature of the complement domains and also the case marker on the subject. This analysis has the advantage that it assumes the same case licensing mechanism for Nominative/Genitive subjects without appealing to different functional projections like *nP* or *DP* for genitive case licensing. This study further makes an analysis on the structural properties of all CNPCs realized in Turkish.

The structural properties proposed for CNPCs with Nominative/Genitive subjects together with the case checking mechanism also shed light on movement operations of the subjects. The subjects are not triggered to [Spec TP] for case or phi feature agreement purposes. Reconstruction in raising constructions, binding and NPI tests illustrate that in contrast to some other null-subject languages the subjects in Turkish do not show the properties of A' domain, with [Spec TP] remaining as the only possible target position for the subjects.

In conclusion case licensing and phi feature agreement mechanism show a regular pattern in Nom/Gen subjects and EPP exists as an independent mechanism in Turkish.

Tez Özeti

Aslı Gürer, “Türkçede Karmaşık Ad Öbeği Yapılarında Özne Konumları, İsmi Durumlarını Denetleme ve Genişletilmiş Yansıma İlkesi”

Bu çalışma Türkçede karmaşık ad öbeklerinde, belli bazı tümleç ve belirtecimsi cümlelerdeki Nominatif /Genitif özne hal değişimini tartışmaktadır. Üst düzen birleşik sözcük olarak karmaşık ad öbeği yapılarının yapısal özelliklerini, Nominatif/Genitif özne hal değişimindeki sözdizimsel mekanizmayı ve özne hareketi işlemlerini anlamada çok önemli olan Genişletilmiş Yansıma İlkesi’ni (GYİ) analiz ediyoruz.

Bu tezin esas iddiası Nominatif/Genitif özne hali durumuna izin veren sözdizimsel yapıların aynı gösterimin yüzey çeşitleri olduğudur ve farklılık ismin durumlarına izin veren özellikler yaklaşımı (Hiraiwa 2005) uyarınca evre başına eklenen özelliklerin farklılıklarına dayanmaktadır. Evre başlarına eklenen ad kökenli ya da eylemsi özellikler tümleç alanının niteliğini ve aynı zamanda özne üzerindeki ismin halini belirler. Bu analizin avantajı Genitif özne halini *nP* (küçük ad öbeği) ve *DP* (belirleyici öbek) gibi farklı görevsel/işlevsel gösterimlere başvurmadan, Nominatif/Genitif öznelere aynı ismin durumuna izin veren sözdizimsel mekanizmayı varsaymasıdır. Bu çalışma ayrıca Türkçede bulunan tüm karmaşık ad öbeklerinin yapısal özelliklerinin de analizini yapmaktadır.

Yapısal özellikleri verilen Nominatif/Genitif özneli karmaşık ad öbekleri yapıları için öne sürülen öbek yapısı ve ismin durumlarına izin veren mekanizma aynı zamanda öznelerin hareket işlemlerine de ışık tutmuştur. Özneler belirleyici zaman öbeğine ismin hali ya da sembol özellik uyumu için tetiklenmemektedir. Yükseltme kuruluşlarındaki yeni kurum testleri, bağlama ve eksi kutup unsurları testleri diğer gizli özne dillerin aksine Türkçede öznelerin Ü’ alanı özelliklerini göstermediğini anlatmaktadır ki bu da belirleyici zaman öbeğini özne hareketi için mümkün olan tek hedef yer kılar.

Sonuç olarak ismin durumuna izin vermek ve sembol özellik uyumu mekanizması Nominatif/Genitif öznelerde değişmez bir örüntü gösterir ve Genişletilmiş Yansıma İlkesi (GYİ) Türkçede bağımsız bir mekanizma olarak vardır.

ACKNOWLEDGMENTS

First, I owe my deepest gratitude to my thesis advisor Prof. Dr. A. Sumru Özsoy, without whose guidance and support this thesis would not have been possible. I thank her for her continuous guidance and encouragement at every stage of this study which enabled me to complete this thesis successfully.

An equal share of appreciation goes to Assoc. Prof. Dr. Aslı Göksel and Assist. Prof. Dr. Balkız Öztürk Başaran for their useful comments on the thesis. Assoc. Prof. Dr. Aslı Göksel was welcoming and supportive during the study and she provided me with valuable comments and questions that helped me to improve this thesis. I would like to thank Assist. Prof. Dr. Balkız Öztürk Başaran for her encouragement and valuable comments on many of the issues in the thesis.

I am greatly thankful to my friends Hayriye Kayka, Semra Baturay and Derya Nuhbalaoğlu for being a source of encouragement. I also thank my teacher colleagues Demet Şahin, Ayça Samut, Elif Topaloğlu and Ebru Tanrıyakul who shared not only their judgments but also the pleasure over completion of each chapter in the thesis. Their constant support and encouragement gave me strength.

Last but not the least, I would like to thank to my family. I am indebted to my parents İsmail and İpek Gürer who instilled in me the faith that I can achieve. I also thank my sister Neslihan and my brother Oğuz, for their endless support throughout the study.

CONTENTS

CHAPTER 1: INTRODUCTION	1
1.1 Aim	1
1.2 Turkish Facts	2
1.3 Theoretical Framework	5
1.3.1 External Merge (EM) and Internal Merge (IM).....	6
1.3.2 Phase Heads	7
1.4 Organization of the Thesis	13
CHAPTER 2: CNPCs AND COMPOUND FORMATION IN TURKISH	15
2.1 Introduction	15
2.2 Compound Formation Rules in Turkish	21
2.2.1 Co-occurrence Restrictions on Possessive Markers and Compound Marker.....	24
2.2.2 Omission of the Genitive Possessor and Neutralization of the Possessive Markers	27
2.3 CNPCs as Higher Order Compounds	35
2.4 The Position of the Genitive DP in CNPCs	37
2.4.1 Dialect A and B	40
2.4.1.1 Negative Polarity Items	42
2.4.1.2 Subject Verb Agreement	47
2.4.1.3 Scrambling	49
2.5 NP-GEN NP-POSS and NP-GEN NP-CM Constructions	54
2.6 Summary	58
CHAPTER 3: CASE LICENSING IN TURKISH	59
3.1 Some Properties of Nominative, Genitive, and Accusative Subjects in Turkish	61
3.1.1 Complement Clauses	63
3.1.2 Adjunct Clauses	68
3.1.3 Relative Clauses	71
3.1.4 Complex Noun Phrase Constructions	74
3.2 Nom/Gen Subject Case in Turkish	76
3.2.1 Movement Analysis for Nominative Subjects	78
3.2.1.1 Verbal Agr as Nominative Case Licenser	78
3.2.1.2 Mood and Epistemic Modality as Nominative Case Licenser	80
3.2.1.3 Phi Complete C and T as Nominative Case Licenser	83
3.2.2 Base Generation Analysis	84
3.2.2.1 AgentP as Nominative Case Licenser	84

3.2.3 Movement Analysis for Genitive Subjects	89
3.2.3.1 Nominal Agr as Genitive Case Licenser	89
3.2.3.2 External D Head as Genitive Case Licenser	96
3.2.3.3 Nominal C as Genitive Case Licenser	100
3.2.3.4 <i>n</i> Head as Genitive Case Licenser	103
3.3 Summary	108
CHAPTER 4: SUBJECT MARKING: GEN/NOM CASE LICENSING IN TURKISH.....	109
4.1 Introduction	109
4.2 Gen/Nom Subject Case Licensing in CNPCs	109
4.3 Case Licensing	113
4.3.1 Different Functional Projections as Case Licenser	113
4.3.1.1 Nominal AGR as Case Licenser in CNPCs	114
4.3.1.2 External D Head as Case Licenser in CNPCs	116
4.3.1.3 Nominal C as Case Licenser in CNPCs	120
4.3.1.4 <i>nP</i> as Case Licenser in CNPCs	122
4.3.2 Base Generation Approach	126
4.3.3 Features as Case Licenser	130
4.3.3.1 Supercategorial Theory of CP/DP Parallelism	130
4.3.3.2 Features as Case Licenser in CNPCs	136
4.3.3.3 Pseudo Gen/Nom Alternation	143
4.4 Movement or Base Generation Analysis	147
4.5 Turkish Complement and Adjunct Clauses	151
4.5.1 Complement Clauses	151
4.5.2 Adjunct Clauses	157
4.5.3 Relative Clauses	162
4.6 Summary	165
CHAPTER 5: EPP, CASE CHECKING AND SUBJECT POSITIONS.....	167
5.1 Introduction	167
5.2 EPP as a Universal Principle	170
5.2.1 Dispensing with EPP through other Syntactic Mechanisms	171
5.2.2 EPP in Null-Subject Languages	174
5.3 Subject Position above <i>vP</i> Domain	178
5.3.1 TP Domain	179
5.3.1.1 Quantifier Phrases	180
5.3.1.2 Reconstruction Test	183
5.3.1.3 NPIs and Binding Facts	186
5.4 Is EPP redundant or not?	190
5.5 Summary	192

CHAPTER 6: CONCLUSION 194
APPENDIX 200
REFERENCES 207

CHAPTER ONE

INTRODUCTION

1.1.Aim

The aim of this thesis is to investigate the nature of the syntactic mechanism involved in subject case licensing in complex noun phrases in Turkish. It has been observed in Turkish linguistics literature that Turkish licenses Nominative/Genitive subject case in complex noun phrase constructions, in complement clauses, in certain adjunct clauses and relative clauses. The thesis will present an analysis of these constructions with the aim of determining the nature of the case licensing mechanism in each instance.

The questions that will be addressed in the thesis are given below:

- What are the structural properties of complex noun phrases in Turkish?
- Is Genitive subject in the same position with the nominative subject at the point in the derivation where case is checked?
- Does case checking involve movement or long distance agreement?
- If movement, which functional projections are possible landing sites for the subjects?
- Does genitive subject move to a higher projection than nominative subject? If yes, which one?

- Can the movement of the subjects in Turkish be explained by Case Filter and/or EPP, as formulated within the MP?
- Is it possible to discard EPP?

The analysis of subject case licensing proposed in this thesis will have implications for the universality of the two mechanisms within the generative framework, i.e. EPP (Chomsky 1981) and Case Filter (Chomsky 1980, 1981). The analyses will also have applications for the functional categories and the phrase structure of Turkish.

1.2 Turkish Facts

In Turkish main clauses, subjects bear Nominative case which has no overt marker. The agreement markers on the verb are verbal agreement markers.¹

- (1) Ben alışveriş yap-tı-m.
 I-NOM shopping do-PAST-1SG
 ‘I did shopping.’

¹ There are two sets of agreement markers in Turkish corresponding to nominal and verbal agreement.

Verbal Agreement markers		Nominal Agreement markers	
singular	plural	singular	plural
Ben git-ti-m.	Biz git-ti-k.	Ben-im ev-im ve araba-m	Biz-im ev-imiz ve araba-mız
I go-PAST-1SG	we go-PAST-1PL	I-GEN house-POSS and car- POSS	we-GEN house- POSS and car- POSS
Sen git-ti-n.	Siz git-ti-niz.	Sen-in ev-in ve araba-n	Siz-in ev-iniz ve araba-nız
you go-PAST-2SG	you go-PAST-2PL	you-GEN house-POSS and car-POSS	you-GEN house-POSS and car- POSS
O git-ti-Ø	Onlar git-ti-ler.	O-nun ev-i ve araba-sı	Onlar-in ev-leri ve araba-ları
he go-PAST-3SG	they go-PAST-3PL	he-GEN house-POSS and car-POSS	they-GEN house-POSS and car- POSS
‘I/we/you/she/he/it/they went.’		‘my/your/her/his car house and car’	‘our/your/their houses and cars.’

In subordinate clauses, on the other hand, there are constructions in which Nominative/Genitive case marked subjects are possible. The structures in (2a-d) are Complex Noun Phrase Constructions (CNPC) in Turkish in which Genitive/Nominative case variation can be observed.

(2) a. Sen iş-ten çık-tı-n dedikodu-su herkes-in
 you-NOM job-ABL leave-PAST-2SG rumor-CM everybody-GEN
 ağz-ın-da.
 mouth- 3POSS-LOC

b. Sen-in iş-ten çık-tı-ğ-ın dedikodu-su herkes-in
 you-GEN job-ABL leave-NOM_{AGR} rumor- CM everybody-GEN
 ağz-ın-da.
 mouth-3POSS-LOC

‘The rumor that you left your job is talked about by everybody.’

c. Sen-in dün gece bayıl-dı dedikodu-n
 you-GEN yesterday night faint-PAST-3SG rumor-2SGPoss
 çok konuş-ul-du.
 very speak-PASS-PAST

‘Your rumor that s/he fainted last night is talked about a lot.’

d. Sen-in saatlerce koş-tu-n iddia-sı sadece bir yalan.
 you-GEN for hours run-PAST-2SG claim-CM just a lie
 ‘The claim (about you) that you ran for hours is just a lie.’
 ‘Your claim that ‘you ran for hours’ is just a lie.’

In (2a) the complement of the head noun shows inflectional properties of a main clause. The embedded predicate is fully inflected for tense and verbal agreement markers. The embedded subject bears Nominative case marker.

The complement of the head noun in (2b) has the inflectional properties common to a subordinate clause with a nominalizer. The embedded predicate appears with the nominalizer –DIK and nominal agreement markers. The embedded subject bears Genitive case.

(2c) is similar to (2a) with respect to the fact that the embedded predicate is inflected for tense. Default agreement marker, i.e. third person agreement marker, appears on the embedded predicate. The agreement marker on the head noun agrees in person with the genitive case marked nominal.

In (2d) the embedded predicate is inflected with tense and verbal agreement markers as is the case in (2a). The DP nominal bears Genitive case. Compound marker -(s)I appears on the head noun.

Chapter two illustrates the structural properties of CNPCs including the ones in (2a-d). Chapter three presents Turkish facts and previous studies on Nom/Gen subject case licensing in Turkish literature which leads to a new syntactic analysis of subject case checking in CNPCs in chapter four.

Now we turn to the theoretical framework in section 1.3 which will be relevant for the discussions in the following chapters.

1.3 Theoretical Framework

The theoretical framework that the arguments are based on is the Minimalist Program (MP) as proposed by Chomsky (1995, 1999, 2000, 2001, 2005, 2007, 2008). The aim of the MP is to better understand and formulate a principled account of Faculty of Language (FL).

Chomsky (2008) argues for the Strong Minimalist Thesis (SMT) “which holds that language is an optimal solution to interface conditions that FL must satisfy; that is language is an optimal way to link sound and meaning. . .”

From Government and Binding Theory (GB) to the MP there has been a continuous research to explain FL through levels of representation and structure building operations. Although the MP is based on GB, it seeks for the most economical computational system.

Government and Binding Theory (GB) assumes four levels of representation: Deep Structure (DS), Surface Structure (SS), Logical Form (LF) and Phonetic Form (PF). DS is the level where the grammatical function and the thematic roles of the lexical items are the same. SS is the level where Case is assigned and displacement properties are observed. PF and LF are interface levels namely the derivation sent out from SS is assigned phonetic interpretation at PF and semantic interpretation at LF.

Within the MP, these levels are reduced to LF and PF which are indispensable and required without a stipulation. DS and SS are subsumed under the operation ‘Merge’. Thus MP not only attempts to find ‘an optimal way to link sound and meaning’ but also does this in the most elegant, natural, and economical way.

In the following sections basic tenets of the MP relevant to the thesis will be focused on.

1.3.1. External Merge (EM) and Internal Merge (IM)

In the MP, the computational system does not take lexical items randomly from the lexicon rather it takes a numeration which is a set of lexical items. There is further internal organization within a numeration known as sub-array (Chomsky, 2000). Each sub-array has only one phase head.

$$\text{Numeration} = \{ \{_{\text{Phase 1}} X, A, B, C \}, \{_{\text{Phase 2}} Y, D, E, F \} \}$$

According to these assumptions the computational system takes the numeration above from the lexicon. The numeration is composed of two sub-arrays each headed by a phase head indicated here as *X* and *Y*. Lexical items in the derivation have phonological, semantic, and formal features. These can be interpretable features which are specified in the lexicon or uninterpretable features which must be valued in the course of the derivation.

Full Interpretation (FI) requires each feature at LF and PF to be interpreted appropriately, otherwise the derivation crashes. However at PF, formal features cannot be interpreted so if there is a syntactic feature relevant for phonological component it should be eliminated before PF. Not all syntactic features are interpretable at LF; the uninterpretable features must be deleted by LF. Interpretable features on the other hand are legible at LF so they need not be deleted.

There is a set of operations making the derivation proceed in a smooth way: Merge and Agree. Merge has two instances: External Merge (EM) and Internal Merge (IM), the latter also known as the operation ‘Move’. Chomsky (2005) defines the differences between EM and IM in the following way: “EM yields generalized argument structure (theta roles, the “cartographic” hierarchies, and similar properties); and IM

yields discourse-related properties such as old information and specificity, along with scopal effects.” IM is like EM in that it comes free and it is not an “imperfection” of language.

The other operation is Agree. Under this operation the probe with uninterpretable features values its features with interpretable features of a matching goal.

If the probe with uninterpretable features also has an EF then IM applies and the probe attracts the goal with a matching feature to its specifier position. If the probe with uninterpretable feature does not have an EF then Agree applies and the probe with uninterpretable features values its features in accordance with FI and does not attract the goal to its specifier position.

Within the MP there was a shift from sub-arrays to phase heads in terms of internal organization (Chomsky, 2005). Only phase heads are the locus of all features and instead of Lexical Arrays (LA) they determine the transfer points to Interface Levels. In the next section there will be a focus on phase heads.

1.3.2. Phase Heads

In the MP, Chomsky (2005) proposes that there are two phases: CP and vP .²

Chomsky (2000) suggests ‘propositionality’ as a criterion for phasehood, namely C and v are independent units in terms of interface properties. Transitive vP has ‘full argument structure’ and C has ‘tense and force’ properties. The second criterion for phasehood is allowing movements to the edges namely having reconstruction sites.

² Based on the parallelism between CP and DP structure, Hiraiwa (2005) takes DP also as a phase head.

Phases are the basic derivational units. The computational system takes one phase into derivation. When the derivation moves to the next phase, the complement domain of the previous phase is sent to Spell-Out, thus is no longer available for computation. This simplifies the computational system; however, edges are exempted from this process to allow for the movement of the syntactic objects for operations in subsequent phases.

Phase Impenetrability Condition (PIC) checks the structure in small steps namely phase by phase. Given that each phase is sent to Spell-Out, MP assumes Multiple Spell-Out, rather than a single Spell-Out.

As a result of cyclic Spell-Out a probe cannot have access to earlier phases as stated in Phase Impenetrability Condition (PIC):

Phase Impenetrability Condition: (Chomsky, 2000)

“The domain of H is not accessible to operations outside HP; only H and its edge are accessible to such operations. The edge being the residue outside of H’, either specifiers (Specs) or elements adjoined to HP.”

Given the structure $[_{ZP} Z \dots [_{HP} \alpha [H YP]]]$ with H and Z the heads of phases the following tree structure in (3) shows the search domain of ZP, XP and HP.

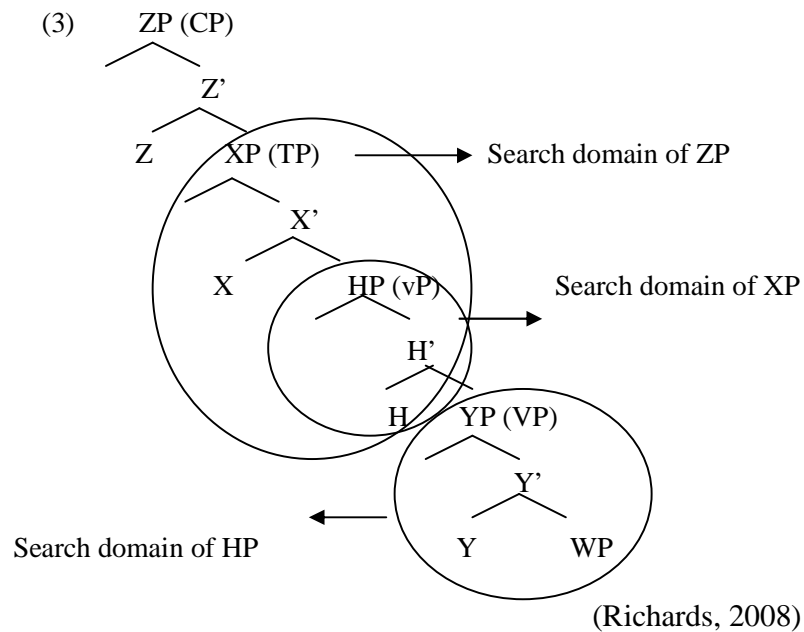

According to this formulation of PIC the complement of vP is not accessible to non-phase TP. The search domain of TP is restricted to v and its specifiers. However T in some unaccusative and passive constructions long distance agrees with the DP in the complement domain of vP in English.

(4) a. [C [T be likely [Expl to arrive a man]]]

b. There is likely to arrive a man. (Chomsky, 2001)

The expletive moves to [Spec TP] and deletes the EPP feature of T. However the expletive cannot delete the uninterpretable phi features of T as it is phi incomplete. Then probe T Agrees with the goal in the VP domain and values its uninterpretable phi

features and as a reflex of this values the case feature of the object DP. However the fact that T can probe into unaccusative ν P challenges the PIC stated above.

Thus Chomsky (2000) proposed that unaccusative and passive ν P is not a phase as Agree between T and the DP in the complement domain of VP is not expected under PIC. Chomsky (2001) distinguishes strong phases (C and ν) and weak phases (unaccusative and passive ν Ps). According to this assumption the structure exemplified in (3) does not pose a challenge to PIC since unaccusative ν P is not a strong phase. Therefore T can probe for a goal in this domain.

However, Legate (2003) indicated that reconstruction effects, quantifier raising and parasitic gap tests provide evidence for the phasehood of unaccusative and passive ν Ps. Unaccusative and passive ν Ps have reconstruction sites similar to transitive ν Ps showing that there is movement to the edges for the operations in the higher phases.

Moreover such a distinction between strong and weak phases cannot explain agreement between T and DP in the complement domain of a transitive ν P in Icelandic.

(5) Henni ??/* leiddist/leiddust stárnir.
Her(D) bored(Dflt.)/bored(3Pl.) boys(Nom.D.Pl.)
'She found the boys boring.' (Sigurðsson 1996, 26)

In this example matrix T agrees with the nominative object although the ν P phase intervening between TP and VP is a strong one.

Based on these problems with the first formulation, PIC was revised in the following way.

Given the structure $[_{ZP} Z \dots [_{HP} \alpha [_H YP]]]$;

“The domain of H is not accessible to operations at ZP; only H and its edge are accessible to such operations.” (Chomsky, 2001)

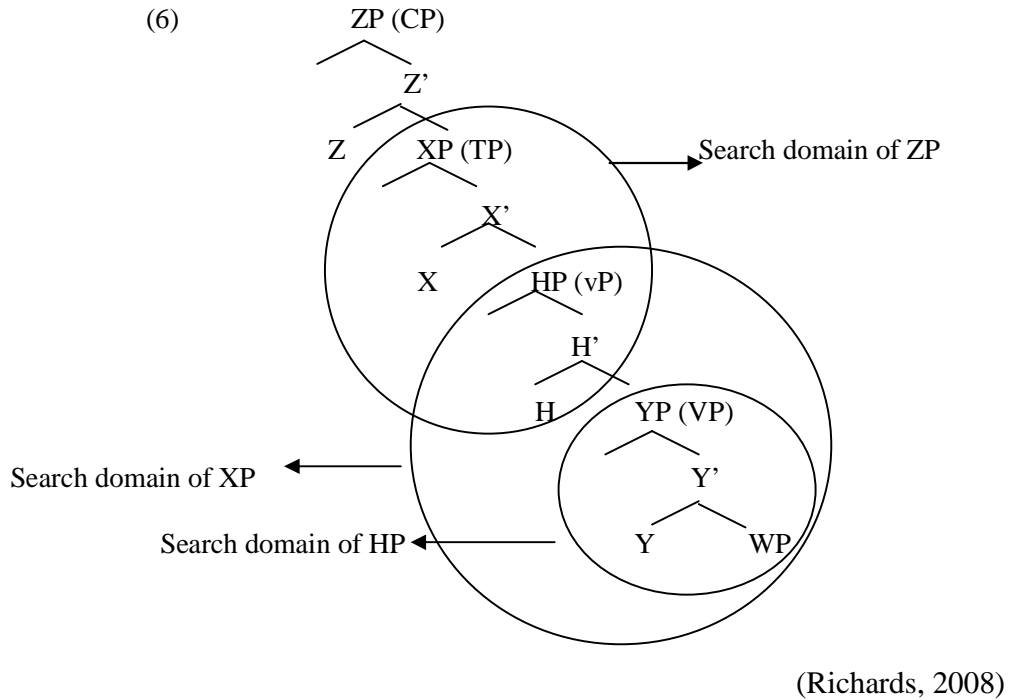

Based on the configuration above the search space of TP is extended. T can not only probe into νP but also VP domain.

Examples (4) and (5) no longer challenge PIC as the complement domain of νP is accessible to TP until the Merge of the next phase which is CP.

As for the syntactic nature of the phase heads, it is assumed that all phi features and Tense are in C. These are transmitted to T once CP is merged. Thus phi features and Tense are not intrinsic to T but derivative. A similar analysis is made for νP and VP projections. All relevant features are in ν and these are transmitted to V.

Phase heads have Agree feature and Edge Feature (EF). Agree feature of C is inherited by T and Agree feature of *v* is inherited by V. Edge feature of the relevant head, on the other hand, attracts an XP to [Spec CP] or [Spec *v*P]. If T inherits EF from C together with Agree feature it also attracts the goal to its specifier position. That is why a DP is raised to [Spec TP] or an expletive is merged. However, EF of C cannot attract an XP raised to [Spec TP]. It must raise from its base generated position.

A- versus A-' movement distinction is determined not on the basis of the structural position of the moving phrases but on the basis of how they are derived. Merge position initiated by EF is an A' position and the others are A position.

(7) John saw Mary.

Under these assumptions, the derivational steps of the structure in (7) can be illustrated in the following way.

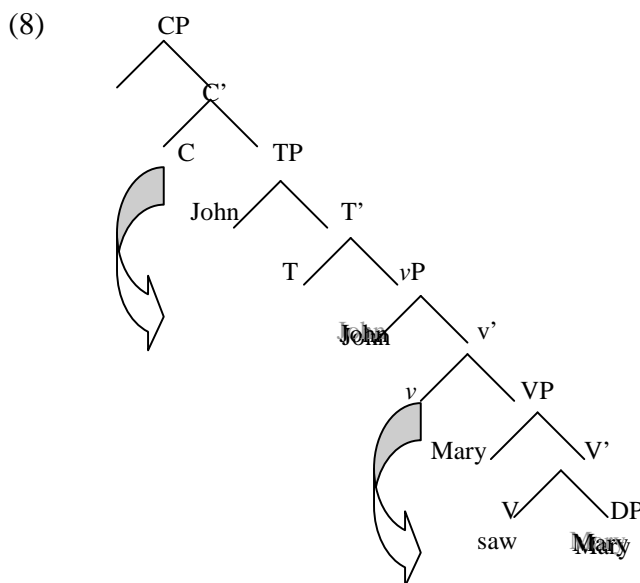

The derivation starts with the ν P phase. Once ν P is merged V inherits the relevant features from ν and its EF. V^0 attracts the goal DP ‘Mary’ to its specifier position. As V^0 then undergoes head movement to ν position movement of the DP to [Spec VP] isn’t detected. As stated in PIC the complement domain of ν P is not sent to Spell-Out until the Merge of CP.

The next phase is CP. Once CP is merged T inherits Tense and phi features from C and C-T probes for a goal with matching interpretable phi features to value its uninterpretable phi features. According to PIC the specifier position of the ν P phase is accessible to CP phase.

C-T values its uninterpretable phi features and as a reflex of this, the C-T probe values the case feature of the goal DP as nominative. As T has also inherited C’s EF it also attracts the goal to its Spec position. Finally this phase is also sent to Spell-Out.

1.4 Organization of the Thesis

The first chapter has introduced the theoretical framework with a special emphasis on phase heads and case licensing mechanism within the MP which is relevant to the discussions in the following chapters.

Chapter II illustrates possible variants of Complex Noun Phrase Constructions (henceforth CNPCs) in Turkish with a special focus on the structural properties of CNPCs as higher order compounds. The discussion on structural properties of CNPCs will extend to a syntactic analysis of subject case licensing in CNPCs in chapter four.

Chapter III presents the distribution of Nominative and Genitive subject case licensing in complement and adjunct clauses, relative clauses, and complex noun phrase

constructions in Turkish. The second part of this chapter focuses on former accounts on Turkish Nom/Gen subject case licensing within the generative framework (Kural 1993, Kornfilt 2003, Aygen 2002, Öztürk 2005, Ulutaş 2008, Miyagawa 2008). These studies are illustrated under the classification of Base Generation Analysis and Movement Analysis.

Chapter IV proposes ‘Features as case licenser’ analysis for CNPCs in Turkish. This chapter discusses syntactic derivation of CNPCs in Turkish the structural properties of which are presented in chapter two. Implications of this analysis for complement and adjunct clauses and relative clauses are also discussed in the second part of this chapter with pre-conditions specified for Turkish.

Chapter V deals with the nature of EPP in contrast to other syntactic operations such as Case/Agree in Turkish and investigates the target position of Nom/Gen subject movement operations.

Chapter VI presents the main questions raised and answered in the current study with the contributions, implications for the theory and suggestions for future studies.

CHAPTER TWO

CNPCs AND COMPOUND FORMATION IN TURKISH

2.1 Introduction

This chapter illustrates CNPCs in Turkish and examines their structural properties. The main concern of the chapter is to illustrate all the possible variants of CNPCs in Turkish with their structural properties. This discussion is crucial for understanding the syntactic mechanism involved in Nominative/Genitive case licensing in CNPCs which is the focus of chapter four.

CNPCs in Turkish have compound structure, which will be shown in detail in section 2.2. The following structures in (1a-d) exemplify some CNPC variants in Turkish.

(1) a. Sen yeni bir ev-e taşın-mış-sın söylenti-si gerçek değil.
you-NOM new one house-DAT move-PAST-2SG rumor-CM true not
'The rumor that you moved to a new house is not true.'

b. Sen-in sınav-ı geç-e-me-diğ-in haber-i biz-i üz-dü.
you-GEN exam-ACC pass-ABIL-NEG-AGR_{NOM} news-CM we-ACC upset-PAST
'The news that you couldn't pass the exam upset us.'

c. Sen-in dün gece bayıl-dı dedikodu-n
 you-GEN yesterday night faint-PAST-3SG rumor-2SGPoss
 çok konuş-ul-du.
 very speak-PASS-PAST
 ‘Your rumor that s/he fainted last night is talked a lot.’

d. Sen-in saatlerce koş-tu-n iddia-sı sadece bir yalan.
 you-GEN for hours run-PAST-2SG claim-CM just a lie
 ‘The claim that you ran for hours is just a lie.’
 ‘The claim (about you) that you ran for hours is just a lie.’

Nominative/Genitive subject case variation in (1a-b) will be discussed in Chapter four. This chapter deals with the structural properties of CNPCs given in (1c-d). However CNPC variants with Genitive case marked nominals are not restricted to (1c-d). All the possible variations are illustrated in (2a-e).

(2) a. sen-in dün gece bayıl-dı iddia-n
 you-GEN yesterday night faint-PAST-3SG claim-2SGPoss
 ‘your claim that s/he fainted last night.’
 *‘your claim that you fainted last night’

b. sen-in iflas et-miş-sin haber-in
 you-GEN bankruptcy get-PAST-2SG news-2SGPoss
 ‘your news that ‘you went bankrupt’
 * ‘your news that you went bankrupt’

c. sen-in gizlice evlen-di söylen-ti-si
 you-GEN secretly marry-PAST-3SG rumor-CM
 ‘the rumor (about you) that you got married secretly’
 ‘your rumor that s/he got married secretly’

d. sen-in saatlerce koş-tu-n iddia-sı
 you-GEN for hours run-PAST-2SG claim-CM
 ‘the claim (about you) that you ran for hours.’
 ‘your claim that ‘you ran for hours’’

e. sen-in_i her zaman başar-ır-ım_i laf-ın_i
 you-GEN always succeed-AORIST-1SG remark-AGR_{NOM}
 ‘your remark ‘I always succeed’’
 *‘your remark about me that I always succeed’

The Genitive DP in (2e) is interpreted to be co-referential with the *pro* in the complement clause. The embedded predicate bears first person singular agreement marker but the referent of *pro* is the same with the second person genitive nominal.

According to the grammaticality judgment test we have done, which will be discussed in detail in section 2.4, the CNPCs given in (2a-d) have two different analysis based on two dialects in Turkish: Dialect A and B.

Speakers of Dialect A do not interpret the Genitive DP as the subject in any of the sentences above. As illustrated below in (3a-d), in these CNPCs there is *pro* in the

embedded clause that may or may not be co-indexed with the Genitive DP for Dialect A speakers. This point will be discussed in detail in sections 2.4 and 2.5.

(3) a. sen-in_i [*pro*^{*}_{i/j} dün gece bayıl-dı_j] iddia-n_i

b. sen-in_i [*pro*^{*}_{i/j} iflas et-miş-sin_j] haber-in_i

c. sen-in_i [*pro*_{i/j} gizlice evlen-di_{i/j}] söylen-ti-si

d. sen-in_i [*pro*_{i/j} saatlerce koş-tu-n_{i/j}] iddia-sı

Dialect B speakers on the other hand interpret the Genitive DP as the subject in the embedded clause when co-indexation is possible with the embedded predicate. For Dialect B speakers Genitive/Nominative alternation is possible in some CNPCs although this is restricted to certain constructions and/or speakers which will be discussed in detail in section 2.4. This is illustrated below in (4a-d).

(4) a. [hiçkimse-nin_i iflas et-me-miş-tir_i] haber-in_j
 nobody-GEN bankruptcy get-PAST-2SG news-2SGPoss
 ‘your news that ‘nobody went bankrupt’

b. [sen-in_i saatlerce koş-tu-n_i] iddia-sı_j
 you-GEN for hours run-PAST-2SG claim-CM
 ‘the claim that you ran for hours.’

c. *[sen-in_i gizlice evlen-di_i] söylenti-si_j
 you-GEN secretly marry-PAST-3SG rumor-CM
 ‘the rumor that you got married secretly’

d. *[sen-in_i dün gece bayıl-dı_i] iddia-n_j
 you-GEN yesterday night faint-PAST-3SG claim-2SGPoss
 ‘the claim that you fainted last night’

When the agreement markers on the embedded predicate agree in person with the genitive nominal as illustrated in (4a-b), Dialect B speakers interpret Genitive DP as the subject in the embedded clause. It will be shown in section 2.4 why (4c-d) cannot be realized in Dialect B.

The CNPCs given in (1a-b) repeated below as (5a-b) are parallel in structure to simple compounds in Turkish.

(5) a. [[sen yeni bir ev-e taşın-mış-sın] söylenti-si]
 you-NOM new one house-DAT move-PAST-2SG rumor-CM
 ‘the rumor that you moved to a new house’

b. [[sen-in sınav-ı geç-e-me-diğ-in] haber-i]
 you-GEN exam-ACC pass-ABIL-NEG-AGR_{NOM} news-CM
 ‘the news that you couldn’t pass the exam’

c. [[yarış] araba-sı]

race car-CM

'race car'

In (5a) there is a finite clause and in (5b) a proposition as the complement of the head noun which bears compound marker -(s)I. In (5c), which is a simple compound, the complement is a simple noun and as is the case in (5a-b) the head noun bears compound marker -(s)I.

In what follows, we will take a look at the structural properties of simple compounds and CNPCs in Turkish. Section 2.2 demonstrates formation rules for simple compounds which are relevant for the discussion on structural properties of CNPCs in section 2.3. Section 2.4 presents the grammaticality judgment test and the analysis of CNPCs in two different dialects. The discussion in this section has implications for the compound structures and for subject case licensing which is the focus of the fourth chapter. Section 2.5 discusses the position of the Genitive nominal in the DP domain contrasting these structures with genitive-possessive constructions.

2.2 Compound Formation Rules in Turkish

-(s)I compounds and Genitive-Possessive constructions are two nominal constructions in Turkish.¹

-(s)I Compounds: In Turkish when a compound contains two nouns, the head is inflected with -(s)I which is exemplified below.²

¹ There is another nominal construction in Turkish which consists of a complement and head without a suffix. The following is an example of this construction.

N-Ø N-Ø

(1) altın bilezik

‘golden bracelet’

Dede (1978), Schaaik (2002) and Göksel and Kerslake (2005) label this N-N sequence as bare compounds. Göksel and Kerslake (2005) suggest that bare compounds are used when ‘the first noun specifies the sex, profession or nationality of the person denoted by the second noun; when the first noun specifies the material from which the item denoted by the second noun is made and in the names of some dishes and street names.’ In the thesis we will restrict the analysis to the constructions which bear a compound marker or possessive agreement marker on the head noun.

² We have represented the nominal compounds under DP projection; however in Turkish literature there are some other analyses that question the existence of DP as a functional projection in Turkish. Öztürk (2005) argues that in Turkish there are no overt or covert determiners that will be evidence for the existence of a DP projection.

N N-CM
 (6) diş fırça-sı
 tooth brush-CM

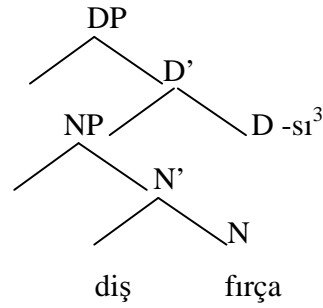

The suffix $-(s)I$ which attaches to the head noun has been labeled as the compound marker by some researches (Schaaik 1996, 2001, 2002, Schroeder 1999) and as the possessive marker $-s(I)$ by others (Lewis 1967, Underhill 1976, Gencan 1979, Banguoğlu 1998).

³ The compound marker $-(s)I$ has the following allomorphic variations. The set in (1a) illustrates the variants of the compound marker when attached to a word ending in a vowel and the set in (2a) illustrates the variants of the compound maker when attached to a word ending in a consonant.

(1) a. ütü masa-sı
 ironing table-CM
 ‘ironing table’

(2) a. yarış at-ı
 race horse-CM
 ‘race horse’

b. kış uyku-su
 winter sleep-CM
 ‘hibernation’

b. su top-u
 water polo-CM
 ‘water polo’

Note that the high vowel in the compound marker $-(s)I$ undergoes vowel harmony when preceded by a rounded vowel as illustrated in (1b-2b).

Genitive-Possessive Constructions: genitive-possessive constructions are made up of a genitive marked possessor as the modifier and a possessed entity as the head marked with a possessive marker. ⁴

- (7) a. Ben-im ev-im
 I-GEN book-1SG Poss
 ‘My book’
- b. Ayşe-nin ütü-sü
 Ayşe-GEN iron-3SG Poss
 ‘Ayşe’s iron’

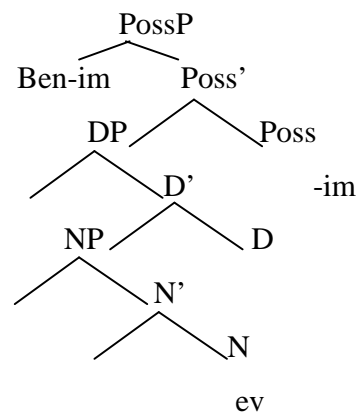

The possessive suffix on the head noun agrees in person and number with the genitive possessor; it is first person singular in (7a) and third person singular in (7b). Note that third person possessive suffix and compound marker have the same form but as the distribution facts indicate they do not have the same function. Third person possessive

⁴ We have adapted the tree structure proposed by Arslan-Kechriotis (2006) for the possessive phrases which select DP as a complement as illustrated below.

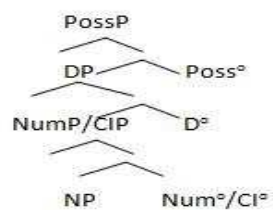

Arslan-Kechriotis (2006, 84)

Arslan-Kechriotis (2006) suggests that ‘when there is no possessive phrase a PossP is not posited.’

suffix appears when there is a third person genitive possessor but compound marker – (s)I appears on the heads of all -(s)I compounds.⁵

2.2.1 Co-occurrence Restrictions on Possessive Markers and Compound Marker

-(s)I compounds can be embedded under a genitive-possessive construction. The structures given (8a-b) exemplify -(s)I compounds which are restricted by genitive possessors.

(8) a. Ben-im diş fırça-m

I-GEN tooth brush-1SG Poss

‘My tooth brush’

b. Ayşe-nin çay bahçe-si

Ayşe-GEN tea garden-3SG Poss

‘Ayşe’s tea garden’

⁵ Yüксеker (1987) suggests that possessive compounds and syntactic possessives (Gen-Poss constructions) have similar structures based on structural and semantic similarities between the two constructions.

NP-Gen NP-Poss
(1) a. kalem-Ø silgi-si
pencil eraser-POSS

‘an eraser attached to a pencil’

NP-Gen NP-Poss
b. kalem-in silgi-si
pencil-GEN eraser-POSS

‘this/the pencil’s eraser’

Yüксеker (1987) argues that complements of the heads in both possessive compounds and syntactic possessives bear Genitive case. In syntactic compounds Genitive case is realized overtly while in possessive compounds it is null.

In (8a) -(s)I compound ‘diş fırçası’ is restricted by first person genitive possessor and in (8b), -(s)I compound ‘çay bahçesi’ is restricted by third person genitive possessor.

Note that when -(s)I compound is restricted by a genitive possessor, it is the possessive agreement marker rather than the compound marker that appears on the head noun (Dede 1978, Göksel 1988, Schaaik 2001).

(9) a. *Sen-in çay bahçe-si-n
 you-GEN tea garden-CM-2SGPoss

‘Your tea garden’

b. Sen-in çay bahçe-n
 you-GEN tea garden-2SG Poss

‘Your tea garden’

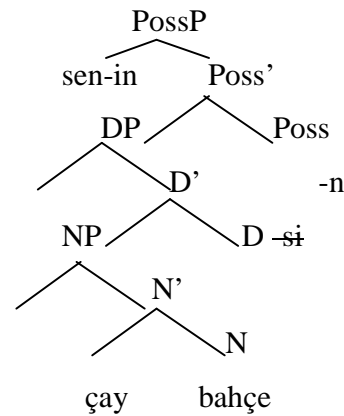

The co-occurrence of the compound marker and the possessive suffix yields ungrammaticality as the ungrammaticality of (9a) above indicates. Schaaik (2001, 2002) suggests ‘late expression of the compound marker’ according to which the compound marker -(s)I is not attached at the level of compound formation proper but that it is attached only in those cases where the compound functions as an NP’. Schaaik (2002) proposes that (10a) represents Turkish compound formation which can be an input for further formations while (10b) represents -(s)I compound functioning as an NP.

(10) a. Noun₁ - Noun₂ -

b. Noun₁ . Noun₂ – CM

According to this formulation, in (8a-b) nominal compounds ‘*çay bahçe*’ and ‘*diş fırça*’, without a CM, function as the head of the genitive-possessive construction and as there is a genitive possessor, possessive suffix is attached. In (6) on the other hand, CM is attached on the head noun as the nominal compound functions as an NP.

Kornfilt (1984) analyses the co-occurrence restriction of the compound marker and the possessive suffixes under morpheme deletion analyses. She suggests that CM is a non-alternating suffix namely it does not change in form but possessive markers are alternating suffixes as they change in form. If there is a sequence of a non-alternating and an alternating suffix as in (11), the non-alternating suffix must be deleted.

(11) *Sen-in çay bahçe-si-n

CM-Possessive Suffix

The structure is predicted to be ungrammatical because the compound marker which is the non-alternating suffix in this sequence is not deleted. Note that of the two formulations for compounds given in (10), Kornfilt’s analysis is in line with the formulation in (10b) as the CM is assumed to be attached at the level of compound formation proper.

2.2.2 Omission of the Genitive Possessor and Neutralization of the Possessive Markers

When the possessed entity is not compared with something else, the possessor is not focused or does not introduce a new topic (Göksel & Kerslake 2005); genitive possessor can be omitted otherwise genitive possessor is overtly expressed as the examples in (12a-b) indicate.

(12) a. (Ben-im) Ödev-im çok zor. Ben-a yardım et.

(I-GEN) homework-1SGPoss very difficult. I-DAT help do

‘My homework is very difficult. Help me with my homework.’

b. Ben-im ödev-im sen-in ödev-in-den daha zor.

I-GEN homework-1SGPoss you-GEN homework-2SGPoss-ABL more difficult

‘My homework is more difficult than your homework.’

It is also possible to omit the possessive agreement markers on the head noun in simple genitive constructions with overt first or second person genitive possessors (Schroeder 1999, Öztürk 2001, Göksel and Kerslake 2005) and this is referred to as ‘neutralization’ of the possessive marker (Schroeder 1999).

Note that this is only possible when the genitive possessor is obligatorily overt and when the possessed entity is alienably related to the genitive possessor as exemplified in (13a-b).⁶ Neutralization of the possessive suffix is not allowed when genitive-possessive construction expresses body parts or relations between two entities (Schroeder 1999, Öztürk 2001) as the ungrammaticality of (13c-d) indicates.⁷

⁶ Possessive suffix can also be neutralized with some inalienable kinship terms and inalienable locations as illustrated in the examples below.

(1) a. Ben-im kız okul-u sev-mi-yor.
 My girl school-ACC like-NEG-PRES
 'My little girl (daughter) does not like the school.'

b. o zaman anne-m yönetici-ydi bizim apartman-da
 that time mother-AP.1SG caretaker-PST1 our apartment-LOC
 'At that time, my mother was the caretaker of our department.'

(Schroeder 1999,112-113)

The possessor bears Genitive case but possessive suffixes on the head nouns are neutralized.

⁷ Öztürk (2001) suggests that genitive constructions with agreement differ in structure from genitive constructions without agreement in that the genitive nominal in genitive constructions without agreement are determiners. Öztürk (2001) bases her arguments on the following contrasting properties of the two constructions.

(i) non-agreeing genitive forms are not compatible with determiners while agreeing genitive forms are compatible with determiners.

(1) a. Ben-im bütün/her/birçok ev-im
 I-gen all/every/many house-1psg
 'all/every/many houses of mine'

b. * Ben-im bütün/her/birçok ev
 I-gen all/every/many house

(ii) movement of the constituents is allowed in agreeing genitive forms while this is not allowed in non-agreeing genitive forms.

(2) a. mavi araba-m ben-im
 Blue car-1p sg I-gen
 'my blue car'

b. *mavi araba ben-im
 Blue car I-gen

(13) a. Ben-im araba çok hızlı.

I-GEN car very fast.

‘My car is very fast.’

b. * ec araba çok hızlı.

car very fast

Intended reading: ‘My car is very fast.’

c. *ben-im göz

I-Gen eye

‘my eye’

d. *masa-nın örtü

table-gen cloth

‘the table cloth’

Similar to neutralization of the possessive agreement markers, there is another property of the nominal constructions in Turkish which has not been studied in the literature so far. When -(s)I compound is embedded under a genitive-possessive construction, in some cases on the head noun compound marker appears instead of possessive agreement markers. This is exemplified in (14a-b) below.

(14) a. Sen-in yarış araba-sı düşün-düğ-üm kadar hızlı değil.

you-GEN race car-CM think-DIK-AGR_{NOM} as much as fast not

‘Your race car is not as fast as I expected it to be.’

b. Ben-im diş fırça-sı çanta-da yok.
 I-GEN tooth brush-CM bag-LOC absent.

‘My tooth brush is not in the bag.’

In (14a) the genitive possessor is second person singular, in (14b) it is first person singular and hence on the head noun possessive agreement markers that agree in person with the genitive possessors are expected. However compound marker appears on the head noun instead of possessive agreement markers contrasting with the examples in (8a-b).

One possibility is to analyze these structures in a similar vein with genitive-possessive constructions as exemplified in (15) with the corresponding tree structure.

(15) a. Ben-im diş fırça-sı
 I-GEN tooth brush-CM
 ‘my tooth brush’

b. Ben-im diş fırça-m
 I-GEN tooth brush-1SGPoss
 ‘my tooth brush’

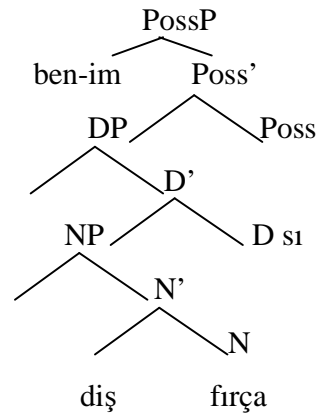

Under this analysis the occurrence of the compound marker in (15a) remains arbitrary as first person possessive agreement markers are expected on the head noun as is the case in (15b). Additionally, similar to the contrasts Öztürk (2001) suggests for genitive-

possessive constructions and genitive constructions with neutralized agreement markers, NP-GEN NP-CM constructions differ from genitive-possessive constructions.

In genitive-possessive constructions there is a thematic relation between the complement and the head noun but this is not necessarily the case in NP-GEN NP-CM constructions. In (16a) the owner of the race horse is interpreted to be the genitive nominal, while in (17a) the owner of the race horse is not necessarily the genitive nominal. In (17a) it is possible to interpret the horse as the speaker's favorite horse in the race or as the horse the speaker owns.

(16) a. Ben-im yarış at-ım

I-GEN race horse-1SGPoss

'my race horse'

b. Sen-in ve ben-im yarış at-ımız

you-GEN and I-GEN race horse-1PLPoss

'your and my race horse'

(17) a. Ben-im yarış at-ı

I-GEN race horse-CM

'my race horse'

'my (favorite) race horse'

b. Sen-in ve ben-im yarış at-ı

you-GEN and I-GEN race horse-CM

'your and my race horse'

When genitive nominals are co-ordinated as in (16b) and (17b), in genitive-possessive constructions, the head noun agrees in person with the co-ordinated nominals but compound marker appears on the head noun in co-ordinated NP-GEN NP-CM constructions.

Movement of the constituents is possible in genitive-possessive constructions, while this yields to ungrammaticality in NP-GEN NP-CM constructions.

(18) a. yarış at-ım ben-im
 race horse-1SGPoss I-GEN

b. *yarış at-ı ben-im
 race horse-CM I-GEN

Based on these differences we conclude that genitive-possessive constructions and NP-GEN NP-CM constructions differ in structure and propose the following tree structures as possible representations of NP-GEN NP-CM constructions.

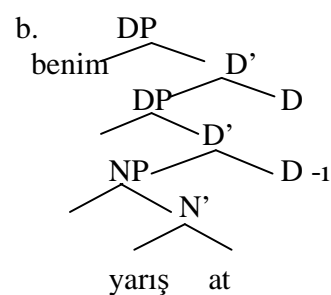
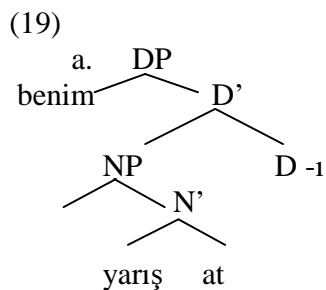

In both (19a-b) the genitive nominal occupies [Spec DP] position. (19a) is similar to a -(s)I compound while (19b) assumes another DP projection over -(s)I compound. As mentioned in section 2.2, compound marker is a non-alternating suffix and appears on the heads of all -(s)I compounds. There is not phi feature agreement with the D head and the nominal in [Spec DP] and hence genitive case on the nominal in [Spec DP] in (19a) is not expected. We suggest (19b) as the representation of NP-GEN NP-CM constructions. In section 2.5, we will give further evidence for the proposed tree structure.

According to the analysis proposed by Schaaik (2001, 2002) the formation rules given above for simple compounds are assumed to be the same for higher order compounds given in (20) below.

(20) a. kendisi-nin de onun yer-in-de aynı şey-i yap-acağ-ı duygu-su
 himself-gen too his place-p3s-loc same thing-acc do-fut-agr feeling-CM
 ‘The feeling that he too would do the very same thing in his place.’

(Schaaik 2001, 7)

b. Erkek-ler-in, “Kadın-lar ne istiyor-lar?” soru-su-na
 male-pl-gen woman-pl what want-pres-agr question-CM-dat

kafa patlat-tık-ları da bir gerçek.

brain-rack-pres-agr too a reality

‘That men rack their brains over the question “What do women want?” is a reality too.’

(Schaaik 2001, 1)

The constructions in (20a-b) are parallel in structure to simple compounds in that there is a complement and a head which bears the compound marker –(s)I. These structures are different from simple compounds with respect to the nature of the heads and complements. The head of the compound in (20a) is higher order noun which takes a complement that expresses a ‘proposition’ while the head in (20b) is again a higher order one which takes a clausal term as its complement.

Schaaik (2002) proposes the following terms as possible complement and head types.

	Complement	Head	Term
a) First order Terms	Çay tea ‘tea garden’	bahçe-si garden-CM	NP
b) Second Order Terms	Bir kitap yaz-ma a book write-INF ‘the idea to write a book’	fikr-i idea-CM	Predicational
c) Third Order Terms	Herşey tamam ol-duğ-u everything all right be-PRT1-P3S ‘The claim that everything is all right’	iddia-sı claim-CM	Propositional
d) Fourth Order Terms	Bir tane daha ist-er mi-ydi-niz One more want-PRES1 Q-PROJ1-2P ‘The question “Would you like another one?”	sual-i question-CM	Clausal

The structural properties are the same in First Order Terms to Fourth Order Terms but the complement and head types differ at each level. The next section focuses on the structural properties of CNPCs as higher order compounds.

2.3 CNPCs as Higher Order Compounds

The CNPCs in (1a-b), repeated below as (21a-b), are parallel in structure to simple -(s)I compounds in that there is a complement and a head which bears the suffix -(s)I. The CNPCs differ from simple -(s)I compounds in that the complement is not a first order entity, the complement expresses a proposition, or it is a clause.

(21) a. [[sen yeni bir ev-e taşın-mış-sın] söylenti-si]
 you-NOM new one house-DAT move-PAST-2SG rumor-CM
 ‘the rumor that you moved to a new house’

b. [[sen-in sınav-ı geç-e-me-diğ-in] haber-i]
 you-GEN exam-ACC pass-ABIL-NEG-AGR_{NOM} news-CM
 ‘the news that you couldn’t pass the exam’

Being analyzed as -(s)I compounds, it is possible to embed these structures under a genitive-possessive construction parallel to (7a-b). This is exemplified in (22a-b).

- (22) a. [ben-im [[sen yeni bir ev-e taşın-mış-sın] söylenti] -m]
 I-Gen you-NOM new one house-DAT move-PAST-2SG rumor-1SGPoss
 ‘my rumor that you moved to a new house’
- b. [Ayşe-nin [[sen-in sınav-ı geç-e-me-diğ-in] haber] -i]
 Ayşe-GEN you-GEN exam-ACC pass-ABIL-NEG-AGR_{NOM} news-3SGPoss
 ‘Ayşe’s news that you couldn’t pass the exam’

In (22a-b), -(s)I compound is embedded under a genitive-possessive construction. As the compound is restricted by first person genitive possessor in (22a) and third person genitive possessor in (22b), possessive agreement markers that agree in person with the genitive possessors appear on the head nouns.

The co-occurrence of the possessive agreement markers with the compound marker in (23) yields ungrammaticality as is the case with simple compounds.

- (23) *[ben-im [[sen yeni bir ev-e taşın-mış-sın] söylenti-si] -m]
 I-Gen you-NOM new one house-DAT move-PAST-2SG rumor-CM-1SGPoss
 ‘my rumor that you moved to a new house’

The tree structures of the examples in (22a-b) are given in (24a-b) below.

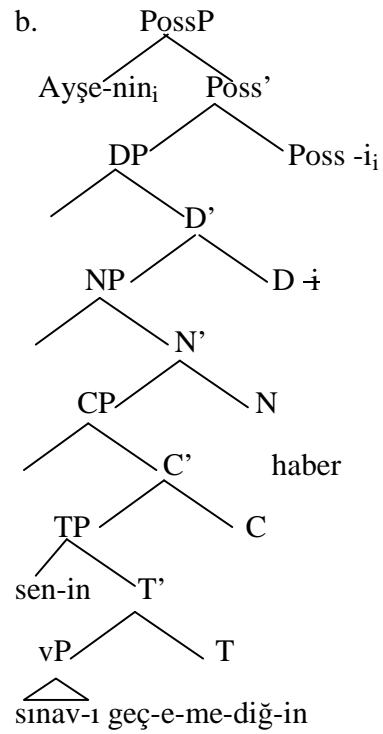
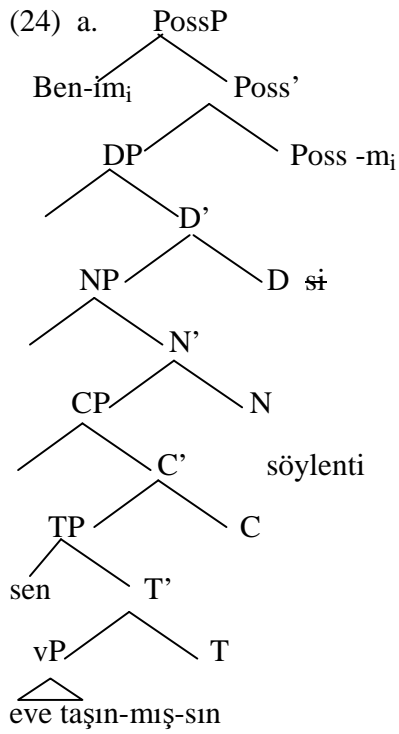

In the next section we turn to the analysis of the nominal constructions which have the representation of NP-GEN NP-POSS or NP-GEN NP-CM.

2.4 The Position of the Genitive DP in CNPCs

As illustrated in section 2.1, the following CNPCs may have two structures and can be represented in two different ways. According to the first representation given in (25a-d), which represents Dialect A, the genitive DP is not the subject in the embedded clause in any of the sentences.

Dialect A

(25) a. sen-in_i [*pro**_{i/j} dün gece bayıl-dı_j] iddia-n_i
you-GEN yesterday night faint-PAST-3SG claim-2SGPoss
'your claim that s/he fainted last night'
*'your claim that you fainted last night'

b. sen-in_i [*pro**_{i/j} iflas et-miş-sin_j] haber-in_i
you-GEN bankruptcy get-PAST-2SG news-2SGPoss
'your news that 'you went bankrupt'
* 'your news that you went bankrupt'

c. sen-in_i [*pro*_{i/j} gizlice evlen-di_{i/j}] söylen-ti-si
you-GEN secretly get married-PAST-3SG rumor-CM
'the rumor (about you) that you got married secretly'
'your rumor that s/he got married secretly'

d. sen-in_i [*pro*_{i/j} saatlerce koş-tu-n_{i/j}] iddia-sı
you-GEN for hours run-PAST-2SG claim-CM
'the claim (about you) that you ran for hours.'
'your claim that 'you ran for hours'

In all the examples the genitive nominal is second person. In both (25a-b), the head noun is marked with possessive agreement markers that agree in person with the genitive nominal. The embedded predicate in (25a) bears third person agreement markers and the embedded predicate in (25b) is inflected with second person agreement

markers. Note that *pro* in the embedded clause cannot be co-indexed with the genitive nominal in both (25a-b).

In both (25c-d) the head noun is marked with compound marker. The embedded predicate in (25c) bears third person agreement markers while in (25d) the embedded predicate bears second person agreement markers.

According to the second representation, which represents Dialect B, when the Genitive DP is co-indexed with the embedded predicate, the Genitive DP is the subject in the embedded clause as in (26a-b). These structures exemplify Nom/Gen case alternation.

Dialect B

- (26) a. [hiçkimse-nin_i/hiçkimse_i iflas et-me-miş-tir_i] haber-in_j
 nobody-GEN/nobody-NOM bankruptcy get-NEG-PAST-MOD news-2SGPoss
 ‘your news that ‘nobody went bankrupt’
- b. [sen-in_i/sen_i saatlerce koş-tu-n_i] iddia-s_j
 you-GEN/you-NOM for hours run-PAST-2SG claim-CM
 ‘the claim that you ran for hours.’
- c. *[sen-in_i/sen_i gizlice evlen-di_i] söylenti-s_j
 you-GEN secretly get married-PAST-3SG rumor-CM
 ‘the rumor that you got married secretly’

d.*[sen-in_i/sen_i dün gece bayıl-d_i] iddia-n_j
 you-GEN yesterday night faint-PAST-3SG claim-2SGPoss
 'the claim that you fainted last night'

As for the structures in (26c-d), these examples are ungrammatical with both Nom/Gen case marked subjects for independent reasons. In both (26c-d) the embedded predicate bears third person agreement markers and hence there is a person agreement mismatch between the embedded predicate and the subject. These structures are ungrammatical with both Nominative and Genitive case marked subjects.⁸

As for the other structures namely (25a-d) and (26a-b), we applied a grammaticality judgment test in order to determine whether the two possible representations are actually realized in Turkish. Section 2.4.1 is an illustration of this grammaticality judgment test.

2.4.1 Dialect A and B

The structures in the grammaticality judgment test have been judged by 12 native speakers of Turkish all of whom are non-linguists. The target structures in the test include NPIs (5 items), scrambling structures (2 items), a structure which shows subject-verb agreement (1 item) and control structures which are either predicted to be

⁸ Dialect B speakers may interpret the sentences in which there is a person agreement mismatch between the embedded predicate and the genitive nominal similar to Dialect A speakers namely with a co-indexed *pro* in the embedded clause. We leave the discussion of this issue for future studies which will provide further conclusive tests.

grammatical or ungrammatical (7 items). The grammaticality judgment test has been given in Appendix.

The informants have been divided into two groups and the same structures have been given in two different formats. The first set included CNPCs the complement clauses of which have been put in quotation marks in order to make sure that the genitive DP is perceived as the subject of the clause as exemplified below.

- (27) “Kitab-a hiçkimse-nin bak-ma-mış-tır” düşünce-sin-e
book-DAT anybody-GEN look-NEG-PAST-MOD opinion-CM-DAT
katıl-ıyor-um.
agree-PROG-1SG
‘I agree with the opinion that nobody would have looked at the book.’

In the second set the complement clauses of CNPCs have not been put in quotation marks as illustrated below.

- (28) Kitab-a hiçkimse-nin bak-ma-mış-tır düşünce-sin-e
book-DAT anybody-GEN look-NEG-PAST-MOD opinion-CM-DAT
katıl-ıyor-um.
agree-PROG-1SG
‘I agree with the opinion that nobody would have looked at the book.’

Each group of structures has been judged by 6 informants. The following subsections articulate the target structures in each part with the conclusions of the grammaticality judgment test.

2.4.1.1 Negative Polarity Items

NPIs in Turkish are licensed by overt negation and NPIs in affirmative sentences yield ungrammaticality as the grammaticality contrast given in (29a-b) illustrates.⁹

(29) a. Hiçkimse konferans-a gel-me-di.
 anybody-NOM conference-DAT come-NEG-PAST-3SG
 ‘Nobody came to the conference.’

b. *Hiçkimse konferans-a gel-di.
 anybody-NOM conference-DAT come-PAST-3SG

The intended reading is: ‘Nobody came to the conference.’

⁹ Turkish NPIs have been morphologically grouped in the following way.

- (i) the adverb *hiç* ‘ever’. ‘at all’,
- (ii) the words that begin with the morpheme *hiç* such as *kiçkimse* ‘anybody’, *hiçbirşey* ‘anything’, *hiçbir* N ‘any N’,
- (iii) the words that do not contain the morpheme *hiç* such as *kimse* ‘anybody’, *asla* ‘ever’, and *katiyyen* ‘in any way, *sakın* ‘ever’. (Keleşir, 2001)

Kelepir (2001) holds that NPIs must be within the immediate scope of negation in order to be licensed in Turkish.¹⁰ This is exemplified in (30-31) below.

- (30) a. *Herkes kimse-yi gör-me-di-Ø.
 everybody anybody-A see-neg-past-3sg
- b. Kimse herşey-den ye-me-di-Ø.
 anybody-nom everything-Ab eat-neg-past-3sg
 ‘Nobody ate from everything.’ (Kelepir 2001, 219)

(30a) is ungrammatical because in Turkish, the universal quantifier ‘*herkes*’ can only be interpreted within the scope of negation. Negation is at a node immediately c-commanding the NPI leaving the universal quantifier outside the scope. In (30b), negation is at a node immediately c-commanding NPI and the structure is grammatical as universal quantifier ‘*herşey*’ is also within the scope of negation.

- (31) a. Hasan bazı insan-lar-a hiçbir resm-i göster-me-di-Ø.
 Hasan some person-pl-D any picture-A show-neg-past-3sg
 ‘Hasan didn’t show any pictures to some people.’

¹⁰ NPIs are also licensed in yes/no questions as in (1).

(1) Bura-ya gel-diğ-in-i hiçkimse gör-dü mü?
 here-DAT come-DIK-AGR_{NOM}-ACC anybody-NOM see-PAST question marker
 ‘Did anybody see you coming here?’

b. * Hasan hiçbir resm-i bazı insan-lar-a göster-me-di-Ø.
 Hasan any picture-A some person-pl-D show-neg-past-3sg

Intended reading: ‘Hasan didn’t show any pictures to some people.’

(Keleşir 2001, 230)

In Turkish, the indefinite ‘*bazı*’ cannot be interpreted within the scope of negation. In (31a) negation is at a node immediately c-commanding the NPI and the structure is grammatical as the indefinite ‘*bazı*’ is outside the scope of Negation. The ungrammaticality of (31b) is predicted as negation, immediately c-commanding and licensing NPI, takes the indefinite under its scope.

NPIs are a conclusive test in determining the position of the Genitive DP in CNPCs. If Genitive DP is the subject of the complement clause it must be licensed by negation in this domain. This requirement is illustrated in the following example for nominative subjects.

(32) Konferans-a hiçkimse hazırlan-ma-mış-tı
 conference-DAT anybody-NOM be prepared-NEG-InferentialPAST-PAST-3SG

iddia-sı-na inan-dı-m.
 claim-CM-DAT believe-PAST-1SG

‘I believed in the claim that nobody had been prepared for the conference.’

Negation immediately c-commands the NPI subject and takes it under its scope. If Genitive nominal is in the DP domain ungrammaticality is predicted as NPI is not immediately c-commanded by negation.

In the target structures given in (34a-e), negation is on the embedded predicate and negation on the main predicate is avoided because for some speakers NPIs in the embedded clause can be licensed by negation in the matrix clause as the following example suggest.

- (33) (?) Oğuz konferans-a hiçkimse gel-di
 Oğuz-NOM conference-DAT anybody-NOM come-PAST-3SG
 de-me-di.
 say-NEG-PAST-3SG
 ‘Oğuz didn’t say that anybody came to the conference.’

NPI cannot be licensed within the embedded clause as negation is not in the embedded clause. However NPI in the embedded clause is licensed by negation in the matrix clause in (33).

We have given the following target NPI structures in (34a-e). Note that NPIs can only be licensed within the embedded clause as negation in the matrix clause is avoided.

- (34) a. “Konferans-a hiçkimse-nin hazırlan-ma-mış-tı”
 conference-DAT anybody-GEN be prepared-NEG-InferentialPAST-PAST-3SG
 iddia-sın-a inan-dı-m.
 claim-CM-DAT believe-PAST-1SG
 ‘I believed in the claim that nobody had been prepared for the conference.’

b. “Kar-da hiçkimse-nin yürü-me-sin” fikr-i-ne katıl-ıyor-um.
snow-LOC anybody-GEN walk-NEG-IMP idea-CM-DAT agree-PROG-1SG

‘I agree with the idea that nobody should walk on the snow.’

c. “Kitab-a hiçkimse-nin bak-ma-mış-tır” düşünce-sin-e
book-DAT anybody-GEN look-NEG-PAST-MOD opinion-CM-DAT

katıl-ıyor-um.

agree-PROG-1SG

‘I agree with the opinion that nobody would have looked at the book.’

d. “Tatil-e hiçkimse-nin çık-ma-malı” emr-i
holiday-DAT anybody-GEN go-NEG-Necessitative command-CM

can-ımız-1 sık-tı.

life-1PLPoss-CM annoy-PAST

‘The command that nobody should go on a holiday annoyed us.’

e. Murat-ın “hiçkimse-nin okul-a git-me-meli”
Murat-GEN anybody-GEN school-DAT go-NEG-Necessitative

laf-1 çok şaşırtıcı.

statement-3SGPoss very astonishing

‘Murat’s statement that nobody should go to school is very astonishing.’

From the NPI structures illustrated in (34a-e), (34a), and (34e) have been found to be grammatical by 2 different informants from the second set with no quotation marks and (34c) has been found to be grammatical by 1 informant from the first set with quotation marks. Based on these judgments we have concluded that there are two

dialects in Turkish. Dialect A speakers who constitute the majority in the group do not interpret the Genitive DP as the subject in the embedded clause. In Dialect B, although marginal, Nom/Gen alternation is possible and genitive DP can be interpreted as the subject in the embedded clause.¹¹ Now we turn to other target structures.

2.4.1.2 Subject Verb Agreement

In Turkish root clauses and finite complement clauses, verbal agreement markers appear on the predicate that agree in person with the subject. When the subject is third person plural, then the embedded predicate can either bear singular or plural agreement markers. This is exemplified below in (35).

- (35) a. Arkadaş-lar-ımız topluca koş-muş-tur-Ø haber-i gel-di.
 friend-PL-1PLPoss altogether run-PAST-MOD-3SG news-CM come-PAST
- b. Arkadaş-lar-ımız topluca koş-muş-tur-lar haber-i gel-di.
 friend-PL-1PLPoss altogether run-PAST-MOD-3PL news-CM come-PAST
- ‘The news that our friends ran altogether came.’

The nominative case marked nominal is in its own clause and as (35a) indicates it is compatible with the embedded predicate which bears third person singular

¹¹ Dialect B speakers who interpret the Genitive DP as the subject in the complement clause do not find all the NPI structures to be grammatical. We leave the discussion of when the speakers use these marginal Genitive case marked subject constructions and when not for further research.

agreement markers. Now we turn to the target structure in the grammaticality judgment test with genitive subject illustrated below as (36).

- (36) “Arkadaş-lar-ımız-ın topluca koş-muş-tur” haber-i gel-di.
friend-PL-1PLPoss-GEN altogether run-PAST-MOD-3SG news-CM come-PAST
‘The news that our friends ran altogether came.’
*‘Our friends’ news that s/he ran altogether came.’

If the genitive DP is in [Spec TP], the embedded predicate can bear both singular and plural agreement markers as is the case with nominative subject in (35). If genitive DP in (36) is the genitive nominal in the DP domain, then there is a *pro* in [Spec TP] co-indexed with the predicate. However the structure with a singular *pro* co-indexed with the embedded predicate cannot be grammatical as the adverb ‘*topluca*’ which indicates the plurality of the subject is incompatible with *pro_{singular}* co-indexed with the embedded predicate.

If the structure is found to be grammatical, then the genitive DP which bears the plural marker is interpreted as the subject of the clause.

In the grammaticality judgment test 2 informants from the first set with quotation marks and 2 informants from the second set with no quotation marks have found the co-indexation example in (36) to be grammatical which indicates that the Genitive DP is perceived as the subject in the embedded clause by these speakers. The other informants have found the structure ungrammatical indicating that they do not interpret the Genitive

The scrambling example illustrated in (37a) has been found to be grammatical by 1 informant from both the first and second set. However scrambling has not been a conclusive test as the following control structure which is predicted to be ungrammatical because of person agreement mismatch has been found to be grammatical by one of the informants from the second set with no quotation marks.

- (38) *Kız-ım-a sen-in bağır-mış-ım iddia-sı
 daughter-1SGPoss-DAT you-GEN shout-PAST-1SG claim-CM
- ben-i üz-dü.
 I-ACC upset-PAST
- Intended reading: ‘Your claim that I shouted at my daughter upset me.’

As the structure is found to be grammatical with the intended reading, this indicates scrambling the constituent to the DP domain is possible for some speakers which decreases the validity of the scrambling test.

Based on NPI structures presented in section 2.4.1.1 and the structures which show subject-verb agreement given in section 2.4.1.2, we have concluded that the following structures have two different representations in Dialect A and Dialect B. The tree structures of the examples in (39) are given in (40).

(39) *Dialect A*

- a. sen-in_i [*pro**_{i/j} iflas et-miş-sin_j] haber-in_i
you-GEN bankruptcy get-PAST-2SG news-2SGPoss
'your news that 'you went bankrupt'
* 'your news that you went bankrupt'

Dialect B

- b. [kitab-a hiçkimse-nin_i bak-ma-mış-tır_i] düşünce-n_j
book-DAT anybody-GEN look-NEG-PAST-MOD idea-2SGPoss
'your idea that 'nobody would have looked at the book'
- c. [konferans-a hiçkimse-nin_i hazırlan-ma-mış-tı_i]
conference-DAT anybody-GEN be prepared-NEG-Infer.PAST-PAST-3SG
iddia-sı
claim-CM
'the claim that nobody had been prepared for the conference'

(40a) *Dialect A*

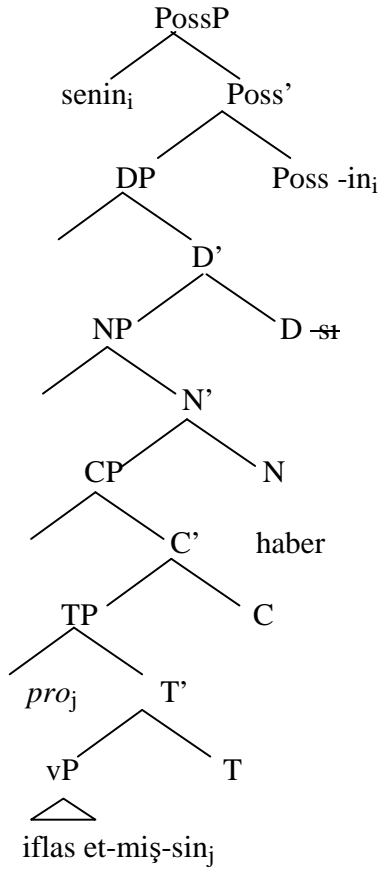

(40b) *Dialect B*

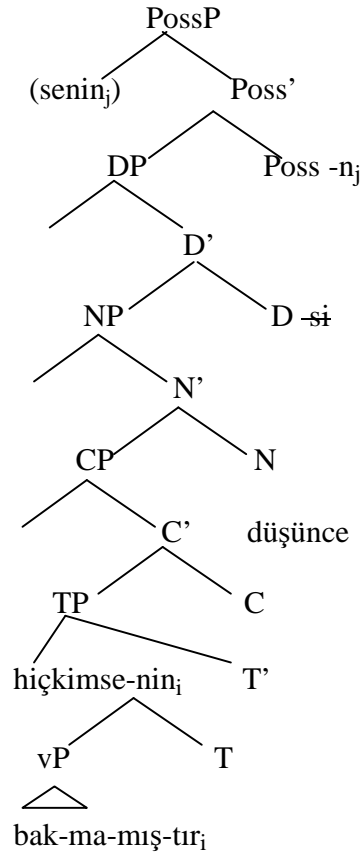

The tree structure in (40a) represents Dialect A which interpret the Genitive DP not as the subject in the embedded clause but as the nominal in the DP domain. (40b) represents Dialect B which takes the Genitive DP as the subject in the embedded clause in certain CNPCs.

The structure in (39c) which is found to be grammatical for Dialect B speakers is given below in (41) with the tree structure.

(41) [konferans-a hiçkimse-nin_i
 hazırlan-ma-mış-tı_i] iddia-sı_j

Dialect B

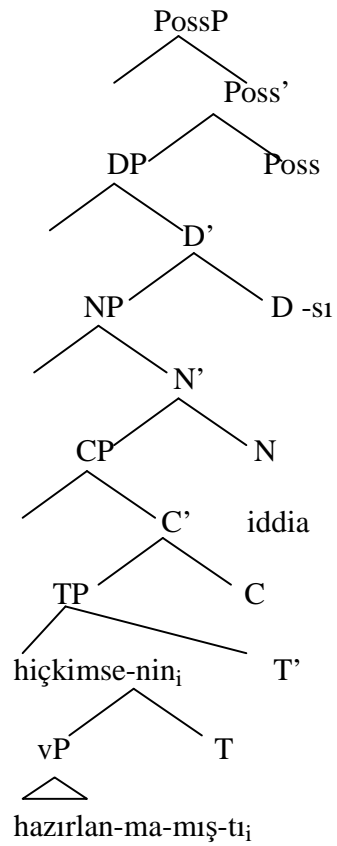

Nominative and genitive case licensing conditions in the CNPCs in (39b) and (40) will be discussed in detail in the fourth chapter.

The next section discusses the structural properties of NP-Gen NP-CM constructions in contrast to genitive-possessive constructions.

2.5 NP-GEN NP-POSS and NP-GEN NP-CM Constructions

As discussed in section 2.4, the structures in (42a-b) are higher order compounds in Dialect A and the relevant tree structure is given in (40a). The structures in (42c-d) are similar to (42a-b) in that there is a Genitive case marked DP however the head noun bears the compound marker *-(s)I* instead of possessive agreement markers.

Dialect A

- (42) a. *sen-in_i [pro*_{i/j} dün gece bayıl-d_{1j}] iddia-n_i*
 you-GEN yesterday night faint-PAST-3SG claim-2SGPoss
 ‘your claim that s/he fainted last night’
 *‘your claim that you fainted last night’

- b. *sen-in_i [pro*_{i/j} iflas et-miş-sin_j] haber-in_i*
 you-GEN bankruptcy get-PAST-2SG news-2SGPoss
 ‘your news that ‘you went bankrupt’
 * ‘your news that you went bankrupt’

- c. *sen-in_i [pro_{i/j} gizlice evlen-di_{i/j}] söylen-ti-si*
 you-GEN secretly get married-PAST-3SG rumor-CM
 ‘the rumor (about you) that you got married secretly’
 ‘your rumor that s/he got married secretly’

d. sen-in_i [*pro*_{i/j} saatlerce koş-tu-n_{i/j}] iddia-sı
 you-GEN for hours run-PAST-2SG claim-CM
 ‘the claim (about you) that you ran for hours.’
 ‘your claim that ‘you ran for hours’

Note that these CNPCs are similar in structure to simple NP-GEN NP-CM constructions discussed in section 2.2.2.

(43) a. ben-im yarış at-ı
 I-GEN race horse-CM
 ‘my race horse’

b. sen-in_i [*pro*_{i/j} saatlerce koş-tu-n_{i/j}] iddia-sı
 you-GEN for hours run-PAST-2SG claim-CM
 ‘the claim (about you) that you ran for hours.’
 ‘your claim that ‘you ran for hours’

The DP nominal bears genitive case but the head noun is marked with the compound marker in both (43a-b). As is the case with simple NP-GEN NP-CM constructions given in (43a), there is not necessarily a thematic relation between the genitive nominal and the head noun in these CNPCs as well. It is possible to interpret these constructions in the following way.

(44) a. ben-im bahset-tiğ-im yarış at-ı
 I-GEN mention-NOM-AGR_{NOM} race horse-CM
 ‘the race horse that I mentioned about’

b. senin ile ilgili/ileri sür-düğ-ün [*pro*_{i/j} saatlerce koş-tu-n *i/j*]
 you-GEN with about/forth put-NOM-AGR_{NOM} for hours run-PAST-2SG
 iddia-sı
 claim-CM
 ‘the claim (about you/you put forth) that you ran for hours.’

This analysis for NP-GEN NP-CM constructions is further supported by co-indexation differences between genitive-possessive constructions and NP-GEN NP-CM constructions.

Note that the co-indexation possibilities are not the same in (42a-b) and (42c-d). The Genitive DP cannot be co-indexed with the *pro* in the embedded clause when the head noun bears possessive agreement markers while co-indexation is possible when the head noun bears the compound marker -(s)I. Assuming the tree structure in (19b) proposed for simple NP-GEN NP-CM constructions explains co-indexation differences between (42a-b) and (42c-d).

As illustrated in the tree structures below in (42a-b), genitive case marked DPs do not surface in the same position.

Dialect A

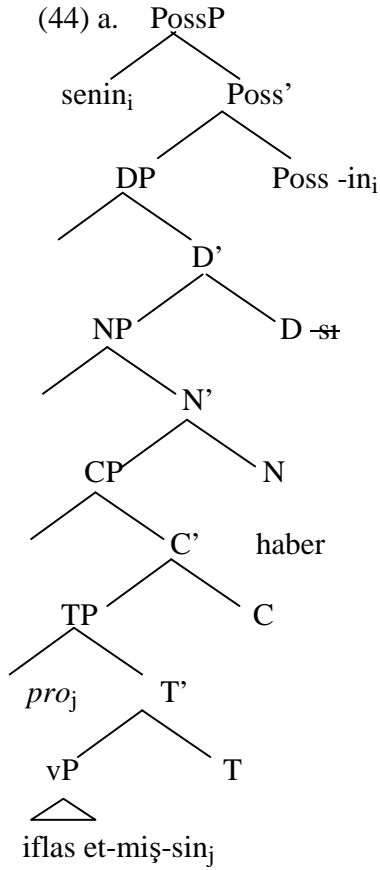

Dialect A

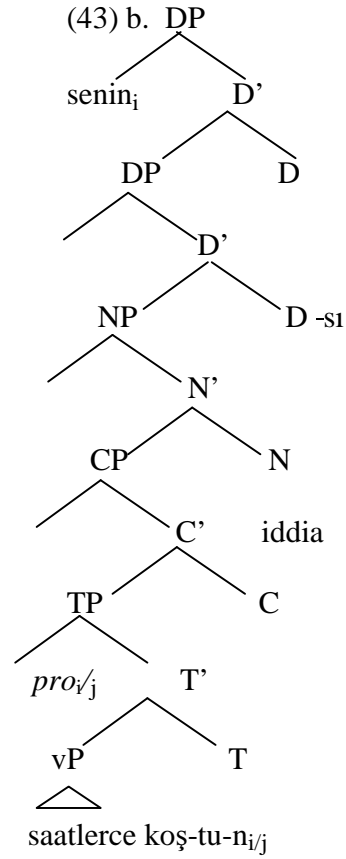

While genitive nominal is in the specifier position of the PossP in (45a), it is in the higher DP projection within an elliptical clause in (45b) and hence *pro* is in the binding domain of the genitive DP in (45a) while it is not in (45b).

This analysis is also in line with Öztürk (2001) who suggests that agreeing and non-agreeing genitive phrases have different structures in that the genitive nominal in non-agreeing genitive phrases are determiners while genitive nominals in genitive-possessive constructions are possessors.

2.6 Summary

This chapter has discussed the structural properties of CNPCs which are parallel in structure to simple compounds in Turkish. For Dialect A speakers genitive case marked nominals are either the genitive possessors or part of an elliptical clause. If the head noun bears possessive agreement markers which agree in person with the genitive nominal, the genitive nominal is the genitive possessor occupying [Spec DP]. If the head noun bears compound marker then the genitive nominal is part of the elliptical clause. We base our arguments on the fact that genitive constructions and NP-GEN NP-CM constructions show some contrasting properties and differ with respect to co-indexation properties.

The speakers of Dialect B which is restricted to some CNPCs and/or speakers on the other hand interpret the genitive case marked nominal as the subject in the embedded clause when co-indexation of the genitive nominal with the agreement markers on the embedded predicate is possible. Chapter four focuses on the case checking mechanism in CNPCs.

CHAPTER THREE

CASE LICENSING IN TURKISH

This chapter focuses on Nominative/Genitive subject case licensing in Turkish. The fact that in relative clauses and complement clauses, the subject is marked with Genitive case marker is observed in many languages. The following presents examples from relative clause constructions in Japanese (Hiraiwa, 2005), Dagur (Hale 2002, Sells 2008), Cuzco Quechua (Lefebvre and Muysken, 1988) and Turkish (Kornfilt 2003) respectively.

Japanese

- (1) a. [Kinoo John-ga kat-ta hon]-wa omosiro-i.
Yesterday John-Nom buy-Pst.Adn book-Top interesting-Prs.
'The book which John bought yesterday is interesting.'
- b. [Kinoo John-no kat-ta hon]-wa omosiro-i.
Yesterday John-Gen buy-Pst.Adn book-Top interesting-Prs.
'The book which John bought yesterday is interesting.'

(Hiraiwa, 2005)

Dagur

- (2) a. [mini au -sen] mery -miny sain.
[1sGen buy-PERF] horse-1sGen good
'The horse I bought is good.' (Hale 2002: 109)
- b. [Si namde uk-sen] biteg-Siny
[you.NOM I.DAT give-PART] book-2sg.poss
'The book you gave to me' (Sells, 2008)

Cuzco Quechua

- (3) a. [Runa-Ø qulqi-ta qu-sqa-n] warmi-man chay-ta ni-pa-ni.
man-Nom money-Acc give-Nml-3 woman-to that-Acc say-Pst-1
'I said that to the woman to whom the man gave the money.'
- b. [Xwancha-q runa-/*ta riku-sqa-n] wasi-ta rura-n.
Juan-Gen man-OBJ/Acc see-Nml-3 house-Acc build-3
'The man that Juan saw builds a house.'

(Lefebvre and Muysken, 1988)

Turkish

- (4) Ali-nin geçen gün dükkan-dan al-dıĝ-ı bu şahane vazo.
Ali-GEN past day shop-ABL buy-FN-3SG this magnificent vase
'this magnificent vase which Ali bought at the store the other day'

(Kornfilt, 2003)

In Japanese, the case marker on the subject optionally alternates between nominative and genitive in relative clauses as the examples (1a-b) illustrate and in nominal complements as shown in (5) below. This syntactic phenomenon has been discussed under the term Ga (Nominative)/No (Genitive) conversion. (Miyagawa 1993, Hiraiwa 2005)

- (5) a. John-wa [CP kinoo Mary-ga ki-ta koto/no]-wo sira-nakat-ta.
John-Top yesterday Mary-Nom come-Pst.Adn FN/C-Acc know-Neg-Pst
'John didn't know that Mary came yesterday.'
- b. John-wa [CP kinoo Mary-no ki-ta koto/no]-wo sira-nakat-ta.
John-Top yesterday Mary-Nom come-Pst.Adn FN/C-Acc know-Neg-Pst
'John didn't know that Mary came yesterday.'

(Hiraiwa, 2005)

In Turkish, genitive subject case marking is observed in complement clauses, in certain adjunct clauses, relative clauses, and nominal complements. However Genitive/Nominative case alternation is not fully optional in that in these clauses nominative case marking does not freely alternate with genitive case marking as noted by Kennelly (1992, 1996), Kural (1993), Aygen (2002), Kornfilt (2003), Ulutaş (2008).

This chapter first takes a look at subordinate clauses and the distribution of Nominative, Genitive and Accusative subjects in Turkish. The second section presents an overview of the former accounts on Turkish Nom/Gen subject case licensing within the generative framework.

3.1 Some Properties of Nominative, Genitive and Accusative Subjects in Turkish

In Turkish root clauses, only nominative subject case marking is licensed. This is illustrated in the ungrammaticality of the matrix clause with case markers other than nominative case in (6).

- (6) Ben- Ø /*i/im/a/de/den bugün okul-a git-ti-m.
 I-NOM/*ACC/*GEN/*DAT/*LOC/*ABL today school-DAT go-PAST-1SG
 ‘I went to school today.’

(7a-c) below illustrate that subjects of complement clauses can bear Nominative, Genitive or Accusative case.

- (7) a. Sen sinema-ya git-ti-n san-dı-m.
 you-NOM cinema-DAT go-PAST-2SG think-PAST-1PS
 ‘I thought that you went to the cinema.’
- b. Sen-in sinema-ya git-tiğ-in-i san-dı-m.
 you-GEN cinema-DAT go-DIK-AGR_{NOM}-ACC think-PAST-1SG
 ‘I thought that you went to the cinema.’
- c. Sen-i sinema-ya git-ti-n san-dı-m.
 you-ACC cinema-DAT go-PAST-2SG think-PAST-1SG
 ‘I thought that you went to the cinema.’

In adjunct clauses, however, only Nominative and Genitive case marking is licensed as in (8a-b).

- (8) a. Sen-(*in) Ayşe-yi gör-düğ-ün için mutlu-sun.
 you-NOM Ayşe-ACC see-DIK- AGR_{NOM} since happy-2SG
 ‘You are happy since you saw Ayşe.’
- b. Sen-in o iş-e gir-me-n için uğraş-tı-k.
 you-GEN that job-DAT start-mA-AGR_{NOM} for strive-PAST-1PL
 ‘We strived to make you start that job.’

The following sub-sections discuss the distribution of subject case marking in the subordinate clause types.

3.1.1 Complement Clauses

In Turkish, complement clauses can come in the forms of nominalized and verbal clauses where the distinction is based on the nature of the markers on the embedded predicate.

The canonical embedding strategy in Turkish is nominalization where the embedded verb is marked with one of -DİK/-(y)AcAK, -mA/k nominalizers. The embedded clause is marked with a case marker assigned by the matrix clause as illustrated in the following examples.

- (9) a. Sen-*(in) ev-e gel-diğ-in-i bil-mi-yor-du-m.
you-GEN house-DAT come-AGR_{NOM}-ACC know-NEG-PROG-PAST-1SG
'I didn't know that you came home.'
- b. Sen-*(in) bu şarkı-yı söyle-me-n-e bayıl-ıyor-um.
you-GEN this song-ACC sing-AGR_{NOM}-DAT like(adore)-PROG-1SG
'I like your singing/the way you sing this song.'
- c. Ben-*(im) bu şarkı-yı söyle-me-m-den hoşlan-ma-dı.
I-GEN this song-ACC sing-AGR_{NOM}-ABL like-NEG-PAST-3SG
'She didn't like my singing/the way I sang the song.'

In (9a) the embedded clause is marked with accusative case, in (9b) with dative case and in (9c) with ablative case marker.

The appearance of Genitive subject in embedded clauses correlates with the occurrence of the nominalizers –DIK/-(y)AcAK and –mA¹.

The agreement markers on the embedded verb are from the nominal agreement paradigm as illustrated in (10a-b).

(10) a. Ayşe-*(nin) dışarı-ya çık-tığ-ın-ı/çık-acak-ın-ı san-dı-m.
 Ayşe-GEN outside-DAT go out-AGR_{NOM}-ACC think-PAST-1SG
 ‘I thought Ayşe went/would go out.’

b. Ayşe-*(nin) dışarı-ya çık-ma-sın-ı iste-di-m.
 Ayşe-GEN outside-DAT go out-AGR_{NOM}-ACC want-PAST-1SG
 ‘I wanted Ayşe to go out.’

¹ Nominalizers in Turkish embedded clauses have been studied extensively and different classifications have been proposed. Underhill (1976) holds that –DIK/(y)AcAK and –mA are gerundives. Kornfilt (1984) proposes that –DIK/(y)AcAK are nominalizers. Kennelly (1990) and Aygen (2002) assume that –DIK/(y)AcAK are aspect morphemes. Kural (1994) analyzes –İş as gerundive and Kural (1994) and Göksel (1997) suggest that –DIK/(y)AcAK are tense morphemes with –k as the complementizer. Keleşir (2006) also assumes –DIK to be tense morpheme but diverges from Kural (1994) and Göksel (1997) in that she takes T head as a defective head with no tense value.

An additional nominalizer is –(y)İş. However as Kural (1993) notes –(y)İş behaves in a manner different from the other nominalizers. Underhill (1976) analyzes –(y)İş as a true nominalizer. Kural on the other hand notes that –(y)İş (i) can assign structural case, (ii) appear with causative, passive and negative morphemes and (iii) be modified by frequency adverbs indicating that –(y)İş has Infl level verbal properties as is the case with –DIK/-(y)AcAK, –mA/K. However –(y)İş behaves like a typical gerund when contrasted with infinitive marker –mAK and tense markers –DIK/-(y)AcAK.

(1) Ahmet-Ø [PRO Berna-yı öp-me-yi] hep unut-uyor-Ø
 A.-NOM B.ACC kiss-mEK-ACC always forget-PRES-AGR
 ‘Ahmet always forgets to kiss Berna.’

(2) Ahmet-Ø [pro Berna-yı öp-üş-ü]nü hep unut-uyor-Ø
 A.-NOM B.-ACC kiss-Is-AGR-ACC always forget-PRES-AGR
 ‘Ahmet always forgets kissing Berna.’

(3) Ahmet- Ø [pro Berna-yı öp-tüğ-ü]nü hep unut-uyor- Ø
 A.-NOM B.-ACC kiss-DIK-AGR-ACC always forget-PRES-AGR
 ‘Ahmet always forgets that he kissed Berna.’

(Kural, 1993)

In (1) Ahmet has not performed the act of ‘kissing’ while in (2) he forgets a specific instance of ‘kissing’ that has occurred reflecting the difference between infinitives and gerunds. In (3) Ahmet forgets everything about the ‘kissing’ event while in (2) he may remember the event but may not remember the details of the event. Thus in this study there will be focus on only –DIK/-(y)AcAK, –mA.

- c. Ayşe-*(nin) makale-sin-i henüz oku-ma-dı-m.
 Ayşe-GEN article-3SGPoss-ACC yet read-NEG-PAST-1sg.
 ‘I have not read Ayşe’s article yet.’

Note that the structures in (10a-b) in which the subject is marked with genitive case and the embedded predicate bears nominal agreement markers are similar in structure to the noun phrase given in (10c). In the simple noun phrase given in (10c) the subject bears genitive case and possessive agreement markers appear on the head noun.

Nominalizers occur in the slot in which TAM markers typically appear on a predicate.

- (11) a. Ayşe-*(nin) geçen sene tatil-e git-tiğ-in-i duy-du-m.
 Ayşe-GEN last year holiday-DAT go-AGR_{NOM}-ACC hear-PAST-1SG
 ‘I heard that Ayşe went on a holiday last year.’

- b. Ayşe geçen sene tatil-e git-ti diye duy-du-m.
 Ayşe-NOM last year holiday-DAT go-PAST-3SG say hear-PAST-1SG
 ‘I heard that Ayşe went on a holiday last year.’

In (11a) the slot following the verb is occupied by nominalizer –DIK whereas in (11b) past tense marker appears in that slot.

Nominalizers –DIK/-(y)AcAK have an impoverished tense interpretation (cf. Underhill 1976, Erguvanlı-Taylan 1988) while –mA is fully dependent on the matrix clause for tense interpretation.²

As the examples (9-11) illustrate, Nom/Gen case alternation yields ungrammaticality in these complement clauses. However in certain complement clauses Nom/Gen alternation seems to be optional.

(12) a. Okul-a öğretmen gel-diğ-in-i bil-iyor-um.
 school-DAT teacher-NOM come-AGR_{NOM}-ACC know-PROG-1SG
 ‘I know that a teacher came to the school.’

b. Okul-a öğretmen-in gel-diğ-in-i bil-iyor-um.
 school-DAT teacher-GEN come-AGR_{NOM}-ACC know-PROG-1SG
 ‘I know that the teacher came to the school.’

² Underhill (1976) suggests that –DIK has non-future interpretation and (y)-AcAK future interpretation. However Taylan (1988) points out that –DIK/-(y)AcAK express modality based on adverbial tests.

–DIK can co-occur with past, present and future adverbials as the following examples indicate.

(1) Sen-in dün gel-diğ-in-i bil-iyor-um.
 you-gen yesterday come-DIK-3POSS-ACC I.know
 ‘I know that you came yesterday.’

(2) Hasan sen-in şimdi uyu-duğ-un-u düşün-ecek.
 Hasan you-gen now sleep-DIK-2POSS-ACC will.think
 ‘Hasan will think that you are sleeping now.’

(3) Sen-in yarın git-tiğ-in-e inan-a-mı-yor-um.
 you-gen tomorrow go-DIK-2POSS-DAT I.can’t.believe
 ‘I can’t believe you are going tomorrow.’

–(y)AcAK also expresses modality as it is possible to use it with a past adverbial.

(4) Hasan-in dün gel-eceğ-in-i bil-iyor-du-n.
 Hasan-gen yesterday come-AcAK-3POSS-ACC you.knew
 ‘You knew Hasan was going to come yesterday.’

(5) Engin-in dün televizyon-da konuş-acağ-in-ı ban-a söyle-me-di-ler.
 Engin-gen yesterday TV-loc talk-AcAK-3POSS-ACC I-dat tell-NEG-PAST-3PL
 ‘They didn’t tell me that Engin was speaking on TV yesterday.’

The optionality, however, is correlated with a different interpretation in each instance. In (12a) in which the subject bears Nominative case marker, note that it receives an indefinite/non-specific interpretation. In (12b) on the other hand the Genitive subject has specific/definite reading. Aygen (2002) points out that genitive case marks definiteness/specificity if it is not in a generic context.

- (13) Öğrenci-nin iste-diğ-i tembellik yap-mak-tır.
 student-GEN want-asp-agr laziness do-INF-Generic/Epistemic marker
 ‘It is laziness that any student/a student wants’= ‘What any/a student wants is laziness.’

(Aygen, 2002)

In (13) although the subject bears Genitive case marker specificity/definiteness reading is not available in this generic context.

Now we turn to verbal embedded clauses. Verbal embedded clauses are those that are identical to matrix clauses in that they allow nominative subject and the full array of tense, aspect, mood (TAM) markers. Subject agreement markers on the embedded predicate are from the verbal agreement paradigm as in (14).

- (14) Sen okul-da-ki toplantı-ya gid-ecek/miş/iyor/ ti-n
 you-NOM school-LOC- REL meeting- DAT go-FUT/PAST/PROG/PAST-2SG

sandım.

think-PAST-1SG

‘I thought that you will go/went/are going/went to the meeting at the school.’

With a certain set of matrix verbs, the complement clauses can be in the form of a verbal clause which is formally similar to ECM clauses. These matrix verbs are *san* ‘believe’, *bil* ‘know’, and *zannet* ‘think’ which form a semantically well defined class (Moore 1998). As is the case with nominative subject verbal clauses, ECM clauses allow full array of TAM markers on their verbal predicate and the agreement marker is chosen from the verbal agreement paradigm.

(15) Sen-i okul-da-ki toplantı-ya git-ti-(n)/gid-ecek-(sin)/gid-iyor-(sun)
 you-ACC school-LOC-REL meeting- DAT go- PAST / go-FUT /go- PROG -2SG

san-dı-m.

think-PAST-1SG

‘I thought that you went / will go / are going to the meeting at the school.’

As the contrast between (14) and (15) illustrates verbal agreement marker on the embedded predicate is obligatory in verbal clauses with nominative subject whereas it is optional in ECM clauses.³(Kornfilt 1976, Eroğlu 1997, Özsoy 2001)

3.1.2 Adjunct Clauses

The nominalizers –DIK/-(y)AcAK and –mA can also appear on the verbs of adjunct clauses. Similar to complement clauses, adjunct clauses with nominalizers have overt

³ There are three dialects reported for ECM constructions in Turkish. For some speakers agreement marker on the embedded predicate is obligatory (Pullum 1975), for some others agreement marker is not obligatory (Kornfilt 1976) and for some other speakers agreement marker on the embedded predicate is optional (Kural 1993, Eroğlu 1997, Moore 1998, Aygen 2000, Özsoy 2001)

agreement markers on the embedded predicate. –DIK/-(y)AcAK adjunct clauses license nominative subjects while –mA clauses license genitive subjects.

(16) a. Ben (*-im) alışveriş yap-tığ-ım için yorul-du-m.
 I-NOM shopping do-AGR_{NOM} since get tired- PAST-1SG
 ‘I got tired as I did shopping.’

b. Ayşe-*(nin) Ankara-ya git-me-si için bilet al-dı-k.
 Ayşe-GEN Ankara-DAT go-AGR_{NOM} for ticket-NOM buy-PAST-1PL
 ‘We bought a ticket for Ayşe to go to Ankara.’

Aygen (2002) notes that in certain adjunct –DIK/-(y)AcAK clauses Nom/Gen case alternation is possible as the following examples indicate.

(17) a. Hasan-ın duy-duğ-un-a göre herkes duy-acak-mış.
 Hasan-GEN hear-DIK-AGR_{NOM}-DAT according to everybody hear-FUT-REP
 ‘According to what Hasan heard, everybody will hear (it)’

b. Hasan duy-duğ-un-a göre herkes duy-acak.
 Hasan-NOM hear-DIK- AGR_{NOM}-DAT since everybody hear-FUT
 ‘Given that/since Hasan heard, everybody will hear (it)’

(Aygen 2002, 17-18)

However Nom/Gen case alternation yields different interpretations. Aygen attributes the difference between (17a) and (17b) to properties of ‘göre’. Aygen holds that in (17a) ‘göre’ is a postpositional phrase whereas it is a complementizer in (17b).

Another type of adjunct clauses are gerundive (Lewis 1967) or adverbial (Kornfilt 2002) adjunct clauses without nominalizers which license only nominative subject.

(18) a. (Sen) araba kullan-ır-ken çok dikkatsiz
you-NOM car drive-AORIST-GER very careless

ol-abil-iyor-sun.

be-PROBABILITY-PROG-2SG

‘You can be very careless while driving a car.’

b. Oğuz tüm yemeğ-i yi-yince biz aç kal-dı-k.
Oğuz-NOM whole meal-ACC eat-GER we hungry remain-PAST-1PL

‘When Oğuz ate the whole meal, we remained hungry.’

These adjunct clauses do not show any overt agreement morphology on their verbs as can be observed in (18a-b).

The other constructions in which GEN/NOM alternation is observed in Turkish are relative clause and complex noun phrase constructions. In section 3.1.3 we will look at relative clauses and in section 3.1.4 at CNPCs.

3.1.3 Relative Clauses

A typical Turkish relative clause construction is one in which the embedded verb is marked with one of the two relativizers: -(y)An and –DIK (Underhill 1972, Hankamer and Knecht 1976, Barker 1990, Özsoy 1994, Haig 1997, Kornfilt 2000, 2006, Çağrı 2005, Öztürk 2007).⁴

⁴ Other than -(y)An and –DIK, Turkish has –mİş, -(y)AcAK and –Ar participles which can be in the form of a relative clause (Özünü 1984). However as it may be observed below they form a unit like compounds. Thus in this study we will focus on typical relative clauses formed with –DIK and -(y)An relativizers in Turkish.

-Mİş

- (1) ben-im haşla-n-mış yumurta-m
I-GEN boil-PASS-mİş egg-POSS
'my boiled egg'
*Haşlanmış benim yumurtam'

-AcAK

- (2) İstanbul-un gör-ül-ecek yer-ler-i
İstanbul-GEN See-PASS-(y)AcAK place-PL
'the places to be seen in Istanbul'
*Görülecek İstanbul'un yerleri'

-Ar

- (3) yeni çal-ar saat
new Ring-Ar clock
'the new alarm clock'
*çalar yeni saat'

- (4) beğen-diğ-im aç-ıl-ır kapa-n-ır masa
Like-DIK-AGR_{NOM} Open-PASS-Ir close-PASS-Ir table
'the drop leaf table that I liked'
*açılır kapanır beğendiğim masa'

–(y)An is generally referred to as the subject relative form which is used for relativization of the subject ⁵(Underhill, 1972).

(19) [Dün Ø_i bahçe-de oyna-yan] çocuk_i (*un) bugün gör-ün-mü-yor.
yesterday garden-LOC play-(y)An child-NOM today appear-NEG-PROG

‘The child that played in the garden yesterday does not appear today.’

In (19) there is an internal gap position within the relative clause which is co-indexed with the relativized nominal head ‘*çocuk*’. The grammatical function of the empty category is subject. As can be noted the verb does not bear any agreement morphology.

–DIK is referred to as non- subject relative (NSR) clause form which is used for relativization of the non-subject arguments (Underhill, 1972).

⁵ SR form –(y)An is grammatical in some structures in which the grammatical function of the head noun is non-subject.

- (1) a. [gemi yanaş-an] liman
Ship sidle-SR harbor
‘the harbor that a ship is sidling up to’
b. liman-a gemi yanaş-ıyor
harbor-DAT ship sidle-pres.prog.-3sg
‘a ship is sidling up to the harbor.’
c. [Gemi-nin yanaş-tığ-ı] liman
Ship-GEN sidle-NSR harbor
‘the harbor that the ship is sidling up to’

(Çağrı, 2005)

Çağrı (2005) notes that –(y)An form yields non-specific interpretation of the subject ‘gemi’ as in (1a) whereas –DIK form yields specific interpretation of the subject as in (1c).

- (20) [Dün ben-*(im) Ø_i bahçe-de gör-düğ-üm] çocuk_i bugün
 yesterday I-GEN garden-LOC see-DIK-1SG child-NOM today
 görün-mü- yor.
 appear-NEG-PROG
 “The child that I saw yesterday in the garden does not appear today.”

In (20) the internal gap position within the relative clause is co-indexed with the relativized nominal head ‘*çocuk*’ and its grammatical function is object. Note that the verb bears nominal agreement morphology and the subject has genitive case.

Barker, Hankamer, Moore (1990) observe that there are structures in which the choice between either relative form does not make a difference in interpretation.

- (21) a. [[Ø_i kız-ı] kitab-ı getir-en] adam_i
 Ø girl-POSS-3s book-ACC bring-SR man
 ‘the man whose daughter brought the book’
- b. [[Ø_i kız-ının] kitab-ı getir-diğ-i] adam_i
 Ø girl-POSS-3s-GEN book-ACC bring-NSR-3s man
 ‘the man whose daughter brought the book’ (Barker et al., 1990)

(21a) is expected as the grammatical function of the empty category within the relative clause is part of the subject however (21b) is not expected.

For the –DIK relative clause form, both Çağrı (2005) and Öztürk (2007) assume that the genitive subject raises from [Spec VP] to [Spec TP]. Both Çağrı (2005) and

Öztürk (2007) argue that genitive subject remains in [Spec TP] and non-subject moves to [Spec CP] as the external nominal head. The example in (21) is in this sense not an exception to the assumptions of Çağrı (2005) and Öztürk (2007) as what raises to the nominalized head position is the possessor occupying the specifier position not the head of DP.

3.1.4 Complex Noun Phrase Constructions

As illustrated in detail in chapter two, in CNPCs both Nominative and Genitive subjects are licensed in different dialects. (22a-b) illustrate constructions in which the genitive marker on the subject cannot alternate with nominative case marker.

(22) a. Ayşe-*(nin) iş-ten çık-ma-(sı) ihtimal-i ben-i korkut-uyor.
 Ayşe-GEN job-ABL leave-AGR possibility-AGR I-ACC scare-PROG
 ‘The possibility that Ayşe will leave her job makes me afraid.’

b. Ayşe-*(nin) iş-ten çık-tığ-ı dedikodu-su ben-i rahat-sız ed-iyor.
 Ayşe-GEN job-ABL leave-AGR_{NOM} rumor-CM I-ACC anxious make-PROG
 ‘The rumor that Ayşe has left her job makes me anxious.’

As presented in chapter two, for Dialect B speakers although marginal and restricted to some specific CNPCs and/or speakers, Gen/Nom alternation is possible as illustrated in (23a-b) below.

(23) a. Konferans-a hiçkimse hazırlan-ma-mış-tı
conference-DAT anybody-NOM be prepared-NEG-InferentialPAST-PAST-3SG

iddia-sı-na inan-dı-m.
claim-CM-DAT believe-PAST-1SG

‘I believed in the claim that nobody had been prepared for the conference.’

b. Konferans-a hiçkimse-nin hazırlan-ma-mış-tı
conference-DAT anybody-GEN be prepared-NEG-InferentialPAST-PAST-3SG

iddia-sın-a inan-dı-m.
claim-CM-DAT believe-PAST-1SG

‘I believed in the claim that nobody had been prepared for the conference.’

Based on the distribution of Gen/Nom case subjects the following questions have been raised in the Turkish linguistics literature (Kennelly 1992, 1996, Kural 1993, Aygen 2002, 2007, Kornfilt 2003, 2007, Ulutaş 2008).

- (i) How can the distribution of Nom/Gen Case be accounted for in Turkish?
- (ii) Do Nominative/Genitive licensing constructions differ from each other?
- (iii) What is the syntactic mechanism that checks Nominative and Genitive case?

A number of analyses have been put forth in the Turkish literature as an answer to these questions. In the following sections a review of the existent analyses of case marking in Turkish will be presented.

3.2 Nom/Gen Subject Case in Turkish

Both within the GB framework and the MP⁶, different analyses have been put forth for subject positions in a variety of languages (Bobaljik and Diannes 1996, Shlonsky 2000,

⁶ Within the GB framework and the MP, the notion ‘subject’ has been defined based on the phrase structure and the syntactic properties attributed to it have been closely related to the syntactic configuration the subject is supposed to be. Within GB framework, case and theta assignment was done under government and these operations assumed DS and SS as interface levels as illustrated below (Chomsky 1981)

- (1) Mary ate the apple.
 [_S Mary INFL [_{VP} ate an apple]]

Theta role assignment makes the arguments visible for case assignment and INFL assigns the subject case and V assigns the object case under c-command.

When the bar levels were introduced to the phrase structure, the subject DP base generated in [Spec IP] could no longer get its theta role from VP as the following configuration in (2) illustrates. Then for theta role assignment of the external argument m-command was suggested (Chomsky 1986).

- (2) [_{IP} Mary [_I I [_{VP} [ate the apple]]]]

Case assignment is still done under c-command both for the subject and the object. While the subject gets its theta role under m-command, the object gets its theta role under c-command.

The dual nature of theta role assignment was handled under VP internal subject hypothesis (Zagona 1982, Sportiche 1988, Koopman and Sportiche 1991). According to this approach the external argument is base generated in [Spec VP] and moves to [Spec IP] for EPP and case purposes.

Pollock’s (1989) Split-Infl hypothesis decomposed IP into two functional projections as TP and AgrP. Taking these proposals a step further Chomsky (1991) came up with the functional projections AGRsP and AGRoP.

- (3) [_{AGRSP} Mary_i [_{AGRS} T_j Agrs [_{TP} t_j [_{AGROP} the apple_k [_{AGRO} V_m AgrO [_{VP} t_i [_V t_m t_k]]]]]]]]]]

Chomsky and Lasnik (1993) and Chomsky (1993) proposed that lexical items enter the derivation with their features already specified and they are checked by the relevant head. With this new configuration subject case is checked by T and AgrSP and the object case is checked by V and AgrOP. However this new phrase structure cannot explain how theta role assignment of the external argument is done as VP neither m-commands nor c-commands the subject NP.

Phrase structure was refined by Hale and Keyser (1993) and Chomsky (1995) under VP shell hypothesis which assumes a phonetically null verb ‘v’. The light verb ‘v’ assigns theta role to the external argument while V assigns theta role to the internal argument. The subject NP is base generated in [Spec vP] and then moves to [Spec TP] for case and EPP purposes.

Chomsky (2000) then came up with Agree mechanism which entails feature checking without overt movement. Under Agree the T head looks for a matching goal within its local domain, in this case the subject DP in [Spec vP], and values its own uninterpretable phi features with interpretable phi features of the subject DP and in turn values uninterpretable case feature of the goal. If the subject DP moves to [Spec TP] then it is EPP which attracts it to the [Spec TP].

As illustrated in detail in section 1.3, with the introduction of phases case checking mechanism also has been modified (Chomsky 2005). (See section 1.3 for a detailed analysis)

McCloskey 1996, Alexiadou and Anagnostopoulou 1998, Svenonius 2002, Hiraiwa 2005, Miyagawa 1993, 2008, 2009 among many others). These analyses can be grouped under two major groups: ‘Base Generation Analysis’ and ‘Movement Analysis’.

Base generation hypothesis assumes that the subject DP remains in the position it is externally merged. Within base generation analysis different functional projections have been proposed as external merge position. Öztürk (2005) assumes for Turkish a theta role introducing functional projection below TP which also checks case feature of the subject DP. Alexiadou and Anagnostopoulou (1998) on the other hand notes that TopicP is the external merge position for subjects in Spanish based on A’ properties of the subjects in Spanish.

Movement analysis on the other hand assumes internal merge/movement of the subject to another position from its externally merged position. Within ‘movement analysis’ different positions have been proposed for subjects with different case marking but what they all assume is the fact that the subject DP is above *v*P projection after movement (Bobaljik and Diannes 1996, Shlonsky 2000, McCloskey 1996, Svenonius 2002, Hiraiwa 2005, Miyagawa 1993, 2008, 2009).

In Turkish literature, different proposals on subject case licensing have been made for Nominative, Genitive, and Accusative subjects in favor of either ‘base-generation hypothesis’ or ‘movement hypothesis’.

In previous accounts some functional projections like CP (FinP), AgrP, TP, DP, or *n*P have been associated with subject case licensing. However the featural composition of these functional heads has been handled in different ways. Kennelly (1992, 1996) has argued that it is the Theta position of Infl that determines the nature of the case marker on the subject. Kural (1993), on the other hand, has claimed that it is

the nominal nature of C that is significant in subject case marking. Aygen (2002) has posited Mood, Modality and an external D head as Nominative and Genitive case licensers respectively. Kornfilt, (2003, 2007) holds that the verbal/nominal nature of Agr determines the case marker on the subject. Ulutaş (2008) has proposed that phi complete C and T with an independent tense interpretation plays a role in subject case licensing.

In the following section major analyses in Turkish literature with their core arguments will be presented.

3.2.1 Movement Analysis for Nominative Subjects

The movement analyses for the nominative subjects entail a target position above VP for subjects in Turkish (Kornfilt 2003, 2007, Aygen 2002, 2007, Ulutaş 2008), however the positions assumed for the nominative subject and the case checking mechanism differ in each study. The following sub-sections present the details of the main proposals made for nominative subjects.

3.2.1.1 Verbal Agr as Nominative Case Licenser

Kornfilt (2003, 2007) distinguishes between two types of Agreement in Turkish; verbal agreement and nominal agreement. George and Kornfilt (1981) claim that verbal Agr (FinP) licenses Nominative case while nominal Agr licenses Genitive case (Kornfilt 2003, 2007). Both Nominative and Genitive case is licensed in a finite, opaque domain and VP internal goal moves to [Spec AgrP] (FinP) to check its case.

Based on ECM constructions as exemplified below, George and Kornfilt (1981) and Kornfilt (2003) propose that it is Agr that licenses subject case in root and embedded clauses in Turkish and defines finiteness.

(24) a. Sen dün sabah ev-de yemek pişir-iyor-du-n
 you-NOM yesterday morning home-LOC food cook-PROG-PAST-2SG
 san-dı-m.
 believe-PAST-1SG
 ‘I believed (that) you were cooking food at home yesterday morning.’

b. Sen-i dün sabah ev-de yemek pişir-iyor-du
 you-ACC yesterday morning home-LOC food cook-PROG-PAST (no AGR)
 san-dı-m.
 believe-PAST-1SG
 ‘I believed you to have been cooking food at home yesterday morning.’

In (24a) there is TAM marker and verbal agreement markers on the embedded predicate. The subject bears Nominative case as expected. In (24b) on the other hand there is TAM marker but no agreement markers on the verb and the subject bears Accusative case. George and Kornfilt (1981) and Kornfilt (2003) conclude that Agr is the primary factor and Tense is only the secondary factor in licensing subject case and defining the finite domain.

The derivation of (24a) takes the following steps, (i) the subject DP which is base generated in VP internal position moves to [Spec AgrS] for case purposes, (ii) the structure is fully verbal and the agreement marker is from the verbal paradigm so Nominative case is licensed to the subject.

3.2.1.2 Mood and Epistemic Modality as Nominative Case Licenser

Aygen (2002) proposes that the mood feature on C and Epistemic modality feature on T together is nominative case licensing feature in Turkish. Based on the distribution of agreement morphology in different clauses, Aygen (2002) takes Agr as a manifestation of mood not as an independent functional head.

I	II	III	IV
[+indicative] [+conditional]	[optative]	[substantive]	[phrasal]
Biz gel-di-k We come-past-1p 'We came'	Biz gel-elim we come-1pl 'Let's come'	Biz iyi-yiz we fine-1pl 'We're fine'	Biz-im ev-imiz we-gen house-1pl 'Our house'
Biz gel-se-k We come-cond-1p 'If we come,.....'			[Biz-im gel-dig-imiz] we-gen come-asp-1p 'that we came'

Kornfilt (2003) takes verbal agreement markers in set III as Nominative case licenser and nominal agreement markers in set IV which is the same in form to possessive agreement markers as Genitive case licenser. However Aygen (2002) holds that while the first three sets mark the presence of mood, phrasal Agr and Agr in subordinate clauses given in set IV mark the absence of mood.

Aygen summarizes her analysis with the following chart.

		I	II	III	IV
Agreement	Person	Mood1	Mood2	Mood3-Substantive	-/øMood/Poss _s
Singular	1 st	-(I)m	-(e)yim	-(y)Im	-(I)m
	2 nd	n	(esin)	sIn	(sI)n
	3 rd	- Ø	-(e)	- Ø	-(s)I
Plural	1 st	k	-elim	-(y)Iz	-mIz
	2 nd	-nIz	-(es)in	-sInIz	-nIz
	3 rd	-lAr	-(e)lAr	-lAr	-lArI

The presence of Mood shown in sets I, II and III makes nominative case licensing possible. However Epistemic Modality as well as Mood is required to license nominative case.

Following Lyons (1977) Aygen takes modality as Tense and she assumes a specific kind of modality namely Epistemic Modality as Nominative case licenser in Turkish.

In contrast to Kornfilt (2003) who suggests Agr as primary and Tense as secondary Nominative case licenser, Aygen proposes that Agr is manifestation of Mood on C and Tense is Epistemic modality on T (FinP) and this complex feature licenses nominative case.

Aygen (2003) takes the contrast between Finite Complement Clauses and ECM clauses as a basis for this conclusion. Finite complement clauses appear with nominative subject and allow complex inflectional forms as in (25a) and Epistemic modality markers as in (25b).

(25) a. Ben-Ø [Kürşat-Ø gel - iyor-du /ecek-ti /miş-ti- Ø]
 I-Nom -Nom come- prog+perf/past /fut+perf/past /perf+past-3sg
 san-dı-m.
 think-perf/past-1sg
 ‘I thought that Kürşat was coming/was going to come/had come.’

b. Ben-Ø [Kürşat-Ø gel-ebilir-Ø] san-dı-m.
 I-Nom -Nom come-epistemic modality/ability think-perf/past-1sg
 ‘I considered Kürşat to be able to come.’

ECM clauses which appear with Accusative subject on the other hand allow Aspect/Tense and Deontic Modality morphemes as indicated in (26a). Epistemic Modality morphemes are not allowed in ECM clauses as the ungrammaticality of (26b) indicates.

(26) a. Ben-Ø [Kürşat-ı gel- di/ecek/iyor/miş/ir/meli/ebilir(D)] san-dı-m.
 I-Nom -acc come-asp/deontic modality think-perf/past-1sg
 I considered Kürşat to have come, to be coming, to have to (to be required to) come, to be able to come’

b. *Ben- Ø [Kürşat-ı gel-ebil- ir-di] san-dı-m.
 I-Nom -Acc come-able-aor- think-perf/past-1sg

If either mood or modality features is defective or absent then the structure is non-finite. The following representations are the tree structures of a finite and non-finite clause.

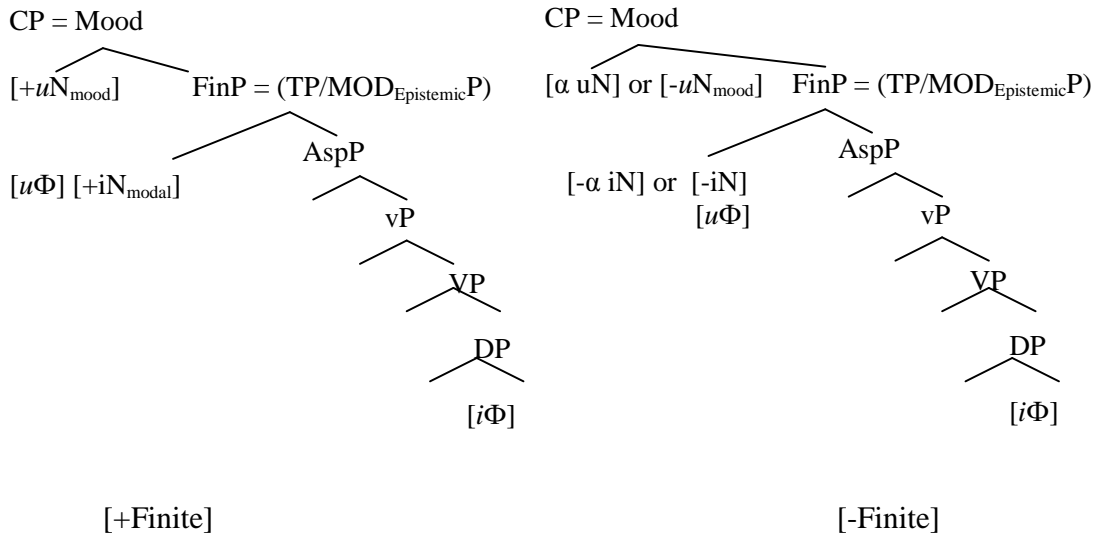

If the structure is non-finite in the sense that either Mood or Epistemic Modality is absent then either external *v* assigns accusative case to the subject yielding ECM constructions or phi features on an external D head assigns Genitive case to the subject.

3.2.1.3 Phi Complete C and T as Nominative Case Licenser

Ulutaş (2008) proposes that case licensing mechanism depend on two factors: phi-complete C (FinP) and T with an independent tense interpretation. Depending on the defective nature of C and/or T head the following subordinate clause types are given as possible combinations in Turkish.

$C^{\circ} = +/- \phi$ probe,
 $T^{\circ} = +/-$ Tense interpretation

- (a) ($C^{\circ} = + \phi$; $T^{\circ} = +$) Embedded Indicative Finite Clause (Nominative Case)
- (b) ($C^{\circ} = + \phi$; $T^{\circ} = -$) Embedded Subjunctive Finite Clause (Nominative Case)
- (c) ($C^{\circ} = - \phi$; $T^{\circ} = +$) Exceptional Case Marking (Accusative Case)
- (d) ($C^{\circ} = - \phi$; $T^{\circ} = -$) Nominalized Embedded Clauses

In the example (27), C (FinP) is phi complete and the T head has independent tense interpretation.

(27) Sen [dün biz okul-a git-me-di-k] zannet-ti-n.
you.NOM yesterday we-NOM school-DAT go-NEG-PST-1PL think-PST-2SG
'You thought that we didn't go to school yesterday.'

Through feature inheritance mechanism, FinP percolates phi features to T head and T head together with the C head probes for a matching goal. T head agrees with the subject DP in [Spec ν P]. The subject DP values uninterpretable phi features of the probe and in turn the probe values the case feature of the goal as nominative.

3.2.2 Base Generation Analysis

Base generation analysis assumes base generated position, which is typically assumed to be [Spec ν P], to be the only position for nominative subjects. However Öztürk (2005) suggests a radically different base generation position for Turkish nominative subjects as the following sub-section illustrate.

3.2.2.1 AgentP as Nominative Case Licenser

For a predicative NP to become an argument it should be checked for referentiality and case. Through referentiality a predicative argument becomes an NP argument and case assignment makes the same NP visible for theta role assignment.

Öztürk (2005) proposes that in Turkish the referentiality interpretation of an NP is done through the functional projection which introduces the theta role and they are

type shifted into arguments in these positions. The same functional category also checks the case feature of the NP so argument NP does not have to form an Agree relation with another functional head for case purposes.

According to this proposal the external argument is merged at [Spec AgentP] and the internal argument at [Spec ThemeP]. Their theta roles are assigned and they are checked for case and referentiality at this base generated position as indicated in the following representation. The structure assumed for the example in (28) is given in (29).

- (28) Çocuk kitab-ı oku-du.
 child book-ACC read-PAST
 ‘The child read the book.’

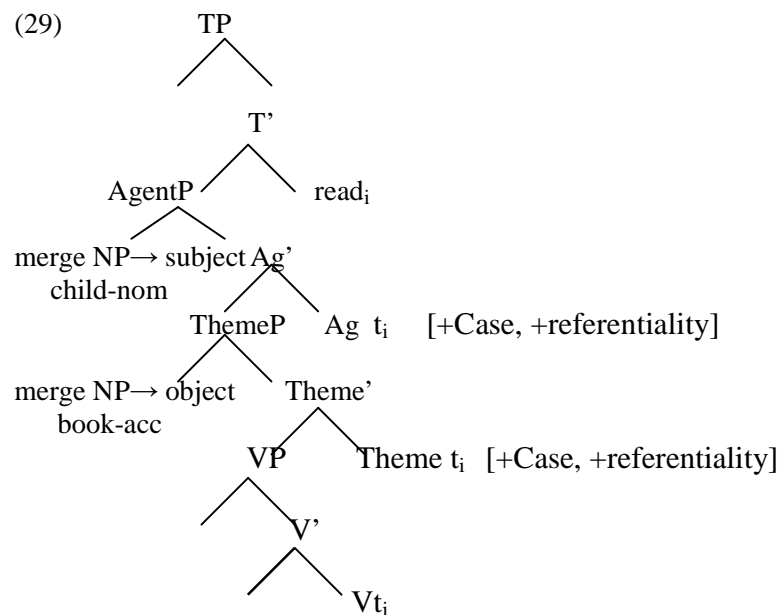

Öztürk (2005) further adds that the external argument does not check its case with TP through Agree so [Spec TP] is not always projected in Turkish. When it is projected it is for scope/discourse interpretive purposes. In line with Alexiadou and Anagnostopoulou

(1998), Öztürk suggests that EPP feature of TP is satisfied through head movement of V to T. Among the reasons Öztürk (2008) gives for suggesting that [Spec TP] is not always projected is that in pseudo incorporation, impersonal passive, raising constructions and clauses with quantifier subjects [Spec TP] is not required.

a) Pseudo incorporation: agents which are pseudo incorporated to the predicate form a complex predicate and they do not act as syntactic subjects.

(30) a. Doktor hasta-sın-ı gör-dü.
 doctor patient-3PS-ACC see-PAST
 ‘The doctor examined his patient.’

b. [Hasta-sın-ı]_i doktor_i t_j gör-dü.
 patient-3PS-ACC doctor see-PAST
 ‘The doctor examined his patient patient_i underwent doctor_i-examination.’

c. Hasta-sın-ı*_{ij} doktor_i gör-dü.
 patient-3PS-ACC doctor see-PAST
 ‘His*_{ij} patient underwent doctor_i-examination.’

When the subject is specific as in (30a) even if the object scrambles to pre-subject position the subject can bind it (30b). However when the agent is pseudo incorporated as in (30c) binding is not possible. As the examples illustrate [Spec TP] is not required as the pseudo incorporated subject does not act as a syntactic subject.

b) Scope: quantified subjects can take wide scope over negation only in the presence of overt agreement markers otherwise they can take only narrow scope.

(31) a. [TP [NegP [VP bütün çocuk-lar o test-e gir-me-di]]]
all children that test-DAT take-NEG-PAST
'All children did not take that test.' (not>all)

b. [TP bütün çocuk-lar_i [NegP [VP t_i o test-e gir-me-di-ler]]]
all children that test-DAT take-NEG-PAST-3PL
'All children did not take that test.' (all>not) (not>all)

In (31b) the subject has moved to [Spec TP] as the presence of overt agreement markers illustrate. In (31a) on the other hand the subject remains in its base generated position and negation takes scope over the subject.

Following Rizzi and Shlonsky (2005), Öztürk (2007) takes [Spec TP] as a criterial position which is generated only for scope/discourse interpretive properties as in (31b) otherwise it is not projected.

c) Impersonal Passives: impersonal passives are allowed in Turkish.

(32) Gir-il-mez.
enter-PASS-NEG-AORIST
'One cannot enter.'

In (32) there is not an overt subject or an expletive so [Spec TP] is not projected.

d) Raising: in raising construction the movement of the embedded subject to the matrix [Spec TP] is not obligatory.

(33) a. [_{TP}-----ban-a [(sen) yarışma-yı kazan-acak-*sin*] gibi gel-iyor]
to me you competition-ACC win-FUT-2PS like come-PROG
'It seems to me that you will win the competition.'

b. [_{TP} (Sen)_i ban-a [t_i yarışma-yı kazan-acak-(*sin*)] gibi gel-iyor-sun]
you to me competition-ACC win-FUT like come-PROG-2PS
'It seems to me that you will win the competition.' (Uygun 2005)

As (33a) illustrates [Spec TP] does not have to be filled by a subject DP as its EPP feature can be satisfied by verb movement. When the subject moves to [Spec TP] on the other hand overt agreement markers appear on the predicate as in (33b).

Based on these constructions Öztürk (2005) argues that T does not play a role in Case assignment and [Spec TP] is projected only for scope/interpretive properties. However T head plays a role in case realization in that it is required for the morphological realization of structural cases in a structure. V moves to each functional category which introduces the internal and external arguments on its way to T. When V complex head moves to T head, T takes all the functional projections under its scope and allows morphological case realization. In line with Harley (1995), Öztürk (2005) suggests the following Mechanical Case Parameter for Turkish.

The Mechanical Case Parameter

- a) If one case feature is checked structurally in a clause, it is realized as Nominative (mandatory case).
- b) If two case features are checked structurally in a clause the second is realized as Accusative.
- c) If three case features are checked structurally in a clause, the second is realized as Dative and the third as Accusative,
- d) The mandatory case in a multiple-case clause is assigned in the top/bottom AgrP.
(Harley, 1995)

3.2.3 Movement Analysis for Genitive Subjects

As opposed to nominative subjects for which both base generation and movement analysis have been proposed for genitive subjects in Turkish only movement analysis has been proposed (Kural, 1993, Kornfilt 2003, 2007, Aygen 2002, 2007, Ulutaş 2008, Miyagawa 2008, 2009). However the positions and the nature of the case licensing functional projections differ in each proposal as the following sub-sections demonstrate.

3.2.3.1 Nominal Agr as Genitive Case Licenser

Kornfilt (2003) argues that verbal Agr licenses Nominative case and nominal Agr licenses Genitive case. Miyagawa (2008, 2009) in line with Kornfilt suggests that the presence of the agreement markers on the embedded predicate in Turkish indicates CP projection since within the MP, C is the locus of phi features. Through feature inheritance mechanism phi features percolate from C to T head and genitive case is licensed.

However within the nominalized clauses with nominal Agr, Kornfilt (2003) makes a further distinction between nominalized –mA and –DIK/-(y)AcAK clauses.

(34) a. Sen-in ev-de yemek pişir-eceğ-in-i duy-du-m.
 you-GEN home-LOC food cook-FUTN-2SG-ACC hear-PAST-1SG
 ‘I heard that you will cook food at home.’

b. *Hasan-ın bu durmadan kumarhane-ye kaç-tık-lar-ın-ı
 Hasan-GEN this constantly casino-DAT escape-FN-PL-3SG-ACC
 duy-ma-mış-tı-m.
 hear-NEG-PERF-PAST-1SG

Intended reading: “I hadn’t heard (about) these constant runnings (away) of Hasan to the gambling casino.”

c. Yemeğ-i kim-in pişir-diğ-in-i sor-du-m/duy-du-m/
 food-ACC who-GEN cook-FN-3SG-ACC ask-PAST-1SG/hear-PAST-1SG/
 söyledim.
 tell-PAST-1SG
 ‘I asked/heard/told who had cooked the food.’

–DIK/-(y)AcAK clauses allow tense interpretation to some extent as in (34a).

Plural marker and determiner which are associated with nominal projections are not compatible with these clauses as illustrated in (34b) and finally WH-operator is licensed in these clauses which is an indicator of CP projection as in (34c).

(35) a. Sen-in ev-de yemek pişir-me-n-i
 you-GEN home-LOC food cook-NFN-2SG-ACC
 isti-yor-um/iste-di-m/iste-yeceğ-im.
 want-PRSPROG-1SG/want-PAST-1SG/want-FUT-1SG
 ‘I want/wanted/will want for you to cook food at home.’

b. (?) Hasan-in bu durmadan kumarhane-ye kaç-ma-lar-ın-dan
 Hasan-GEN this constantly casino-DAT escape-NFN-PL-3SG-ABL
 hoşlan-mı-yor-um.
 like-NEG-PERF-PAST-1SG

‘I don’t like these constant runnings (away) of Hasan to the gambling casino. (i.e. that Hasan should run to the casino constantly.

c. * Yemeğ-i kim-in pişir-me-sin-i söyle-di-m.
 food-ACC who-GEN cook-NFN-3SG-ACC tell-PAST-1SG
 Intended reading: “I said who should cook the food.”

-mA clause on the other hand is dependent on the matrix clause for tense interpretation as illustrated in (35a), it is compatible with plural marker and determiner as in (35b), and embedded Yes/No question formation is not possible with –mA clause indicating the absence of CP projection as in (35c).

Kornfilt (2003) concludes that these tests show structural difference of –DIK/-(y)AcAK and –mA clauses. While they are both nominalized clauses under a DP projection –DIK/-(y)AcAK clause has CP as verbal projection under DP projection but –mA clause is composed of fully nominal projections.

If agreement marker is from the nominal paradigm and the functional projections in the clause are fully nominal then Genitive case is licensed through categorial match as is the case in –mA clauses.

If the agreement marker is from the nominal paradigm but the functional projections are not fully nominal as is the case in –DIK/-(y)AcAK clauses then nominal Agr should be licensed to assign Genitive case. This is done through (i) categorial match

(whether the subordinate clause is fully nominal or not), (ii) referential indexing (whether the subordinate clause is an argument or not) or (iii) through predication (in relative clauses).

In (36a) below the –DIK clause has a CP projection and it is not fully nominal. As categorial match is not possible Genitive case is licensed on the subject through referential indexing. In (36b) as -mA clause is fully nominal without a verbal projection Genitive case is licensed through categorial match. In (36c), which is an example of an adjunct –DIK clause, Agr cannot assign case under categorial match as –DIK clause is not fully nominal or through referential indexing as it is an adjunct. Thus structural case, which is nominative in Turkish, is assigned to the subject.

(36a)

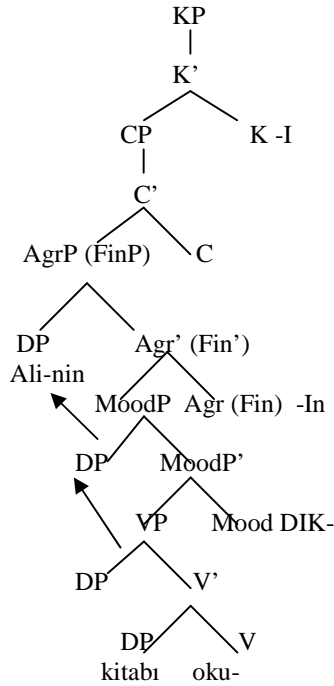

(36a) Ali-nin kitab-ı oku-duğ-un-u
 Ali-GEN book-ACC read-FN-3SG-ACC
 “That Ali read the book”
 (as a direct object)

(36b)

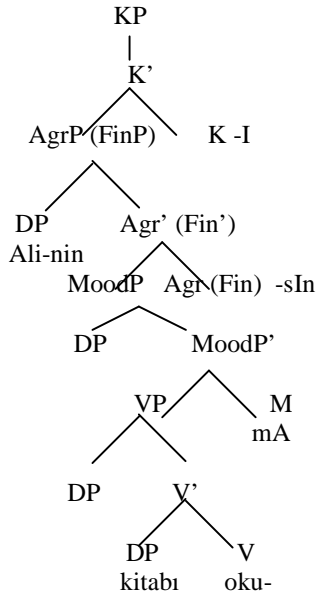

(36b) Ali-nin kitab-ı oku-ma-sın-ı
 Ali-GEN book-ACC read-NFN-3SG-ACC
 “For Ali to read the book”
 [= ‘for Ali’s reading the book’]

(36c)

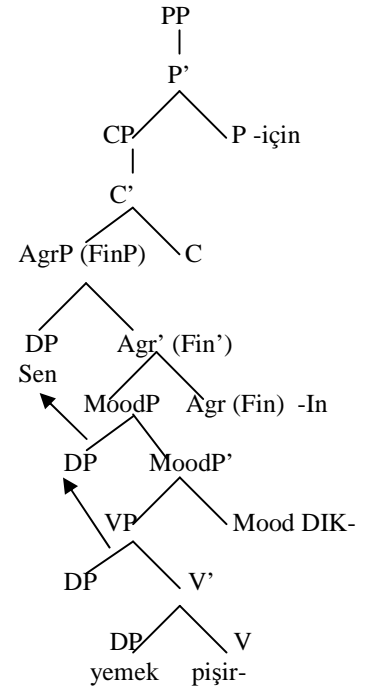

(36c) Sen yemek pişir-diğ-in için
 you-NOM food cook-FN-2SG
 because
 “because you cooked”

In the following examples, (37a) is an overtly headed Relative Clause, (37b-c) are free Relative Clauses and (37d) is a comparative construction. The embedded subjects are all marked with genitive case. For these structures genitive case licensing through categorial match is not possible as –DIK clause is not fully nominal. Referential indexing is not possible either, as these clauses are not argument clauses and Agr cannot receive a theta role from the matrix clause to assign genitive case.

(37) a. Ali-nin geçen gün dükkan-dan al-dıđ-ı bu şahane vazo.
Ali-GEN past day shop-ABL buy-FN-3SG this magnificent vase
'this magnificent vase which Ali bought at the store the other day'

b. Ayşe-nin duy-duđ-un-a göre Sare deprem-de vefat
Ayşe-GEN hear-FN-3SG-DAT according to Sare earthquake-LOC death
et-miş.
do-REP.PAST.

'According to what Ayşe heard, Sare died in the earthquake.'

c. Piyanist bu parça-yı Polli-nin göster-diđ-i gibi çal-dı.
Pianist this piece-ACC Pollini-GEN show-FN-3SG like play-PAST
'The pianist played this piece like Pollini showed.' (i.e. *in the way in which* P.
showed it to be played)

d. Ali baba-sı-nın iste-diđ-i kadar başarılı-ı
Ali father-3SG-GEN want-FN-3SG as-much-as success-with
ol-a-ma-miş.
become-NEGABIL-NEG-REP.PAST

'(It is said that) Ali wasn't able to become as successful as his father wanted.'

Following Williams (1994), Kornfilt (2003) assumes theta role assignment/indexation of Agr through predication in order to account for Genitive subjects in these structures. As is the case with subject and predicate, there is predication between the nominal head and the modifier clause. This is exemplified in (38a-b).

- (40) a. *Biz_i [birbirimiz-in_i sınav-ı geç-me-miz]-i
 we each other-1PL-GEN exam-ACC pass-NFN-1PL-ACC

 isti-yor-du-k.
 believe-PROG-PST-1PL
 Intended reading: ‘We wanted that ourselves should pass the exam.’
- b. (?) biz_i [birbirimiz-in_i sınav-ı geç-me-sin]-i
 we each other-1PL-GEN exam-ACC pass-NFN-3SG-ACC

 isti-yor-du-k.
 believe-PROG-PST-1PL
 ‘We wanted that each other should pass the exam.’

Along the lines of Kornfilt’s (2007) analysis, Agr (FinP) which licenses subject case determines the finite (opaque) domain so (39a-40a) are ungrammatical because there is agreement marker on the predicate so AgrP (FinP) does not allow binding from an upper domain. In (39b-40b) on the other hand there is default agreement marker. The embedded clause cannot form an opaque domain and though marginal, binding is accepted.

3.2.3.2 External D Head as Genitive Case Licenser

According to this approach it is the D⁰ with relevant phi features that checks Genitive case on the subject. D⁰ probes for a goal with matching phi features and as a reflex of this feature valuation either the probe attracts the goal to [Spec DP] or through long distance Agree checks Genitive case on the subject.

Following Miyagawa's (1993) analysis of the Nominative/Genitive conversion in Relative Clauses and CNPCs in Japanese, Aygen (2003) proposes that there is an external nominal head that licenses genitive case in Turkish. In contrast to Kornfilt (2003), Aygen (2002) assumes different functional projections for Nominative and Genitive case licensing. The presence of the external nominal head is taken to be the evidence that genitive case licenser is external to the clause.

Aygen (2002) looks at Relative clauses and nominal complements which allow Genitive subjects. Aygen (2002) further notes that in Turkish, interrogative subordinate clauses are Relative clauses based on co-ordination and gap filling tests and declarative subordinate clauses are Complex NPs based on head insertion test.

Turkish interrogative clauses exemplified in (41a) can be coordinated with a relative clause as in (41b) and do not allow insertion of a lexical item to the gap position as in (41c) which is the case in Relative Clauses.

(41) a. Ben-Ø [Ali-nin git-tiğ-i zaman]-ı bil-iyor-du-m.
 I-NOM Ali-GEN go-DIK-agr time-ACC know-PROG-PAST-1SG
 'I knew the time when Ali went.'

b. Ben- Ø [Ali-nin git-tiğ-i zaman]-ı ve Hasan-ın bin-diğ-i
 I-NOM Ali-GEN go-DIK-agr time-ACC and Hasan-GEN get on-DIK-agr
 uç-ağ-ı bil-iyor-du-m.
 plane-ACC know-PROG-PAST-1SG
 'I knew the time when Ali went and the plane that Hasan got on'

- c. *Ben Ali-nin dün git-tiğ-i zaman-ı bil-iyor-du-m.
 I-NOM Ali-GEN yesterday go-DIK-agr time-ACC know-PROG- PAST-1SG
 ‘*I know when Ali left yesterday.’

Declarative subordinate clauses on the other hand are compatible with an external head as exemplified in (42a-b).

- (42) a. Ben- Ø [Hasan-ın Jale-yi gör-düğ-ün]-ü bil-iyor-um.
 I-NOM Hasan-GEN Jale-ACC see-DIK-AGR-ACC know-PROG-1SG
 ‘I know that Hasan saw Jale’

- b. Ben- Ø [Hasan-ın Jale-yi gör-düğ-ü] gerçeğ-in-i / iddia-sı-nı
 I-NOM Hasan-GEN jale-ACC see-DIK-AGR fact-AGR-ACC/claim-3agr-acc
 bil-iyor-um.
 know-PROG-1SG
 ‘I know the fact/the claim that Hasan saw Jale’

When the head noun is not overt as in (42a), Aygen (2002) assumes a null head.

Aygen (2002) uses ambiguity test to determine the position of Genitive subjects in the structure. In the following examples, the head noun ‘probability’ can take scope over the Genitive subject in (43a) and nominative subject in (43b). However, only Genitive subject can take scope over the head noun.

- (43) a. [[Pırlanta ya da inci]-nin ucuzlama] ihtimal-i] % sıfır.
 Diamond or pearl-GEN get cheaper probability-3agreement 0%
- i. ‘The probability that diamonds or pearls become cheap is 0%’ (i.e. neither will become cheaper)
- ii. ‘The probability that diamonds become cheap or the probability that pearls become cheap is 0%.’ (i.e. either diamonds or pearls won’t become cheaper)
- Probability >[diamond or pearl]; [diamond or pearl] > probability

- b. [Pırlanta ya da inci]Ø yüz -de sıfır ihtimal-le ucuzla - yacak.
 Diamond or pearl-NOM hundred-loc zero probability-with become cheaper-will.
 ‘Diamonds or pearls will become cheap with the probability of zero %’ (i.e. neither will become cheaper)
- Probability >[diamond or pearl]; *[diamond or pearl] > probability

Based on this ambiguity test Aygen (2002) suggests that Genitive subject licensing position is higher than Nominative case licensing position. As indicated in the structures below genitive case licensing is external to the clause.

The subject DP moves to [Spec DP] for case purposes in covert syntax. The subject can take scope over the head noun as in (44a) or can remain within the scope of the head noun as in (44b).

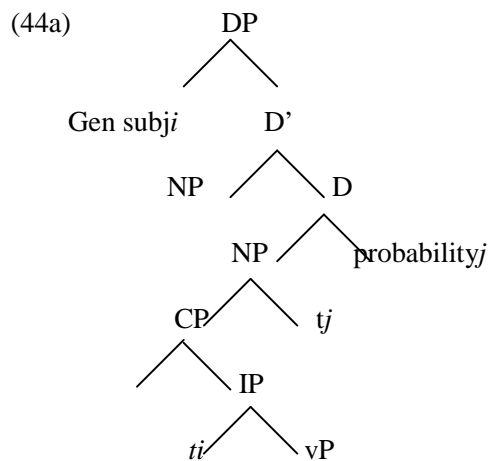

[diamond or pearl] > probability

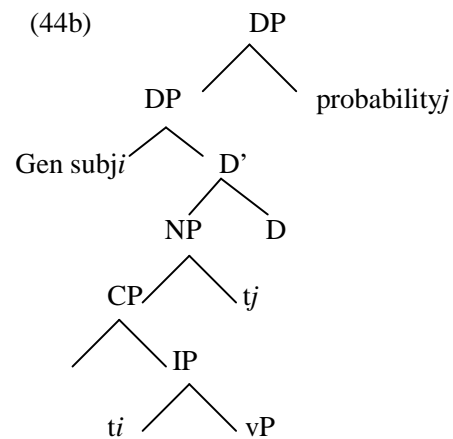

Probability >[diamond or pearl]; *[diamond or pearl] > probability

3.2.3.3 Nominal C as Genitive Case Licenser

Kural (1993) classifies nominalizers –DIK/-(y)AcAK as past and future tense morphemes respectively and –mA/mAK as infinitives. Kural further notes that –k segment of –DIK/-(y)AcAK nominalizers is the C head. He bases his arguments on ECM clauses in Turkish.

- (45) Ahmet- Ø [ben-i uyu-du-m] san-ıyor- Ø
 Ahmet-NOM I-ACC sleep-PAST-AGR think-PRES-AGR
 ‘Ahmet thinks I slept.’

The structure in (45) being an ECM clause does not have a CP projection and –k segment is also absent. Thus –k segment is the C head.

Moreover the presence of –k in embedded clauses determines binding domain of elements in the matrix clause.

- (46) a. Ahmet_i- Ø [pro_i Ankara-ya git-ti-ğ-i]ni san-ıyor- Ø.
 A.-NOM 3SG A.-DAT go-PAST-COMP-AGR-ACC think-PRES-AGR
 ‘Ahmet thinks he went to Ankara.’
- b. * Ahmet_i- Ø [pro_i Ankara-ya git-ti] san-ıyor- Ø.
 A.-NOM 3SG A.-DAT go-PAST think-PRES-AGR
 ‘Ahmet thinks he went to Ankara.’
- c. *Ahmet_i- Ø [pro_i Ankara-ya git-me-si]ni istiyor.
 A.-NOM 3SG A.-DAT go-INF-AGR-ACC want-PRES-AGR
 ‘Ahmet wants him to go to Ankara.’

The presence of –k, CP projection, creates an opaque domain in (46a) while in its absence embedded clause becomes a transparent domain for binding as in (46b-c) which violates binding requirements.

Taking –k segment as the C head implies that there is movement of T to C. Among the reasons Kural (1995) gives for suggesting that there is V to I to C movement is that embedded clauses receive case from the matrix clause, post-verbal constituents are barred in argument clauses and negative polarity items are licensed through c-command.

The embedded clause receives a case marking from the matrix clause.

(47) Ahmet- Ø [pro ev-e koş-tuğ-um]u bil-iyor-Ø.
 Ahmet-NOM 1SG home-DAT run-PAST-COMP-AGR-DAT believe-PRES-AGR
 ‘Ahmet believes that I ran home.’

The example above indicates that the verbal complex has moved from T to C head and has been licensed accusative case by the matrix T.

In Turkish, post-verbal constituents are adjoined to CP projection as argued by Kural (1992). However when the CP projection is an argument of the matrix clause then adjunction is prohibited (Chomsky, 1986).

(48) *Berna- Ø [[Ahmet-in git-ti-ğ-i]ni okul-a] duydu.
 B.-NOM A.-GEN go-PAST-COMP-AGR-ACC school-DAT hear-PAST-AGR
 ‘Berna heard that Ahmet went to school.’

As a consequence of the movement of the verb to C, post-verbal constituents are adjoined to CP projection and this yields ungrammaticality as exemplified by (48).

Negative Polarity Items (NPI) are licensed by Negation through c-command.

(49) a.* Ahmet-Ø [kimse-nin koş-tu-ğ-u]nu san-ıyor-Ø
 A.NOM no one-GEN run-PAST-COMP-AGR-ACC think-PRES-AGR
 ‘Ahmet thinks no one ran.’

b. Ahmet-Ø [kimse-nin koş-ma-dı-ğ-ı]nı san-ıyor-Ø
 A.NOM no one-GEN run-NEG-PAST-COMP-AGR-ACC think-PRES-AGR
 ‘Ahmet thinks no one ran.’

In (49a) the absence of Neg to c-command the embedded subject makes the structure ungrammatical whereas in (49b) the embedded verb moves to C position and c-commands the subject at [Spec TP].

As for the functional categories, Kural (1995) suggests Agr is not an independent head. Instead there is V to T to C movement and AGR features are carried over to C head by this movement as in Turkish, agreement morphology follows –k segment which is the C head.

However C head is nominal by nature, thus when the verb moves from T to C head agreement morphology is defined as nominal and genitive case is assigned to the subject.

3.2.3.4 *n* Head as Genitive Case Licenser

Ulutaş (2008) explains Genitive versus Nominative subject case licensing based on (non)defective nature of FinP. When FinP is phi complete then through Feature Inheritance Mechanism phi features of FinP percolate down to T head which in turn values the case of the subject DP as nominative.

When C head is defective as in the representations (c-d), either matrix little *v* checks accusative case on the embedded subject or a small *n* head with complete phi features comes into the derivation within the same lexical array of defective C and checks genitive case on the embedded subject as indicated in the following configurations.

(c) {V, Cdef}, {T, v}, {V, ...} (ECM Clauses – ACC on the subject)

(d) {*n*, Cdef}, {T, v}, {V, ...} (Argument Embedded Clauses – GEN on the subject)

Ulutaş (2008) takes –*k* part of the nominalizer –DIK as *n* head and suggests that because of the nominal nature of this *n* head possessive agreement markers appear on the embedded predicate.

In the examples below (50) is an argument –DIK clause and (52) is an adjunct –DIK clause. Both of the embedded clauses show possessive agreement on the predicate indicating the presence of *n* head but the embedded subject in (52) has nominative subject.

(50) Sen [dün biz-im okul-a git-me-dig-imiz]-i
you-NOM yesterday we-GEN school-DAT go-NEG-NML-1PL-ACC

zannet-ti-n.

think-PST-2SG

‘You thought that we didn’t go to school yesterday.’

(51)

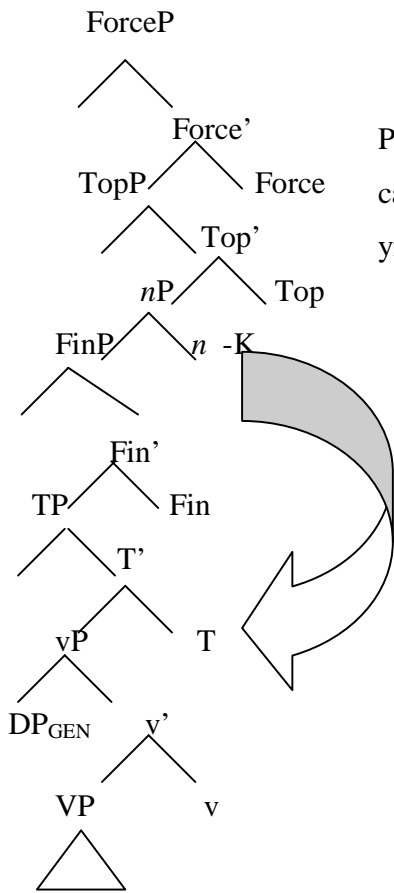

Phi feature transmission from *nP* to T head yields Genitive case on the subject. The nominal nature of the phi features yield nominal agreement on the embedded predicate.

As illustrated in the tree structure above in (51), C (FinP) is phi incomplete so feature transmission from C to T cannot occur. However there is another functional projection *nP* within the same lexical array of FinP with a complete set of phi features. The head of this functional projection is the *-k* part of the nominalizer *-DIK*. *nP* transmits its phi features to T head and the case of the subject in [Spec vP] is valued as genitive. Uninterpretable phi features of the probes are valued as gen-poss agreement.

Now we turn to the derivation of adjunct –DIK clause given in (52) below.

- (52) a. Sen [[dün biz okul-a git-me-dig-imiz] için]
 you-NOM yesterday we.NOM school-DAT go-NEG-NML-1SG for
 biz-i azar-la-dı-n.
 us-ACC reprimand-PST.2SG
 ‘You reprimanded us since we didn’t go to school yesterday.’

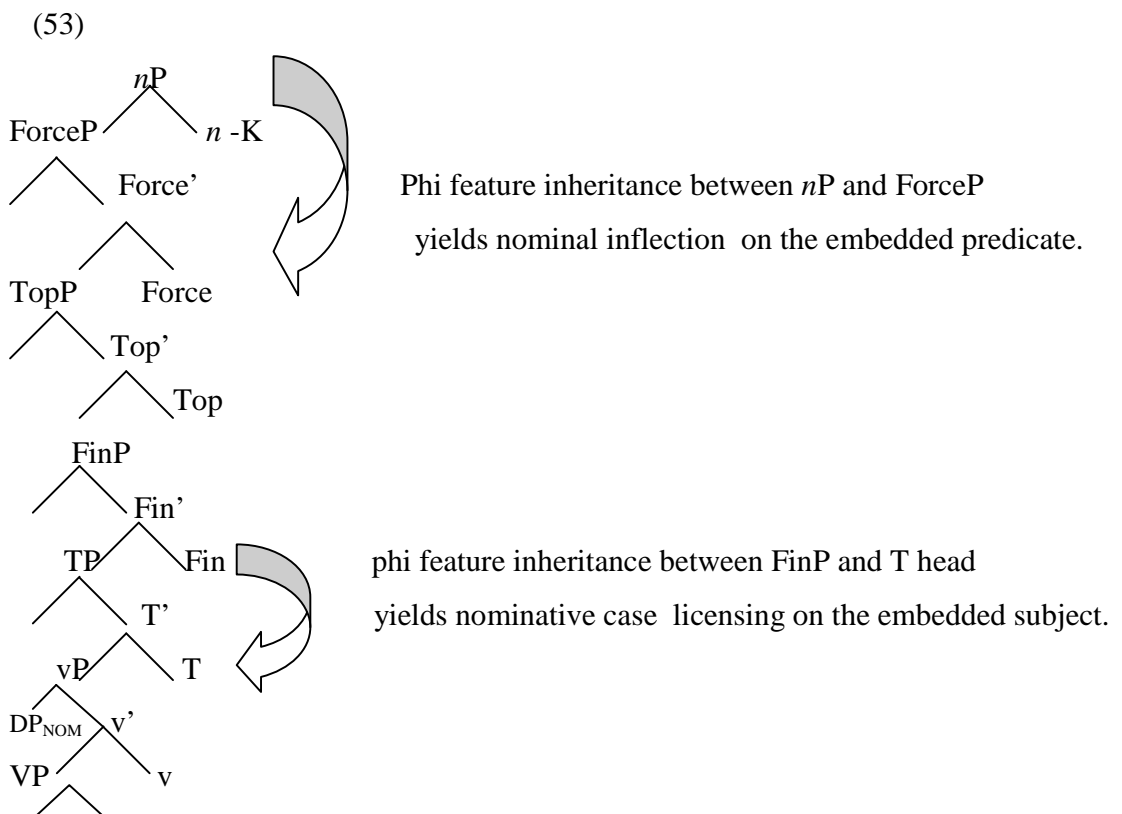

In (53), FinP is merged in the derivation with a complete set of phi features which the T head inherits. As feature percolation is from FinP to T head, Nominative case is licensed on the subject in [Spec vP]. Note that nominal inflection appears on the embedded predicate although phi features are inherited from FinP. Ulutaş (2008) holds

that nominal inflection is because of the *nP* projection over ForceP which checks its phi features with the ForceP.

In adjunct –DIK clauses with nominative subject two feature inheritance mechanisms are at work; one is between the FinP and the T head yielding Nominative case on the subject, the other is between the *nP* and the ForceP yielding nominal inflection on the embedded predicate.

Ulutaş (2008) takes the following examples adopted from Kennelly (1996) as an evidence for non-defective, phi complete FinP. In the structures (54b-55b) NPI licensing is not possible because subordinate clause has a phi complete FinP projection that licenses Nominative case and forms an opaque domain.

(54) a. Ben [kimse sigara iç -me-di] zannet-iyor-um
 I-NOM anybody-NOM cigarette smoke-NEG-PST think-PROG-1SG
 ‘I believe that nobody smoked.’

b. *(?) Ben [kimse sigara iç-di] zannet-m-iyor-um
 I-NOM anybody-NOM cigarette smoke-PST think-NEG-PROG-1SG
 ‘I don’t believe that anybody smoked.’ (Kennelly 1996)

(55) a. Ben [[kimse sigara iç -me-di-k-i] için]
 I-NOM anybody-NOM cigarette smoke-NEG-PST-NML-3SG for
 oda-yı temiz zannet-ti-m.
 room-ACC clean think-PST-1SG
 ‘I considered the room clean since nobody smoked in it.’

b. *Ben [[kimse sigara iç-di-k-i] için] oda-yı temiz zannet-me-di-m.

Intended Meaning: ‘I considered the room clean since nobody smoked in it.’

In contrast to (54b-55b), NPI licensing is possible in (56a-b).

(56) a. Ben [bu oda-da kimse-nin sigara
I-NOM this room-DAT anybody-GEN cigarette

iç-me-di-k-in]-i zannet-iyor-um.
smoke-NEG-PST-NML-3SG-ACC think-PROG-1SG

‘I believe that nobody smoked in this room.’

b. Ben [bu oda-da kimse-nin sigara
I-NOM this room-DAT anybody-GEN cigarette

iç -di-k-in]-i zannet-m-iyor-um
smoke-PST-NML-3SG-ACC think-NEG-PROG-1SG

‘I don’t believe that anybody smoked in this room.’

In (56a) NPI is licensed by Neg within the immediate clause in (56b) on the other hand, FinP is not phi complete so the embedded clause cannot form an opaque domain and NPI is licensed by Neg in the matrix clause.

3.3 Summary

This chapter has demonstrated that the distribution of Gen/Nom case licensing in complement clauses, in certain adjunct clauses, relative clauses, and CNPCs in Turkish.

In the last part of this chapter, previous analyses on Gen/Nom alternation in Turkish have been presented on the basis of the question whether Nom/Gen case licensing involve movement or not. This section has shown that within the Movement approach the analyses further differ from each other with respect to Nom/Gen case licensing functional projections.

CHAPTER FOUR

SUBJECT MARKING: GEN/NOM CASE LICENSING IN TURKISH

4.1 Introduction

The main concern of this chapter is to elucidate the case licensing mechanism for Genitive, and Nominative subjects in CNPCs in Turkish. In chapter two, we illustrated all possible variants of CNPCs with their structural properties for Dialect A and B. The basic question raised at this point is whether base generation or movement analysis can predict Gen/Nom case variation for Turkish data. If movement analysis explains Turkish data then the next question is whether different functional projections or the same functional projection with different features licenses nominative and genitive case.

The analysis will have implications for the nature of the functional categories and the clause structure in Turkish and basic tenets of the MP i.e. EPP (Chomsky 1981) and Case Filter (Chomsky 1980, 1981). The following section takes a brief look at the Gen/Nom case licensing in CNPCs in Turkish which reveal some problems for the previous approaches.

4.2 Gen/Nom Subject Case Licensing in CNPCs

The CNPCs that we will focus on in this chapter are illustrated below in (1a-g). The structural properties of these CNPCs have been discussed in detail in chapter two. Now

we turn to the syntactic analysis of Nominative/Genitive subject case licensing in these CNPCs.

(1) a. [[Sen yeni bir ev-e taşın-mış-sın] söylenti-si] gerçek değil.
you-NOM new one house-DAT move-PAST-2SG rumor-CM true not
‘The rumor that you moved to a new house is not true.’

b. [[Sen-in sınav-ı geç-e-me-diğ-in] haber-i] biz-i üz-dü.
you-GEN exam-ACC pass-ABIL-NEG-AGR_{NOM} news-CM we-ACC upset-PAST
‘The news that you couldn’t pass the exam upset us.’

Dialect B

c. [[Kitab-a hiçkimse-nin_i bak-ma-mış-tır_i] düşünce-sin-e]
book-DAT anybody-GEN look-NEG-PAST-MOD idea-CM-DAT
katıl-ıyor-um.
agree-PROG-1SG
‘I agree with the idea that nobody has looked at the book.’

Dialect A

d. Sen-in_i [*pro*_{i/j} saatlerce koş-tu-n_{i/j}] iddia-sı sadece bir yalan.
you-GEN for hours run-PAST-2SG claim-CM just a lie
‘The claim (about you) that you ran for hours.’
‘Your claim that ‘you ran for hours’

e. Sen-in_i [*pro**_{i/j} dün gece bayıl-dı_j] iddia-n_i gerçek değil.

you-GEN yesterday night faint-PAST-3SG claim-2SGPoss true not

‘Your claim that s/he fainted last night is not true.’

*‘Your claim that you fainted last night is not true.’

f. Sen-in_i [*pro**_{i/j} iflas et-miş-sin_j] haber-in_i biz-i üz-dü.

you-GEN bankruptcy get-PAST-2SG news-2SGPoss we-ACC upset-PAST

‘Your news that ‘you went bankrupt’ upset us.’

* ‘Your news that you went bankrupt upset us.’

g. Sen-in_i [*pro*_{i/j} gizlice evlen-di_{i/j}] söylen-ti-si inandırıcı değil.

you-GEN secretly get married-PAST-3SG rumor-CM convincing not

‘The rumor (about you) that you got married secretly is not convincing.’

‘Your rumor that s/he got married secretly is not convincing.’

Note that the CNPC variants differ from each other in the following manner.

(i) In (1a) the complement of the head noun is in the form of a verbal clause.

The embedded predicate is fully inflected for tense and verbal agreement markers. The subject bears Nominative case.

(ii) In (1b) the complement of the head noun is in the form of a nominalized clause. The embedded predicate is marked with the nominalizer –DIK and the agreement markers are from the nominal agreement paradigm. The subject bears Genitive case.

(iii) The NPI structure in (1c) exemplifies a CNPC variant for Dialect B. The embedded predicate is inflected for tense and agreement. The nominal DP is marked with Genitive case and interpreted to be the subject in Dialect B.

(iv) The embedded predicate in (1d) is fully inflected for tense and agreement markers. The DP nominal bears Genitive case marker. Remember that for Dialect A speakers, the Genitive nominal is not the subject in this clause. The head noun bears compound marker and *pro* in the embedded clause can be co-indexed with the genitive nominal.

(v) The embedded predicate in (1e) is inflected for tense. The verb is marked with third person agreement marker which is covert, i.e. \emptyset . The DP nominal bears Genitive case and the external nominal head bears nominal agreement marker. As discussed in section 2.5, *pro* cannot be co-indexed with the genitive nominal when the head noun bears possessive agreement markers.

(vi) In (1f) the embedded predicate is inflected with tense and agreement morphology. The head noun is marked with possessive agreement markers which agree in person with the genitive nominal and hence co-indexation of *pro* and the genitive nominal is not possible.

(vii) The embedded predicate in (1g) bears tense and third person agreement markers. The head noun is marked with compound marker and co-indexation of *pro* and the genitive nominal is possible.

We will discuss Nom/Gen case licensing in (1a-b) and Nom/Gen case alternation in structures similar to (1c) for Dialect B in section 4.3.3.2, and the appearance of Genitive case marked nominal in (1d-g) for Dialect A speakers in section 4.3.3.3.

The following sections illustrate how previous analyses account for the CNPCs in Turkish which will lead to a new analysis of subject case variation in section 4.3.3.

4.3 Case Licensing

Within the two existent analyses for nominative and genitive case licensing i.e. Base generation analysis versus Movement analysis, each line of argumentation makes different predictions with respect to the nature of the case licensing configuration (Spec-Head) as well as EPP and the relation Agree.

We now turn to discuss the implications of the two approaches to case licensing. In section 4.3.1 we focus on CNPCs under Movement Analysis and in section 4.3.2 under Base Generation Analysis. Section 4.3.3 articulates Features as Case Licenser Approach and proposes a new analysis for CNPCs.

4.3.1 Different Functional Projections as Case Licenser

As mentioned in the third chapter, within the movement analysis of case licensing, a number of different approaches to Nom/Gen subject case licensing have been proposed for Turkish. In the following sub-sections we will discuss these approaches in

accounting for the subject case realization in CNPCs with the aim of determining whether they can account for subject case in these constructions.¹

4.3.1.1 Nominal AGR as Case Licenser in CNPCs

As illustrated with ample data in section 3.2.3.1, Kornfilt (2003) holds that verbal Agr licenses Nominative case and nominal Agr licenses Genitive case. She holds that in order to license case on the subject, Agr should be licensed through (i) categorial match (whether the subordinate clause is fully nominal or not), (ii) referential indexing (whether the subordinate clause is an argument or not) or (iii) through predication (in relative clauses).

Within the assumptions of this approach, Nominative case on the subject in (2a) and Genitive case on the subject in (2b) are predicted. The categorial features of Agr determine the case marker on the subject.

- (2) a. Sen yeni bir ev-e taşın-mış-sın söylenti-si gerçek değil.
you-NOM new one house-DAT move-PAST-2SG rumor-CM true not
'The rumor that you moved to a new house is not true.'

¹ Within the studies discussed under Movement Analysis and Base Generation analysis, some researchers propose derivation of structures similar to the ones exemplified in (1a-b) (Aygen 2002, Kornfilt 2003), while some others do not (Ulutaş 2008, Kural 1993, Öztürk 2005). The aim of this part is to find out how these analyses can deal with the case variation in CNPCs in (1a-c) within the proposed assumptions.

b. Sen-in sınav-ı geç-e-me-diğ-in haber-i biz-i üz-dü.
you-GEN exam-ACC pass-ABIL-NEG-AGR_{NOM} news-CM we-ACC upset-PAST
'The news that you couldn't pass the exam upset us.'

The embedded predicate in (2a) is fully inflected for tense and verbal agreement markers. The subject which is base generated in [Spec VP] moves to [Spec AgrP] for case purposes. Agr is verbal and hence licenses Nominative case on the subject.

In (2b), on the other hand, the embedded predicate is inflected for nominal agreement markers. Case licensing through categorial match is not possible as –DIK clause with a CP projection under DP projection is nominal (although not fully).² Then Genitive case is licensed through referential indexing as the clause is a nominalized noun-complement clause.

The grammaticality of the following CNPC in Dialect B, on the other hand, is not expected by this analysis.

² Kornfilt (2003) suggests that –DIK/(y)AcAK clauses are not fully nominal while –mA clauses are fully nominal. The reasons Kornfilt (2003) gives for suggesting that –DIK/(y)AcAK are not fully nominal is that tense interpretation is allowed to a certain extent, plural marker and determiners associated with nominal projections are not licit and Wh- operator which is associated with verbal projections are compatible within –DIK/(y)AcAK clauses. See section 3.2.3.1 for the relevant examples.

(2) c. Kitab-a hiçkimse-nin bak-ma-mış-tır düşünce-sin-e
book-DAT anybody-GEN look-NEG-PAST-MOD opinion-CM-DAT

katıl-ıyor-um.

agree-PROG-1SG

'I agree with the opinion that nobody would have looked at the book.'

The embedded predicate is fully inflected for tense and third person verbal agreement markers which are null. Under Kornfilt's approach Nom case is expected on the subject as the categorial feature of Agr is verbal but the subject bears Genitive case.

4.3.1.2 External D Head as Case Licenser in CNPCs

Aygen (2002) suggests that it is the Epistemic Modality on T and Mood on C that licenses Nom case and the external nominal head that licenses Gen case as discussed in detail in sections 3.2.1.2 and 3.2.3.2.

When Nom case licensing heads are defective, the external nominal functional head licenses Gen case on the subject. Based on the distribution of agreement markers, Aygen holds that what is missing in Gen subject constructions in contrast to Nom subject constructions is Mood.

Now we turn to the derivations of the CNPCs given in (2a) and (2b). In (2a) there is a verbal complement clause under the DP projection. There is an overt external

nominal head ‘*söylenti*’ but the subject is licensed Nom case. This is what this approach predicts based on the assumptions mentioned above.

- (2) a. Sen yeni bir ev-e taşın-mış-sın söylenti-si gerçek değil.
 you-NOM new one house-DAT move-PAST-2SG rumor-CM true not
 ‘The rumor that you moved to a new house is not true.’

(3)

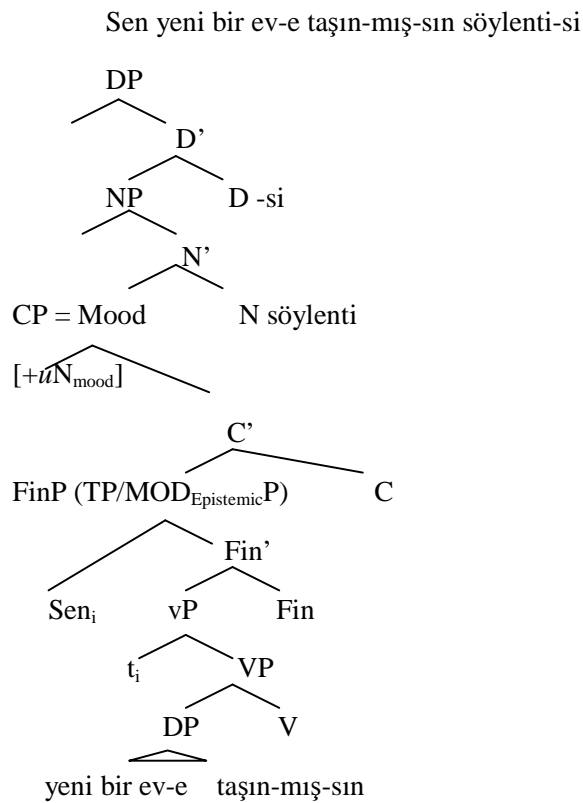

Nominative case licenser heads, C and FinP (TP) are not defective; hence case is licensed on the subject clause internally. The subject which is base generated in [Spec vP] moves to [Spec FinP] position and it is licensed Nom case.

Under this line of analysis Gen case marking on the subject in (2b) is also predicted. In contrast to (2a), the agreement markers on the embedded predicate in (2b) indicate the absence of Mood. As case licenser is defective, the subject DP moves to [Spec DP] for case purposes. Movement of the subject is not blocked since the case licensing functional categories within CP projection are defective as illustrated in (4) below.

- (2) b. Sen-in sınav-ı geç-e-me-diğ-in haber-i biz-i üz-dü.
 you-GEN exam-ACC pass-ABIL-NEG-AGR_{NOM} news-CM we-ACC upset-PAST
 ‘The news that you couldn’t pass the exam upset us.’

(4)

(2b) Sen-in sınav-ı geç-e-me-diğ-in haber-i biz-i üz-dü.

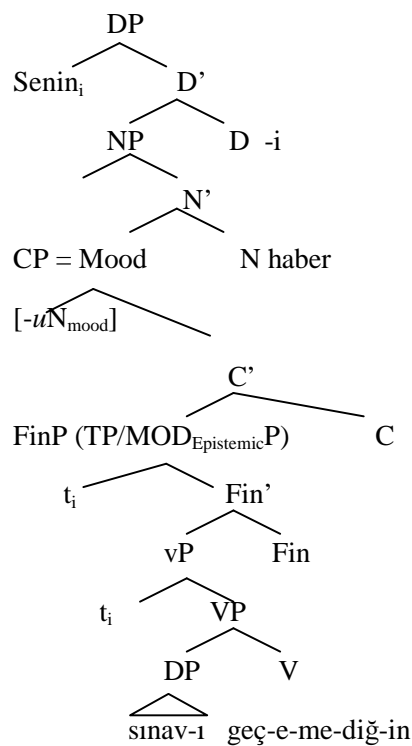

Case is licensed on the subject clause externally by the nominal head. Clause internal agreement marker is taken just as a morphological indication of this case checking.

However this analysis also falls short of explaining the derivation of (2c) for Dialect B.

(2) c. Kitab-a hiçkimse-nin bak-ma-mış-tır düşünce-sin-e
book-DAT anybody-GEN look-NEG-PAST-MOD opinion-CM-DAT

katıl-ıyor-um.

agree-PROG-1SG

‘I agree with the opinion that nobody looked at the book.’

C head is not defective as the mood marker is not from the nominal agreement set which indicates defective Mood; however Genitive case marker appears on the subject. Under the assumptions of this approach movement of the subject is not expected as case licensing heads are not defective however the subject DP seems to have moved to [Spec DP] and Gen case is licensed on the subject. Then what this analysis should account for is what triggers movement of the subject to [Spec DP]. Given that case licensing functional heads C and FinP are not defective, the movement of the subject remains as a problem.

If we assume that there is no movement and case is checked on the subject through Long Distance Agree, the structure still poses a problem for case checking

mechanism. We expect case checking to be blocked by CP which is not defective.

However case checking is not blocked and Genitive case is licensed on the subject.

4.3.1.3 Nominal C as Case Licenser in CNPCs

Within the framework of Kural (1993) who takes –k segment of –DIK/(y)AcAK nominalizers as the nominal C head, as discussed in section 3.2.3.3, Agr is not an independent functional projection but features carried over to C head through V to T to C movement.

This approach accounts for the nominative case marked subject in (2a) and genitive case marked subject in (2b).

(5)

(2a) Sen yeni bir ev-e taşın-mış-sın söylenti-si (b) Sen-in sınav-ı geç-e-me-diğ-in haber-i

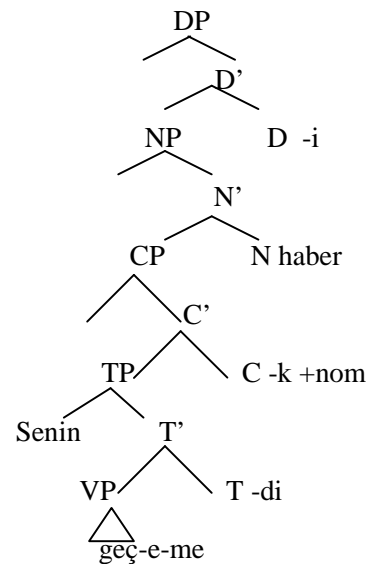
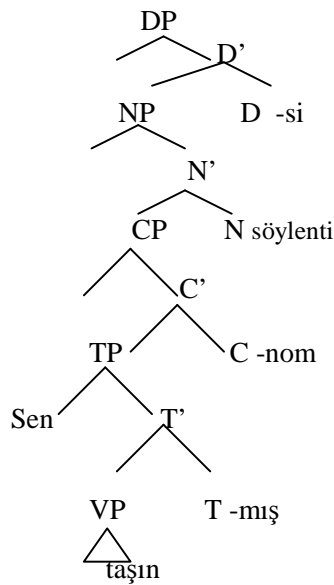

As represented in the tree structures in (5) above, in (2a) C projection is not nominal in nature and the embedded predicate is fully inflected for tense and verbal agreement markers. In (2b), on the other hand, C head is nominal and the predicate is inflected for nominal agreement markers. In accordance with the categorial nature of C heads, Nom case is licensed in (2a) and Gen case in (2b).

This approach seems to account for the structure in (2c) for Dialect B. If the C projection is assumed to be nominal then Gen case marking is expected on the subject.

(2) c. Kitab-a hiçkimse-nin bak-ma-mış-tır düşünce-sin-e
 book-DAT anybody-GEN look-NEG-PAST-MOD opinion-CM-DAT

katıl-ıyor-um.

agree-PROG-1SG

‘I agree with the opinion that nobody would have looked at the book.’

The problem with this line of analysis is that in (2a) and (2b) the nominal and verbal nature of C head is reflected on the inflectional morphology of the embedded predicate. When C is nominal, –k segment of the –DIK nominalizer occupies C position. In (2c) on the other hand assuming nominal C remains as an ad hoc solution as this is not reflected on the inflectional morphology of the predicate. This approach also falls short of explaining Nom/Gen subject case variation in adjunct –DIK clauses exemplified below in (6a-b).

(2) a. Sen yeni bir ev-e taşın-mış-sın söylenti-si gerçek değil.
 you-NOM new one house-DAT move-PAST-2SG rumor-CM true not
 ‘The rumor that you moved to a new house is not true.’

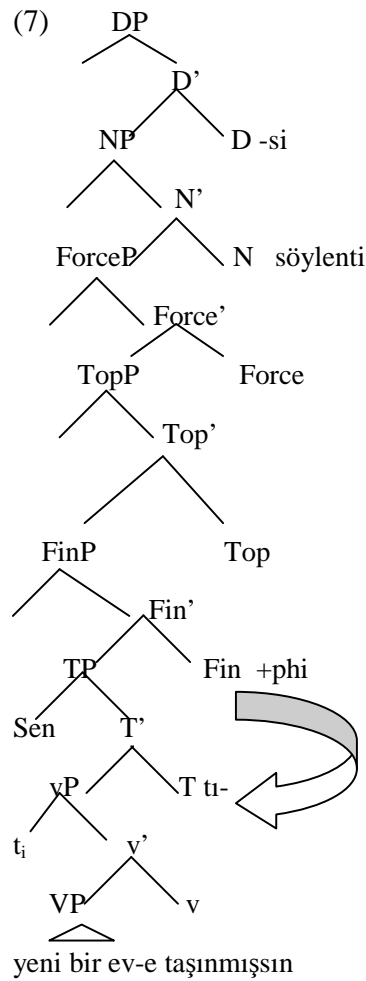

As illustrated in the tree structure above in (7), FinP with complete phi features is merged and T inherits these uninterpretable phi features. T head Agrees with the goal in [Spec vP] and values its case as Nominative. Given that there is no nP projected in the

structure and the phi features inherited from the FinP are not nominal, verbal inflection on the embedded predicate is predicted.

Now we turn to the derivation of (2b) under this approach.

- (2) b. Sen-in sınav-ı geç-e-me-diğ-in haber-i biz-i üz-dü.
 you-GEN exam-ACC pass-ABIL-NEG-AGR_{NOM} news-CM we-ACC upset-PAST
 ‘The news that you couldn’t pass the exam upset us.’

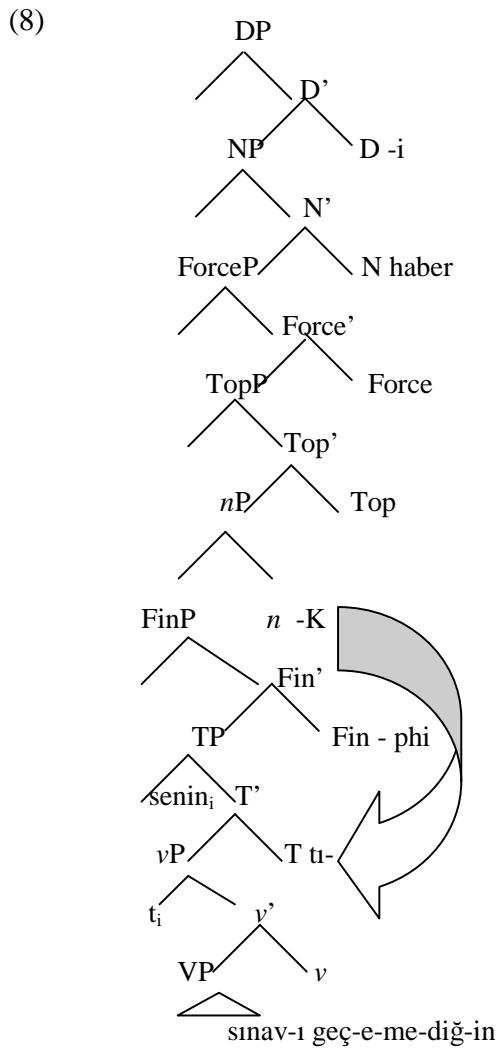

As indicated in the representation above, FinP is phi incomplete in (2b). T head inherits phi features from *nP* projection which selects a phi incomplete FinP. T head Agrees with the embedded subject and licenses Genitive case. Nominal nature of the phi features of *nP* yields possessive agreement on the embedded predicate.

As is the case with the previous analyses, this line of analysis predicts Nom subject in (2c) for Dialect B. As illustrated below FinP is phi complete so *nP* projection is predicted to be missing.

(2) c. Kitab-a hiçkimse-nin bak-ma-mış-tır düşünce-sin-e
 book-DAT anybody-GEN look-NEG-PAST-MOD opinion-CM-DAT

katıl-ıyor-um.

agree-PROG-1SG

‘I agree with the opinion that nobody would have looked at the book.’

However the subject is marked with genitive case. If it is the *nP* projection transmitting its phi features to T head in the presence of a phi incomplete FinP and licensing genitive case to the subject with T head, (2c) remains as a problem for this analysis. Genitive case appears on the subject when FinP is phi complete and *nP* projection is not projected.

Although the derivations of (2a-b) are possible in all analyses, (2c) which is grammatical for Dialect B speakers has revealed problems for each analysis. Section 4.3.2 turns to the analyses of CNPCs under Base generation Approach.

4.3.2 Base Generation Approach

As mentioned earlier in section 3.2.2.1, an alternative analysis to case checking has been proposed by Öztürk (2005) who assumes theta role assigning functional projections to be the positions for case licensing and referentiality. The subject DP is base generated in theta position, [Spec AgentP]. According to this analysis the subject is checked for its case and referentiality in this position and becomes an argument. Arguments remain in their base generated position and case is licensed in-situ unless attracted by a non-case related feature. As discussed in detail in section 3.2.2.1, Nominative subjects move to [Spec TP] for scope/discourse interpretive purposes.

In the base generation approach, T plays a role only in morphological realization of case. V moves to ThemeP and AgentP on its way to T. When V complex head moves to T head, T takes all the functional projections under its scope and allows morphological case realization in accordance with Mechanical Case Parameter repeated below.

(9) The Mechanical Case Parameter (Harley, 1995)

- a) If one case feature is checked structurally in a clause, it is realized as Nominative (mandatory case).
- b) If two case features are checked structurally in a clause the second is realized as Accusative.

- c) If three case features are checked structurally in a clause, the second is realized as Dative and the third as Accusative,
- d) The mandatory case in a multiple-case clause is assigned in the top/bottom AgrP.

For the Mechanical Case Parameter, case realization is also dependent on the properties of the clause. Thus the unmarked case in a DP projection is Genitive. If one case feature is checked structurally in a DP projection, it is realized as Genitive.

Now we will discuss how this kind of an analysis accounts for the CNPCs in (2a-b-c). (10) is a representation of clause architecture within the base generation approach of Öztürk (2005).

(10)

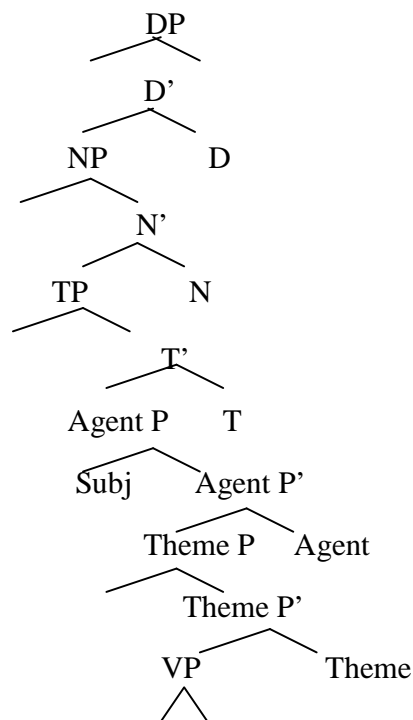

Under the phrase structure given above in (10) the subjects are base generated in [Spec AgentP]. The case feature of the subject DP is checked by AgentP but it is morphologically realized by TP. V moves through the functional projections ThemeP-AgentP on its way to T. When V-T complex head is formed, T head realizes the first case feature as Nominative.

Under the assumptions of the Mechanical Case Parameter, Nominative case on the subject is expected in (2a). T morphologically realizes the case feature of the subject in [Spec AgentP] as Nominative.

- (2) a. Sen yeni bir ev-e taşın-mış-sın söylenti-si gerçek değil.
 you-NOM new one house-DAT move-PAST-2SG rumor-CM true not
 ‘The rumor that you moved to a new house is not true.’

As for Genitive subjects, the Mechanical Case parameter makes some other assumptions. In (2b) and (2c) the subject base generated in [Spec AgentP] moves from [Spec TP] to as high as [Spec CP].³

³ Öztürk (2005) suggests a similar analysis for ECM constructions in Turkish.

- (1) Ali Ayşe-yi elma-yı ye-di sanıyor.
 Ali Ayşe-ACC apple-ACC eat-past thinks
 ‘Ali believes Ayşe to have eaten the apple.’

The ECM structure in (1) takes the following derivational steps. The embedded subject ‘Ayşe’ raises from [Spec AgentP] to [Spec TP] to embedded [Spec CP] and hence it is not within the scope of the embedded T when morphological case realization applies. The embedded T realizes Accusative case on the embedded object ‘elma’. The matrix T on the other hand realizes Nominative case on the subject and realizes the second structural case Accusative on the embedded C. This case feature is realized on the embedded subject at [Spec CP].

(2) b. Sen-in sınav-ı geç-e-me-diğ-in haber-i biz-i üz-dü.

you-GEN exam-ACC pass-ABIL-NEG-AGR_{NOM} news-CM we-ACC upset-PAST

‘The news that you couldn’t pass the exam upset us.’

c. Kitab-a hiçkimse-nin bak-ma-mış-tır düşünce-sin-e

book-DAT anybody-GEN look-NEG-PAST-MOD opinion-CM-DAT

katıl-ıyor-um.

agree-PROG-1SG

‘I agree with the opinion that nobody would have looked at the book.’

At the point of morphological case realization, the subject is as high as CP projection and hence the embedded T cannot realize the case feature on the subject as Nominative. The structure is a DP projection; therefore, as predicted, Genitive case is realized on the subject.

This approach accounts for the distribution of Gen/Nom subjects assuming that, Nominative subject is under the scope of T and Genitive subject is not within the scope of the embedded T at the point where case is realized. However the inflectional morphology on the embedded predicate in (2b-c) differs from each other. If Genitive subjects are licensed within the same projection in (2b-c), the appearance of nominal inflectional morphology on the embedded predicate in (2b) versus the verbal inflectional morphology on the embedded predicate in (2c) for Dialect B remains as a problem for this analysis.

4.3.3 Features as Case Licenser

This section introduces the basic tenets of features as case licenser analysis. This approach has the advantage over the previous approaches in that it assumes the same target position for Nom/Gen subjects.

4.3.3.1 Supercategorial Theory of CP/DP Parallelism

Hiraiwa (2005) has recently proposed that genitive and nominative licensing functional projections are the same projections with different features in each instance. Hiraiwa (2005) bases his arguments on the parallelism between CP and DP projections which he takes to be surface variations of the same structure.

There are languages such as Japanese (Hiraiwa 2005) and Cuzco Quechua (Lefebvre and Muysken 1988) which mark case and agreement in nominals and in certain clauses in the same way. As illustrated in detail in chapter two and three, there is a structural parallelism between nominals and certain clauses in Turkish as well.

Hiraiwa labels this Supercategorial Theory of CP/DP Symmetry. This is illustrated below.

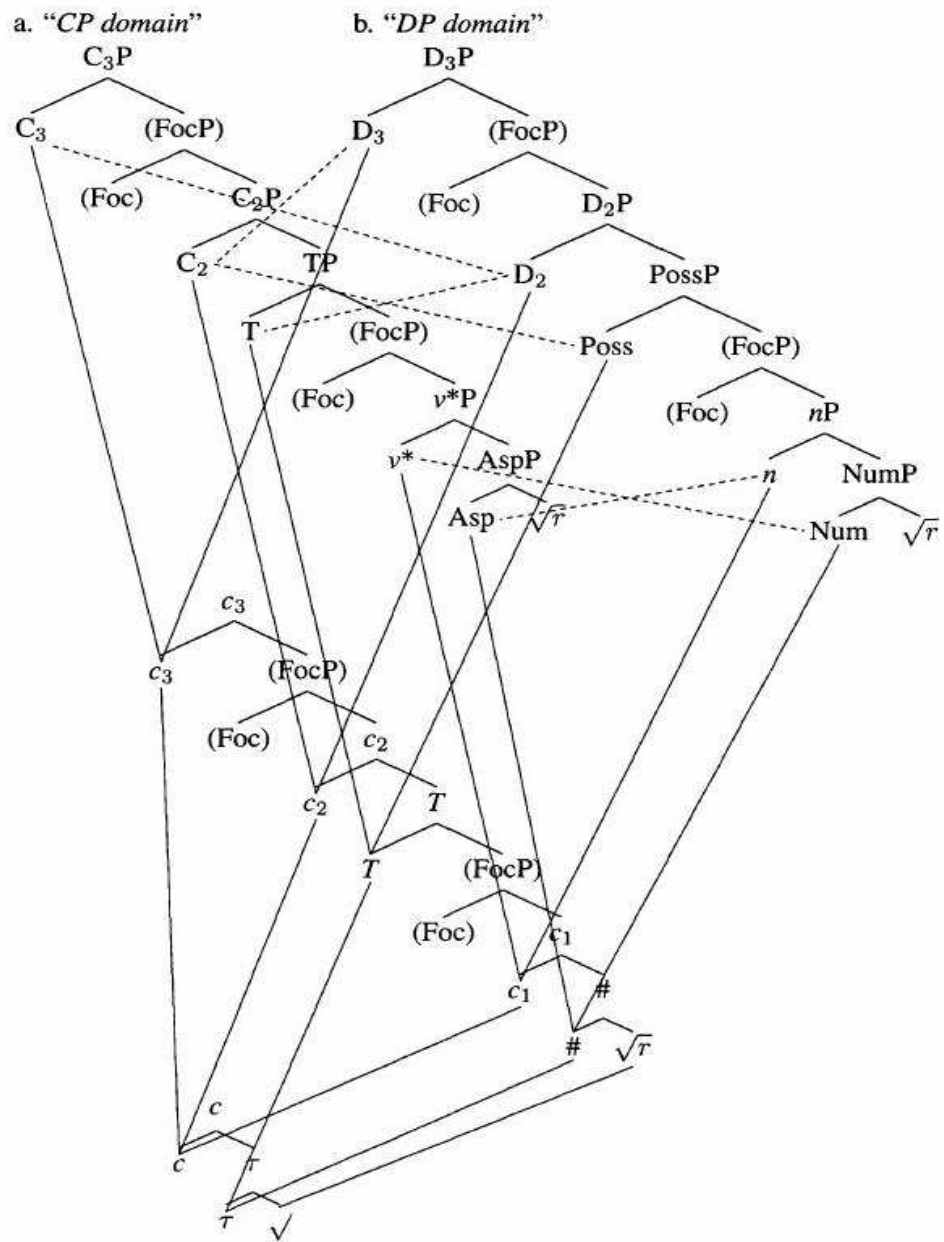

Supercategorical Theory of CP/DP Symmetry (Hiraiwa 2005)

The supercategorical structure with the phase heads c_1 , c_2 and c_3 can surface as a CP domain as illustrated in (a) or as a DP domain as in (b).

Within this analysis the crucial factor determining the categorial status of the domains is the feature [+/-N] inserted at phase heads at Transfer. The features inserted at phase heads c_1 , c_2 and c_3 determine the category of the complement of the phase head, giving rise to a CP projection when the inserted feature is [-N] or a DP projection when the feature is [+N].

Note that CP projection can also be represented with the projections of Rizzi's (1997) Split CP hypothesis. Then C_3 is the ForceP, C_2 is the FinP. In a similar line D_3 is DemP and D_2 is DefP.

Supercategorial theory makes mixed structures possible as DP and CP domains have the same structure. From c_1 to c_3 both [-N] and [+N] features can be inserted and categorial determination can take the following steps (Hiraiwa 2005):

- Phase One c_1 :
 - i. $v^*+\# + \sqrt{r}$: verb
 - ii. $n+\# + \sqrt{r}$: noun
- Phase Two c_2 :
 - i. C_2+TP : Extended Verbal Projection of VP
 - ii. D_2+TP : Extended Nominal Projection of VP (=Gerunds)
- Phase Three c_3 :
 - i. C_3+C_2P : Extended Verbal Projection of FinP
 - ii. D_3+C_2P : Extended Nominal Projection of FinP (=Clausal Nominalization)

c_2 is the locus of uninterpretable phi features for the internal syntax and c_3 is the locus of uCase and inherent phi features for the external syntax. Once c_2 is merged uninterpretable phi features percolate down to T head. Case licensing is carried out by c_2 -T amalgamate.

c_3 plays a crucial role in subject case licensing. If c_3 gets [+N] feature at Transfer then c_2 -T amalgamate licenses Genitive case on the subject, but the subject is marked with nominative case if c_3 gets [-N] feature at Transfer as illustrated below.

Agree (c_2 -T, g)

- a) value (c_2 -T \rightarrow g uninterpretable case genitive) if c_3 gets [+N]
- b) value (c_2 -T \rightarrow g uninterpretable case nominative) irrespective of a categorical feature of c_3 . (Hiraiwa 2005)

Based on data on Japanese Gen/Nom conversion examples Hiraiwa defines some other preconditions for Gen/Nom conversion. These are illustrated in examples (11-13).

In Japanese Gen/Nom conversion is only allowed in clauses whose predicates are nominalized.

- (11) a. [Kinoo John-no kat-ta hon]-wa omosiro-i.
 yesterday John-Gen buy-Pst.Adn book-Top interesting-Prs.
 ‘The book which John bought yesterday is interesting.’
- b. [Dare-ga/*no ki-te-mo] kamaimas-en.
 [whoever-Nom/Gen come-Cond-Q] care-Neg.Pr
 ‘I don’t care whoever will come.’
- c. [John-ga/*no ku-reba] minna yorokobu yo.
 [John-Nom/Gen come-Cond everyone be.pleased-Prs Part.
 ‘Everyone will be delighted if John comes.’

- d. Omae-ga/*no ko-i!
 you-Nom/Gen come-Imp
 ‘(You) Come here!’

The embedded predicate of the example (11a) is nominal while it is not in (11b-d). Note that only when the predicate has predicate adnominal form, the subject bears Genitive case.

The following adjunct clauses seem to challenge this pre-condition. (12a) is an example of a focus construction and (12b-c) are adjunct clauses. The embedded predicates have nominal form but the subjects can bear only nominative case.

- (12) a. John-ga/*no genki-na no-da.
 John-Nom/*Gen healthy-Prs.Adn C-CPL
 ‘It is that John is healthy.’

- b. John-ga/*no genki-na no-de.
 John-Nom/*Gen healthy-Prs.Adn C-OBL
 ‘Because John is in good health...’

- c. John-ga/*no genki-na no-ni
 John-Nom/*Gen healthy-Prs.Adn C-DAT
 ‘Although John is in good health....’

Hiraiwa (2005) proposes the following precondition for genitive case licensing. The c_2 -T system selected by c_3 must become a goal of a higher probe which is formulated in the following way.

- a) Select (c_2 -T) [Internal relation]
- b) Select (c_3 , c_2 -T)
- c) Agree (x, c_3) [External relation]

Arguments have an external relation with another probe, however adjuncts are “more grammaticalized” in this sense and hence Genitive case licensing is not possible.

Finally Hiraiwa (2005) argues that when there is an overt non-affixal complementizer Nom/Gen conversion is not licit. c_2 -T amalgamate is blocked, hence the predicate is not in the nominal form and Genitive case cannot be licensed on the subject.

- (13)* [[Mary-ga [John-no t_i kat-ta to] omottei-ru] hon_i]
 Mary-Nom John-Gen buy-Pst.End C think-Prs.Adn book
 ‘The book which Mary thinks that John bought.’

In the presence of the overt complementizer ‘to’ in (13), c_2 -T cannot form an amalgamation to license Genitive case on the subject. The embedded predicate is not in the nominal form and the subject bears Nominative case.

As an illustration of these defined properties for Genitive case licensing Hiraiwa (2005) analyzes the following complement clause from Turkish.

- (14) [Ahmet-in ben-i sev-diğ-in]-i bil-iyor-um.
 [Ahmet-3.GEN I-ACC love-Nml-3sg.Poss]-Acc know-Prs.Prog.-1Sg.
 ‘I know that Ahmet loves me.’

The tree structure and the derivational steps of this structure are given below in (15).

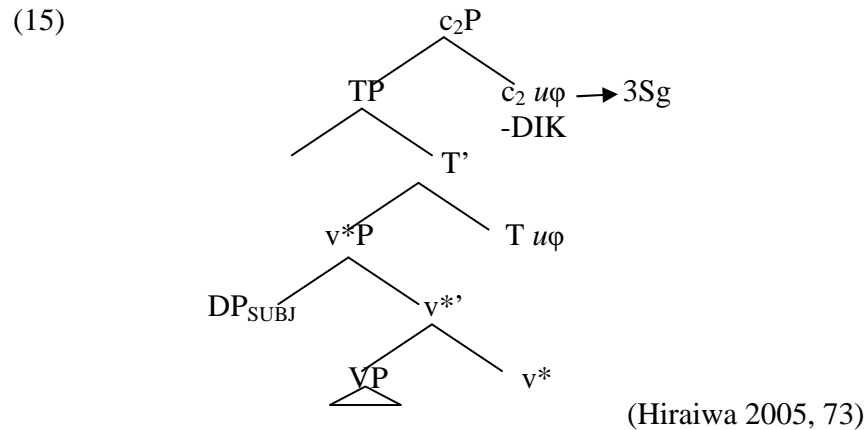

c_2 transmits its uninterpretable phi features to T head and c_2 -T amalgamate Agrees with the subject in [Spec vP]. The feature inserted at c_3 is [+N], hence c_2 -T values Genitive case on the subject. Note that possessive agreement appears on the embedded predicate. Hiraiwa takes this as an indication of Agree between the subject DP and the c_2 -T.

In the following sections we turn to the analyses of CNPCs within this approach.

4.3.3.2 Features as Case Licenser in CNPCs

As discussed in section 4.3.3.1, the features [+/-N] inserted at phase heads c_2 and c_3 determine the nature of their complement domain and the case marker on the subject. [+/-N] insertion at phase heads c_2 and c_3 has four logical possibilities which is illustrated in (16) below.

(16)

- a) $c_2 [+N]$ $c_3 [+N]$ *the predicate is nominalized and the subject bears Gen case*
- b) $c_2 [-N]$ $c_3 [-N]$ *the predicate is not nominalized and the subject bears Nom case*
- c) $c_2 [+N]$ $c_3 [-N]$ *the predicate is nominalized and the subject bears Nom case*
- d) $c_2 [-N]$ $c_3 [+N]$ *the predicate is not nominalized and the subject bears Gen case*

In Turkish, all four variations are observed. (16a) is the configuration of a nominalized clause while (16b) is the configuration of a finite subordinate clause. The variations given in (16c-d) are marginal and restricted to some specific constructions and/or speakers as will be discussed in the following sections.

Genitive case on the subject is not licensed in matrix clauses in Turkish as the ungrammaticality of the following example suggests.

(17) *Ben-im git-ti-m.

I-GEN go-PAST-1SG.

'I went.'

This is predicted by this analysis given that c_2 -T selected by c_3 is not a goal of a higher probe, the structure is fully grammaticalized and hence Genitive case is not licensed.

Hiraiwa's analysis of case licensing makes the following predictions when applied to CNPCs. In (2a) repeated below as (18), the categorial feature [-N] inserted at phase c_2 makes the complement domain of this phase verbal.

- (18) Sen yeni bir ev-e taşın-mış-sın söylenti-si gerçek değil.
 you-NOM new one house-DAT move-PAST-2SG rumor-CM true not
 'The rumor that you moved to a new house is not true.'

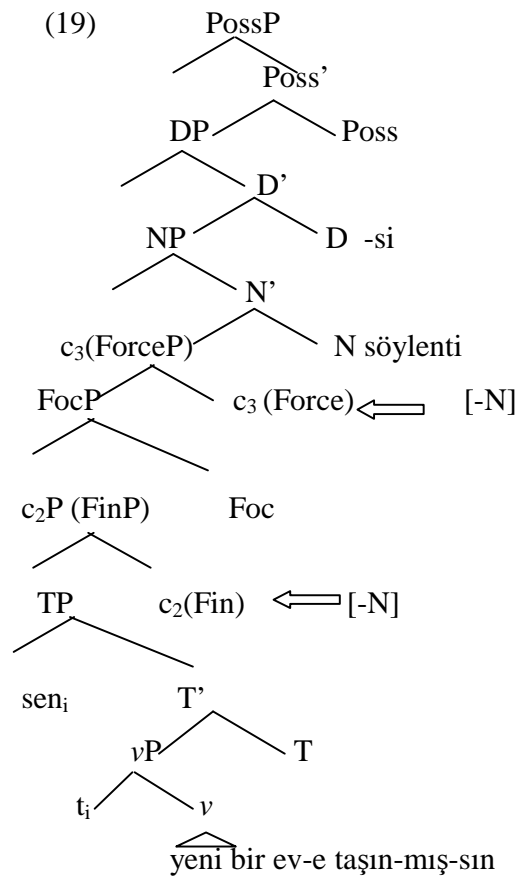

As represented in (19) above, c_2 transmits its phi features to T head. The feature inserted at c_3 is [-N], c_2 -T Agree with the subject DP base generated in [Spec vP]. The

uninterpretable phi features of c_2 -T are valued and as a reflex of this, c_2 -T amalgamation values Nominative case on the subject. This structure exemplifies the variation given in (16b).

The derivation of (2b), repeated here as (20) and represented below with the tree structure in (21) is also predicted under this analysis.

- (20) a. Sen-in sınav-ı geç-e-me-diğ-in haber-i biz-i üz-dü.
 you-GEN exam-ACC pass-ABIL-NEG-AGR_{NOM} news-CM we-ACC upset-PAST
 ‘The news that you couldn’t pass the exam upset us.’

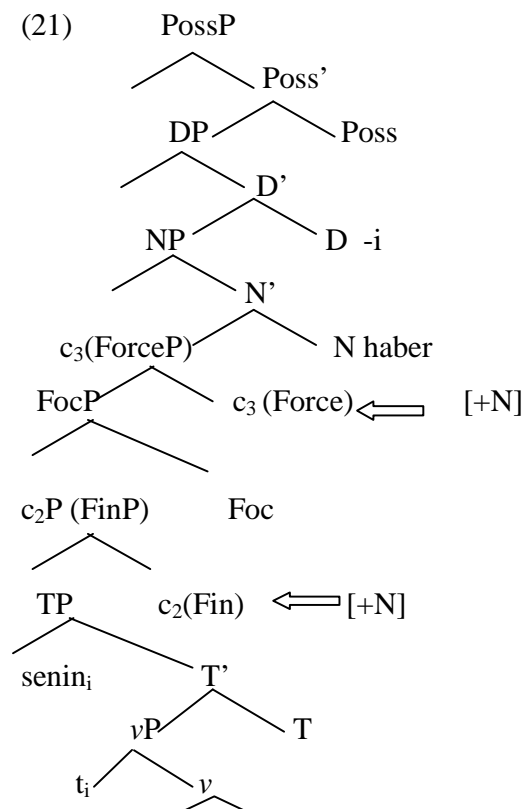

The categorial feature [+N] inserted at phase head c_2 makes the complement domain of this phase nominal. [+N] feature inserted at c_3 extends this nominal domain to the complement of c_3 . Uninterpretable phi features of c_2 percolate down to T head and c_2 -T amalgamate Agrees with the subject in [Spec ν P]. Uninterpretable phi features of the probe are valued as nominal agreement and as a reflex of this c_2 -T values the subject DP's case as Genitive since [+N] feature is inserted at c_3 . This structure exemplifies the variation given in (16a). Now we will turn to the examples of the configurations in (16c-d) which are marginal and restricted some specific constructions and/or speakers.

As discussed in the preceding sections, the derivation of (2c) which is grammatical for Dialect B speakers, repeated here as (22) causes a problem for the analyses which assume different functional projections licensing genitive and nominative case. However under this analysis the structure receives an explanation as represented in the tree structure in (23) below.

(22) Kitab-a hiçkimse-nin bak-ma-mış-tır düşünce-sin-e
 book-DAT anybody-GEN look-NEG-PAST-MOD opinion-CM-DAT

katıl-ıyor-um.

agree-PROG-1SG

'I agree with the opinion that nobody would have looked at the book.'

(23)

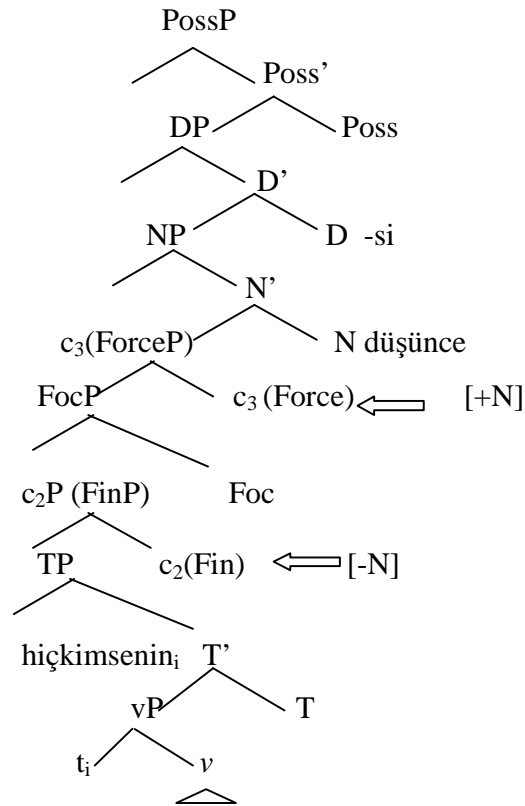

At the phase head c_2 , [-N] feature is inserted thus verbal inflectional morphology appears on the predicate. At the phase head c_3 , on the other hand [+N] feature is inserted. c_2 -T amalgamate probes down and Agrees with the subject DP at [Spec vP]. Uninterpretable phi features of the probe are valued and as the feature inserted at c_2 is [-N], verbal agreement markers appear on the embedded predicate. As a reflex of this feature valuation genitive case is valued on the subject as the feature inserted at c_3 is [+N].

[+/- N] features inserted at phase heads c_2 and c_3 explain Nom/Gen subject case variation in the complement domains of CNPCs in (1a-b) and (1c) for Dialect B.

The structure in (24a) by Schaaik (2002) exemplifies the variation given in (16c).

The subject can also bear Genitive case as illustrated in (24b).

- (24) a. Herşey tamam ol-duğ-u iddia-sı
everything all right be-PRT1-P3S claim-CM
(Schaaik 2002)

- b. Herşey-in tamam ol-duğ-u iddiası
everything-GEN all right be-PRT1-P3S claim-CM
'The claim that everything is all right'

At c_2 [+N] feature is inserted defining this domain as nominal. The uninterpretable phi features of c_2 percolate down to T and c_2 -T Agree with the subject DP in [Spec vP]. Uninterpretable phi features of c_2 -T are valued as nominal agreement and in turn c_2 -T values Nominative case on the subject as [-N] feature is inserted at c_3 .⁴

⁴ As discussed in section 3.1.1, Genitive case in Turkish marks specificity/definiteness if the Genitive DP is not in a generic context as illustrated in (1) below.

- (1) a. Okul-a öğretmen gel-diğ-in-i bil-iyor-um.
school-DAT teacher-NOM come-AGR_{NOM}-ACC know-PROG-1SG
'I know that a teacher came to the school.'

- b. Okul-a öğretmen-in gel-diğ-in-i bil-iyor-um.
school-DAT teacher-GEN come-AGR_{NOM}-ACC know-PROG-1SG
'I know that the teacher came to the school.'

Note that Nom/Gen alternation in CNPCs given in examples (22-24) does not have an effect on specificity/definiteness in that both Nom/Gen subjects have the same interpretation. However these structures are marginal and restricted to some CNPCs.

4.3.3.3 Pseudo Gen/Nom Alternation

Now we turn to the CNPC in (1d-g) repeated below as (25a-d). As discussed in sections 2.4 and 2.5, for Dialect A speakers the Genitive nominal in these structures are not the subjects in the complement clause. There is a *pro* in the embedded clause that may or may not be co-indexed with the Genitive nominal.

(25) a. Sen-in_i [*pro*_{i/j} saatlerce koş-tu-n_{i/j}] iddia-sı sadece bir yalan.

you-GEN for hours run-PAST-2SG claim-CM just a lie

‘The claim (about you) that you ran for hours.’

‘Your claim that ‘you ran for hours’

b. Sen-in_i [*pro*^{*}_{i/j} dün gece bayıl-dı_j] iddia-n_i gerçek değil.

you-GEN yesterday night faint-PAST-3SG claim-2SGPoss true not

‘Your claim that s/he fainted last night is not true.’

*‘Your claim that you fainted last night is not true.’

c. Sen-in_i [*pro*^{*}_{i/j} iflas et-miş-sin_j] haber-in_i biz-i üz-dü.

you-GEN bankruptcy get-PAST-2SG news-2SGPoss we-ACC upset-PAST

‘Your news that ‘you went bankrupt’ upset us.’

* ‘Your news that you went bankrupt upset us.’

d. Sen-in_i [*pro*_{i/j} gizlice evlen-di_{i/j}] söylen-ti-si inandırıcı değil.

you-GEN secretly get married-PAST-3SG rumor-CM convincing not

‘The rumor (about you) that you got married secretly is not convincing.’

‘Your rumor that s/he got married secretly is not convincing.’

These structures are labeled as pseudo Gen/Nom alternation because as opposed to Dialect B speakers who interpret Genitive DP as the subject in some specific CNPCs, for Dialect A speakers Genitive DP is not interpreted as the subject in these clauses. The Genitive nominal is either the genitive possessor as in (25b-c) or part of the elliptical clause as in (25a-d).

The representations for NP-GEN NP-POSS and NP-GEN NP-CM clause structures are repeated below as (26a-b).

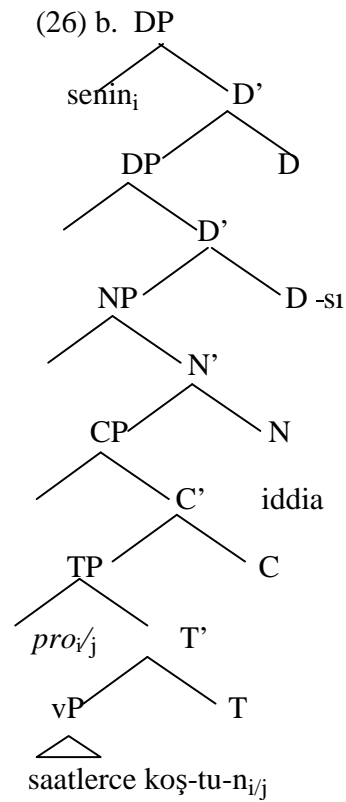
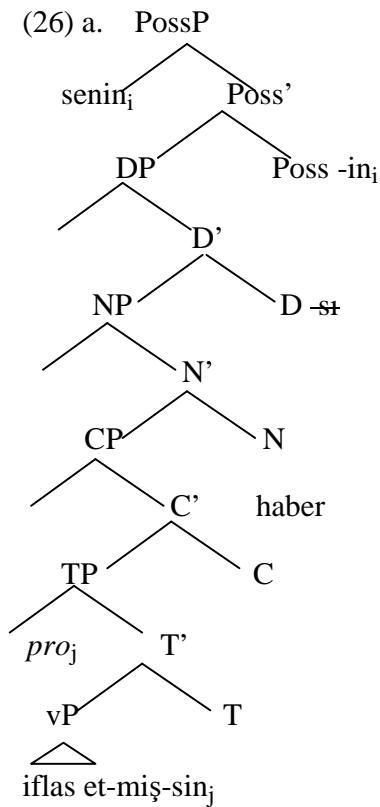

Within the analysis we have made, Nom and Gen subjects remain within the CP domain and do not move to higher projections for case purposes. In those cases in which the Genitive nominal is above the CP domain, it is not the subject as illustrated above in (26a-b) with the tree structures.

Aygen (2002) on the other hand suggests that Gen subject moves to a higher projection than Nom subject and that external nominal head is the Genitive case licenser based on the difference in scope ambiguity with Nom and Gen subjects. The relevant examples are repeated below as (27a-b).

(27) a. [[Pırlanta ya da inci]-nin ucuzlama] ihtimal-i] % sıfır
 Diamond or pearl-GEN get cheaper probability-3agreement 0%

i. ‘The probability that diamonds or pearls become cheap is 0%’ (i.e. neither will become cheaper)

ii. ‘The probability that diamonds become cheap or the probability that pearls become cheap is 0%.’ (i.e. either diamonds or pearls won’t become cheaper)

Probability >[diamond or pearl]; [diamond or pearl] > probability (Aygen 2002: 40)

b. [Pırlanta ya da inci]Ø yüz -de sıfır ihtimal-le ucuzla - yacak.

Diamond or pearl-NOM hundred-loc zero probability-with become cheaper- will

‘Diamonds or pearls will become cheap with the probability of zero %’ (i.e. neither will become cheaper)

Probability >[diamond or pearl]; *[diamond or pearl] > probability (Aygen 2002: 41)

However there is another possibility to explain the scope ambiguity of Genitive subject versus unambiguity of Nominative subject in (27a-b) as already indicated by Aygen (2002).

(27a) is a CNPC and its head noun is base generated at N position above the CP projection with no gap position in the lower domain. (27b) on the other hand is a root clause and the head noun moves from its base generated position to N head.

In order to determine whether structural difference makes a difference in scope interpretation, we applied the same test to CNPCs with Nominative and Genitive subjects.

(28) a. Ahmet ya da Ayşe iş-ten çık-tı söylenti-si doğru değil.
Ahmet-Nom or Ayşe-Nom job-ABL leave-PAST-3SG rumor-CM true not

b. Ahmet ya da Ayşe-nin iş-ten çık-tığ-ı söylenti-si doğru değil.
Ahmet or Ayşe-GEN job-ABL leave-DIK-AGR_N rumor-CM true not

‘The rumor that Ayşe or Ahmet left the job is not true.’

‘The rumor that either Ayşe or Ahmet left the job is not true.’

In both (28a-b) above, it is possible to get ‘either’ reading. Scope ambiguity with Gen subjects have been correlated with the movement of the subject to the higher nominal functional head. Nom subjects on the other hand have been assumed to remain below DP domain. However the structures in (28a-b) illustrate that scope ambiguity is

also possible with Nom subjects in CNPCs. This indicates that ambiguity in Turkish is not related to the position of the genitive or nominative subject.

This is predicted by the framework which takes features instead of positions as making a difference in case licensing. Feature analysis assumes the same case licensing position for Gen/Nom subjects and hence difference in scope ambiguity is not expected.

This section provided a number of arguments in favor of the analysis that Nominative and Genitive subjects remain within the CP projection if they are the subjects of the complement domain. However, it is still not determined whether Nominative and Genitive subjects move to [Spec TP], or Nominative subject remains in its base generated position. The following section provides an answer to this question.

4.4 Movement or Base Generation Analysis

Feature analysis can account for the derivation of CNPCs in Turkish. Gen/Nom subjects are base generated in [Spec vP] and move to [Spec TP]. However it is possible to argue that Gen/Nom subjects remain in-situ and they are not triggered to [Spec TP] position as illustrated in section 4.3.2.

In order to determine the position of Nom/Gen subjects, the lexical item insertion test has been applied which has been adopted from Harada (1971) and Miyagawa (2009). Miyagawa (2009) uses this test to determine the size of the clauses with Gen/Nom subjects.

When the subject appears to the left of an intervening element like an adverb, it is assumed to have moved out of its base generated position. If insertion of lexical items to

the right of the subject yields ungrammaticality, then the subject is still in its base generated position and it is forced to move.

Miyagawa (2009) convincingly shows that in Japanese Gen subject constructions, C projection is missing and T head cannot attract the subject DP to its specifier position. Gen subject constructions are judged to be degraded in grammaticality when the Gen subject appears to the left of the inserted lexical item because then Gen moves out of ν P projection without a trigger. In contrast to Gen subjects, Nominative subject constructions are grammatical when they appear to the left of the lexical item indicating that movement of Nom subject to [Spec TP] is triggered by the Edge Feature inherited from C.

The same test can indicate to us the position of Nom/Gen subjects and the size of the clause. If the subject remains in-situ, then the subject cannot appear to the left of an intervening element like an adverb. If the subject appears to the left of the intervening element then this indicates that the subject has moved out of ν P position.

- (29) a. Ahmet gizlice para-yı çal-mış dedikodu-su
 Ahmet-NOM secretly money-ACC steal-PAST-3SG rumor-CM
- herkes tarafın-dan konuş-ul-uyor.
 everybody by-ABL speak-PASS-PROG.

b. Ahmet-in gizlice para-yı çal-dıĝ-ı dedikodu-su
 Ahmet-GEN secretly money-ACC steal-DIK-AGR_{NOM} rumor-CM
 herkes tarafın-dan konuş-ul-uyor.
 everybody by-ABL speak-PASS-PROG.

‘The rumor that Ahmet stole the money secretly is talked by everybody.’

Note that both (29a-b) are grammatical. Assuming that the adjunct ‘*gizlice*’ is merged to ν P projection and the fact that Gen/Nom subjects appear to the left of the adjunct indicate us that the subject has moved out of ν P projection.

As illustrated in (30) below, even when there is more than one intervening elements to the right of the Nom/Gen subjects the structures are not ungrammatical.

(30) a. Çocuk-lar hep birlikte iřtahla kek-i ye-di-ler
 children-PL-NOM altogether heartily cake-ACC eat-PAST-3PL
 iddia-sı asılsız-mıř.
 claim-CM ungrounded-PAST

b. Çocuk-lar-ın hep birlikte iřtahla kek-i ye-dik-ler-i
 Children-PL-GEN altogether heartily cake-ACC eat-DIK-AGR_{NOM}-ACC
 iddiası asılsızmıř.
 claim-CM ungrounded-PAST

‘The claim that the children altogether ate the cake heartily was groundless.’

In both (30a-b) there appear two intervening elements *'hep birlikte'* and *'iştahla'* to the right of the Nom/Gen subjects. The sentences are fully grammatical indicating that movement of both Nom and Gen subjects are triggered by a higher functional projection.

This line of analysis predicts ungrammaticality when the Gen/Nom subject is to the right of the adverb indicating that the movement of the subject to a higher functional projection has not been triggered.

- (31) a. Gizlice Ahmet parayı çalmış söylentisi
secretly Ahmet-NOM money-ACC steal-PAST-3SG rumor-CM

herkes tarafından konuşuluyor.
everybody by-ABL speak-PASS-PROG.

'The rumor that Ahmet stole the money secretly is talked by everybody.'

The grammaticality of this structure indicates that adverb test is not a conclusive one in Turkish as the nominative subject can appear to the right or left of the adverb which marks *vP* boundary. This can be explained in terms of Lebeaux's (1988, 1991) proposal regarding late insertion of adjuncts. In order to find out the target position of the Nom/Gen subjects in Turkish we will focus on some further conclusive tests in sections 5.3.1.2 and 5.3.1.3.

4.5 Turkish Complement and Adjunct Clauses

This section re-examines Nominative/Genitive case licensing in complement and adjunct clauses and relative clauses within the analysis of Features as Case Licenser and show that Features as Case Licenser Approach can account for case alternation in these constructions as well.

4.5.1 Complement Clauses

As has been noted in chapter three, the presence of Genitive case in complement clauses depend on the presence of the nominalizers –DIK, -mA,-(y)AcAK. These are exemplified in (32a-c).

- (32) a. Sen-in kitap-ı oku-duğ-un-u bil-iyor-du-m
 you-GEN book-ACC read-AGR_{NOM}-ACC know-PROG-PAST-1SG
 ‘I knew that you read the book.’
- b. Sen-in bu şarkı-yı söyle-me-n-i isti-yor-um.
 you-GEN this song-ACC sing-AGR_{NOM}-ACC want-PROG-1SG
 ‘I want you to sing this song.’
- c. Sen-in dışarı-ya çık-acağ-ın-ı san-dı-m.
 you-GEN outside-DAT go out-AGR_{NOM}-ACC think-PAST-1SG
 ‘I thought that you would go out.’

As illustrated in the examples, in complement clauses with the nominalizers only genitive case is licensed. This indicates that the categorial feature inserted at c_3 is [+N].

The derivation of these complement clauses is given below in (33)

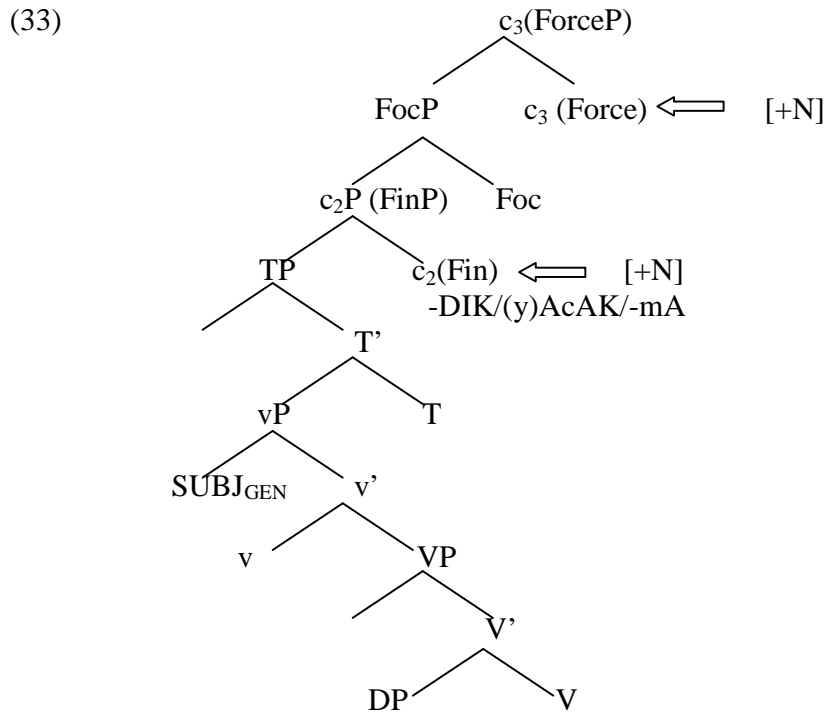

At the phase head c_2 [+N] feature is inserted defining the complement domain of this phase as nominal. At the phase head c_3 [+N] feature is inserted which not only determines its complement domain as nominal but also determines the subject case that is to be licensed by c_2 -T amalgamation as Genitive. c_2 transmits its uninterpretable phi features to T head and c_2 -T amalgamate Agrees with the goal in [Spec v P]. The uninterpretable phi features of the c_2 -T amalgamate are valued as nominal agreement on the embedded predicate and the case of the subject is valued as genitive.

The derivation of complement clause without a nominalizer given in (34) with nominative subject on the other hand is illustrated with the tree structure in (35).

(34) Sen okul-da-ki toplantı-ya git-ti-n sandım.
 you-NOM school-LOC- REL meeting- DAT go-PAST-2SG think-PAST-1SG

‘I thought that you went to the meeting at the school.’

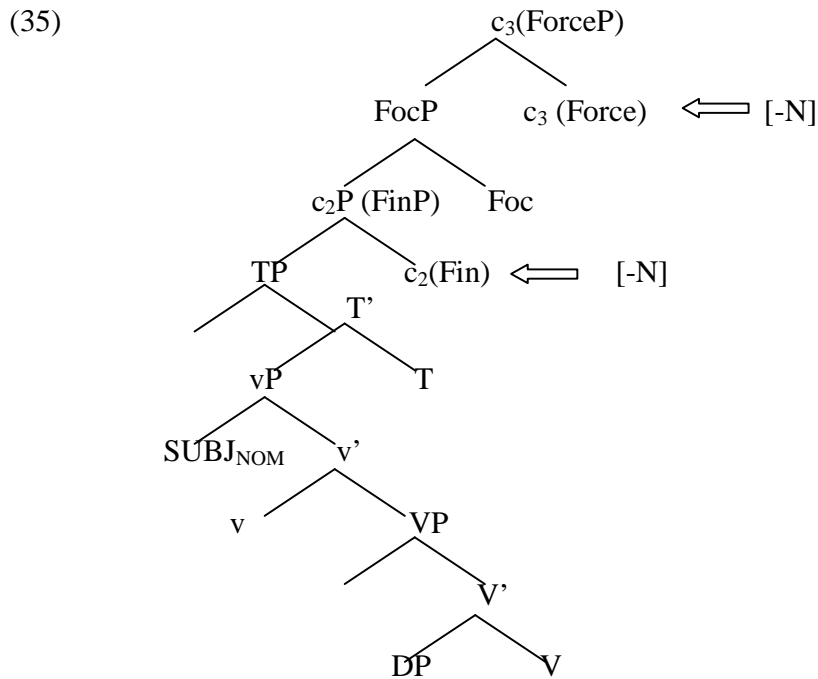

c_2 and c_3 get [-N] features at Transfer and this determines the complement domain of these phase heads as verbal. This is indicated by the verbal inflectional morphology on the embedded predicate. c_2 -T Agrees with the goal in [Spec vP], their uninterpretable phi features are valued and as a reflex of this c_2 -T values Nominative case on the subject.

These data show that this approach predicts Nom/Gen case licensing in complement clauses. Note that Genitive case is licensed in complement clauses of verb heads given in (32a-c) and complement clauses of nouns, only when at c_2 [+N] feature is inserted. If the complement domain of c_2 is defined as verbal with the insertion of [-N]

feature then Genitive case is not licensed. This precondition for Turkish is stated in (36) below:

(36)

- a) c_2 : [+N]
- b) Agree (c_2 -T, g) [Internal relation]
- c) Select (c_3 , c_2 -T)
- d) Select (x(verbal/nominal head), c_3) [External relation]
- e) value (c_2 -T \rightarrow g uninterpretable case genitive)

According to this formulation, at c_2 [+N] feature is inserted which defines the complement domain as nominal. Nominalizers –DIK/-(y)AcAK, -mA occupy this position. However this is not enough for genitive case licensing and c_2 -T system combining with c_3 must become an argument of a verbal or nominal head.

Although with this formulation the appearance of Genitive subject in complement clauses of verbal or nominal heads with nominalizers on the embedded predicates is predicted, we need an additional rule for Dialect B structures exemplified in (22) and the structure in (24) which are marginal and restricted to some specific CNPCs.

Note that Nom/Gen alternation is possible only with complement clauses of nominal heads namely in certain CNPCs so we come up with the following exceptions to the generalized rule given below in (37-38).⁵

(37) $c_2 [-N] c_3 [+N]$

- a) $c_2: [-N]$
- b) Agree (c_2-T, g) [Internal relation]
- c) Select (c_3, c_2-T)
- d) Select ($x(\text{nominal head}), c_3$) [External relation]
- e) value ($c_2-T \rightarrow g$ uninterpretable case genitive/nominative)

(38) $c_2 [+N] c_3 [-N]$

- a) $c_2: [+N]$
- b) Agree (c_2-T, g) [Internal relation]
- c) Select (c_3, c_2-T)
- d) Select ($x(\text{nominal head}), c_3$) [External relation]
- f) value ($c_2-T \rightarrow g$ uninterpretable case genitive/nominative)

When at $c_2 [-N]$ feature is inserted and if c_3 is selected by a nominal head, $[+/-N]$ feature insertion at c_3 makes Gen or Nom case alternation possible as given in (16d). When at c_2

⁵ In existential clauses, definite subjects yield ungrammaticality (Milsark 1974). In existential clauses the subject must be indefinite/non-specific and in Turkish Nominative case is expected on the subject as (1) indicates (Aygen 2002).

(1) Sokak-ta çocuk(*un) ol-duğ-u iddiası
street-DAT child-NOM be-PRT1-P3S claim-CM
'the claim that there are children on the street'

Genitive case has specific/definite reading. (See section 3.1.1) and hence Genitive case in (1) yields ungrammaticality and this structure is not an exception to the pre-conditions given in (36) above for Genitive case licensing.

[+N] feature is inserted and if c_3 is selected by a nominal head [+/-N] feature insertion at c_3 makes Gen/Nom alternation possible as in (16c).

Nom/Gen case alternation is possible only in the complements of nominal heads but this alternation is not licensed with complements of verbal heads which explains the ungrammaticality of the following structure.

- (39) *Ben senin okul-da-ki toplantı-ya
 I-NOM you-GEN school-LOC- REL meeting- DAT
- git- ti-n sandım.
 go-PAST-2SG think-PAST-1SG
- ‘I thought that you went to the meeting at the school.’

At c_2 [-N] feature is inserted which defines this domain as verbal. c_3 is the complement of a verbal head so genitive case cannot be licensed within the assumptions of the rules given above.

For Dialect A speakers, Gen/Nom alternation is not possible and the genitive nominals in (25a-d) are either genitive possessors or part of an elliptical clause and hence they are analyzed as ‘pseudo Nom/Gen’ alternation. For Dialect B speakers on the other hand although marginal Gen/Nom alternation is possible and the preconditions given in (37) predict this alternation.

The next section takes a look at adjunct clauses.

4.5.2 Adjunct Clauses

Adjunct clauses with nominalizers –DIK/(y)AcAK and –mA differ with respect to the case on the subject as the examples given in (40a-d) illustrate.

- (40) a. [[Ben alışveriş yap-tığ-ım] için] yorul-du-m.
I-NOM shopping do-AGR_{NOM} as get tired- PAST-1SG
'I got tired as I did shopping.'
- b. [[Ayşe-nin Ankara-ya git-me-si] için] bilet al-dı-k.
Ayşe-GEN Ankara-DAT go-AGR_{NOM} for ticket-NOM buy-PAST-1PL
'We bought a ticket for Ayşe to go to Ankara.'
- c. [[Hasan-ın duy-duğ-un-a] gore] herkes duy-acak-mış.
Hasan -GEN hear-DIK- AGR_{NOM}-DAT according to everybody hear-FUT-REP
'According to what Hasan heard, everybody will hear (it)' (Aygen 2007, 17)
- d. [[Hasan duy-duğ-un-a] gore] herkes duy-acak.
Hasan -NOM hear-DIK- AGR_{NOM}-DAT since everybody hear-FUT
'Given that/since Hasan heard, everybody will hear (it)' (Aygen 2007, 18)

In (40a-d) the adjunct clause with the nominalizer –DIK appears with a nominative subject. In (40b) on the other hand the adjunct clause with the nominalizer –mA has a subject marked with genitive case.

Note that in (40d) the subject is marked with nominative case in contrast to (40c) although they are both adjunct clauses with the nominalizer –DIK.

Aygen (2007) holds that the difference between the two adjunct clauses stems from the properties of ‘*göre*’. It is a postpositional phrase in (40c) and it is a complementizer in (40d).⁶

Under the current framework the structure of adjunct clauses is analyzed in the following way. We assume that the structures with nominative and genitive subject clauses have different representations in (40a-b) and (40c-d). In (40a) ‘*için*’ is a complementizer while in (40b) it is a postpositional phrase. We base our arguments on the following contrasting properties of these clauses. It is possible to insert a nominal head in genitive subject clauses while this is not possible with nominative subject clauses as indicated in (41a-b).

⁶ As discussed in detail in section 3.2.3.2, Aygen (2002) suggests that interrogative subordinate clauses are Relative clauses based on co-ordination and gap filling tests, and declarative subordinate clauses are Complex Noun Phrase Constructions based on head insertion test. As illustrated in the following examples –DIK adjunct clause given in (40c) allows insertion of a head noun as in (1a) which means that the outer layer is not a CP.

(1) a. [_{PP} [_{NP} [Hasan-ın duy-duğ-u] şey-e] göre] herkes duy-acak-mış
 Hasan -GEN hear-DIK-agr thing-Dat based on everybody hear-fut-rep
 ‘Based on/according to what Hasan heard, everybody will hear (it).’

b. *[[Hasan-ın haber-i anla-dığ-ın]a göre] üç kişi gel-ecek.
 Hasan -GEN news-acc understand-DIK-agr-Dat based on 3 person come-fut
 ‘*Based on what Hasan understood the news, three people are going to come.’ (Aygen 2002, 20, 22)

However as seen in the ungrammaticality of (1b), the same clause does not allow an object insertion which means that the same structure can be analyzed as a Relative clause within a postpositional phrase.

(41) a. Ayşe-nin Ankara-ya git-me amacı için/ gitmesi amacı-yla
 Ayşe-GEN Ankara-DAT go-mA purpose for/ go-AGR_{NOM} purpose-with
 bilet al-dı-k.
 ticket-NOM buy-PAST-1PL
 ‘We bought a ticket for Ayşe’s purpose to go to Ankara/with the purpose that
 Ayşe goes to Ankara.’

b. *Ben alışveriş yap-tığ-ım nedeni için/nedeniyle yorul-du-m.
 I-NOM shopping do-AGR_{NOM} reason since/because of get tired-PAST-1SG
 Intended reading: ‘I got tired because of the reason that I did shopping.’

While (41a) allows insertion of a noun, this yields to ungrammaticality in (41b) indicating that (41b) is a CP projection while (41a) is not and hence we suggest that ‘*için*’ in (41a) is a postpositional phrase.

The following example supports the argument that ‘*için*’ is a postpositional phrase in genitive subject clauses. Göksel and Kerslake (2005) point out that, postpositional phrases have an adjectival function as illustrated in (42a).

(42) a. sen-in kadar bir çocuk
 ‘a child of the same age/size as you’

(Göksel & Kerslake 2005, 99)

b. Ayşe-nin Ankara-ya git-me-me-si için bir engel/sebep
 Ayşe-GEN Ankara-DAT go-NEG-AGR_{NOM} for one difficulty/reason
 ‘A difficulty/reason for Ayşe to not to go to Ankara’

- c. *Ben alışveriş yap-tığ-ım için bir neden/sorun
 I-NOM shopping do-AGR_{NOM} since one reason/problem
 ‘a reason/problem since I did shopping’

In a similar vein, adjunct clause with genitive subject in (42b) can have an adjectival function but this is not allowed in (42c).

Now we turn to the derivation of the adjunct –mA clause in (43b) given below:

(43)

(40b) Ayşe-nin Ankara-ya git-me-si için bilet al-dı-k

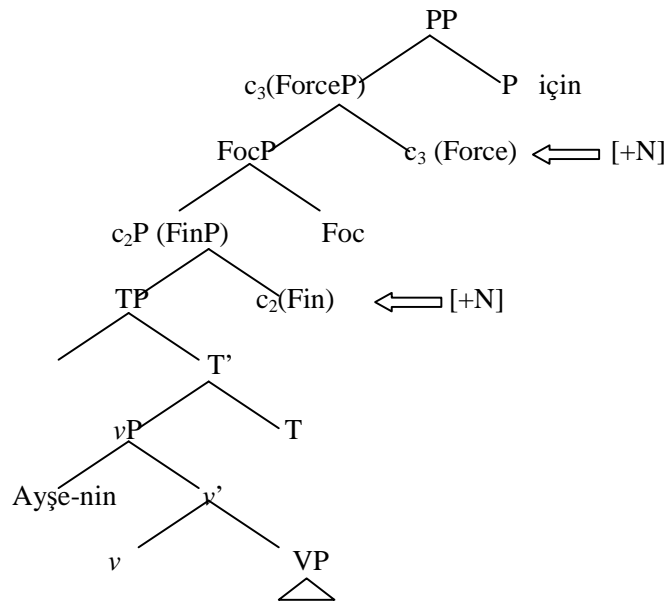

At the phase heads c_2 and c_3 [+N] feature is inserted determining the category of the complement of the phase heads as nominal. c_2 transmits its uninterpretable phi features

to T head. c_2 -T amalgamate Agrees with the goal, gets the uninterpretable phi features valued and in return values Genitive case on the subject as [+N] is inserted at c_3 .

The tree structure of the adjunct –DIK clauses with genitive subject is illustrated below.

(44)

(40c) Hasan-ın duy-duğ-un-a göre herkes duy-acak

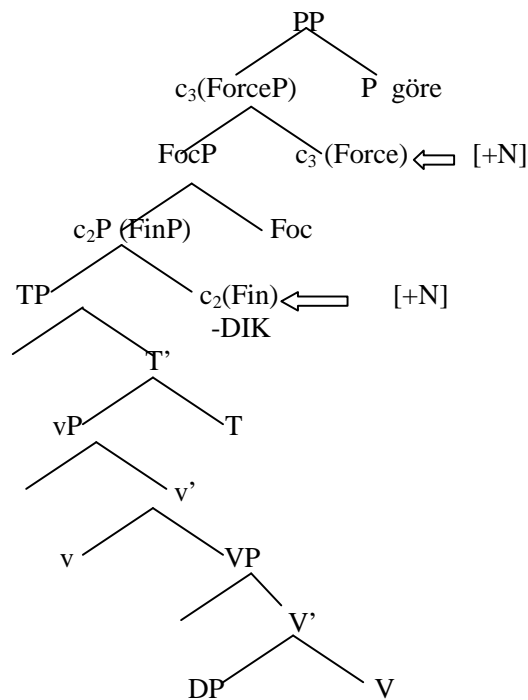

At c_2 [+N] feature is inserted defining the complement domain of this phase head as nominal. At c_3 [+N] feature is inserted. c_2 -T amalgamation agrees with the subject and their uninterpretable phi features are valued and in turn c_2 -T values the subject case as genitive as [+N] feature is inserted at c_3 .

As for –DIK adjunct clauses with Nominative subjects illustrated in (40a) and (40d), we assume that overt complementizers ‘için’ and ‘göre’ occupying C position

block Genitive case licensing and hence Nominative case appears on the subjects. Note that both adjunct clauses bear nominal agreement markers indicating [+N] feature inserted at c_2 . If adjunct clauses are complements of postpositional phrases then [+N] insertion at c_3 makes Genitive case licensing possible, however the appearance of an overt complementizer blocks Genitive case valuation. This is stated in (45) below.

(45)

- a) c_2 : [+N]
- b) Select (c_2 -T) [Internal relation]
- c) Select (c_3 , c_2 -T)
- d) Agree (x (PostP), c_3) [External relation]
- f) value (c_2 -T \rightarrow g uninterpretable case genitive)

Note that this precondition predicts Genitive case licensing in $-mA$ and $-DIK$ adjunct clauses which are selected by a postpositional phrase and Nominative case licensing in $-DIK$ adjunct clauses with an overt complementizer.

4.5.3 Relative Clauses

As illustrated in section 3.1.3.1, Genitive subject is also observed in $-DIK$ type of relative clauses which are referred to as non- subject relative (NSR) clause form.

- (46) [Dün ben-im Ø_i bahçe-de gör-düğ-üm] çocuk_i bugün
 yesterday I-GEN garden-LOC see-DIK-1SG child-NOM today
 görün-mü- yor.
 appear-NEG-PROG

‘The child that I saw yesterday in the garden does not appear today.’

As is the case with noun-complement clauses, -DIK type of Relative clause appears with an external head which is co-indexed with the empty category in the relativized clause.

Kornfilt (2003) argues that noun-complement clauses and relative clauses are not the same and Relative clauses are adjuncts of the external heads with the following test.

- (47) a. Ali-nin geçen gün dükkan-dan al-dığ-ı bu şahane vazo
 Ali-GEN past day shop-ABL buy-FN-3SG this magnificent vase
 ‘This magnificent vase which Ali bought at the store the other day’
- b. *[Ali-nin_i [pro_i aile- sin] i terket- tiğ-i] şu söylenti-si
 Ali-Gen family-3.SG-ACC abandon- FN-3.SG that rumor-CMPM
 Intended reading: ‘that rumor that Ali abandoned his family.’

While a relative clause allows insertion of a lexical item before the head noun, it is not possible with the noun-complement clause as the ungrammaticality of (47b) suggests. However as illustrated in section 3.2.3.1, relative clauses show a predicational

relation with the head noun indicating that they are not fully grammaticalized. Thus the following rule given in (48) predicts the derivation of relative clauses with genitive subject.⁷

(48)

- a) c₂: [+N]
- b) Select (c₂-T) [Internal relation]
- c) Select (c₃, c₂-T)
- d) Indexation (x nominal head),c₃ [External relation]
- e) value (c₂-T→g uninterpretable case genitive)

Within the assumptions given below the derivation of the relative clause given in (46) takes the following steps. At c₂ [+N] feature is inserted defining the complement domain as nominal. Through indexation c₃ agrees with the external nominal head making genitive case licensing possible. c₂-T agrees with the subject in [Spec vP] and the

⁷ In Turkish -DIK type of Relative Clauses, the embedded predicate bears nominal agreement markers and the subject bears genitive case marker indicating that the features inserted at phase heads c₂ and c₃ are [+N]. However in some other Turkic languages like Kazakh, Tuvan and Dagur the agreement markers do not appear on the embedded predicate but on the head noun which indicates different case licensing mechanisms for these Turkic languages.

Kazakh

(1) a. Men- Ø [Ali-nin aynek-ti sindir-gan] waqit-in]in bil-ip-jatre-di-m
 I-Nom -GEN glass-acc break-perf time-agr-acc know-conv-aux-past-1sg
 'I knew when Ali broke the glass'
 [[S-GEN Obj-acc V-Perf] Noun-agr]acc.....

Tuvan

b. Men- Ø [Ali-nij ket-ip qal-gan waqit-in-]ni bil-ip tur e-di-m
 I- NOM -GEN go-conv aux-perf time-agr-acc know-conv prog-past-1s p
 'I knew when Ali went'
 [[S-GEN V- aux-Perf] Noun-agreement]acc..... (Hale 2002)

uninterpretable phi features of the amalgamate are valued. As the features inserted at c_2 is [+N] nominal inflectional morphology appears on the embedded predicate. At c_3 [+N] is inserted so c_2 -T amalgamation licenses Genitive case on the subject.⁸

4.6 Summary

This chapter has focused on the syntactic derivations of CNPCs for Dialect A and B. On the basis of Hiraiwa's (2005) Supercategorial Theory of CP/DP parallelism, case licensing mechanism in CNPCs has been analyzed as features [-/+N] inserted at phase heads c_2 and c_3 . This analysis has been further extended to complement clauses, adjunct clauses and –DIK type of Relative clauses in Turkish.

⁸ Relative Clauses are similar to CNPCs in that there is an external nominal head, however in CNPCs both [+/-N] feature insertion at phase heads c_2 and c_3 are possible while in Relative Clauses only [+N] feature inserted at c_2 and c_3 derives the grammatical –DIK type of Relative Clause. However as noted by Yumrutaş (2009) and Öztürk (p.c), children can form the following Relative Clauses in (1 a-2a) which are possible within the model but ungrammatical in Turkish.

- (1) a. *kadın tekmele-diğ-i adam
 woman-NOM kick-NSP-3rdsgPOSS man
 Intended Meaning
 b. kadın-in tekmele-diğ-i adam
 woman-GEN kick-NSPP-3rdsgPOSS man
 ‘The man whom the woman is kicking’ (Yumrutaş 2009, 20)
- (2) a. *çocuk oku-du kitap
 Child-NOM read-PAST-3SG book
 Intended Meaning
 b. çocuğ-un oku-duğ-u kitap
 child-GEN read-DIK-AGR_{NOM} book
 ‘The book which the child is reading’

When c_3 has a predicational relation with the external nominal head only [+N] insertion at c_2 and c_3 yields grammaticality. This issue requires further investigation.

The analysis of the CNPCs has captured the observation that Genitive subject is not within the CP projection in Pseudo Nom/Gen alternation construction for Dialect A but it is the subject in the embedded clause in some CNPCs for Dialect B.

CHAPTER FIVE

EPP, CASE CHECKING AND SUBJECT POSITIONS

5.1 Introduction

EPP has been revised in many ways since it was first proposed by Chomsky (1982) as a requirement that all clauses have a subject. EPP formulations have taken the following steps from GB to the MP.

- EPP is a requirement that all clauses should have a subject (Chomsky 1981,1982) The obligatory presence of expletives in (1a) or the movement of the arguments to matrix [Spec IP] in raising constructions in (1b) has been taken to be EPP triggered. EPP has also been suggested for the movement of the arguments to intermediate [Spec IP] as illustrated in (1c).

(1) a. It seems that the student is in the class.

b. There seems to be a student in the class.

[_{Spec IP} there [_{IP} seems [_{Spec IP} ~~there~~ [_{IP} to be [_{SC}[a student] [in the class]]]]]]

c. The students seem all to have done their homework.

In (1a) the subject in the embedded clause is in a case licensing position with its theta role assigned and has no trigger to move to the matrix [Spec IP]. Thus an expletive is inserted into [Spec IP] for EPP purposes. In (1b) the expletive ‘*there*’ moves from

embedded [Spec IP] to matrix [Spec IP] in order to satisfy EPP. In (1c) subject quantifier ‘*all*’ appears in the embedded clause while the subject is in matrix [Spec IP]. Then the movement of the subject is from [Spec VP] to embedded [Spec IP] to matrix [Spec IP]. Embedded IP isn’t a proper case assigner thus movement to this position from [Spec VP] can only be triggered by EPP.

- EPP is a requirement that D feature of Infl should be checked overtly (Chomsky 1995)

When Chomsky (1995) suggested feature checking mechanism for movement operations, EPP has been revised as a strong feature which should be checked overtly.

(2) [_{TP} John_i [_{vP} t_i [_{VP} saw Mary]]]

According to this formulation of EPP, the structure in (2) has the following derivational steps. As a probe, T head with uninterpretable phi features searches for a goal with matching features within its c-command domain. The probe Agrees with the DP in [Spec vP] and its uninterpretable phi features are deleted and the probe values the goal’s case as nominative. Then the goal is attracted to the specifier position to satisfy strong EPP requirement.

- EPP is a requirement that the specifier position should be filled overtly (Chomsky 1999, 2000).

With new specifications on the nature of T head, EPP has been revised in the following way. If T has a complete phi set it can project a Spec position which has to be filled overtly otherwise T with a defective phi set cannot project Spec position. With this re-

formulation intermediary EPP effects in raising constructions as in (3a-b) and ECM constructions have been dispensed with, as T is with a defective phi set in these constructions.

(3) a. There are likely to be awarded several prizes.

b. Several prizes are likely to be awarded.

In (3a-b) embedded T is defective as it is not phi complete. T_{def} cannot have an EPP feature thus the expletives in (3a) does not move from embedded [Spec TP] to matrix [Spec TP] but it is inserted in matrix [Spec TP] and the movement of the object DP in (3b) is from its base generated position to matrix [Spec TP]. Intermediary EPP effect is eliminated.

- EPP is a feature inheritance (Chomsky 2008)

With this formulation EPP is revised as feature inheritance. T inherits Edge Feature (EF) from C together with Agree feature. That is why a DP is raised to [Spec TP] or an expletive is merged. Case and phi features of the probe C-T are checked through Agree operation which renders movement of the goal to [Spec TP] solely for EPP purposes.

Whether EPP is an independent universal principle or not has been questioned a lot in the literature. Some take EPP as a syntactic mechanism independent of Case and Agreement (Lasnik 2003). Still another line of analysis claims that EPP effects can be explained through some other well-grounded syntactic mechanisms like Case, Locality Conditions on Movement (Boškovič 2007), phi feature agreement (Alexiadou and Anagnostopoulou 1998) while some others argue that EPP should be eliminated from

the theory without appealing to any other mechanism (Grohmann, Drury and Castillo 2000).

The main concern of this chapter is to find out the status of EPP in Turkish, whether EPP exists as an independent syntactic mechanism or overlaps with other syntactic mechanisms like Case/Agree. The discussion will have implications for the universality of EPP within the generative framework. Movement operations of the subjects are crucial in understanding the nature of EPP so we will apply some tests to determine the target position of the Genitive and Nominative subjects in Turkish.

Section 5.2 takes a look at the status of EPP with respect to other syntactic mechanisms and EPP in null subject languages. Section 5.3 provides a number of tests which illustrate the target positions of the subject and section 5.4 discusses the status of EPP in Turkish based on the conclusions reached in the preceding sections.

5.2 EPP as a Universal Principle

EPP has been under discussion both as an independent syntactic mechanism and also from a cross linguistic perspective. Section 5.2.1 presents arguments against EPP which reveals overlaps with already existing syntactic mechanisms. Section 5.2.2 takes a cross linguistic perspective on EPP and illustrates how Null Subject languages account for EPP and subject positions.

5.2.1 Dispensing with EPP through other Syntactic Mechanisms

EPP was stated as a requirement that every clause have a subject (Chomsky 1981, 1982). The main motivation for the principle came from the need to explain the obligatory presence of expletives in languages.

Examples such as the following have been argued to present evidence in favor of the proposal that the existence of the expletive in [Spec TP] is not for Case or Agree purposes but for EPP feature.

(4) a. [C [T be likely [Expl to-arrive a man]]]

b. There is likely to arrive a man. (Chomsky, 2001)

The structure in (4) is a raising construction with an unaccusative and the Expletive is in the same sub-numeration with the unaccusative predicate. Expletive is merged to embedded [Spec TP] for EPP purposes. Matrix T also has an EPP feature and probes the Expletive as the closest element and triggers it to move to [Spec TP] to delete its EPP feature. Uninterpretable phi features of T are not deleted. T Agrees with the goal '*man*' thereby deleting its uninterpretable phi features and in turn valuing the case feature of the goal as Nominative.

The movement of the expletive to [Spec TP] does not give rise to any redundancy given that the movement is not for Case or Agree purposes. Uninterpretable phi features of T head are valued through Long Distance Agree with the DP '*a man*' which remains in its merge position.

However, there are some structures in which the movement of the subject to [Spec TP] is redundant as the same movement can be analyzed to be triggered by Case, Agreement, Locality Conditions on Movement or Theta theory. The relevant examples are illustrated below.

(5) a. Lina was kissed *t* (by Leo).

b. Kai was believed [*t* to have won the soccer match.]

c. The birdcage was found [*t* empty].

(6) a. Lina seems [*t* to like her brother].

b. Lina is likely [*t* to fall asleep].

(7) a. Jeffrey's bus arrived *t*.

b. The tree fell *t*. (Bobaljik and Wurmbrand, 2005)

(8) a. Someone_{*i*} is likely [IP *t_i* to be *t_i* in the garden].

b. * [IP [VP [Kissed John]]] (Bošković 2007)

The examples in (5a-c) are passive constructions, (6a-b) are raising constructions and (7a-b) are unaccusatives. EPP requires [Spec TP] to be filled overtly; hence EPP triggers the movement of the arguments.

Note that the same movement can be analyzed by appealing to Case licensing. There is not a proper case licensing functional head in the base generated positions in (5-7) and hence the arguments move to another position where they are licensed case. Thus

both EPP and Case can be taken as the trigger of the movement. This overlap yields a redundancy in the system.

In (8a), the movement of the subject from intermediate [Spec TP] to matrix [Spec TP] can be analyzed both as an EPP driven movement or locality conditions on movement. Either the subject is triggered to move to embedded [Spec TP] by EPP feature of T or the subject moves to [Spec TP] because movement to matrix TP must proceed successive cyclically. For similar structures Epstein and Seely (2006) argue that the movement of the subject occurs in one fell swoop to the matrix [Spec TP] where the subject checks its case.

We get a similar redundancy in (8b) as well. The ungrammaticality of the structure can be due to unsatisfied EPP feature of T. Another possibility to explain the ungrammaticality of (8b) is to suggest that Theta Criterion is violated as the predicate has not assigned its agent theta role. Boškovič (2007) also explains EPP effects in (8b) through Case by assuming that case must be checked overtly and Inverse Case Filter applies namely case assigners have to assign their case. By using already existing syntactic mechanisms EPP can be dispensed with.

As clearly indicated by the examples given above, having independent syntactic mechanisms with the same movement effect yields redundancy. Thus EPP as an overlapping feature with the other syntactic mechanisms has been questioned by many researches (Grohmann, Drury and Castillo 2000, Epstein and Seely 2006, Boškovič 2007). By attributing the movement operations to already existing syntactic mechanisms like Case/Agreement, Locality Conditions on Movement, Theta Theory, the exact nature

of EPP has been tried to be captured. As Epstein and Seely (2006) note ‘attempting to eliminate the EPP will, at best, allow us to deduce the ‘EPP’s’ properties and effects from independently motivated principles.’

5.2.2 EPP in Null-Subject Languages

EPP has been under discussion not only for the redundancies for the system but also because in some null subject languages EPP effects have not been observed. Alexiadou and Anagnostopoulou (1998) argue that EPP is parameterized across languages. In some languages like English, EPP is satisfied through move/merge DP strategy, while in some other languages like Spanish and Greek, it is satisfied through move/merge V strategy.

Alexiadou and Anagnostopoulou (1998) suggest that in languages which employ move/merge X strategy, EPP feature of T is satisfied through the agreement markers on the predicate which have a pronominal status.

In a similar vein, Öztürk (1999, 2001) argues that in Turkish, EPP feature of T is satisfied through V to T movement. She therefore holds that [Spec TP] is not always projected. Öztürk bases her arguments on the evidence presented by the distribution of overt pronouns and referential expressions. In contrast to the arguments that Turkish is a *pro*-drop language (Kornfilt 1984, Enç 1986, Özsoy 1987), Öztürk (1999, 2001) suggests that the distribution of overt pronouns in contrast to *pro* is discourse dependent. Overt pronouns signal a topic change in discourse as illustrated in the following examples.

(9) a. Ben_i ev-e gel-di-m. pro_i kitap oku-du-m. pro_i televizyon seyret-ti-m.
I house-dat come-past-1p.sg. book read-past-1p.sg TV watch-past-1p.sg

b. Ben_i ev-e gel-di-m. *Ben kitap oku-du-m. *Ben televizyon seyret-ti-m.
I house-dat come-past-1p.sg. I book read-past-1p.sg I TV watch-past-1p.sg
'I came home. I did some reading. I watched TV.'

c. Ben_i ev-e gel-di-m. pro_i kitap oku-du-m. pro_i televizyon seyret-ti-m.
I house-dat come-past-1p.sg. book read-past-1p.sg TV watch-past-1p.sg

Sen ara-dı-n.
You call-past-2p.sg
'I came home. I did some reading. I watched TV. You called (me).'

(Öztürk 1999, 4)

In (9a) the presence of the overt pronoun in the first sentence is sufficient as there is not a topic shift. In the absence of a topic shift, the repetition of an overt pronoun yields ungrammaticality as shown in (9b). The grammaticality of (9c) on the other hand indicates that the presence of an overt pronoun is obligatory when there is a topic shift.

For the examples in (9), Öztürk (1999) suggests the following tree structure in
(10)

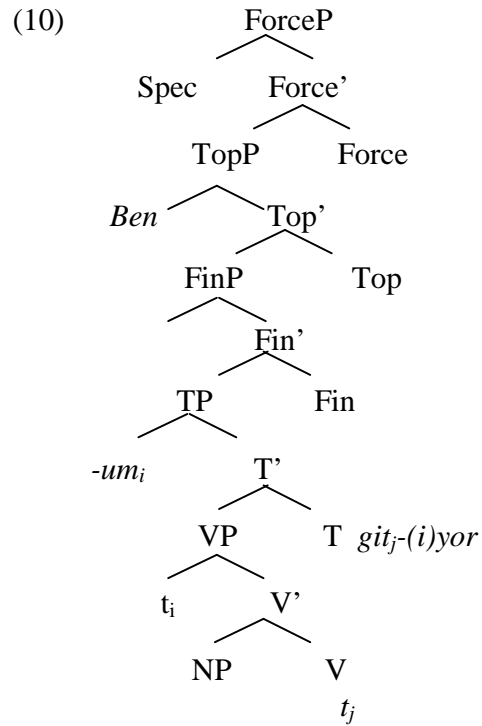

The overt pronoun is base generated in [Spec TopP]. Given that the overt pronoun is co-referential with the agreement marker on the predicate, Öztürk (1999) suggests that agreement markers base generated in [Spec VP] move to [Spec TP]. FinP copies the agreement features and moves to Top head. The new amalgamate head Fin-Top makes it possible for the pronoun to be co-indexed with the subject.

Öztürk (1999) extends her analysis to referential expressions, given that they have the same discourse dependent distribution.

- (11) a. Çocuklar gel-di. *Çocuk-lar masaya oturdu. *Çocuklar yemek yedi.
 Children come-past children table-dat sit-past children meal eat-past
- b. Çocuklar gel-di. *Masaya oturdu-Ø. *Yemek yedi- Ø.
 Children come-past table-dat sit-past meal eat-past
- c. Çocuklar gel-di. Masaya oturdu-lar. Yemek yedi-ler.
 Children come-past table-dat sit-past-3rd p.pl meal eat-past-3rd p.pl
- d. Çocuklar gel-di-ler. Masaya oturdu-lar. Yemek yedi-ler.
 Children come-past-3rd p.pl table-dat sit-past-3rd p.pl meal eat-past-3rd p.pl
 ‘The children came. The children sat at the table. The children ate their meal.’
- (Öztürk 1999, 22)

As the ungrammaticality of (11a) illustrates when there is not a topic shift, the occurrence of the referential expression in the first sentence is sufficient, its repetition rendering the sentence ungrammatical. However in the absence of a referential expression agreement marker on the predicate is required as the ungrammaticality of (11b) versus the grammaticality of (11c-d) indicate.

The following representation in (12) illustrates the structure of a sentence with the referential expression ‘*çocuklar*’.

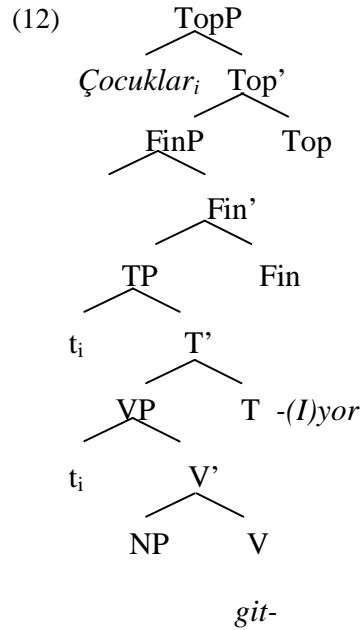

Öztürk (1999) suggests that two analyses can be made on referential expressions. Either the subject which is base generated in [Spec VP] moves from [Spec TP] to [Spec TopP] or similar to overt pronouns the referential expressions are also base generated in [Spec TopP].¹

5.3 Subject Position above *v*P Domain

Within the assumptions of Öztürk (1999, 2001), the overt pronouns are base generated in [Spec TopP] and the agreement markers which are pronominal in nature move from [Spec VP] to [Spec TP]. Öztürk (1999, 2001) extends her analysis to referential expressions and suggests that they are also base generated in TopP or move from [Spec VP] to TP to [Spec TopP].

¹ Öztürk (2004, 2005) revises her account and argues that subjects in Turkish also show A properties being in [Spec TP].

If these assumptions are on the right track, then the subject in [Spec TopP] is expected to show binding relations and scope readings relevant to A-bar domain. In the literature the tests to determine the position of the preverbal subject has been on SVO languages which have the word order possibilities of VSO/VOS based on interpretation of QPs, distributional facts, binding and reconstruction relations (Alexiadou and Anagnostopoulou 1998, Suñer 2002).

In what follows, we will discuss whether the target position of the Nominative/Genitive subjects is an A or A' domain. Section 5.3.1 presents some tests which reveal the target position of the subjects. Section 5.4 turns to the status of EPP in Turkish and discusses whether it is an independent syntactic mechanism or not.

5.3.1 TP Domain

Within the assumptions of the MP, T head inherits phi features and EPP feature from C head and attracts the subjects to its specifier position. In section 5.3.1.1 with quantifier phrases, in section 5.3.1.2 with reconstruction test, and in section 5.3.1.3 with NPI and binding test we will find out whether the Nominative/Genitive subjects in Turkish are attached to [Spec TP] in narrow syntax.

5.3.1.1 Quantifier Phrases

Interpretation of QPs in Turkish depends not on the position of the quantifiers but on the linear order as it has already been proposed by Kural (1997) and Göksel (1998).

Göksel (1998) suggests that it is the order of the existential and universal quantifiers in a sentence that determines the distributive or non-distributive reading as illustrated in (13a-b).

- (13) a. Her çocuk bir öğretmene çiçek verdi.
Every child a teacher (DAT) flower gave
'Every child gave flowers to a teacher.'

i. distributive reading: For every child there was a teacher, such that each child gave flowers to a (different) teacher

ii. non-distributive reading: there was some teacher to whom every child gave flowers.

- b. Bir çocuk her öğretmene çiçek verdi.
a child every teacher (DAT) flower gave
'A child gave flowers to every teacher.'

i. *distributive reading: for every teacher there was a child, such that each teacher received flowers from a (different) child.

ii. non-distributive reading: there was some child who gave flowers to every teacher.

(Göksel 1998, 1)

In (13a) the universal quantifier '*her*' precedes the existential quantifier '*bir*' while in (13b) the order is the reverse. Note that this linear order also reflects the interpretation of the quantifiers.

In (13a) distributive reading is possible as the universal quantifier precedes the existential quantifier. In (13b) on the other hand only non-distributive reading is possible as existential quantifier phrase precedes the universal quantifier phrase in the linear order.²

When both of the quantifier phrases are preverbal, the interpretation depends on the order of the quantifier phrases in the sentence. Kural (1997), on the other hand, posits the Scope Preservation Principle based on c-command relations and formulates it in the following way:

Scope Preservation Principle (Kural, 1997)

'If QP1 c-commands QP2 at S-Structure, it also c-commands QP2 at LF'.

When one of the QPs is moved to post-verbal position, Kural (1997) claims that post verbalized constituent (PVC) takes scope over the preverbal QP as post-verbal constituent is higher than the preverbal subject position.

² Note that in (13a), when the universal quantifier phrase '*her çocuk*' c-commands the existential quantifier phrase '*bir öğretmen*', the structure is ambiguous which means the existential quantifier phrase can scope over the universal quantifier phrase. When the existential quantifier phrase '*bir öğretmen*' scrambles over the universal quantifier phrase '*her çocuk*' the structure is not ambiguous and only the existential quantifier phrase can scope over the universal quantifier phrase as pointed out by Keleşir (2001). This contrast indicates that existential quantifier phrase can undergo LF raising but universal quantifier phrase cannot.

- (14) a. Herkes dün aramış [üç kişi]yi.
 Everyone-NOM yesterday call-PAST-3SG three person-ACC
 ($3y \forall x [x \text{ called } y \text{ yesterday}]$; * $\forall x 3y [x \text{ called } y \text{ yesterday}]$)
- b. [Üç kişi]yi dün aramış herkes.
 Three person-ACC yesterday call-PAST-3SG everyone-NOM
 ($\forall x 3y [x \text{ called } y \text{ yesterday}]$; * $3y \forall x [x \text{ called } y \text{ yesterday}]$)
 ‘Everyone called three people yesterday.’

In (14a-b) the post-verbal constituent takes scope over the quantifier phrase in the preverbal position. Thus in (14a) only non-distributed reading is possible while in (14b) distributed reading is possible as post-verbal constituent takes scope over the existential QP.

However the wide scope of the existential quantifier in (14a) can also be attributed to its being specific with the accusative case marker as has already been noted by Göksel (1998).

- (15) a. Her hastaya bakıyor bir hemşire.
 Every patient(DAT) is seeing a nurse
 ‘A nurse is seeing every patient.’ (Distributive reading available)
- b. Bir hemşire bakıyor her hastaya.
 a nurse is seeing every patient(DAT)
 ‘A nurse is seeing every patient.’ (Distributive reading unavailable)

As the example in (15a) indicates when the post-verbal quantifier phrase is a bare constituent the linear order of the constituents determines the scope reading. In (15b) only specific reading of the existential QP is available as the order of the quantifier phrases in the sentence indicates.

The behavior of the post and preverbal quantifiers has shown that in Turkish it is a combination of the linear order of the quantifier phrases and stress not their position that determines their interpretation. Thus interpretation of the quantifier phrases is not a conclusive test in Turkish for determining the subject positions.

Instead we will focus on the reconstruction properties of subjects in section 5.3.1.2 and NPIs and binding test in section 5.3.1.3 to find out the position of the subjects.

5.3.1.2 Reconstruction Test

We will test the reconstruction effects in subject to subject raising constructions in Turkish as illustrated in (16-17). In all the (a) examples the subject in the embedded clause does not move to matrix clause. In the (b) examples on the other hand the subject moves to matrix clause as its position to the dative experiencer indicates.

- (16) a. Bana [sadece o kitabı okumuş] gibi görünüyor.
I-DAT only she-NOM book-ACC read-past-3SG like appear-PROG
'She seems to me to have only read the book'
'Only she seems to me to have read the book.'

b. O_i bana [sadece t_i kitabı okumuş] gibi görünüyor.³

‘She seems to me to have only read the book’

(17) a. Bana [kimse kitabı okumamış] gibi görünüyor.

I-DAT [nobody book-ACC read-NEG-PAST-3SG] like appear-PROG-3SG

‘Nobody seems to me to have read the book.’

b. *Kimse_i bana [t_i kitabı okumamış] gibi görünüyor.

Nobody I-DAT book- ACC read-NEG-PAST-3SG like appear-PROG-3SG

‘Nobody seems to me to have read the book.’

(18) Ayşe_i bana [t_i kitabı okumamış] gibi görünüyor.

Ayşe-nom I-DAT book- ACC read-NEG-PAST-3SG like appear-PROG-3SG

‘It seems to me that Ayşe has not read the book.’

³ The structure in (16a) is ambiguous only under non-focal reading. Replacing focus on the subject or on the embedded predicate can change the scope readings and make the structure unambiguous as illustrated in (1a-b) below.

(1) a. Ban-a [sadece o kitab-ı OKU-MUŞ] gibi görün-üyor
I-DAT only she-NOM book-ACC read-past-3SG like appear-PROG
‘She seems to have only read the book.’

b. Ban-a [sadece O kitab-ı oku-muş] gibi görün-üyor
I-DAT only she-NOM book-ACC read-past-3SG like appear-PROG
‘Only she seems to me to have read the book’

When the embedded subject moves to matrix clause, scope readings may change based on the position of focus as illustrated in (2a-b) below.

(2) a. O_i ban-a [sadece t_i kitab-ı oku-muş] gibi görün-üyor.
She-NOM I-DAT only book-ACC read-PAST-3SG like appear-PROG
‘Only she seems to have read the book.’

b. O_i ban-a [sadece t_i kitab-ı OKU-MUŞ] gibi görün-üyor.
She-NOM I-DAT only book-ACC read-PAST-3SG like appear-PROG
‘She seems to have only read the book.’

In (16a) the focus particle takes scope over both the embedded subject and the embedded predicate; hence there are two reading possibilities. In (16b) the subject moves to matrix clause as the word order variation indicates.

The fact that reconstruction to the embedded clause is predicted to change scope readings but that (16b) is unambiguous is evidence that the movement of the subject in (16b) is to an A position, not to CP domain.

In (17a) the negative polarity item '*kimse*' is in the embedded clause and the negative element can c-command it in the embedded clause. (17b) is ungrammatical as the negative polarity item is no longer in the embedded clause and the negative element cannot c-command the negative polarity item in the matrix clause. The ungrammaticality of (17b) also shows that reconstruction is not possible. We therefore conclude that in (17b) '*kimse*' is in [Spec TP] not in [Spec TopP].

Similarly in (18) we assume that the subject which is a referential expression has also moved to the same target position as the subject in (17b). The structure is grammatical as there is no NPI.

Consequently we conclude that subjects in Turkish do not always move to CP level as illustrated in the examples above. [Spec TopP] is an A' position and new binding relations or scope readings are not expected as reconstruction is possible from this position. However, the data with the scope of the negation indicate that the target position of the subject in (16-17) is an A position.

5.3.1.3 NPIs and Binding Facts

Section 5.3.1.2 has illustrated that Nominative subject moves to [Spec TP]. In what follows, we will illustrate the target position of the Genitive subject. As mentioned before in section 2.4.1, NPI should be immediately c-commanded by negation in order to be licensed.

- (19) a. Bana hiçkimse-nin sınav-a çalış-ma-dıĝ-ı haber-i
 I-DAT nobody-GEN exam-DAT study-NEG-AGR_{NOM} news-CM-DAT

 inandırıcı gel-i-yor.
 convincing seem-NEG-PROG

 ‘The news that nobody studied for the exam sounds convincing to me.’

- b. * Hiçkimse-nin bana sınav-a çalış-ma-dıĝ-ı haber-i
 nobody-GEN I-DAT exam-DAT study-NEG-AGR_{NOM} news-CM-DAT

 inandırıcı gel-i-yor.
 convincing seem-NEG-PROG

 ‘The news that nobody studied for the exam sounds convincing to me.’

In (19a) NPI ‘*hiçkimsenin*’ is within the scope of negation and as the word order indicates it has not moved to matrix clause. In (19b) NPI has moved to matrix clause preceding the dative experiencer but the structure is ungrammatical. NPI is licensed within the embedded clause in (19a) but negation in the embedded clause cannot license

the NPI in the matrix clause and this yields ungrammaticality. As NPI is licensed within its own clause in (19a) and reconstruction is not possible in (19b), we conclude that the NPI occupies the subject position, A domain, in both (19a-b).

Now we turn to binding tests. The binding test is a conclusive one because a lexical item can bind another item in an A domain while new binding relations are not expected from an A' domain as reconstruction is possible (Chomsky 1981).

(20) a. Ayşe_i anne-si-nin_{i/*j} herkes-i_{*j} gör-düğ-ün-ü
 Ayşe-NOM mother-Poss-GEN everybody-ACC see-AGR_{NOM}-ACC

san-ıyor.

think-PROG-3SG

‘Ayşe thinks that her mother saw everyone’ Non-distributive reading

b. Ayşe_j herkes-i_i anne-si-nin_{i/j} gör-düğ-ün-ü
 Ayşe-NOM everybody-ACC mother-Poss-GEN see-AGR_{NOM}-ACC

sanıyor

think-PROG-3SG

‘Ayşe thinks that everyone’s mother saw him/her.’ Distributive reading

In (20a) the matrix subject is co-indexed with the genitive marked subject in the embedded clause. The embedded subject cannot be co-indexed with the embedded object and hence only non-distributive reading is possible.

When the object scrambles to a position preceding the embedded subject as illustrated in (20b) on the other hand, a new binding relation is formed. The scrambled object can be co-indexed with the genitive marked subject making distributive reading possible. Reconstruction of the embedded object creates new binding relations.

Then the target position of the scrambled object is to an A domain not an A' domain which gives us clues as to the position of the genitive subject as well. If the scrambled object is in an A domain, the subject which is to the right of the object is in A domain and hence we conclude that the Genitive subject moves to [Spec TP] as is the case with Nominative subjects, not to CP domain which is an A' domain.

Then the next question is if the object is in an A domain, in [Spec TP] what is the position of the embedded subject. We assume that TP projects multiple specifier positions and the scrambled object occupies the higher specifier position and the genitive subject the lower [Spec TP].

The tests we have shown indicate that the Genitive subjects similar to Nominative subjects are base generated in [Spec ν P] and move to [Spec TP]. However as illustrated in detail 4.3.2 and discussed in Öztürk (in press), Öztürk (2005) suggests that Genitive subject is in a higher position than the Nominative subject.

Öztürk (p.c.) suggests the following example based on scope readings as evidence that Genitive subject can be in a higher position than Nominative subject. However there are different judgments with respect to the interpretation of these structures which indicates dialectal differences.

(21) a. Bütün çocuk-lar kitab-ı oku-ma-dı söylenti-si doğru değil.

All children-NOM book-ACC read-NEG-PAST rumor-CM true not

‘The rumor that all the children did not read the book is not true.’

b. Bütün çocuk-lar-ın kitab-ı oku-ma-dı-ğ-ı söylenti-si doğru değil.

All children-GEN book-ACC read-NEG-DIK-AGR_{NOM} rumor-CM true not

‘The rumor that all the children did not read the book is not true.’

According to one interpretation in (21a) with the nominative subject, Negation takes wide scope over the nominative subject so we get the reading that some of the children read the book while some others did not. In (21b) with the Genitive subject on the other hand the subject may take wide scope over the Neg head which indicates that Genitive subject is in a higher position than the Nominative subject.

According to another interpretation on the other hand, Nominative subject in (21a) can take scope over Negation as is the case with Genitive subject in (21b). This indicates that the position of the Nominative and Genitive subjects is the same for some speakers.

Based on the tests given in the preceding sections we conclude that Nominative/Genitive subjects are base generated in [Spec vP] and move to [Spec TP].

5.4 Is EPP Redundant or not?

Once we have determined that Nominative and Genitive subjects move to [Spec TP] the next question to be answered is whether EPP can be dispensed with in favor of other syntactic mechanisms like Case/Agreement. Now we turn to the case licensing mechanism proposed for CNPCs in Turkish to find out the answer of this question.

Recall that features as case licenser analysis made for CNPCs in Turkish assumes Agree mechanism for Case and Agree.

- (22) Ahmet para-yı çal-mış dedikodu-su
Ahmet-NOM money-ACC steal-PAST-3SG rumor-CM
'The rumor that Ahmet stole the money'

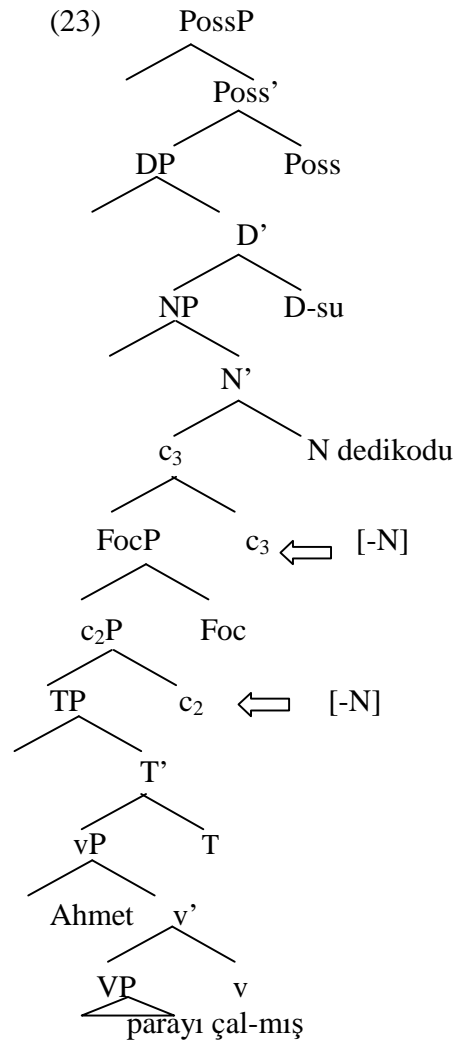

The feature inserted at c_2 level determines the categorial nature of the complement domain as nominal or verbal. [-N] feature inserted at c_2 determines this domain as verbal. At c_3 on the other hand [-N] feature is inserted determining the case on the subject as Nominative. c_2 transmits its uninterpretable phi features to T head and c_2 -T Agree with the subject in [Spec vP] position. Uninterpretable phi features of the probe are valued and verbal agreement markers appear on the embedded predicate as

[-N] is inserted at c_2 . As a reflex of this feature valuation Nominative case is licensed on the subject.

Note that the Nominative case on the subject is licensed in-situ and c_2 -T amalgamate does not trigger the movement of the subject to [Spec TP] to check its uninterpretable phi features.

Given that the tests we have applied have shown above that Gen/Nom subjects move to an A domain, we conclude that Nominative and Genitive subjects move to [Spec TP]. The case licensing mechanism which is based on feature transmission and Agree has further demonstrated that the movement of the subject to higher functional projections is not for Case/Agreement purposes. Genitive and Nominative subjects are in the same position at the point where case is licensed but move to higher functional projections for EPP purposes.

5.5 Summary

This chapter has analyzed the subject movement in Turkish. The subjects in Null subject languages are assumed to be projected in or move to [Spec TopP] as it has been proposed for Greek and Spanish by Alexiadou and Anagnostopoulou (1998) and for Turkish by Öztürk (1999). We have concluded that Nominative subjects move to [Spec TP] based on the reconstruction test which indicates that Nominative subjects show A domain properties in Turkish. As for Genitive subject we have suggested that as is the case with Nominative subjects, Genitive subjects move to A domain. NPI and binding test in section 5.3.1.3 has further illustrated that Genitive subjects also move to [Spec TP].

The movement of the subjects to [Spec TP] cannot be attributed to any syntactic mechanism other than EPP. Within the assumptions of the case licensing mechanism introduced in chapter four, Case/Agreement is checked in-situ in Turkish and hence the subject has no trigger other than EPP to move to a higher functional projection.

CHAPTER SIX

CONCLUSION

This thesis investigated (i) CNPC variants in Turkish with their structural properties, (ii) Nom/Gen case licensing mechanism in CNPCs, in certain complement and adjunct clauses and –DIK type of relative clauses in Turkish, (iii) the movement operations of the subjects and possible target positions, (iv) the nature of case licensing and the status of EPP in Turkish.

Chapter I presented some of the CNPC variants in Turkish some of which have not been studied in the previous studies and the basic tenets of the MP.

Chapter II illustrated CNPC variants which are similar in structure to compounds in Turkish. In order to find out all the possible realizations of CNPCs in Turkish we applied a grammaticality judgment test based on which we concluded that there are two dialects. Dialect A speakers form the majority in the group and do not allow Gen/Nom alternation in any of the CNPCs. For Dialect A speakers genitive case marked nominal is either the genitive possessor or part of an elliptical clause. The speakers of Dialect B which is marginal and restricted to some CNPCs and/or speakers allow Gen/Nom alternation and interpret the genitive case marked nominal as the subject in some specific CNPCs.

Chapter III illustrated Nom/Gen subject case variation in certain complement and adjunct clauses, relative clauses, and CNPCs in Turkish. This chapter also introduced previous studies on subject case variation in Turkish which were divided into two

groups: Base Generation (Öztürk 2005) and Movement Analysis (Kural 1995, Aygen 2002, Kornfilt 2003, Ulutaş 2008).

Chapter IV discussed case licensing mechanism for CNPCs in Turkish taking Features as Case Licenser approach as a basis and proposed that:

(i) Turkish allows a four way variation with respect to the features inserted at phase heads c_2 and c_3 . The genitive marked nominals in some specific CNPCs in Dialect B is interpreted to be the subject in the embedded clause and through pre-conditions for genitive case licensing proposed for Turkish, genitive case on the nominal is explained. The genitive marked nominal in Dialect A, on the other hand is either the genitive possessor or part of an elliptical clause and hence they are analyzed as pseudo Nom/Gen alternation.

(ii) Nom/Gen subjects are at the same position in the derivation where case is checked and subject case alternation in CNPCs is due to the nature of the features inserted at phase heads. Pre-conditions defined for Turkish predict Genitive case licensing in CNPCs, complement and adjunct clauses and –DIK type of relative clauses.

Chapter V dealt with target positions of the Nom/Gen subjects and explored the relationship between EPP and other syntactic mechanisms such as Case/Agree. Based on reconstruction, NPIs and binding tests we proposed that:

(i) Nom/Gen subjects move to [Spec TP] as the movement operations show A domain properties.

(ii) Movement of the Nom/Gen subject to [Spec TP] is for EPP purposes but not for Case/Agree purposes as these are checked in base generated position.

Within the model proposed for Turkish, CP projection is split into phase heads c_2 and c_3 which can be analyzed as FinP and ForceP respectively within Rizzi's (1997) Split CP hypothesis. Being analyzed as phase heads c_2 and c_3 are the locus of features inserted at Transfer. The nature of the features inserted at phase heads determine the agreement markers on the embedded predicate and also the case marker on the subject. Through these phase heads, variation in the nature of the agreement markers on the predicate and Nom/Gen subject case valuation can be explained for Turkish without appealing to different functional projections. This analysis has the advantage over the analyses which assume different functional projections for Nom/Gen case checking in that not only the subject case but also the inflectional morphology on the embedded predicate receives an explanation through the nature of the features inserted at phase heads.

This analysis also makes some certain predictions with respect to case licensing mechanism in ECM clauses in Turkish which have the same inflectional morphology with finite complement clauses as discussed in chapter 3. In ECM clauses, the embedded subject agrees with the c_2 -T amalgamate in the embedded clause as agreement markers appear on the embedded predicate however Accusative case is valued on the subject. CP and ν P, being phase heads, are the locus of all features and EF, and hence Accusative case is valued by ν -V amalgamate (Chomsky 2008). In a similar vein with Nom/Gen case valuation by C-T system, matrix ν percolates its features down to V. ν -V amalgamate probes into embedded clause and agrees with the embedded subject valuing

its case as Accusative. This analysis raises the question whether the accusative subject moves to matrix clause with the EF of vP after case valuation. There have been many analyses in Turkish which support the view that Accusative subject moves to the matrix clause based on adverb placement, NPIs and word order facts (Zidani- Eroğlu 1997, Kural 1997, Özsoy 2001). Some researches on the other hand argue that Accusative subject does not move to matrix clause (Aygen 2000, Öztürk 2004, 2005, Oded 2006). Then the phase head c_3 is either defective as case valuation of the subject DP by a higher probe is allowed and movement of the Accusative subject to the matrix clause is licit or c_3 is missing in the structure. For conclusive tests on the status of c_3 in ECM clauses within this model we leave this discussion for further research.

We have analyzed CNPCs as higher order compounds however it is not easy to identify the domain of compounding. As compounding has links with syntax and morphology, the domain of compound formation has been an intriguing issue in the literature. Compounding has been proposed as a lexical process (Di Sciullo and Williams 1987), or as a syntactic process (Fabb 1984, Lieber 1988). Shibatani and Kageyama (1988) on the other hand suggest that compounding may take place at several levels including lexicon, syntax, and phonology. As illustrated in chapter 2, compounds (i) are lexicalized in that they have idiosyncratic meanings, (ii) are non-referential in that they do not refer to specific objects (iii) form a morphological unit and it is not possible to insert lexical items between the head and the complement, which leads us to define the compound formation domain as lexicon. However compounds (i) are recursive (ii) may have constituent structure, which makes compounding process closer to syntax.

CNPCs which are analyzed as higher order compounds also have lexical or phrasal properties which pose a problem similar to simple compounds in terms of defining the derivational domain. As illustrated in detail in chapter 2, CNPCs (i) bear the same inflectional morphology as simple compounds and well-formedness conditions (i.e. the co-occurrence restrictions of compound marker and the possessive agreement markers) apply in CNPCs as well, (ii) insertion of a lexical item between the complement and the head noun is not allowed. However as discussed in chapters 4 and 5, CNPCs also have properties which moves them closer to the syntactic domain. The complement in CNPCs can be nominalized clauses or finite clauses and hence they are labeled as 'higher order compounds'. Within these complement domains case checking mechanism applies and subject movement operations are observed. In line with Shibatani and Kageyama (1988), we assume that compounding is not restricted to a single level, compound formation can be at the level of lexicon with simple NPs or at a level after syntactic rules have been applied to the phrase.

There are still a number of issues the discussion of which we left for further research. Through some tests (i.e. binding and reconstruction tests), [Spec TP] has been proposed as the target position for the Nominative/Genitive subjects. However as suggested by Öztürk, it is possible to suggest that Genitive is in a higher position than the Nominative subject based on the contrast between Gen/Nom subjects with respect to the extraction possibilities and topicalization properties. This issue needs further conclusive tests which we leave for future studies.

We have suggested that Gen/Nom case alternation is restricted to certain CNPCs. It is hoped that further research will contribute to a better understanding of the nature of Nom/Gen case alternation in Turkish.

APPENDIX

A

1. “Konferans-a hiç kimse-nin hazırlan-ma-mış-tı”
conference-DAT anybody-GEN be prepared-NEG-InferentialPAST-PAST-3SG

iddia-sın-a inan-dı-m.
claim-CM-DAT believe-PAST-1SG
‘I believed in the claim that nobody had been prepared for the conference.’
2. “Sen ev-de-sin” laf-ı biz-e ulaş-ma-dı.
you-NOM home-LOC-AGR_{NOM} remark-CM we-DAT reach-NEG-PAST
‘The remark that you are at home did not reach us.’
3. Ayşe-nin “sen-in bit-miş-sin” düşünce-sin-i
Ayşe-GEN you-GEN exhausted-PAST-2PSG idea-3SGPoss-ACC

paylaş-mı-yor-um.
share-NEG-PROG-1PSG
‘I do not share Ayşe’s idea that you are exhausted.’
4. “Kar-da hiç kimse-nin yürü-me-sin” fikr-i-ne katıl-ıyor-um.
snow-LOC anybody-GEN walk-NEG-IMP idea-CM-DAT agree-PROG-1SG
‘I agree with the idea that nobody should walk on the snow.’

5. “Kar-da biz-im kay-ma-z mı-yız”
snow-LOC we-GEN slip-NEG-AOR question marker-1PL
soru-su ben-i şaşırt-tı.
question-CM I-ACC astonish-PAST
‘The question whether we would not slip on the snow made me astonished.’
6. “Kitab-a hiç kimse-nin bak-ma-mış-tır” düşünce-sin-e
book-DAT anybody-GEN look-NEG-PAST-MOD opinion-CM-DAT
katılıyorum.
agree-PROG-1SG
‘I agree with the opinion that nobody looked at the book.’
7. “Sen-in tatil-e çık-tı-n” dedikodu-su
you-GEN holiday-DAT go-PAST-2PSG rumor-CM
herkes-in ağız-ın-da.
everybody-GEN mouth-3SGPoss-LOC
‘The rumor that you went on a holiday is talked by everybody.’
8. “Arkadaş-lar-ımız-ın topluca koş-muş-tur” haber-i gel-di.
friend-PL-1PLPoss-GEN altogether run-PAST-MOD-3SG news-CM come-PAST
‘The news that our friends ran altogether came.’
9. “Bırak-ıp biz-im gid-iyor-sunuz” fikr-i Ayşe-den çık-mış.
leave-adverbializer we-GEN go-PROG-2PSG idea-CM Ayşe-ABL come-PAST
Intended meaning: ‘The idea that you leave us and go is the idea of Ayşe.’

10. Murat-ın “bit-miş-sin” düşünce-sin-i paylaş-mı-yor-um.
Murat-GEN exhausted-PAST-2PSG idea-3SGPoss-ACC agree-NEG-PROG-1PSG
‘I do not agree with Murat’s idea that you are exhausted.’

11. “Ev-de-ki-ler hasta-ydı” laf-ı doğru değil.
home-LOC-REL-PL ill-PAST remark-CM true not
‘The remark that the ones at home were ill is not true.’

12. “Tatil-e hiç kimse-nin çık-ma-malı” emr-i
holiday-DAT anybody-GEN go-NEG-Necessitative command-CM
can-ımız-ı sık-tı.
life-1PLPoss-CM annoy-PAST
‘The command that nobody should go on a holiday annoyed us.’

13. “Kız-ım-a sen-in bağır-mış-sın” iddia-sı
daughter-1SGPoss-DAT you-GEN shout-PAST-2SG claim-CM
ben-i üz-dü.
I-ACC upset-PAST
‘The claim that you shouted at my daughter upset me.’

14. “Kız-ım-a sen-in bağır-mış-ım” iddia-sı
daughter-1SGPoss-DAT you-GEN shout-PAST-1SG claim-CM
ben-i üz-dü.
I-ACC upset-PAST
Intended Meaning: ‘Your claim that I shouted at my daughter upset me.’

15. Murat-ın “hiçkimse-nin okul-a git-me- meli”
Murat-GEN anybody-GEN school-DAT go-NEG-Necessitative

laf-1 çok şaşırtıcı.
statement-3SGPoss very astonishing

‘Murat’s statement that nobody should go to school is very astonishing.’

B

1. Konferans-a hiç kimse-nin hazırlan-ma-mış-tı
conference-DAT anybody-GEN be prepared-NEG-InferentialPAST-PAST-3SG

iddia-sın-a inan-dı-m.
claim-CM-DAT believe-PAST-1SG

‘I believed in the claim that nobody had been prepared for the conference.’

2. Sen ev-de-sin laf-ı biz-e ulaş-ma-dı.
you-NOM home-LOC-AGR_{NOM} remark-CM we-DAT reach-NEG-PAST

‘The remark that you are at home did not reach us.’

3. Ayşe-nin sen-in bit-miş-sin düşünce-sin-i
Ayşe-GEN you-GEN exhausted-PAST-2PSG idea-3SGPoss-ACC

paylaş-mı-yor-um.
share-NEG-PROG-1PSG

‘I do not share Ayşe’s idea that you are exhausted.’

4. Kar-da hiç kimse-nin yürü-me-sin fikr-i-ne katıl-ıyor-um.
snow-LOC anybody-GEN walk-NEG-IMP idea-CM-DAT agree-PROG-1SG
'I agree with the idea that nobody should walk on the snow.'

5. Kar-da biz-im kay-ma-z mı-yız
snow-LOC we-GEN slip-NEG-AOR question marker-1PL
soru-su ben-i şaşırt-tı.
question-CM I-ACC astonish-PAST
'The question whether we would not slip on the snow made me astonished.'

6. Kitab-a hiç kimse-nin bak-ma-mış-tır düşünce-sin-e
book-DAT anybody-GEN look-NEG-PAST-MOD opinion-CM-DAT
katılıyorum.
agree-PROG-1SG
'I agree with the opinion that nobody would have looked at the book.'

7. Sen-in tatil-e çık-tı-n dedikodu-su
you-GEN holiday-DAT go-PAST-2PSG rumor-CM
herkes-in ağz-ın-da.
everybody-GEN mouth-3SGPoss-LOC
'The rumor that you went on a holiday is talked by everybody.'

8. Arkadaş-lar-ımız-ın topluca koş-muş-tur haber-i gel-di.
friend-PL-1PLPoss-GEN altogether run-PAST-MOD-3SG news-CM come-PAST
'The news that our friends ran altogether came.'

9. Bırak-ıp biz-im gid-iyor-sunuz fikr-i Ayşe-den çık-mış.
leave-adverbializer we-GEN go-PROG-2PSG idea-CM Ayşe-ABL come-PAST
Intended meaning: ‘The idea that you leave us and go is the idea of Ayşe.’

10. Murat-ın bit-miş-sin düşünce-sin-i paylaş-mı-yor-um.
Murat-GEN exhausted-PAST-2PSG idea-3SGPoss-ACC agree-NEG-PROG-1PSG
‘I do not agree with Murat’s idea that you are exhausted.’

11. Ev-de-ki-ler hasta-ydı laf-ı doğru değil.
home-LOC-REL-PL ill-PAST remark-CM true not
‘The remark that the ones at home were ill is not true.’

12. Tatil-e hiç kimse-nin çık-ma-malı emr-i
holiday-DAT anybody-GEN go-NEG-Necessitative command-CM

can-ımız-ı sık-tı.
life-1PLPoss-CM annoy-PAST
‘The command that nobody should go on a holiday annoyed us.’

13. Kız-ım-a sen-in bağır-mış-sın iddia-sı
daughter-1SGPoss-DAT you-GEN shout-PAST-2SG claim-CM

ben-i üz-dü.
I-ACC upset-PAST
‘The claim that you shouted at my daughter upset me.’

14. Kız-ım-a sen-in bağır-mış-ım iddia-sı
daughter-1SGPoss-DAT you-GEN shout-PAST-1SG claim-CM

ben-i üz-dü.

I-ACC upset-PAST

Intended Meaning: ‘Your claim that I shouted at my daughter upset me.’

15. Murat-ın hiçkimse-nin okul-a git-me- meli
Murat-GEN anybody-GEN school-DAT go-NEG-Necessitative

laf-ı çok şaşırtıcı.

statement-3SGPoss very astonishing

‘Murat’s statement that nobody should go to school is very astonishing.’

REFERENCES

- Alexiadou, A. & E. Anagnostopoulou (1998) "Parametrizing AGR: Word Order, Verb-movement and EPP checking." *Natural Language and Linguistic Theory* 16.3: 491-539.
- Arslan-Kechriotis, C. (2006) *Case as an Uninterpretable Feature*. Unpublished Ph.D. Thesis. Boğaziçi University.
- Aygen, G. (2000). V-to-T-to-C: extractable subjects and EPP. *Proceedings of WECOL*.
- Aygen, G. (2002) *Finiteness, Case and Clausal Architecture*. Unpublished Ph.D. Thesis. Harvard University.
- Aygen, G. (2007) Syntax and Semantics of Subject Case in Turkic. *California Linguistic Notes*, Volume XXXII, 2.
- Banguoğlu, T. (1998). *Türkçenin Grameri*. Ankara: Ankara Üniversitesi Basımevi.
- Barker, C., Hankamer, J., and Moore, J. (1990) Wa and ga in Turkish. In *Grammatical Relations: a cross-theoretical perspective*, ed. K. Dziwirek and P. Farrell, CSLI, Stanford.
- Bobaljik, J. D. & Dianne, D. (1996) Subject positions and the roles of TP. *Linguistic Inquiry* 27.2, 195-236.
- Bobaljik, J. D. & Wurmbrand, S. (2007) Case in GB/Minimalism. Ms. Univ. of Connecticut.
- Bošković, Ž. & Lasnik H. (eds.) (2007) *Minimalist Syntax: The Essential Readings*. Blackwell.
- Cagri, I. (2005) *Minimality and Turkish Relative Clauses*. Ph.D. dissertation, University of Maryland, College Park.
- Chomsky, N. (1980). 'On Binding.' *Linguistic Inquiry* 11:1-46.
- Chomsky, N. (1981). *Lectures on Government and Binding*. Dordrecht: Foris.
- Chomsky, N. (1982). *Some Concepts and Consequences of the Theory of Government and Binding*. Cambridge, Mass: MIT Press.

- Chomsky, N. (1993) "A Minimalist Program for Linguistic Theory," in K. Hale & S. J. Keyser, eds., *The View From Building 20*, Cambridge: MIT Press. (revised version of Chomsky (1992) 1-49.
- Chomsky, N. (1995) *The Minimalist Program*. Cambridge, MA: The MIT Press.
- Chomsky, N. (1999) Derivation by phase. Cambridge, Massachusetts: MITWPL
- Chomsky, N. (2000) Minimalist inquiries: the framework. In R. Martin et al. (eds.), *Step by Step: Essays on minimalist syntax in honor of Howard Lasnik*, 89-155. MIT Press.
- Chomsky, N. (2001) 'Derivation by phase.' In Michael Kenstowicz (ed.) *Ken Hale: A life in language*, Cambridge, Mass: MIT Press, 1-52.
- Chomsky, N. (2004) On phases. Ms., MIT,
- Chomsky, N. (2005) On Phases. Manuscript, Massachusetts Institute of Technology, Massachusetts.
- Chomsky, N. (2008) On Phases. In Freidin, Robert, Carlos P. Otero and Maria Luisa Zubizarreta (eds.), *Foundational Issues in Linguistic Theory*, 133-166. Cambridge, MA: MIT Press.
- Chomsky, N., and Howard L. (1993). 'The Theory of Principles and Parameters.' In Noam Chomsky (ed.) *The minimalist program*. Cambridge, MA: MIT Press, 13-127
- Davies, W., Dubisky, S. (2001) Objects and other subjects: Grammatical functions, functional categories, and configurationality. *Studies in Natural Language and Linguistic Theory* 52. Dordrecht: Kluwer Academic Press.
- Dede, M. (1978) *A Syntactic and Semantic Analysis of Turkish Nominal Compounds*. Ph.D Thesis. University of Michigan
- Enç, M. (1986) Topic switching and pronominal subjects in Turkish. In *Studies in Turkish Linguistics*, D.I. Slobin and K. Zimmer, (eds.), 195-209. Amsterdam: John Benjamins.
- Epstein, S., and T. Seely. (2006) *Derivations in Minimalism*. Cambridge University Press: Cambridge.
- Erguvanlı-Taylan, E. (1988). The expression of temporal reference in embedded sentences in Turkish. In *Studies in Turkish Linguistics*, S. Koç, (ed.), 333-351. Ankara: Middle East Technical University.

- Fabb, N. (1984) *Syntactic Affixation*. Ph.D. dissertation, MIT.
- Gencan, T. N. (1979). *Dilbilgisi*. Ankara: Ankara Üniversitesi Basımevi.
- George, L. M. & Kornfilt, J. (1981) Finiteness and boundedness in Turkish. In *Binding and Filtering*, ed. F. Heny, MIT Press, Cambridge.
- Göksel, A. (1988). Bracketing paradoxes in Turkish nominal compounds. In S. Koç (ed.) *Studies on Turkish Linguistics*, 287-298. Ankara: METU Press.
- Göksel, A. (1997). Word Length. *Proceedings of the First Mediterranean Conference of Morphology*, pp. 190-200.
- Göksel, A. (1997). Morphological asymmetries between Turkish and Yakut. In K. İmer and E. Uzun (eds.), *Proceedings of the 8th International Conference on Turkish Linguistics, August 7-9, 1996*, Ankara: Ankara Üniversitesi, pp. 69-76.
- Göksel, A. (1998) 'Linearity, Focus and the Postverbal Position in Turkish', in L. Johanson with É. Á. Csató. V. Locke and A. Menz (eds.) *The Mainz Meeting*. Wiesbaden: Otto Harrossowitz Verlag.
- Göksel, A. & Celia, K. (2005). *Turkish: A Comprehensive Grammar*. London: Routledge.
- Grohmann, Drury, Castillo (2000) No more EPP. *Proceedings of WCCFL 19*. Billerey and Lillehaugen (eds) Cascadilla Press: Somerville, MA. Pp. 153-166.
- Haig, G. (1997) Turkish relative clauses: a tale of two participles. *Turkic Languages* 1, 184-209.
- Hale, K., and Jay K. (1993) "On argument structure and the lexical expression of syntactic relations." In Ken Hale and Jay Keyser (eds.) *The View from Building 20: A Festschrift for Sylvain Bromberger*. Pp. 53-108. MIT Press.
- Hale, K. (2002). 'Eccentric Agreement.' in Beatriz Fernández & Pablo Albizu (eds.), *Kasu eta Komunztaduraren gainean [On Case and Agreement]*, Euskal Herriko Unibetsitatea, Vitoria-Gasteiz, pp. 15-48.
- Hale, K. (2002). 'On the Dagur Object Relative: Some Comparative Notes.' *JEAL*, 1-14, Kluwer, the Netherlands.
- Hankamer, G. and Knecht, L. (1976) 'The Role of the Subject/Non-Subject Distinction in Determining the Choice of Relative Clause Participle in Turkish.' In *Harvard Studies in Syntax and Semantics* 2, G. Hankamer and J. Aissen (eds), Harvard University, Cambridge, pp.123-135, and In *Papers from the Sixth Meeting of the Northeastern Linguistics Society*, University of Montreal, Montreal.

- Harley, H. (1995) *Subjects, Events, and Licensing*. Doctoral dissertation, MIT.
- Harada, S.-I., (1971) *Ga-no* conversion and ideolectal variations in Japanese. *Gengo Kenkyu* 60,25-38.
- Hiraiwa, K. (2005) *Dimensions of Symmetries in Syntax: Agreement and Clausal Architecture*. Ph.D. Dissertation, Massachusetts Institute of Technology, Cambridge, MA, USA.
- Hornstein, N., Nunes, J. & Grohmann K. (2005) *Understanding Minimalism*. Cambridge University Press.
- Ian R. & Anna R. (2002). The Extended Projection Principle as a Condition on the Tense Dependency. In: Svenonius, P. (ed.). *Subjects, expletives, and the EPP*. Oxford: OUP, 125 - 156.
- Kelepir, M. (2001). *Topics in Turkish Syntax: Clausal Structure and Scope*. Ph.D. dissertation, Massachusetts Institute of Technology. Distributed by MIT Working Papers in Linguistics, Cambridge, MA.
- Kelepir, M. (2006). Copula Forms in Turkish, Noghay and Turkmen. *MIT Working Papers in Linguistics* 52, 83-100
- Kennelly, S. (1992) Turkish Subordination: [-Tense, -CP,+ Case]. *The Proceedings of the sixth International Conference on Turkish Linguistics: Eskişehir, August 12, 1992*.
- Kennelly, S. (1996) Theta Control in Turkish. In *GLOW Newsletter* 24.
- Koopman, H. and D. Sportiche, (1991) "The position of subjects" in *Lingua*, 85.1, p 211-258
- Kornfilt, J. (1976) The cycle against free rule application (evidence from Turkish) *Harvard S and S* 2: 359:444.
- Kornfilt, J. (1984). *Case marking, agreement, and empty categories in Turkish*. Dissertation, Harvard.
- Kornfilt, J. (1984). 'The 'Stuttering Prohibition' and morpheme deletion in Turkish' in E. Erguvanlı-Taylan and A. Aksu-Koç (eds.) *Proceedings of the Second International Conference on Turkish Linguistics*. İstanbul: Boğaziçi University Publications.

- Kornfilt, J. (2000) Some syntactic and morphological properties of relative clauses in Turkish. In *The Syntax of Relative Clauses*, Artemis Alexiadou et al, eds., Amsterdam: Benjamins, pp. 121-159.
- Kornfilt, J. (2002) Functional Projections and their subjects in Turkish Clauses. In *The Verb in Turkish*, E. E. Taylan (ed.); Amsterdam: John Benjamins; 183-212.
- Kornfilt, J. (2003) "Subject Case in Turkish Nominalized Clauses." *Syntactic Structures and Morphological Information*. Ed. Uwe Junghanns and Luka Szucsich. Berlin, Germany: Mouton de Gruyter, 2003. 129-215.
- Kornfilt, J. (2006) "Agreement: The (unique and local) syntactic and morphological licenser of subject Case". In *Studies on Agreement*. J. Costa & M. C. Figueiredo Silva (eds.). Amsterdam and Philadelphia: John Benjamins; 141-171.
- Kornfilt, J. (2007) Verbal and Nominalized Finite Clauses in Turkish. In *Finiteness Theoretical and Empirical Foundations*, I. Nikolaeva (ed.); Oxford University Press.
- Kural, M. (1993) V-to(-C-to)-I in Turkish. *UCLA Occasional Papers in Linguistics* 11, 17-53.
- Kural, M. (1994) Infl and agreement in Turkish subordinate clauses. *Proceedings of the West Coast Conference on Formal Linguistics* 12, 339-354.
- Kural, M. (1997) Postverbal constituents in Turkish and the Linear Correspondence Axiom. *Linguistic Inquiry* 28, 498-519.
- Lasnik, H. (2001) A note on the EPP. *Linguistic Inquiry* 32:356-362.
- Lasnik, H. (2003) On the Extended Projection Principle. *Studies in Modern Grammar* 31:1-23.
- Lebeaux, D. (1988). *Language acquisition and the form of the grammar*. Doctoral dissertation, University of Massachusetts, Amherst.
- Lebeaux, D. (1991). Relative clauses, licensing, and the nature of the derivation. In *Syntax and semantics* 25, ed. by Susan Rothstein, 209-239, San Diego: Academic Press.
- Lefebvre, D. C. and Muysken P. (1988) *Mixed Categories: Nominalizations in Quechua*, Kluwer Academic Publishers
- Legate, J. A. (2003) Some interface properties of the phase. *Linguistic Inquiry* 34: 506–16.
- Lewis, G. L. (1967) *Turkish Grammar*. Oxford University Press.

- Lieber, R. (1988). Phrasal Compounds in English and the morphology-syntax interface. *Papers from the Parasession on Agreement in Grammatical Theory*. CLS 24, 202-22.
- Lyons, J. (1977). *Semantics. Volumes I and II*. Cambridge University Press, Cambridge.
- McCloskey, J. (1996). 'Subjects and subject positions in Irish', in *The Syntax of the Celtic Languages*. Robert D. Borsley and Ian Roberts (eds.), Cambridge: Cambridge University Press. 241-283.
- Milsark, G. L. (1974). *Existential sentences in English*. Ph. D. dissertation. MIT.
- Miyagawa, S. (1993) Case-checking and minimal link condition. *MIT working papers in linguistics 19: papers on case and agreement II*, ed. Collin Phillips, 213-254. Cambridge, Mass: MITWPL.
- Miyagawa, S. (2008) Genitive Subjects in Altaic. To appear in the *Proceedings of the Workshop on Formal Altaic Linguistics 4*, MITWPL
- Miyagawa, S. (2009) Genitive subjects in Altaic and Specification of Phase, to appear in a special *Lingua* volume edited by Jaklin Kornfilt and John Whitman.
- Moore, J. (1998) Turkish copy-raising and A-chain locality. *Natural Language and Linguistic Theory* 16, 149-189.
- Oded, İ. (2006) *Control in Turkish*. Unpublished MA thesis, Boğaziçi University.
- Özsoy, S. (1987) Null subject parameter and Turkish. In Boeschoten, Hendrik E. and Ludo Th. Verhoeven (eds.), *Studies on modern Turkish: proceedings of the third conference on Turkish linguistics*. Tilburg University Press, Tilburg.
- Özsoy, A. S. (1994) Relative Clauses In Turkish. *Seventh International Conference on Turkish Linguistics*. Ağustos 1994. Mainz Üniversitesi.
- Özsoy, A. S. (2001) On 'small' clauses, other 'bare' verbal complements and feature checking in Turkish. Ed. E.E. Taylan. *The Verb in Turkish*. Amsterdam. John Benjamins. 213-237.
- Özünü, Ü. (1984) Functional Notions of Turkish Verbal Adjectives in Adjective Constructions. *Hacettepe Üniversitesi Edebiyat Fakültesi Dergisi*.
- Öztürk, B. (1999) *Turkish as non-prodrop language*. MA-thesis, Boğaziçi University Istanbul.
- Öztürk, B. (2001) *Turkish as a non-pro-drop language*. In Erguvanlı-Taylan, (ed.), *The verb in Turkish*. John Benjamins, Amsterdam.239-259.

- Öztürk, B. (2004) Case, Referentiality and Non-configurationality. *Harvard University Working Papers in Linguistics*, C. Bowerman ed., Volume 10
- Öztürk, B. (2005) *Case, Referentiality and Phrase Structure*. Linguistik Aktuell, Amsterdam: John Benjamins
- Öztürk, B. (2007) Relativization Strategies in Turkish. *Proceedings of the Workshop on Altaic Formal Linguistics IV*.
- Öztürk, B. (in press) Postverbal constituents in Khalkha Mongolian and Uyghur. Rightward Movement from a Cross-linguistic Perspective, H. Walker and G. Webelhuth (ed.), *Linguistik Aktuell*, Amsterdam: John Benjamins.
- Ulutaş, S. (2008) Feature Inheritance and Subject Case in Turkish. *The International Conference on Turkish Linguistics XIV*.
- Underhill, R. (1972) Turkish Participles. *Linguistic Inquiry* 3, 87-99.
- Underhill, R. (1976). *Turkish grammar*. MIT Press, Cambridge.
- Uygun, D. (2005) *On probes, goals and subject-raising in Turkish*. Ms. Boğaziçi University, Istanbul.
- Pollock, J. (1989), “Verb Movement, Universal Grammar, and the Structure of IP.” *Linguistic Inquiry* 20: 365–424.
- Pullum, Geoffrey K. (1975). On a nonargument for the cycle in Turkish. *Linguistic Inquiry* 6, 494-501.
- Richards, M. (2008) Probing the Past: On reconciling Long-Distance Agreement with the Phase Impenetrability Condition. To appear in *Linguistische Arbeiten*.
- Rizzi, L. (1997) The fine structure of the left periphery. In L. Haegeman (ed.) *Elements of Grammar: Handbook of Generative Syntax*. Dordrecht: Kluwer, 281-337.
- Rizzi, L. & Shlonsky, U. (2005) *Strategies of Subject Extraction*. Ms. University of Siena, University of Geneva.
- Schaaik, van G. (1996). *Studies in Turkish Grammar*. Wiesbaden: Harrassowitz
- Schaaik, van G. (2001). Higher Order Compounds in Turkish. *The Bosphorus Papers: Studies in Turkish Grammar 1996-1999*. Istanbul: Boğaziçi University Press

- Schaaik, van G. (2002). *The Noun in Turkish. Its argument structure and the Compounding Straitjacet*. Wiesbaden: Harrassowitz
- Schroeder, C. (1999). *Turkish nominal phrases in spoken discourse*. Wiesbaden: Harrassowitz.
- Sells, P. (2008) Gerassimova, Veronica and Sells, Peter (2008) 'Long-Distance Dependencies in Tagalog: The Case for Raising.' In: Chang, Charles B. and Haynie, Hannah J., (eds.), *Proceedings of the 26th West Coast Conference*. Somerville, Mass.: Cascadilla Proceedings Project, pp. 190-198.
- Sigurdsson, H. (1996) Icelandic Finite Verb Agreement. *Working Papers in Scandinavian Syntax* 57: 1-46. University of Lund.
- Shlonsky, U. (2000) Subject positions and copular constructions. In H. Bennis, M. Everaert and E. Reuland (eds) *Interface Strategies*, Amsterdam: Royal, pp. 325-347.
- Shibatani, M and Kageyama, T. (1988) Word Formation in a modular theory of grammar: a case of post-syntactic compounds in Japanese. *Lg* 64, 451-84.
- Sportiche, D. (1988) A Theory of Floating Quantifiers and its Corollaries for Constituent Structure. *Linguistic Inquiry* 19: 425-449.
- Suñer, M. (2002) The Lexical Preverbal Subject in a Romance Null Subject Language: Where art thou? In *A Romance Perspective in Language Knowledge and Use*, eds. R Nuñez Cedeño, L López, and R Cameron. Amsterdam: John Benjamins.
- Svenonius, P. (2002) Subject Positions and the Placement of adverbials. In *Subjects, Expletives and the EPP*, edited by Peter Svenonius, pp. 201-242.
- Williams, E. (1994) *Thematic structure*. Cambridge, Mass.: MIT Press.
- Yumrutaş, N. (2009) *Acquisition of Relative Clauses in Turkish*. Unpublished MA Thesis. Boğaziçi University.
- Yükseker, H. (1987) Turkish Nominal Compounds. *Toronto Working Papers in Linguistics*, 7.
- Zidani-Eroğlu, L. (1997). Exceptionally Case-marked NPs as matrix objects. *Linguistic Inquiry* 28, 219-230.
- Zagona, K. (1982) *Government and Proper Government of Verbal Projections*, PhD Dissertation, University of Washington at Seattle.