

HOST-TO-HOST TCP/IP CONNECTION OVER SERIAL PORTS USING LI-FI
FOR INTERNET CONNECTION

by

Ömer Altunay

M.S., Electrical and Electronics Engineering, Boğaziçi University, 2020

Submitted to the Institute for Graduate Studies in
Science and Engineering in partial fulfillment of
the requirements for the degree of
Master of Science

Graduate Program in Electrical and Electronics Engineering
Boğaziçi University

2020

ACKNOWLEDGEMENTS

I would like to thank my supervisor Assist. Prof. Heba Yüksel for her continuous support and guidance. I am deeply grateful for her excessive tolerance and assistance. I thank my friends for their encouragement, tolerance and support during my thesis. Last but not least, I would like to thank my wife and family for their love and encouragement.

ABSTRACT

HOST-TO-HOST TCP/IP CONNECTION OVER SERIAL PORTS USING LI-FI FOR INTERNET CONNECTION

Li-Fi(Light Fidelity) is a new technology used in communication, it uses existing light to send data and cannot be detected by human eyes. Especially for military purposes, which require secure signals, this technology is used. The aim of this project is to enable a host-to-host TCP/IP connection over serial ports using Visible Light Communication. In order to check the status of network connections between two computers, the ping tool is used. Ping checks whether it's possible to reach one computer from another. Moreover, frequency dependence of the communication is tested.

ÖZET

LI-FI ARACILIĞIYLA İNTERNET BAĞLANTISI İÇİN SERİ PORTLAR ARASI TCP/IP BAĞLANTISI KURULMASI

Li-Fi(Light Fidelity), yeni bir teknoloji olup, gelecekte popüler olacak teknolojilerin başında gelmektedir. Günlük hayatımızda kullanılan ışık kaynakları kullanılarak haberleşme sağlanır ve insan gözü bu haberleşmenin farkına varmaz. Özellikle askeri amaçlar gibi, data güvenliği önemli olan alarda kullanılır. Bu tezde de, bilgisayarların seri portları kullanılarak, internete fiziken veya kablosuz bir şekilde bağlı olmayan bilgisayarın, internete bağlı olan bilgisayar ile ışık aracılığıyla haberleşmesidir. Bu haberleşme internetsiz bilgisayardan atılan bir ping'in ışık ile ikinci bilgisayara gidip, orada anlamlandırılıp internete bağlanmasıdır. Ayrıca bu haberleşmenin frekans ile değişimi de incelenecektir.

TABLE OF CONTENTS

ACKNOWLEDGEMENTS	iii
ABSTRACT	iv
ÖZET	v
LIST OF FIGURES	vii
LIST OF ACRONYMS/ABBREVIATIONS	x
1. INTRODUCTION	1
2. LITERATURE SURVEY	3
2.1. History of Li-Fi	3
2.2. Li-Fi Researches	3
2.3. TCP/IP 4 Layer Definition	4
2.4. Theory	5
2.5. Communication Standards	8
2.6. Li-Fi Applicaiton Areas	9
3. DESIGN AND EVALUATION	11
3.1. HARDWARE DESIGN	11
3.1.1. Theory of Operation	11
3.1.2. LED Characteristics	12
3.1.3. Parallel-to-Series Conversion	13
3.1.4. Transmitter	15
3.1.5. Receiver	18
3.2. SOFTWARE DESIGN	20
3.2.1. Object Oriented Programming	21
4. EXPERIMENTS AND RESULTS	23
4.1. Experiment	23
4.2. Results	29
4.3. Limitations with Li-Fi	30
5. CONCLUSION	32
REFERENCES	33

LIST OF FIGURES

Figure 1.1.	Simple Li-Fi System	1
Figure 2.1.	Four Layer TCP/IP Structure	5
Figure 2.2.	Layer Structure	6
Figure 2.3.	TCP/IP Data fragmentation	7
Figure 2.4.	Layer Structure	7
Figure 2.5.	Li-Fi in deep water	10
Figure 2.6.	Attocells application in a meeting room	10
Figure 3.1.	Simple Li-Fi System	11
Figure 3.2.	Parallel communication	13
Figure 3.3.	Series communication	13
Figure 3.4.	General Input Output Structure of USB/UART Converters	14
Figure 3.5.	Example in serial communication	15
Figure 3.6.	Power LED	15
Figure 3.7.	Transmitter circuit design	16

Figure 3.8.	Simulation output for current through a power LED	17
Figure 3.9.	Transmitter part of the circuit	17
Figure 3.10.	LDR - Light dependent resistor	18
Figure 3.11.	Receiver circuit design	18
Figure 3.12.	Receiver circuit design	19
Figure 3.13.	Receiver part of the circuit	20
Figure 3.14.	4 pillars of Object Oriented Programming	21
Figure 3.15.	Object Oriented Programming Diagram	22
Figure 4.1.	Soldered circuit during data transmission	23
Figure 4.2.	PC1 and PC2 connected to the circuits via USB ports	24
Figure 4.3.	Communication of 2 circuits	25
Figure 4.4.	External Power Supply and Oscilloscope	25
Figure 4.5.	High baud rate:9600bps receiving signal is not meaningful (yellow line: receiver input, blue line: transmitter output)	27
Figure 4.6.	Low baud rate: 200bps, receiving signal is same with transmitted signal (yellow line: receiver input, blue line: transmitter output) .	28

Figure 4.7. Serial communication between 2 circuits, "Data from serial" is the received data 29

Figure 4.8. Serial communication between 2 circuits, "Data to serial" is the transmitted data 30

Figure 4.9. Data From TUN Device 30

LIST OF ACRONYMS/ABBREVIATIONS

Abbreviations in alphabetical order

2D	Two Dimensional
3D	Three Dimensional
Bps	Bits Per Second
LED	Light Emitting Diode
LDR	Light Dependent Resistence
Li-Fi	Light Fidelity
ICPM	Internet Control Message Protocol
IoT	Internet of Things
IP	Internet Protocol
OOP	Object Oriented Programming
RF	Radio Frequency
RX	Receiver
TCP	Transmission Control Protocol
TX	Transmitter
UART	Universal Asynchronous Receiver/Transmitter
UDP	User Datagram Protocol
USB	USB Universal Serial Bus
UTF-8	Unicode Transfer Format with 8 bits
VLC	Visible Light Communication

1. INTRODUCTION

Wireless usage is exponentially growing, although existing radio frequency communication spectrum is very limited [1]. One of the best solution to extend bandwidth of the communication is visible light communication (VLC). Using visible light technology comes with new advantages [2]:

- License free bandwidth
- 100s of THz, higher bandwidth than RF
- Simple front end devices
- Possibility for integration into the existing lighting infrastructure.

In the near future, visible light communication (VLC) seems to take place of Wireless Fidelity, both are bidirectional, high-speed and fully networked wireless communication technology. This new technology can be a complement to RF communication (Wi-Fi or cellular networks), or even a replacement in contexts of data broadcasting. Main difference between these technologies is that Visible light communications can work both for communication and illumination purposes, because LEDs switch on and off at a very high rate too quick, so it can not be noticed by the human eye. Also, the light waves cannot penetrate walls which makes a much shorter range and more secure from hacking than Wi-Fi technology.



Figure 1.1. Simple Li-Fi System

In this project, the objective is to enable a host-to-host TCP/IP connection over serial ports using visible light communications for Internet connection. This technology

is used in last years and has lots of applications. However this project is different than existing ones in terms of that the computer is connected to Internet without Wi-Fi or ethernet cable, but via light. The Figure 1.1 summarizes the project setup, although PC1 does not have an Internet connection, it can connect Internet via VLC. 2 circuits are designed and these circuits communicates via light and are connected to USB ports of PCs. A virtual tunnelling device is used to reach Internet on PC2.

2. LITERATURE SURVEY

2.1. History of Li-Fi

Although it is known as a new technology, Alexander Graham Bell invented photophone in 1880, which transmits speech (data) using a beam of light. Then Japanese researchers worked on communication through visible light in 2000. They used LED(light emitting diodes) as the transmitter and an indoor communication system with overhead lighting as a medium [3]. After this time, lots of researchers have studied the VLC technology.

Harald Haas from the University of Edinburgh invented the Li-Fi term in 2011, by flickering the light from a single LED. He noticed that he could transmit far more than a 2G/3G cellular tower. Then he recorded that 224 Gbps (gigabits per second) which is 2 games of 10GB each can be downloaded every single second. He joined a company named pureVLC, but later it was renamed as "pureLiFi" that was producing LiFi products and integration with existing systems, which uses LED technology [3].

2.2. Li-Fi Researches

There are some existing researches on combination of VLC and Internet connection. Hao Ma et al. explain how to use VLC as a download link [4]. They integrate indoor visible light and power line communication. However this is just unidirectional communication. Another research done by Yingjie He et al. show how to use VLC for real-time audio & video transmission [5]. This is again unidirectional communication and there is nothing about internet connection. Chia-Wei Chen et al. use VLC for IoT applications [6]. VLC over UART system is used in that experiment which is similar to our experiment as design perspective. However, it doesn't include any internet connection. In our experiment, we provide a host-to-host TCP/IP connection over serial ports using visible light communications.

Sandeep Kumar Jain made researches on Li-Fi in his article "A Review Paper on Li-Fi Technology" [7]. Even this article cites to Harald Haas because the technology is new and there is not much information about Li-Fi. Harald Haas compares Li-Fi with 5G technology in one of his articles [8]. He explains similarities between 5G and Li-Fi such as both operate in short range than 2-3-4G and faster than these old technologies in terms of data transfer. Haas supports using Li-Fi in our daily life because of limited bandwidth of RF spectrum [8]. He is also working on combining Internet technology into Li-Fi like our project, but this project differentiate from Haas in terms of adding host-to-host communication in it.

The transmitter and receiver circuit design used in the project is explained in detail in the article [9]. However, in [9], the design is only used in a unidirectional way to jeopardize the security of the Li-Fi system by detecting the signal though detecting power fluctuations at the transmitter side during communication [9]. In our experiment, bidirectional transmitter/receiver pair is used to transmit data from a serial port to a device so that the processor receives the information without using the Ethernet connection.

2.3. TCP/IP 4 Layer Definition

There are 4 main layers in communication systems.

Application layer is the top level of the model. When two applications create a connection by using any communication type, the application layer prepares a request or an answer which comes from the transport layer.

Transport layer is the 3rd layer of the model, between the application and the Internet layer. This layer enables devices on both source and destination hosts to create a conversation. Main protocols at that level are TCP (Transmission Control Protocol) and UDP (User Datagram Protocol).

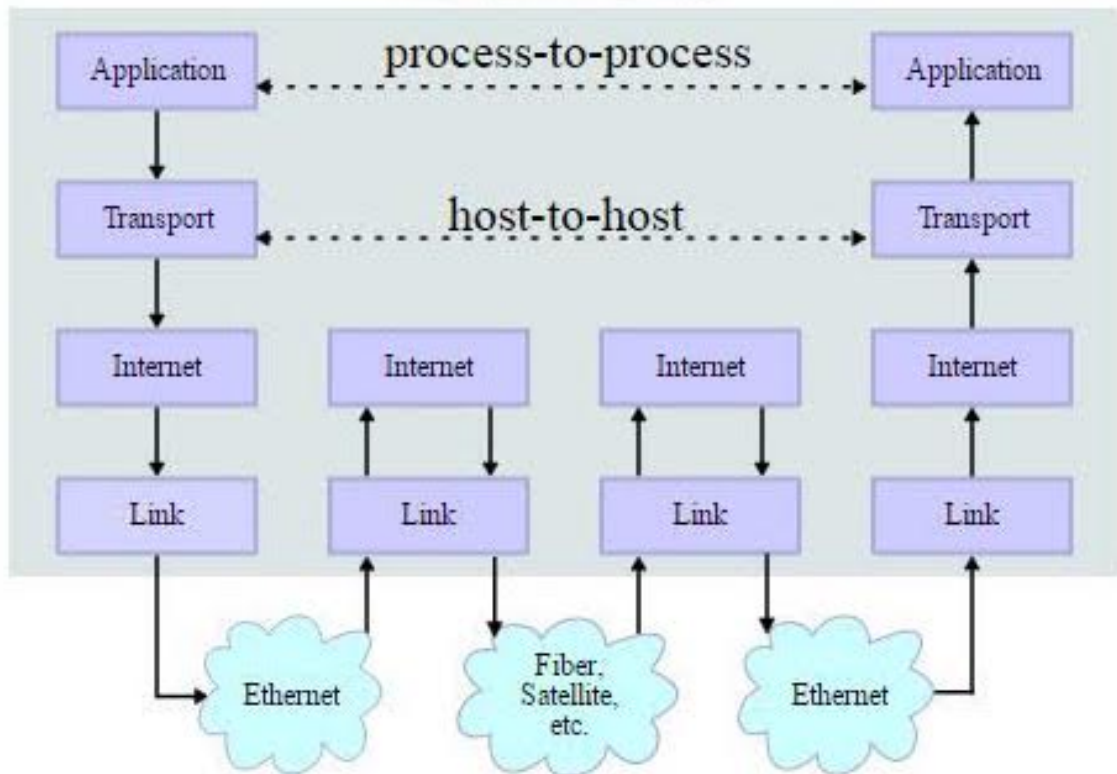

Figure 2.1. Four Layer TCP/IP Structure

Internet layer is placed below the Transport layer and above the Network layer. Its role is providing hosts to insert packages into any network. Main protocols at that level are IP (Internet Protocol), ICPM (Internet Control Message Protocol), and ARP (Address Resolution Protocol).

The first layer on the bottom is the Network layer which includes how data is physically transmitted through the network, including electrically or optically or directly to the medium such as coaxial cable or optical fiber cable or copper cable.

2.4. Theory

Since the objective of this project is to enable a host-to-host TCP/IP connection over serial ports using visible light communications, it builds upon the theory of how layers of connection are structured [10].

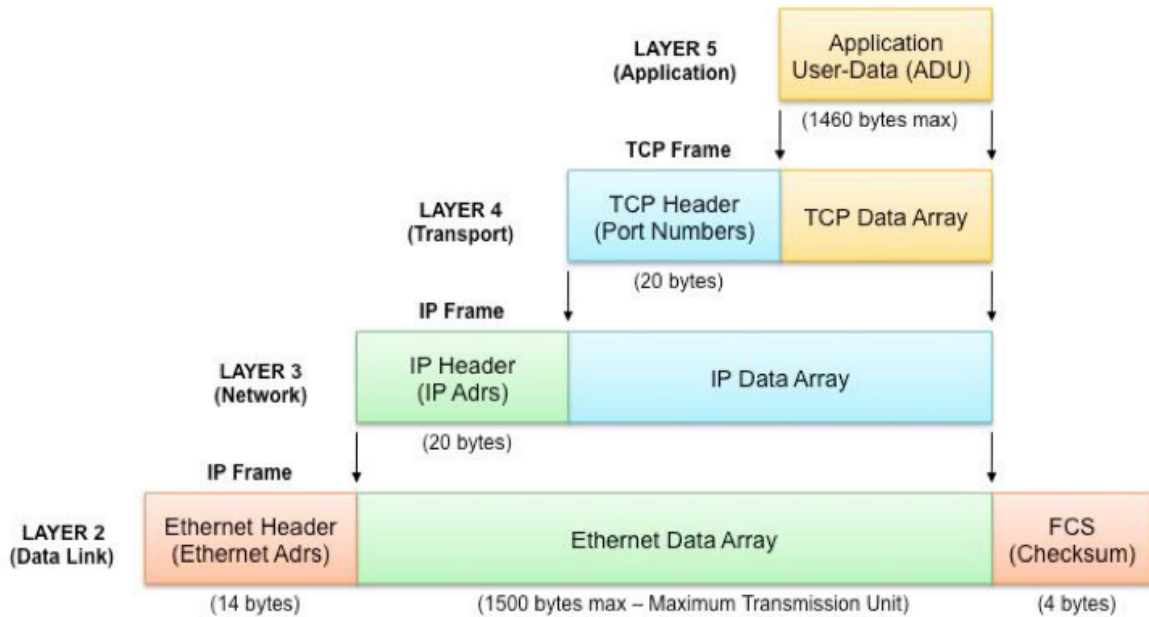

Figure 2.2. Layer Structure

Transmission Control Protocol (TCP) is a connection oriented protocol and occurs in the transport layer. TCP helps network layer to deliver data by dividing data into packages. TCP manages the flow control by sending or accepting packages from the Internet layer. If any problem occurs during transmission like data loss, TCP creates a retransmission of these distorted packages to provide zero-error communication [11].

On the Internet layer, the Internet Protocol(IP) is another principal communication protocol. IP has routing functions and this provides the packages to be delivered from source host to the destination host based on IP addresses. So, IP information is inserted to the packages for both source and destination parts.

TCP/IP is not only the basic communication language of the Internet but also for the private network, Intranet. When a user provides a direct address to the Internet, TCP/IP program is automatically copied by the computer to get or send data from other computers that have the same protocol.

Lastly, it can be seen that TCP/IP is a two layer program. They are transport and Internet layers. TCP is the higher layer and manages the message delivery in

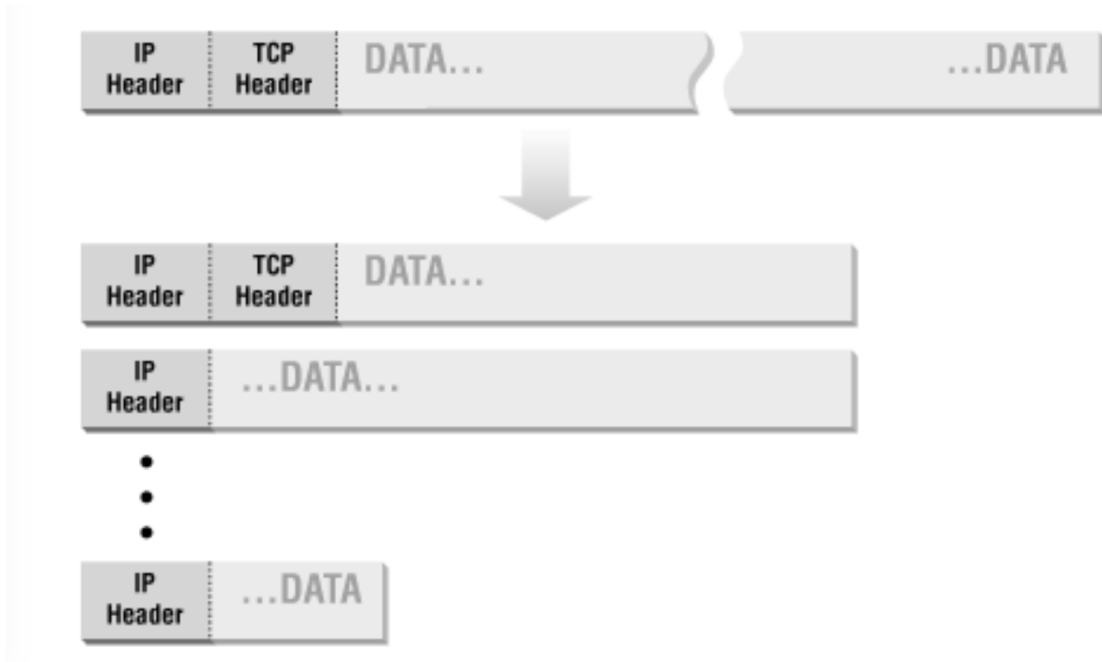

Figure 2.3. TCP/IP Data fragmentation

packages such that the network access layer can handle the hardware delivery. IP is the lower layer and gets to the correct destination, because it handles the address part of each packet [11].

In our experiment, these 4 layers will not be used, because source and destination host will initially be connected via hardware link, so the project will be host-to-host connection, because communication will be at that level.

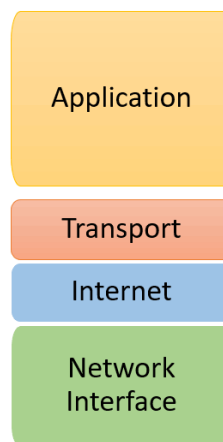

Figure 2.4. Layer Structure

In real life, a network device generally has a physical port, called the Ethernet port. This port is used to send or receive packages via cable. However, a virtual device is used for this purpose which is created by an engineer called Maxim Krasnyansky. This device is called TUN, coming from the word "Tunnel" (See Appendix A). The device is virtual and managed on kernel. The kernel can not understand that it is virtual or not, once it is coded and activated on kernel, the device sends data to this virtual one if it exists.

2.5. Communication Standards

Most relevant standards for our experiment are the followings:

- **Internet Protocol:** It is a method that on the Internet the computer sends data to other. Every single personal computer has a unique IP which is exactly different than other PC IPs [12].
- **Transmission Control Protocol (TCP):** It is used for connection-oriented transmission which exists in the transport layer of our 4 layer model [13].
- **Unicode Transfer Format with 8 bits (UTF-8):** It is a term for encoding Unicode characters as a variable number of 1 to 4 octets. Integer values that are assigned to the Unicode characters are main dependency for number of octets. It is an efficient format that can define each US-ASCII character between U+0000 and U+007F in a single octet [14].
- **Base64:** It is a term for encoding binary data by treating it numerically and converting it into base64 representation [15].
- **Serial Asynchronous Communication:** It is the standard serial data communication for computers and ports such as PS/2 computers(mouse, keyboard). Data is sent as sequential individual bits and destination part assembles these bits into the original character. At both the transmitting and receiving ends, error checking, data rate, and start & stop bits are predefined. This standard is already defined in RS 232.

2.6. Li-Fi Application Areas

Today, there is a huge demand on wireless devices, which causes the high number of applications and users. In order to respond to this demand, new technologies are needed, so Li-Fi is an excellent technology. The visible light spectrum is 10,000 times wider than radio frequency spectrum [16].

One of the main advantage of this technology is having high data rates. As it is explained in the previous section, 224 Gbps is reached in the lab environment. Also, visible light spectrum is free for everyone and unlicensed which makes it cost effective [16].

Other advantages for Li-Fi technology are efficiency, availability, safety and security. First of all, circuits are simple and easy to produce. It is secure, because it can not pass through walls or any other opaque materials. Transmission can not be detected by human eyes if the system has enough high blinking frequency [17].

However, this advantage can be taken as a disadvantage, it means communication can not be occur if there is any opaque material between the transmitter and receiver. So for any reason, communication can be lost for blockages.

Li-Fi applications can be used where RF technology is restricted because of electromagnetic interference; airplanes, hospitals and nuclear power plants. Also, Li-Fi is useful for daily issues which need short distance and direct communication like traffic management, underwater communication or outdoor Internet connection. This technology is still being improved in laboratory environment and for military purposes because it can not be detected with existing devices [16]. In our thesis, we will combine Li-Fi with Internet connection and create a hybrid model.

Optical attocells are another possible application for Li-Fi. The main aim for this application is to cover rooms with LEDs that have Li-Fi technology in it [16].

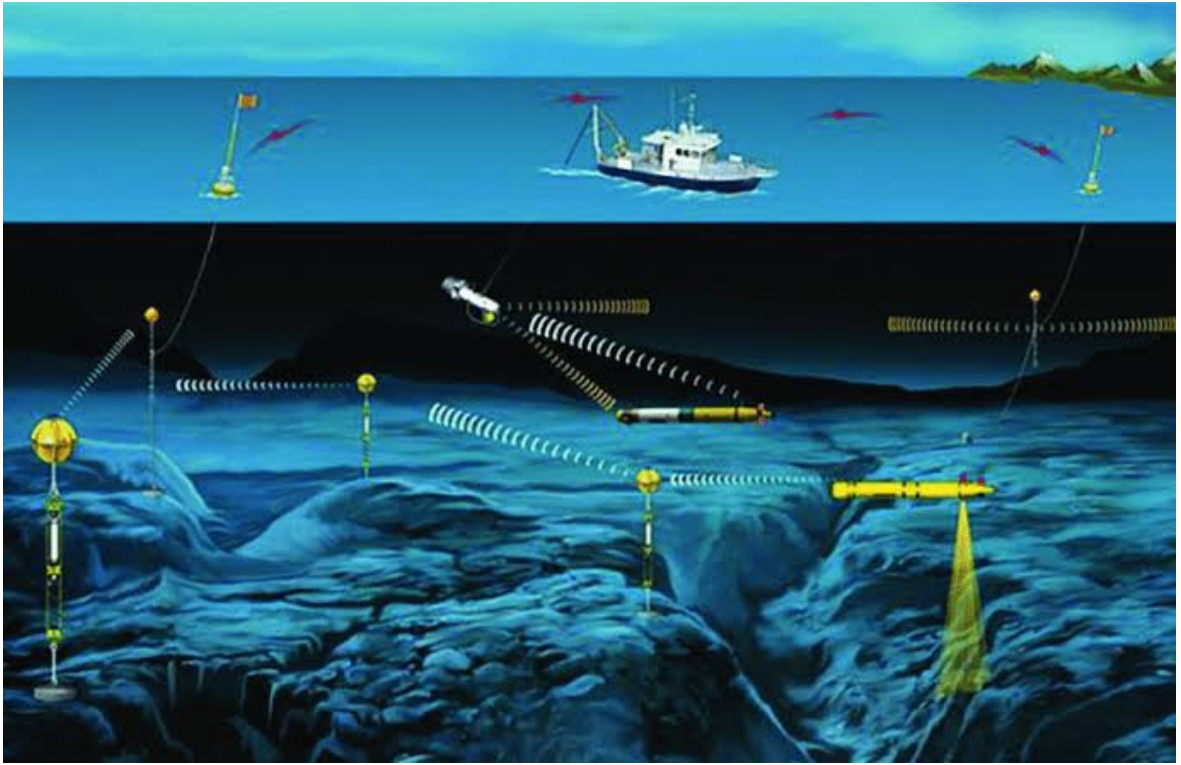

Figure 2.5. Li-Fi in deep water

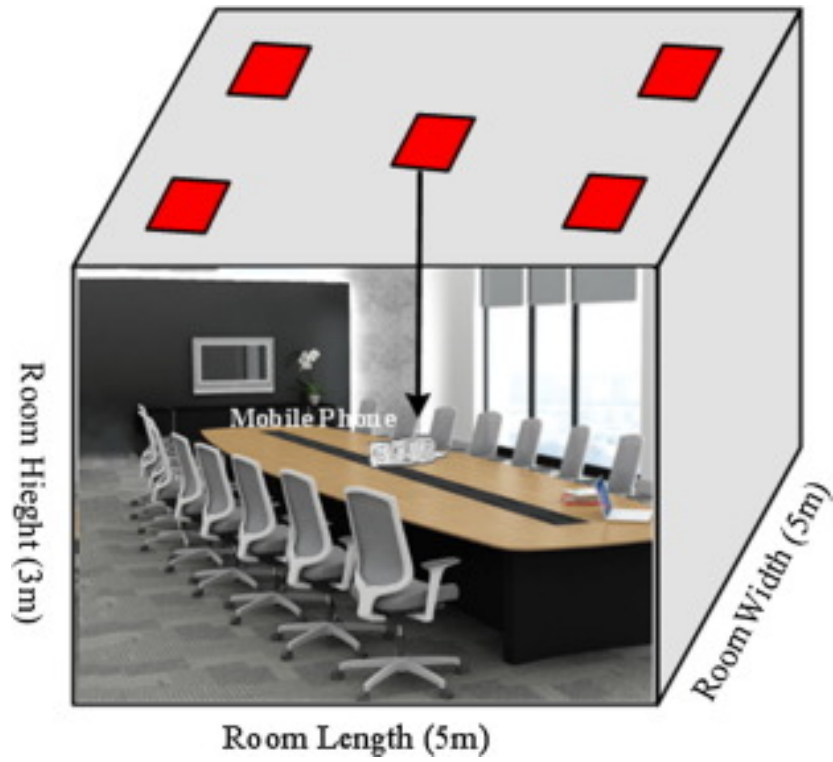

Figure 2.6. Attocells application in a meeting room

3. DESIGN AND EVALUATION

Since the objective of this project is to enable a host-to-host TCP/IP connection over serial ports using visible light communications, it requires both hardware and software design work.

3.1. HARDWARE DESIGN

3.1.1. Theory of Operation

Since the concept of communication involves a sender and a recipient, every communication system requires a transmitter and receiver. In this project, visible light communication will be executed bidirectionally. There will be two transmitter-receiver pairs. In our thesis, data will be sent from one PC and will be read on another PC. A simple Li-Fi system is shown in Figure 2.1

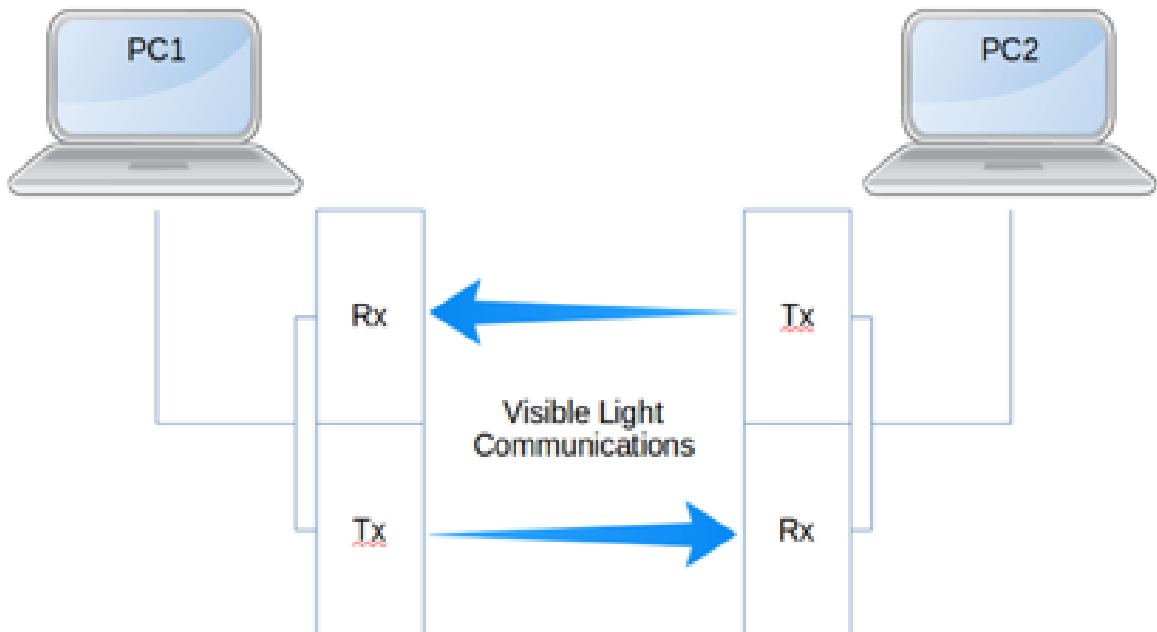

Figure 3.1. Simple Li-Fi System

Communication on the system is achieved through visible light. The system has

2 identical circuits, both having the receiver and transmitter parts on them so acting as transceivers. These circuits are connected to different PCs via USB ports. They receive energy from the PC but it is not enough for LEDs to emit light so an external power supply is needed.

The user writes data (which is ping here) on the terminal and sends it through the USB port to the transmitter. The transmitter sends this ping to the receiver by blinking which is not detected by human eyes. This received data is shown on the other PC which is connected to receiver part.

Data is sent to check that there is an Internet connection on the second PC. Once this operation occurs, a second PC sends data to the circuit again and it re-sends data to the first PC and the user can get an internet ping result on the first PC which does not have any physical Internet connection.

3.1.2. LED Characteristics

LEDs which are solid state elements are the key elements for VLC. They have some disadvantages on the development of commercial VLC systems [18]. In general, white light LEDs are commonly used in the applications. Phosphorescent and multi-color (RGB) LEDs are the main two types used [19]. The phosphorescent type consists of a blue LED chip plus a yellow phosphor layer. However, the other type consists of red, green and blue chips (hence RGB). The advantage of the phosphorescent type is having cost-efficient installations, because of its simple design. However it has a narrow modulation bandwidth, given the slow response time of the phosphorescent material [19].

On the other hand, it can be demonstrated that the bandwidth can be enhanced by an order of magnitude of about 20 MHz by suppressing the phosphorescent portion of the optical spectrum with the aid of a blue filter at the receiver end [20]. In contrast, white-light RGB-type LEDs enable three individual color channels, each providing

approximately 15 MHz bandwidth. By using three drivers in parallel, wavelength-division multiplexing (WDM) can be realized. However, the advantage of an increased aggregate data rate is achieved at the expense of higher costs [19]. In our experiment, white light LEDs are used.

3.1.3. Parallel-to-Series Conversion

Personal computers send out data from their Universal Serial Bus (USB) ports. However, USB ports are parallel communication ports and they send multiple bits at a time. To use this parallel data in serial form, a parallel-to-series (P/S) converter is needed.

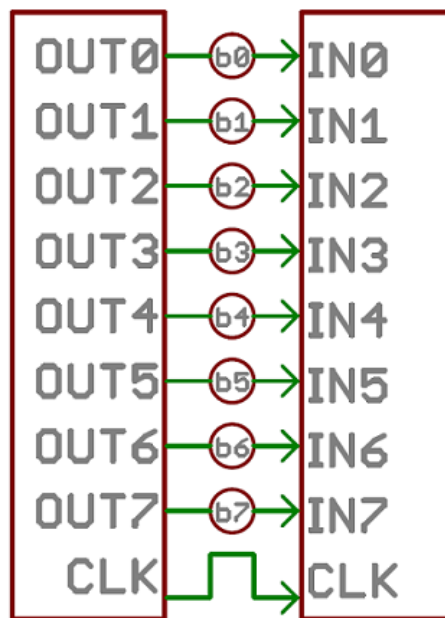

Figure 3.2. Parallel communication

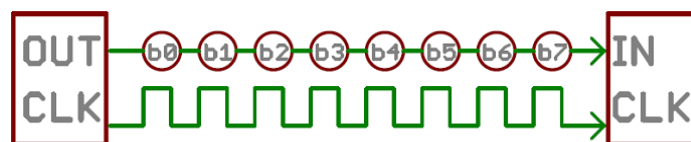

Figure 3.3. Series communication

Universal Asynchronous Receiver/Transmitter(UART) converter is the easiest way to convert serial data into parallel data. The general input output structure of USB/UART converters is shown in Figure 2.4.

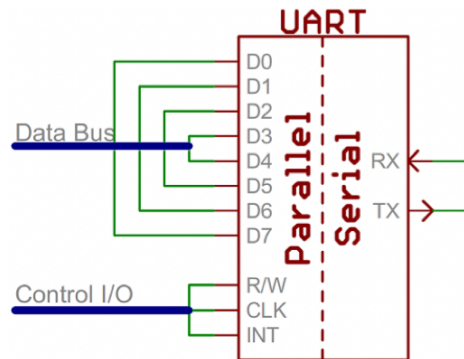

Figure 3.4. General Input Output Structure of USB/UART Converters

Ensuring robust and error-free data transfers is really crucial in data transfer. The asynchronous serial protocol has a number of built-in rules for it. These rules are synchronization bits, parity bits and baud rate.

Another important think is using exactly the same protocol on both devices. Although it is so configurable, same protocols are used on both devices serial line.

Data can be sent with different speeds, called baud rate. Bits per second is used in expressing how long it takes to transmit a single bit in seconds. Baud rate can be any value depending on the system. One and only requirement is having the same baud rate on both devices. One of the more common baud rates, especially experimenting where speed is not critical, is 9600 bps, which will be used in our experiment. Other widely used baud rates are 1200, 2400, 4800, 19200, 38400, 57600, and 115200.

Start and stop bits are the synchronization bits which are two or more special bits transferred with each chunk of data. Functionalities come from the names. The start bit is used at the beginning of the packet and the stop bits are used at the end of a packet. The start bit is always a single bit, but the stop bits can be configurable, one or two. An idle data line determines the start bit which is going from 1 to 0, on the other hand, the stop bit(s) transitions back to the idle state by keeping the line at 1.

Another bit, which is optional, is the parity bit. It enables low level error checking.

In serial communication, there are odd and even parity bits. Lets assume the even parity will be used, then the sum of all the bits in the communication must be even. If the sum of all bits is odd, then this parity bit will be set to 1 to make the sum even. Parity is an optional feature and is not used so much if the environment is not noisy. However, it has disadvantage on the communication. It slows down the data transfer rate because it increases the number of bits. Also, both sender and receiver devices need to interpret the data and check if the parity bit is correct or not. A framing example in serial communication is shown in Figure 2.5.



Figure 3.5. Example in serial communication

3.1.4. Transmitter

Power LEDs are the key component in the transmitter part of the system. They emit light waves through the receiver unit. Power LEDs are chosen because they can switch on and off very fast and consume low power.



Figure 3.6. Power LED

According to the circuit design, when the digital signal at the input terminal is high, power LEDs emit light waves and switch on; when the input terminal is low, they switch off and can not emit light waves. This approach is specifically chosen, because when there is no communication between the receiver and transmitter, we have an idle position, LEDs must illuminate the environment. The design ensures this situation, power LEDs are on and illuminate the room when it is idle, because serial ports are always high when they are idle.

USB/UART converter is used in this project in order to send data from the PC to the circuit or vice versa. However, it can only supply current through the TXD output up to 10mA which is not enough for three power LEDs, even though this current is amplified. To overcome this situation, an external power supply is connected to the power LEDs. Therefore, other than three transistors connected to the power LEDs, one more transistor is used in the design. It is used as a switch to activate or deactivate the other three transistor. The emitter of this extra transistor is connected to the bases of the other three transistor. Final design of the transmitter circuit can be seen in Figure 2.7.

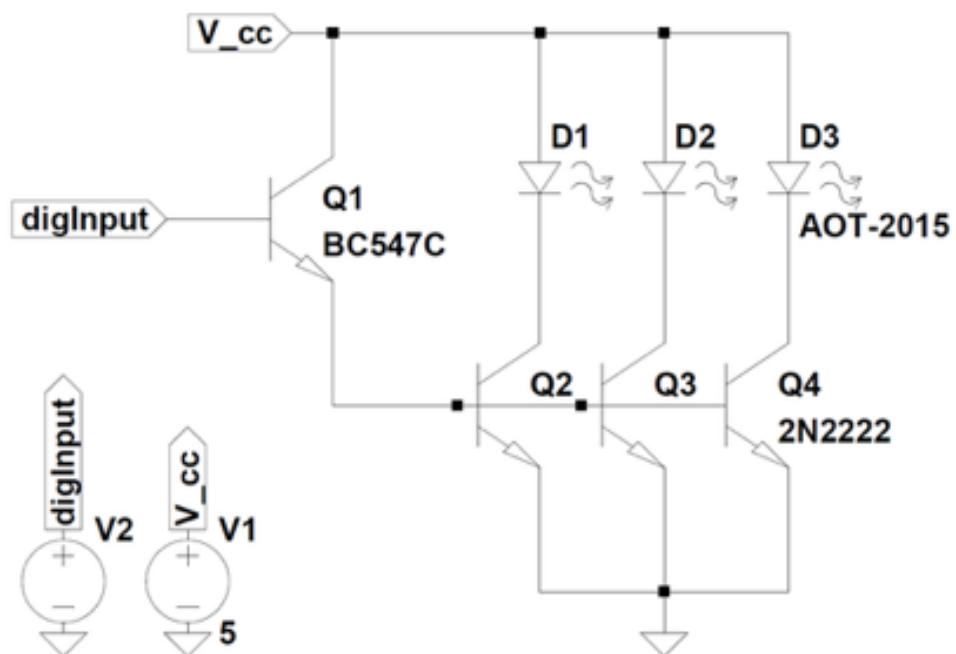

Figure 3.7. Transmitter circuit design

According to the Figure 2.7, when the digital signal is low, Q1 is in the cut-off region. Therefore, with no current into their base, other transistors are also in the cut-off region and LEDs do not emit light. When the digital signal is high, Q1 transistor is in the saturation region and supplies current to the other transistor bases. With this high base current, other transistors are also in the saturation region and draw current through the power LEDs.

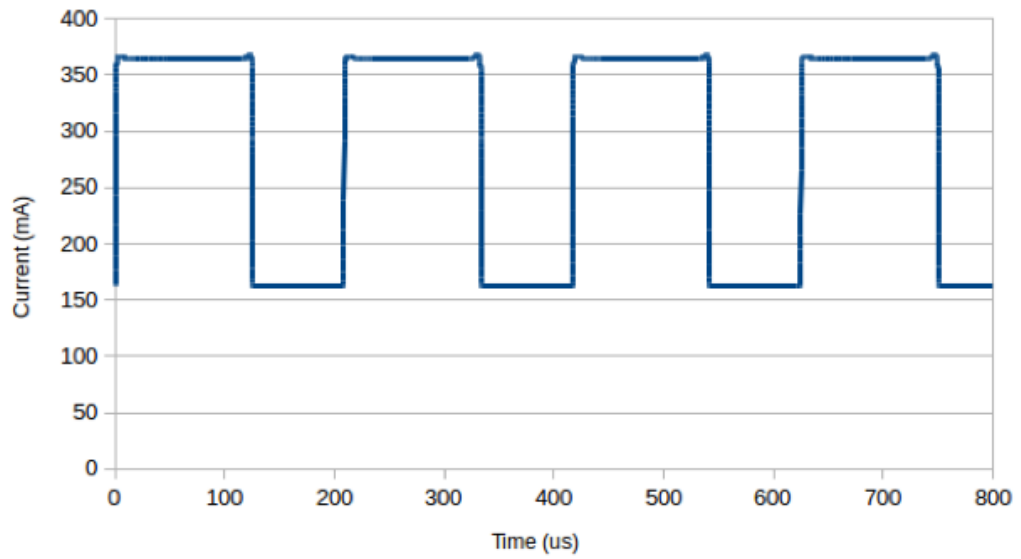

Figure 3.8. Simulation output for current through a power LED

The circuit is soldered on a pertinax plate, after the all transistors and other components are tested.

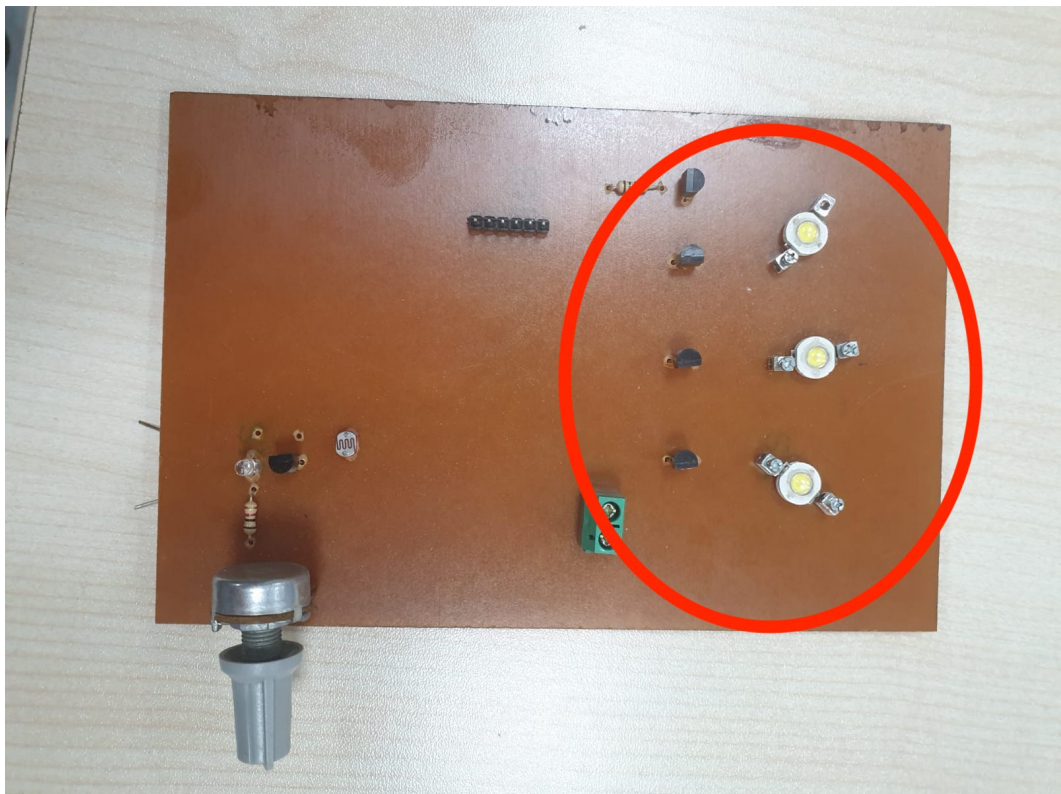

Figure 3.9. Transmitter part of the circuit

3.1.5. Receiver

Light dependent resistors (LDR) are key components on the receiver part of the circuit because LDR resistivity is sensitive for the light falling onto its sensor.



Figure 3.10. LDR - Light dependent resistor

Output of the receiver part is connected to the collector of the transistor. Similar to the transmitter part, this transistor is used as a switch, not as an amplifier. Resistance of it determines the state of the transistor. LDR is connected between the base and emitter part of the transistor, which will have active role on the voltage difference between the base and emitter of the transistor.

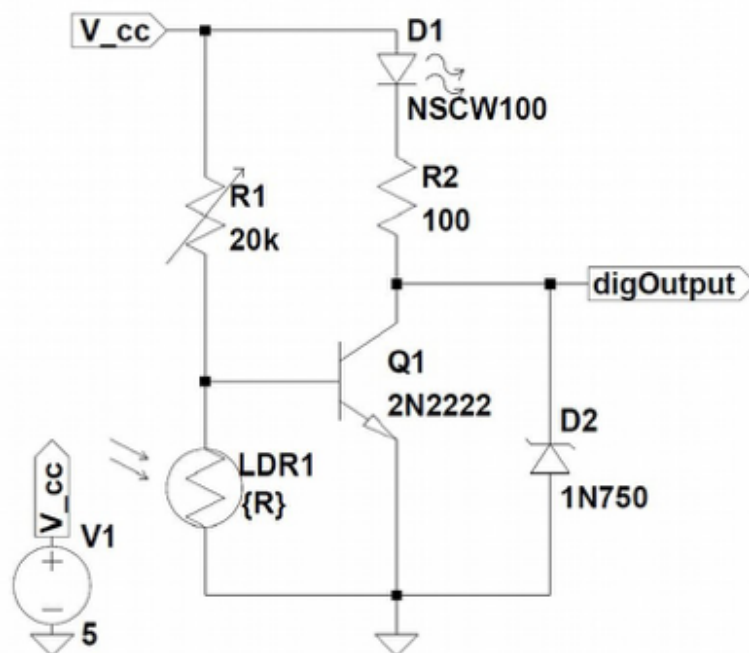

Figure 3.11. Receiver circuit design

If there is an illumination from the transmitter LEDs, then the LDR resistance falls and it decreases the base voltage and voltage difference between the base and emitter of the transistor. This is called the cut-off region. On the contrary, if the LDR is not illuminated, then the base voltage remains high and the transistor remains in the saturation region with very low voltage difference between the collector and emitter.

According to the design, the transmitted signal from the transmitter part of the circuit reaches the receiver part so when the digital input signal at the transmitter is high, LEDs emit light and the receiver circuit gives high output. On the contrary, if the digital input of the transmitter is low, then the transmitter output is low and receiver output becomes low.

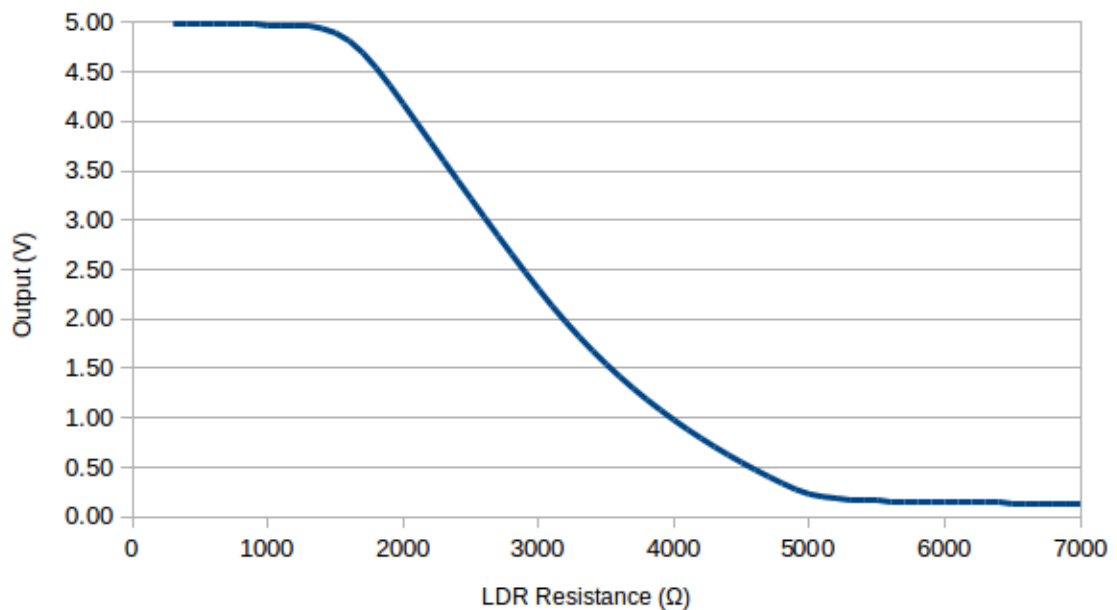

Figure 3.12. Receiver circuit design

The design was good in theory, however, the main problem is ambient lighting. LDR resistance is very sensitive to any illumination. To eliminate this situation, a potentiometer is used, which enables the user to adjust the voltage on the base of the transmitter. The potentiometer is placed in the circuit to create a voltage divider. When there is high ambient lighting, resistance of the potentiometer decreases to put the transistor in the saturation region. On the contrary, if the ambient lighting level is low, then the resistance of the potentiometer must be high to safely take the transistor

out of the saturation region. In order to protect the USB/UART converter from any electrical damage, a zener diode is used. Also there is one more LED in the design to determine if the potentiometer resistance is OK or not.

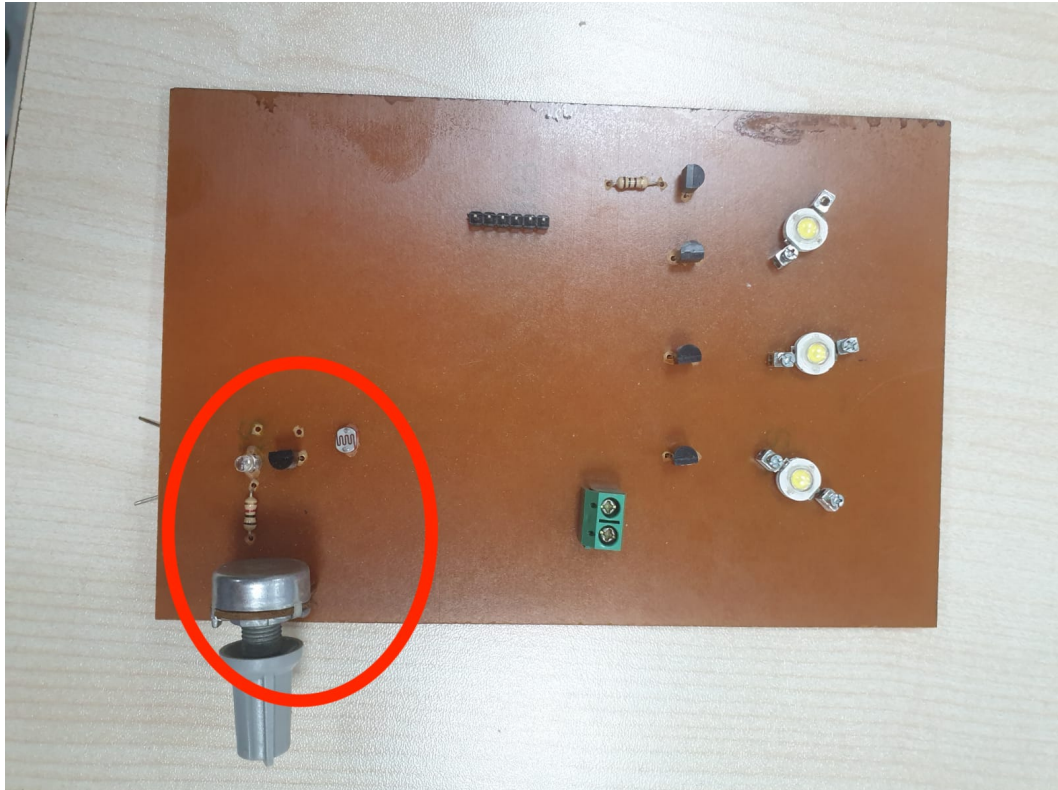

Figure 3.13. Receiver part of the circuit

The design in Figure 2.13 works correctly when the transmitter output is high, or the LEDs emit light, then the LDR resistance falls and the transistor is in the cut-off region, so the output voltage of the receiver is high. On the contrary, when the output of the transmitter is low or the LEDs do not emit light, then the LDR resistance increases and this brings the transistor to saturation. This means that output voltage of the receiver is low, as designed.

3.2. SOFTWARE DESIGN

After completing hardware designs for bi-directional VLC system, the next step is writing a software which will create the host-to-host communication via visible light. In this project, a TUN device is used and the code is written in an object oriented

programming method on Linux OS.

3.2.1. Object Oriented Programming

Object-oriented programming (OOP) is different from procedural programming language models in terms of using objects not actions. In OOP, classes include objects which interact with each other to develop any application or program [21]. Some examples of OOP languages are C++, PHP, Java, C#, Python etc. In the experiment, Python code will be written for the communication.

There are 4 main principals for OOP language:

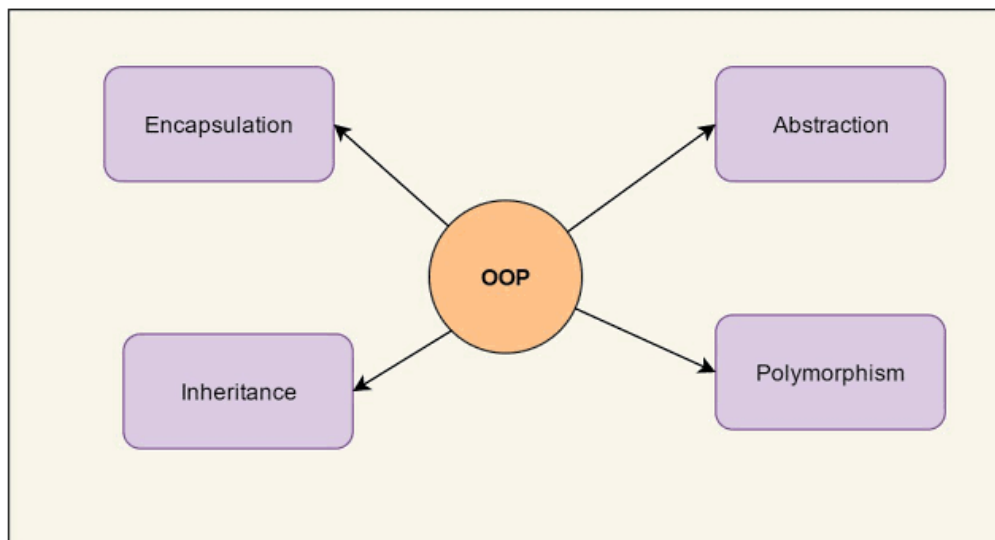

Figure 3.14. 4 pillars of Object Oriented Programming

- **Inheritance:** It inherits members from the parent class. Hierarchical classification is supported [21].
- **Abstraction:** It refers to simplicity. The code will just show the necessary information or features of the object, it does not consist of any other details [21].
- **Encapsulation:** It is another hiding feature. States, variables, parameters and other details are hidden from other objects, in contrary to the methods and events being explicitly shown to the other objects. This enables users to update the objects very easily and also this protects other existing objects [21].

- **Polymorphism:** It refers to having more than one form. It is very common to have one object but use it in very different events. Using different types of data provides this feature [21].

OOP has some advantages over Procedural Programming. OOP provides advance skills in terms of solving problems. The developer needs to think the structure of the computer firstly, then according to ability, start to solve the problem. However, OOP provides opportunity to the developer to solve the problem in the problem space. Also, the developer in procedural programming needs to create a link between the machine and the problem which will be solved. However, in OOP, the developer just thinks of the problem, not of the computer [22].

Object oriented programming has other benefits like it is more readable and understandable so it is more useful for teamwork of developers. Probability of error is low in OOP and maintenance is easier than Procedural Programming [22].

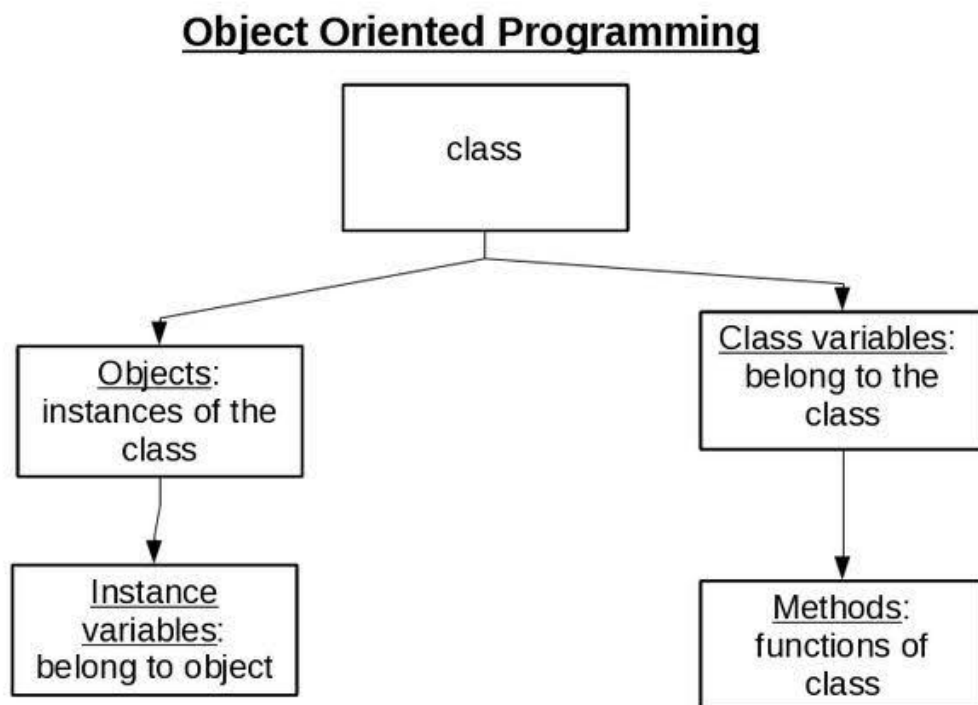

Figure 3.15. Object Oriented Programming Diagram

4. EXPERIMENTS AND RESULTS

4.1. Experiment

Before starting the experiment, PCs are connected to each other via a LAN cable so that a LAN network is connected between them. This enables the system to communicate on the same IP. After creating this environment, the circuit boards are connected to the PCs.

In order to create communication and see if it is correct or not, python code is written on object oriented programming. This code is run on both PCs in the terminal of Linux OS. Communication starts with writing ping command from the first PC that has no Internet connection. It directly sends data to the first circuit because python code links IP to the USB port. Therefore, when the data on the kernel is matched

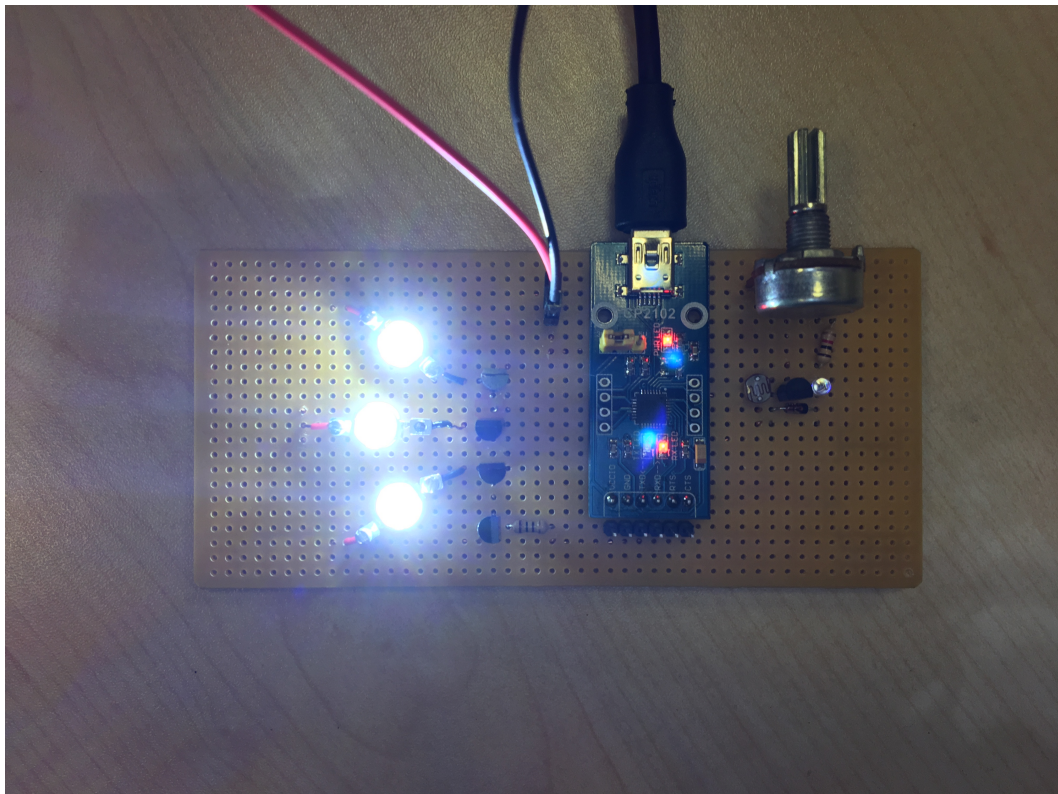

Figure 4.1. Soldered circuit during data transmission

with the code, data directly goes to the USB port. The transmitter part sends this command via light blinking to the second circuit. The second circuit receiver part gets it and sends it to the second PC via the USB port. This PC has active Internet connection. When the USB port gets matched IP command, it pings the network and when this communication is successful, the ping result is seen on the terminal of the second PC. This result is also sent to the first PC using the same operation.

For the transmitter part, the power comes from USB port of the computer but it is not enough for power LED component so external power supply is used for LEDs in Figure 3.4 .The transmitter LED creates a light sequence and the receiver code is activated when it gets the first bit as high. High and low voltages indicate that if the LED is active; high, if the LED is not active; low.

Each character is shown as an 8-bit binary code. There is one starter bit and one stopper bit. So a 10-bit binary code is sent from the LED and the LDR detects it and creates a current through the resistors and this current goes to the second PC

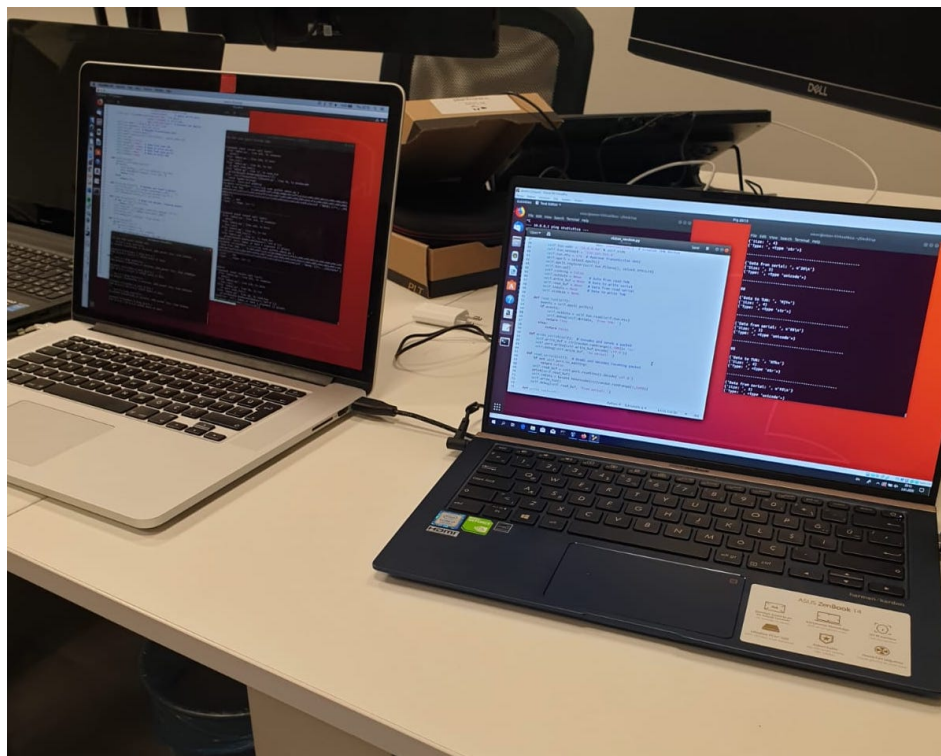

Figure 4.2. PC1 and PC2 connected to the circuits via USB ports

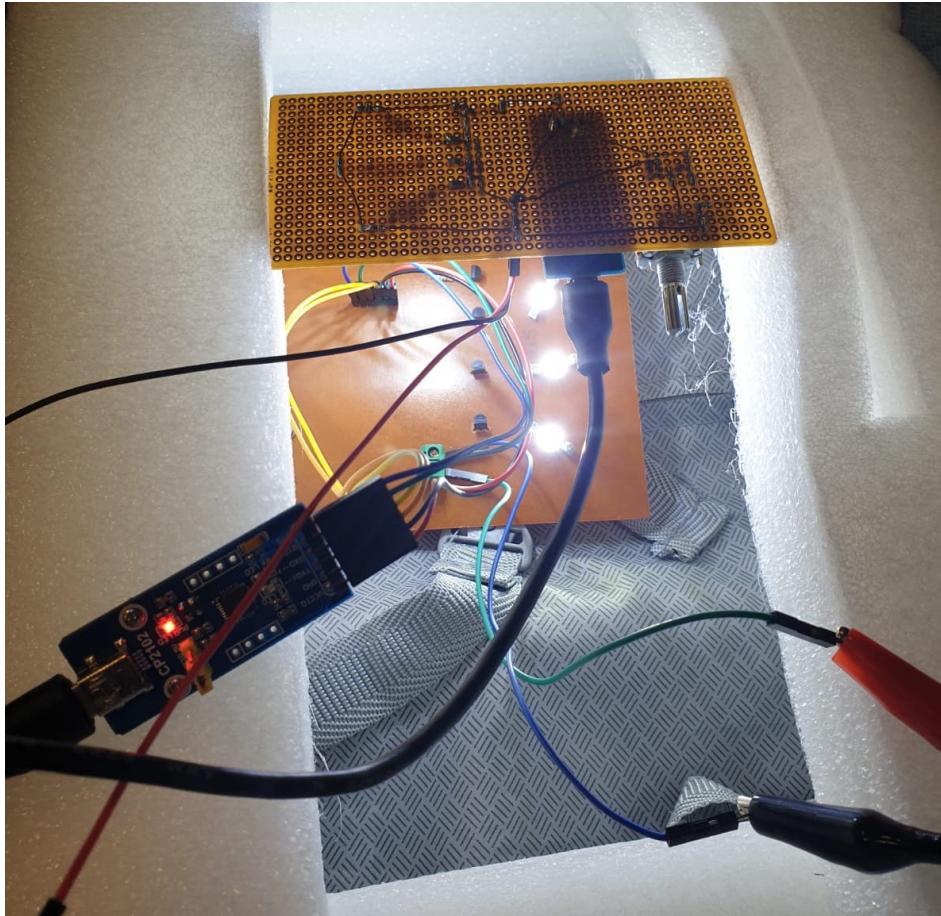

Figure 4.3. Communication of 2 circuits

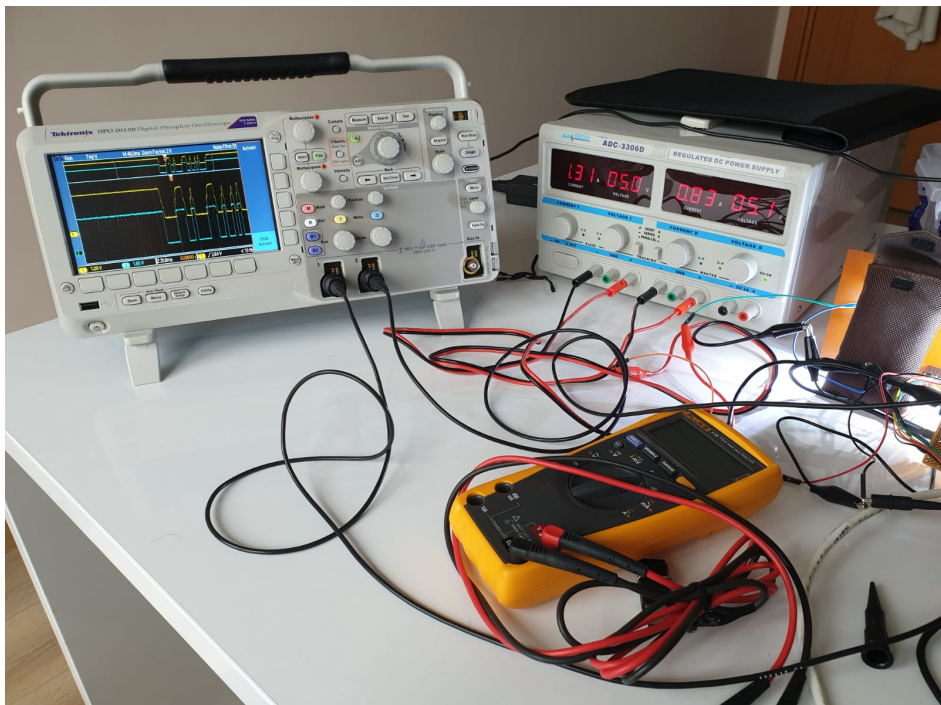

Figure 4.4. External Power Supply and Oscilloscope

terminal via the USB port. Initially, an IP environment is created and this is written in the code. So, when any data comes with this IP, the terminal detects it and sends it to the Internet. Whether the ping is successful or not, the results come back and are seen on the first PC.

For example in the setup, if you press A button from the computer on the transmitter side which is "01000001", data is send as "1010000011" with starter and stopper bit. When the receiver gets the first high bit, it starts to read the remaining 8-bit and wait the last bit as high again. After completing this action, it converts this 8-bit code to a character and writes the serial portal as "A".

In our case, Li-Fi communication is tested with 2 different data. Firstly a random string is sent to PC2 and it is reflected to PC1 via light. This part is successful. In order to get Internet connection, ping tool is used but it needs some more external codes to work. So by sending serial data to other PC, it is shown that data can be transmitted and can be interpreted on other PC and if "ping" can be interpreted via other codes which is possible, internet connection will be seen.

There were some problems on getting ping results because of network problems. So, initially some basic random digits have been sent from PC1 to PC2, then the same operation is repeated from PC2 to PC1. It was successful. Results were seen on the terminal of the PCs.

Another important part of this communication is speed of this communication. There is an important problem here, when the baud rate is high, there are some problems in reading the correct characters because components are not ideal. In Figure 3.5 receiver input for receiver circuit is crashed because of low respopnse time of LDR. Response time of Light Dependent Resistor (LDR) is much slower than photo-transistors, about 20ms. This makes hard to get a communication on 9600bps baud rate. In order to demo the system, the communication is tested and approved on 200bps baud rate. In Figure 3.6 receiver circuit input is exactly same with the transmitter output.

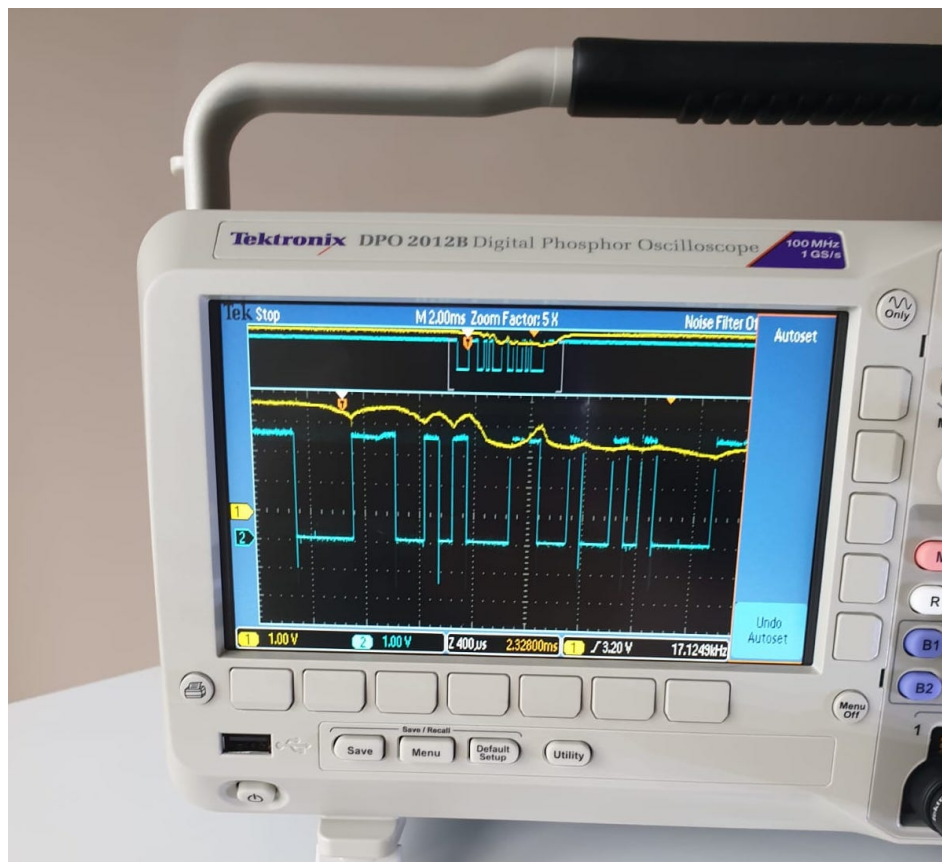

Figure 4.5. High baud rate:9600bps receiving signal is not meaningful (yellow line: receiver input, blue line: transmitter output)

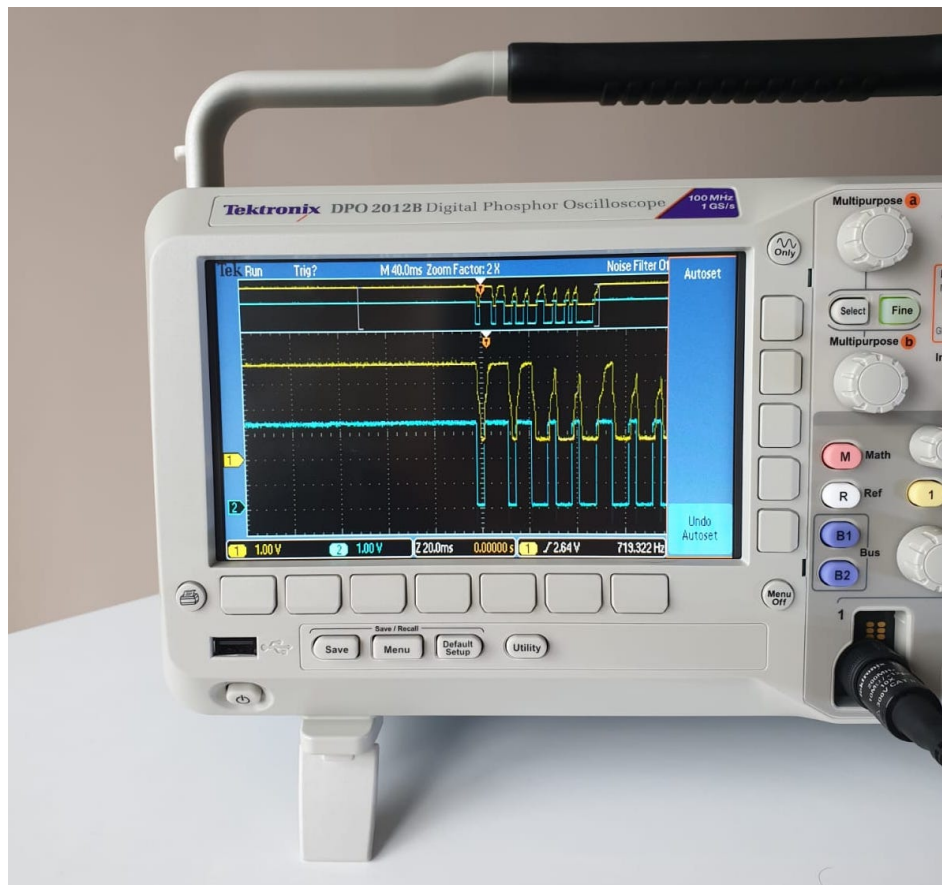
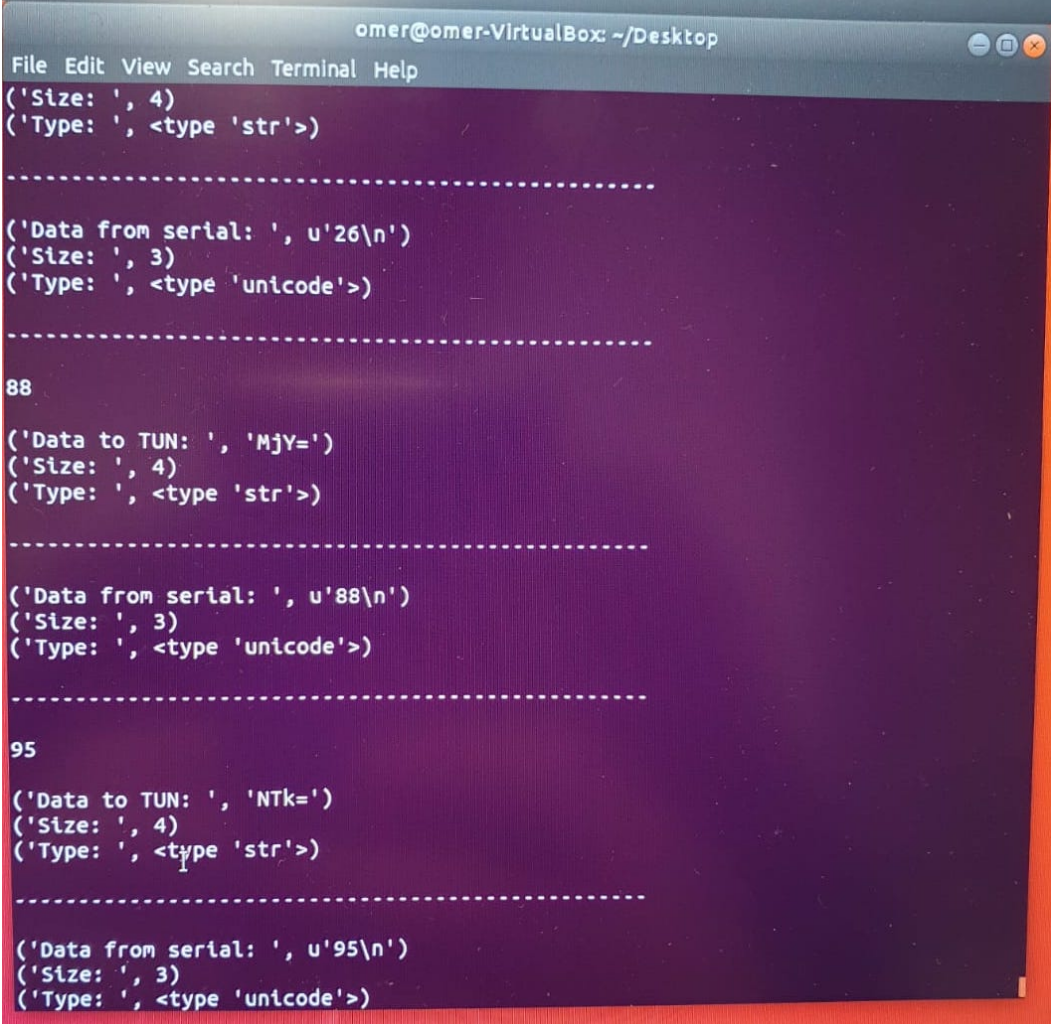

Figure 4.6. Low baud rate: 200bps, receiving signal is same with transmitted signal (yellow line: receiver input, blue line: transmitter output)

4.2. Results

PC1 which has no internet connection sends a ping via the terminal to PC2 which has an active internet connection and transmission occurs using VLC. This ping can be followed on the PC2 terminal and the results can be seen on the terminal.



```

omer@omer-VirtualBox: ~/Desktop
File Edit View Search Terminal Help
('Size: ', 4)
('Type: ', <type 'str'>)
-----
('Data from serial: ', u'26\n')
('Size: ', 3)
('Type: ', <type 'unicode'>)
-----
88
('Data to TUN: ', 'MjY=')
('Size: ', 4)
('Type: ', <type 'str'>)
-----
('Data from serial: ', u'88\n')
('Size: ', 3)
('Type: ', <type 'unicode'>)
-----
95
('Data to TUN: ', 'NTk=')
('Size: ', 4)
('Type: ', <type 'str'>)
-----
('Data from serial: ', u'95\n')
('Size: ', 3)
('Type: ', <type 'unicode'>)

```

Figure 4.7. Serial communication between 2 circuits, "Data from serial" is the received data

The main problem here is creating a network layer between the 2 PCs before starting the experiment. Firstly, the ping address needs to be determined. Generally, there was an error in reading this ping data, so in order to be sure that our circuit works, some other random data was sent over the circuit and read by another PC. After being sure that the circuit works, I focused on getting ping result via Li-Fi.

```

omer@omer-ZenBook-UX433FN-UX433FN: ~/Desktop
()*+,-./01234567')
('Size: ', 84)
('Type: ', <type 'str'>)

-----

('Data to serial: ', '81\n')
('Size: ', 3)
('Type: ', <type 'str'>)

-----

('Data from TUN: ', 'E\x00\x00T\x8cM@\x00@\x01\x8aY\n\x00\x08\x01\n\x00\x08\x02\x08\x00\x05\xe3\n\xbd\x00\xdd\xcc\x00\x00\x00\x00T_\x05\x00\x00\x00\x00\x00\x00\x10\x11\x12\x13\x14\x15\x16\x17\x18\x19\x1a\x1b\x1c\x1d\x1e\x1f !"#%&'()*+,-./01234567')
('Size: ', 84)
('Type: ', <type 'str'>)

-----

('Data to serial: ', '24\n')
('Size: ', 3)
('Type: ', <type 'str'>)

-----

```

Figure 4.8. Serial communication between 2 circuits, "Data to serial" is the transmitted data

```

ubuntu [Çalışıyor] - Oracle VM VirtualBox
dosya Makine Görünüm Giriş Aygıtlar Yardım
Activities Terminal
omer@omer-VirtualBox: ~/Desktop
File Edit View Search Terminal Help

omer@omer-VirtualBox:~/Desktop$ ping 10.0.8.2
PING 10.0.8.2 (10.0.8.2) 56(84) bytes of data:
64 bytes from 10.0.8.2: icmp_seq=1 ttl=64 time=0.016 ms
64 bytes from 10.0.8.2: icmp_seq=2 ttl=64 time=0.047 ms
64 bytes from 10.0.8.2: icmp_seq=3 ttl=64 time=0.039 ms
64 bytes from 10.0.8.2: icmp_seq=4 ttl=64 time=0.042 ms
64 bytes from 10.0.8.2: icmp_seq=5 ttl=64 time=0.028 ms
64 bytes from 10.0.8.2: icmp_seq=6 ttl=64 time=0.036 ms
64 bytes from 10.0.8.2: icmp_seq=7 ttl=64 time=0.126 ms
^C
--- 10.0.8.2 ping statistics ---
7 packets transmitted, 7 received, 0% packet loss, time 6121ms
rtt min/avg/max/mdev = 0.016/0.047/0.126/0.034 ms
omer@omer-VirtualBox:~/Desktop$

```

Figure 4.9. Data From TUN Device

4.3. Limitations with Li-Fi

Some of the limitations were mentioned in the previous sections while explaining the experiment. Here, we list some of the Li-Fi challenges and constraints which must

be taken into account before starting any project or design:

- Li-Fi is only available if the light source exists, because visible light behaves as a data carrier [23].
- Any obstacle between the sender and the receiver disables the communication between them. Any other semi-opaque physical barrier can shorten the range of the signal
- Any other light coming from other sources make a confusion for the system. This is a big problem, because sun is always illuminating the world, so it firstly affect the communication.
- Entirely different infrastructure and mechanism is required in order to implement this mode of communication.
- Since Li-Fi operates on high frequency (400-800 THz), communication results in short distance coverage [23].
- Li-Fi devices can not be places everywhere, because light waves transmit on a directional line.
- Since internet usage is inevitable 24x7, whatever light source is used needs to be switched on even during the day wasting a considerable amount of energy [24].

5. CONCLUSION

Today, VLC is an alternative to radio frequency communication. The system is based on an On-Off keying modulation and demodulation technique. It is cheaper than other communication techniques because this system does not entail special devices and it does not require installing drivers. It just has a transmitter and receiver part in it [25]. It is shown that the computer can connect to the Internet via VLC without any physical cable.

The project is successful, although speed is a problem. When the baud rate or frequency of the light blinking is increased, success rate decreases because LDRs are not in an ideal environment and they can not detect this blinking.

There are some essential future works which will improve the effectiveness and applicability of the communication in discussion. The first one is developing a better software algorithm for detecting the transmitted data in the communication. Secondly, replacing the LDR components in the receiver units with photo diodes will be more costly but more effective than the existing situation.

REFERENCES

1. O'Brien, D., G. Parry and P. Stavrinou, "Optical hotspots speed up wireless communication", *Nature Photon*, Vol. 1, p. 245–247, 2007.
2. Tsonev, D., H. Chun, S. Rajbhandari, J. J. D. McKendry, S. Videv, E. Gu, M. Haji, S. Watson, A. E. Kelly, G. Faulkner, M. D. Dawson, H. Haas and D. O'Brien, "A 3-Gb/s Single-LED OFDM-Based Wireless VLC Link Using a Gallium Nitride μ LED", *IEEE Photonics Technology Letters*, Vol. 26, pp. 637–640, 2014.
3. Kumar, S., K.Sudhakar and L. Rani, "Emerging Technology Li-Fi over Wi-Fi", *International Journal of Inventive Engineering and Sciences (IJIES)*, Vol. 2, pp. 5–6, 2014.
4. Ma, H., L. Lampe and S. Hranilovic, "Integration of indoor visible light and power line communication systems", *IEEE 17th International Symposium on Power Line Communications and Its Applications*, pp. 1–4, 2013.
5. He, Y., L. Ding, Y. Gong and Y. Wang, "Real-time Audio & Video Transmission System Based on Visible Light Communication", *Optics and Photonics Journal*, Vol. 3, pp. 153–157, 2013.
6. Chen, C.-W., W.-C. Wang, J.-T. Wu, H.-Y. Chen, K. Liang, L.-Y. Wei, Y. Hsu, C.-W. Hsu, C.-W. Chow, C.-H. Yeh, Y. Liu, H.-C. Hsieh and Y.-T. Chen, "Visible light communications for the implementation of internet-of-things", *Optical Engineering*, 2016.
7. Khandelwal, K. and S. K. Jain, "A Review Paper on Li-Fi Technology", (*IJIRST/Conference/VIMPACT*), 2016.
8. Haas, H., "LiFi is a paradigm-shifting 5G technology", *Reviews in Physics* 3, pp. 26–31, 2018.

9. Yucebas, D. and H. Yuksel, “Power analysis based side-channel attack on visible light communication”, *Physical Communication*, 2018.
10. Clark, A. P., *Principles of Digital Data Transmission*, John Wiley & Sons, Inc., New York, NY, USA, 1983.
11. Douglase, C., *Internet Working with TCP/IP:Principles, Protocols and Architecture*, Vol. 1, Prentice Hall, 5th edn.
12. Postel, J., *Internet Protocol Darpa Internet Program Protocol Specification, RFC 791*, Information Sciences Institute University of Southern California, 1981.
13. Postel, J., *Transmission Control Protocol Darpa Internet Program Protocol Specification, RFC 793*, Information Sciences Institute University of Southern California, 1981.
14. Yergeau, F., *UTF-8, a transformation format of ISO 10646, RFC 3629*, IETF, 2003.
15. Josefsson, S., *The Base16, Base32, and Base64 Data Encodings, RFC 3548*, IETF, 2003.
16. Alfattani, S., “Review of LiFi Technology and Its Future Applications”, *Journal of Optical Communications*, 2018.
17. Png, L. C. and K. S. Yeo, “Optical Infrastructure for Visible Light Communication for Public Housing and Commercial Buildings”, *The 18th IEEE Symposium on Computers and Communications (ISCC'13)*, pp. 934–939, 2013.
18. Khalid, A. M., G. Cossu, R. Corsini, P. Choudhury and E. Ciaramella, “1-Gb/s transmission over a phosphorescent white LED by using rateadaptive discrete multitone modulation”, *IEEE Photon. J.*, 2012.

19. Grobe, L., A. Paraskevopoulos, J. Hilt, D. Schulz, F. Lassak, F. Hartlieb, C. Kottke, V. Jungnickel and K.-D. Langer, “High-Speed Visible Light Communication Systems”, *IEEE Communications Magazine*, 2013.
20. Grubor, J., S. Randel, K.-D. Langer and J. W. Walewski, “Broadband Information Broadcasting Using LED-Based Interior Lighting”, *Journal of Lightwave Technology*, Vol. 26, pp. 3883–3892, 2008.
21. Muriungi, K. F., “Object Oriented Programming Principles”, *Master’s Thesis, Jomo Kenyatta University*, 2008.
22. Kurt, B., *Object Oriented Programming*, Istanbul Technical University Computer Engineering Department Lecture, 2006.
23. Chakraborty, A., T. Dutta, S. Mondal and D. A. Nath, “Latest advancement in Light Fidelity (Li-Fi) Technology”, *International Journal of Advance Research in Computer Science and Management Studies*, Vol. 5, pp. 47–53, 2017.
24. Sonnad, A. M., A. Gopan, S. N. R and a. A. R. Divya S, “Recent Advancements in LI-FI Technology”, *International Journal of Electrical, Electronics and Data Communication*, Vol. 1, pp. 61–63, 2013.
25. Hamam, H., “Cost-effective communication through visible light”, *4th International Conference on Advanced Technologies for Signal and Image Processing (AT-SIP)*, 2018.