

A DYNAMIC SIMULATOR FOR THE MANAGEMENT OF DISORDERS OF THE
BODY WATER METABOLISM

by

Özge Karanfil

B.S., Industrial Engineering, Boğaziçi University, 2002

Submitted to the Institute for Graduate Studies in
Science and Engineering in partial fulfillment of
the requirements for the degree of
Master of Science

Graduate Program in Industrial Engineering

Boğaziçi University

2005

ACKNOWLEDGEMENT

I would like to express my deepest gratitude to Prof. Yaman Barlas, my thesis supervisor, for his invaluable guidance and support throughout all phases of this research, and for his patience.

I would like to thank Assoc. Prof. Ahmet Ademođlu and Assist. Prof. Aybek Korugan for taking part in my thesis committee and providing valuable comments for my further research.

I wish to express my deepest gratitude to my parents, Gül and Hüseyin Karanfil and to my sister Simge Karanfil, for their never ending support and affection.

I finally wish to thank all of my friends for being with me, especially in my last two years. I am also thankful to the members of Sesdyn Research Group for their great understandings and supports during my study.

ABSTRACT

A DYNAMIC SIMULATOR FOR THE MANAGEMENT OF DISORDERS OF THE BODY WATER METABOLISM

Regulation of the body water and its appropriate distribution between compartments necessitates an understanding of two homeostatic systems: the system that regulates the extracellular (EC) sodium concentration/body water content and the system that regulates the blood volume/sodium content. The main feedback system for body water regulation is the Antidiuretic Hormone (ADH)-thirst system, and the main feedback mechanisms for sodium balance include the Aldosterone and the Atrial Natriuretic Hormones, and the renal mechanisms. In ADH-induced hyponatremia, both the ADH and the thirst feedback loops are dysregulated, and the result is a lower sodium concentration and higher body water content, which may cause serious consequences.

In this study, a simulation model is built using system dynamics methodology to study the body water regulation and its disorders by focusing on the fundamental feedback mechanisms in the normal and disease physiology. This model is then extended to include related therapeutic interventions of a particular body water disorder, namely water intoxication/ hyponatremia, and a game version is produced to test the possible effects of a given set of treatment options on a simulated patient. The model is shown to adequately reproduce the changes in the body fluid balance not only in a normal person as a result of a given disturbance, but also in a hypothetical hyponatremia patient. The interactive simulation game version of the model proves to be a useful experimental platform to describe changes known to occur after administration of various pharmacological means. The aim of the treatment is to increase the EC sodium concentration safely by reducing the body water and replenishing the sodium deficits. Game results demonstrate that hypertonic saline should be given carefully concurrently with drugs that increase urine flow, and ADH-Antagonists happened to be superior over diuretics. The model and the game version constitute an experimental laboratory for a closed-loop therapy approach to hyponatremia.

ÖZET

VÜCUT SIVI METABOLİZMASI BOZUKLUKLARININ TEDAVİSİ İÇİN ETKİLEŞİMLİ BİR BENZETİM MODELİ

Vücudun su miktarı ve bölümler arasındaki dağılımı iki homeostatik sistem vasıtasıyla dengelenir: Hücre dışı sodyum iyon konsantrasyonu/toplam su miktarını kontrol eden sistem ve kan hacmi/sodyum iyon miktarını kontrol eden sistem. Vücut su ve sodyum dengelenmesindeki en önemli geri besleme mekanizmaları ise Antidiüretik hormone (ADH)-susama sistemi ve Aldosteron, Atriyel Natriüretik Hormon, ve diğer böbrek mekanizmalarıdır. Uygunsuz ADH salınımına bağlı olan hiponatremide (su zehirlenmesi), hem ADH hem de susama merkezinin bozulması total vücut sıvılarının artması ve sodyum konsantrasyonunun ciddi sonuçlar doğurabilecek biçimde azalmasına sebep olur.

Bu araştırmanın ana amacı, vücut su metabolizması ve ilgili bozukluklarının normal ve hastalık fizyolojisinde görülen ana geri besleme mekanizmalarına odaklanan bir simülasyon modelinin sistem dinamiği metodolojisi kullanarak kurulmasıdır. Bu model daha sonra ilgili tedavi yöntemlerini de içermek üzere genişletilerek spesifik bir su metabolizması bozukluğu olan su zehirlenmesi (hiponatremi)nin tedavisi için olası tedavi yöntemlerinin sanal bir hasta üzerinde deneneceği etkileşimli bir oyuna dönüştürülmüştür. Modelin hem normal hem de hiponatremik bir kişinin vücut sıvı dengesinin olası değişimlerini uygun şekilde ürettiği gösterilmiştir. Modelin etkileşimli versiyonunun da günümüzde uygulanan tedavi yöntemlerinin bilinen sonuçlarını deneysel bir platformda gösterebildiği görülmüştür. Tedavinin amacı hücre dışı sodyum konsantrasyonunun vücut sıvı hacmi azaltılarak ve sodyum eksiklikleri de yerine konularak ihtiyatlı bir şekilde yükseltilmesidir. Oyun sonuçlarına göre hipertonic solüsyonlar ve idrar miktarını artıran ilaçlar birlikte ve dikkatli bir şekilde verilmelidir. ADH salınımına bağlı olan hiponatreminin tedavisinde, ADH antagonistlerinin diuretic ilaçlardan daha uygun olduğu görülmüştür. Model ve modelin etkileşimli versiyonları hiponatreminin sistem yaklaşımıyla tedavisinde deneysel bir laboratuvar oluşturmaktadır.

TABLE OF CONTENTS

ACKNOWLEDGEMENT	iii
ABSTRACT.....	iv
ÖZET	v
LIST OF FIGURES	ix
LIST OF TABLES.....	xviii
LIST OF ABBREVIATIONS.....	xix
1. INTRODUCTION	1
2. CLINICAL ABNORMALITIES OF BODY FLUID REGULATION	3
2.1. Disturbances of Body Sodium Content	3
2.1.1. Extracellular Fluid Volume Overload.....	3
2.1.2. Extracellular Fluid Volume Depletion.....	4
2.2. Disturbances of Water Metabolism: Dysnatremias	4
2.2.1. Hypernatremia	5
2.2.2. Hyponatremia.....	7
3. DYNAMIC MODELING OF PHYSIOLOGICAL SYSTEMS	20
3.1. Systems Theory in Physiological Models.....	20
3.2. Models for Fluid-Electrolyte Dynamics	21
4. PROBLEM DESCRIPTION AND RESEARCH OBJECTIVE.....	23
5. RESEARCH METHODOLOGY	25
6. OVERVIEW OF THE MODEL	29
6.1. Body Water Sector.....	32
6.2. Sodium Sector.....	32
6.3. Endocrine System Sector Group.....	33
6.4. Urinary Sodium Concentration Sector.....	34
6.5. Treatment Sector Group.....	35
7. DESCRIPTION OF THE MODEL	37
7.1. Description of Body Fluid Control Systems.....	37
7.1.1. Control of Total Body Water and Osmolality	37
7.1.2. Control of Total Body Sodium and Extracellular Fluid Volume.....	40
7.1.3. Integrated Body Water and Sodium Regulation	42

7.2. Body Water Sector	44
7.2.1. Background Information	44
7.2.2. Fundamental Approach and Assumptions	46
7.2.3. Description of the Structure	48
7.2.4. Dynamics of the Body Water Sector in Isolation	55
7.3. Sodium Sector	57
7.3.1. Background Information	57
7.3.2. Fundamental Approach and Assumptions	58
7.3.3. Description of the Structure	60
7.4. Endocrine System Sector Group	64
7.4.1. Background Information	64
7.4.2. Fundamental Approach and Assumptions	68
7.4.3. Description of the Structure	69
7.4.4. Dynamics of the Hormonal System Sectors in Isolation	83
7.5. Urinary Sodium Concentration Sector	86
7.5.1. Background Information	86
7.5.2. Fundamental Approach and Assumptions	88
7.5.3. Description of the Structure	89
8. VALIDATION AND ANALYSIS OF THE MODEL	94
8.1. Basic Dynamics of the Model	94
8.2. Validation of the Model	100
8.2.1. Experiments with Changes in Daily Water Intake	101
8.2.2. Experiments with Changes in Daily Sodium Intake	104
8.2.3. Abnormal Aldosterone Secretion	111
8.2.4. Diabetes Insipidus	114
8.2.5. Water Deprivation	115
8.2.6. Test of the Drinking Behavior	116
9. THE INTERACTIVE DYNAMIC SIMULATOR (BWATERGAME)	118
9.1. Modification of the Model	118
9.1.1. Structures Added to the Original Model	119
9.1.2. Modified Structures of the Original Model	125
9.2. Validation and Analysis of the Modified Model	127
9.3. Game Description	132

9.3.1. Game/Control Panel Screen.....	133
9.3.2. Model Overview Screen	135
9.3.3. Varying the Scenario Screen.....	136
9.3.4. General Information About the Model Screen	136
9.3.5. General Information About the Sliders Screen.....	137
9.3.6. End Game Screens	137
9.4. More About the Game	143
9.5. Results of the Game Tests by Players.....	144
10. CONCLUSIONS AND FURTHER RESEARCH.....	158
APPENDIX A: USER GUIDE OF BWATERGAME	162
APPENDIX B: LIST OF VARIABLES, DEFINITIONS, AND UNITS.....	172
B.1. Body Water Sector	172
B.2. Sodium Sector	174
B.3. Endocrine System Sector Group	175
B.4. Urinary Sodium Concentration Sector	177
B.5. Treatment Sector Group	178
B.6. Game Related-Not in a Sector.....	180
APPENDIX C: EQUATIONS OF THE GAME MODEL	185
APPENDIX D: GLOSSARY.....	201
REFERENCES	204
REFERENCES NOT CITED	213

LIST OF FIGURES

Figure 5.1. Representation of stock and flow variables in model diagrams.....	26
Figure 6.1. Simplified causal loop diagram of the overall model.....	30
Figure 6.2. High-level representation of the sectors of the model and relations between these sectors.....	31
Figure 7.1. Causal-loop diagram for body water/osmolality control by renal factors and the ADH-thirst system	39
Figure 7.2. Simplified causal-loop diagram for sodium and ECFV regulation.....	42
Figure 7.3. Overall regulation of body fluids by integrated control of body water and body sodium regulators.....	43
Figure 7.4. Stock-flow diagram of the Body Water Sector	49
Figure 7.5. Discontinuous drinking structure employed in the model.....	51
Figure 7.6. Effect of EC osmolality on drinking	53
Figure 7.7. Blood volume as a function of ECF volume	54
Figure 7.8. Mean arterial pressure as a function of blood volume	54
Figure 7.9. Glomerular filtration rate as a function of mean arterial pressure	55
Figure 7.10. Total body water and related flows in isolated sector run with a pulse of water infusion	56
Figure 7.11. Gut water and related flows in isolated run with a pulse of water infusion ...	56

Figure 7.12. Body water compartments in isolated run with a pulse of water infusion	56
Figure 7.13. Total body water and related flows in isolated sector run with a step water infusion	57
Figure 7.14. Gut water and related flows in isolated run with a step water infusion	57
Figure 7.15. Stock-flow diagram of the Sodium sector	61
Figure 7.16. Effect of Aldosterone on sodium excretion.....	62
Figure 7.17. Effect of Atrial Natriuretic Hormone on sodium excretion	63
Figure 7.18. Relationship of plasma ADH to percentage increase in EC osmolality (white circles) and percentage decrease in blood volume (black circles) (From Dunn <i>et al.</i> , 1973).	66
Figure 7.19. Stock-flow diagram of the ADH sector.....	71
Figure 7.20. Effect of ADH pool capacity on ADH production.....	71
Figure 7.21. Effect of ADH pool on ADH availability	72
Figure 7.22. Effect of EC osmolality on ADH secretion.....	73
Figure 7.23. Effect of blood volume on ADH secretion.....	74
Figure 7.24. Causal loop diagram of ADH sector	75
Figure 7.25. Stock-flow diagram of the RAAS	77
Figure 7.26. Effect of mean arterial pressure on renin secretion	78
Figure 7.27. Effect of Angiotensin on Aldosterone.....	79

Figure 7.28. Effect of EC sodium concentration on Aldosterone.....	79
Figure 7.29. Stock-flow diagram of the ANH sector.....	80
Figure 7.30. Effect of EC fluid volume on ANH.....	80
Figure 7.31. Effect of EC-IC fluid volume ratio on ANH.....	81
Figure 7.32. Basic causal relationships between “volume hormones” and body water	82
Figure 7.33. ADH in plasma and related flows in isolated sector run with increasing ECNa concentration.....	83
Figure 7.34. ADH Pool level and related flows in isolated sector run with increasing ECNa concentration.....	84
Figure 7.35. ADH Pool and related flows in isolated sector run with an increasing ECNa concentration and an 80% decrease in secretion capacity	85
Figure 7.36. Actual ADH release and its determinants in isolated sector run with an increasing ECNa concentration and an 80% decrease in secretion capacity.	85
Figure 7.37. Renin, ALD and Perceived ALD stocks in isolated sector run with a decrease in MAP.....	85
Figure 7.38. Renin, ALD and Perceived ALD stocks in isolated sector run with an increasing MAP and mildly decrease in ECNa concentration.....	86
Figure 7.39. Stock-flow diagram of the urinary sodium concentration sector	90
Figure 7.40. Effect of ADH concentration on UNa concentration	90
Figure 7.41. Effect of GFR on UNa concentration.....	91
Figure 7.42. Effect of EC sodium concentration on escape from ADH	92

Figure 7.43. Effect of maximum attainable UNa concentration on UNa concentration	93
Figure 8.1. Dynamics of key variables in the base run.....	94
Figure 8.2. Dynamics of hormonal variables in the base run	95
Figure 8.3. Equilibria of the key variables with discontinuous drinking.....	96
Figure 8.4. Equilibria of drinking and urinary excretion with discontinuous drinking	96
Figure 8.5. Equilibria of hormonal dynamics with discontinuous drinking	96
Figure 8.6. Urine flow following ingestion of 1 L of water;(a) data from Baldes and Smirk, (1934), (b) data for eight subjects (mean \pm std. error), (c) data for one subject - from (Uttamsingh, 1985).....	97
Figure 8.7. Base dynamics of urinary excretion following ingestion of 1 L of water	97
Figure 8.8. Base dynamics of body water following ingestion of 1 L of water (TBW in ml).....	98
Figure 8.9. Base dynamics of body sodium following ingestion of 1 L of water.....	98
Figure 8.10. Normal physiologic relationships among EC osmolality, ADH concentration (AVP axis), urine osmolality, and urine volume in man (from Verbalis, 2003)	99
Figure 8.11. Simulated relationships among urine flow and UNa concentration (a) for the base run, (b) after ingestion of 1 L of water	100
Figure 8.12. Dynamics of key variables in case of increased daily water intake - flows and volumes are in ml.....	101
Figure 8.13. Dynamics of key variables in case of increased daily water intake - cont...	101

Figure 8.14. Dynamics of key variables in case of decreased daily water intake - flows and volumes are in ml.....	102
Figure 8.15. Dynamics of key variables in case of decreased daily water intake - cont. .	102
Figure 8.16. Approximate effect of changes in daily fluid intake on blood volume (from Guyton, 2000).....	103
Figure 8.17. Simulated effect of changes in daily fluid intake on blood volume (in liters)	103
Figure 8.18. Model behavior for excessively low water intake.....	104
Figure 8.19. Dynamics of key variables in case of increased sodium intake	105
Figure 8.20. Dynamics of key variables in case of increased sodium intake – cont.	105
Figure 8.21. Dynamics of key variables in case of extreme sodium intake	106
Figure 8.22. Dynamics of key variables in case of extreme sodium intake – cont.....	106
Figure 8.23. Dynamics of body water compartments in case of extreme sodium intake .	106
Figure 8.24. Dynamics of key variables in case of decreased sodium intake.....	107
Figure 8.25. Dynamics of key variables in case of decreased sodium intake – cont.....	107
Figure 8.26. Hormonal dynamics in case of decreased sodium intake.....	108
Figure 8.27. Sensitivity of ECNa concentration to different daily sodium intakes	108
Figure 8.28. Effect of changes in sodium intake on ECNa concentration (1) under normal conditions (2) after the ADH-thirst feedback has been blocked - from Guyton (2000).....	109

Figure 8.29. Simulated effect of changes in sodium intake on ECNa concentration (1) under normal conditions (2) after the ADH-thirst system has been blocked	110
Figure 8.30. Effect of changes in sodium intake on ECNa concentration (1) under normal conditions (2) after the ALD feedback has been blocked-from Guyton (2000).....	110
Figure 8.31. Simulated effect of changes in sodium intake on ECNa concentration (1) under normal conditions (2) after the ALD feedback has been blocked.	111
Figure 8.32. Model response of cessation of Aldosterone secretion	112
Figure 8.33. Aldosterone loading: Open circles indicate experimental data of Relman and Schwartz (1952); solid circles indicate experimental data of Davis and Howell (1953); taken from Cameron (1977).	113
Figure 8.34. Model generated outputs for Aldosterone loading	113
Figure 8.35. Model generated outputs for Aldosterone loading – cont.	114
Figure 8.36. Dynamics of the key variables in Diabetes Insipidus - continuous case	114
Figure 8.37. Drinking and urinary excretion in Diabetes Insipidus - discontinuous case	115
Figure 8.38. The model behavior in case of water deprivation	116
Figure 8.39. The model behavior in case of water deprivation – cont.	116
Figure 8.40. Increase in body water by drinking following a dehydration of 4.5 percent TBW. Circles indicate experimental data.	117
Figure 8.41. Simulation of percent change in TBW by drinking following a dehydration of 4.5 percent TBW	117

Figure 9.1. Stock-flow diagram of the Diuretic sector	146
Figure 9.2. Causal-loop diagram of the Diuretic sector.....	121
Figure 9.3. Effect of Diuretic on sodium excretion	122
Figure 9.4. Effect of Diuretic on UNa concentration	122
Figure 9.5. Effect of Aquaretic on UNa concentration.....	122
Figure 9.6. Effect of Aquaretic on ADH concentration.....	123
Figure 9.7. Stock-flow diagram of the Saline Infusion Sector	123
Figure 9.8. Measurements of the Game	124
Figure 9.9. Hourly and daily ECNa concentration correction rates and messages.....	125
Figure 9.10. Modified effect of EC Osmolality on drinking	126
Figure 9.11. Isolated run of the Diuretic sector with an oral dose of Diuretic	128
Figure 9.12. Isolated run of the Diuretic sector with an intravenous dose of Diuretic.....	128
Figure 9.13. Cumulative volume - time relationship of a series of doses of Aquaretic in comparison to placebo (dotted lines) (Modified from Yamamura <i>et al.</i> , 1993).....	128
Figure 9.14. Model behavior of cumulative volume-time relationship of one dose of Aquaretic in comparison to placebo (1 st line).....	129
Figure 9.15. Dynamics of key indicators when only ADH is dysregulated	130
Figure 9.16. Dynamics of water and sodium flows when only ADH is dysregulated.....	130

Figure 9.17. Dynamics of key indicators when only thirst is dysregulated.....	130
Figure 9.18. Dynamics of water and sodium flows when only thirst is dysregulated	131
Figure 9.19. Appearance of hyponatremia when both ADH and the thirst functions are dysregulated.....	131
Figure 9.20. Dynamics of water and sodium flows when the ADH-thirst mechanism is dysregulated.....	132
Figure 9.21. Game/Control Panel Screen	138
Figure 9.22. Model Overview Screen.....	139
Figure 9.23. Varying the Scenario Screen	140
Figure 9.24. General Information About the Model Screen	141
Figure 9.25. General Information about Input Sliders Screen.....	142
Figure 9.26. Saline infusion decisions of the representative player	145
Figure 9.27. Diuretic decisions of the representative player	145
Figure 9.28. ADH-Antagonist decisions of the representative player	146
Figure 9.29. Dynamics of ECNa concentration for the representative player.....	146
Figure 9.30. UNa concentration dynamics for the representative player	146
Figure 9.31. Dynamics of total body water for the representative player	147
Figure 9.32. Dynamics of IC fluid volume for the representative player.....	147
Figure 9.33. Dynamics of EC fluid volume for the representative player.....	147

Figure 9.34. Dynamics of mean arterial pressure for the representative player	148
Figure 9.35. Dynamics of urine output for the representative player	148
Figure 9.36. Dynamics of hourly ECNa correction rate for the representative player	148
Figure 9.37. Dynamics of daily ECNa correction rate for the representative player.....	149
Figure 9.38. Dynamics of patient's daily water intake for the representative player	149
Figure 9.39. ANH and Renin dynamics for the representative player.....	150
Figure 9.40. ALD and ADH dynamics for the representative player	150
Figure 9.41. Dynamics of the ECNa concentration for five players.....	153
Figure 9.42. Dynamics of the total body water for five players	154
Figure 9.43. Dynamics of the hourly ECNa correction rate for five players.....	154
Figure 9.44. Dynamics of the daily ECNa correction rate for five players	155
Figure 9.45. Dynamics of the mean arterial pressure for five players.....	155
Figure 9.46. Dynamics of the UNa concentration resulting from decisions for five players	156
Figure 9.47. Sodium intakes resulting from decisions of five players	156
Figure 9.48. Dynamics of the sodium excretion rate for five players	157
Figure 9.49. Dynamics of the total water intake for five players	157

LIST OF TABLES

Table 7.1.	Normal values of body water compartments (in liters)	45
Table 8.1.	Simulated levels of ECNa concentration with different daily sodium intakes	109

LIST OF ABBREVIATIONS

ADH	Antidiuretic Hormone
ALD	Aldosterone
ANG	Angiotensin
ANH	Atrial Natriuretic Hormone
AVP	Arginine Vasopressin
BV	Blood volume
CHF	Congestive Heart Failure
DI	Diabetes Insipidus
EC	Extracellular
ECFV	Extracellular fluid volume
ECNa	Extracellular sodium
ECOsm	Extracellular osmolality
GFR	Glomerular Filtration Rate
IC	Intracellular
ICFV	Intracellular fluid volume
ICOsm	Intracellular osmolality
ICU	Intensive Care Unit
K	Potassium
L	Liter
MAP	Mean Arterial Pressure
Na	Sodium
ODS	Osmotic Demyelination Syndrome
PV	Plasma volume
RAAS	Renin-Angiotensin-Aldosterone System
SIADH	Syndrome of Inappropriate Antidiuretic Hormone Secretion
TBW	Total body water
U	Urine (or Urinary)
UNa	Urinary sodium
UOsm	Urine osmolality
V	Volume

adj	adjustment
att	attainable
avail	availability
cap	capacity
chg	change
clear	clearance
conc	concentration
const	constant
del	delay
eff	effect
excr	excretion
max	maximum
mEq	milliequivalents
min	minimum
ml	milliliter
pct	percent
prod	production

1. INTRODUCTION

The homeostatic regulation of body fluids is important in almost every field of medicine and has been thoroughly investigated in this century. The importance of the body fluid system is based on its ability to keep a constant *milieu interior*, a condition of free and independent existence, as emphasized by Claude Bernard (Schrier *et al.*, 1993).

The task of the regulation of body water and its composition is mainly accomplished by two control systems that are interacting in nature: the systems that control the body water and the body sodium content, respectively. Like any other physiological control system, these systems are governed by what is known as negative (compensating) feedback. Body water essentially consists of extracellular (EC) and intracellular (IC) water. The main system for body water regulation is the Antidiuretic Hormone (ADH) - thirst feedback system. The basic function of ADH is to control the sodium concentration and the body water volume. It accomplishes this by reacting to any variation in the extracellular sodium concentration so as to restore it to its normal value. The regulation of sodium balance is more intricate, and the main systems involved are the Aldosterone (ALD) System, the Atrial Natriuretic Hormone (ANH), and the renal mechanisms. The main function of ALD is to maintain a constant EC fluid volume. It achieves this by reacting to changes in Angiotensin hormone levels, which is a function of blood pressure. Similarly, ANH tries to maintain a constant EC fluid volume, and it also reacts to changes in sodium content and tries to keep a constant sodium to potassium ratio. Sodium and potassium are confined to the EC and to the IC fluid compartments, respectively.

Problems associated with body fluid disorders are very common in hospitalized patients. Among these, water intoxication (or hyponatremia) defined as an abnormally low level of plasma sodium concentration, is the most important body fluid disorder with the potential for significant mortality. The treatment of hyponatremia constitutes a problem, partly because all available therapies have significant limitations. For example diuretics, a commonly used drug category for hyponatremia, are associated with many potential

complications such as significant urinary losses of electrolytes. Inappropriate doses of drugs may also cause dehydration.

Furthermore, it is observed that a big portion of hyponatremia incidences are in fact “hospital-acquired”. Most of these patients acquire hyponatremia as they receive intravenous fluids, which is a very common practice in hospitals. Today, more than 75% of currently recommended intravenous fluids are in the form of electrolyte-free water, which is known to aggravate hyponatremia (Halperin and Bohn, 2002). Moreover, many cases are associated with progress from mild to more severe levels of hyponatremia during management of other disorders. This growing trend raised doubts related to hyponatremia, and inspired many studies on its diagnosis and optimum therapy for reevaluation of the current practices (Shafiee *et al.*, 2003).

Due to the feedback complexity of the underlying structure and its interactions with various pharmacological means, body water regulation and its disorders constitute a suitable area for system dynamics simulation modeling. However, no closed-loop therapy approach for disorders of hypo- and hypernatremia has been yet attempted (Northrop, 2000). This study attempts to build a closed-loop system dynamics model for body water disorders, and particularly for ADH induced hyponatremia.

First, in the following section, main disorders of body fluid control systems are discussed. Then, a brief review of systems-theoretic research in body water disorder treatment is provided. In the remaining chapters we present our system dynamics model, together with major validity tests results. Finally we convert the model into an interactive simulation game and discuss the results obtained from some typical gaming experiments.

2. CLINICAL ABNORMALITIES OF BODY FLUID REGULATION

In health, total body water and its distribution throughout the body is maintained between narrow limits. This task is accomplished by two distinct but interactive systems that respectively regulate the extracellular fluid (ECF) volume/sodium content and the total body water (TBW)/osmolality (The normal operation of these homeostatic systems is explained in Section 7.1). Due to their functional interrelationships, any influence which alters the balance of one of these systems inevitably affects the balance of the other. Therefore, it is important to differentiate the clinical abnormalities of ECF volume/Na content from those of the TBW/osmolality regulation.

2.1. Disturbances of Body Sodium Content

As the major cation of the EC fluid, the sodium content determines the ECF volume. Therefore disorders of sodium metabolism are always manifested as disorders of volume status. Moreover, due to the close interrelationship between ECF volume and the mean arterial pressure (MAP), MAP is also dysregulated. Disorders of sodium metabolism commonly coexist with disorders of water and fluid-electrolyte balance; thus a careful clinical examination and laboratory tests help to the correct diagnosis and evaluation.

Disturbances in body sodium content can be broadly categorized into two groups:

2.1.1. Extracellular Fluid Volume Overload

These are abnormal conditions that are associated with expanded ECF volume and generalized edema. Edema refers to a clinically detectable excess of extravascular ECF volume, which may be localized or generalized. In patients with edematous states, the effective arterial blood volume is reduced due to the maldistribution of ECF volume, which in turn results in conserving sodium and water despite elevated body fluid volumes. The

prototypical disorders of this category are congestive heart failure (CHF), hepatic cirrhosis, and nephrotic syndrome (Bagby *et al.*, 1998).

2.1.2. Extracellular Fluid Volume Depletion

These disorders are associated with deficiency and depletion of sodium. Most of the time, absent or diminished sodium intake is combined with excessive sodium loss, due to vomiting, excessive sweat production or any other cause. Since loss of sodium leads to loss of water so long as osmoregulation continues, ECF volume is also depleted. On the other hand, the cell volume is unaffected from the loss of water, unlike in the case of the primary loss of water. Hence, the burden of water loss is solely on the circulation. Another danger is the possibility of a vicious cycle, which may develop due to activation of ADH-thirst mechanism, and may result in retention of water without sodium.

2.2. Disturbances of Water Metabolism: Dysnatremias

Disorders of sodium and water metabolism are frequently encountered in hospitalized patients. They are clinically manifested by disorders of EC sodium concentration/dysnatremias, since the regulatory systems controlling water metabolism do so by maintaining a constant EC sodium concentration. (The body water control mechanism is explained in Section 7.1.1). Loss of water leads to hypernatremia, cell shrinkage and widespread functional disturbances, particularly in the brain. On the other hand, accumulation of water leads to hyponatremia, cell swelling and disturbances in central nervous system. These disturbances are often coupled with other disturbances in ECF volume, other electrolytes, and acid-base balance, and may present with a myriad of symptoms which may mimic other disease states (Haslett *et al.*, 2003)

In general, failure to maintain body water between narrow limits includes two components. The first one is associated with the capability to dilute or concentrate urine appropriately, and the second one is associated with the thirst function. The consequences of a derangement in the urinary concentrating ability or thirst function vary widely, since

under normal conditions the human body has also some adaptive mechanisms for a possible failure in one of these components. Furthermore, if one of these components fails to function properly, the other component may still compensate this failure. However, in most cases, disorders of urinary concentration and dilution are coupled with a concomitant derangement of the thirst function, and this leads to marked changes in volume and composition of body water (Jamison *et al.*, 1982).

As mentioned before, clinical abnormalities of body water content can be categorized according to the level of the EC fluid sodium concentration. Indeed, the EC sodium concentration is the primary measurement of body fluid status. Under normal conditions, the EC sodium concentration is maintained between 135-145 mEq/L, and 105-175 mEq/L are the limits for survival.

2.2.1. Hypernatremia

Increased levels of EC sodium concentration may result either from loss of EC water, or excess of sodium in the ECF. Ordinarily, the ADH-thirst mechanism ensures that a primary loss of water only occurs when water intake is not possible (e.g. when water is in short supply, or when the patient is very young, very old, unconscious or confused so that he/she is unable to communicate). Therefore hypernatremia is mostly seen when there is excess loss of water, e.g. with hyperventilation, high environmental temperature, fever, or abnormal urinary loss (Haslett *et al.*, 2003). The most common causes of hypernatremia are indicated as inadequate hydration or correction (57%) and continuous diuretic treatment (38%) (Halperin *et al.*, 2002). In any case, when replenishment of excreted water is inadequate, severe dehydration may cause weakness, fever, psychic disturbances, hypotension, tachycardia, prostration, and death (Kasper *et al.*, 2004). The clinical situation of the patient becomes more aggravated as serum sodium concentration rises.

2.2.1.1. Diabetes Insipidus: Diabetes Insipidus (DI) is the most common type of pathologic condition that is associated with hypernatremia. Insipidus means “tasteless”, therefore the term “diabetes insipidus” distinguishes excessive urine flow (diabetes) caused by inability

to conserve water, from diabetes mellitus in which urine flow is enhanced due to excessive glucose excretion. In DI, deficiencies of ADH production or action lead to production of large amounts of dilute urine, which may reach up to 20-30 liters a day in severe cases. More common, however, urine volume is moderately increased (2,5 to 6 L/day). Consequently, the person becomes dehydrated and has to drink enough to replace this fluid loss. The major causes of DI are pituitary or hypothalamic surgeries and severe head injuries.

The failure to produce or secrete Antidiuretic Hormone (ADH) is called hypothalamic DI (HDI). Most cases of HDI are mild, since at least 80% of ADH stores of the body should be destroyed before symptoms of polyuria (enhanced urine) and polydipsia (enhanced drinking) may appear. If the thirst center of the patient is intact, the person does not become overly dehydrated, and a mildly hypernatremic steady-state can be reached at the expense of increased water turn-over. In moderate cases patients do not complain if they become accustomed to excessive water turnover. However with severe HDI, profound polyuria becomes a great inconvenience, since sleep and most activities of the person will be continuously disturbed due to the need to void and drink. Water deprivation could reduce the urine volume, but the ensuing thirst will be severe and if water deprivation continues, severe dehydration and hypernatremia will develop. Today, HDI can be successfully treated by using an ADH analogue in appropriate doses. However there is considerable individual variation in the dose required, and higher doses may lead to the other extreme, i.e. water intoxication/ hyponatremia. The second mechanism of DI is a decreased ADH responsiveness of the kidney, termed nephrogenic DI (NDI). NDI may have several reasons and its treatment is more difficult than the HDI.

2.2.1.2. Thirst Deficiency Syndromes: When thirst perception is impaired, ongoing fluid losses may be uncorrected, and hypernatremia may occur even though ADH mechanism is adequate to concentrate urine. In these cases, hypernatremia ensues as a result of chronic inadequate intake of fluid, and in contrast to DI, water turnover is highly reduced. In extreme cases, patients never experience thirst and if left themselves, they do not drink. These disorders are referred to as hypodipsic or adipsic hypernatremia, and they present a major management problem. If underlying cause cannot be treated, the only treatment

option is to give adequate fluid intake. Moreover, EC sodium concentration has to be checked frequently in order to prevent extreme fluctuations in EC sodium concentration that may cause crossings from hypernatremia to hyponatremia, and vice versa. This form of hypernatremia is indeed life threatening, but also extremely uncommon.

2.2.2. Hyponatremia

Water intoxication or hyponatremia is the most common and potentially serious electrolyte abnormality in hospitalized patients (Shafiee *et al.*, 2003). It is defined as an EC sodium concentration of less than 135 mEq/L. Decreased levels of EC sodium concentration may result either from loss of EC sodium, or excess of water in the EC compartment. The net result is always a dilution of body fluids. This affects the central nervous system, and impairs mental processes. Cells expand due to extra water, and so they put stress on the organs, especially on the brain, which has little room to expand.

2.2.2.1. Clinical Importance of Hyponatremia: The importance of ECNa concentration is based on its effect on the intracellular (IC) compartment volume. The distribution of water between the ECF and ICF is determined by the ECNa concentration, since the IC solute is relatively constant and water crosses the cell membranes easily to equalize the IC and the EC osmolalities. For example, if ECNa concentration rises, the ECF volume increases, and the ICF volume decreases by the same amount. Therefore, the ICF volume is inversely proportional to the ECNa concentration and the ECNa concentration is indeed used as an indicator for ICF volume. Thus hyponatremia implies that the ICF volume is expanded. This poses a threat particularly for the brain because brain is confined to a rigid space, the skull and approximately 65% of total brain is IC water. Therefore it cannot gain intracellular particles in an acute setting, and brain edema may develop easily, since an increase in brain water of more than 5-10% is life threatening (Bray *et al.*, 1989).

In contrast to the “acute” hyponatremia (developed in less than 48 hours), “chronic” hyponatremia is much better tolerated by the brain cells. In fact, brain is the only mammalian organ that is able to regulate its volume by adjusting its solute content. In

hypernatremia, the brain cells initially shrink, but gradually increase their solute content over the next few hours and restore their normal volume. On the other hand, in hyponatremia they first swell, but then they lose solute with water, and again restore their volume.

3.2.2.2. *Causes of Hyponatremia:* The most common causes of hyponatremia are the Syndrome of Inappropriate Antidiuretic Hormone Secretion (SIADH) (38%), incorrect hydration (19%), and continuous diuretic treatment (30%) (Halperin and Bohn, 2002). Clinical examination can reveal the underlying cause of hyponatremia, and the essential tests include the ECNa concentration, the urine osmolality, and the urine sodium concentration.

3.2.2.3. *Symptoms of Hyponatremia:* Hyponatremia is associated with a broad spectrum of neurological symptoms related to both to the severity and rapidity of the change in the EC sodium concentration. If these clinical signs are present, hyponatremia is called “symptomatic”; otherwise it is termed as “asymptomatic” hyponatremia. When ECNa concentration falls below 125 to 130 mEq/L, nausea and malaise may be seen as earliest findings. Depending on the degree of water retention, the symptoms may expand to include vomiting, headache, disorientation, lack of coordination, eventually followed by confusion (water intoxication), convulsions, coma and respiratory arrest if the EC sodium concentration falls below 115 to 120 mEq/L.

3.2.2.4. *Frequency:* Hyponatremia is usually observed in patients in hospital settings, and incidences of hyponatremia depend largely on criteria used for diagnosis. It may rise up to 15-22%, when hyponatremia is simply defined as an ECNa concentration of less than 135 mEq/L; but only 3-5% of patients have an ECNa concentration of less than 130 mEq/L. The clinical consequences of hyponatremia are rarely seen when it is greater than 125 mEq/L and are generally seen when it is less than 120 mEq/L (Verbalis, 1998). Hyponatremia affects all races with equal gender distribution; however it is more common in the elderly population.

3.2.2.5. *Basic Types of Hyponatremia*: As with the hypernatremia, hyponatremia can be classified into three basic types depending on the EC volume status of the patient, i.e. normovolemic (euvolemic-clinically normal ECF volume), hypervolemic, and hypovolemic. That means it is possible to see hyponatremia with a decreased total body water as well as with overexpansion of total body water. If hyponatremia results from loss of sodium, it is called hypovolemic hyponatremia and is associated with decreased ECF volume. The underlying reasons may be diuretic usage, vomiting, diarrhea, etc. On the other hand, hypervolemic hyponatremia occurs in sodium retaining, edema forming states such as liver cirrhosis, renal disease and congestive heart failure (CHF), which are mentioned among the disorders of sodium metabolism in Section 2.1. Indeed, both hypovolemic and hypervolemic hyponatremia are secondary complications of a primary disturbance in ECF/sodium metabolism. Therefore they especially tend to occur when the primary ECF/sodium disorder is severe. In contrast, the disorders in the category of euvolemic hyponatremia entail primary disturbances of body water osmolality/water regulation, induced by inappropriate production of ADH or by other disturbances that impair water excretion (Bagby, 1998).

Euvolemic hyponatremia is the most common type of hyponatremia of hospitalized patients, which accounts for about 60% of all types of chronic hyponatremia, and the syndrome of inappropriate antidiuretic hormone secretion (SIADH) is by far the most frequently encountered cause of euvolemic hyponatremia (Hirshberg and Ben-Yahuda, 1997)

2.2.2.6. *Syndrome of Inappropriate Antidiuretic Hormone Secretion (SIADH)*: SIADH was first described in two patients with bronchogenic carcinoma in 1957 (Schwartz *et al.*, 2001), and then it is characterized by Bartter and Schwartz. The cardinal features of the SIADH are as follows: Hyponatremia with low EC osmolality, urine osmolality greater than the EC osmolality, excessive renal sodium excretion, absence of edema and volume depletion, normal adrenal and renal function. This syndrome is caused by persistently elevated levels of ADH when combined with sustained fluid intake.

Excessive secretion of ADH results in water retention and consequent dilution of body fluids by forming decreased volumes of highly concentrated urine. Consequently, the most commonly observed effect is a seriously reduced ECNa concentration. ECNa concentration sometimes falls from its normal value of 142 mEq/L to as low as 110 to 120 mEq/L. At those values, patients may die due to coma and convulsions.

As mentioned before, in most patients with this syndrome ECF volume stays within normal limits, and arterial pressure is not elevated. (Schwartz *et al.*, 2001) This can be explained as follows: The inappropriately retained water distributes evenly between the ECF and ICF. The expansion of ECF activates the ECF volume/Na content control system, and this promotes a transient Na loss (Kaye, 1966). Thus, the ECF volume reaches a new steady-state within a clinically normal range, and most of the excess water is confined to the IC compartment. In fact, a subtle ECF expansion may be present, however assessment of the volume status is difficult when differentiating euvoolemia from mild forms of hyper-and hypovolemia (Bagby, 1998).

SIADH Differentials: Hyponatremia is often related to SIADH; nevertheless it can also be associated with different clinical entities. These can be divided into two groups, according to the impairment in water excretion. Diuretics, renal failure, decreased solute intake and cerebral salt wasting are disorders in which renal water excretion is somehow impaired. On the other hand, primary polydipsia and reset osmostat belong to the second group of hyponatremic disorders with normal water excretion. It is important to differentiate SIADH from these disorders before instituting a treatment strategy (<http://www.emedicine.com/med/topic3541.htm>)

Hormone Levels in SIADH: As mentioned before, a marked and transient natriuresis occurs at the beginning of the SIADH. This seems like an adaptive response of the body to prevent a possible elevation of arterial pressure. There is also a discussion whether this natriuresis aggravates hyponatremia (Vieweg and Godleski, 1988, Song *et al.*, 2004). On the other hand, Cogan *et al.* (1988) reported that hyponatremia is mainly related to water retention, and not to sodium depletion. This Na excretion is attributed to the levels of

“volume” hormones; especially the levels of Aldosterone (ALD) and Atrial Natriuretic Hormone (ANH).

It is also logical to assume that excessive Na losses resulting from this natriuresis may secondarily activate the Na retention mechanisms of the body (Song *et al.*, 2004). Both of these Na excretion and Na retention mechanisms are associated with hormone levels of ALD and ANH.

It is observed that in SIADH, plasma ANH levels are increased while plasma ALD levels are decreased. It is concluded that ANH may be partly responsible for the natriuresis in SIADH, since the urinary sodium excretion rate is found to be significantly correlated with the levels of ANH (Cogan *et al.*, 1988). Some studies indicate that ANH levels return to their normal values after the natriuresis; however some relate ANH levels to the degree of hyponatremia and find a negative correlation between ANH and the ECNa levels. On the other hand, ALD levels are mostly reported to fall, contrasting with the state of sodium depletion (Cogan *et al.*, 1988). However it is also observed that severe hyponatremia is associated with a delayed rise in ALD levels.

The conflicting reports regarding to the level of ALD in SIADH shows that the relation between hyponatremia and ALD secretion is not well recognized. One of the reasons may be the delay between the rise in ALD levels and the onset of hyponatremia. This may result from the fact that the stimuli for ALD secretion actually compete in SIADH (Song *et al.*, 2004). While volume expansion promotes a fall in ALD release, decreasing levels of ECNa concentration dictates a rise in ALD. Therefore it should not be surprising that excessive Na losses in SIADH secondarily activate the Na retention mechanisms of the body, like the delayed increase of ALD hormone.

Adaptive Mechanisms in SIADH: Disturbances of every physiological control system in the body, as well as disturbances in water and electrolyte balance, are rapidly followed by adaptation. The adaptive responses of the body do not restore the body to its normal, but

still prevent further detrimental changes and help to maintain a new-steady-state condition (Cumming and Plant, 2003).

In SIADH, the transient natriuresis helps to maintain the ECF within normal limits; however this adaptation response does not stop the accumulation of excess water in the body. In order to achieve a steady-state condition, both the water and the salt balance should reach equilibrium. There are two possibilities to stop the accumulation of excess water. First one is to restrict the fluid intake on purpose, and the second one is to increase the urine flow until the intake and output of water are equal. As mentioned before, SIADH patients continue to drink for unknown reasons. Therefore the only possibility that may prevent a possible circulatory collapse due to overexpansion of body water would be a mechanism that increases urine flow by reducing the urine concentration. Indeed, that is the case observed in severe SIADH patients and it is called “ADH-escape” phenomenon, or “escape from ADH-induced antidiuresis”, which limits the amount of water retained in the body by reducing the antidiuretic effect of the circulating ADH, and re-establishes the body water balance. The result is a newer and stable, albeit lower, sodium concentration, and higher body water content (Verbalis *et al.*, 1989; Ecelbarger *et al.*, 1998; Song *et al.*, 2004; Ishikawa *et al.*, 2004; Verbalis; 1994, 1998; <http://www.emedicine.com/med/topic3541.htm>).

2.2.2.7. Management of Hyponatremia: The diagnosis and management of salt and water abnormalities in general and hyponatremia in critical patients in particular is also often challenging since inappropriate treatment can aggravate the problem. These challenges are especially important for problems of fluid and electrolyte balance in an Intensive Care Unit (ICU) setting because they may become life threatening very rapidly. The most important aspects that should be paid special attention for clinical evaluation of hyponatremia are the EC fluid volume status of the patient, the symptoms and signs present, the rate at which hyponatremia has developed, and the severity of the hyponatremia. (Cumming and Plant, 2003).

In general, clinical features and symptoms of hyponatremia are rarely seen with an ECNa conc. of more than 125 mEq/L and these patients may not require specific treatment

to raise their ECNa conc. However with more severe degrees of hyponatremia, i.e., at values below 110 mEq/L, hyponatremia may produce significant morbidity and mortality because of coma and convulsions (Verbalis, 1998). Therefore, an ECNa conc. of 110 mEq/L or less is thought to be extremely dangerous in general, and urgent assessment and some form of therapy is required. At levels below 110 mEq/L, mortality rates of 33% to 86% have been cited, though some researchers have smaller estimates (Sterns, 1987).

The rate at which hyponatremia is developed is another differentiating factor for the treatment strategy as mentioned above. In fact the first decision one must take when dealing hyponatremia is to determine whether it represents an acute (documented course is less than 48 hours) or a chronic condition (Halperin and Bohn, 2002). It is crucial to separate acute from chronic hyponatremia before starting treatment, since the dangers for the patient are different (Edoute *et. al.*, 2003). The main risk with acute hyponatremia is brain cell swelling, and hence the treatment of acute hyponatremia should focus on reducing the size of the brain. Even the mild symptoms of an acute hyponatremia may lead to clinical deterioration very rapidly so the treatment must be prompt and vigorous. In contrast, the main risk with chronic hyponatremia is the osmotic demyelination syndrome (ODS, also known as central pontine myelinosis), which may appear secondary to an overly aggressive therapy and produce neurological morbidity and mortality in some cases (Halperin and Bohn, 2002; Song, 2004). Indeed, rapid correction of hyponatremia due to any cause can produce serious irreversible neurological consequences, ODS, and death.

The fact that an overly rapid correction of hyponatremia may cause brain damage caused an ongoing controversy regarding to optimal treatment guidelines of severe hyponatremia. Physicians and researchers have been reviewed the subject extensively with the intention for finding the most appropriate therapy for this important group of patients (Baylis, 2003); but to date, all of the present therapies in patients with ADH-induced hyponatremia have significant limitations (Janicic and Verbalis, 2003) The debate is also extending over the degree and time of onset of hyponatremia, the development of clinical measures and long-term morbidity and mortality.

On the other hand a general consensus has emerged that is directed towards balancing the risks of hyponatremia against the risks of its correction, although both risks vary greatly between individuals. According to this consensus based on clinical and experimental results, the rate of correction of symptomatic hyponatremia should be no more than 0,5 mEq/L per hour, and the initial treatment should be stopped once a mildly hyponatremic range of ECNa conc. has been reached (apprx. 125 to 130 mEq/L) (Verbalis, 1998). According to the most recent literature, acute hyponatremia should be treated promptly with hypertonic saline (3%) in order to prevent seizures and respiratory arrest. On the other hand, for patients with chronic symptomatic hyponatremia, correction must be rapid during the first few hours (to decrease brain edema), but the total correction should not exceed 8-12 mEq/L over 24 hours to avoid the development of ODS (Decaux, 2001). ODS is dangerous since demyelination of pontine and extrapontine neurons lead to quadriplegia, pseudobulbar palsy, seizures, coma, or death. Therefore, frequent measurements of ECNa concentration during the correction phase are essential to avoid overcorrection. Ideally, the patient should be monitored in an ICU setting.

However in all instances, successful treatment depends on a correct diagnosis of the underlying problem, i.e., finding the condition that caused hyponatremia and include it in the clinical analysis and not simply treat an ECNa conc. value, since various pathophysiologic mechanisms can be at the origin of hyponatremia.

Presently, physicians have two main alternatives when treating hyponatremia: a) They can try to limit fluid intake, and/or b) they can reduce ADH or its effect in the kidney.

Water Restriction: When the underlying cause of the SIADH cannot be treated, water restriction is the present mainstay of treatment as the most traditional mode of therapy. To be more explicit, water restriction means to restrict total fluid intake to less than the total output; since in SIADH, nonosmotic secretion of ADH results in overexpansion of body fluids only if water intake exceeds the sum of insensible and urinary output. In fact, in a patient with a normal-functioning thirst center no consequences may be seen; however in another patient who is unable to communicate or whose thirst center is not appropriately

functioning, catastrophic results may appear. Infants and elderly patients constitute the most risky group in terms of the possible consequences, since they are less able to indicate their thirst, or have deficiencies in their thirst response (Hirshberg and Ben-Yehuda, 1997). Therefore it is important to note that excess ADH secretion alone is not sufficient to produce hyponatremia, and both thirst and the ADH system have to be dysregulated to create the hypoosmolality. Indeed it was shown in hyponatremic patients that they cannot suppress their fluid intake, and they even have an elevated daily fluid intake which was found to be in the order of 2.0-2.5 l. (Palm *et al.*, 2001). In other words, hyponatremic patients have a dysregulated thirst function in addition to inappropriate ADH release, which often results from an associated defect in the osmoregulation of thirst.

Though water restriction seems to be the simplest solution to the problem, compliance with it is poor, in part because ADH also stimulates thirst, and because in the long term it can be difficult and unpleasant/distressing for the physician and for the patient. Moreover, severe water restriction could only be imposed while the patient is hospitalized, but once the fluid intake is liberalized or even relaxed, hyponatremia will recur. Therefore successful treatment comprises liberalization or at least relaxation of fluid restriction. Some combination of drug/ fluid therapy is advocated to manage chronic hyponatremia in addition to a mild fluid restriction that could be sustained by the patient.

Today there are two main categories of drugs which may be used for reducing the effect of ADH in the kidney, diuretics and ADH-Antagonists:

Diuretics: Diuretics are occasionally used in the management of edematous (volume loaded) hyponatremic states and chronic SIADH, if urine is highly concentrated (Janicic and Verbalis, 2003; Goh, 2004). The category of loop diuretics is mainly known for reducing the ability to excrete dilute urine (Nyugen and Kurtz, 2003). The net effect of loop diuretics on urinary concentrating ability is to prevent formation of either concentrated or dilute urine (Jamison, 1982).

However diuretics are also associated with some potential complications. They cause significant urinary losses of sodium, potassium, and magnesium and thus may cause an electrolyte imbalance such as hyponatremia and hypokalemia. Indeed, the group of thiazide diuretics is well-known for inducing severe hyponatremia. They were responsible for inducing severe hyponatremia in 94 percent of 129 cases reported between 1962 and 1990; unlike furosemide, the most common loop diuretic. (Sonnenblick, 1993). Diuretics also activate the renin-angiotensin-aldosterone system (Weir and Dzau, 1999). In spite of these counterindications, in SIADH, they still constitute an alternative treatment approach when combined with plentiful sodium intake.

ADH-Antagonists (“Aquaretics” or “water diuretics”): These constitute the most recent and promising pharmacological tool for the therapy of disorders of water metabolism, and specifically for the treatment of patients with water excess and consequent dilutional hyponatremia (Schrier *et al.*, 1993; Janicic and Verbalis, 1993). They have been also termed as “aquaretics” or “water diuretics” because of their ability to increase free water excretion without affecting solute excretion. Orally effective ADH receptor antagonists were reported in 1991 and 1992 (Yamamura *et al.*, 1991 and 1992), and this has aroused a great interest in ADH research and clinical use. Saito *et al.* (1996) were the first to report results of a clinical trial in hyponatremic SIADH. They demonstrated that ADH Antagonists induce prompt and dose-dependent increases in urine volume and parallel decreases in urine osmolality; and consequently a substantial improvement in ECNa concentration is observed. The ongoing ADH research now focuses on the development of a potent ADH-receptor antagonist that can be safely administered orally over the long term.

Possible side-effects of ADH receptor antagonists are also indicated. At high doses, these drugs appear to increase the current ADH concentration in plasma (Wong and Verbalis, 2002). Moreover, high doses may also dispose the patient to dehydration, or even to ODS, if correction is rapid. Therefore, patients with SIADH receiving ADH-Antagonists require close monitoring to prevent a rapid correction. It should also be kept in mind that ADH-Antagonists should only be used in euvoletic (blood volume is normal) or hypervolemic (blood volume is elevated) disorders, e.g., in SIADH, cirrhotic heart failure,

cirrhosis with ascites. It is obvious that ADH-Antagonists are not an appropriate choice of drug for hypovolemic hyponatremia since it will aggravate hypovolemia and may lead to dehydration and hypotension due to an increased free water excretion. However, when taken together, ADH-Antagonists appear to be effective in correcting hyponatremic disorders and promise to become the most popular therapeutic agents in that area.

Fluid Therapy: Fluid therapy (also known as intravenous fluid administration or saline infusion) is a quite ordinary therapeutic means for hospitalized patients and more than 75% of the currently recommended saline is given in the form of electrolyte-free water (0.2 % saline). The five most common reasons to infuse intravenous fluids are (Shafiee *et al.*, 2003): Defending normal blood pressure, returning the ICF to normal, replacing ongoing renal losses, giving maintenance fluids to match insensible losses, and the need for glucose as a fuel for the brain.

However there are still many problems associated with intravenous fluid administration e.g., finding the optimum therapy for a body fluid disturbance is a very important but yet unsolved question. Recently it became clear that traditional recommendations for intravenous therapy have to be reevaluated, partly because it is seen that patients who have received intravenous fluids often develop hyponatremia hospital (Shafiee *et al.*, 2003). This and other problems regarding saline administration led physicians to extensively review the subject from various viewpoints.

The three most commonly used categories of intravenous fluids, which are also included in the model, are hypertonic, isotonic, and hypotonic fluids, which are classified according to their sodium content. Their description and implications for hyponatremia management can be summarized as follows:

a) Isotonic Saline: This solution has an $[Na^+]$ concentration similar to that of the normal plasma, i.e., it is 0.9 % saline (154 mEq/L Na). Isotonic saline solutions have been also termed as “Replacement solutions”, or “Normal Saline”. They are used to replace the EC fluid, because the fact that their $[Na^+]$ is similar to that of the EC fluid effectively

limits their distribution to the EC fluid. The infusate distributes between the interstitial fluid and the plasma in proportion to their volumes, and the IC fluid volume does not change. As a result, isotonic saline should be considered where the patient is volume depleted.

b) Hypotonic Saline: Hypotonic solutions vary between 0.45% and 0.18 % saline (77 and 30 mEq/L Na). They have an osmolality smaller than the normal plasma osmolality. In general, they are considered less dangerous in fluid therapy, but that can be a grave error in some cases.

Today, more than 75% of the currently recommended saline is given in the form of electrolyte-free water (0.2 % saline) in hospital settings, since traditional recommendations require that hypotonic saline be infused to the patient as a maintenance fluid. However it is obvious that electrolyte-free water will accumulate in the body when ADH is acting. Moreover, frequently it is seen that patients arrive hospitals with a low ECNa conc. because they drank electrolyte-free water while ADH is released secondary to their illness. It would be a grave error to give these patients extra electrolyte-free water in the form of a hypotonic solution. As a consequence of these, physicians should not use hypotonic solutions if the ECNa concentration is lower than 138 mEq/L, unless if they want to limit the rise in ECNa concentration due to a rapid diuresis.

It should also be kept in mind that some other factors exist which increases the risk of developing a more severe hyponatremia if hypotonic solutions are administered. These are the age of the patient, and the skeletal muscle mass relative to body weight. Brain cell number decreases with age, and this puts children and young adults at greater risk. The second factor is also important because 50% of body water is in skeletal muscle in normal subjects (Shafiee *et al.*, 2003).

c) Hypertonic Saline: Hypertonic saline 3% has an osmolality (about 900 mEq/L) three times that of plasma. Its sodium content limits its distribution to the EC fluid, very much like an isotonic saline solution. However in addition to that, a hypertonic solution

will also draw water out of cells and thereby decreases the IC fluid volume, unlike the isotonic saline.

Current standard therapy for severe hyponatremia is administration of graded amounts of hypertonic (3%) saline. However there is a general consensus stating that hypertonic saline should be infused very slowly and carefully in chronic hyponatremia of SIADH, and should be reserved for either significantly symptomatic patients or those with symptomatic acute hyponatremia of duration more than 3 days (Saito *et al.*, 1996). Moreover, it is generally recommended that saline infusion should stop when the ECNa concentration reaches 120-125 mEq/L. After this value is attained, other more traditional modes, e.g. fluid restriction, are recommended (Nyugen and Kurtz, 2003).

3. DYNAMIC MODELING OF PHYSIOLOGICAL SYSTEMS

3.1. Systems Theory in Physiological Models

The capability of living beings to maintain their constancy has aroused a great interest for long time. Hippocrates held the idea that disease is cured by natural powers, which will later be reformulated as: “Each disturbing influence induces by itself the calling forth of compensatory activity to neutralize or repair the disturbance” by Pflüger (Cannon, 1932). However the corresponding term of “homeostasis” was first used by Walter Cannon, a professor of physiology, in his book *The Wisdom of the Body* (1932). In this book, Cannon described the working principles of many physiological systems like the control of blood pressure, blood sugar, water intake, and salinity. These systems appeared to be very different in their design and composition, but Cannon saw that they obey the same principles when viewed in terms of homeostasis, and suggested that physiological systems are mainly dominated by negative feedback loops.

Although Cannon made use of the concepts of today’s dynamic systems, he only used qualitative descriptions in his writings. The second pioneer of systems thinking in physiology, namely Arthur Guyton, was the first to introduce the concept of systems analysis to physicians. From 1950’s on to the end of century, he has built mathematical physiology models combining the results of extensive experimentation with the tools of mathematics, physics, engineering and physiology. He built models of circulatory body fluid dynamics mainly to examine the reasons of hypertension; but the most important message of his works was that complex system behaviors can be examined quantitatively, and in terms of grossly lumped system parameters. This approach then led to the emergence of biomedical engineering, a discipline which changed physiology into a much more quantitative science.

In recent years there has been a considerable increase in the application of the methods of mathematical modeling and dynamic systems analysis, both in physiology and clinical decision making. It is also recognized that the required systems approach is

interdisciplinary, and thus it requires collaboration of clinicians, physicians, mathematicians, biologists, and other related life sciences. Application of systems approach to physiology can both provide a greater understanding of the nature and behavior of complex physiological processes, and can also be used as an aid in the diagnosis and treatment of a disease. The increasing trend for universal health care and the subsequent shift in medicine from individual practice to health care systems is another reason that promotes the current trend in physiology. (The financial cost of US health care systems is currently 8% of GNP, and it continues to increase at about 12% per year (Carson *et al.*, 1983).

3.2. Models for Fluid-Electrolyte Dynamics

The system for regulation of body fluid volume (also called the water balance system) is important to understand diseases such as hypertension and dysnatremias. Though it seems a simple one, this system is one of the most complex physiological systems in the body since it involves many other subsystems. Over the last 50 years numerous models have been presented to illustrate the complexity of body fluid regulation with its interrelationships to the renal, respiratory, endocrine, and cardiovascular systems. However another big portion of fluid-electrolyte models only attempt at modeling the parts of kidney function in isolation, and do not consider the interactions of kidney with the rest of the body. These will not be mentioned here.

First models that represent certain aspects of renal control of body fluids belong to DeHaven and Shapiro (1967) and Reeve and Kulhanek (1967). Whereas DeHaven and Shapiro (1967) only focused on the excretion mechanisms of the body, Reeve and Kulhanek (1967) also included a water-drinking mechanism which they believed to be at least equally important as the excretion mechanism in controlling body fluid volumes.

First integrated models of body fluid regulation that also consider the circulatory system include those by Ikeda (1979) and Abbrecht (1980). The model of Ikeda and co-workers is an integrated model of fluid-electrolyte and acid-base representation. However

the most complex analysis of body fluid dynamics belongs to Guyton and co-workers, which is first published in the *Annual Review of Physiology* in 1972. In his analysis, Guyton reviewed all aspects of circulatory dynamics, as well as the dynamics of the free fluids in the tissues, the fluid in the tissue gel, the fluid in the cells, renal excretion of fluid, and endocrine control of body fluid volumes. Moreover, Guyton constructed an overall circulatory model for examining the causes of hypertension, and Guyton and Coleman (1967) proposed both a simple and a complex model for the long term regulation of circulation. This model has inspired many other studies in this field, but it is also criticized due to its gigantic size and some limitations (Sagawa and Kiichi, 1975).

Cameron (1977) developed a simplified version of Guyton et al. (1972), and adopted the approach of Ikeda and co-workers. On the other hand, Uttamsingh (1981) and Badke (1972) used the simple model of Guyton (1967). Uttamsingh (1985) has also extended his model for the clinical application of patients with renal failure who need regular hemodialysis. A large number of other renal models can be found in Flood et al. (1984a). Recently, a long-term cardiovascular system model is developed by Karaaslan (2004) that integrates the previous models developed by Guyton, Uttamsingh and Coleman. This study focuses on the long-term analysis of the effect of renal sympathetic nerve activity on arterial pressure and sodium excretion.

In this study we adopt a system dynamics modeling approach to model the body water-electrolyte dynamics. The modeling methodology is discussed in Section 5.

4. PROBLEM DESCRIPTION AND RESEARCH OBJECTIVE

Disorders of sodium and water metabolism are frequently encountered in hospitalized patients. Among these, hyponatremia is the most common and potentially serious clinical disorder. Although most cases are mild, hyponatremia is clinically important, and its diagnosis and subsequent management constitutes a challenging problem for physicians. Hyponatremia is associated with increased levels of intracellular water caused by osmosis to balance low levels of extracellular Na concentration.

The main risk with acute severe hyponatremia is brain swelling, a disorder which may produce substantial morbidity and mortality in a very short time. Thus it requires a very prompt and vigorous treatment. On the other hand, rapid correction of any type of hyponatremia can lead to severe neurologic deficits and death, irrespective of the mode of therapy. This dictates a careful treatment strategy which should balance the risks of hyponatremia against the risks of its correction.

Treatment of hyponatremia involves drug therapy and/or intravenous fluid administration. However treatment is often complicated. For instance, diuretics, a common medication means, actually aggravate hyponatremia if inappropriately used. Similarly, improper fluid administration is also known to complicate hyponatremia.

To sum up, both the diagnosis and management of body fluid disorders, in particular hyponatremia, are challenging for physicians, in part due to the complex nature of the body fluid system. It is foreseen that mathematical models of physiological systems can make a significant contribution to the clinical diagnosis and to teaching of many aspects of physiology. They can also provide a means for evaluating hypotheses concerning the underlying pathology of a critical clinical disorder. This view has culminated in the growth of simulation models that are employed as a tool for the therapy of clinical disorders, as well as fluid-electrolyte disorders. Especially interactive simulation games are gaining

popularity as an interdisciplinary bridge between physicians, students, and other disciplines that attempt to formalize physiological relations.

As a result, the goal of this study is to develop an interactive simulation model for a particular body fluid disorder, i.e. hyponatremia, based on system dynamics methodology. The first step towards this objective is to develop a well-validated system dynamics model which represents the structure of the body water and sodium balance for an individual normal adult subject with a given set of initial conditions. Then this model will be modified and extended to include the effects of disease processes, related therapeutic interventions, and possible necessary measurements for diagnosis. Finally, a game version of the modified model will be produced which will allow the user to test the possible effects of a given a set of treatment options on a virtual patient.

5. RESEARCH METHODOLOGY

The purpose of this modeling study is to represent dynamics of the body water and sodium balance in normal and diseased states, with particular emphasis on the physiological feedback mechanisms. It is known that the constancy of the body fluid balance is maintained by various physiological control systems which employ negative feedback, and many disease states are simply abnormalities of a particular control system. However, the time delays and the interplay of various factors (physical, hormonal, etc.) which regulate the function of the kidney makes it difficult or impossible to make quantitative predictions without a mathematical model or computer simulation. Considering the non-linear feedback structure of the system under concern, system dynamics approach turns out to be very appropriate for the quantitative analysis of problems concerning body fluid disturbances and therapy.

System dynamics methodology performs satisfactorily in analyzing and modeling complex, large scale, non-linear dynamic systems, and particularly focuses on the inherent feedback structure. The main assumption of system dynamics approach is that any system is a whole and is composed of many sub-systems. Other important assumptions of System Dynamics are direct causal relationships between variables and interdependence of causal factors through feedback loops. The simulation-based experimentation procedure of system dynamics gives insight about the dynamic complexity of the system under concern; helps to identify the possible causes of the inherent problem, and to assess the overall effect of a therapeutic intervention. This is an important advantage of the methodology over other quantitative approaches considering the purpose of this study.

System dynamics methodology focuses on predicting the dynamic patterns that would result from adopting a given set of policies, rather than predicting values of the system variables point by point. This aspect makes system dynamics applicable to the assessment and control of physiological systems, as any analysis of physiological control system depends upon a broad understanding of the whole physiology, and an anticipation of the overall system response to a series of interventions.

In this methodology, two main building blocks are used in modeling the system of concern. Stocks are briefly accumulating variables that identify the state of the system at a particular time. These stocks are changed via instantaneous inflows and outflows, which are referred as flow variables.

System dynamics modeling uses two main building blocks (Sterman, 2000). Stock (or levels) variables represent accumulations in the system of concern, e.g. population, inventory, body water, etc. The value of a stock variable at a particular time is determined by its previous history and the integral of inflows and outflows in the previous time interval. On the other hand, flow (or *rate*) variables represent the changes in stock variables over time, e.g. births, depletion, sales, drinking, etc. So, they are the only means to manipulate the stocks to which they are connected. Models built with system dynamics methodology correspond to a set of differential or difference equations, in which stocks represent state variables and flows represent rates of change.

Stock variables are usually represented by rectangular boxes in model diagrams and rates are represented as valves on arrows that flow in or out of level variables. Arrowheads indicate the direction of flows. An example stock-flow representation of the simple Population structure is given in Figure 5.1. Differential equations regarding this structure are also given in Equations (5.1), (5.2) and (5.3).

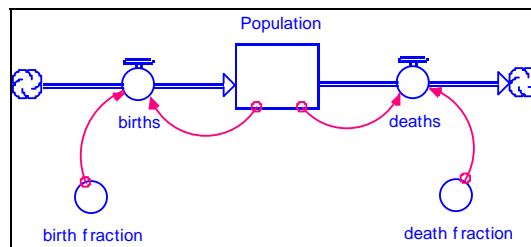

Figure 5.1. Representation of stock and flow variables in model diagrams

$$Population(t) = Population(t - dt) + (births - deaths) * dt \quad (5.1)$$

$$births = Population * birth_fraction \quad (5.2)$$

$$deaths = Population * death_fraction \quad (5.3)$$

The level of this system is *Population*. Population is increased from its current value by the *births* flow and is decreased by the *deaths* flow. Remaining variables *birth fraction* and *death fraction* are called *converter* (or *auxiliary*) variables and they represent how a certain variable depends on another variable at a particular time. Finally, the connecting arrows indicate a causal relationship between two variables in the system.

System dynamics methodology is composed of an iterative modeling process of five stages and a subsequent experimentation (Sterman, 2000). The first stage is problem articulation, which comprises the identification of the dynamic problem that needs to be understood and solved. In this step, the system boundary and the time horizon of the study are determined with selected key variables.

In the second stage of the methodology, a dynamic hypothesis is developed regarding the dynamic problem of the system. This requires revealing the causal structure of the system that involves the feedback relationships between system variables with respect to the past behavior of the system.

The third stage consists of building the mathematical simulation model based on the first two steps. Building of the stock-flow structure of the model is then followed by estimation of parameters, equations and initial conditions based on the observed past data and system behavior.

The fourth stage of the methodology is testing the validity of the simulation model with respect to the problem of concern. This process is actually performed during the development of the model, and includes both the validation of the model structure and its behavior. First, the validity of the model structure is tested against the real system relations. Only if the model passes this test, behavioral validation is performed by comparing the output of the model with observed real dynamic behavior. In validity

testing, it is important that the model is reasonable under extreme conditions and the model behavior is robust to uncertainties in initial conditions and parameters (Barlas, 1996).

The final stage of the methodology is to conduct experiments with the validated model for the purpose of policy analysis and design. This experimentation stage includes the study of the system behavior under various policies, scenarios and conditions. The results are expected to provide insightful information for policy evaluation and design.

6. OVERVIEW OF THE MODEL

The purpose of this modeling study is to develop a dynamic representation of our body fluid balance in normal and diseased states. For this purpose, the study is divided into three parts. In the first part, the normal physiology of the body water balance and its stability will be clarified, and in the second part, the dynamics of a specific body water disorder, i.e. water intoxication/hyponatremia, will be investigated. Lastly, the modified model of the second part will be used in an interactive simulation game for exploring the possible effects of therapeutic interventions, and finding a successful therapy.

In health, total body water and body sodium content are tightly controlled by maintaining a balance between intake of water and electrolytes from the gastrointestinal tract and output of these as urine. In addition to that, not only the volume of the total body water, but also its distribution between compartments, e.g. the blood volume is monitored and maintained within close limits. This stable behavior can be observed in other physiological control systems as well, and is termed as the “homeostasis” principle.

The mechanism for the regulation of water balance is often referred to as the ‘thirst-ADH mechanism’. This system regulates water intake by controlling the perception of thirst, and water output by ADH, which is responsible for urinary concentration and dilution. The two most important factors that are monitored by this mechanism are EC osmolality and intravascular volume (blood volume). The set point of both factors is determined by hypothalamus, and therefore they are assumed to be exogenous to our problem.

Figure 6.1 provides a brief causal-loop diagram of the overall model. The 1st and the 2nd loops demonstrate the ADH-thirst feedback mechanism for EC osmolality and total body water control. Increasing EC osmolality increases the level of ADH, and as a consequence of increased urinary concentration, water excreted in urine decreases. At the same time, thirst perception is stimulated and water intake is increased.

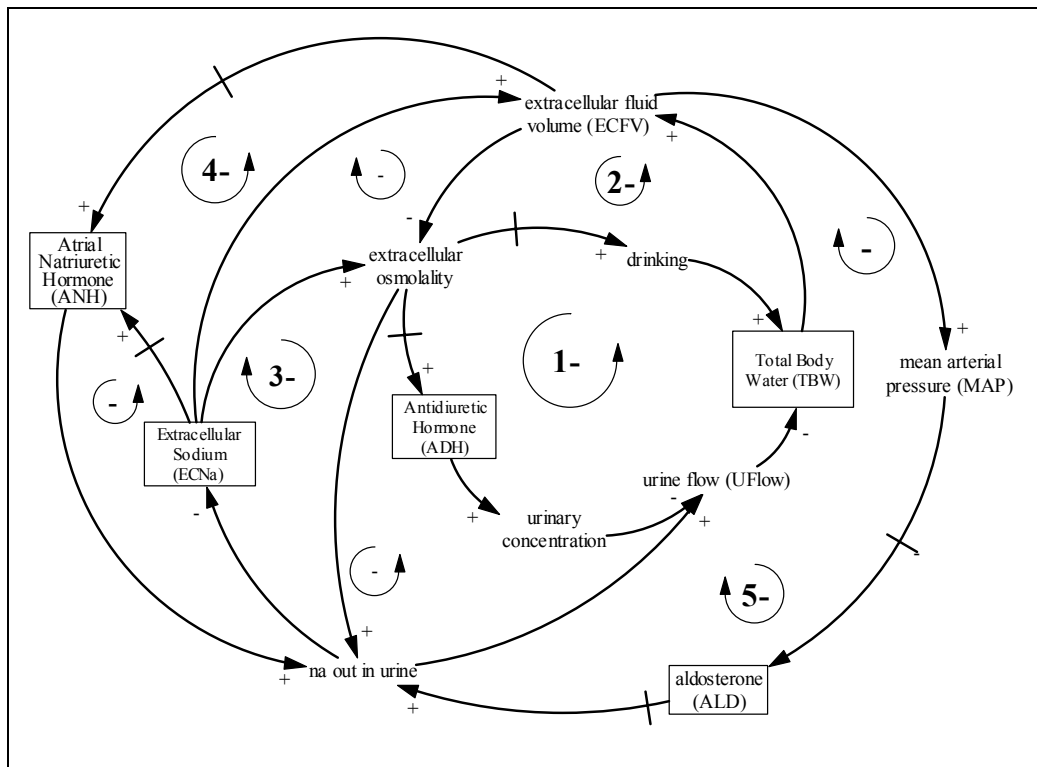

Figure 6.1. Simplified causal loop diagram of the overall model

Regulation of the total body water and its appropriate distribution between compartments necessitates an understanding of two homeostatic systems, i.e. the systems that regulate the total body water and the systems that regulate the blood volume/sodium content, which have a separate but an interactive nature (Bagby et al., 1998). The 3rd, 4th and the 5th feedback loops in Figure 6.1 display the main feedback systems for the blood volume/sodium content regulation. The two major hormones involved are called ALD and ANH.

Both of the above mentioned systems are largely regulated by the homeostatic activity of the kidney, and any hormonal or other influence which alters the balance of one of them inevitably affects the balance of the other. For example, all hormones regulating water and salt balance exert influences on the circulating blood volume and thus on systemic blood pressure to some degree. Therefore, precise regulation of both water and salt balances is only possible if both of these control systems work in an appropriate way.

Section 7.1 will discuss the components of the body water and body sodium control systems in more detail.

The model is composed of nine sectors grouped under five sector groups. These sector groups correspond to body water, sodium, hormonal system, urinary sodium concentration, and treatment. The hormone sector group consists of three hormonal systems, i.e., the ADH, the renin-angiotensin-aldosterone system (RAAS) and the ANH. The treatment sector group also consists of three sectors, i.e., diuretics, aquaretics (or ADH-Antagonists), and intravenous fluid infusion, which correspond to different treatment strategies of hyponatremia. The other sectors, i.e., the body water, sodium, and urinary sodium concentration are represented as single sectors.

As mentioned above, there are other structures in the model in addition to these five sector groups, which do not belong to any of these sectors but are used for the game, messages, extra measurements, time tracing converters, etc.

A high-level representation of all sectors and their interactions are given in Figure 6.2.

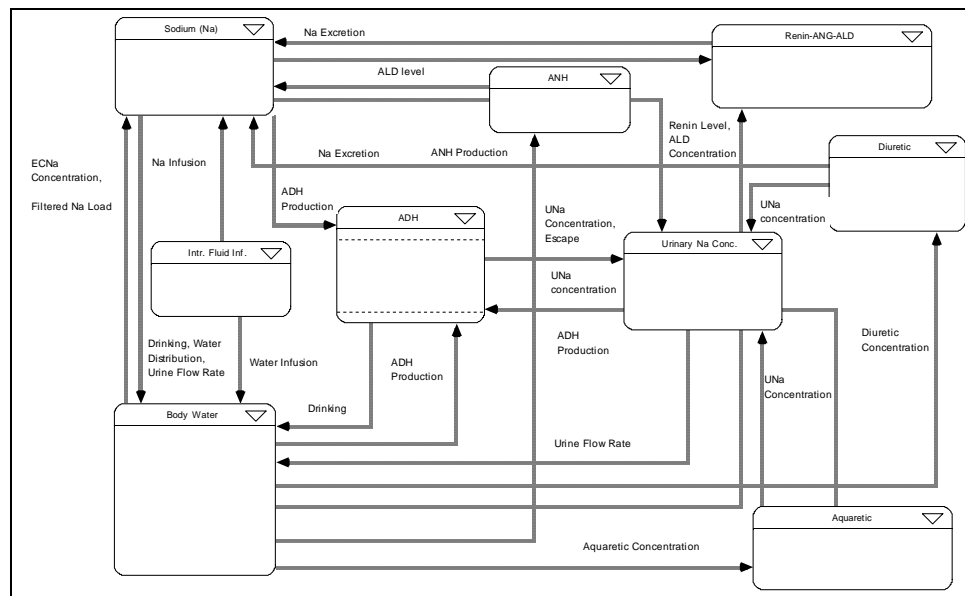

Figure 6.2. High-level representation of the sectors of the model and relations between these sectors

In the following sections, general overviews of the sector groups and the main interactions with other sectors are presented. Underlying assumptions, the approach used, and the structural details of sectors will be discussed throughout Chapter 7.

6.1. Body Water Sector

This sector is constructed to simulate the dynamics of total body water and its distribution between body compartments. The major division of body water is into ECF and ICF based on which side of the cell membrane the fluid lies.

The body water sector considers drinking as the only source of fluid intake. Both continuous and discontinuous drinking options are modeled to simulate the drinking behavior. Discontinuous drinking of the model represents a switch-on and switch off structure, which only acts under some threshold body water level.

A fairly constant water loss, which represents the continuous escape in the form of evaporation, and a varying urinary loss represent the two sources of loss of water from the body. The urine flow rate and the drinking rate are the most important flows of the body water sector which are determined by the feedbacks from other sectors, mainly the ADH, urinary sodium (UNa) concentration, and the sodium (Na) sectors.

Details of this sector are discussed in Section 7.2.

6.2. Sodium Sector

The Na sector simulates the dynamics of Na^+ of the EC fluid, since total body Na^+ is restricted mostly to the ECF. Hence day to day variations in the amount of body Na^+ represent variations in ECF volume (Bray et al., 1989). Indeed, our body regulates the ECFV by regulating its Na^+ content. However, the mechanisms involved in the Na^+ and

thereby ECFV remain controversial unlike the regulation of total body water content through the thirst-ADH mechanism, which is comparatively well understood.

There are many factors which affect the Na⁺ intake and excretion. To date, the factors affecting the Na⁺ intake, i.e., the sodium appetite, are not well known as the factors affecting its excretion. According to the most recent literature, the most important of these that are also included in the model are the glomerular filtration rate, (which affects the filtered load of Na⁺), the RAAS, and the recently found ANH. Activation of the sympathetic nervous system also has an important effect on sodium dynamics; however it is not included in the model.

Details of this sector are discussed in Section 7.2.

6.3. Endocrine System Sector Group

This group of sectors is composed of three subsectors, which are the ADH, RAAS, and ANH. The structure constructed in these sectors is mainly responsible for simulating the dynamics of the major hormones that are responsible for differential excretion of body water and sodium ions.

The ADH sector is constructed to simulate the ADH hormone dynamics and its influence on the urine flow rate. This sector is mainly influenced by the feedbacks from the sodium and body water sectors and its output affects the UNa concentration sector. The RAAS is known as a major controller over sodium and potassium balance and arterial blood pressure. These functions are continuously regulated by changes in angiotensin (ANG) and ALD levels in response to variations in dietary intake of sodium and potassium (Laragh, 1985). Consequently, The RAAS sector is mainly influenced by the body water and Na sectors and it gives feedback to the sodium sector. The ANH subsector is constructed to simulate the dynamics of another important hormone that causes increased excretion of sodium and water. This hormone represents the effect of body fluid expansion on increased

urinary output which could not be fully explained only by changes in glomerular filtration rate (GFR) and ALD levels (Ikeda et al., 1979).

Details of these subsectors are discussed in Section 7.

6.4. Urinary Sodium Concentration Sector

This sector is constructed to simulate the dynamics of the UNa concentration in normal and diseased states. The ability of the kidney to concentrate urine is essential for the survival of mammals that live on land, including humans (Guyton, 2000). Since water is lost continuously from the body, forming a small volume of concentrated urine minimizes the intake of fluid required to match this continuous loss. The kidney can both use its antidiuretic mechanisms to concentrate urine when levels of the body water are low, or its diuretic mechanisms to dilute it by forming watery urine when there is excess water. In other words, the relative constancy of the internal environment can be attained at the expense of a highly variable urine production.

Under normal physiological conditions, the ADH level is the main determinant of urine osmolality. However, there are other factors that can regulate urine osmolality and dilution in the absence or excess of ADH, as in some disease states, i.e hyponatremia, also known as water intoxication. The model includes the most important mechanisms that affect the urine osmolality, i.e., the GFR and the rate of urinary solute excretion. In addition to that, the effects of some drugs on urinary concentrating/diluting capacity of the kidney are also presented in the modified Game version of the model.

Details of this sector are discussed in Section 7.5.

6.5. Treatment Sector Group

The treatment sector is composed of three sub-sectors, from which two of them are almost identical, i.e., Diuretic and Aquaretic (or ADH-Antagonist) sectors. These sectors represent the most commonly used drugs for treatment of hyponatremia, and each one of them is responsible for simulating the dynamics and related effects of its own drug category. These identical drug structures differ only in some graphical functions and initial values of certain parameters.

The third subsector, i.e., intravenous fluid infusion constitutes another important part of the current standard therapy for treating severe hyponatremia. Since various types of intravenous fluids exist; the three most commonly used categories are presented in the model, namely hypertonic, isotonic, and hypotonic fluids, which are classified according to their sodium content.

The Aquaretic and diuretic subsectors mainly interact with the Urinary Na concentration sector, as the main effect of these drugs is to change the urinary concentration. Diuretics increase the sodium excretion rate as well. (i.e., the number of Na ions excreted in the urine per hour). As a consequence, both of these drugs affect the amount of urine flow and its composition.

On the other hand, the Intravenous Fluid Infusion Sector adds to the sodium and water input given to the patient and therefore interacts mainly with the Body Water and Sodium (Na) sectors.

As explained in Section 2.2.2, in patients with the Syndrome of Inappropriate Secretion of ADH (SIADH) and other forms of excess ADH secretion, none of the present treatment options is optimal (Janicic and Verbalis, 2003). Every treatment modality has its own (potential) therapeutic indications as well as its own potential complications (or contraindications). These challenges are especially important for a patient in an ICU setting

because if inappropriately managed, they can add to the already challenging problem and may produce significant morbidity and mortality. (Verbalis, 1998).

Details of this sector group will be discussed in Section 9.1.

7. DESCRIPTION OF THE MODEL

As will be mentioned in Section 7.1, the two major systems that are involved in the homeostatic regulation of body fluids are the system that regulates the osmolality/body water and the system that regulates the blood volume/sodium content. Like any other physiological control system, they have their own sensors, effectors, and a central controller. In this study, the central controller is the hypothalamus, and thus the normal values of all the regulated variables are taken as exogenous constants, e.g. the set point for ADH, the set point for blood volume, the set point for EC osmolality. The effector organ of the body fluid system is the kidney, and thus the regulators of sodium and water balance are united through the kidneys excretion mechanisms. However it is more appropriate to examine these systems separately in order to gain a better understanding of each.

7.1. Description of Body Fluid Control Systems

7.1.1. Control of Total Body Water and Osmolality

Under normal circumstances, both the TBW and its distribution between compartments are maintained between narrow limits. The central controller of water balance is the hypothalamus, but there is no “center” in hypothalamus which is defined to be merely responsible for producing an integrated response to changes in water balance. Hypothalamus controls the TBW via a negative feedback homeostatic mechanism which is often referred to as “thirst-ADH mechanism”. As is understood from its name, its major effector systems are the thirst, and the ADH systems. The sensors of the ADH-thirst mechanism monitor the osmolality of the EC fluid and the effective blood volume by its osmoreceptors, and volume receptors, respectively. In close coordination, these receptors adjust water balance by ADH-mediated changes in free water excretion into urine and thirst-mediated changes in water intake.

If both limbs of the ADH-thirst system are working correctly, then under normal unstressed conditions this system maintains a constant EC osmolality. Under usual conditions, control of EC osmolality means almost the same thing as controlling the ECNa concentration.

So, one might ask the advantage of maintaining a constant EC osmolality in terms of the water balance. A constant osmolality is important in many terms, some of which will be explained in Sections 7.1 and 7.3, but its importance in terms of water balance is that control of EC osmolality controls IC volume. Three facts about the body water and body sodium verify this argument: First, sodium is mostly restricted to the EC fluid; second, intracellular solute does not change easily, third, EC osmolality must equal IC osmolality. From these three facts, it follows that a system whose primary function under usual circumstances is to maintain a constant EC osmolality, i.e. a constant ECNa concentration, actually maintains a constant IC fluid volume since ECNa concentration controls the distribution of water between EC and IC fluids. The constancy of the IC fluid volume, i.e. a constant cell volume is important for maintaining optimum function of most cells, and particularly important for the brain.

Figure 6.1 in Section 6 provides a brief causal-loop diagram that demonstrates the ADH-thirst mechanism for EC osmolality control. However, there are other mechanisms which act independent of ADH, and in some conditions they can have major effects on water excretion. Causal-loop diagram in Figure 7.1 gives a more detailed presentation of osmolality control system by including the most important renal factors that can influence the urine flow rate/urinary concentration, i.e. the GFR and the sodium excretion rate. More information about the urinary concentration/dilution mechanism can be found in Section 7.5.

If total body water increases, this eventually causes an increase in the GFR via increased blood volume, and as a consequence of urinary dilution, urine flow increases. On the contrary, a decrease in GFR results in a fall in urine flow as a result of urinary concentration (3rd loop in Figure 7.1).

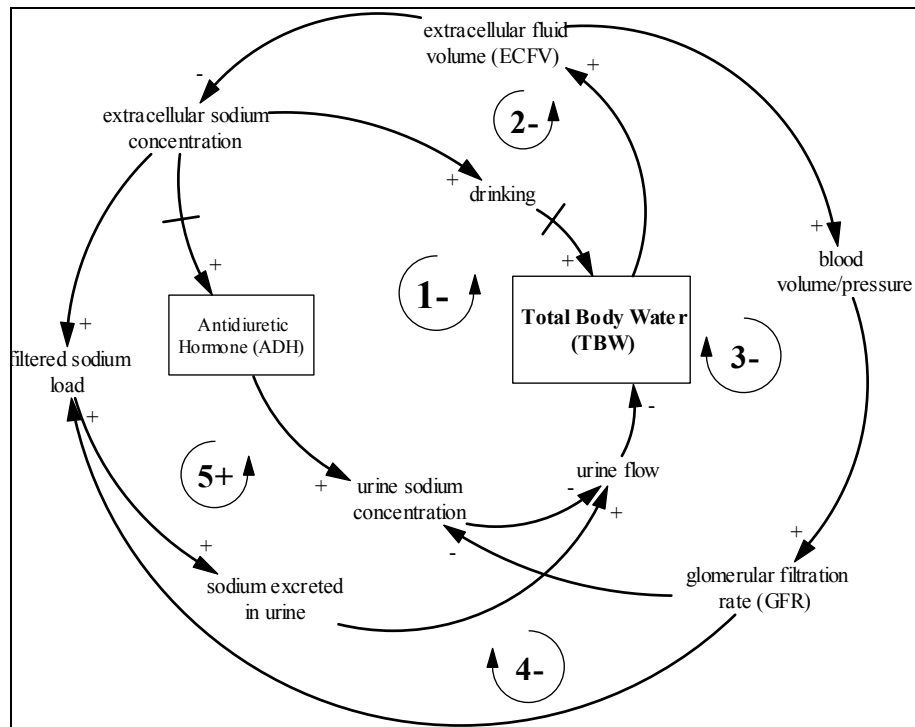

Figure 7.1. Causal-loop diagram for body water/osmolality control by renal factors and the ADH-thirst system

The rate of solute excretion is another determinant that has a direct effect on urine flow, since water excretion depends on solute excretion, as much as urine concentration. As seen in the diagram, GFR and the EC sodium concentration influence the sodium excretion rate by changing the filtered sodium load (4th and 5th loops in Figure 7.1). If filtered sodium load increases, sodium excretion rate increases, too. However increasing body water levels have opposite effects on GFR and EC sodium concentration, and filtered load may increase or decrease, depending on the sodium level in the EC fluid.

However, under usual conditions the GFR is relatively constant, and urine flow is mainly changed by a variable urine concentration determined by ADH. Even so, the importance of these balancing loops may be revealed when the organism is deprived of water. A 10% decrease in arterial pressure can decrease the sodium excretion rate by 10 fold, and thus the amount of water lost by urine is decreased accordingly. Moreover, loss of water will eventually decrease GFR, and this further reduces urine flow to almost undetectable levels due to the concentration of urine, even if ADH is not acting.

7.1.2. Control of Total Body Sodium and Extracellular Fluid Volume

Unlike the regulation of total body water via thirst-ADH mechanism, which is comparatively well understood, the mechanisms involved in the regulation of Na^+ and thereby EC fluid volume (ECFV) remain controversial. This is mainly due to the diverse, complex and interconnected nature of the factors that affect the Na^+ balance.

Maintenance of normal ECFV and ECNa necessitates a balance between Na^+ intake and Na^+ excretion. Under normal conditions, about 15% of body Na^+ is turned over between the gut and the plasma every day. So the amount which can be possibly lost to the environment is very large when compared to the sodium stocks of the body. Therefore, under normal conditions, more than 99% of sodium is reabsorbed back to the plasma (Bray et al., 1989). If Na^+ regulating mechanisms do not work appropriately, rapid loss of Na^+ may lead to a rapid depletion of ECFV, hypotension, coma and death.

In modern industrialized cultures, Na^+ intake is almost always greater than necessary for homeostasis. In fact, the average sodium intake of modern civilizations usually ranges between 100 and 200 mEq/day, even though humans can survive and function normally on 10 to 20 mEq/day (Guyton, 2000). The higher incidence of cardiovascular disorders such as hypertension in modern civilizations is partly attributed to our usual high Na^+ intake, and most of the time it is not possible to control sodium balance by regulating intake (Navar, 1997). Therefore, the kidneys are left with the responsibility of adjusting the sodium excretion rate against large variations in intake. However, it is also indicated that there is a regulatory component to salt appetite, which works under extremely salt deficient conditions such as in Addison's disease, where the sodium retaining hormone ALD is deficient in the body.

According to the most recent knowledge, sodium excretion mainly involves three factors: the filtered load, ALD, and a group of 'third factors'. Together with various other factors, this system is capable to adjust the sodium excretion rate from a few mEq up to about 500 mEq per day, which is a highly variable amount. Filtered load refers to the rate at

which substances are filtered in the kidney. It is found by the equation: Glomerular filtration rate \times plasma concentration of the substance, if it can be assumed that the substance is freely filtered and not bound to any plasma proteins (Guyton, 2000). The other two determinants of renal sodium loss, i.e. ALD, and “third factor” are hormones that retain or excrete sodium by affecting the rate of its filtration and absorption. They also influence other substances, e.g. glucose, water, and K^+ . The effects of the hormonal system on the sodium balance will be outlined in Section 7.3.

As indicated above, three factors are identified to affect the renal sodium excretion. Figure 7.2 provides a brief causal-loop diagram that demonstrates the causal mechanisms related to these three factors. The 1st and the 3rd loops are related to balancing effects of the filtered load. Any change that causes an increase in the filtered load of sodium causes a rise in sodium excretion. It is seen that an increase in ECNa increases the filtered sodium load both through an increased ECNa concentration, and an increased GFR. On the other hand, the 2nd loop indicates that an increase in ECNa also has a decreasing effect on ECNa concentration due to the fluid shift between the IC and the EC compartments. However, it is apparent that the net effect of increased ECNa is a rise in ECNa concentration (ECNa_conc), and thus the 2nd loops effect is always negated by the 1st loop, other things being constant.

The 4th and 5th balancing feedback loops relate to the effects of ALD hormone. If the ECNa level increases, this results in a fall in RA hormone levels, and a rise in ECNa concentration. Sensing of this after a delay decreases the set level of the ALD hormone, and consequently the sodium retaining effects of ALD decrease.

On the other hand, increasing levels of ECNa also trigger the natriuretic mechanisms. Increasing EC fluid volume and the increased ratio of ECNa cause the set level of the ANH to increase, which in turn results in an increased sodium excretion rate. As in the former loops, the loops related to ANH (6th and 7th loops) also act in order to balance the change in ECNa, and thus the ECFV and the blood volume levels.

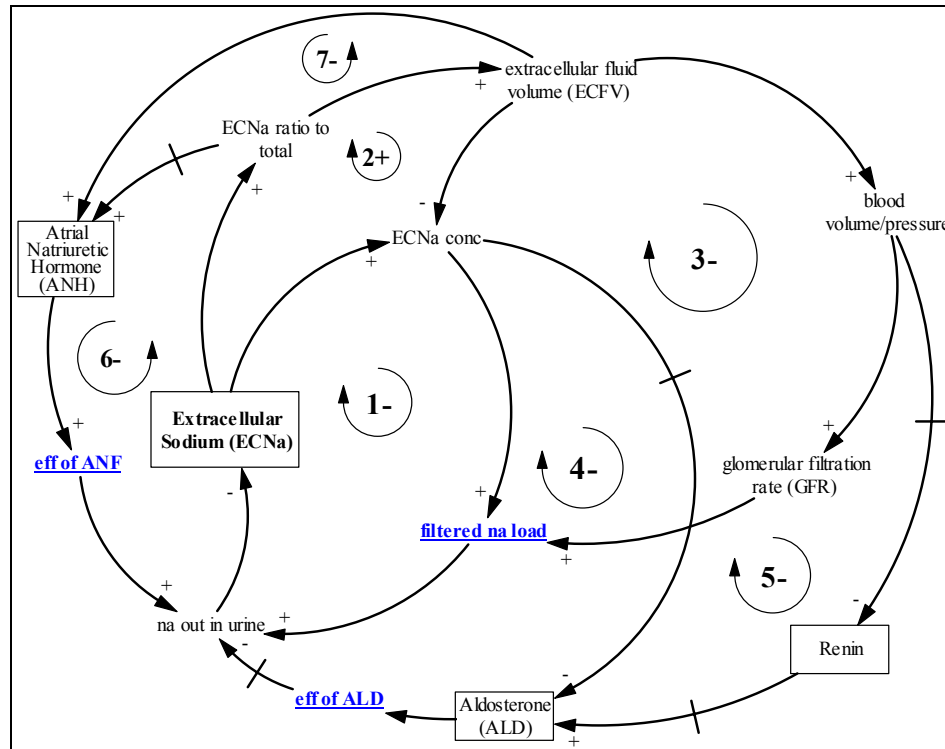

Figure 7.2. Simplified causal-loop diagram for sodium and ECFV regulation

7.1.3. Integrated Body Water and Sodium Regulation

The regulators of body water and body sodium are interactive in nature, and thus the overall system will give an integrated response to any disorder of the body fluid system. Figure 7.3 gives an overall appreciation of how the two control systems of body water and body sodium integrate to produce a tight control system. This diagram may also help to differentiate the clinical abnormalities of EC fluid volume/Na content regulation from abnormalities of body water/osmolality.

As mentioned in Section 2.2.2, SIADH is a disorder of body water homeostasis. In SIADH, high levels of ADH with sustained water intake results in water retention and the development of water intoxication/hyponatremia. However, the degree of water retention is limited due to the adaptive mechanisms of the body, i.e. the kidney adapts via a transient natriuresis and a persistent diuresis. In fact, the pathophysiology of this disease can be better understood when the causal-loop diagram presented below is examined carefully.

In this chapter, each sector is explained in detail. For each sector, background information and fundamental assumptions are given, main variables are defined and the functions representing the relationships between variables are delineated.

In order to distinguish between the variables belonging to each sector, a prefix is used while naming the variables. According to this convention Na stands for Sodium, EC stands for Extracellular, IC stands for Intracellular, B stands for Blood, V stands for Volume, U stands for Urine and Osm stands for Osmolality. For example ECNa_conc and UNa_conc represent the Extracellular Sodium concentration and Urine Sodium Concentration, respectively. Moreover, established abbreviations from the literature are used for some variables. These are: ADH (Antidiuretic Hormone), ALD (Aldosterone Hormone), ANG (Angiotensin Hormone), ANH (Atrial Natriuretic Hormone), GFR (Glomerular Filtration Rate), and MAP (Mean Arterial Pressure).

7.2. Body Water Sector

7.2.1. Background Information

The absolute necessity of water in our physiological processes is beyond dispute, since water is the medium in which all the chemical changes of the body occur. It is the main constituent of digestive secretions, serves as a vehicle of absorption, is involved in the composition of blood and lymph, is used as a lubricant in the body, plays an important role in body temperature regulation, and so on...

However water is continuously escaping from the body, mostly through evaporation, which creates a consequent need for repeated replenishment of body stores. Because of its importance for life, the water conservation and replenishment mechanisms of the body deserve a thorough investigation.

7.2.1.1. Body Water Compartments: Water balance of the body should be considered both in terms of external balance and internal fluxes. External balance of water refers to the balance between the water input from and the water output to the external environment. For internal stability, input and output should be kept equal. Under normal circumstances, both intake and output of water are subject to homeostatic regulation in the body. On the other hand, internal balance (or flux) refers to the movement of water across the capillaries, and between interstitial and intracellular fluids. In the human body there are several major fluid compartments each of which is subject to homeostatic regulation.

The largest compartment is the intracellular compartment, which is composed of at least 10¹⁴ separate tiny cellular packages. Any fluid not contained inside a cell therefore comprises the EC compartment. The IC and EC compartments are separated from one another by the plasma membrane of the cells. The EC fluid is contained within two compartments: the circulating compartment (the rapidly flowing blood plasma and the more slowly moving lymph fluid) and the interstitial compartments. The word “interstitial” literally means 'in the spaces', in this case, the spaces between the cells (http://www.liv.ac.uk/~petesmif/teaching/1bds_mb/notes/fluid/text.htm)

A 70 kg man contains about 40 liters of water divided into the different compartments as follows:

Table 7.1. Normal values of body water compartments (in liters)

Total 40	Intracellular 25	
	Extracellular 15	Interstitial 10.5
		Plasma 3
		Lymph 1.5

7.2.1.2. Basic Routes of Water Gain and Water Loss: Water intake in excess of requirements is excreted as urine, which also contains waste products including inactivated hormones and foreign substances. Urine is the only route of fluid loss which is under regulatory control for maintaining water balance. The other route of fluid loss is insensible losses, mostly water that we lose by evaporation from lungs and skin. It is termed

'insensible' as we don't sense this kind of water loss. The kidney is the major effector organ in excreting urine, and it turns out that volume of urine (about 1 ml/min) is so much smaller than that of plasma entering the kidneys each minute (about 650 ml/min). That means most of the filtered amount will be reabsorbed back by renal mechanisms. The ADH-urinary concentration mechanism will be explained in more detail in Sections 7.4 and 7.5.

Though ADH regulates the urine output by promoting concentration of urine; it cannot reduce the urinary water output below a minimum level. Therefore, an additional mechanism, i.e. thirst, is an integral part of the body water control. Thirst is a sensation of land animals, which is more insistent and tormenting than hunger and it may be defined as "the physiological urge to drink water". The thirst mechanism is integrated with the ADH-control mechanism. However, under usual conditions, most of the water intake is not due to thirst, since human beings mostly drink according to their tastes and habits. This is termed "secondary drinking", which is not a result of a real thirst sensation. Therefore, thirst functions as a backup effector mechanism.

7.2.2. Fundamental Approach and Assumptions

The total body water is contained within the numerous organs and tissues of the body. However, theoretically we can divide it into compartments to gain physiological insight and to predict some clinical measures. Thus, in this study we deal with idealized fluid compartments which in fact do not exist as real entities. However, these compartments have extremely important unifying similarities in terms of location, composition and behavior.

As mentioned before, the major division is into ICF and ECF which are separated by the cell membrane. Another significant portion of the body water (15 % of total body water) is contained in the fluid of bones and connective tissue; however this portion is excluded from this study since it is a kinetically slow compartment. The transcellular fluids which are small in volume are also ignored from the same reason. Consequently, this study only considers those parts of the total body water that are rapidly equilibrating. The other most important assumptions/rules related to the body water sector are as follows:

It is assumed that drinking, urinary excretion and insensible water loss need be considered in calculating changes in overall body water control. Digestion and excretion of food stuffs other than fluid and sodium ions, and the inflow of water gained by metabolic oxidation are excluded.

The model of the water-drinking mechanism developed by Reeve and Kulhanek (1967) forms the basis of the approach and assumptions regarding the drinking structure in this study. Accordingly, drinking is considered as a constant or variable rate mechanism governed by on-off switches and inhibitory feedback. The supposedly important effects of habit on drinking behavior are ignored.

The urinary sodium concentration and the sodium excretion rate are selected as the key indicators that affect the water excretion in urine. The underlying assumptions are: 1- The rate of water transport is always proportional to the rate of solute transport and 2-The urine flow is inversely related to the urinary concentration assuming a given sodium outflow (Bray et al., 1989). Other mechanisms, such as neurological and psychological influences, diurnal variation, etc. are not explicitly represented.

EC and IC compartments share the same osmolality. It is assumed that only water can move freely between the IC and EC compartments to equalize their osmolalities, since sodium and potassium are assumed to be locked in EC and IC compartments, respectively. It is assumed that water is transferred between the EC and IC compartments instantaneously to equalize their osmolalities, given the time units of the model.

The initial states and parameters are standard values which are quoted frequently in the major medical textbooks and in earlier models. When available, published experimental data is also used. The model assumes a standard healthy human male of approximately 70 kg with 40 liters of body water. The other factors causing variations in water content, i.e. variation due to age, sex and degree of obesity is ignored, and average values are used.

7.2.3. Description of the Structure

As mentioned before, total body water content is controlled by a negative feedback homeostatic mechanism which is often referred to by its effectors, i.e. the thirst-ADH mechanism. This mechanism maintains total body water within narrow limits of as little as ± 0.5 L. of a mean (Reeve and Kulhanek, 1967). Moreover, the distribution of the body water is also determined by this system. The structure constructed in this sector aims to simulate the dynamics of the TBW and its compartments, i.e. the EC and the IC compartments.

Stock flow diagram of the sector is given in Figure 7.4. Variables used in this sector are presented in Appendix B with their brief descriptions and units.

The structure used for this sector includes three stock variables. Two of these stocks represent the gut water and the body water, respectively. The third one is an artificial stock which represents the drink mode (continuous and discrete), and will be explained later. The only inflow of the gut water is drinking, which is defined as a constant or variable rate mechanism governed by on-off switches and inhibitory feedback. The water absorbed from the gut then will be distributed throughout the body. We assume that water transfer rate from the gut to the interior is proportional to the amount currently in the gut. The time constant to reach the interior body is selected as $\frac{1}{2}$ hours, according to the observation that there is a $\frac{1}{2}$ to 1 hour delay for all of the water drunk to become uniformly distributed in the body (Northrop, 2000).

Changes in the volume of TBW are the integral of all the rates of flow into and out of the compartment. The two inflows of TBW are `gut_to_in` and `water_infusion`. Water infusion flow is related to the treatment and will not be discussed here as the emphasis is on normal physiology. The two outflows of the TBW stock are insensible loss, and urine flow. Insensible loss refers to the amount of water lost by evaporation from lungs and skin including fecal loss. This rate is assumed to have a constant value of about 0,9 L/day (Reeve

and Kulhanek, 1967). Indeed, daily insensible loss has a fairly constant value, and exceptions to this average figure are uncommon.

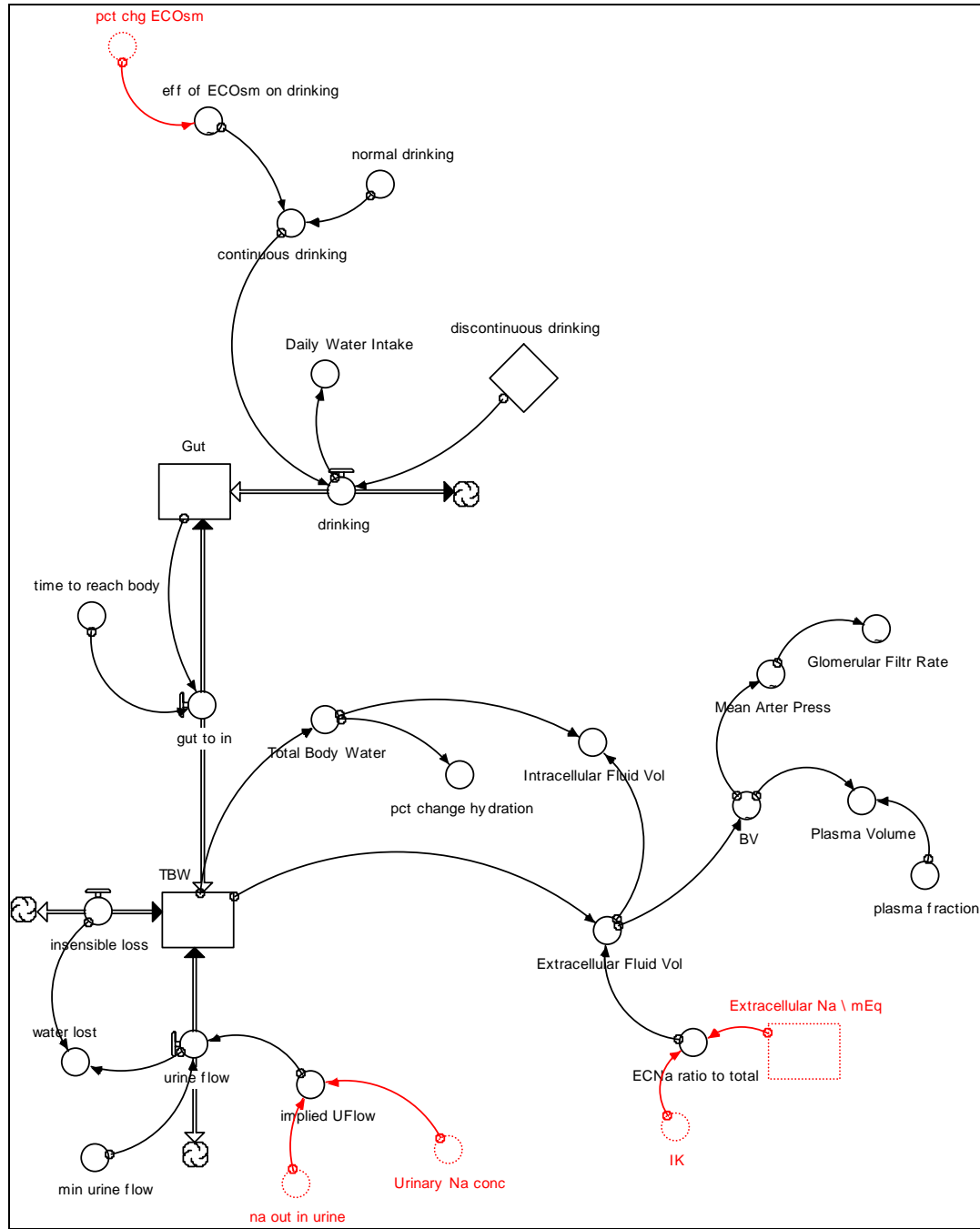

Figure 7.4. Stock-flow diagram of the Body Water Sector

The second outflow, i.e. the urinary water excretion, can be divided into a constant rate and a variable “free water excretion”. This constant rate or the `min_urine_flow` is referred as the obligatory urine loss, which is necessary to clear out the wasters of the body. Instead of defining two different values for the urine flow, only one flow is used, and the obligatory urine loss has been imposed as a constraint. Since the obligatory urine loss approximates 500 ml per day, the `min_urine_flow` is defined as 0,3 ml/min. Consequently, the equation for the `urine_flow` becomes:

$$urine_flow = MAX(min_urine_flow, implied_UFlow) \quad (7.1)$$

The urine flow rate is in turn determined by two variables, i.e. the urinary sodium concentration (`UNa_conc`), and the rate of sodium excretion (`na_out_in_urine`). The implied urine flow rate is linearly related to sodium excretion, as the rate of water transport is always proportional to the rate of solute transport. Accordingly, water excretion depends on sodium excretion, since H₂O ions passively follow Na⁺ ions, which are excreted by active transport (Bray et al., 1989). The equation of the `implied_UFlow` is depicted below:

$$implied_UFlow = \frac{na_out_in_urine}{UNa_conc \times 1000} \quad (7.2)$$

On the other hand, above equation depicts the inverse relationship between urine osmolality and urine flow rate. Ordinarily the urine flow rate*urine osmolality (which equals to the amount of solute excreted) is relatively constant and independent of flow rate, as mentioned before. Thus the kidney can adjust the urine flow rate without markedly affecting its handling of sodium, and the other solutes.

As mentioned before, the structure employed in this study considers drinking as the main source of fluid intake, and both continuous and discontinuous drinking options are modeled to simulate the drinking behavior of man. Discontinuous drinking of the model represents a switch-on and switch off structure, which only acts under some threshold body water level.

7.2.3.1. The Structure Related to Discontinuous Drinking: The drinking structure employed for discontinuous drinking is depicted in Figure 7.5. It is assumed that a fairly constant level of dehydration is necessary for the initiation of drinking. According to that, once the body water falls below a threshold level drinking starts. This lower limit (l_limit) is defined as follows:

$$l_limit = \frac{normal_TBW \times (100 - pct_chg_in_TBW)}{100} \quad (7.3)$$

It is observed that a decrease from 1 to 1.5 percent of body water is required to initiate drinking (Reeve and Kulhanek, 1967). Accordingly, loss of 1.25% of body water, i.e. 500 ml, changes the drink mode from 0 to 1 by using a switch function. The SWITCH function is equivalent to the following logic: If Input1 > Input2 then 1 else 0.

$$key_on_2 = SWITCH(l_limit, water_sensed_by_body) \quad (7.4)$$

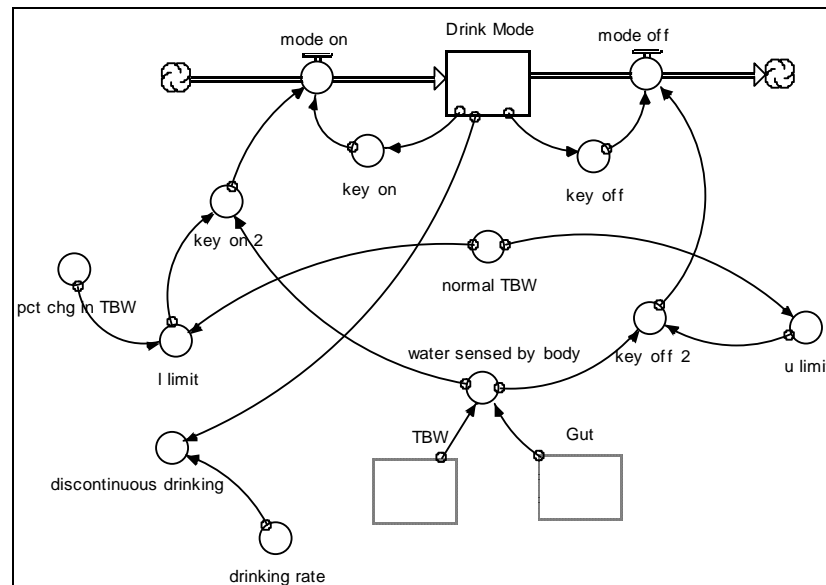

Figure 7.5. Discontinuous drinking structure employed in the model

The second assumption is related to the level of body water at which drinking ceases. We term this level as u_{limit} , and it is assumed to be equal to normal body water, i.e. just enough water is drunk to restore the body water and then the urge to drink disappears. This is a very important property reported by various studies (Toates et al., 1970; Guyton, 2000, Northrop, 2000). It is clear that the quantity of water to replace the water loss is rapidly drunk. On the other hand, there is an inevitable delay before the ingested water is absorbed and available to decrease the EC osmolality, which is in turn expected to cease drinking. So, it is considered that short term gastric and mouth inhibitions exist that prevent an over- ingestion of water, which might yield a hypotonic EC osmolality.

According to this mechanism, once drinking has restored body water content to its normal level, drinking does not start again until body water level has fallen to the lower limit, which will restart this cycle. According to the study of Reeve and Kulhanek (1967), drinking rate is fairly constant in man, and may be approximated by 10% of body water/hour.

7.2.3.2. The Structure Related to Continuous Drinking: For the continuous drinking structure, the drinking rate is defined as a value that may be deviated from its normal by changing levels of the EC osmolality (See Figure 7.4) A healthy 70 kg man ingests about 2,2 L water per day (Guyton, 2000), so this value is taken as the normal constant drinking rate. The frequency and extent of drinking is also much influenced by habit, however the habitual drinking is ignored in this study. The second most important factor that is known to influence drinking is the EC osmolality. However, the quantization of thirst sensation is a difficult issue and there are very few studies about drinking when compared with excretion of urine. Nevertheless it is observed that a simple linear correlation exists between thirst and EC osmolality.

The effect of EC osmolality on drinking rate is defined as a graphical function of percent change in EC osmolality from its normal (See Figure 7.6).

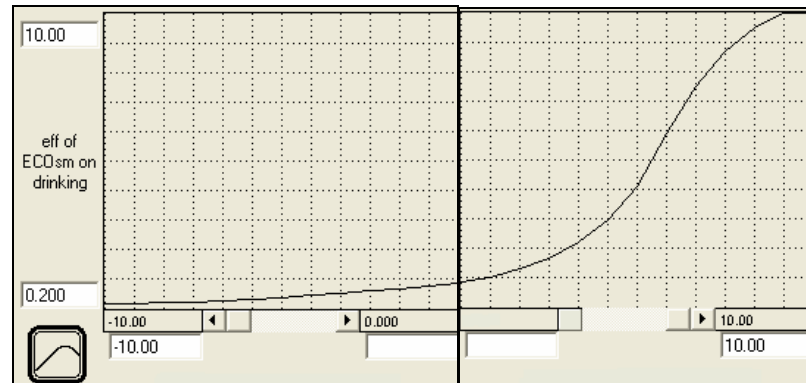

Figure 7.6. Effect of EC osmolality on drinking

7.2.3.3. Distribution of Body Water: Appropriate distribution of body water between the EC and IC compartments is another accomplishment of the water balance control mechanism. In the average adult human, about five eighths of the body fluids constitute the IC fluid, and three-eighths remain extracellularly, or 25 liters are IC fluid and 15 liters EC. Since the EC and the IC osmolalities are always identical, and IC solute is assumed to be constant, the EC fluid volume (ECFV) is calculated as follows:

$$ECFV = TBW \times ECNa_ratio_to_total / 1000 \quad (7.5)$$

$$ECNa_ratio_to_total = \frac{ECNa}{(ECNa + IK)} \quad (7.6)$$

As the EC fluid volume is calculated in this way, the IC fluid volume (ICFV) is found simply by subtracting the ECF volume from the TBW:

$$ICFV = Total_Body_Water - ECFV \quad (7.7)$$

BV is assumed to follow the ECF volume with a saturating curve. Normal ECF volume is about 15 liters, and that yields a BV of 5 liters under normal conditions. As depicted in the Figure 7.7, there is a nearly linear relationship between ECF volume and BV in the normal range. However, this occurs only until the ECFV reaches 20 to 25 liters.

Beyond this point, all the additional fluid that enters the ECF compartment enters the interstitial spaces. In this way, BV is maintained at a constant value at the expense of massive increases in interstitial volume, i.e. edema (Guyton and Coleman, 1967).

MAP is assumed to be a function of BV, and the GFR can then be well approximated by a sigmoid-shaped function of the MAP. GFR represents the amount of filtrate formed per minute and so it determines the amount filtered for any substance in the kidney. GFR is very large (180 liters/day) in comparison to the amount of urine that is typically produced (approximately 1,5 liters). Therefore the stability of GFR is extremely important to optimally filter the blood and reabsorb water and ions at their normal rates. Under normal conditions, up to 95% of blood and ions in the filtrate are reabsorbed. The graphical functions of MAP and GFR are given in Figures 7.8 and 7.9.

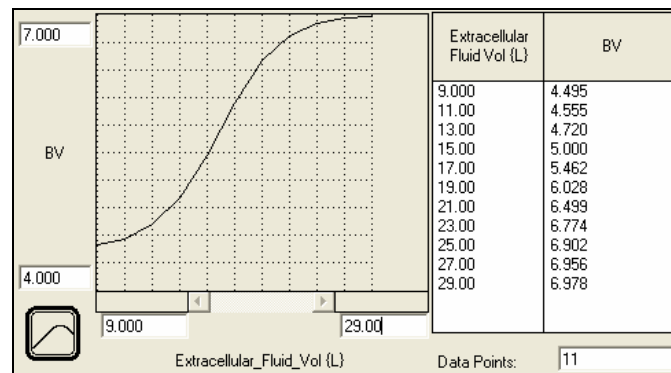

Figure 7.7. Blood volume as a function of ECF volume

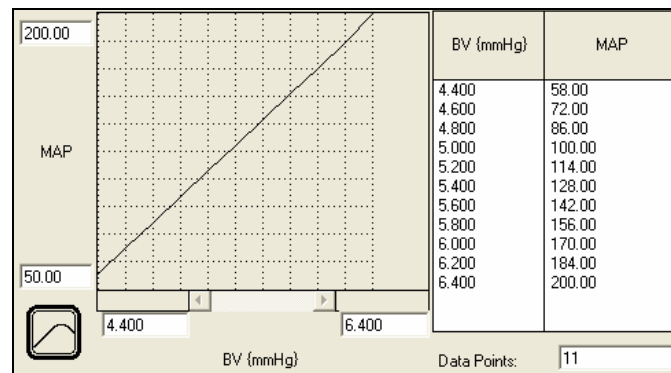

Figure 7.8. Mean arterial pressure as a function of blood volume

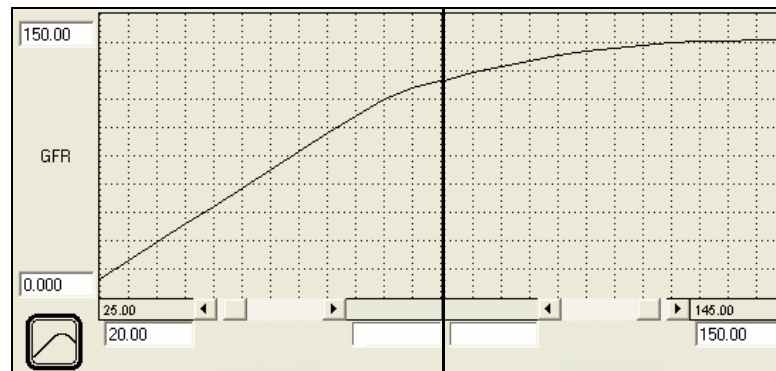

Figure 7.9. Glomerular filtration rate as a function of mean arterial pressure

7.2.4. Dynamics of the Body Water Sector in Isolation

The body water sector is isolated from other sectors and the behavior of the body water and its compartments are studied under two different types of water infusion. In the first case, a pulse water input of 1000 ml is given at time 0 (See Figures 7.10, 7.11 and 7.12). Total body water is increased by 1 liter almost after the first hour, as expected. Its outflows, i.e. the urine flow and the insensible losses stay constant and cannot change in this experiment. On the other hand, the gut water is suddenly increased and then it gradually approaches to its initial steady-state level. In this case, drinking is constant and the water transferred from gut to the interior of the body also gradually approaches to its steady-state value.

In the second experiment, a continuous step water input of 100 ml is given at time 0. (See Figures 7.13 and 7.14). After 4 hours, total body water is increased almost by 400 ml, and continues to increase, as expected. The urine flow, the insensible losses and drinking stay constant as in the former case, but the amount transferred from the gut and the gut water reach a higher steady-state value.

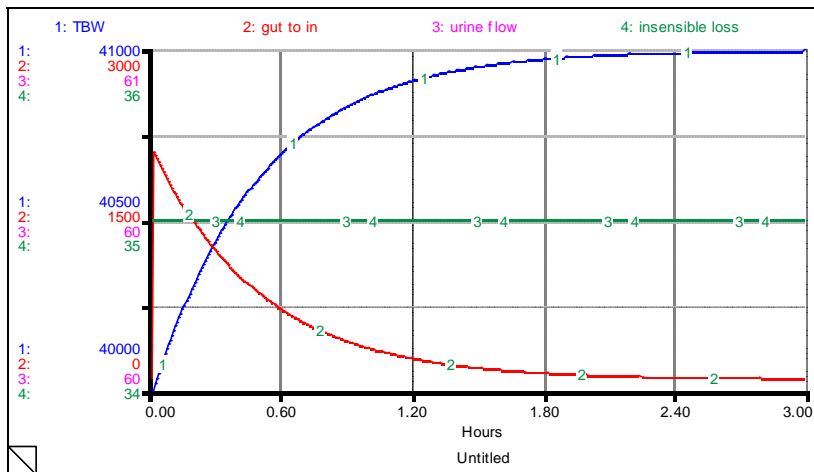

Figure 7.10. Total body water and related flows in isolated sector run with a pulse of water infusion

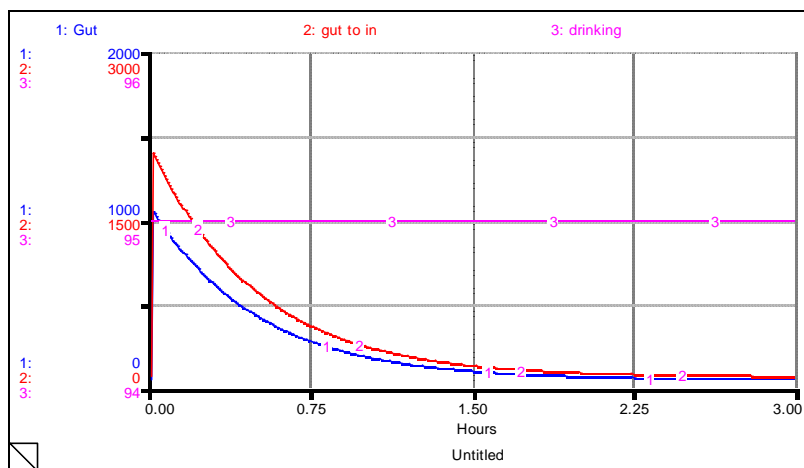

Figure 7.11. Gut water and related flows in isolated run with a pulse of water infusion

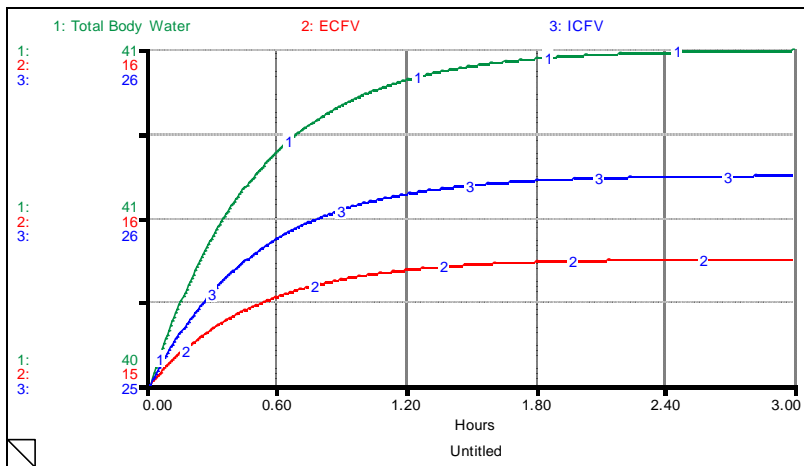

Figure 7.12. Body water compartments in isolated run with a pulse of water infusion

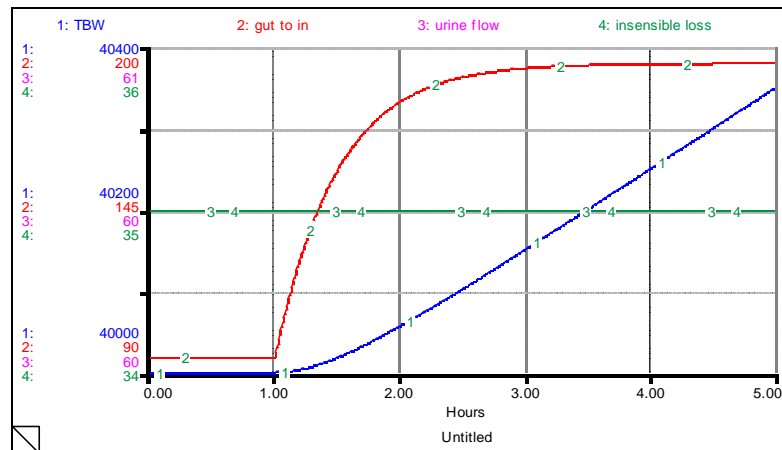

Figure 7.13. Total body water and related flows in isolated sector run with a step water infusion

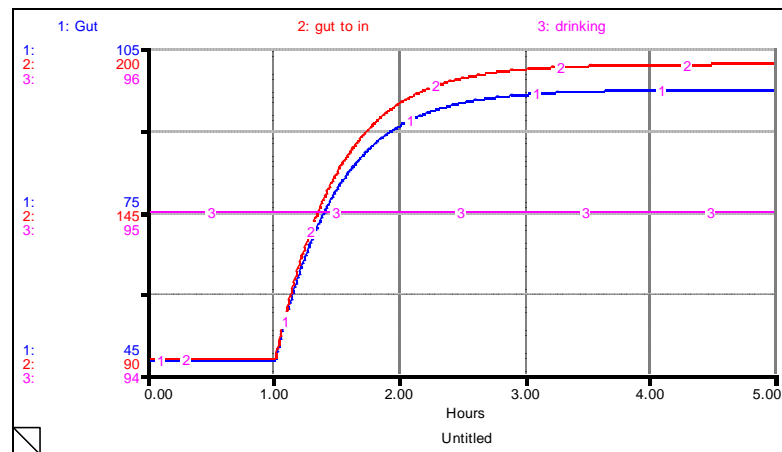

Figure 7.14. Gut water and related flows in isolated run with a step water infusion

7.3. Sodium Sector

7.3.1. Background Information

7.3.1.1. Sodium: Sodium (Na^+) is an essential electrolyte of the human body, which exists in blood, lymph, interstitial fluids, cerebrospinal fluid, sweat, tears, saliva, gastric secretions, intestinal and pancreatic juices, bile, urine, cartilaginous matrix, and bone (Guyton, 2000). However, only a part of this Na^+ is “mobile” and this part is contained in the EC fluid solution. As the major cation of the EC fluid, sodium is also the principal determinant of the total ECFV. For about every 150 mEq change in sodium, there will be a

corresponding change of 1 liter in ECFV. Indeed, the human body regulates the ECFV by regulating its Na^+ content.

The ECNa “concentration” is also rigorously defended by the body. In fact, it is the “osmolality” of the EC fluid that is monitored by the control system, which represents the number of particles in a given mass of water, usually expressed as millimoles (or milliequivalents) per kilogram of water. However control of EC osmolality is almost the same thing as the control of ECNa concentration, since ECNa is the substance that mostly contributes to the EC osmolality with its accompanying anions, chloride and bicarbonate. It should be noted that the mechanisms that control the ECNa “concentration” and the ECNa “amount” are different, albeit interacting. The mechanism that regulates the ECNa concentration is referred to “ADH-thirst mechanism” and is outlined in Section 7.1.1.

7.3.1.2. Potassium: Potassium (K^+) is the chief IC cation of man, and it is the major determinant of cellular hydration and resting potential. There is about 3500 mEq K^+ in the body, of which only 60 mEq is in the EC fluid. K^+ ions are involved in many activities, e.g. in the activities of muscle, nerve and gland cells, and an almost constant EC K^+ ion concentration is required for proper function of many enzymes. The IC concentration (100-150 mEq/L) is not very important but a two- or threefold increase or decrease in the EC concentration (4-5 mEq/L) can paralyze muscles or lead to cardiac arrest. Lectures on human physiology. The distribution of sodium and potassium is an important factor for the body water distribution, and their respective amounts is also monitored and defended by some hormonal or renal mechanisms.

7.3.2. Fundamental Approach and Assumptions

Maintenance of normal ECNa and thereby a normal ECFV requires a refined intake and excretion for Na^+ ions. However related literature suggests that the regulated component has to be the sodium excretion, since regulation of intake, i.e. the sodium appetite regulation, mostly depends on habits rather than the requirement in modern societies and is almost always greater than necessary for homeostasis. Moreover, the

mechanism for regulating intake are less understood and quantized. Therefore, the sodium intake rate is assumed to be constant in the model and no behavioral changes are allowed.

For any substance, the amount of excreted in the urine is the algebraic sum of the amounts filtered, reabsorbed and secreted by the tubules. As regarding sodium, only filtration and reabsorption do exist since sodium is not secreted by tubules, e.g. unlike potassium. The structure used in the model formulates sodium excretion rate as a value which may deviate from its normal according to some factors, instead of first finding the filtered amount and then subtract the reabsorbed portion. Sodium excretion is affected by various factors; however only the most important ones, i.e. the GFR (which affects the filtered load of sodium), the RAAS, plus the recently found ANH are explicitly represented in the model. Other factors including the activation of the sympathetic nervous system, which is indicated to have an important effect on sodium dynamics, is omitted and considered to be constant. Moreover, sodium excretion rate is formulated to be independent of urine flow, since neither the rate of solute reabsorption nor the total quantity of solute in ECF is altered by changes in reabsorbed water. The importance and implications of this feature will be explained in Section 7.5 in more detail

Another assumption is related to the distribution of sodium in the body. Most of the mobile sodium that can vary in amount from day to day resides extracellularly, and only a small portion resides in the cells. Another large amount is further contained in the bones; however, this part does not contribute to the osmolality of the body fluids. As a result of these, it is logical to assume that sodium is locked to the EC compartment. Similarly, the major intracellular cation, i.e. potassium, is assumed to be locked to the intracellular compartment, since only a small portion of potassium resides outside of the cells. Furthermore, the amount of potassium is assumed to remain constant and cannot be changed purposely, unlike the amount of sodium, which can be changed by addition or removal of solute. The assumption that intracellular solute is constant is not always correct but these special circumstances do not greatly detract from the general conclusion.

The second group of assumptions is associated with the “concentration” or “osmolality” of sodium. First thing we have to note that it is the “tonicity”, and not

“osmolality”, which is the right term in the medical context. In fact, tonicity may be defined as the effective osmolality and is equal to the sum of the concentrations of the solutes which have the capacity to exert an osmotic force across the membrane, and the implication is that tonicity is less than osmolality. Therefore whenever we use “osmolality”, we mean “effective osmolality”, or “tonicity”.

One of the most important rules regarding the body fluids is that the EC and IC fluid osmolalities (ECOsm and ICOsm) are always identical. In the model it is assumed that the ECOsm is always proportional to EC sodium concentration and the ICOsm is proportional to IC potassium concentration (Guyton, 2000). This is a logical assumption since sodium ions of the ECF determine over 90 percent of the osmotic pressure of the ECF. The contribution of two other solutes, glucose and urea, normally represent only 3 percent of the total osmolality, and thus they are omitted. Consequently, the terms “control of sodium concentration” and “control of osmolality” can be used at the same time and interchangeably.

7.3.3. Description of the Structure

As mentioned before, regulation of sodium, water, and hormonal balances are inextricably interdependent. However in this study they are constructed as single sectors to increase readability. The structure constructed in this sector aims to simulate EC sodium (ECNa) and the EC sodium concentration (ECNa_conc) dynamics which in turn have profound effects on the body water distribution and the ECF volume.

Stock flow diagram of the sector is given in Figure 7.15. Brief descriptions of the variables used in this sector are presented in Appendix B.

The structure used for this sector includes only one stock variable, which represents the ECNa. This stock has a single inflow representing the normal sodium intake (na_intake). As mentioned before, most people eat far more sodium than is necessary, which usually ranges between 100 and 200 mEq/day. Accordingly, na_intake is defined as a

constant value of 7,5 mEq/h or 180 mEq/day. So, sodium intake is constant under normal conditions, but it can be changed on purpose.

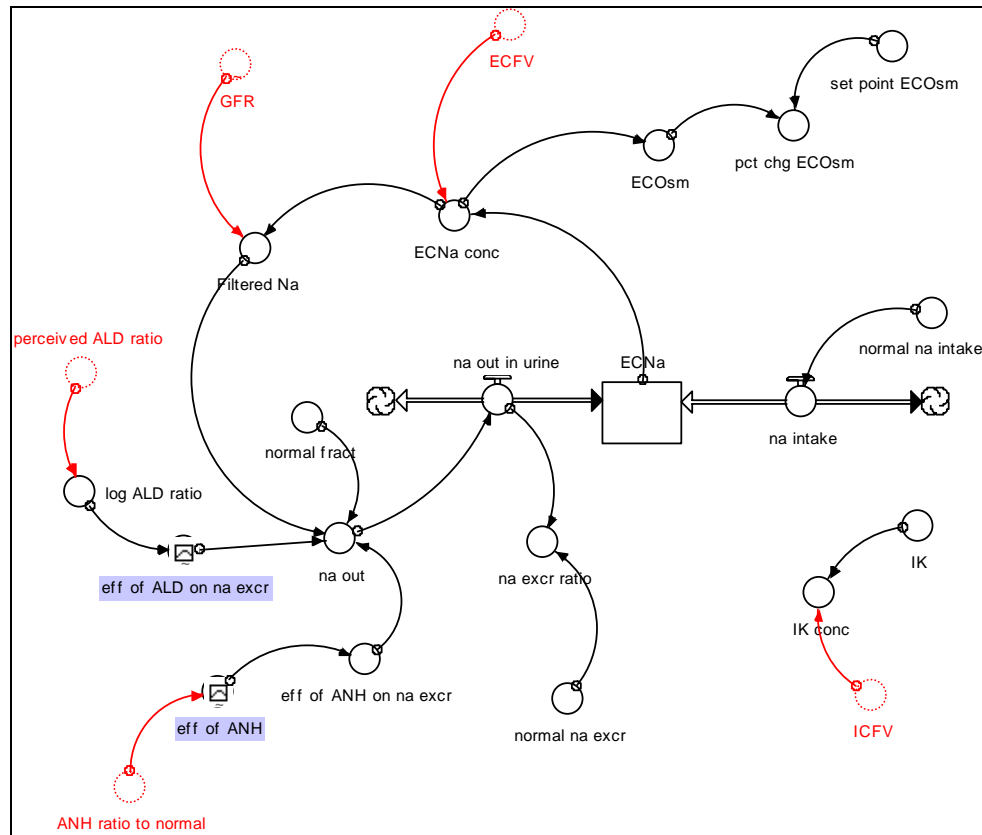

Figure 7.15. Stock-flow diagram of the Sodium sector

Single outflow from the ECNa stock is the sodium excretion in urine (*na_out_in_urine*) and its value is highly variable due to homeostatic regulation. The factors determining sodium excretion in this study can be divided into three groups: Factors regarding the filtered load of sodium (*Filtered_Na*), i.e. the GFR and the EC sodium concentration (*ECNa_conc*) and ALD and ANH. If hormonal effects were not present, still an increase in body sodium will lead to an increase in urinary sodium excretion via the glomerular filtration mechanism. According to that, the equation for the *Filtered_Na* is defined as:

$$Filtered_Na = GFR \times ECNa_conc / 1000 \quad (7.8)$$

With a GFR of 125 ml/min and an ECNa concentration of 142 mEq/L, the filtered load of sodium will be 17,75 mEq/min or 25560 mEq per day. It is clear that changes in GFR or ECNa concentration will change the sodium load presented to the kidney. Under normal conditions, 99% of the filtered sodium is reabsorbed back to blood. Therefore the filtered load is multiplied by a normal fraction to find the normal sodium excretion rate that will keep the ECNa stock constant under steady-state conditions.

The effects of ALD and ANH on sodium excretion are formulated with graphical functions (See Figures 7.16 and 7.17) with reference to their normal concentrations. Hormone concentrations can be considered as intermediate variables for the purpose of this study, and thus their concentrations need not be known in absolute terms but may be specified with reference to normal, when trying to find their effects on water and sodium excretion. Since the effects of ALD hormone take about one hour to become apparent, the perceived ALD hormone concentration with reference to its normal (perceived_ALD_ratio) is used instead of the instant value of the ALD concentration. The final effect of ALD on sodium excretion is then defined as a graphical function of the logarithm of perceived_ALD_ratio, since the effects of ALD are logarithmic in nature (Coleman and Hall, 1992).

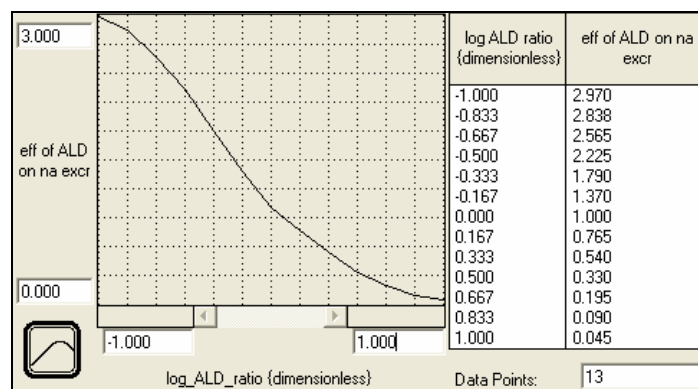

Figure 7.16. Effect of Aldosterone on sodium excretion

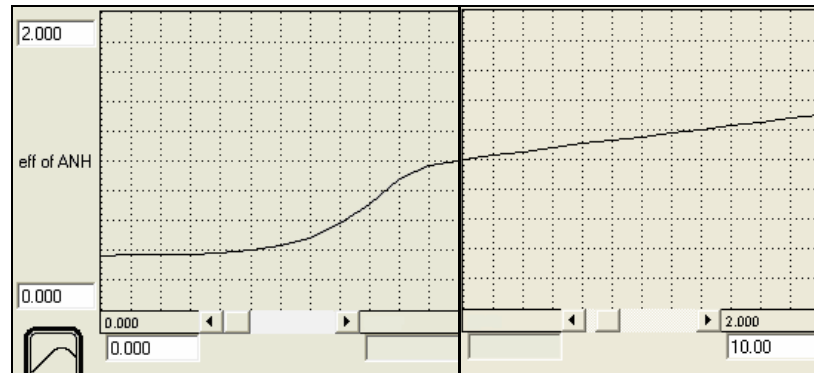

Figure 7.17. Effect of Atrial Natriuretic Hormone on sodium excretion

Studies about the ANH effects on electrolyte excretion (Janssen, 1994, Cogan et al., 1988) indicate that there is an apparently clear dose-effect relationship between ANH levels and sodium excretion rate. Based on these data, the effect of ANH on sodium excretion is defined as a graphical function which may be seen in Figure 7.17.

Finally, $na_out_in_urine$ is represented by a multiplicative effect formulation:

$$na_out_in_urine = Filtered_Na \times normal_fract \times eff_of_ANH_on_na_excr \times eff_of_ALD_on_na_excr \quad (7.9)$$

The unit of this equation is in [mEq/min], and has to be converted to hours since the time unit of this simulation is selected as hours. Thus the final value of the sodium excretion is multiplied by 60.

Another important variable represented in the sodium sector is the $ECNa_conc$, which has a normal value of 142 mEq/L. The $ECNa_conc$ is found by division of EC sodium content (ECNa) by ECFV. Especially the ADH mechanism is very sensitive to any change in $ECOsm$ and takes action in just a few minutes. Since sodium and its associated ions normally account for about 94% of EC tonicity (Guyton, 2000), the $ECOsm$ can be roughly estimated as: $ECNa_conc \times 2.1$, as Guyton suggested. Accordingly, the normal $ECOsm$

would be estimated from the formula above to be about 298 mEq/ L, which is defined to be the “set-point” for the ADH-thirst mechanism that controls the EC osmolality.

As mentioned before, the EC and the IC osmolalities are always identical after any quick transients have passed. Since the amount of potassium (K) does not change in this study, this quantity is represented simply by its normal physiological value of 3550 mEq, and the IC_{OSm} is taken as being proportional to intracellular potassium concentration (ICK_conc). Similar to the EC_{Na} concentration, the ICK_conc is found by division of IC potassium content (ICK) by ICFV.

7.4. Endocrine System Sector Group

7.4.1. Background Information

The work of Guyton (2000) states that the functions of the body are regulated by two major physiological systems: 1-the nervous system and 2-the endocrine (or hormonal) system. Whereas the nervous system has a response time on the order of milliseconds, the hormonal system shows a wide range of response time in exerting its functions. Hormones are generally present in minute concentrations and are carried to their target organs in the body by the circulatory system. Under usual circumstances secretion rates of all hormones are under negative feedback loop control. The fact that the body water is a general denominator in determining the electrolyte concentrations makes the hormonal system more complex to understand (Northrop, 2000).

The kidney is the common site of action of these hormones, through which solutes and water are excreted at variable rates, sometimes independently (Guyton, 2000). As a consequence of this, hormonal functions are intimately interrelated through the functions of the kidney, which plays a major role in the operation of all endogenous and hormonally governed ionic regulatory systems. The major hormones regulating sodium and water balance are the ADH, RAAS, and the more recently found ANH.

7.4.1.1. Antidiuretic Hormone (ADH): ADH is a neurohypophyseal hormone, which is synthesized in the hypothalamus and deposited in the posterior pituitary gland as secretory granules. It is known to play a major role in the regulation of water conservation in the body. ADH is also often termed “vasopressin” due to its vasoconstrictive properties at pharmacological high doses, and may also play a role in learning; memory and stress response of the body. In the kidney, ADH exerts its function by increasing the permeability of water in the nephrons, i.e. by promoting concentration of urine, and thus can control the reabsorption of up to 10% of the filtered water (up to 10-20 liters per day!). Under normal conditions, a change in ADH level immediately causes a change in urine flow and osmolality (DeHaven and Shapiro, 1967). Figure 7.18 gives a schematic representation of the normal physiologic relationships among EC osmolality (EC_{OSm}), AVP (or ADH) concentrations, urine osmolality (U_{OSm}), and urine volume. Accordingly, U_{OSm} is proportional to plasma ADH levels, but urine volume is inversely related to urine osmolality.

ADH deficiencies result in production of large amounts of urine that is maximally dilute, a condition called Diabetes Insipidus (DI). On the other hand, excessive or inappropriately high ADH levels result in water retention and development of water intoxication/hyponatremia. The disorders related to ADH secretion and actions are explained in Section 3.2.

The most important factors regulating ADH secretion are EC osmolality and effective circulating blood volume. In contrast to the simple linear correlation between EC osmolality and circulating ADH levels, the volume-ADH relationship is exponential, and may override the osmotic effects in some conditions (See Figure 7.18). However blood volume decreases in the order of 5 to 10 percent are necessary in order to activate the volume receptors, whereas the osmoreceptors are sensitive to very minute changes in EC osmolality (Verbalis, 2003). The renal response to ADH is also similarly linear, since urinary concentration is proportional to ADH levels. However a greater level of osmolality and subsequent ADH release fails to increase urinary concentration when a certain threshold is reached. In healthy individuals, this failure is compensated by the stimulation of thirst, and a potential water deficit will be replenished. As a result, the rate of water intake and excretion is

accurately regulated to maintain an almost constant EC osmolality. The whole system for control of water balance, which is frequently referred as “ADH-thirst mechanism” is outlined in Section 7.1.1.

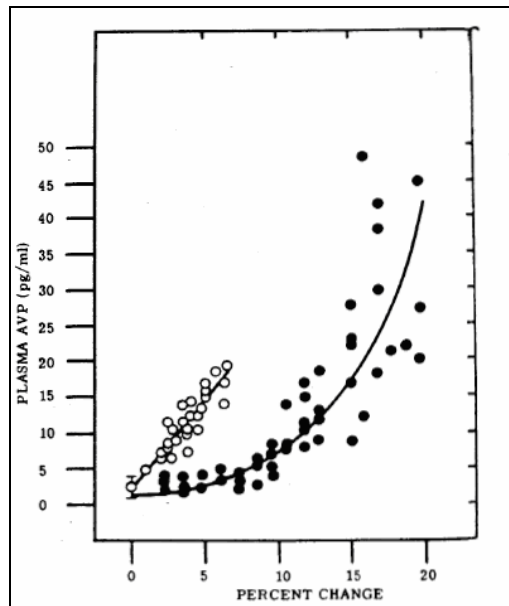

Figure 7.18. Relationship of plasma ADH to percentage increase in EC osmolality (white circles) and percentage decrease in blood volume (black circles) (From Dunn *et al.*, 1973).

7.4.1.2. Renin-Angiotensin-Aldosterone System (RAAS): The RAAS plays a major role in the regulation of sodium and potassium balance and the arterial blood pressure. RAAS is able to control these three functions against wide variations in sodium and potassium intake by continuously regulating its effector hormones, ANG and ALD (Laragh, 1985). Activation of the RAAS causes increased sodium retention, which also leads to reduced water loss and increased blood volume. Therefore, anything that influences the activity of the RAAS will alter the blood volume and the arterial blood pressure. The close association of RAAS to arterial pressure drew also strong attention of the researchers of hypertension, since it is known that RAAS may be a prime contributor to hypertension if activated inappropriately (Navar, 1997).

Under normal conditions, a decrease in blood volume and/or pressure stimulates the secretion of a renal hormone in the kidney that is called renin (Weir and Dzau, 1999). Once

in the blood stream, renin catalyzes a chemical process which ends with the production of angiotensin II as an end product. ANG causes the kidneys to retain salt and water, both by direct and indirect mechanisms. The indirect effect is mediated through ALD, a hormone synthesized by the adrenal gland, for which release of angiotensin II is known as the most potent direct stimulus (Other factors for ALD secretion are diminished EC sodium concentration/sodium depletion, and increased EC potassium concentration). The second mechanism is a direct effect on the kidneys, to cause reabsorption of sodium, and thus also osmotic absorption of water.

In spite of its importance in sodium regulation, ALD is not the most important factor to renal sodium excretion and thus EC fluid volume regulation, as supposed before. Administration of excess amounts of ALD to a normal person produce salt and water retention, but only for a finite period, after which “escape” from the effects of ALD occurs and salt and water balance is maintained (Schrier and Niederberger, 1993). It is believed that this escape mechanism accounts for the fact that patients with primary aldosteronism (due to excess ALD levels) do not exhibit edema. The escape mechanism is considered to be mediated by the “third factor”, namely by the ANH, which is explained below.

7.4.1.3. Atrial Natriuretic Hormone (ANH): Changes in sodium excretion, which could not be explained either by changes in GFR or the ALD, were formerly attributed to an unknown “third factor”, since it was seen that in the absence of change in both of these conditions, saline loading was associated with an increase in sodium excretion. It has become clear that this third factor is the ANH, which is secreted from the atrial tissue. The main factor for ANH secretion is a rise in body fluid volumes, caused in a number of different ways, but particularly by saline infusion Schrier et al., 1993, Yamasaki et al., 1988, Cogan et al., 1988). This suggests that the distribution of water between EC and IC compartments is also important in mediating secretion of ANH (Cameron, 1977), and thus one important function of ANH could be to shift EC fluid from an overfilled vascular subcompartment to the interstitial spaces in order to maintain a constant blood volume.

7.4.2. Fundamental Approach and Assumptions

Despite the intimately coupled relationships between sodium and water balance, we can still classify their hormonal regulators as to their most important function. Accordingly, the most important regulator of the water balance is the ADH-thirst mechanism, which is studied extensively. This mechanism mainly controls the EC sodium concentration, and therefore the distribution of body water between the compartments, as will be explained in subsequent sections. However the regulation of sodium, i.e. the EC fluid volume regulation, is less understood due to its complexity as to the water metabolism, and hormones that affect sodium metabolism have been the focus of various investigations during this century. In this study, the RAAS and the ANH are modeled as effector hormones of sodium excretion, since their most important effect is on the sodium metabolism. These hormones are also termed as “volume hormones”.

The main assumption related to the hormone sector is that the controllers, i.e. hormones act according to set point theory. This assumption states that the rate of change of all hormones is brought by deviations from set points. In this study, the set point is defined in terms of concentration, i.e. the mechanism does not simply a change the “value” of the corresponding hormone, but its “concentration”, since hormonal effects depend on concentration rather than the absolute value.

Under normal conditions, all hormones are subject to diurnal variation, i.e. their blood concentration fluctuates during the day. For example, ADH concentration in plasma fluctuates with a maximum late at night and in the early morning and a minimum in the early afternoon. This feature may be important while interpreting a hormone level, or when prescribing a drug for the patient. Moreover, neurological and psychological influences may also have important effects on hormone concentrations, even when any other thing seems to be normal in the water and sodium balance. In this study, the diurnal variation, and neurological and psychological influences are not explicitly represented and were considered to be constant.

Another important assumption relates to the response time of the hormones. The responses of ADH and ANH are assumed to take effect immediately, however ALD responds to the value of stimuli after a delay. Therefore, ALD is important for long-term rather than minute-to-minute adjustments of sodium excretion (Bray et al., 1989), whereas ANH (together with changes in filtered load) is responsible for short term adjustments in sodium excretion.

In this study, the RAAS is assumed to have only one effector hormone, namely the ALD hormone. ANG is only considered as a hormone that stimulates ALD production. Indeed, ANG is one of the most important determinants of ALD production; however ANG itself also has been shown to regulate the rate of sodium reabsorption, independent of ALD. In this study, the effects of ANG and ALD are lumped together and only the ALD effect is represented explicitly.

Factors that cause secretion of hormones are also subject to controversy, and most of the time the interdependence of water and sodium metabolism may blunt the real cause and effect relationships between stimuli and response. Therefore quantitative results may vary significantly between studies which are taken under different conditions and/or set of assumptions. The factors chosen to effect hormone concentrations in this study will be explained one by one in the next section.

7.4.3. Description of the Structure

The hormonal sector group is composed of three sectors, which are the ADH, RAAS, and ANH. The structure constructed in these sectors is mainly responsible for simulating the dynamics of the major hormones that are responsible for differential excretion of body water and sodium ions.

All of these three sectors are mainly influenced by the feedbacks from the sodium and body water sectors, and their output in turn determines the two most finely regulated determinants of body water-electrolyte balance, i.e. the urinary concentration and the

sodium excretion rate. Changes in ADH allow the kidneys to play with the urinary concentration to adjust the total body water balance, and the other two hormones, namely ALD and ANH; influence the sodium excretion rate which is mainly associated with the blood volume control. Therefore, the ADH is mainly known as a water balance controller, whereas the RAAS and ANH are known sodium balance controllers.

Brief descriptions of the variables used in this sector are presented in Appendix B. Stock-flow diagrams and graphical functions will be presented below.

7.4.3.1. The Structure Related to the Antidiuretic Hormone: The structure used for this sector is inspired by the study of the DeHaven and Shapiro (1967). However certain parameters and structures are modified according to the requirements of this study. This sector includes two stock variables as seen from the stock-flow diagram (See Figure 7.19). One of these two stocks represents the storage pool (ADH_Pool), and the other one represents the available ADH level in plasma (ADH_in_Plasma). The ADH_Pool is adjustable, and the pool capacity (pool_cap) may be defined as a percentage of the maximum pool capacity (max_pool_cap) (See Equation (7.10)). This will allow the user to simulate the effects of the ADH storage on body water dynamics, which will be useful in simulating Diabetes Insipidus (DI) dynamics.

$$pool_cap = \frac{max_pool_cap \times (100 - pct_decrease_in_cap)}{100} \quad (7.10)$$

The rate of ADH input into the pool (ADH_production) is affected by the current ADH level in the pool and reduces when the pool approaches its capacity. The effect of capacity on ADH production is formulated with a graphical function (see Figure 7.20) using ADH pool divided by the pool capacity.

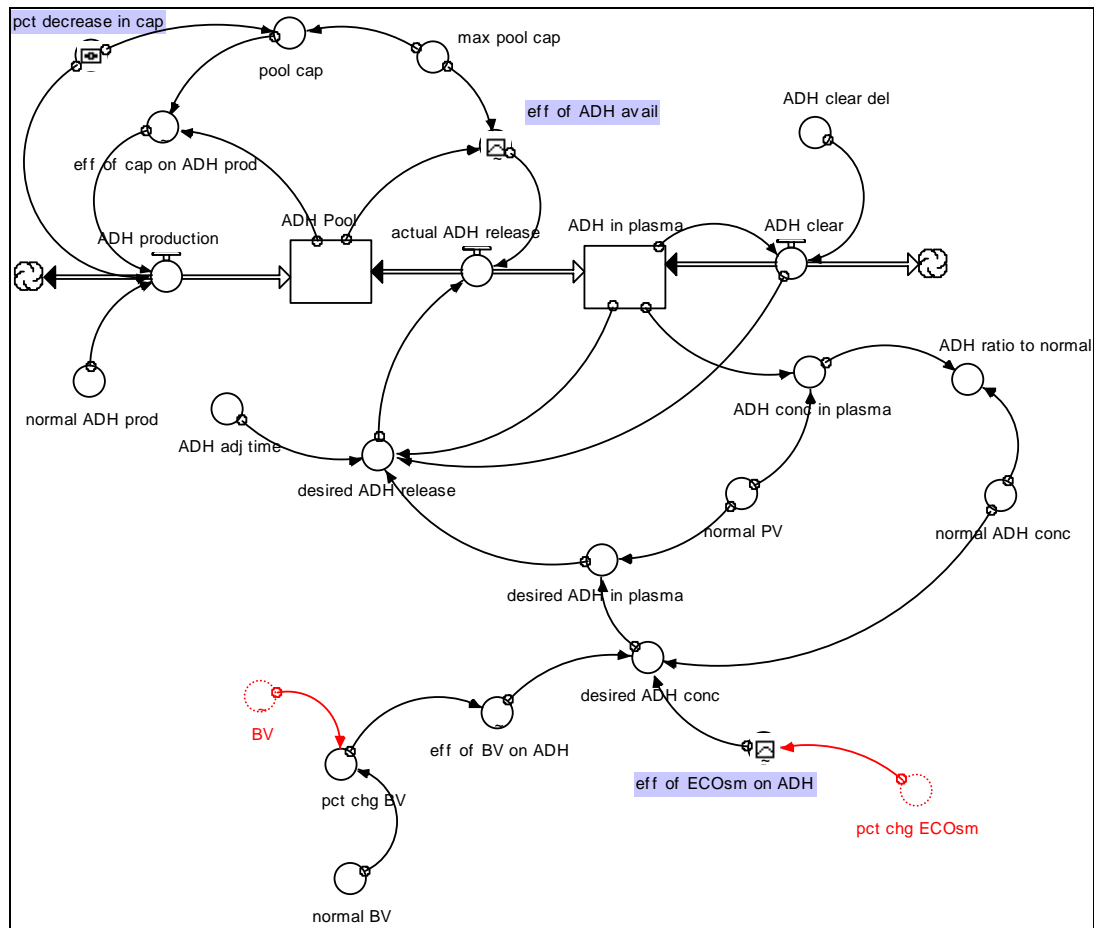

Figure 7.19. Stock-flow diagram of the ADH sector

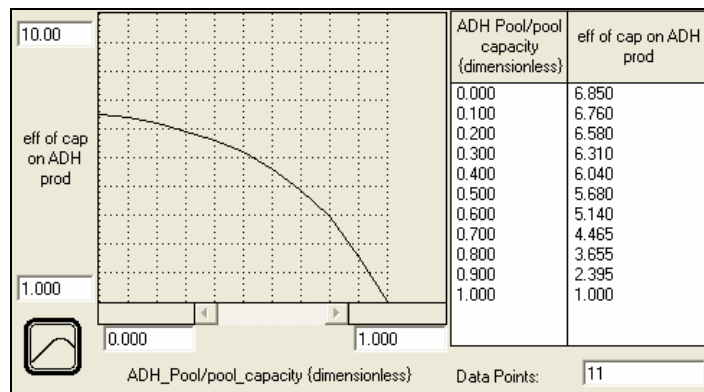

Figure 7.20. Effect of ADH pool capacity on ADH production

The rate that ADH leaves the pool and enters the blood is determined by the desired ADH release, but it is also limited by the availability of ADH. This is in concordance with the observation that ADH release begins to decline when about 10% of the pituitary store of

the hormone is depleted. It is observed that, only 10 or 15% of the ADH secretory granules are readily available to release ADH, as some ADH-containing secretory granules migrate from the nerve endings as a result of an aging process and their contents become unavailable for release. The effect of ADH availability (ADH_avail) is defined as a graphical function of the ADH_Pool divided by the max_pool_cap.

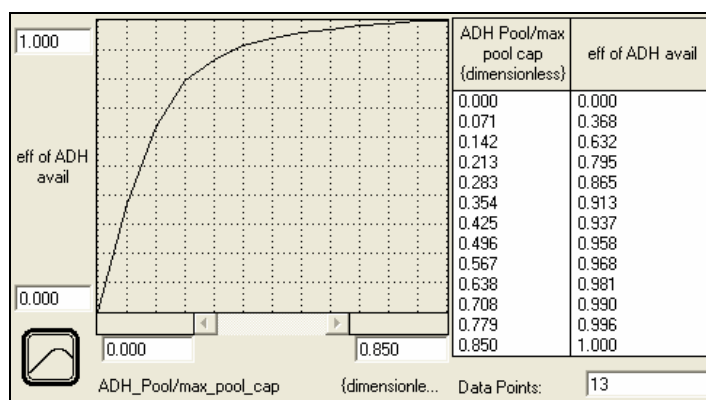

Figure 7.21. Effect of ADH pool on ADH availability

Since the pituitary stores are high when compared to the normal requirements, it is assumed that a very large percentage of the stores have to be depleted for the release rate to slow down severely. This coincides with the observation that the effects of DI do not appear in a patient who has still a partially intact ADH pool. The effects mostly appear after a permanent loss of 80% of the secretory granules. Finally, it is assumed that ADH is inactivated at a rate proportional to its concentration, according to the simple first-order kinetics. The active half-life of ADH varies between 6-20 minutes, before it is cleared irreversibly from the body. In this study, the half-life is selected as a constant of 15 min, or 1/4 hours.

At the physiological set point of EC osmolality (298 mEq/L), the concentration of ADH in plasma is 1 to 2 pg/ml. Accordingly, the “normal” ADH concentration is selected as 2 pg/ml. This concentration can vary widely, depending on circumstances. Under conditions of random fluid intake, circulating ADH levels range from 0.5 to 6 pg/ml, and the urine osmolality is maximal at the latter plasma level and above.

The two most important causal factors that determine the ADH concentration are ECOsm and BV. It is assumed that stimuli acting on ADH secretion do so as an additive sum, as suggested by the related literature (Toates, 1977), and the desired ADH level (*desired_ADH_conc*) is defined as:

$$\begin{aligned} \text{desired_ADH_conc} = & \text{MAX}(0, \text{normal_ADH_conc} + \\ & \text{eff_of_ECOsm_on_ADH} + \text{eff_of_BV_on_ADH}) \end{aligned} \quad (7.11)$$

As osmotic stimuli are known to produce linear increases in ADH release, the effect of ECOsm on ADH secretion (*eff_of ECOsm_on ADH*) is defined as an almost linear function of the percent change in ECOsm from its normal.

$$\text{eff_of_ECOsm_on_ADH} = f(\text{ECOsm}), \text{ where} \quad (7.12)$$

$f(\text{ECOsm})$ is given in Figure 7.22.

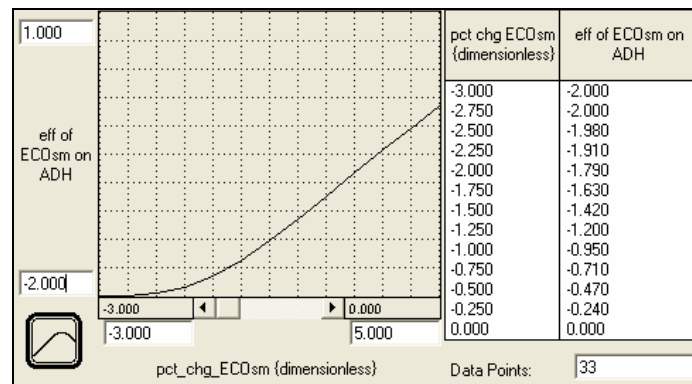

Figure 7.22. Effect of EC osmolality on ADH secretion

As depicted by the graph, the ADH osmoreceptors are sensitive to a 1-2% change in ECOsm from its normal and so, osmotic stimuli produce abrupt changes in ADH release (<http://www.anaesthesiamcq.com/FluidBook/index.php>). On the other hand, the threshold of the volume receptors for causing changes in ADH secretion is a 7 to 10% change in blood

volume, i.e. nonosmotic ADH release is negligible so long as BV is normal. But with BV depletion of greater than 10%, plasma ADH concentrations rise in a near-exponential fashion. It is observed that BV loss greater than 25% will cause a 20-to 50-fold increase in the rate of ADH secretion (Guyton, 2000). It can be safely concluded that hypovolemia (reduced blood volume) is a more potent stimulus for ADH release than is hyperosmolality. Consequently, a hypovolemic stimulus to ADH secretion can override a hypotonic inhibition and volume will be conserved at the expense of osmolality.

As mentioned before, it is assumed that the “level” and not the absolute “value” of hormones are regulated. Accordingly, the amount of desired ADH is found by multiplying the desired ADH concentration by the plasma volume. Afterwards, *desired_ADH_release* is formulated by the equation given below:

$$desired_ADH_release = MAX(0, \frac{(desired_ADH_in_plasma - ADH_in_plasma)}{ADH_adj_time} + ADH_clear) \quad (7.13)$$

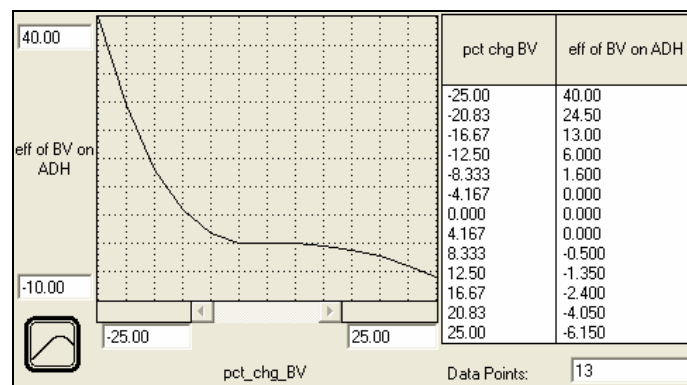

Figure 7.23. Effect of blood volume on ADH secretion

The adjustment time for the release of ADH is taken as a constant value of 10 minutes, or 1/6 hours.

The causal-loop diagram in Figure 7.24 summarizes the causal relations embedded in the ADH system. As seen on the graph, both the ADH level in plasma and the ADH pool size are subject to homeostatic regulation. If the ADH pool becomes depleted, more ADH is

Stock flow diagram of the sector is given in Figure 7.25. Brief descriptions of the variables used in this sector are presented in Appendix B.

This sector includes three stock variables, which represent the Renin, ALD, and the perceived ALD concentration (ALD_conc_perceived). A decrease in blood volume and/or blood pressure stimulates renin secretion in the kidney, and an increase in arterial pressure inhibits its release (Weir and Dzau, 1999).

The work of Guyton and Coleman (1980) suggests that an increase in MAP of as little as 5 or 10 mm Hg will halve the amount of renin hormone in the kidney, whereas a decrease of 30 mm Hg may increase its value up to 6 fold. Based on these data, the effect of MAP is defined as a graphical function, which can be seen in Figure 7.26. Ordinarily the plasma renin “activity” is measured rather than the amount of renin in the kidney, so a variable called “renin activity” is defined, which is found by division of Renin amount by the EC fluid volume. Its normal value is 1 under steady-state conditions. The time lag associated with the appearance and disappearance of renin in the bloodstream is about 15 minutes.

Once in the blood stream, renin catalyzes a chemical process which ends with the production of angiotensin II as an end product. This product is termed shortly as ANG in this study. ANG is not defined as a stock, since it is rapidly removed from the circulation with a half-life of less than one minute. Its value can be safely approximated to be a constant multiple of the renin activity.

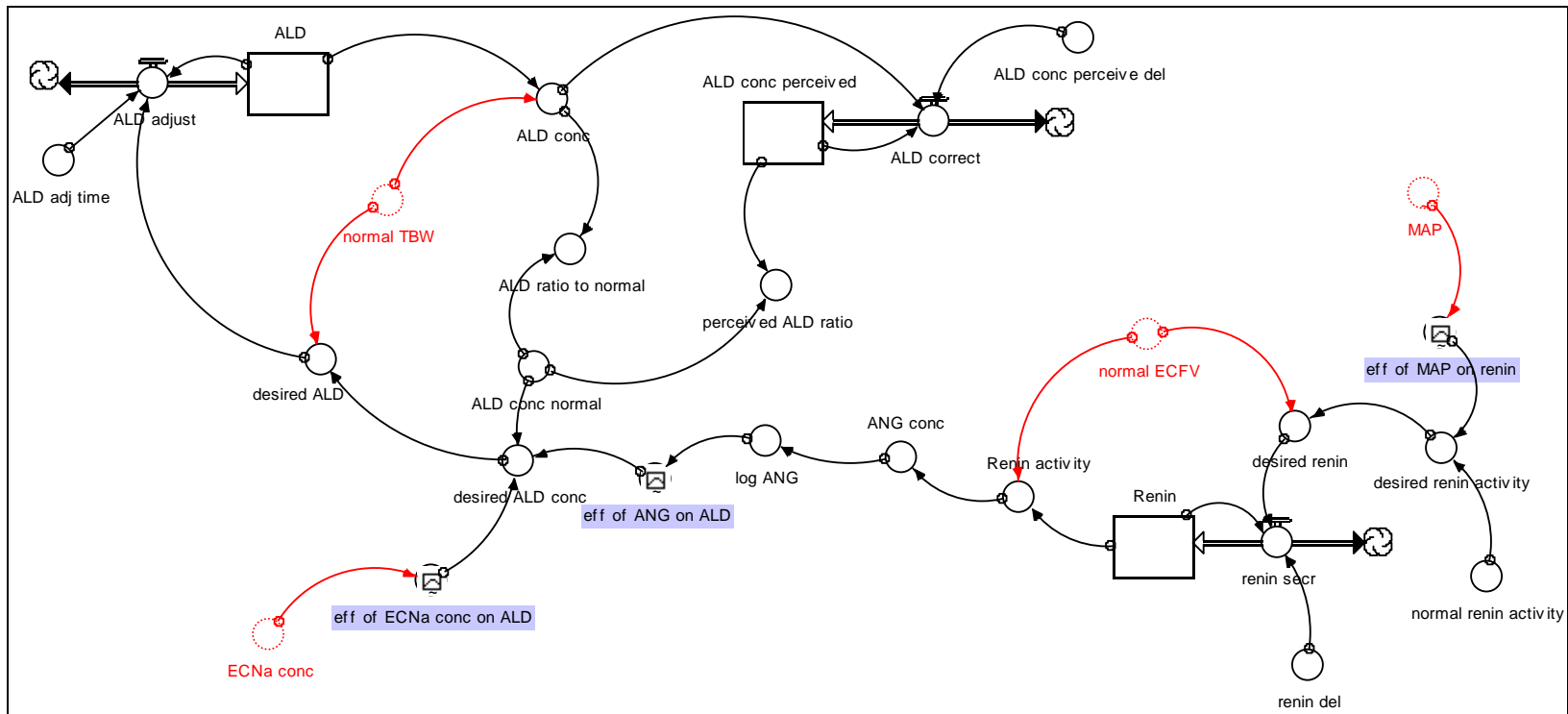

Figure 7.25. Stock-flow diagram of the RAAS

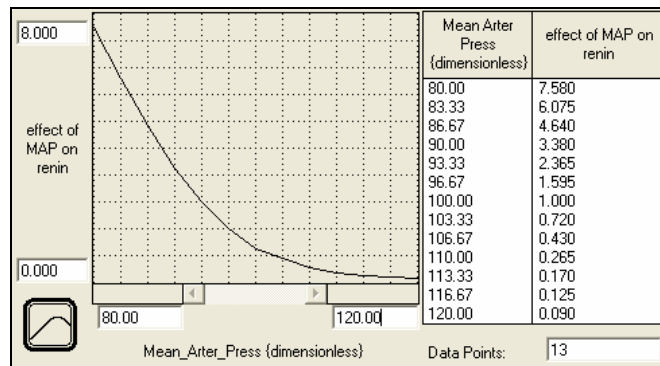

Figure 7.26. Effect of mean arterial pressure on renin secretion

As mentioned before, the Renin-ANG system is assumed to function by changing the rate of ALD secretion, i.e. the effects of ANG will appear indirectly. Secretion of ALD is principally stimulated by the ANG level, and of lesser importance are decreased Na^+ and increased K^+ concentrations in blood (Bray et al., 1989). ALD concentration is increased by a rise in ANG and/or by a fall in EC sodium. However, it is not apparent whether the increase in ALD secretion is a direct function of the decreased Na^+ ion concentration itself or is a result of some other effect associated with diminished total body sodium, since it is almost impossible to deplete the body sodium without also decreasing the EC fluid volume or without causing marked increase in renin activity. Quantitative estimations of the effect of ECNa concentration on ALD secretion are also not very satisfactory. Guyton states that a 10 to 20% fall in ECNa concentration can rarely double the ALD level. However it is known that severe hyponatremic patients have increased ALD levels despite of apparent water retention.

The effects of ANG and ECNa concentration on ALD secretion are defined via graphical functions which may be seen in Figures 7.27 and 7.28. Effect of ANG is defined by using its logarithm, since most of the actions of the RAAS hormones are logarithmic in nature (Coleman and Hall, 1992).

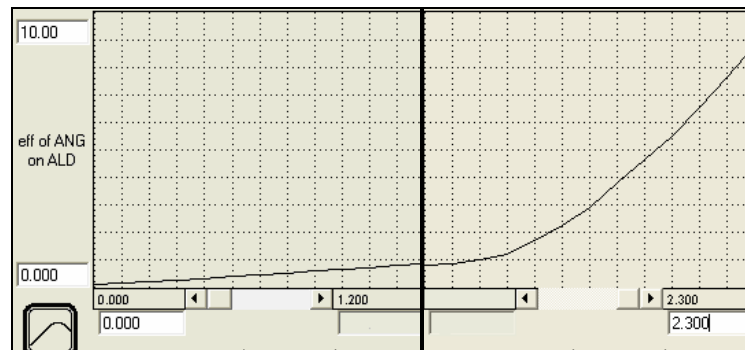

Figure 7.27. Effect of Angiotensin on Aldosterone

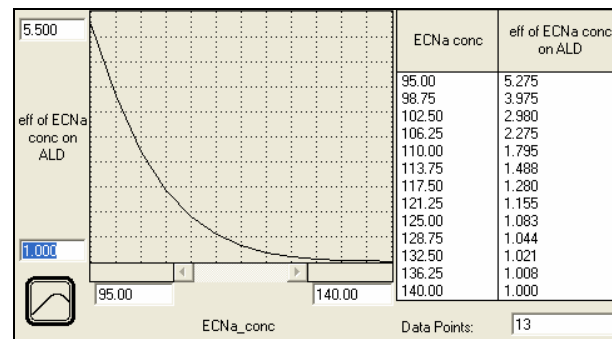

Figure 7.28. Effect of EC sodium concentration on Aldosterone

7.4.3.3. The Structure Related to the Atrial Natriuretic Hormone (ANH): Similar to the RAAS, the ANH sector mainly interacts with the body sodium and body water sectors. However ANH works to oppose the RAAS, as it produces an immediate and marked natriuresis. The structure constructed in this sector aims to simulate the ANH dynamics in response to variations in body water and body sodium.

Stock flow diagram of the sector is given in Figure 7.29. Brief descriptions of the variables used in this sector are presented in Appendix B.

The normal ANH level is given by the constant variable (`basal_ANH_conc`), and this value can be changed from its normal mainly by changes in EC fluid volume. Several studies show a close relationship between the degree of EC volume change and the ensuing ANH secretion (Yamasaki et al., 1988). Based on these studies, the effect of EC fluid on the desired ANH is defined as a graphical function, which may be seen in Figure 7.30.

The second factor that affects the ANH level is postulated to be the distribution of water between the EC and IC water, which is mainly determined by sodium ions. Therefore we postulate that ANH is affected by the distribution of water between EC and IC compartments. The effect of water distribution on ANH production is formulated with a graphical function (See Figure 7.31) using ECFV divided by ICFV. Accordingly, high sodium levels increase the ANH level from its normal, since an increase in body sodium causes also an increase in the ECF/ICF volume ratio.

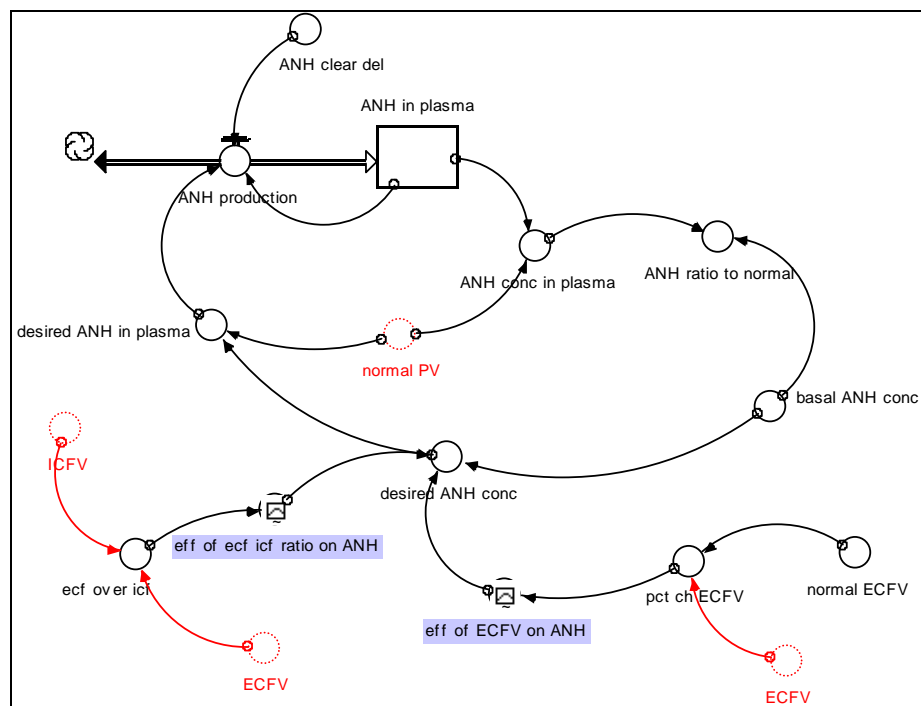

Figure 7.29. Stock-flow diagram of the ANH sector

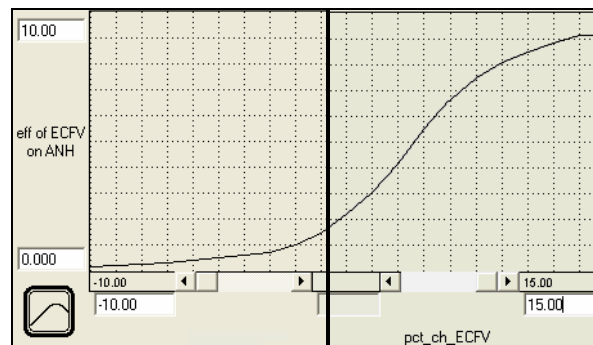

Figure 7.30. Effect of EC fluid volume on ANH

Unlike the RAAS, ANH is able to act in short-term and has an immediate effect on sodium excretion. It is observed that its effects appear soon as it is stimulated and also disappear quickly after correction of the stimulating condition, e.g. volume expansion. (Bricker, 1967).

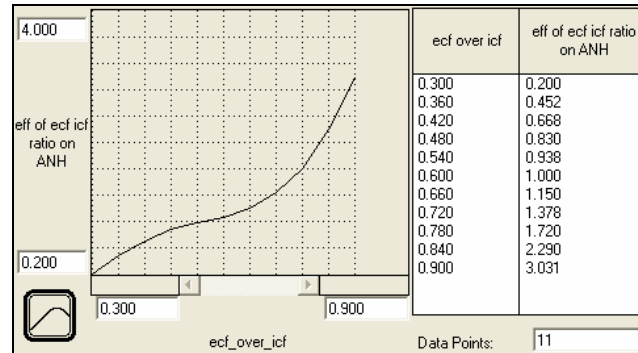

Figure 7.31. Effect of EC-IC fluid volume ratio on ANH

As mentioned before, the RAAS and the ANH principally regulate the sodium balance. However, the regulators of sodium balance inevitably affect the water balance due to various functional interrelationships between the sodium and water balance.

Figure 7.32 provides a brief causal-loop diagram that demonstrates the causal mechanisms related to these relationships. The 1st and the 2nd loops indicate the effect of ANH on water balance. If total body water increases, the level of the ANH increases due to the expansion of the EC volume. However one should keep in mind that the effect of EC volume expansion is mostly promoted by changes in sodium load than by changes in volume load per se. In the former, the infused water is distributed between the EC and IC compartments proportionally, i.e. 3:5; however in the latter case, sodium causes to shift water from IC to EC spaces until the osmolalities are equal. Even so, a rise in body water level causes an increase in ANH levels, and thus in the sodium excretion and the urine flow rates.

Similarly, the RAAS is also activated by a change in total body water levels; however the final effect is determined by a competition between two factors that affect the ALD

7.4.4. Dynamics of the Hormonal System Sectors in Isolation

As in the former case, this sector is isolated from other sectors and the behavior of the system covered by this sector is studied. For this purpose, dynamics of two hormone systems, i.e. the ADH and the RAAS, are studied separately.

The ADH sector is simulated by two different input forcings. In the first experiment, the ECNa concentration is suddenly increased from 142 to 143 mEq/L, i.e. the EC osmolality is increased by 0,7 percent (See Figures 7.33 and 7.34). Plasma ADH level promptly responds to this small increase, and reaches a new steady-state level in half an hour. Accordingly, its inflow and outflow, i.e. the actual ADH release rate and the ADH clearance rate approach to each other and become equal in the steady-state.

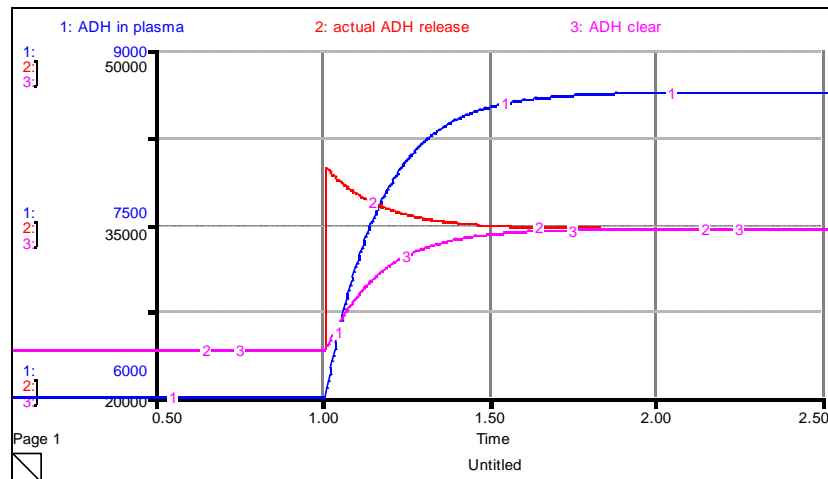

Figure 7.33. ADH in plasma and related flows in isolated sector run with increasing ECNa concentration

On the other hand, the ADH pool is gradually depleted, and thus the ADH production rate increases to replenish the pool and to reach another, albeit lower, steady-state value for the ADH pool. Since the ADH pool size is fairly greater than the required amount, the decrease in the pool size might be considered as unimportant, and it can be concluded that the adaptive mechanism of the ADH system works fine.

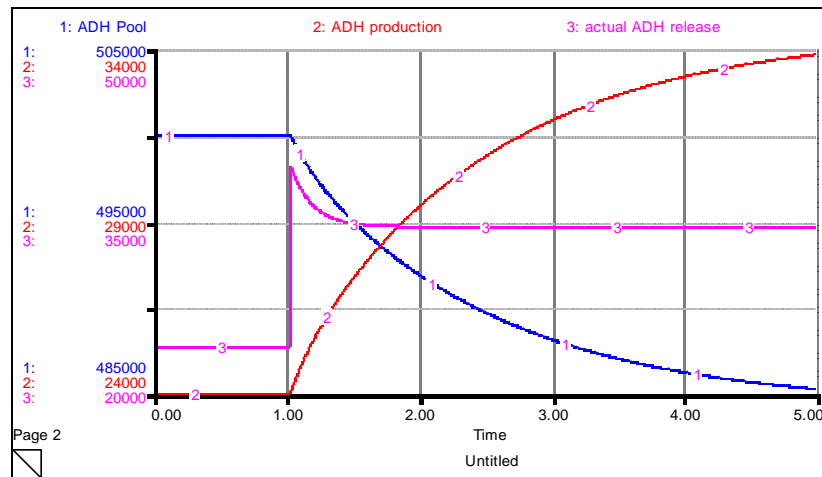

Figure 7.34. ADH Pool level and related flows in isolated sector run with increasing ECNa concentration

In the second experiment, the input forcing is greater than the first one, and also the ADH secretion capacity is reduced on purpose (See Figures 7.35 and 7.36). The ECNa concentration is linearly increased from 142 to 145 mEq/L in 10 hours and then stays constant, and the secretion capacity is reduced by 80%, like in the case of Diabetes Insipidus, which is mentioned in Section 2.2.1 in more detail. It is seen that the ADH pool is seriously depleted and reaches a new lower steady-state value, despite increasing ADH production. The ADH level in plasma also first increases to its desired level, but then it cannot sustain at this level and reaches a lower steady-state value. The graph in Figure 7.36 depicts that deficiency more clearly. As the ADH pool becomes gradually depleted, the ADH availability also decreases, and actual ADH release rate starts to lag behind the desired ADH release rate that is dictated by the plasma ECNa concentration.

The isolated RAAS is simulated in two different settings. In the first case, the mean arterial pressure is decreased from its normal value of 100 mmHg to 95 mmHg (See Figure 7.37). Renin level responds to this stimulus by increasing from its normal value, and it reaches a new and higher steady-state level, as expected.

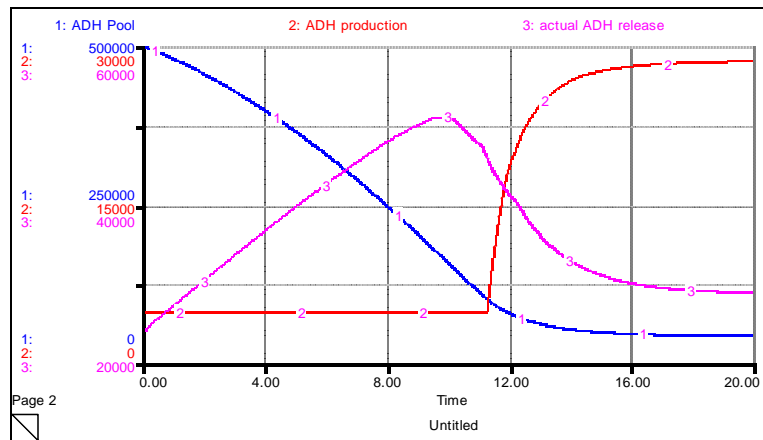

Figure 7.35. ADH Pool and related flows in isolated sector run with an increasing ECNa concentration and an 80% decrease in secretion capacity

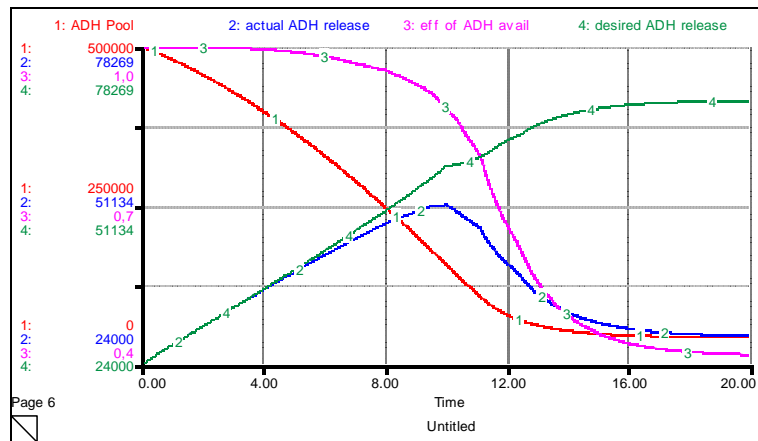

Figure 7.36. Actual ADH release and its determinants in isolated sector run with an increasing ECNa concentration and an 80% decrease in secretion capacity.

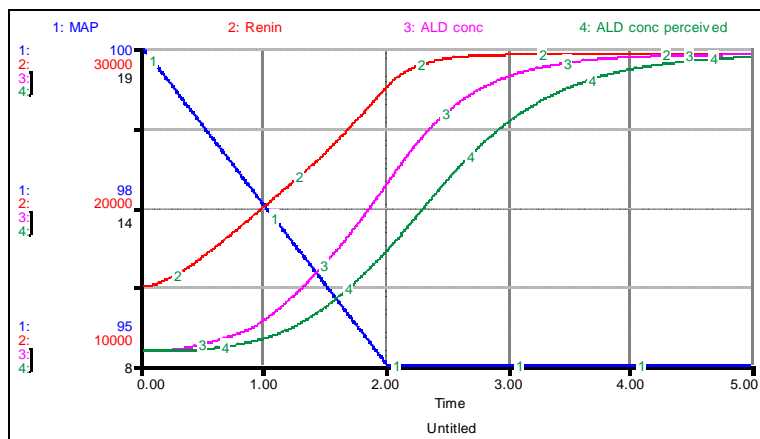

Figure 7.37. Renin, ALD and Perceived ALD stocks in isolated sector run with a decrease in MAP

In the second experiment, the mean arterial pressure (MAP) is increased from its normal value of 100 mmHg to 105 mmHg in 2 hours. Simultaneously, the ECNa concentration is decreased from its normal of 142 mEq/L to 120 mEq/L in 3 hours. The graph in Figure 7.38 depicts that the intensity of these competing effects determine the final level of ALD. Increasing levels of MAP first cause a decrease in ALD levels, however if the sodium levels of the body become very low and constitute a more important threat than the increase in arterial pressure, ALD may change direction in order to preserve the body sodium.

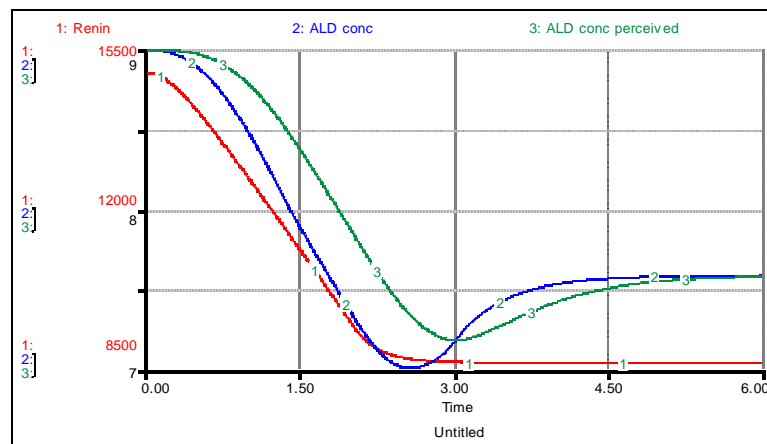

Figure 7.38. Renin, ALD and Perceived ALD stocks in isolated sector run with an increasing MAP and mildly decrease in ECNa concentration

7.5. Urinary Sodium Concentration Sector

7.5.1. Background Information

Human beings share a common problem with the other mammals that live on land, i.e. conservation of water and elimination of body wastes in a nontoxic and concentrated form. This is an absolute necessity for the relative constancy of our internal environment since water is continuously lost from the body. Moreover, forming a small and concentrated urine will minimize the required fluid intake to match this continuous loss, a feature that is especially important when water is restricted for some reason. Therefore, the ability of the

kidney to produce a highly variable urine is essential for our survival (Strand, 1983; Guyton, 2000).

The kidney senses even the very minute changes in the concentration of blood constituents, and then it continuously adjusts the amounts of these substances to be returned to the blood and to be removed in the urine. According to the hydration level of the body, the kidney can both use its antidiuretic mechanisms, or its diuretic mechanisms. When there is excess water, a dilute, watery urine is formed; otherwise the urine will be concentrated to compensate the loss of water.

The capability to dilute or concentrate urine appropriately depends on various factors; however, under normal physiological conditions, the ADH level is the main determinant of urine osmolality. As explained in Section 7.4.3, ADH influences the rate of water excretion by promoting concentration of urine. The way how ADH affects urine concentration and urine flow will be explained in Sections 7.5.3 and 7.2.3 in more detail.

On the other hand, there is a combination of factors other than ADH which are acting in the absence and/or presence of ADH and change the urinary concentration accordingly, which is another indicator for the complexity and importance of the urinary concentrating phenomenon:

GFR is one of the most important factors affecting urinary osmolality. It can influence the final osmolality of urine directly by varying the rate of fluid delivered to collecting ducts. Indeed, anything that reduces fluid delivery to the collecting ducts, e.g. a diminished GFR or a diminished number of nephrons, impairs urinary dilution. The importance of this ability is revealed when the organism is deprived of water, since free water clearance can be completely abolished in some circumstances, even in the absence of ADH (Jamison, 1982). On the contrary, anything that increases the rate of fluid delivered to collecting ducts will dilute the urine, e.g. an increased GFR induced by sustained expansion of EC fluid volume can result in a hypo-osmotic urine, even when high levels of ADH are present.

Persistent severe hypokalemia (low levels of plasma K^+ concentration) is another factor that leads to an impairment of the urinary concentrating ability. The required potassium deficit is generally above 200 mEq, while the total K^+ stores of the body are in the order of 3500 mEq (Wong and Verbalis, 2002). At twice this deficit, maximal urinary osmolality that can be attained approaches that of plasma, and further deficits will have no additional effects. However under normal conditions, the total K^+ stores of the body are protected very tightly by the kidney and other hormonal factors, i.e. ALD.

Furthermore, there are some internal mechanisms that can affect the urinary concentration in some disease states. The “ADH escape” phenomenon mentioned in Section 2.2.2 represents one of the adaptive mechanisms of the body that is used to limit excessive water retention in SIADH by diminishing the antidiuretic efficacy of ADH.

7.5.2. Fundamental Approach and Assumptions

Regulation of urine concentration is a complex phenomenon that depends on various factors, which are explained in the previous section in detail. Among these, only the most important factors, i.e. ADH and GFR are included in the model. Furthermore, the effect of “ADH escape” as a defense mechanism of the body against excessive water retention is also included due to its close association with the SIADH.

One of the most important assumptions of this sector is the exclusion of urea from the urinary concentration calculation. As a result, sodium chloride is assumed to be the only contributor to the urinary concentration. In reality, urea also contributes about 40 percent of the urine osmolality (Guyton, 2000) and there are also some other electrolytes which contribute to urine osmolality in rather small amounts. Since urea is not included in the model, urine osmolality is considered to be the same as the urine sodium concentration.

It should be noted that under normal physiological conditions, ADH will be the only determinant of urine concentration in reality and also in the model. Effects of GFR and sodium excretion rate appear to be potent under extreme conditions such as water

deprivation, high solute excretion or when endogenous ADH is inappropriately regulated for some reason. Similarly, the adaptive response of ADH-escape only appears in the presence of a danger, i.e. severe water intoxication/hyponatremia.

It is assumed that the only effect of plasma ADH level is on urine osmolality and thereby on urine flow rate. That means ADH only acts on water excretion, and the Na⁺ excretion is unaffected by ADH. However ADH has also some well-known vasoconstrictive effects at high doses which are omitted in this study. Furthermore, some studies mention the effect of ADH on sodium reabsorption at higher concentrations (Bankir, 2001), but to date no reliable data is available about the possible effect of ADH on sodium reabsorption.

7.5.3. Description of the Structure

Urinary sodium concentration sector is a calculation sector responsible for finding the final value of the urine sodium concentration (UNa_conc). This sector mainly interacts with the ADH, body water and sodium sectors and its output determines the water excretion rate to a considerable extent.

Stock flow diagram of the sector is given in Figure 7.39. Variables used in this sector are presented in Appendix B with their brief descriptions and units.

As mentioned before, ADH is the main determinant of the urine osmolality. The effect of ADH on UNa_conc is formulated with a graphical function (See Figure 7.40) using the ADH_ratio_to_normal, i.e. the instant plasma ADH concentration divided by its reference value. The UNa concentration implied by ADH (implied_UNa_conc_by_ADH) is formulated by dividing the normal UNa concentration by the effect of ADH:

$$\text{implied_UNa_conc_by_ADH} = \frac{\text{normal_UNa_conc}}{\text{eff_of_ADH}} \quad (7.14)$$

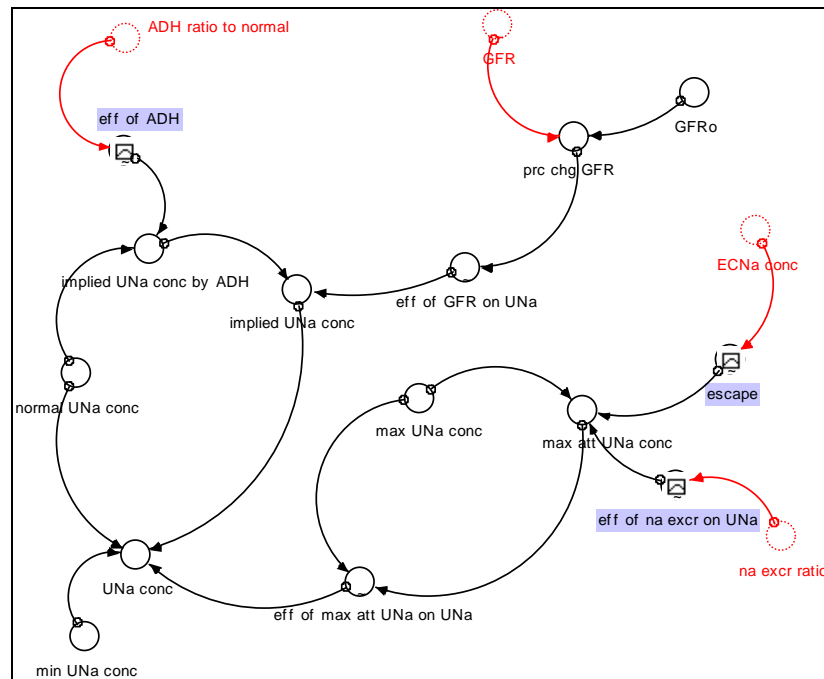

Figure 7.39. Stock-flow diagram of the urinary sodium concentration sector



Figure 7.40. Effect of ADH concentration on UNa concentration

The above graph depicts that, as ADH increases, its antidiuretic effect and thereby the urine osmolality increases, but only up to a point, which is the limit set by the maximal concentrating ability of the kidney. For young adults, the upper limit to the maximal concentration of urine is about three-four times the osmolality of plasma (Janicic and Verbalis, 2003). Accordingly, from the graph it can be seen that the renal response to circulating ADH saturates when ADH concentration reaches approximately 3 times of its normal level, after which urinary osmolality is maximal and cannot increase further despite additional increases in ADH levels. With maximal concentrations of ADH (maximal

antidiuresis), as little as 0,4-0,5 l. of urine may be excreted per day (about 0,3 ml/min) with a urine osmolality of about 1200 mEq/L. (Bray et al., 1989).

On the other hand, the lower limit to the minimum concentration of urine has similarly a natural limit. The water permeability of the kidney is clearly finite rather than zero, and this sets a natural limit for the maximum amount of urine that may be excreted, i.e., for the minimum level for the urinary concentration. Depending on circumstances, the sodium concentration in urine may fall as low as 10-15 mEq/L (Bray et al., 1989), so the minimum UNa concentration (min_UNa_conc) is selected as 10 mEq/L. From the graph in Figure 7.40 it can be seen that even when ADH is totally absent, the maximum amount of urine that may be excreted does not increase indefinitely. Related literature suggests that severe deficiencies in ADH secretion or action may increase the basal urine output to a maximum of 10 to 15 ml/min (the normal value is 1 ml/min), which means more than 20 liters of urine per day (Kasper et al., 2004).

The second most important determinant of the urine osmolality is the GFR. As mentioned before, an increase in GFR dilutes the urine, while a decrease will concentrate it. It is reported that a decline of 8% in GFR was associated with a urine osmolality increase from 125 to 309 mEq /L (Jamison et al., 1982). Similarly, it is demonstrated that animals lacking ADH can increase their urine osmolality approximately threefold. Based on these data, the effect of the GFR on UNa concentration is defined via graphical function, which can be seen in Figure 7.41.

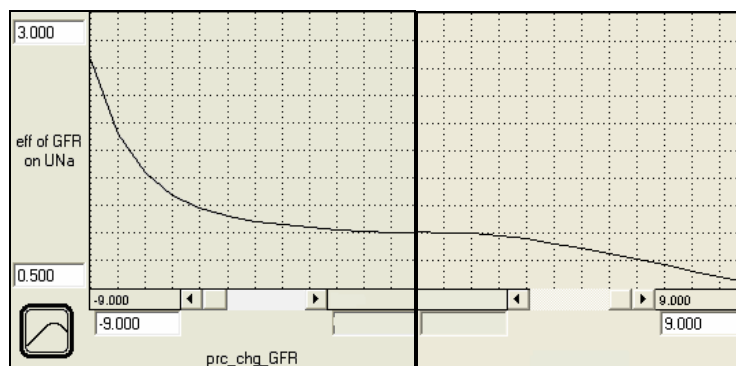

Figure 7.41. Effect of GFR on UNa concentration

The UNa concentration implied by ADH and GFR (*implied_UNa_conc*) is calculated by the following effect formulation:

$$\text{implied_UNa_conc} = \text{implied_UNa_conc_by_ADH} \times \text{eff_of_GFR_on_UNa} \quad (7.15)$$

This formulation assumes that the kidney is fully able to maximally concentrate or dilute the urine according to the requirements. However there are some other factors that limit the urinary concentration and dilution mechanism. As mentioned before, urinary osmolality approaches to isotonicity when the ability of the kidney to modify the final osmolality of urine becomes blunted. Accordingly, the maximum attainable UNa concentration by the kidney is defined by a variable (*max_att_UNa_conc*), which is affected by the escape mechanism. The escape phenomenon is limited to cases where body ADH levels are greater than normal, as in the SIADH.

$$\text{escape} = \text{IF}(\text{ADH_ratio_to_normal} > 1) \text{THEN}(\text{potential_escape}) \text{ELSE}(1) \quad (7.16)$$

$$\text{max_att_UNa_conc} = \text{max_UNa_conc} \times \text{escape} \quad (7.17)$$

The escape effect is defined via graphical function, which can be seen in Figure 7.42.

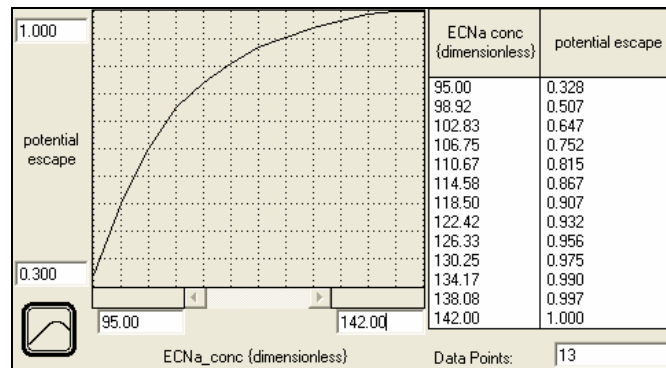

Figure 7.42. Effect of EC sodium concentration on escape from ADH

It is obvious that the maximum attainable urinary concentration will change the urine concentration implied by ADH and GFR. The effect of the max_att_UNa_conc is formulated with a graphical function (See Figure 7.43) using the max_att_UNa_conc divided by the maximum UNa concentration (max_UNa_conc) of the kidney. Finally, the final UNa_conc is calculated by using the equation below:

$$\text{UNa_conc} = \text{MIN}(\text{MAX}(\text{min_UNa_conc}, (\text{normal_UNa_conc} \times \text{eff_of_max_att_UNa_on_UNa} + \text{implied_UNa_conc} \times (1 - \text{eff_of_max_att_UNa_on_UNa}))), \text{max_UNa_conc}) \quad (7.18)$$

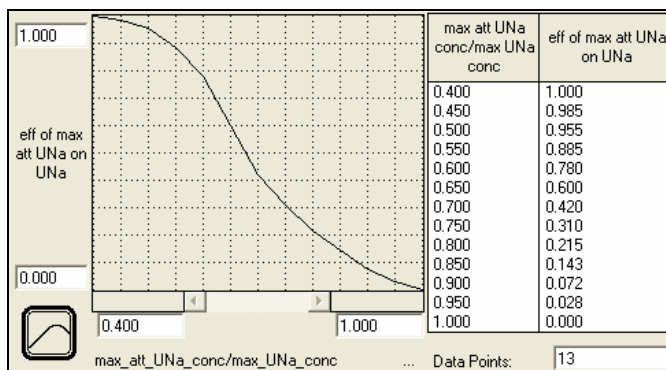

Figure 7.43. Effect of maximum attainable UNa concentration on UNa concentration

According to this equation, UNa_conc approaches to the isotonicity, i.e. to the normal_UNa_conc of 125 mEq/L, when effect of max_att_UNa_conc increases. A lower and an upper limit for the urine concentration are still applied to prevent unrealistic levels of UNa_conc. The use of a minimum value for the UNa concentration implies that neither drugs nor any other effect can increase the urine flow rate above a certain maximum value.

8. VALIDATION AND ANALYSIS OF THE MODEL

The aim of this chapter is to demonstrate and analyze the results of the simulations conducted in order to test the validity of the model described in the previous chapter. The model is simulated via Stella software, and the simulation time unit is hours. A sufficiently small time step (1/32) is used for the simulation. Since some of the system behavior is evident only in the long run, time horizon of the model is set as high as 500 hours, when necessary.

8.1. Basic Dynamics of the Model

In this section the basic dynamics of the simulation model are outlined. As can be seen from the Figures 8.1 and 8.2, the continuous version of the model shows a steady state behavior when all its levels are initialized at their equilibrium values.

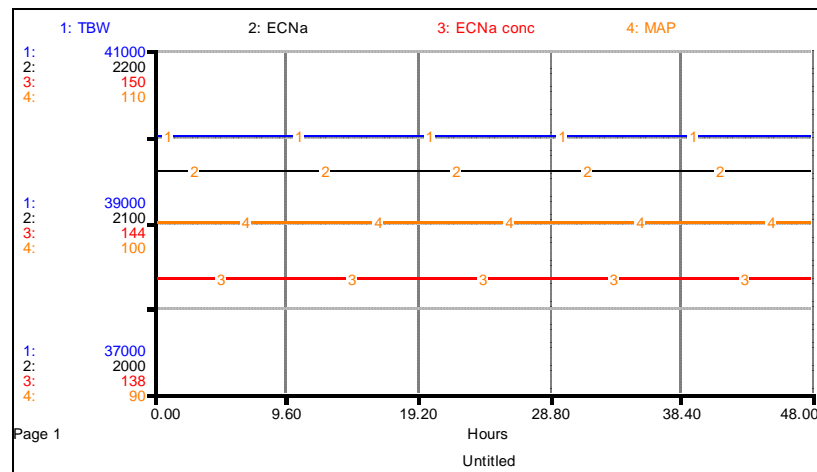

Figure 8.1. Dynamics of key variables in the base run

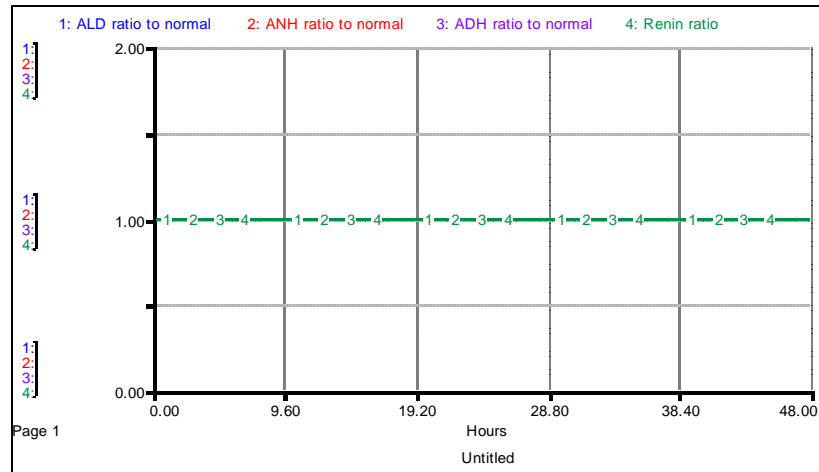

Figure 8.2. Dynamics of hormonal variables in the base run

The discontinuous drinking version of the model is simulated to demonstrate the normal daily variations in the key variables of the model (See Figures 8.3, 8.4 and 8.5). It can be seen that the ECNa and the MAP show almost no change during the day. The ECNa concentration varies between 141 mEq/L and 143 mEq/L, which is a small variation. The main change can be seen in the dynamics of the urine flow, drinking, and the UNa concentration, since water is continuously lost and then replenished by drinking. As a result, the TBW is maintained within the normal limits. The graph in Figure 8.5 demonstrates the dynamics of basic hormones, and it can be seen that ADH is the most variable hormone under normal conditions. The variation in ADH prevents higher fluctuations in the ECNa concentration in the case of varying fluid intake. On the other hand, ALD show almost no variation, since it is responsible for the long term dynamics for EC volume and sodium control. The ANH shows a medium fluctuation during the day, since it is responsible also for the short term regulation of the EC volume and sodium dynamics.

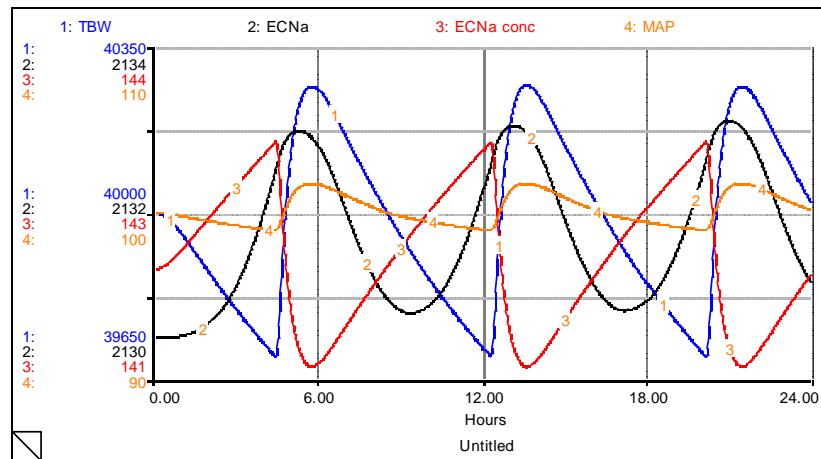

Figure 8.3. Equilibria of the key variables with discontinuous drinking

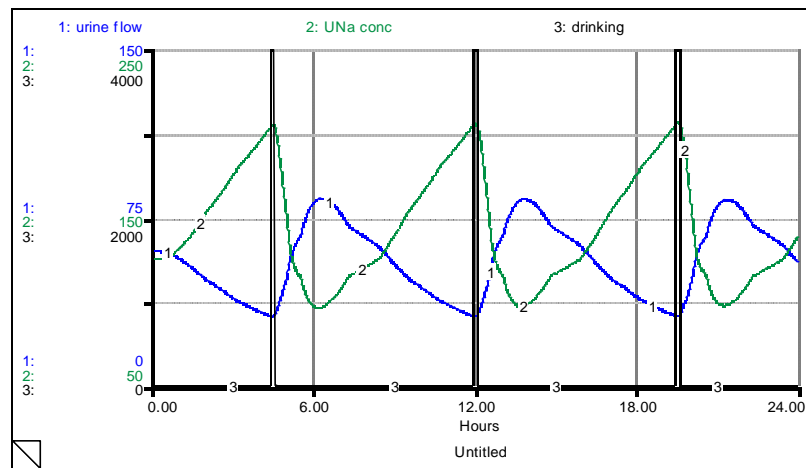

Figure 8.4. Equilibria of drinking and urinary excretion with discontinuous drinking

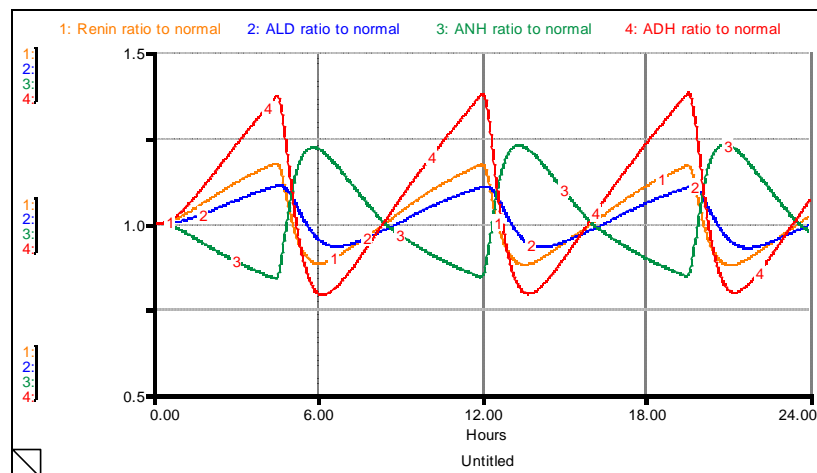

Figure 8.5. Equilibria of hormonal dynamics with discontinuous drinking

The dynamics of body fluids after water loading constitutes one of the fundamental tests of the interaction between body fluids and the kidney. Hence the urinary excretion dynamics of the model are compared with the experimental data. For this simulation, the normal_drinking variable is set to 0, and a pulse of water input of 1000 ml is given at time 0. The urine flow rate increases about 11 fold in one hour, and after 3 hours it returns to its normal value, as expected (See Figures 8.6 and 8.7). On the contrary, urine concentration decreases, causing excretion of large volumes of dilute urine (See Figure 8.8). On the other hand, the sodium excretion remains relatively constant during this times interval, when compared to the urine flow.

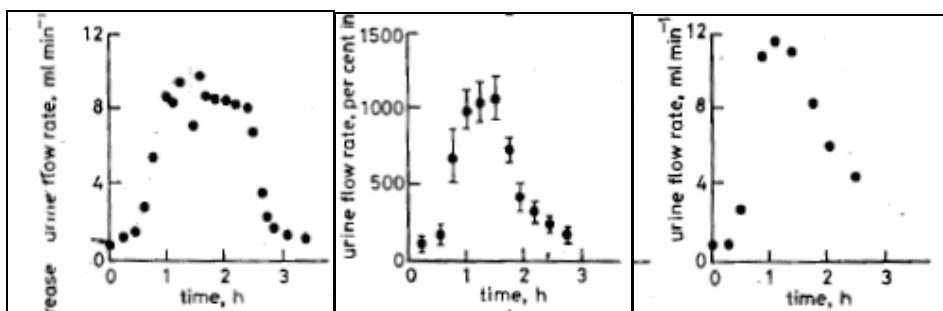

Figure 8.6. Urine flow following ingestion of 1 L of water; (a) data from Baldes and Smirk, (1934), (b) data for eight subjects (mean \pm std. error), (c) data for one subject - from (Uttamsingh, 1985)

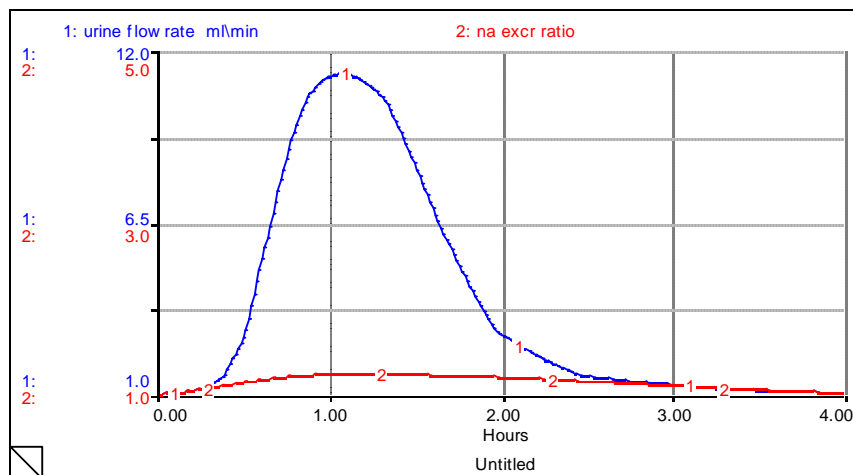

Figure 8.7. Base dynamics of urinary excretion following ingestion of 1 L of water

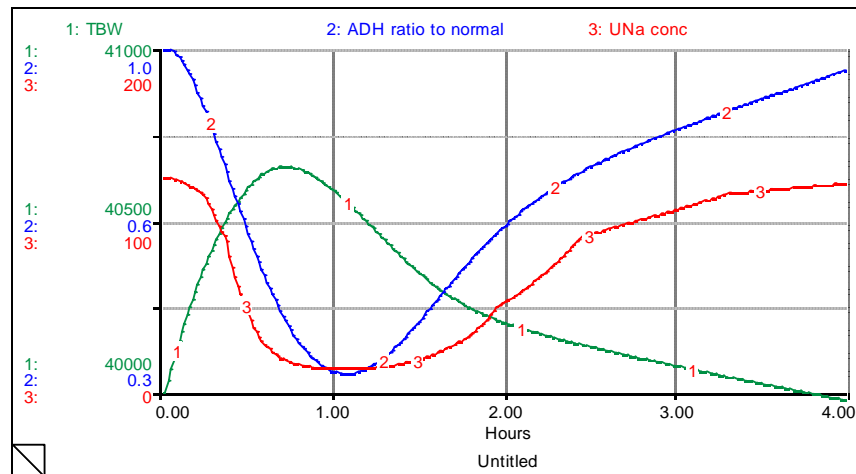

Figure 8.8. Base dynamics of body water following ingestion of 1 L of water (TBW in ml)

Body sodium dynamics following water ingestion is given in Figure 8.9. The ECNa decreases only 4 mEq/L, since sodium excretion increases only about 20%, after which it starts to decrease. The increase in sodium excretion can be attributed mainly to the ANH hormone, since EC volume expansion after water loading causes a rise in the ANH. These responses prevent the ECNa concentration to decrease markedly during excess water ingestion (Guyton, 2000). In this simulation, the ECNa concentration fell only about 2 mEq/L.

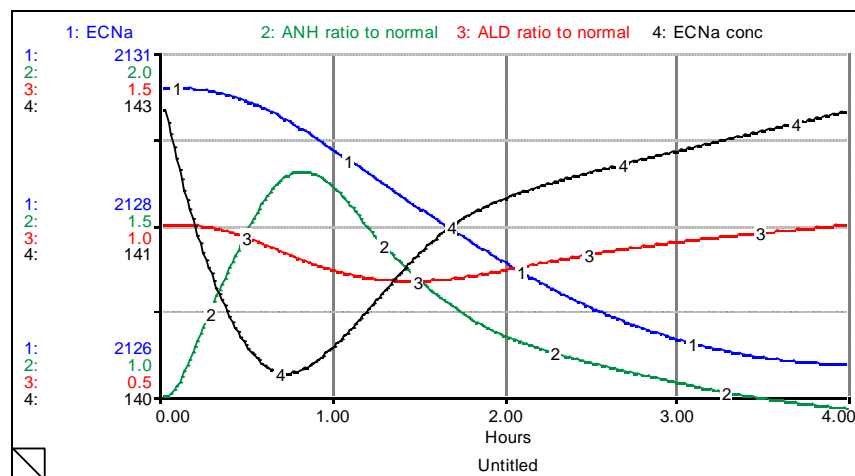

Figure 8.9. Base dynamics of body sodium following ingestion of 1 L of water

Above simulations demonstrate that the kidneys continuously play with the concentration of urine via the ADH under normal conditions. Figure 8.10 gives a schematic representation of the normal physiologic relationships among EC_{Osm} , AVP (or ADH) concentrations, U_{Osm} , and urine volume. Accordingly, urine osmolality is proportional to plasma ADH levels, but urine volume is inversely related to urine osmolality.

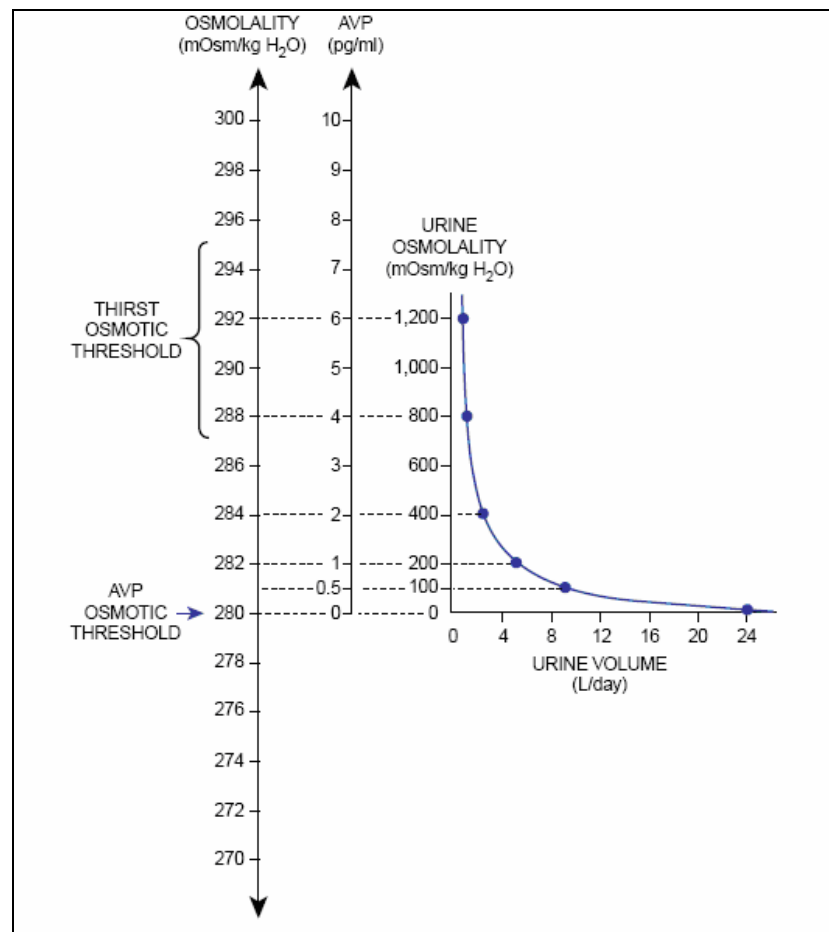

Figure 8.10. Normal physiologic relationships among EC osmolality, ADH concentration (AVP axis), urine osmolality, and urine volume in man (from Verbalis, 2003)

The model simulated results for the relationship between the urine flow and the UNa concentration in the base run and the water loading tests are given in Figure 8.11.

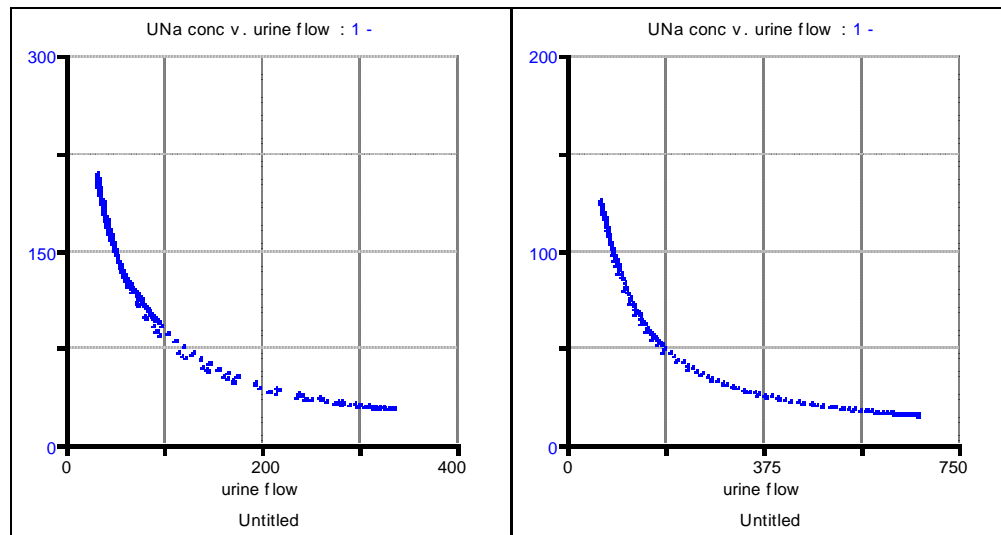

Figure 8.11. Simulated relationships among urine flow and UNa concentration (a) for the base run, (b) after ingestion of 1 L of water

8.2. Validation of the Model

This section focuses on the analysis of the model structure and behavior in order to see whether they yield valid behavior patterns for corresponding values of model parameters. Validation of system dynamics models mainly concentrates on the internal structure of the model, and behavior validation is tested only after there is enough confidence in the underlying structure. Hence, a formal validation process is followed in order to detect structural flaws of the model (Barlas, 1996).

As mentioned in the methodology section, validation is actually integrated to the model building process, rather than being a separate stage after model building. Many direct structure tests are performed during the model building process, and a selected sample of the isolated sector runs are presented in the model description. The validation of the model is basically demonstrated by performing “structure-oriented behavior tests” proposed in literature, such as extreme condition and behavior sensitivity tests. The model behavior is also compared with the real data, where data are available.

8.2.1. Experiments with Changes in Daily Water Intake

8.2.1.1. Increased Daily Water Intake: The daily water intake is increased from 2,2 L. to 4,4 L. by changing the normal_drinking variable and resetting the thirst feedback on drinking. There is almost no change in the TBW, MAP, and the ECNa, as expected. The ECNa concentration slightly fell to 141 mEq/L from 142 mEq/L due to the small decrease in the ECNa (See Figure 8.12). The main effect of an elevated water intake is a great fall in the UNa concentration and a consequent rise in the urine flow. From the graph in the Figure 8.13 it can be seen that the UNa concentration fell from its normal value of 125 mEq/L to 48 mEq/L, and the urine flow is increased from its normal value of 60 ml/h to 155 ml/h.

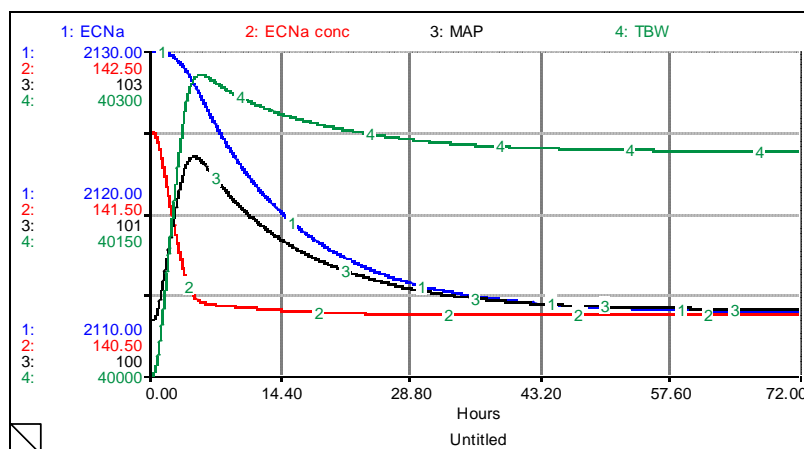

Figure 8.12. Dynamics of key variables in case of increased daily water intake - flows and volumes are in ml

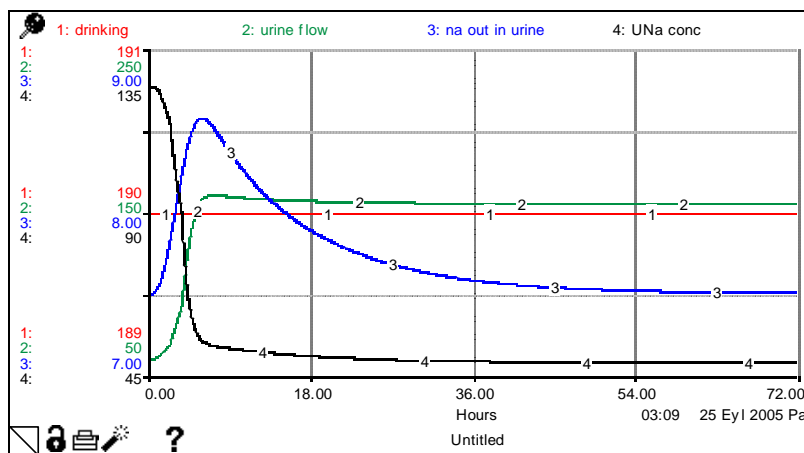

Figure 8.13. Dynamics of key variables in case of increased daily water intake - cont.

8.2.1.2. Decreased Water Intake: The daily water intake is decreased from 2,2 L to 1,75 L. As in the first case, the main change is a decreased water turnover, i.e. the urine flow is decreased almost 20% via an increased UNa concentration. The transient fall in the sodium excretion causes a small rise in the ECNa concentration, as expected.

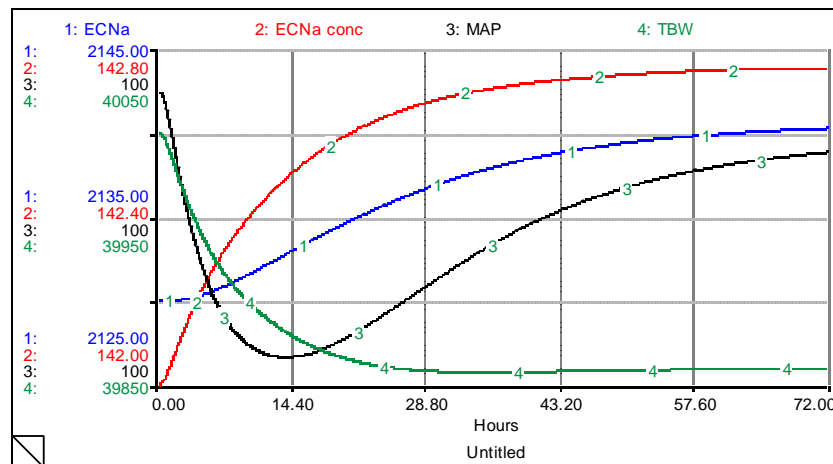

Figure 8.14. Dynamics of key variables in case of decreased daily water intake - flows and volumes are in ml

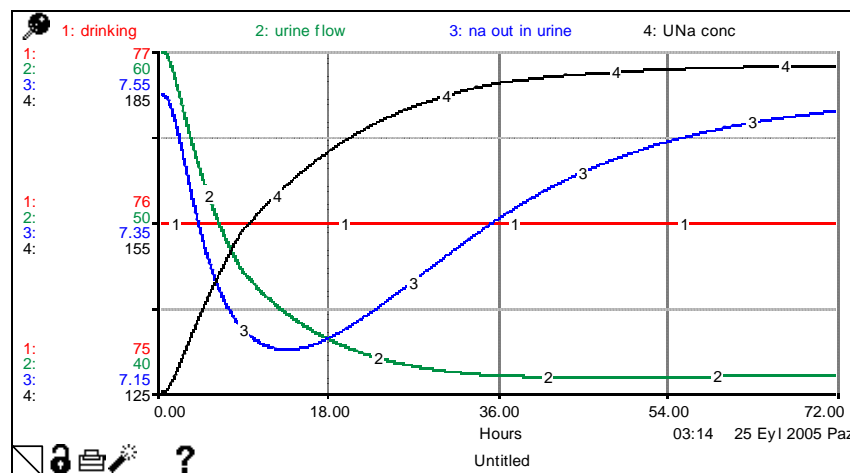

Figure 8.15. Dynamics of key variables in case of decreased daily water intake - cont.

8.2.1.3. Sensitivity of Blood Volume to Different Levels of Daily Water Intake: Under normal conditions, blood pressure (or blood volume) is not affected by changes in fluid

intake (Guyton, 2000). Figure 8.16 demonstrates the fact that the blood volume remains almost constant despite extreme changes in fluid intake.

This condition is simulated by varying the daily water intake (normal_drinking) of the person from its normal value, which is about 2,2 liters in this simulation (See Figure 8.17). As in the real case, the blood volume stayed almost constant when the daily water intake is changed from its normal.

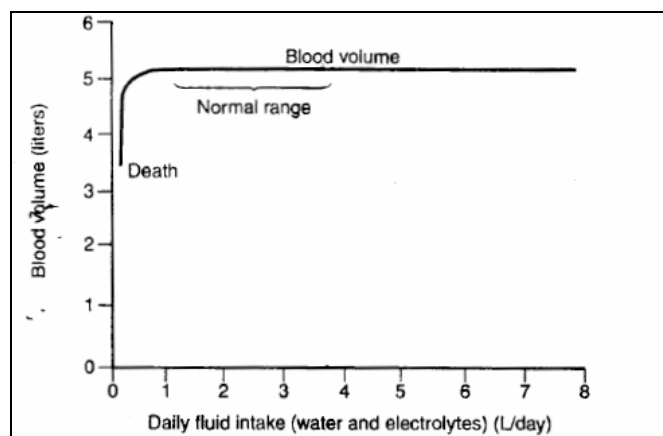

Figure 8.16. Approximate effect of changes in daily fluid intake on blood volume (from Guyton, 2000).

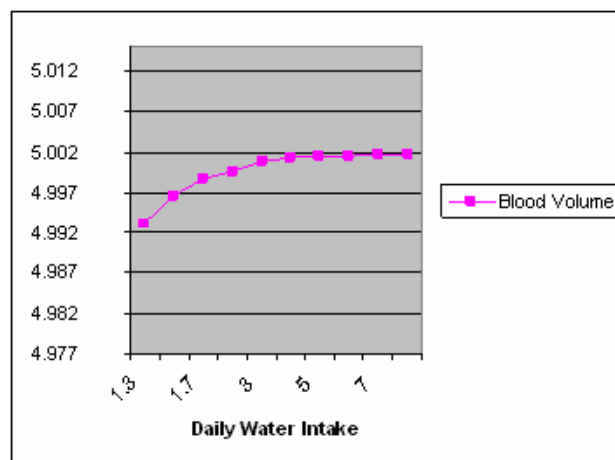

Figure 8.17. Simulated effect of changes in daily fluid intake on blood volume (in liters)

However, the variability of urine volume also has its limits. If the daily water intake always stays below the minimum water output (insensible losses and the obligatory urine flow), then the fluid balance cannot be preserved, and this leads to death after several days, as expected. The model demonstrates that there is a minimum necessary amount of water, which is about 1,2 liters in this simulation. Figure 8.18 demonstrates a case in which the daily water intake is 500 ml. Even if the urine flow is minimized by concentrating the urine maximally (UNa_conc), the amount of water intake (drinking) stays apparently below the amount of loss (water_lost). Consequently, it can be said that blood volume and mean arterial pressure are not affected by changes in fluid intake, as long as the fluid intake and the fluid loss are precisely balanced.

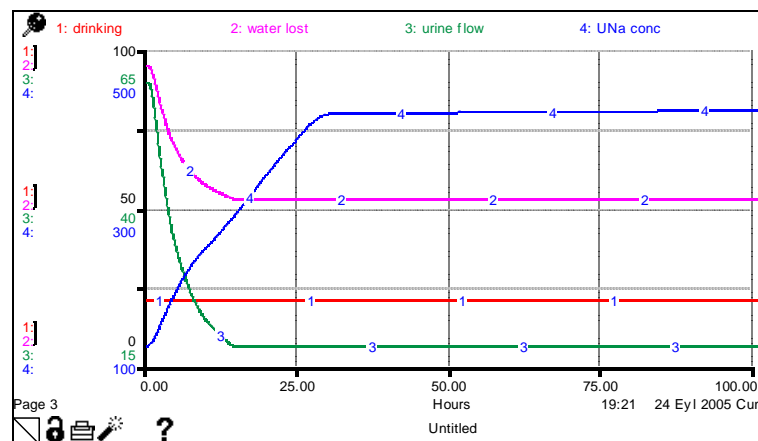

Figure 8.18. Model behavior for excessively low water intake

8.2.2. Experiments with Changes in Daily Sodium Intake

8.2.2.1. Increased Daily Sodium Intake: In this simulation, the daily sodium intake is slightly elevated from 180mEq per day (the equilibrium value) to 235 mEq per day. The steady state levels of the ECNa concentration, the MAP, the TBW and the ECNa are slightly higher than normal, as expected (See Figure 8.19). This can be explained as follows: Increased salt intake causes an increase in the ECNa concentration, which stimulates thirst and increases drinking. This increases the body water and leads to the subsequent effects of volume on arterial pressure.

On the other hand, urine flow is first decreased due to increased ECNa concentration, but then it increases to match the elevated water intake (See Figure 8.20). The resulting urine is slightly concentrated than normal, as expected.

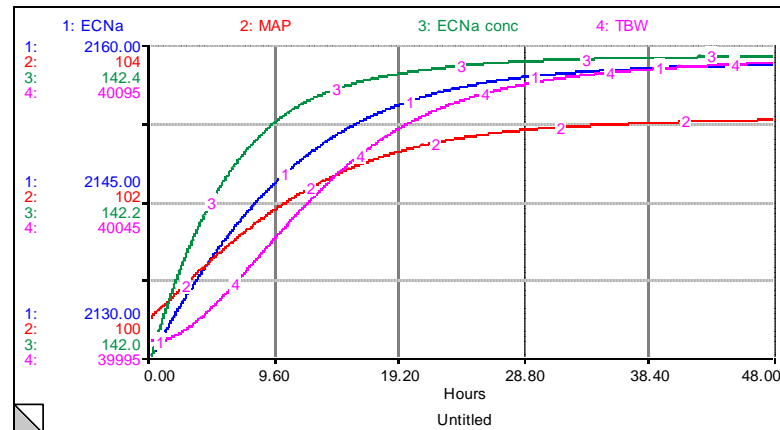

Figure 8.19. Dynamics of key variables in case of increased sodium intake

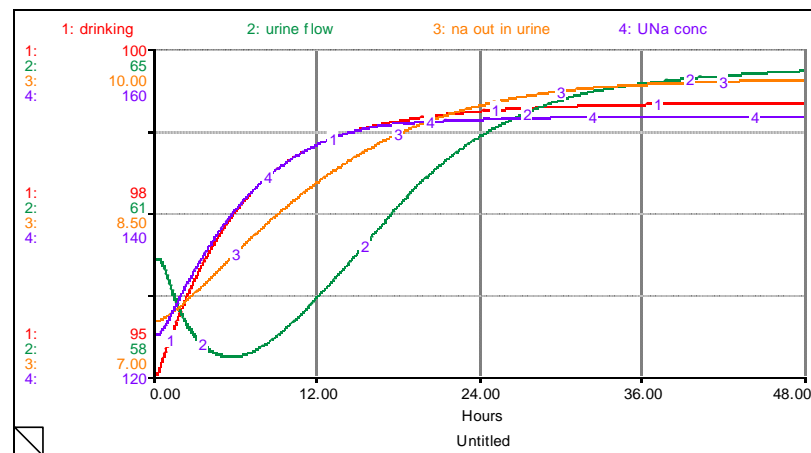

Figure 8.20. Dynamics of key variables in case of increased sodium intake – cont.

8.2.2.2. Extreme Sodium Intake: In this experiment, the daily sodium intake is increased by fourfold. The results demonstrate that changes in sodium intake have little effect on the ECNa concentration and the total body water, but they have a great effect on the MAP. In this simulation, the MAP is increased by 12%, whereas the change in the ECNa concentration and the TBW remain between 1-2%. The underlying reason for the increase in MAP is the shift of water between the EC and the IC compartments (See Figure 8.23).

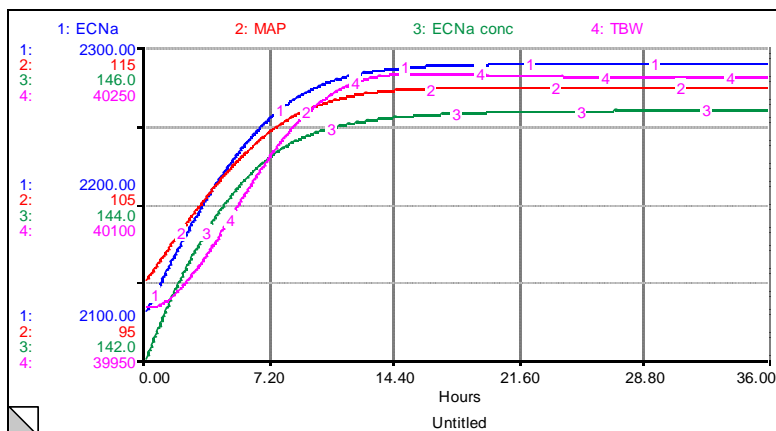

Figure 8.21. Dynamics of key variables in case of extreme sodium intake

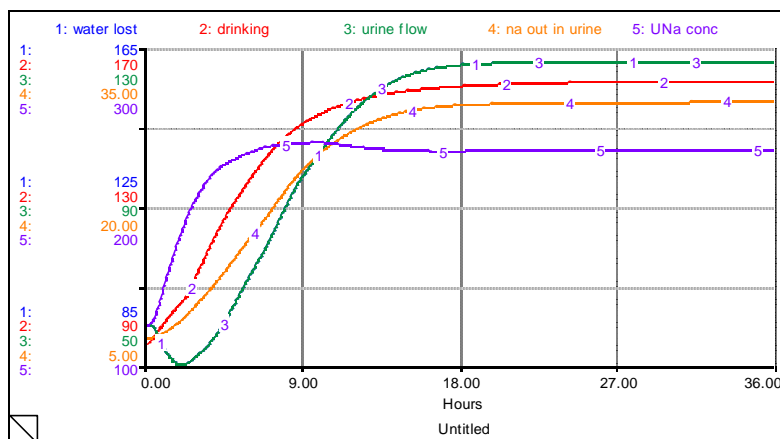

Figure 8.22. Dynamics of key variables in case of extreme sodium intake – cont.

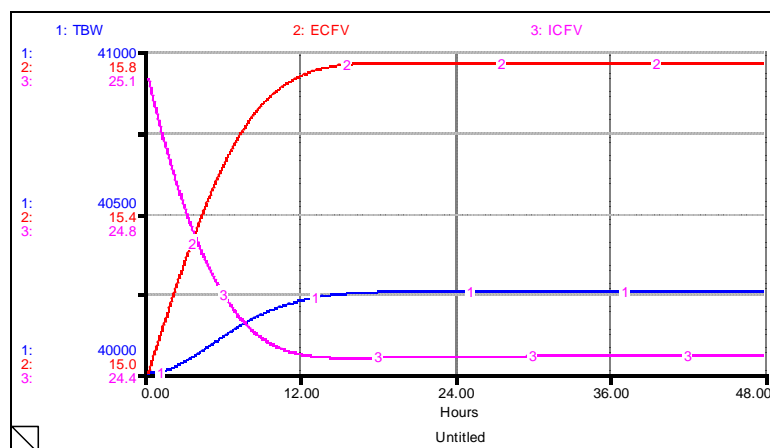

Figure 8.23. Dynamics of body water compartments in case of extreme sodium intake

8.2.2.3. Decreased Sodium Intake: In this experiment, the daily sodium intake is decreased to 0.3 times its normal value. The ECNa concentration and the total body water decrease only slightly, and the body loses about 70 mEq sodium from its EC compartment which causes the MAP to decrease to 96 mmHg. (See Figures 8.24, 8.25 and 8.26). After three days, the sodium excretion rate ($na_out_in_urine$) matches the na_intake , and a new steady state is reached. The graph in Figure 8.26 demonstrates that Renin is increased due to decreased MAP, and the ALD hormone increased accordingly. On the other hand, the ANH and the ADH decreased due to decreased ECF volume, and decreased ECNa concentration, respectively. The resulting urine is more dilute than normal, but its amount is decreased due to decreased sodium excretion.

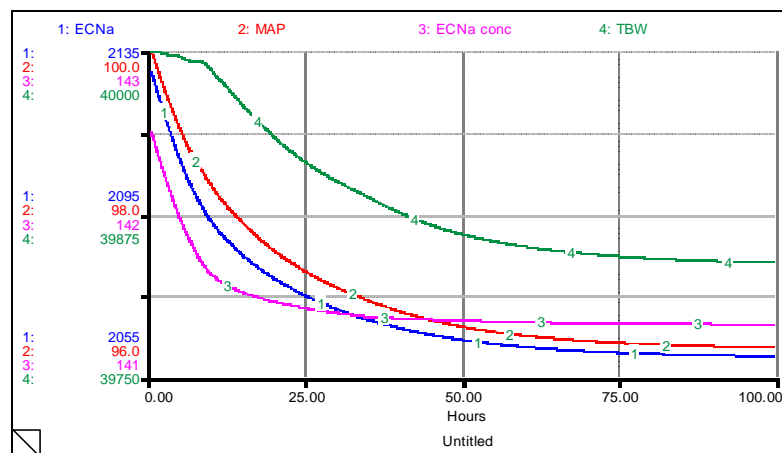

Figure 8.24. Dynamics of key variables in case of decreased sodium intake

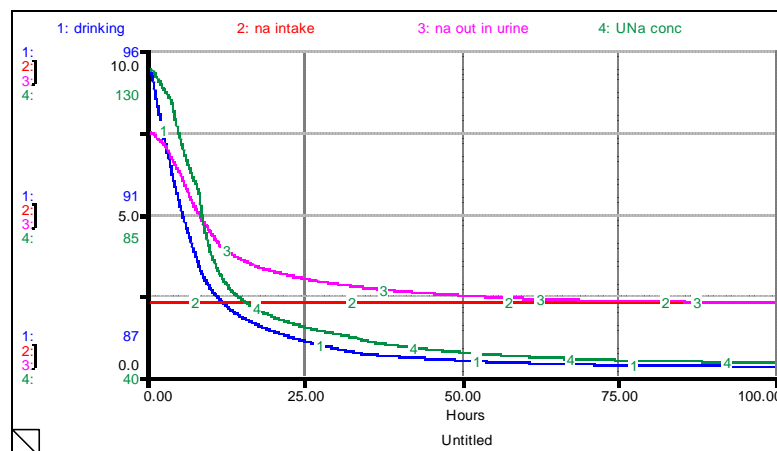

Figure 8.25. Dynamics of key variables in case of decreased sodium intake – cont.

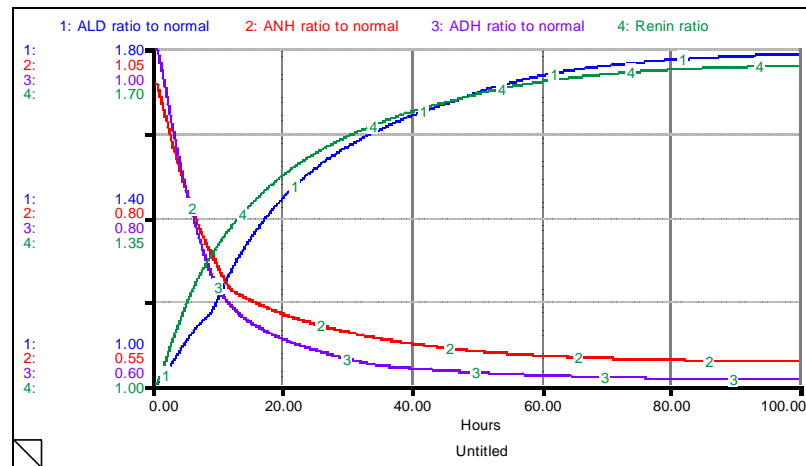

Figure 8.26. Hormonal dynamics in case of decreased sodium intake

8.2.2.4. Sensitivity of ECNa concentration to Different Daily Sodium Intakes: In a normal person, ECNa concentration is controlled with reasonable effectiveness even with large changes in sodium intake, as long as water intake is enough to balance the losses (Guyton, 2000). In this experiment, the effectiveness of body feedback mechanisms to control the ECNa concentration is investigated. The system is initialized with all variables being at their normal levels, and sodium intake is varied between 0.2 of normal salt intake and 5 times normal intake, a range of 25-fold. It is seen that ECNa concentration is kept within 1% control limits when all feedback systems are intact (See Figure 8.1 and Table 8.2).

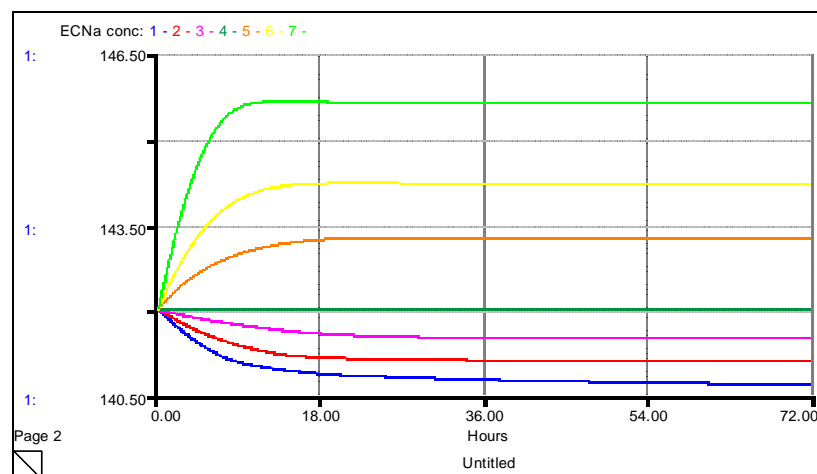

Figure 8.27. Sensitivity of ECNa concentration to different daily sodium intakes

Table 8.1. Simulated levels of ECNa concentration with different daily sodium intakes

Runs	Dietary Sodium (times normal)	ECNa concentration
1	0.2	140.63
2	0.5	141.11
3	0.8	141.5
4	1	142
5	2	143.27
6	3	144.23
7	5	145.66

In the second experiment, the effect of ADH-thirst feedback system on ECNa concentration is investigated. The experiment is repeated by blocking the ADH and then the thirst systems, and it is seen that each one of the ADH and the thirst systems can control the ECNa concentration on their own with reasonable effectiveness. On the other hand, if both of them are blocked simultaneously, ECNa concentration changes tremendously from its normal value, as expected (See Figures 8.28 and 8.29).

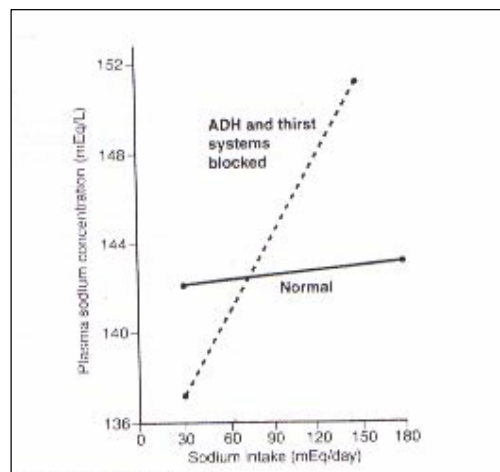

Figure 8.28. Effect of changes in sodium intake on ECNa concentration (1) under normal conditions (2) after the ADH-thirst feedback has been blocked - from Guyton (2000).

As mentioned in Sections 7.3 and 7.4, ALD is important in regulating sodium excretion by the kidneys. This may lead one to believe that ALD also plays an important role in regulating ECNa concentration. Thus, in the third experiment, the effect of ALD feedback on ECNa concentration is sought, and so the experiment is repeated by blocking the ALD feedback (See Figures 8.29 and 8.30). It is seen that ECNa concentration is almost

equally well controlled with or without ALD feedback control, which demonstrates that the ECNa concentration is mainly controlled by the ADH-thirst system, and ALD has little effect on the ECNa concentration, except under extreme conditions.

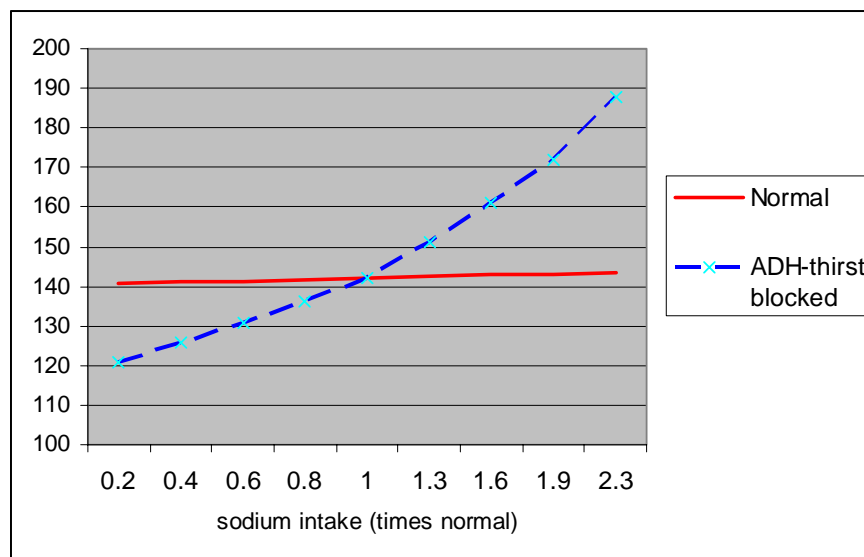

Figure 8.29. Simulated effect of changes in sodium intake on ECNa concentration (1) under normal conditions (2) after the ADH-thirst system has been blocked

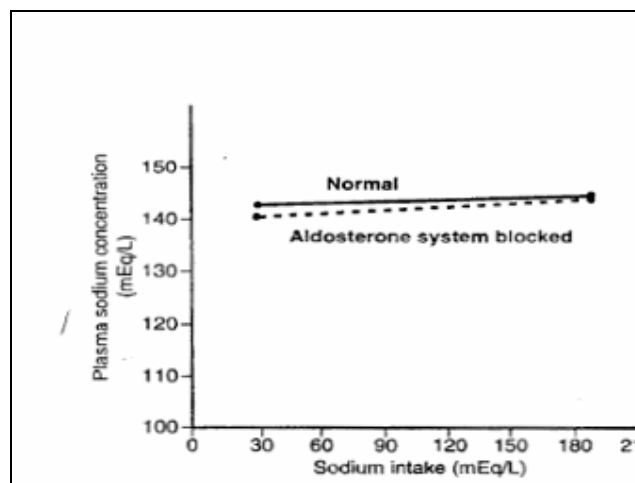

Figure 8.30. Effect of changes in sodium intake on ECNa concentration (1) under normal conditions (2) after the ALD feedback has been blocked-from Guyton (2000).

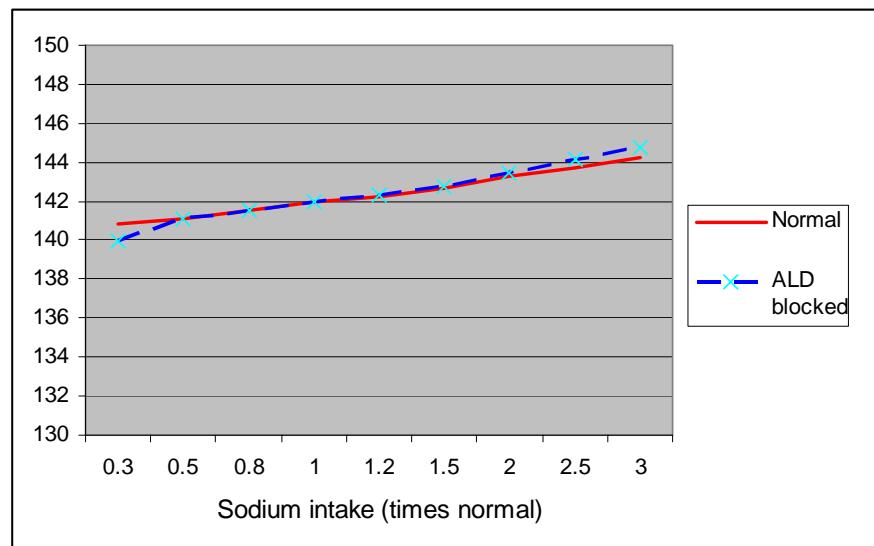

Figure 8.31. Simulated effect of changes in sodium intake on ECNa concentration (1) under normal conditions (2) after the ALD feedback has been blocked.

8.2.3. Abnormal Aldosterone Secretion

8.2.3.1. Loss of Aldosterone: People who are not able to secrete adrenal hormones including the ALD hormone have a disorder that is called Addison's disease. They lose sodium into the urine, and their blood pressure decreases. Addison's disease can be treated by replacing the lacking hormones, and/or increasing the daily sodium intake to match the renal loss of sodium.

This condition is simulated by changing the effect of ALD on sodium excretion. After 2 weeks, almost 7% of total ECNa is lost, the mean arterial pressure fell to 90 mmHg, and the TBW fell about 1 L (See Figure 8.32). On the other hand, the ECNa concentration only slightly decreases from 142 mEq/L to 141,6 mEq/L, as expected. Increasing the daily intake of sodium about 3-fold in addition to the loss of ALD returns the MAP and the ECNa to their normal values. Indeed, Addison's patients have an increased salt-appetite, and their blood volume/pressure does not decrease greatly so long as they have access to salt.

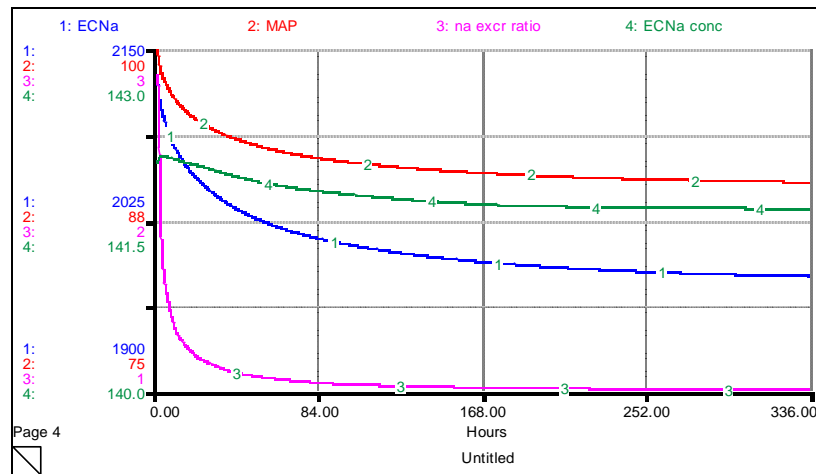

Figure 8.32. Model response of cessation of Aldosterone secretion

8.2.3.2. Aldosterone Loading: The model is simulated to demonstrate the effects of sustained aldosterone (ALD) loading. Experimentally, this loading was achieved with daily injections; however in the simulation the ALD concentration ratio (*ALD_ratio_to_normal*) is simply initialized at four times its normal value and then maintained at this elevated level. The real system behavior can be seen in Figure 8.33, and the model behavior can be seen in Figures 8.34 and 8.35.

Like in the real case, at first there is a sodium retention and volume expansion due to decreased sodium excretion rate (*na_excr_ratio*), but after about 4 days, the *na_excr_ratio* almost increases to its normal level of 1 to match the intake rate, despite the high level of ALD. Therefore no further water retention occurs, and the increase in TBW, ECFV, and thus MAP are limited. This is termed as “aldosterone escape” and it prevents excessive volume increases in patients who excrete excess amounts of ALD (Primary Aldosteronism). Escape from excess ALD is accomplished by the combined increase in the GFR, Filtered sodium, and ANH, which increase as a result of the increased sodium load and water retention and bring the *na_excr_ratio* to its normal level. On the other hand, ECNa concentration hardly changes from its normal value of 142 mEq/L to 143 mEq/L, as expected.

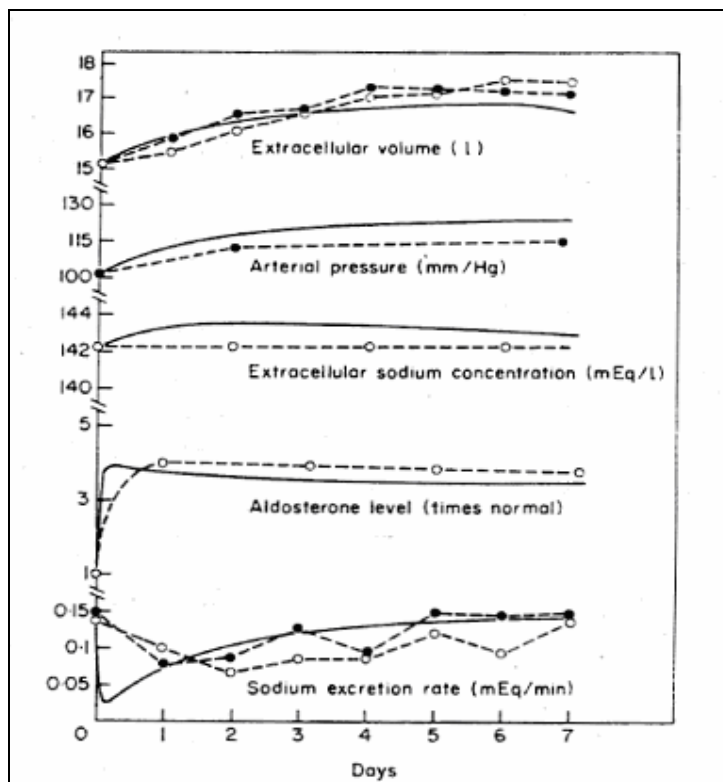

Figure 8.33. Aldosterone loading: Open circles indicate experimental data of Relman and Schwartz (1952); solid circles indicate experimental data of Davis and Howell (1953); taken from Cameron (1977).

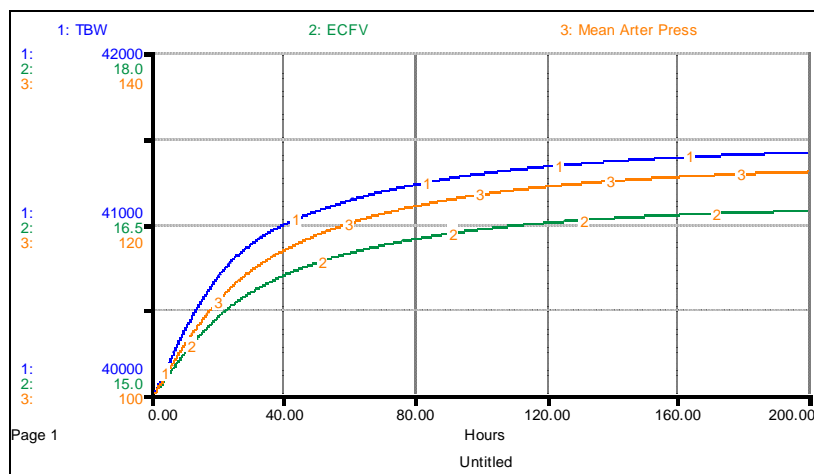

Figure 8.34. Model generated outputs for Aldosterone loading

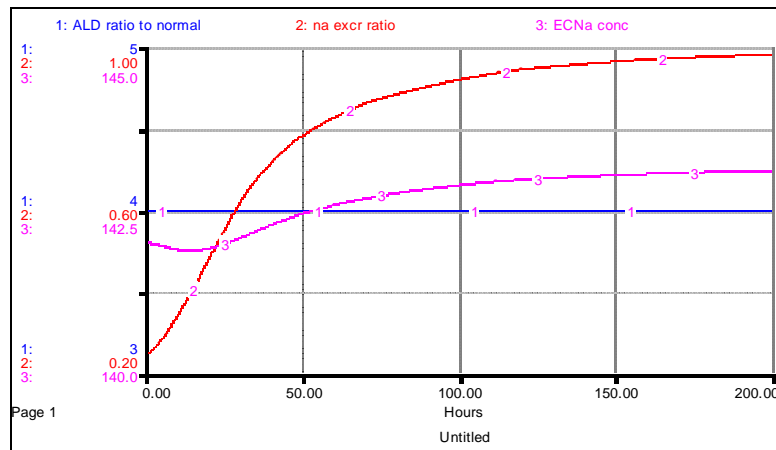

Figure 8.35. Model generated outputs for Aldosterone loading – cont.

8.2.4. Diabetes Insipidus

In this simulation, the extreme example of the absence of ADH production is outlined, which is called DI. The pool capacity of ADH is decreased 90% by changing the *pct_decrease_in_cap* to 90 at time 0. It is seen that the total body water can no longer be conserved, and the ECNa concentration can be kept at an elevated level, as in the reality (See Figure 8.36). On the other hand, the blood pressure is kept constant at its normal level of 100 mmHg.

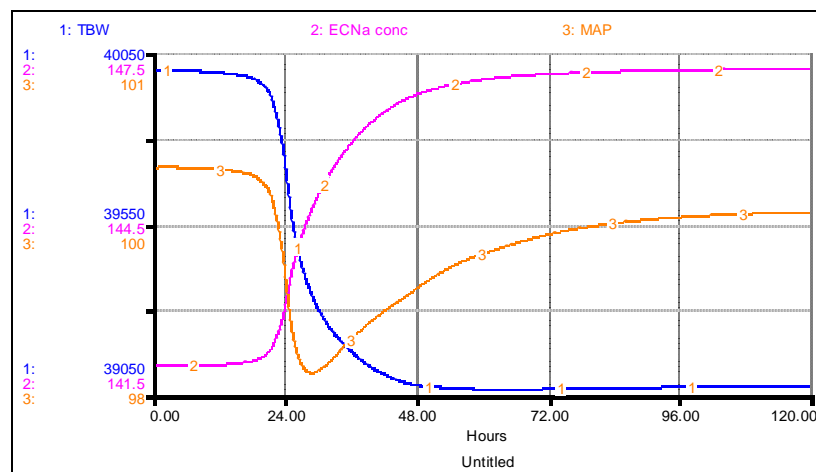

Figure 8.36. Dynamics of the key variables in Diabetes Insipidus - continuous case

In the second simulation, the same condition is simulated to observe the drinking behavior and the urinary excretion of the patient (See Figure 8.37). It can be observed the drinking periods became very frequent (15 times a day), and the urine flow is highly elevated. The UNa concentration is also very low, as expected. This patient loses large amounts of water continuously, and has to drink enough to replace this loss. The daily water turnover of this patient is about 11 liters, which is far greater than the normal value of 2-3 liters.

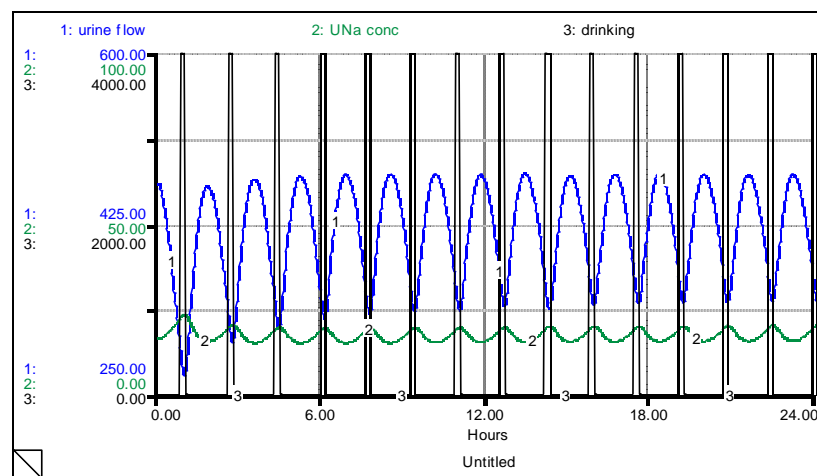

Figure 8.37. Drinking and urinary excretion in Diabetes Insipidus - discontinuous case

8.2.5. Water Deprivation

The model is simulated by decreasing the water intake to 0 (See Figures 8.38 and 8.39). As expected, the TBW, the ECFV, and the MAP decrease; and the ECNa concentration increases continuously. During the first 24 hours of dehydration, ADH amount released increased 3,5 fold, UNa concentration reached its maximum level, and the ECNa concentration is increased only by 7 mEq/L, which is still in the normal range.

However, continued water deprivation cannot further increase the UNa concentration, even when ADH continues to increase. The urine flow can be minimized, but the continuous loss of water due to the insensible losses and the obligatory loss of urine cannot be compensated without an external source of water. At the end of 72 hours, the body lost

4 liters of water, and the ECNa concentration is increased to 165 mEq/L. Since the nonlethal range of ECNa concentration is 115 to 175 mEq/L (Northrop, 2000), it is obvious that a human being can live without water only a few days (See Figure 8.38).

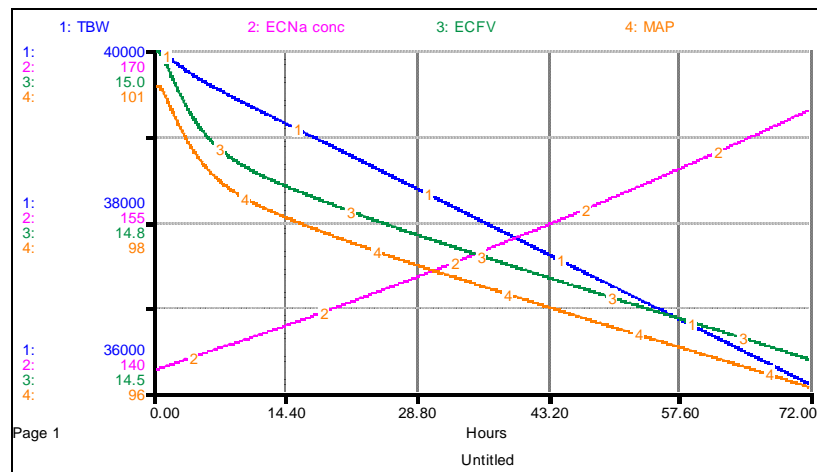

Figure 8.38. The model behavior in case of water deprivation

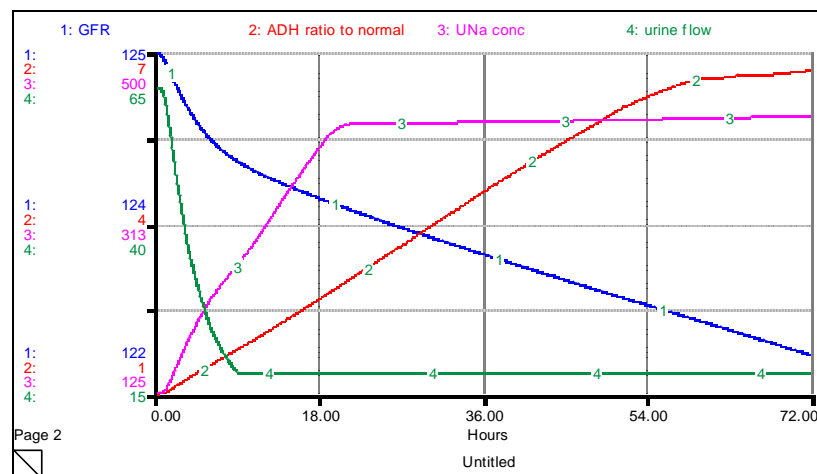

Figure 8.39. The model behavior in case of water deprivation – cont.

8.2.6. Test of the Drinking Behavior

The drinking behavior is tested by dehydration of body water, which is followed by drinking. Figure 8.40 represents experimental data from Adolph (1943), which is taken from Reeve et al., 1967.

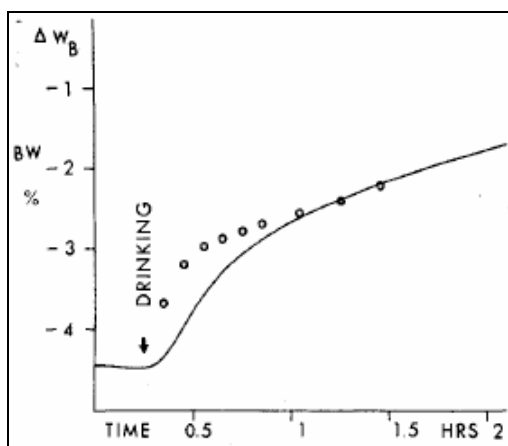

Figure 8.40. Increase in body water by drinking following a dehydration of 4.5 percent TBW. Circles indicate experimental data.

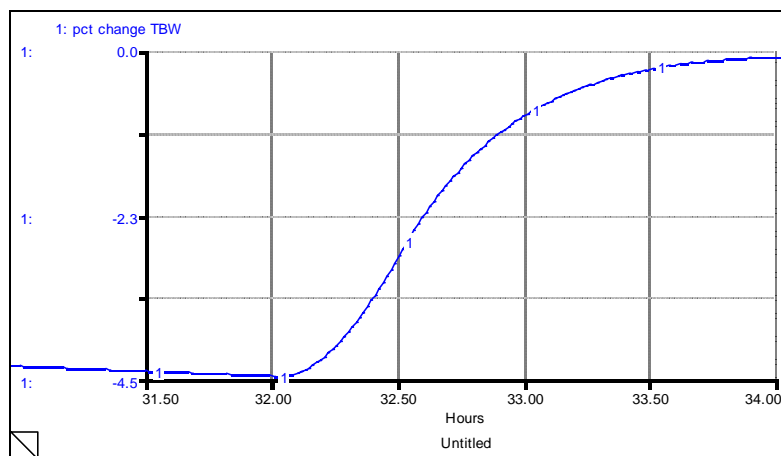

Figure 8.41. Simulation of percent change in TBW by drinking following a dehydration of 4.5 percent TBW

As a result of all the above validity tests the model is found to be a robust representation of the water-electrolyte balance in normal and various test conditions.

9. THE INTERACTIVE DYNAMIC SIMULATOR (BWATERGAME)

The interactive dynamic system simulation game based on the model presented in this study is designed to allow users explore the possible effects of therapeutic interventions for water intoxication/hyponatremia. The software used for developing the game interface is the same as the software used to build the model, that is, Stella. The recent versions of Stella have efficient and suitable features for interactive simulation.

In the first section of this chapter the modifications of the original model are explained. In the second and third sections the modified model is verified, and the game interface is introduced. Finally the fourth chapter presents some examples of played games.

9.1. Modification of the Model

As mentioned in Section 2.2.2, severe chronic symptomatic hyponatremia with an ECNa concentration of 110 to 115 mmol/l occurs most commonly in the SIADH, which is caused by excess ADH secretion or action. Therefore, the modified model that is presented here is constructed to understand the basic features and dynamics of this ADH induced hyponatremia.

The major modifications of the game can be examined in two categories. First, some sectors or structures are added to the original model for representing the treatment options, and the variables for game related measurements. Second, some equations and graphical functions of the original model are modified to incorporate the effects of treatment options or the effects of a disease process (Water Intoxication due to the SIADH).

9.1.1. Structures Added to the Original Model

The modified model has a treatment sector which is composed of three subsectors, i.e. Diuretic, Aquaretic (ADH-Antagonist), and Saline Infusion. Detailed information about the management options of water intoxication/hyponatremia can be found in Section 2.2.2.7.

The drug metabolization structure used in *New Horizons in Virtual Medicine- A Simple Model of Drug Metabolization of High Performance Systems, Inc. (1997)* (See <http://www.hps-inc.com/community/downloads/EducationDownloads.aspx>) is evaluated to be appropriate for the scope of this study. Hence, the drug structures employed in this model are significantly inspired by the one used in this model. However, certain structures are added or modified according to the requirements of this study.

The Diuretic and Aquaretic drug structures are almost identical; they differ only in some graphical functions and initial values of certain parameters. No direct relation is defined between the ADH-Antagonist and Diuretic drugs. The main assumption related to the drug structures is that their effect depends on their concentration in blood. Therefore both of the diuretic and ADH-Antagonist sectors are first responsible for finding the blood concentrations of their own drug category. The effects of drugs are then defined as graphical functions of drug blood concentrations. It is assumed that their effect increases dose-dependently, as suggested by the related literature.

As representative of the almost identical drug sectors, the stock-flow diagram and the causal-loop diagram of the diuretic sector are given in Figures 9.1 and 9.2. Treatment sector group related variables are listed in Appendix B with their brief descriptions and units.

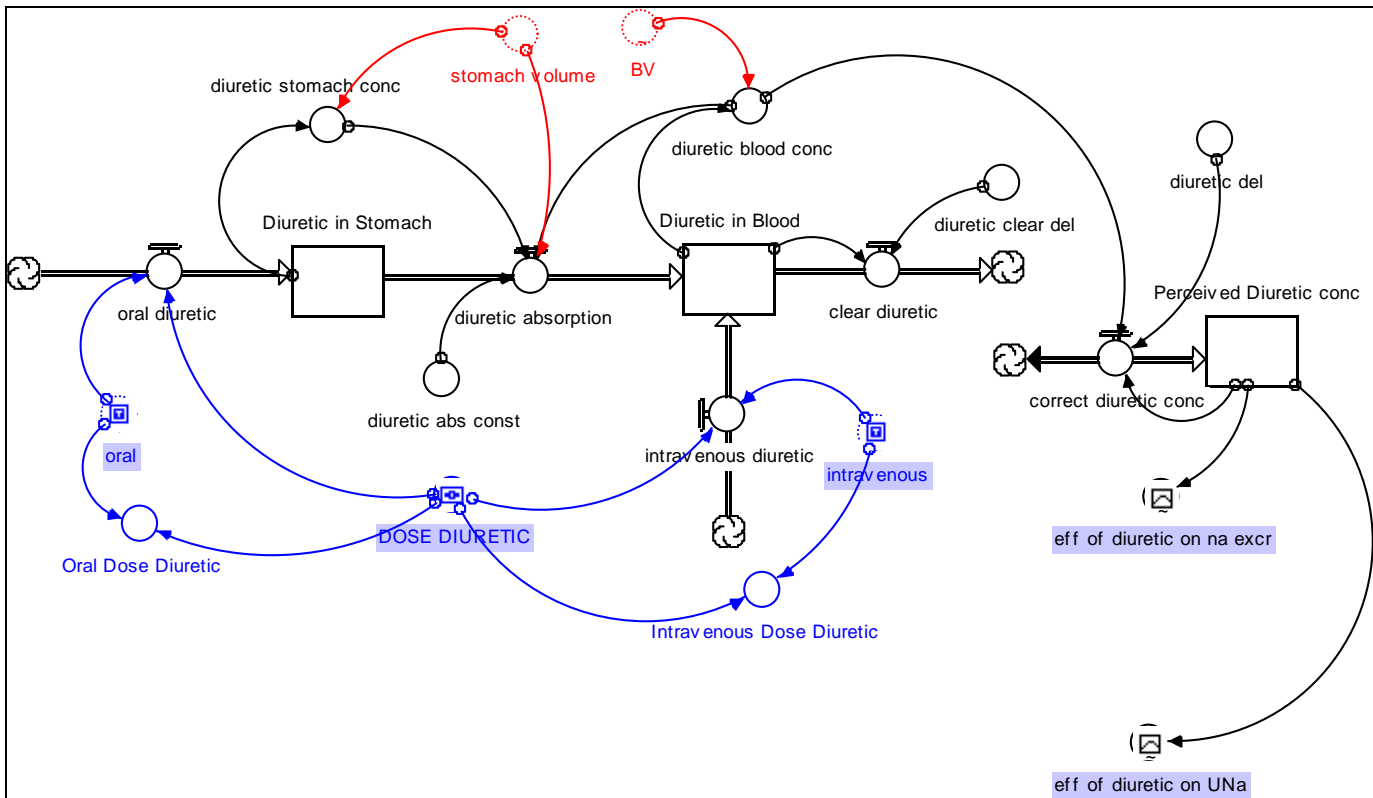

Figure 9.1. Stock-flow diagram of the Diuretic sector

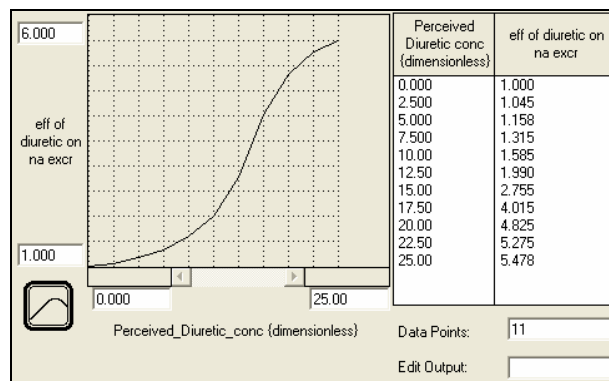

Figure 9.3. Effect of Diuretic on sodium excretion

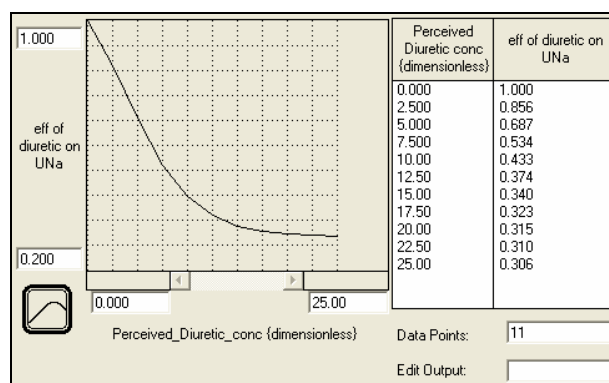

Figure 9.4. Effect of Diuretic on UNa concentration

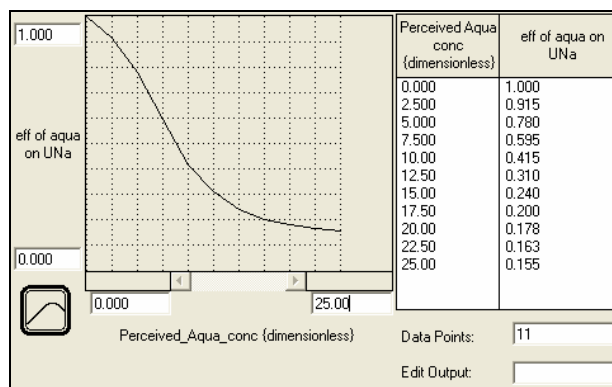

Figure 9.5. Effect of Aquaretic on UNa concentration

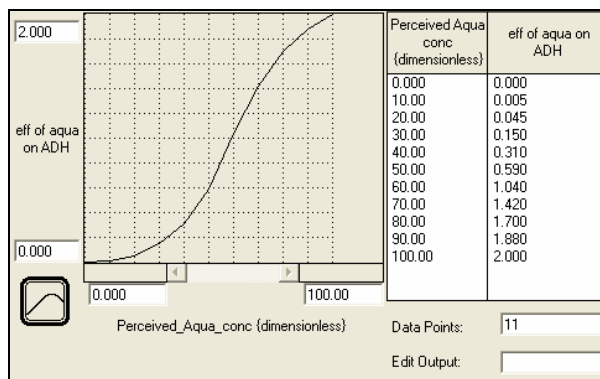

Figure 9.6. Effect of Aquaretic on ADH concentration

The third subsector of the treatment sector group is the Saline Infusion. This structure finds the given amounts of sodium and water according to the type of saline infused. Since the infused water and sodium will be added to the current body water and sodium stocks of the body, two flows are attached to them which are called *water_infusion* and *na_infusion*, respectively.

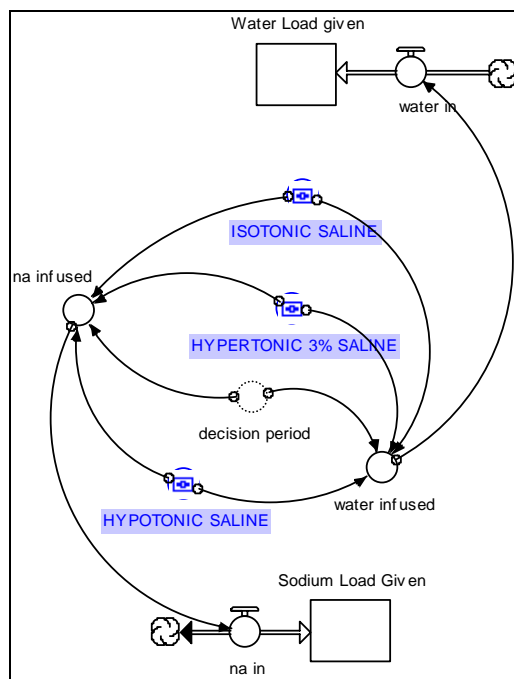

Figure 9.7. Stock-flow diagram of the Saline Infusion Sector

Other structures that are added to the game are related to the measurements of the game variables, finding the hourly and daily EC sodium concentration correction rates, time tracing converters, and initialization variables. The structures related to measurements and correction rates are given in Figures 9.8 and 9.9.

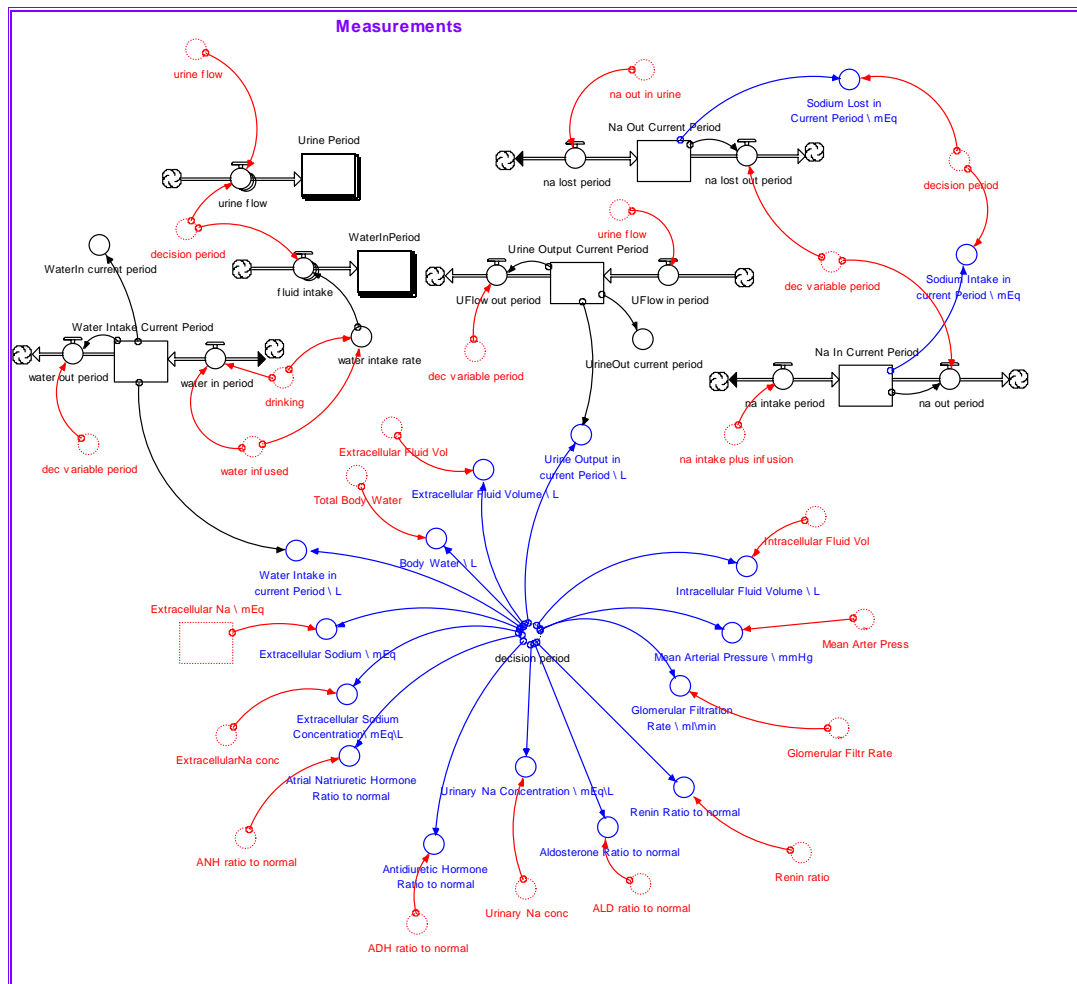

Figure 9.8. Measurements of the Game

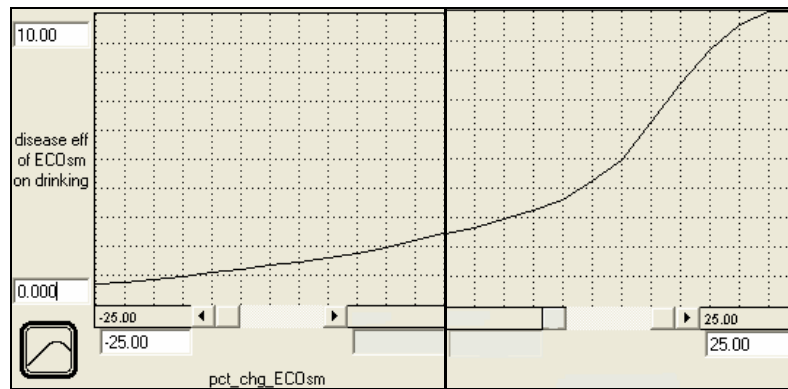

Figure 9.10. Modified effect of EC Osmolality on drinking

The equation for drinking is also modified since a mild or severe water restriction can be imposed on the patient as a treatment option. The modified drinking equation is given in Equation (9.1).

$$\begin{aligned}
 \text{Drinking} = & \text{unrestricted_intake} * (\text{unrestricted_drinking}) + \text{mild_water_restriction} * (\text{IF}(\text{mild}/24) < (\text{unrestricted_drinking}) \text{ THEN}(\text{mild}/24) \text{ ELSE}(\text{unrestricted_drinking})) \\
 & + \text{severe_water_restriction} * ((\text{IF}(\text{severe}/24) < (\text{unrestricted_drinking}) \text{ THEN}(\text{severe}/24) \text{ ELSE}(\text{unrestricted_drinking}))) \quad (8.1)
 \end{aligned}$$

The equations for the UNa concentration are also modified to include the effects of a possible administration of the Aquaretic and the Diuretic drugs. The main difference of these two drug types is that Aquaretics decrease the UNa concentration in all cases, whereas Diuretics only limit the ability of the kidney to concentrate urine. Therefore UNa concentration is only reduced when it is above normal, and when it is below normal, UNa concentration will increase and approach to the normal UNa concentration. Therefore the implied UNa concentration (*implied_UNa_conc*) and the maximal attainable UNa concentration (*max_att_UNa_conc*) are modified, which are given in Equations (9.2) and (9.3). Furthermore, Diuretics also increase the rate of sodium excretion, and the modified sodium excretion rate function (*na_out*) is given in Equation (9.4).

$$\text{implied_Una_conc} = \text{implied_Una_conc_by_ADH} \times \text{eff_of_aquoretic_on_UNa} \times \text{eff_of_GFR_on_UNa} \quad (8.2)$$

$$\text{max_att_UNa_conc} = \text{max_UNa_conc} \times \text{eff_of_diuretic_on_UNa} \times \text{escape} \quad (8.3)$$

$$\begin{aligned} \text{na_out_in_urine} = & \text{Filtered_Na} \times \text{normal_fract} \times \text{eff_of_ANH_on_na_excr} \times \\ & \text{eff_of_diuretic_on_na_excr} \times \text{eff_of_ALD_on_na_excr} \end{aligned} \quad (8.4)$$

9.2. Validation and Analysis of the Modified Model

To verify the new drug sectors of the modified model, they are simulated in isolation. The behaviors exhibited during these isolated simulation runs are easier to interpret, because the number of variables and feedback loops decrease considerably. The results of two isolated simulation runs of the diuretic sector are given in Figures 9.11 and 9.12 as an example. In the first run, an oral dose of Diuretic is administered by using a pulse function of PULSE(100,0,500); whereas in the second run the same dose is administered intravenously.

In the first case, Diuretic concentration in blood increases after a delay, as expected. On the other hand, in the second case intravenous administration of the drug instantaneously increases the drug blood concentration, and the effect of the administered drug appears after almost half an hour.

Another series of simulation experiments were done to test the validity of the treatment options. Yamamura *et al.* (1993) investigated the responses to a series of intravenous doses of Aquaretics in a group of healthy, normally hydrated men. The real cumulative urine volume and the model behavior are presented in Figures 9.13 and 9.14, respectively.

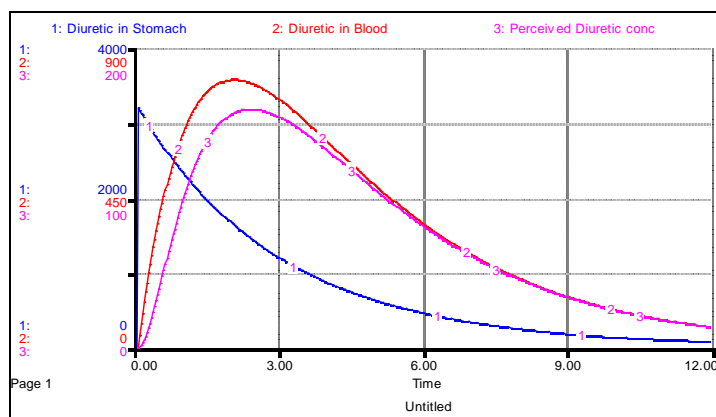

Figure 9.11. Isolated run of the Diuretic sector with an oral dose of Diuretic

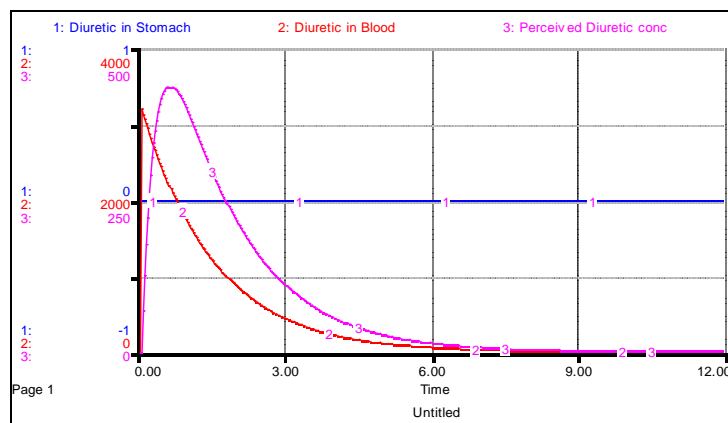

Figure 9.12. Isolated run of the Diuretic sector with an intravenous dose of Diuretic

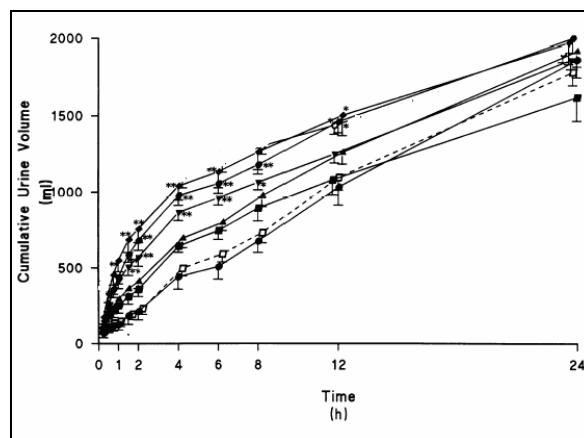

Figure 9.13. Cumulative volume-time relationship of a series of doses of Aquaretic in comparison to placebo (dotted lines) (Modified from Yamamura *et al.*, 1993)

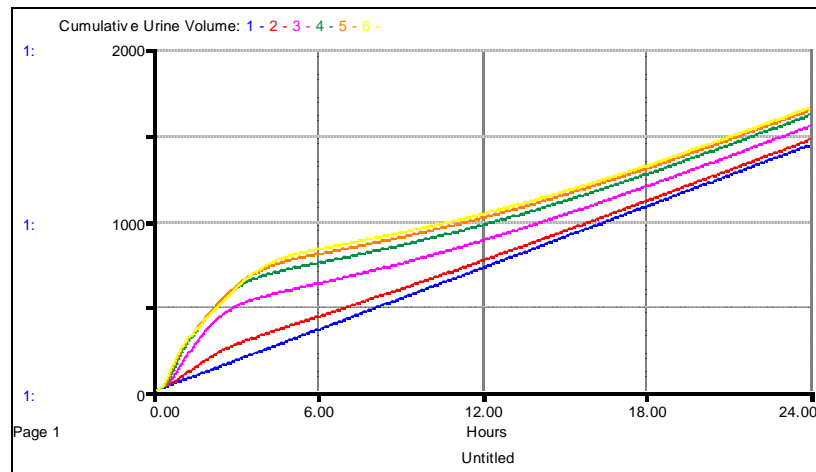

Figure 9.14. Model behavior of cumulative volume-time relationship of one dose of Aquaretic in comparison to placebo (1st line)

After the verification and validation of the newly added structures, the modified model is used to demonstrate the appearance of hyponatremia in the SIADH. To develop hyponatremia, both ADH and the thirst function have to be dysregulated. This fact is demonstrated by simulating the modified model 1st, without changing the thirst function, and 2nd, without changing the ADH function. In the 1st case, increased level of ADH causes retention of water of about 1 liter and a transient loss of sodium, which leads to a decrease in *ECNa_conc*. However decreasing levels of *ECNa_conc* appropriately decreases the thirst function, and the resulting fall in *ECNa_conc* is only 7 mEq/L (See Figures 9.15 and 9.16).

In the 2nd case, an increased level of water intake again leads to water retention and transient sodium loss; however the resulting fall in *ECNa_conc* is only about 1 mEq/L since the response of ADH is more prompt than the thirst response, and the urine flow is increased almost in hours to equalize the water outflow to the its inflow (See Figures 9.17 and 9.18).

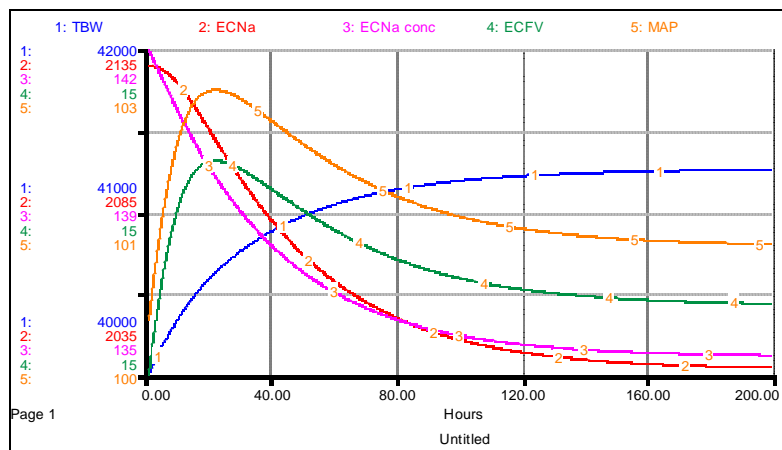

Figure 9.15. Dynamics of key indicators when only ADH is dysregulated

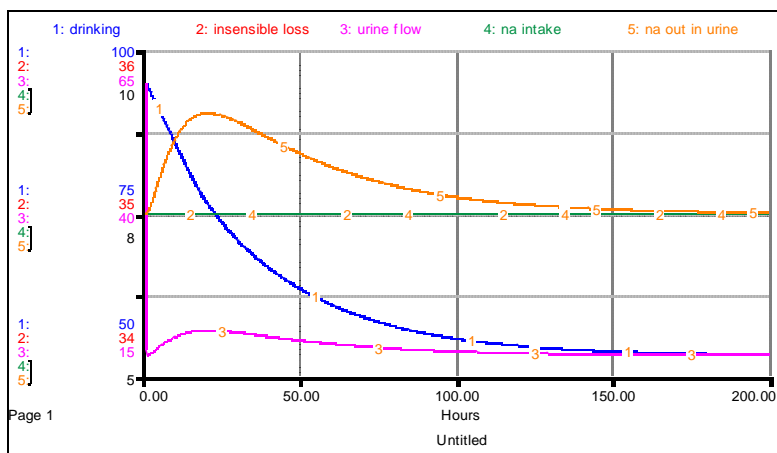

Figure 9.16. Dynamics of water and sodium flows when only ADH is dysregulated

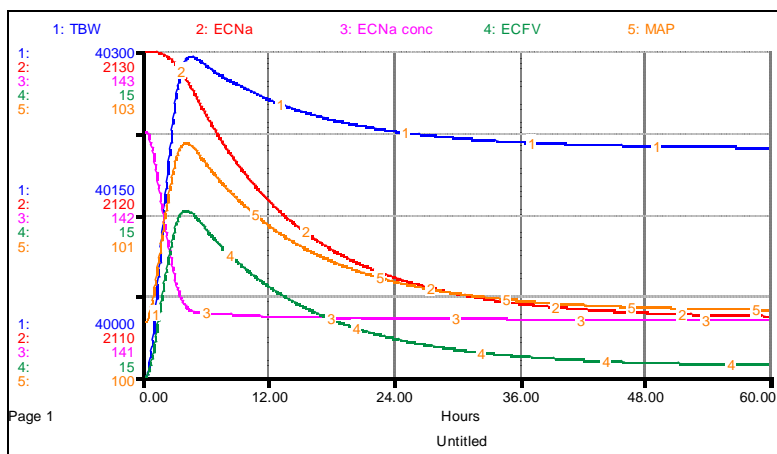

Figure 9.17. Dynamics of key indicators when only thirst is dysregulated

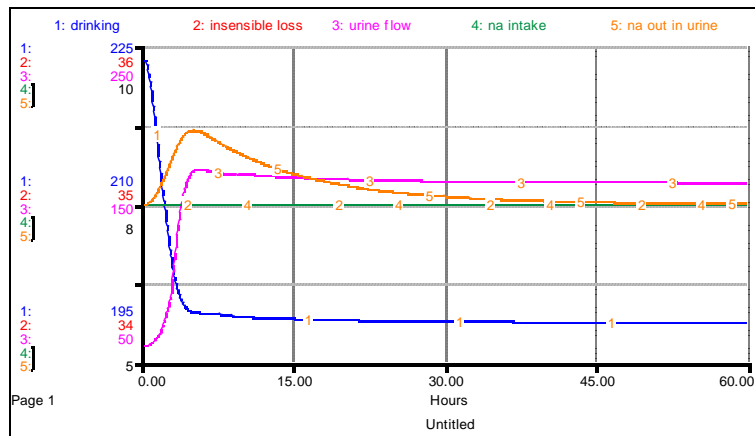

Figure 9.18. Dynamics of water and sodium flows when only thirst is dysregulated

However when both ADH and the thirst function are dysregulated, there is no mechanism that can preserve the level of the body water and the *ECNa_conc*. A series of tests were done by changing the ADH and the thirst function, and it is observed that the severity of resulting hyponatremia depends both on the increase in the plasma ADH level and the response of the thirst function curve. An example dynamic for the appearance of hyponatremia are given in Fig 9.19 and Fig 9.20. In five days, the *ECNa_conc* of the patient falls to 120 mEq/L, and the *TBW* is increased by about 5 liters. Since a steady-state is not reached yet, the *ECNa_conc* continues to decrease. The final values of this simulation are used for the initialization of the game.

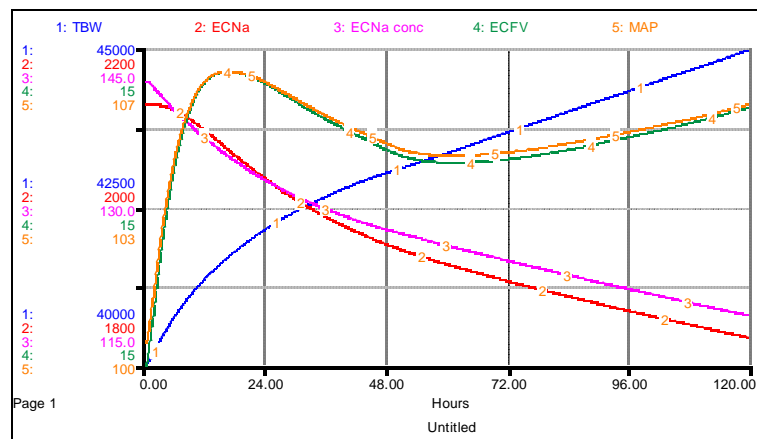

Figure 9.19. Appearance of hyponatremia when both ADH and the thirst functions are dysregulated

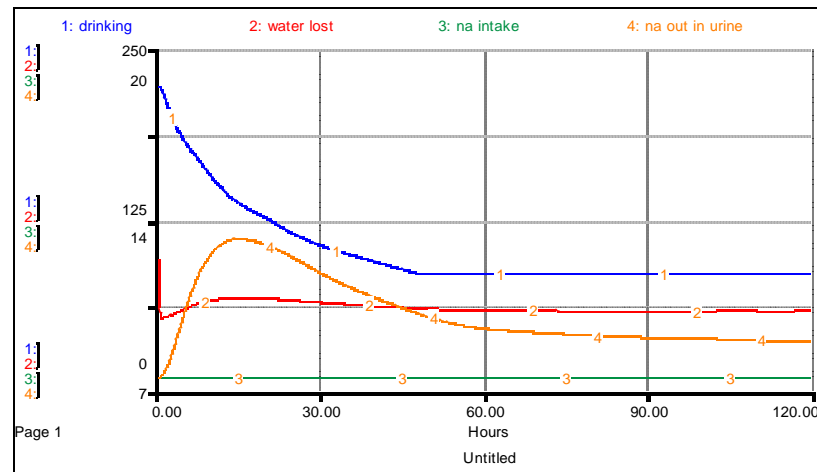

Figure 9.20. Dynamics of water and sodium flows when the ADH-thirst mechanism is dysregulated

9.3. Game Description

The player plays the part of a physician, who is trying to treat a hyponatremic patient by seeking a delicate balance among weighing the risks of hyponatremia itself and those associated with rapid correction of hyponatremia. The decisions made by the player are:

- A. Dose Diuretic:** Diuretics are occasionally used in hyponatremic patients to block the ability of ADH to concentrate the urine at high ADH levels. The player decides the dose given to the patient orally or intravenously (directly to the bloodstream).
- B. Dose Aquaretic (ADH-Antagonist):** Aquaretics decrease urinary concentration and thereby increase the urine flow rate. The player decides the dose given to the patient orally or intravenously.
- C. Isotonic Saline:** This solution has a sodium concentration similar to that of the normal plasma, i.e., 142 mEq/L. The player decides the amount infused to the patient in the current decision interval.

D. Hypotonic Saline: Hypotonic solutions have an osmolality smaller than the “normal” EC osmolality. Hypotonic solutions are considered less dangerous in fluid therapy in general.

E. Hypertonic Saline: Hypertonic saline 3% has an osmolality three times that of plasma.

The primary goal is to increase and sustain the ECNa concentration to its normal levels. At the same time, the total body water content should be decreased to its normal value and the amount of sodium lost should be replenished. The challenge is to achieve these goals in balance, since rapid correction of severe hyponatremia can cause brain demyelination, which may produce neurological morbidity and mortality.

The game is designed as a series of screens, which are combined to each other. The opening screen displays the title of the game and the main menu items, which are listed as follows:

- A. Background
- B. Game
- C. Explore Model

The main screens are described below:

9.3.1. Game/Control Panel Screen

After the “Game” button is pressed the main game screen appears (Figure 9.21). On the top left corner of the screen there are two information buttons, which let the player to reach brief descriptions about the game and the treatment options during the game when they are pressed.

On the bottom right corner of the screen, the game controls are displayed. The game is initiated by pressing the Start button in the New Game frame that is displayed at the bottom right corner of the screen.

On the left side of the screen, the Decision Sliders are displayed. The player enters his decisions by dragging the slider knob to the left or right using the cursor or by entering in the small box below the slider knob. After the decisions are made, the Advance button should be pressed. When this button is pressed the simulation advances 4 hours (which is the default value and can be changed in the scenario settings) and the new values of the variables are calculated. The simulation will pause automatically every 8 hour to let the player change his decision settings and review data. Pressing the Record of Decisions button on the top of the screen enables the player to examine the history of the decisions in a graphical and tabular format.

Once a decision value is changed from its original value, a “U” appears at the bottom-left corner of the slider. Clicking on it will reset the value to sliders’ original value. Clicking on the “?” buttons on the sliders enables the player to reach more information about the associated decision variable.

The total duration will be 120 hours, or 30 decision rounds. At the beginning of the game, you can increase the decision period (or the pause interval) of the simulation from its default value of 8 hours to 4 or 12 hours. The simulation time can be traced through the displays that are located on the top right corner of the screen. At any time, the player can quit the simulation by pressing the End Game button that is displayed at the bottom right corner of the screen.

To start a new game the player should first terminate the current game pressing the End Game button. Next, the model should be initialized to its original setting pressing the Reset button in the New Game frame. Then a new game can be started pressing the Start button in the same frame. Between two sequential games the model must be “Reset” first! Otherwise the Start button would not work properly.

On the middle of the screen, the main indicators (variables related to body water and sodium, hormonal indicators and other measures) are displayed in order to give the player feedback about the major variables. Pressing the “Graph” buttons on the right or bottom of these variables, the dynamic behavior pattern of that variable can be displayed. On the right side of the screen, three main indicators are displayed as warning devices, for which three distinct zones are set - normal, caution, danger. As the value of the variable passes through these zones, the warning device displays the color associated with that zone – green, yellow and red, respectively. Pressing the “?” buttons on the right of the variables, brief descriptions of those variables can be displayed.

9.3.2. Model Overview Screen

“Explore Model” button that is displayed on the right corner of the opening screen executes the link to the “Model Overview Screen” (Figure 9.22). The purpose of this screen is to give the player information about the interactions between the variables in the model.

This is a high-level overview of the model, which shows the sectors in the system and the physical (thick arrows) and information (thin arrows) flows between them.

Clicking on the lower portion of the corresponding sector frame takes the player to the modeling layer and enables him to trace out the model for a particular sector one at a time. Clicking on the dots would reveal the model structure. To return back to the high-level map, the upward-pointing triangle in the left-hand margin of the window should be clicked.

The whole sector at a snapshot can be viewed by clicking the downward pointing triangle at the top right corner of the sector frame. The player can return to the high-level map by pressing the Back buttons, which are displayed on the modeling layer. The Control Panel button on the bottom of the screen takes the player back to the main game screen.

9.3.3. Varying the Scenario Screen

Clicking on the Vary Scenario button displayed on the bottom of the screen takes the player to the screen where the drug effects, the decision period setting and the water intake decision are listed (Figure 9.23). Varying these variables in different combinations lets the player to play the game under different drug types corresponding to the same category. A “mild” or “severe” water restriction could also be imposed to the patient between runs. At the beginning of the game, you can increase your decision period from its default value of 4 hours to 6 or 8 hours.

To change the predefined relations the player should click one of the graphical functions and change the shape of the function. If you change a graphical function, a small "U" button appears in the lower left corner. To restore the function to its original shape, you should click once the "U" button. If you need more information, you should click once on the question mark (?) button at the bottom. Clicking once on the question mark button at the bottom of the knob enables the player to reach more information about the associated function.

These conditions can not be changed during the game but “Varying the Scenario Screen” can be visited to check what the conditions are.

9.3.4. General Information About the Model Screen

Clicking on the Background button in the opening / main menu screen takes the player to the “General Information about the Model” (Figure 9.24). The purpose of this screen is to give the player brief information about the model, hints and warnings.

9.3.5. General Information About the Sliders Screen

Clicking on the About Controls button in the Control Panel takes the player to the “General Information about Input Sliders” Screen (Figure 9.25). The purpose of this screen is to give the player general information about the use of the sliders.

9.3.6. End Game Screens

Clicking on the End Game button initiates quitting process. Before exiting the game, the player will be asked to save the game results in a file. If the player chooses to save the game results, he will be asked to enter a name for the file, which will keep the data of the current game results. It must have the extension “.stm” in Windows environment.

Treatment Options

Instructions

Control Panel

decision interval
 hours
 period

Drug Infusion ?

oral
 intravenous

DOSE DIURETIC

DOSE ADH ANTAGONIST

Fluid Therapy ?

ISOTONIC SALINE

HYPERTONIC 3% SALINE

HYPOTONIC SALINE

Key Indicators

Body Water

Total Body Water	47.1	?	[Liter]
Extracellular Fluid Vol	18.1	?	[Liter]
Intracellular Fluid Vol	31.0	?	[Liter]

Units:

Mean Arter Press	119	?	[mmHg]
WaterIn current period	1.8	?	[Liter]
UrineOut current period	0.9	?	[Liter]

ExtracellularNa conc
?

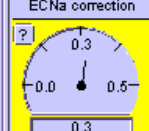
115

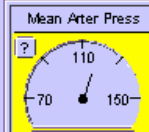
ECNa correction
?

0.3

Mean Arter Press
?

119

Body Sodium

Extracellular Na	1880	?	[mEq]
ExtracellularNa conc	115	?	[mEq/L]
Urinary Na conc	275	?	[mEq/L]

Glomerular Filtr Rate	133	?	[ml/min]
Na In Current Period	216	?	[mEq]
Na Out Current Period	246	?	[mEq]

Hormonal Indicators

Renin ratio	0.1	?	[]
ALD ratio to normal	0.4	?	[]
ADH ratio to normal	2.9	?	[]
ANH ratio to normal	6.1	?	[]

About Controls

Record of Decisions

Vary Scenario...

New Game

Main Menu

Figure 9.21. Game/Control Panel Screen

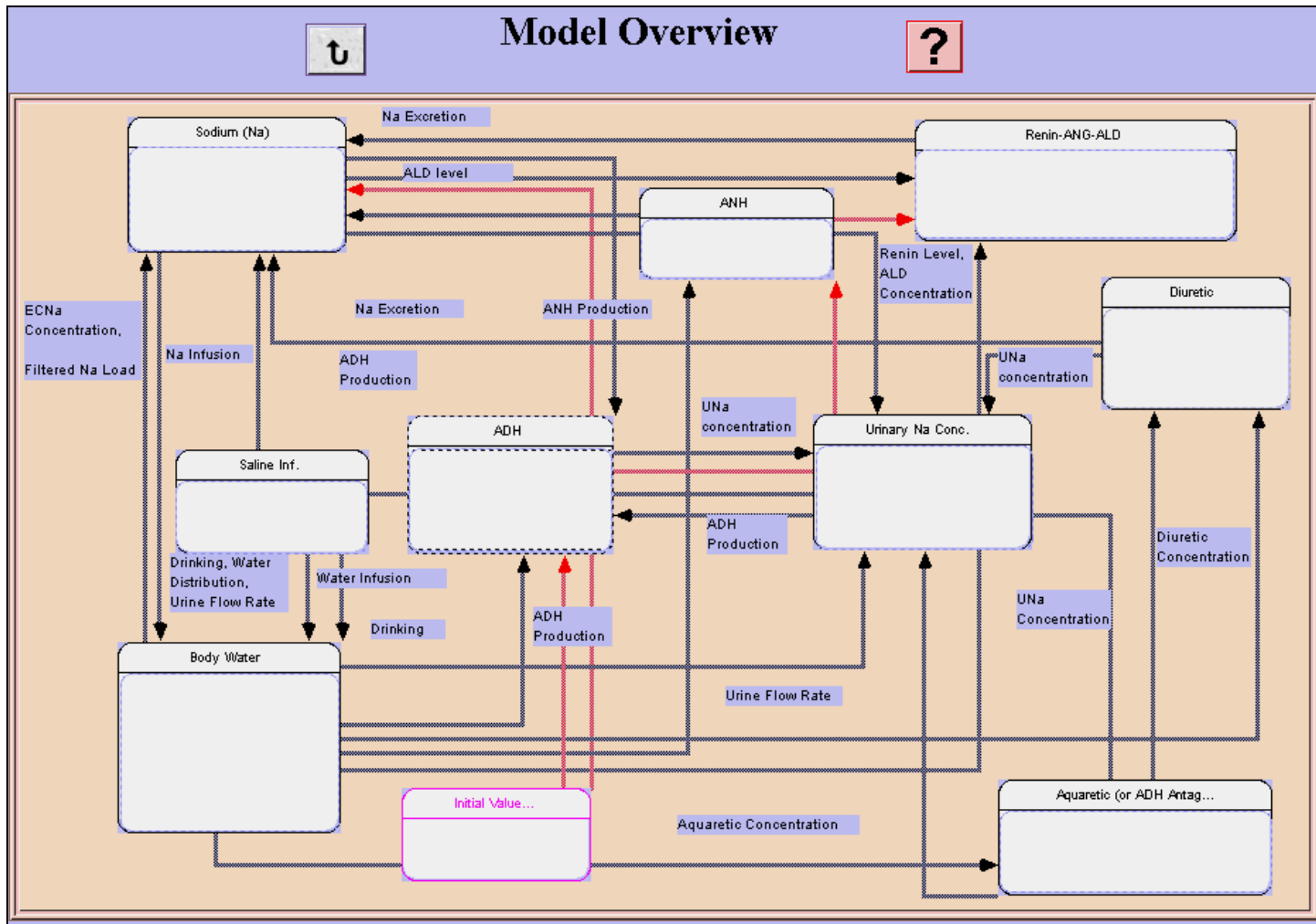

Figure 9.22. Model Overview Screen

DIFFERENT SCENARIOS

↶

Decision Interval ?

eight hours
 four hours
 twelve hours

Water Intake ?

unrestricted intake
 mild water restriction
 severe water restriction

**Sodium Excretion
Sensitivity to Diuretic**

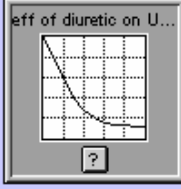
?

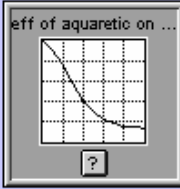
**UNa Sensitivity to
Diuretic**

?

**UNa Sensitivity to
Aquaretic**

?

TO THE MAIN MENU

In the upper left corner you can decide to your decision interval, which is the duration for your next intervention. In the upper right corner you can define the water intake decision for the course of treatment. You can control/restrict the amount of water intake by clicking "mild" or "severe" water restriction. If you don't change it, the default scenario is "unrestricted" water intake.

In the lower portion, you can see the variables that define the drug effects. Varying these variables in different combinations lets the player to play under different drug types corresponding to the same category.

Figure 9.23. Varying the Scenario Screen

General Information About the Model



About the Game

The Game for Body Water Disorder Therapy (BWaterGame) is an interactive dynamic simulator for medical management of a disturbance in salt and water balance, namely water intoxication or hyponatremia, which can be defined as a reduced level of Extracellular Sodium concentration (ECNa_conc.)

The regulation of water balance is important in almost every area of medicine. Pathologic conditions associated with water metabolism are generally manifest by disturbances in extracellular sodium concentration (dysnatremias). These disorders relate to deficiencies or excessive secretion of Antidiuretic Hormone (ADH), whose primary function is to control the Extracellular Sodium Concentration (ECNa_conc) by varying the urine flow rate and urine osmolality.

The underlying model of the simulation game is developed using System Dynamics methodology. The player plays the part of a physician, who is trying to treat a hyponatremic patient with an ECNa conc. of 120 mEq/L and an excess body water of about 5 lt. Please note that the

Hints and Warnings

The values in decision sliders are set at zero at the beginning of the game. To adjust the slider input devices, the player has simply move the slider to dose the patient. The slider will automatically reset itself after each decision period, except the saline infusion decision. The daily water intake decision does not change if you don't change it in the decision rounds. The player should revise his decisions at each step, by making use of the provided analysis tools.

Results will be displayed in the graphs. You will also receive periodic messages from the patient and your peers.

Please keep in mind that the amount of saline decided to be given to the patient will be infused during the decision period, e.g. if you decide to give 1000 ml of isotonic saline when your decision period is 8 hours, the amount of saline to be given during that 8 hour period is 1000/8 ml per hour.

Figure 9.24. General Information About the Model Screen



General Information About Input Sliders

Drug Dosage Given



Daily Fluid Intake



Isotonic Saline Infusion

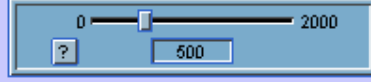

When you navigate to the Control Panel of the medical simulator, you will find input sliders similar to those shown at left. You can use these practice sliders to familiarize yourself with their operation.

To change an input value, use the cursor to drag the slider knob to the left or right (go ahead and try setting the drug dosage given to 60 mg. You'll notice that once you change a value from its original value, a U appears at the bottom left corner of the slider. Clicking on it will reset the value to its original value (try it).

If you want information about each of the input variables, click on the associated (?).

Figure 9.25. General Information about Input Sliders Screen

9.4. More About the Game

The values in decision sliders are set at zero at the beginning of the game. To adjust the slider input devices, the player has simply move the slider to dose the patient. The slider will automatically reset itself after each decision period, except the saline infusion decision. The daily water intake decision does not change if the player doesn't change it in the decision rounds. The player should revise his decisions at each step, by making use of the provided analysis tools.

Results will be displayed in the graphs. The player will also receive periodic messages from the patient and your peers.

The player should keep in mind that the amount of saline decided to be given to the patient will be infused during the decision period, e.g. if you decide to give 1000 ml of isotonic saline when your decision period is 8 hours, the amount of saline to be given during that 8 hour period is $1000/8$ ml per hour.

The EC and IC fluid osmolalities (EC_{Os}m and IC_{Os}m) are always identical. In the model it is assumed that the EC_{Os}m is proportional at all times to EC sodium concentration, and IC_{Os}m proportional to IC potassium conc. Amount of potassium is taken as constant, only sodium amount can be changed by purpose. Sodium and potassium are assumed to be locked in their respective compartments, and only water can cross the boundary to equalize the osmolalities. It is assumed that within the timescale of the model water is transferred between the EC and the IC pools instantaneously to ensure osmotic equilibrium.

The most important physiologic action of ADH is to influence the rate of urine flow by promoting concentration of urine. A change in ADH level immediately causes a change in urine flow and concentration. The urine flow is automatically calculated as inversely proportional to urinary sodium concentration, so that a given amount of sodium excretion

rate is conserved. The amount of sodium excretion is on the other hand determined by ALD and ANH, and the filtered load of sodium (which is equal to the $GFR \times ECNa$ concentration).

Excess secretion of ADH alone is not sufficient to produce hyponatremia, thirst has also to be dysregulated. Normally, thirst response has to decrease with decreasing ECNa Conc. and increasing body water. However, for reasons not well understood, SIADH patients continue to drink and this, combined with high ADH levels, leads to hyponatremia.

9.5. Results of the Game Tests by Players

The game was played by five graduate students of Industrial Engineering Department of Boğaziçi University. Each of these players played the game several times and applied different strategies in their trials.

The following figures represent the dynamics of the key measures obtained from a representative player. Figure 9.25 and Figure 9.26 show the player's drug and saline infusion decisions during his trial. He has applied both Diuretics and Aquaretics in this trial. Figure 9.27 and Figure 9.28 display the dynamics of the ECNa concentration and the UNa concentration in the representative player trial. The dynamics of body water compartments and mean arterial pressure can be seen in Figures 9.29-32. Urine output dynamics are displayed in Figure 9.33. In addition to these, the hourly and daily ECNa correction rates can be seen in Figures 9.36 and 9.37 show the hormonal dynamics of ANH, Renin, Aldosterone and ADH. Finally, Figure 9.38 represents the daily water intake dynamics of the patient during this trial.

As can be seen from the figures below, the representative player initially was unable to prevent the decline of the ECNa concentration to levels below 115 mEq/L, but then he succeeded to increase it to mildly hyponatremic levels towards the end of the game. He used a combination of Aquaretics and Diuretics to increase urine flow via a decreased UNa concentration, and also applied a combination of hypertonic and isotonic saline during his

trial. The total body water first increased by 1.5 L, and then it tended to decrease. At the end of the game, the simulated patient still has about 4 L of excess water. The EC fluid volume and hence the mean arterial pressure always stayed above their normal values due to saline infusion and excess body water. Both the hourly and the daily correction rates were between their normal health limits during simulation. The daily water intake of the patient first decreased, and then continuously increased. The player first wrongly chose to give hypertonic solution without drugs, but this only resulted in a fall in ECNa concentration and a rise in blood pressure. Hypertonic saline combined with urine flow increasing drugs later caused an elevated sodium balance and negative water balance.

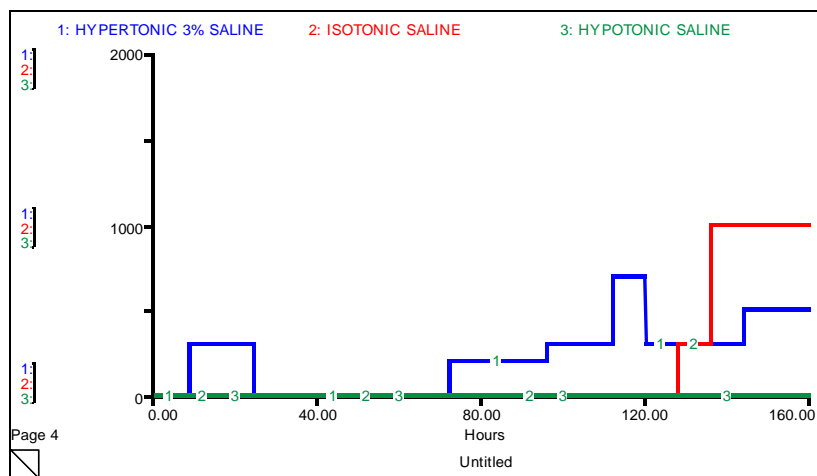

Figure 9.26. Saline infusion decisions of the representative player

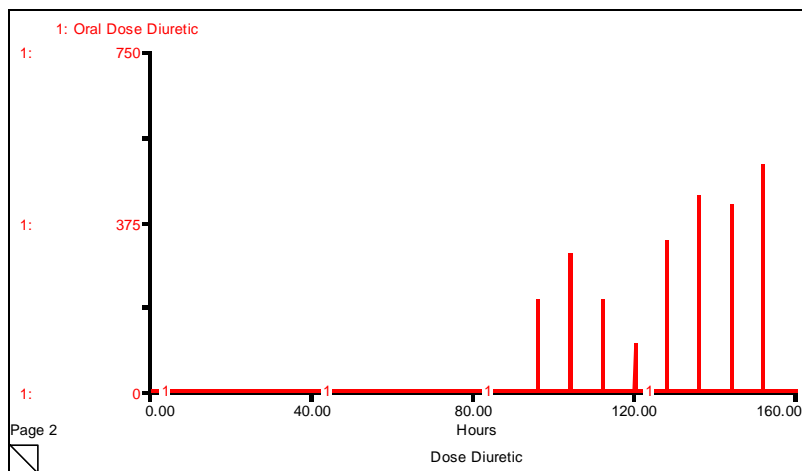

Figure 9.27. Diuretic decisions of the representative player

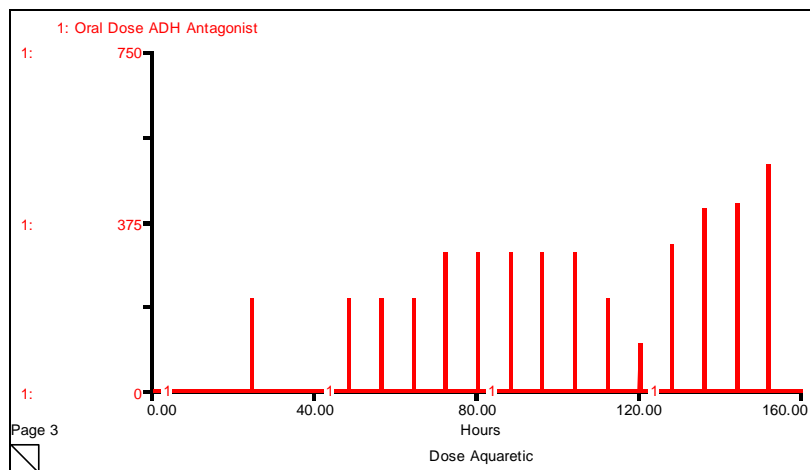

Figure 9.28. ADH-Antagonist decisions of the representative player

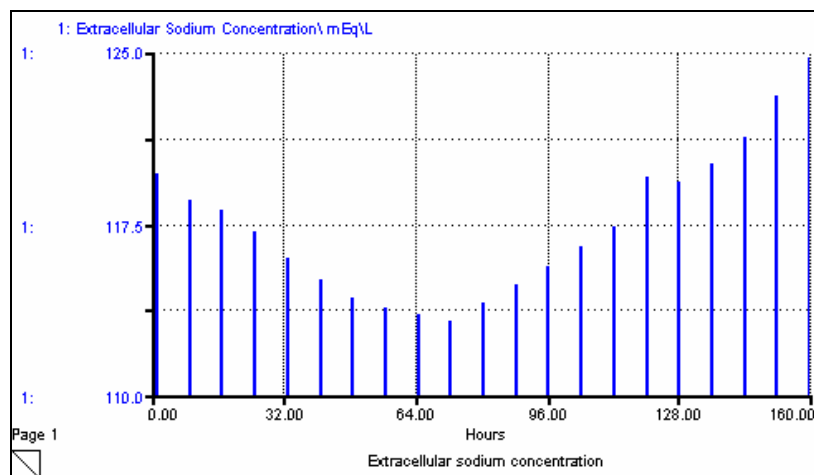

Figure 9.29. Dynamics of ECNa concentration for the representative player

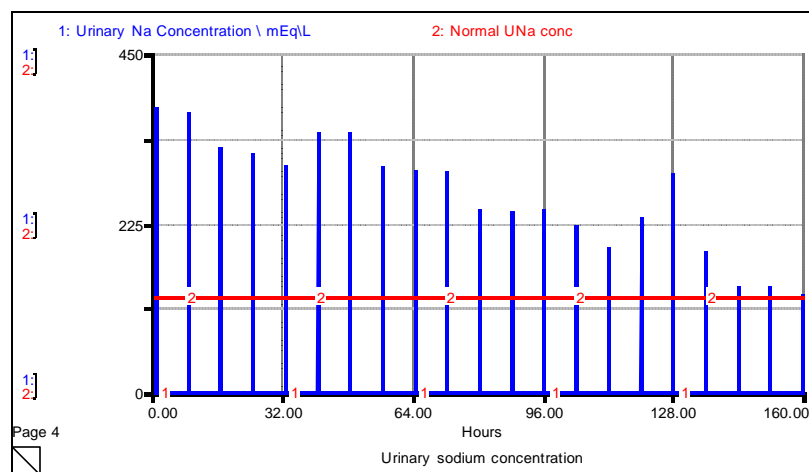

Figure 9.30. UNa concentration dynamics for the representative player

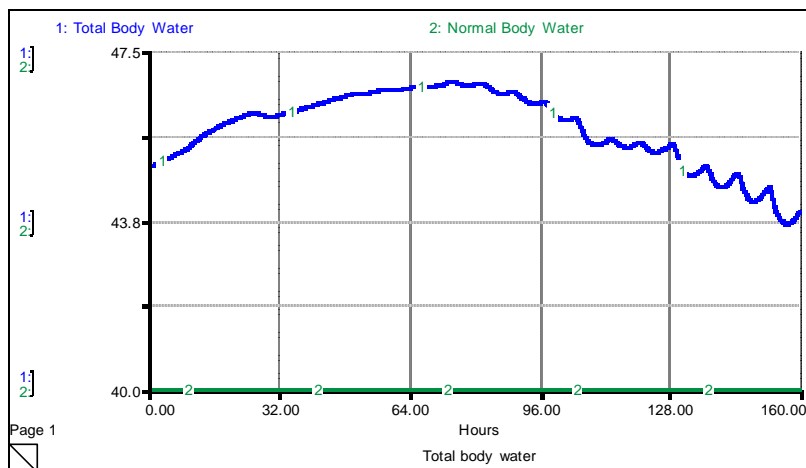

Figure 9.31. Dynamics of total body water for the representative player

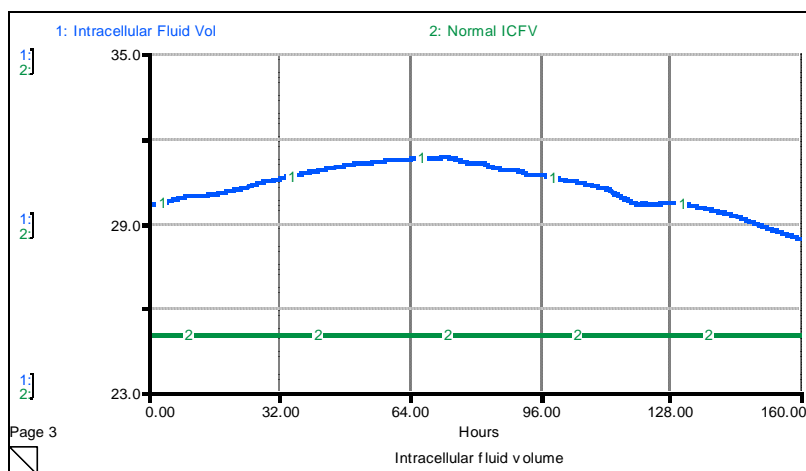

Figure 9.32. Dynamics of IC fluid volume for the representative player

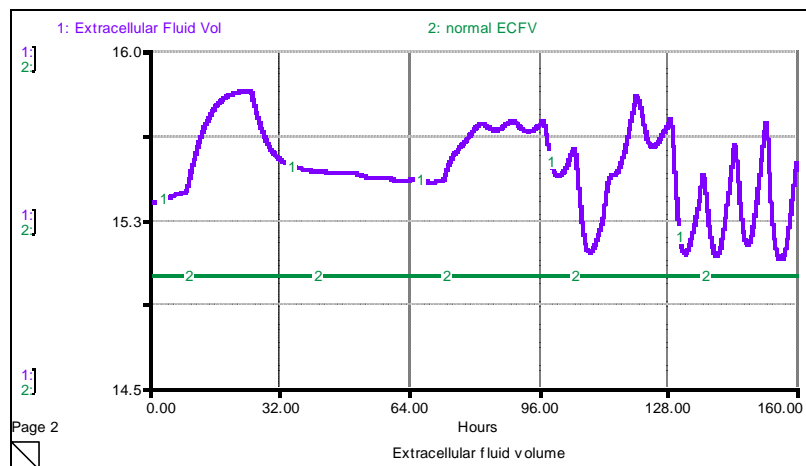

Figure 9.33. Dynamics of EC fluid volume for the representative player

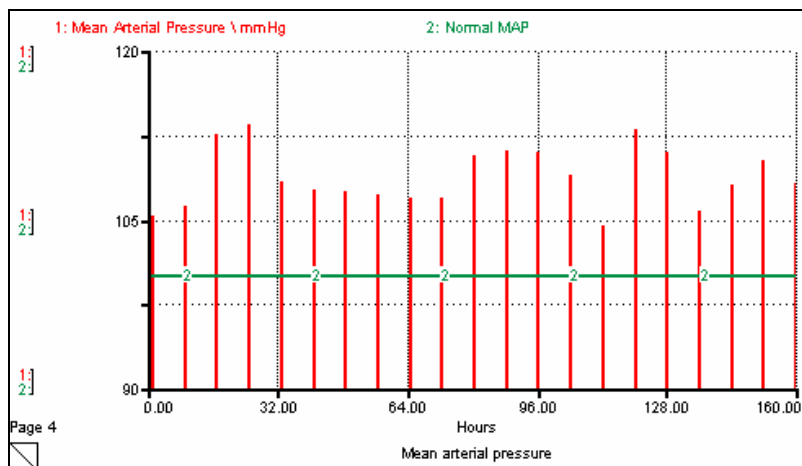

Figure 9.34. Dynamics of mean arterial pressure for the representative player

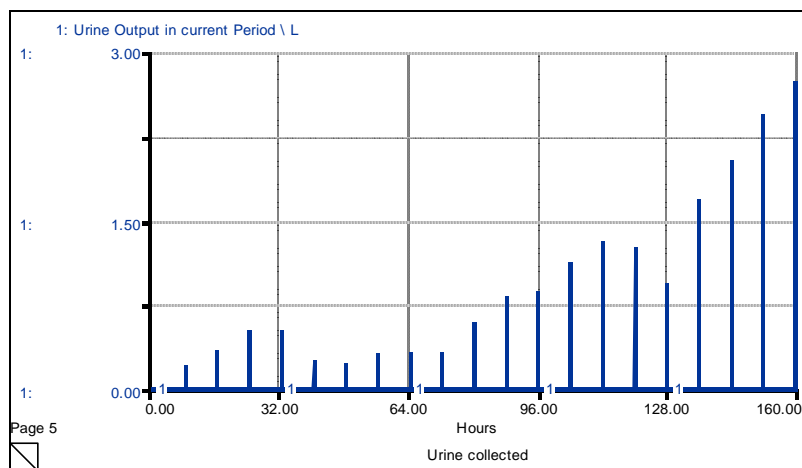

Figure 9.35. Dynamics of urine output for the representative player

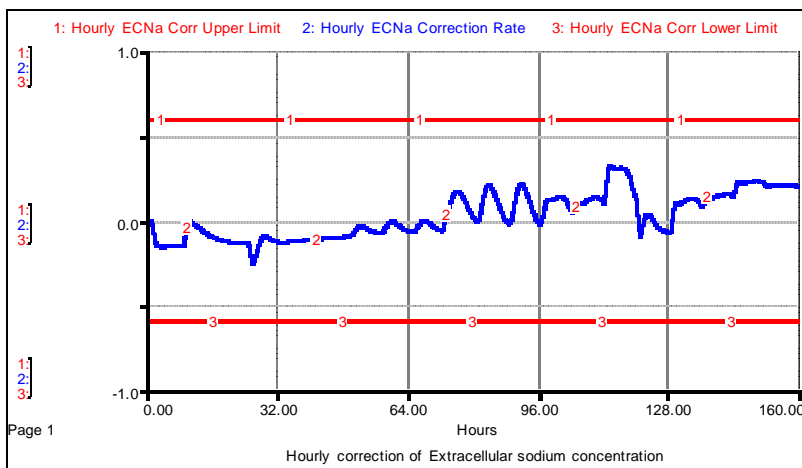

Figure 9.36. Dynamics of hourly ECNa correction rate for the representative player

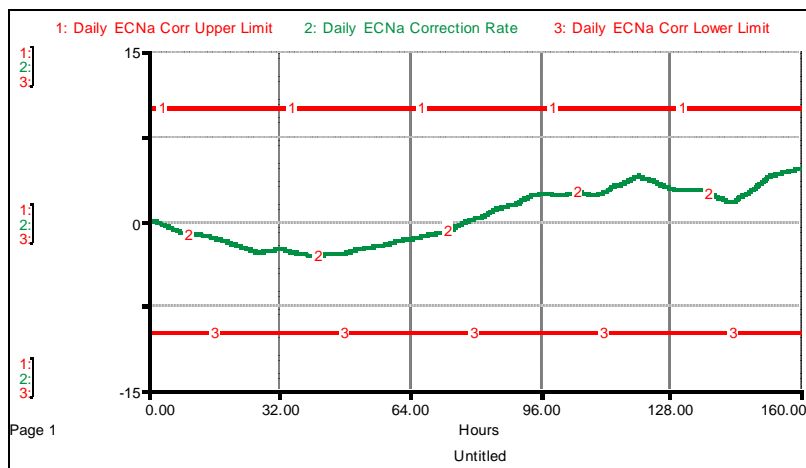

Figure 9.37. Dynamics of daily ECNa correction rate for the representative player

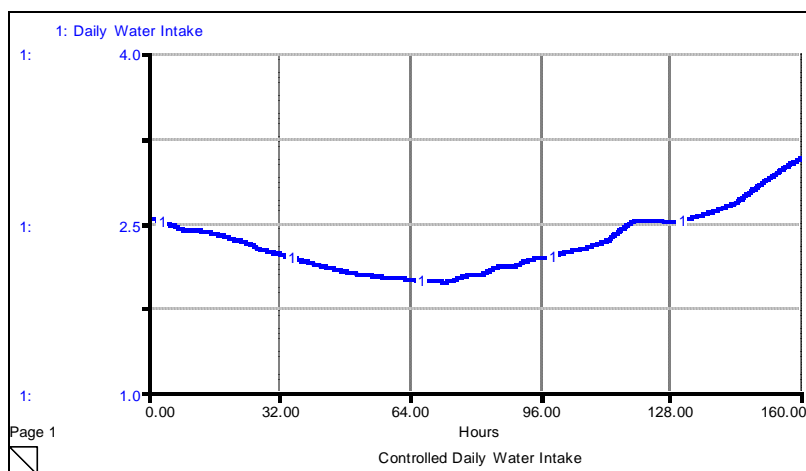

Figure 9.38. Dynamics of patient's daily water intake for the representative player

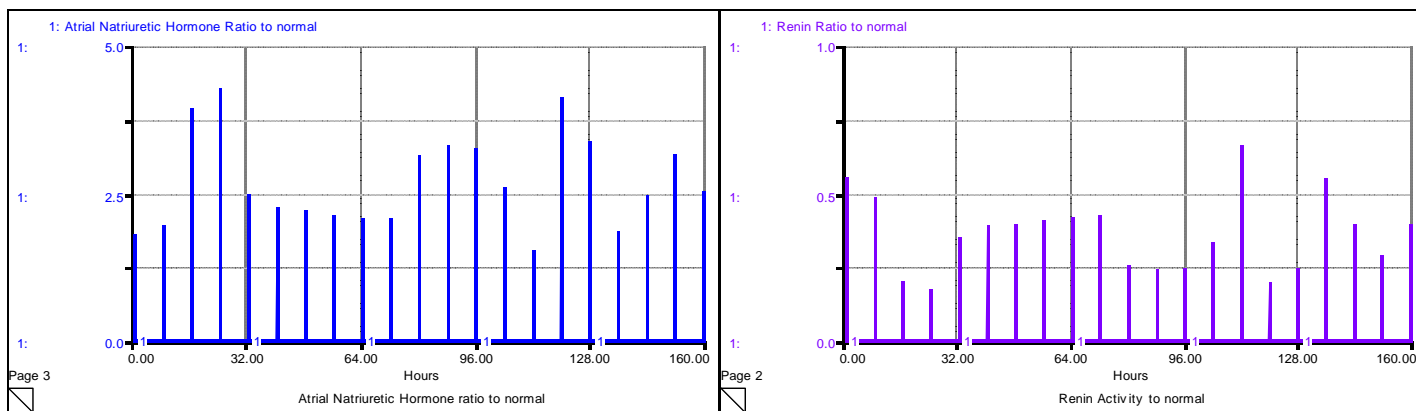

Figure 9.39. ANH and Renin dynamics for the representative player

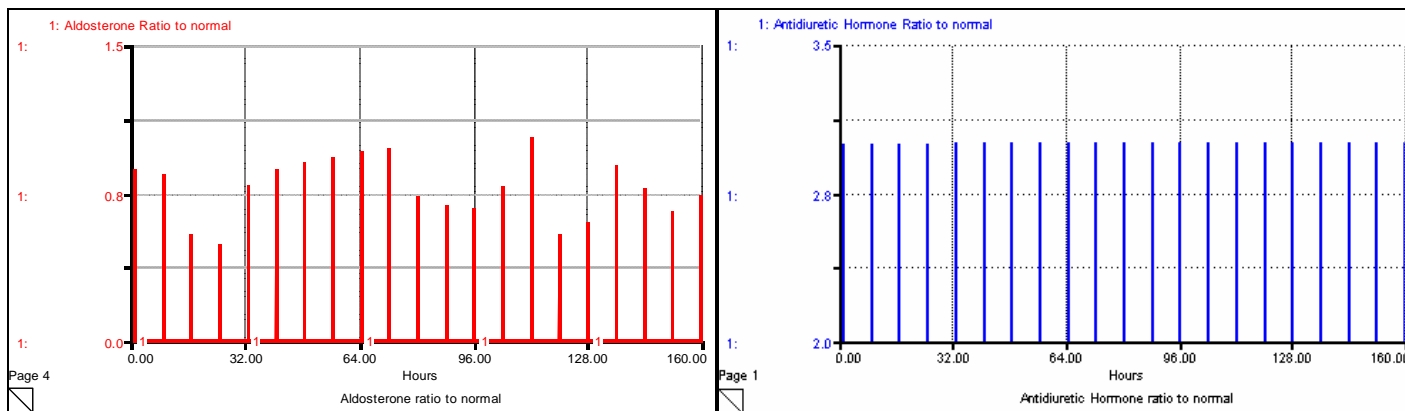

Figure 9.40. ALD and ADH dynamics for the representative player

There is no single correct set of decision for players, but they should take into account certain critical measures during their trials. As mentioned before, the ECNa correction rate is a vital concern while correcting the hyponatremia of the patient. The two goals of the treatment should be considered concurrently: attaining a negative water balance and replenishment of the sodium deficits. Diuretics may be useful in correcting the excess body water, however this treatment strategy should be supported by considerably high amounts of sodium, since diuretics cause sodium loss and hence decrease the already low sodium stores of the EC compartment. Therefore the players that used Diuretics instead of Aquaretics had to administer high amounts of saline.

On the other hand, Aquaretics may decrease the UNa concentration to levels below its normal; however Diuretics can only blunt the urinary concentration process, so they can decrease the UNa concentration at most to its normal level. If the patient has a UNa concentration lower than normal, it is not wise to administer Diuretics, since this would cause retention of water. Generally players administered Diuretics and Aquaretics together, and thus Diuretics reduced the effects of Aquaretics in these trials. This demonstrates that Diuretics should not be administered in severe cases of hyponatremia.

Another important point to note is the EC sodium level of the patient. In reality, the ECNa content cannot be measured directly as in the game, but the amount of sodium excreted and the arterial pressure may be used as indicators for the amount of sodium in the EC compartment, and the EC compartment volume. Since the sodium preserving systems are intact in an SIADH patient, the ECNa content is preserved at a lower steady state value via the feedback mechanisms of the body. However a wrong strategy which may cause sodium depletion may worsen the condition of the patient, both due to decreased sodium, and due to decreased urine flow. Normally, SIADH patients have a normal or slightly elevated MAP level, and this level should be closely monitored. Low MAP levels may inhibit the urine flow increasing strategies, and a very high level of MAP is also unwanted due to its negative consequences.

We now focus on a comparative evaluation of some key performance measures for the players. Figure 9.39 displays the ECNa concentration with respect to the corresponding trials of these five players. Player 1 first decreased and then slowly increased the ECNa concentration. Player 4 did not change the ECNa concentration noticeably, and player 3 decreased it. The trials of players 2 and 5 were the most successful ones; Player 5 continuously increased the ECNa concentration, however player 2 could not sustain the elevated level towards the end of the game. All the players were able to decrease the UNa concentration to some degree using the given drugs (See Figure 9.44).

In general, the total body water shows a variable decreasing trend for the 5 players as can be seen from the graph in Figure 9.40, except player 3. Figure 9.43 depicts that the MAP levels for the players stay close to normal levels, except players 1 and 3. Player 3 had fluctuating high levels of MAP. On the other hand, player 1 had the highest levels of MAP during his trial, and also he ended with the second lowest level of ECNa concentration at the end of the game.

Figures 9.41 and 9.42 display the hourly and the daily correction rates of the ECNa concentration. As can be seen from the graphs, all the players acted patiently throughout their simulation except player 3. Players 1 and 3 occasionally had correction rate levels below 0 for both hourly and daily correction.

Figure 9.45 displays the sodium intake decisions of the players. Among the two successful players, player 2 used a constant high amount of hypertonic saline, whereas player 5 used graded amounts of saline. However it is seen that the amount of sodium lost is consistently high for the 2nd player. On the other hand it stays at low levels for player 5 and does not increase further with increasing sodium intake towards the end of simulation. Since player 3 administered a high amount of isotonic saline on the 76th hour, both the sodium and the water intake (and hence the ECNa and the body water) increased abruptly and simulation stopped due to coma or death resulting from exceeding of the hourly correction limits.

Figure 9.47 depicts the total water intake levels resulting from drinking and saline infusion for each player. It is seen that water intake levels tend to increase in general. Among the two successful players, water intake for player 5 is the lowest, whereas the water intake for the player 2 is consistently high during the simulation. This indicates that player 5 accomplished to increase the ECNa concentration to almost same levels by administering less amounts of sodium.

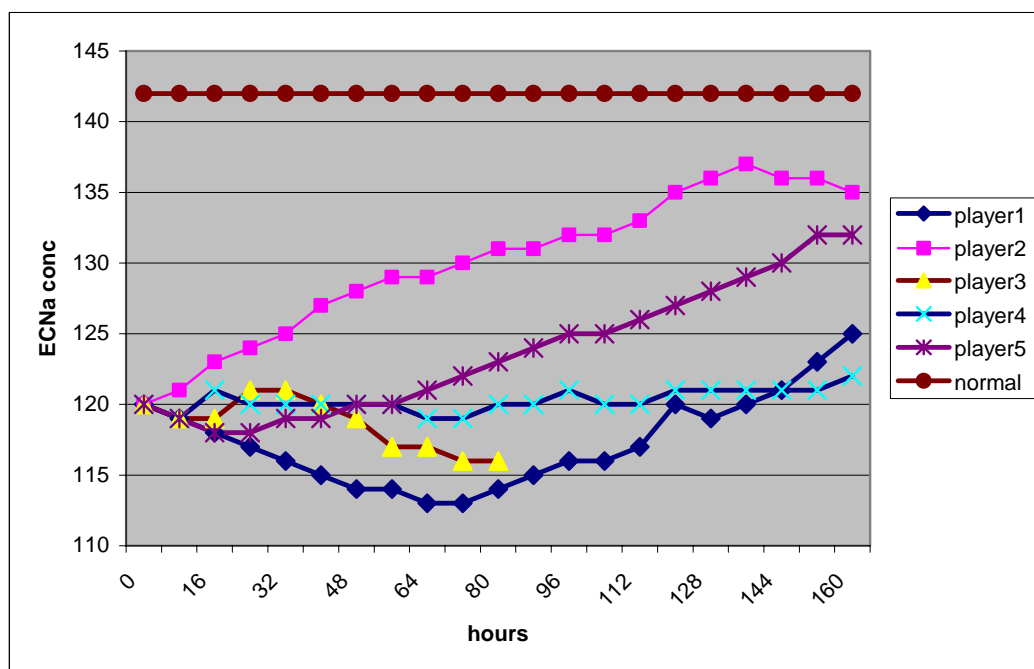

Figure 9.410. Dynamics of the ECNa concentration for five players

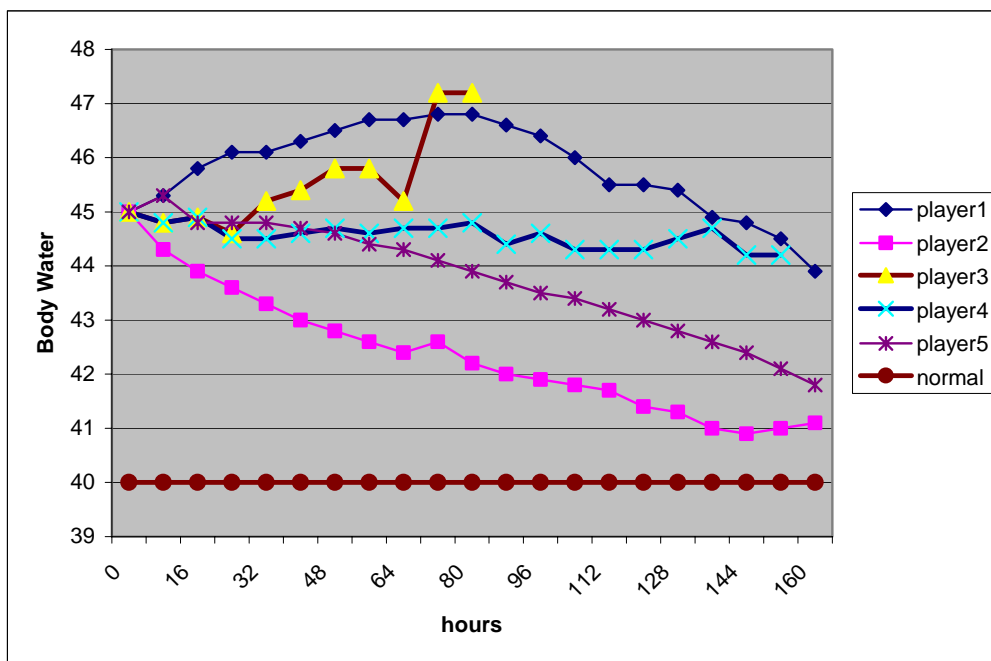

Figure 9.42. Dynamics of the total body water for five players

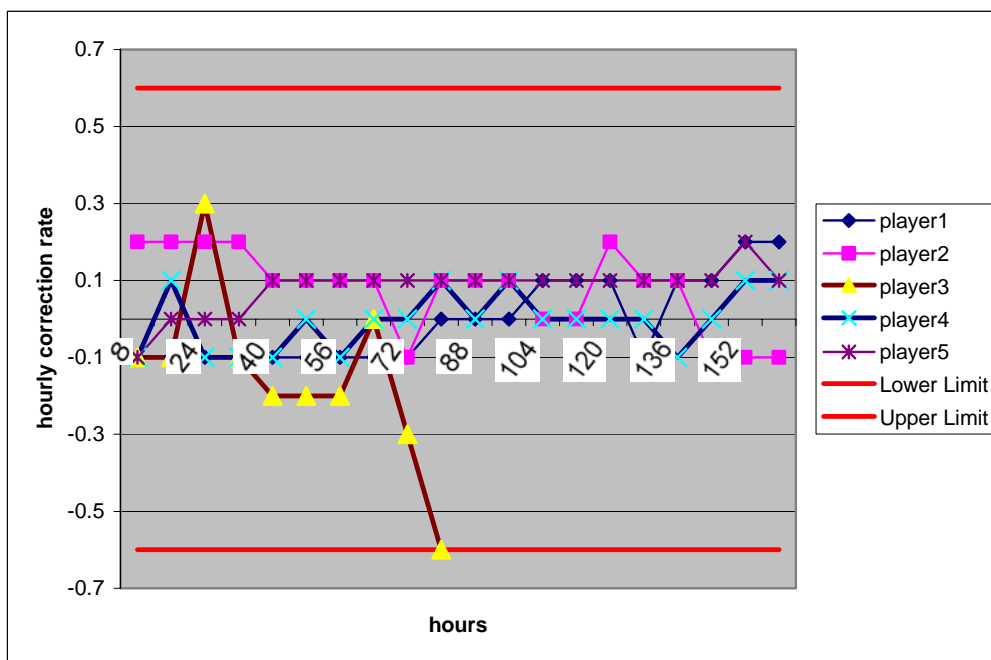

Figure 9.43. Dynamics of the hourly ECNa correction rate for five players

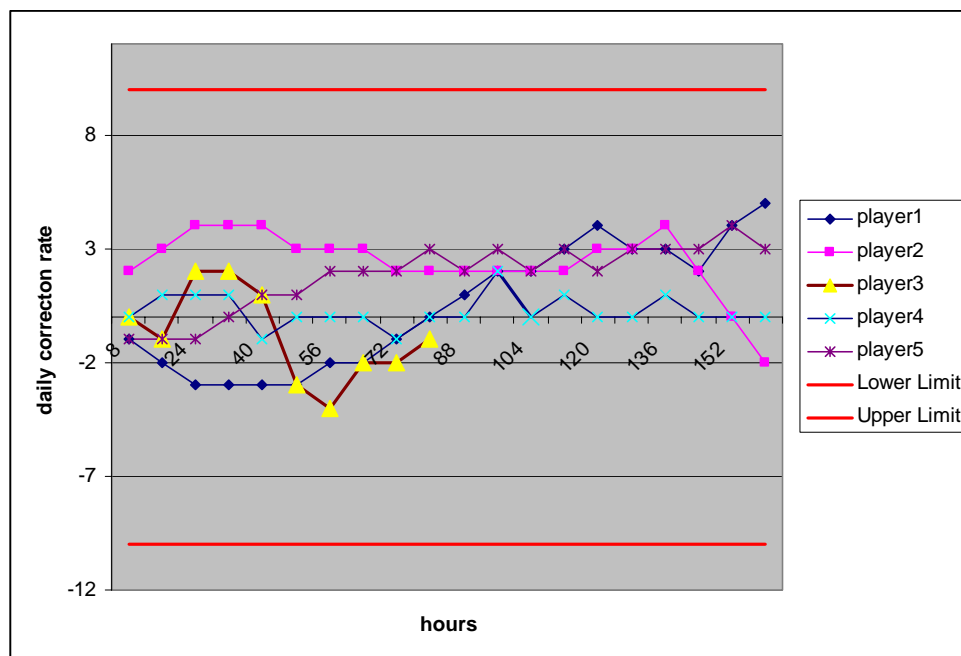

Figure 9.44. Dynamics of the daily ECNa correction rate for five players

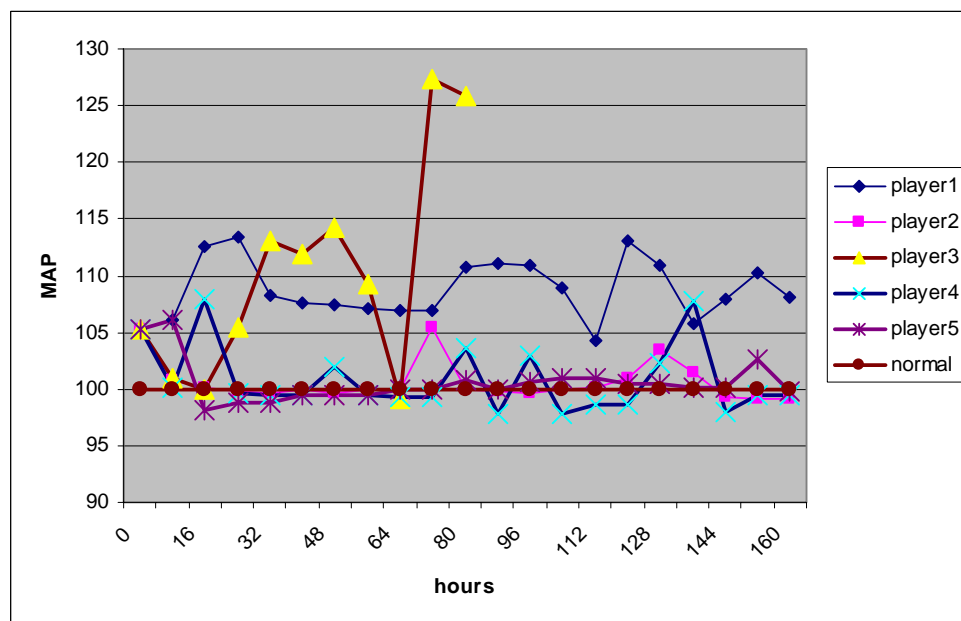

Figure 9.45. Dynamics of the mean arterial pressure for five players

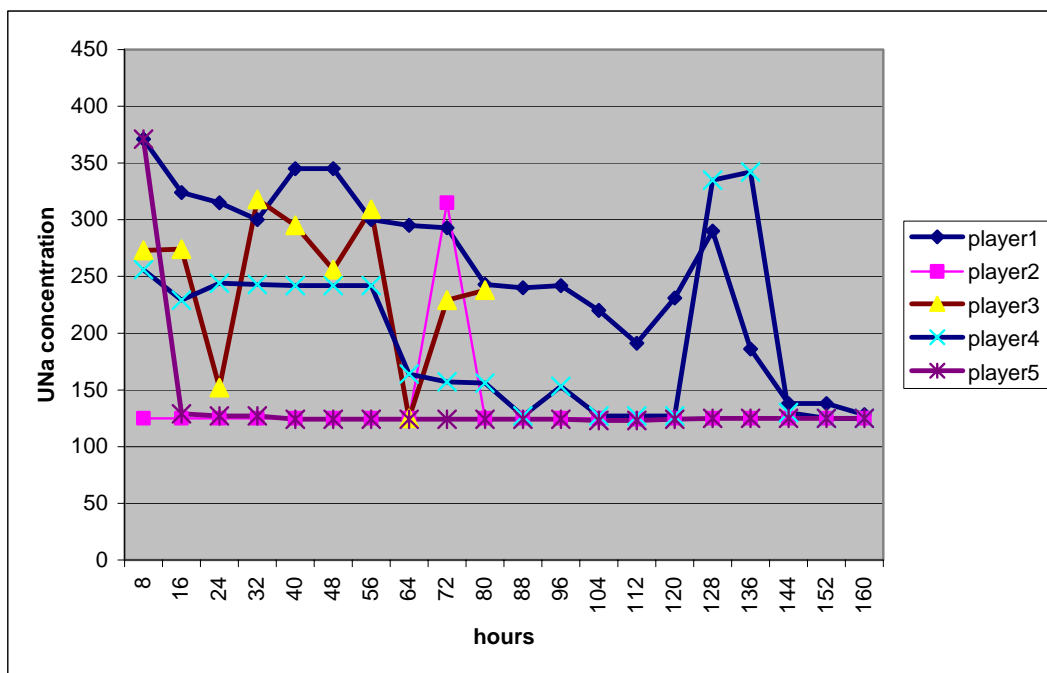

Figure 9.46. Dynamics of the UNa concentration resulting from decisions for five players

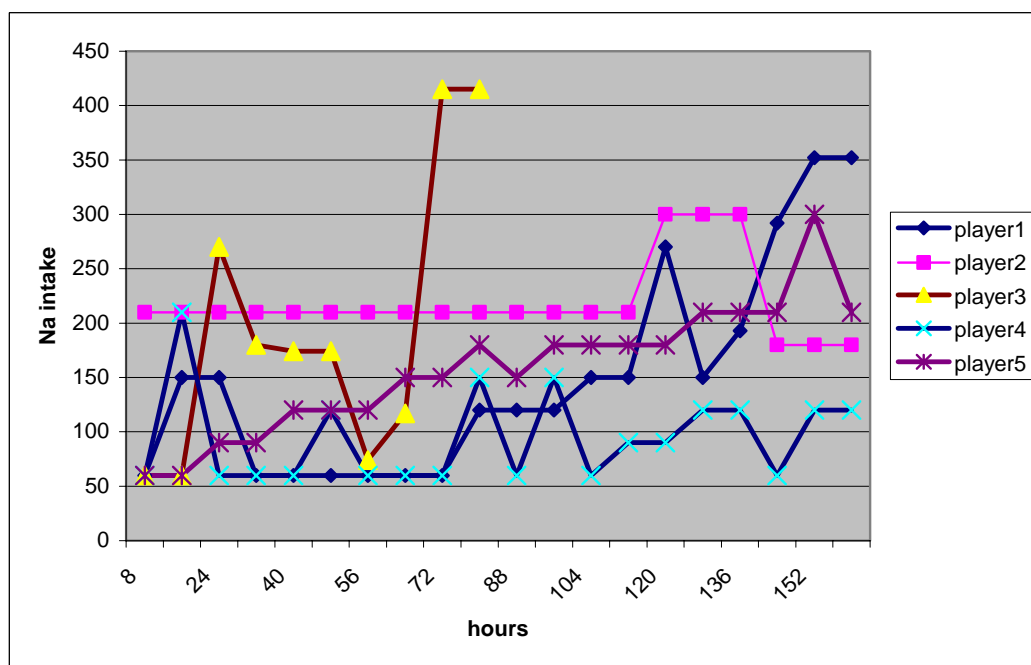

Figure 9.47. Sodium intakes resulting from decisions of five players

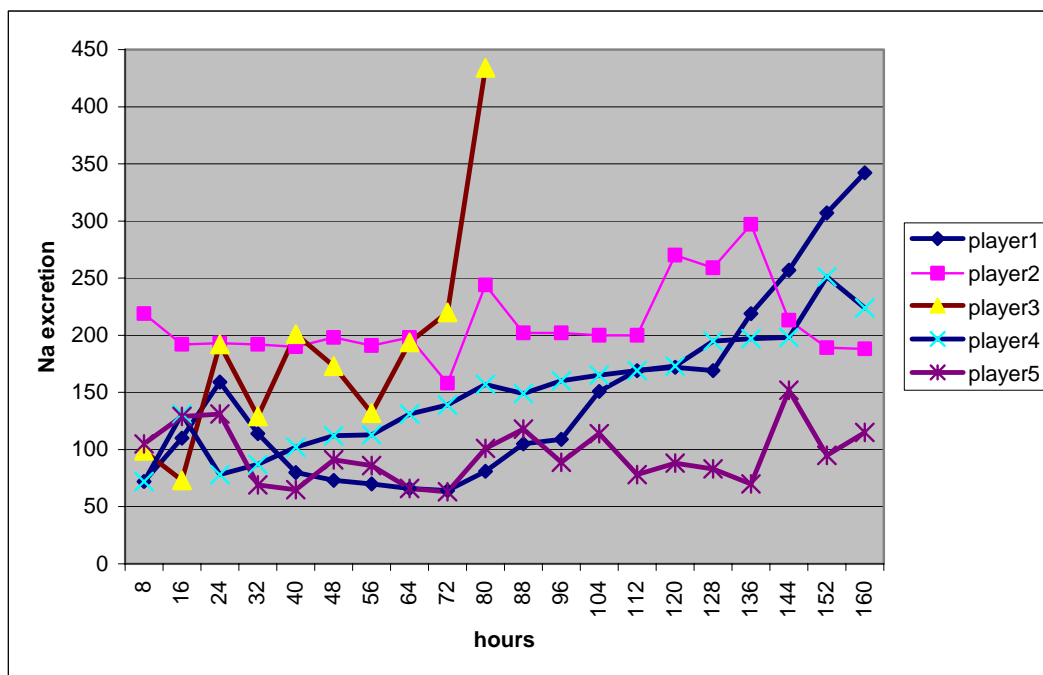

Figure 9.48. Dynamics of the sodium excretion rate for five players

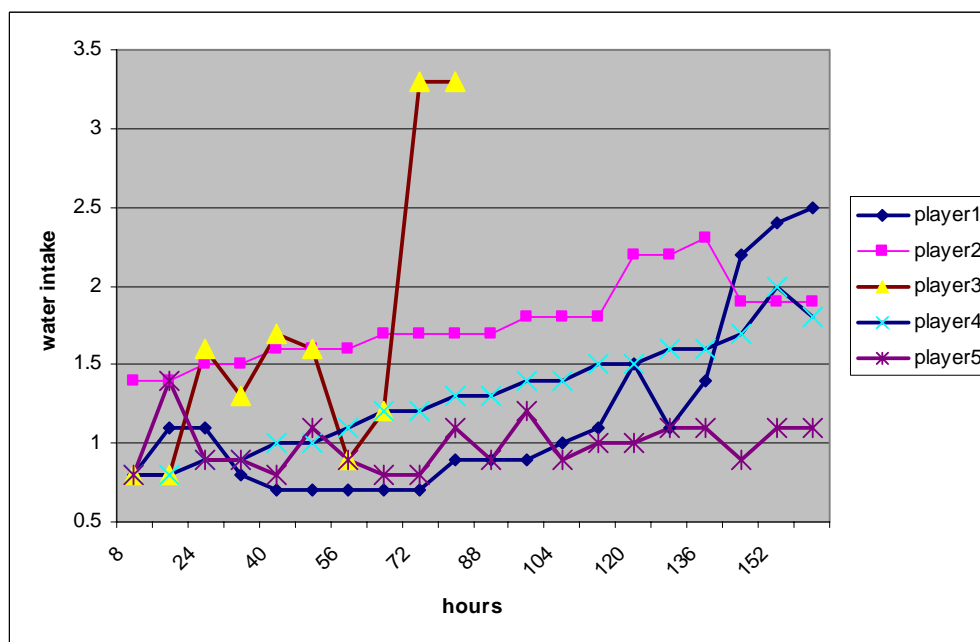

Figure 9.49. Dynamics of the total water intake for five players

10. CONCLUSIONS AND FURTHER RESEARCH

The purpose of this research is to study the normal and disease physiology of the body water metabolism, and to develop an interactive simulation model for a particular body fluid disorder, namely water intoxication/hyponatremia. For this purpose, a system dynamics model is built representing the structure of the body water and sodium balance for a normal individual. Then, this model is modified to include the effects of disease processes, and example dynamics are reproduced for the development of ADH-induced hyponatremia. Finally, a game version of the modified model is constructed by including the most relevant treatment options, and possible necessary measurements for diagnosis. The game is then used as an experiment platform to test and compare the possible effects of a given set of treatment options on a simulated patient. This interactive simulation game attempts to be a step towards a closed-loop therapy for the hyponatremia patients. It can also be used as a learning and teaching environment for the renal physiology, and especially for the differentiation between the concepts of “sodium content” and “sodium concentration”, and related disorders.

The normal physiology of the body water metabolism entails an understanding of two distinct but interactive homeostatic systems: the systems that regulate the extracellular sodium concentration/body water content and the systems that regulate the blood volume/sodium content. The mechanism for the regulation of water balance is often referred to as the ‘thirst-ADH mechanism’. This system regulates water intake by controlling the perception of thirst, and water output by ADH, which is responsible for the urinary concentration and dilution. On the other hand, the main feedback mechanisms for sodium balance include the ALD, the ANH, and the renal mechanisms.

As a result of extensive validity testing, the model is found to be a robust representation of the water-electrolyte balance in normal and various test conditions. The model demonstrates that ADH is extremely important for the control of sodium concentration, yet it has a relatively mild effect on the control of blood volume/pressure. On the other hand, arterial pressure is mainly determined by “sodium intake”, rather than water

intake, which at first seems paradoxical, since arterial pressure is in fact determined by the “water volume” of the extracellular compartment. The study also depicts that excessive secretion of either ADH or ALD does not increase body fluid volumes infinitely, since the effects known as ‘ADH escape’ and ‘ALD escape’ protect the body from retention of high levels of water. The compensating mechanisms for escape mainly change the sodium excretion rate or the urinary concentration in the absence/excess of these hormones, so as to return the body fluid balance to its normal. Therefore it can be concluded that conserving the body fluid balance is a preliminary to conserve a constant blood pressure or a constant blood sodium concentration.

The modified model for the development of hyponatremia reproduces all the cardinal features of the SIADH. As in the reality, dysregulated ADH-thirst system first causes an increase in the body fluids, but when the part retained in the extracellular fluid is sufficient to activate volume receptors, transient sodium loss is promoted, and the extracellular volume is only slightly elevated, despite the apparent expansion of the total body water. Hence, it is the intracellular compartment which is mostly expanded in SIADH. As a result of dilution, extracellular sodium concentration falls drastically. The arterial pressure is also slightly elevated, and this causes an increase in the glomerular filtration rate. Moreover, urine is still highly concentrated due to the absent negative feedback between the extracellular sodium concentration and the ADH.

The interactive simulation game version yields meaningful results for various treatment options. Game results reveal that the effective correction of the SIADH can only be attained if a negative water balance can be maintained. Replacing the sodium deficits alone is worthless since blood volume/pressure conserving mechanisms cause an increased sodium excretion rate following the intake. Moreover, it is demonstrated that graded doses of hypertonic saline infusion is the most useful solution for the treatment. However it should be administered carefully to prevent an overcorrection, and concurrently with drugs that increase the urine flow. It is also depicted that ADH-Antagonists are superior over diuretics in SIADH in preventing intracellular edema. However diuretics could be used as an adjunct to Aquaretics in certain edema forming conditions, since a sodium diuresis is

desirable in these conditions. In conclusion, the model and the game version constitute an experimental laboratory for a closed-loop therapy approach to hyponatremia.

There are several avenues in which this research can be expanded. One first step is converting the current game model for the treatment of severe hyponatremia in an intensive care unit setting, by changing the initial conditions of the modified model and the treatment options. Moreover, more realistic initial conditions could be selected to represent a person who is inclined to become hyponatremic. Drinking structure of the model could also be modified to be more realistic about the normal physiology. As mentioned before, short term drinking feedbacks exist, e.g. the gastric feedback which prevents an overly high water intake in a short time period.

Since the focus of the modified model is the development and therapy of hyponatremia, other electrolytes have not been analyzed. The model can be extended to incorporate potassium dynamics, since sodium and potassium regulatory systems are coupled with the levels of aldosterone. In fact, hyponatremia occurs with many other electrolyte imbalances, and hypokalemia (low levels of extracellular potassium concentration) is the most common electrolyte disorder. Under normal conditions the extracellular potassium dynamics is tightly controlled, since changes in the potassium concentration have an important influence on cellular hydration, and most significantly in the heart as a cause of cardiac arrest (Northrop, 2000). Moreover, pharmacological means to correct hyponatremia often have a reverse effect on the potassium metabolism. For instance, diuretics are known also to increase the potassium excretion, along with many other electrolytes. An analysis of impacts of the treatment options of hyponatremia on potassium dynamics may reveal a broader range of possible physiological phenomena.

Another important electrolyte excluded from this study is the urea. We have assumed that urine osmolality is only determined by the sodium chloride; however in reality urea also contributes to 40 percent of the urine osmolality when the kidney is forming a maximally concentrated urine (Guyton, 2000). In SIADH, plasma urea concentration is unusually low due to the excess body water and the rise in the glomerular filtration.

Moreover, urea is also used for the therapy of SIADH, and it is demonstrated that oral urea is efficient in producing a high osmotic diuresis in patients with the SIADH (Decaux, 1981).

The rate of solute excretion is another determinant of the final urine osmolality. The kidney can play with the concentration of urine at relatively low rates of solute excretion, i.e. it can concentrate or dilute urine maximally. However at greater rates of solute excretion, the ability of the kidney to modify the final osmolality of urine becomes progressively blunted. Stated in another way, as solute excretion rate increases, the osmolality of either a hypotonic or a hypertonic urine approaches that of plasma, regardless of the circulating ADH level. This property allows for instance urea to be a safe and effective treatment of the SIADH.

APPENDIX A: USER GUIDE OF BWATERGAME

The Game for Body Water Disorder Therapy (BWaterGame) is an interactive dynamic simulator for medical management of a disturbance in salt and water balance, namely water intoxication or hyponatremia, which can be defined as a reduced level of Extracellular Sodium concentration (**ECNa_conc.**)

The regulation of water balance is important in almost every area of medicine. Pathologic conditions associated with water metabolism are generally manifest by disturbances in extracellular sodium concentration (dysnatremias). These disorders relate to deficiencies or excessive secretion of Antidiuretic Hormone (**ADH**), whose primary function is to control the Extracellular Sodium Concentration (**ECNa_conc**) by varying the urine flow rate and urine osmolality.

The underlying model of the simulation game is developed using System Dynamics methodology. The player plays the part of a physician, who is trying to treat a hyponatremic patient with an ECNa conc. of 120 mEq/L and an excess body water of about 5 lt. Please note that the “normal” level of plasma sodium is 142 mEq/L. While hyponatremia is defined as an ECNa conc less than 135 mmol/l, clinical symptoms are seldom seen when the serum sodium is greater than 125 mmol/l and are generally seen with a sodium less than 120 mmol/l. At values below 110 mmol/l, patients frequently die sudden deaths because of coma and convulsions.

The primary goal is to increase and sustain the Extracellular Sodium Concentration (ECNa_conc.) to its normal levels, which is about 140 mEq/L. At the same time, the total body water content should be decreased to its normal value of 40 liters as well as the extracellular & the intracellular water volumes. The challenge is to achieve these goals in balance, since rapid correction of severe hyponatremia can cause brain demyelination (brain edema and subsequent neurologic consequences), which may produce neurological morbidity and mortality.

The player should seek a delicate balance among weighing the risks of hyponatremia itself and those associated with rapid correction of hyponatremia. A low *ECNa_conc.* is associated with an increasing rate of mortality. Depending on the degree of water retention, weakness and muscle cramps may develop, followed by confusion (“water intoxication”), convulsions, coma and death. On the other hand, irreversible neurological damage and death may also occur when the *ECNa conc.* is rapidly corrected.

Excessive or inappropriate production of ADH- Syndrome of Inappropriate ADH secretion (SIADH), predisposes to hyponatremia, reflecting water retention. SIADH is the prototypical disorder for hyponatremia. The patient in the game has water retention and consequently severe hyponatremia due to SIADH of unknown reason. Cardinal features of the SIADH are: Hyponatremia, urine osmolality greater than plasma osmolality, excessive renal sodium excretion, absence of hypotension, hypovolemia, and edema-forming states.

The diagnosis and treatment of hyponatremia is also often challenging and can add to the problem if inappropriately managed, since many and sometimes complex factors influence the *ECNa conc.* One should always keep in mind that the system that regulates total body water and *ECNa conc.* is a multiple input/multiple output system and is cross-coupled with systems that regulate the mean arterial pressure (**MAP**).

Player Decisions

To date physicians have two main options in treating hyponatremia: a) They can try to limit fluid intake, and b) they can reduce ADH or its effect in the kidney. When the primary cause of the disorder cannot be treated, water restriction is the present mainstay of treatment. Compliance with water restriction is poor, however; because it is impractical, inefficient and difficult for the physician and the patient alike. Therefore water restriction is presented only as an option in the scenario settings of the game.

The decisions made by the player can be of two types: The player may choose to give the patient a drug, namely a “diuretic” and/or an “ADH Antagonist” (also known as

Aquaretics) to the patient. The main effect of these drugs is to change the urinary concentration; however they may have side effects which will be explained below.

Fluid therapy (or saline infusion) constitutes another important part of the current standard therapy for treating hyponatremia. It simply means to give water to the patient with different concentrations of sodium. Since various types of intravenous fluids exist; the three most commonly used categories are presented in the model, namely hypertonic, isotonic, and hypotonic fluids, which are classified according to their sodium content. Though fluid therapy is an important and quite ordinary therapeutic means, many problems are still associated with it.

(A) Dose Diuretic: Diuretics are occasionally used in hyponatremic patients to block the ability of ADH to concentrate the urine at high ADH levels. You should note that this drug prevents formation of a concentrated urine and “lowers” the urine osmolality only when the urine is more concentrated than normal. Moreover, diuretics have well known side-effects: They cause significant urinary losses of sodium, potassium, and magnesium. In this model, only sodium and potassium ions are presented and the level of potassium ions is taken as constant. The player decides the dose given to the patient orally or intravenously (directly to the bloodstream). The effect of diuretics occurs in a dose-dependent manner.

(B) Dose ADH Antagonist: Antidiuretic Hormone Antagonists (also known as Aquaretics) are another category of drugs which can be used in the management of patients with water excess and consequent dilutional hyponatremia, as in patients with congestive heart failure and cirrhosis, or in patients with euvolemic hyponatremia, as in patients with Syndrome of Inappropriate Antidiuretic Hormone (SIADH). These agents have been termed “aquaretics” because of their ability to increase urine flow rate without affecting sodium excretion. However it is seen that at higher doses they increase the current plasma ADH levels also, which is a complication related to their usage. The player decides the dose given to the patient orally or intravenously. Since their effect occurs in a dose-dependent manner like diuretics, one should pay attention not to cause dehydration while trying to increase the urine flow.

(C) Isotonic (or Normal) Saline: This **solution** has an $[Na^+]$ conc. similar to that of the normal plasma.

(D) Hypotonic Saline: Hypotonic solutions vary between 0.45% and 0,18 % saline (77 and 30 mEq/L Na). They have an **osmolality** smaller than the “normal” plasma osmolality. Hypotonic solutions are considered less dangerous in fluid therapy in general.

(E) Hypertonic Saline: Hypertonic saline 3% has an osmolality three times that of plasma. You should note that the percentage **of** sodium included in hypertonic saline is biggest, but if given, one should consider that it also carries the biggest risk of causing an overcorrection rate if used in inappropriately high amounts.

Starting the Game

The user must have Stella® Research Version 5.1 or later installed in his computer in order to play the game. The game can be started by double clicking the “BWaterGame” icon

Logical Flow of the Game

The game is designed as a series of screens, which are connected to each other. The opening screen displays the title of the game and the main menu items, which are listed as follows:

- (A) Background
- (B) Game
- (C) Explore Model
- (D) Quit Game

Running a New Game

After the “Experiment” button is pressed the main game screen appears. In the top left corner of the screen are two information buttons, which let the player to reach brief instructions about the game and the decisions during the game when they are pressed.

On the bottom right corner of the screen, the game controls are displayed. The game is initiated by pressing the Reset and Start buttons in the New Game that is displayed at the bottom right corner of the screen.

On the left side of the screen, the Decision Sliders are displayed. After the decisions are made, the **Advance** button should be pressed. When this button is pressed the simulation advances 8 hours (which is the default value and can be changed in the scenario settings) and the new values of the variables are calculated. The simulation will pause automatically every 8 hour to let the player change his decision settings and review data. Pressing the **Record of Decisions** button on the top of the screen enables the player to examine the history of the decisions in a graphical and tabular format and pressing the **Graph** buttons in the Body Water and Body Sodium frames enables the player to review the related body water and sodium indicators measured between the periods.

Once a decision value is changed from its original value, a “U” appears at the bottom-left corner of the slider. Clicking on it will reset the value to sliders’ original value. Clicking on the “?” buttons on the sliders enables the player to reach more information about the associated decision variable.

The total duration will be 160 hours, or 20 decision rounds. At the beginning of the game, you can increase the decision period (or the pause interval) of the simulation from its default value of 8 hours to 4 or 12 hours. The simulation time can be traced through the displays that are located on the top right corner of the screen. At any time, the player can quit the simulation by pressing the **End Game** button that is displayed at the bottom right corner of the screen.

To start a new game the player should first terminate the current game pressing the End Game button. Next, the model should be initialized to its original setting pressing the **Reset** button in the **New Game** frame. Then a new game can be started pressing the Start button in the same frame. Between two sequential games the model must be “Reset” first! Otherwise the Start button would not work properly.

On the middle of the screen, the main indicators (variables related to body water and sodium, hormonal indicators and other measures) are displayed in order to give the player feedback about the major variables. Pressing the “Graph” buttons on the right or bottom of these variables, the dynamic behavior pattern of that variable can be displayed. On the right side of the screen, three main indicators are displayed as warning devices, for which three distinct zones are set - normal, caution, danger. As the value of the variable passes through these zones, the warning device displays the color associated with that zone – green, yellow and red, respectively. Pressing the “?” buttons on the right of the variables, brief descriptions of those variables can be displayed.

Analysis of the Model

Clicking the **Explore Model** button displayed in the Main Menu screen will take the player to the Model Overview Screen. The purpose of this screen is to give the player information about the interactions between the variables in the model. This is a high-level overview of the model, which shows the sectors in the system and the physical (thick arrows) flows between them.

Clicking on the lower portion of the corresponding sector frame takes the player to the modeling layer and enables him to trace out the model for a particular sector one at a time. Clicking on the dots would reveal the model structure. To return back to the high-level map, the upward-pointing triangle in the left-hand margin of the window should be clicked.

The whole sector at a snapshot can be viewed by clicking the downward pointing triangle at the top right corner of the sector frame. The player can return to the high-level

map by pressing the Back buttons, which are displayed on the modeling layer. The **Control Panel** button on the bottom of the screen takes the player back to the main game screen.

It is recommended that you first take a tour in the model before starting, since you can find more explanation about the variables in the model.

Information about the Model

Clicking on the **Background** button in the opening / main menu screen takes the player to the “General Information about the Model”. The purpose of this screen is to give the player brief information about the model, hints and warnings.

Information about the Controls

Clicking on the **About Controls** button in the Control Panel takes the player to the “General Information about Input Sliders” Screen. The purpose of this screen is to give the player general information about the use of the sliders.

Quit

Clicking on the Quit button initiates quitting process. Before exiting the game, you are asked to save the game results in a file. If you don't save your game results you lose them. If you choose to save them you are asked to enter a name for the file, which will keep the data of the current game results. It must have the extension “.stm” in Windows environment.

Advanced Gaming

Clicking on the Vary Scenario button displayed on the bottom of the screen takes the player to the screen where the drug effects, the decision period setting and the water intake decision are listed. Varying these variables in different combinations lets the player to play the game under different drug types corresponding to the same category. A “mild” or “severe” water restriction could also be imposed to the patient between runs. If you don’t change it, the default scenario is “unrestricted” water intake. At the beginning of the game, you can increase your decision period (or the pause interval of the simulation) from its default value of 8 hours to 4 or 12 hours.

To change some predefined relations you should click one of the graphical functions and change the shape of the function. If you change a graphical function, a small "U" button appears in the lower left corner. To restore the function to its original shape, you should click once the "U" button. If you need more information, you should click once on the question mark (?) button at the bottom. Clicking once on the question mark button at the bottom of the knob enables the player to reach more information about the associated function.

These conditions can not be changed during the game but “Varying the Scenario Screen” can be visited to check what the conditions are.

Hints and Warnings

The values in decision sliders are set at zero at the beginning of the game. To adjust the slider input devices, the player has simply move the slider to dose the patient. The slider will automatically reset itself after each decision period, except the saline infusion decision. The daily water intake decision does not change if you don't change it in the decision rounds. The player should revise his decisions at each step, by making use of the provided analysis tools.

Results will be displayed in the graphs. You will also receive periodic messages from the patient and your peers.

Please keep in mind that the amount of saline decided to be given to the patient will be infused during the decision period, e.g. if you decide to give 1000 ml of isotonic saline when your decision period is 8 hours, the amount of saline to be given during that 8 hour period is $1000/8$ ml per hour.

The Extracellular (**EC**) and Intracellular (**IC**) fluid osmolalities (**EC_{osm}** and **IC_{osm}**) are always identical. In the model it is assumed that the EC_{osm} is proportional at all times to EC sodium concentration, and IC_{osm} proportional to IC potassium conc. Amount of potassium is taken as constant, only sodium amount can be changed by purpose. Sodium and potassium are assumed to be locked in their respective compartments, and only water can cross the boundary to equalize the osmolalities. It is assumed that within the timescale of the model water is transferred between the EC and the IC pools instantaneously to ensure osmotic equilibrium.

The most important physiologic action of ADH is to influence the rate of urine flow by promoting concentration of urine. A change in ADH level immediately causes a change in urine flow and concentration. Note that the urine flow is automatically calculated as inversely proportional to urinary sodium concentration, so that a given amount of sodium excretion rate is conserved. The amount of sodium excretion is on the other hand determined by Aldosterone (ALD) and Atrial Natriuretic Hormone (ANH), and the filtered load of sodium (which is equal to the Glomerular Filtration Rate (GFR) \times ECNa_{conc}).

Excess secretion of ADH alone is not sufficient to produce hyponatremia; thirst has also to be dysregulated. Normally, thirst response has to decrease with decreasing ECNa_{Conc.} and increasing body water. However, for reasons not well understood, SIADH patients continue to drink and this, combined with high ADH levels, leads to hyponatremia.

The initial values of the game are as shown in the opening screen. The game starts with initial values of a severe hyponatremic patient.

The minimum and maximum limits for decisions per decision period are as follows:

Dose Diuretic Decision	mg: 0-750
Dose Aquaretic Decision	mg: 0-750
Isotonic Saline Decision	ml: 0-2500
Hypertonic Saline Decision	ml: 0-1500
Hypotonic Saline Decision:	ml: 0-2500

Finally, please keep in mind that there is no winning or losing in such systemic games! The purpose is not to be on some 'high scores' list, but to learn during the game. And for this purpose, the player should try to base his decisions on the information feedback displayed through the game. The expectation is that the player's understanding of the problem issues will gradually increase after playing the game many times.

APPENDIX B: LIST OF VARIABLES, DEFINITIONS, AND UNITS

B.1. Body Water Sector

Variables used in the body water sector are listed below;

Drink_Mode = A Discrete variable which takes the value of 1 when the patient drinks, otherwise it is 0 {dimensionless}

mode_on = Start of Drinking {dimensionless}

mode_off = End of Drinking {dimensionless}

Gut = Init_Gut {ml}

drinking = Rate of Drinking {ml/h}

gut_to_in = Water Transfer Rate from the Gut to the Interior of the Body {ml/h}

TBW = Total Body Water {ml}

water_infusion = Water Infusion Rate {ml/h}

urine_flow__ = Hourly Urine Flow Rate {ml/h}

continuous_drinking? = Switch Variable to decide whether to drink intermittently or continuously. It takes the value of 1 if drinking is continuous and 0 otherwise: {dimensionless}

Daily_Water_Intake = Daily Water Intake Rate {L/day}

discontinuous_drinking = Discontinuous Drinking Rate {ml/h}

disease_eff_of_ECOsm_on_drinking = diseased effect of Extracellular Osmolality on Drinking {dimensionless}

drinking_rate = Drinking Rate of the Patient {ml/h}

eff_of_EC_Osm_on_drinking = Effect of Extracellular Osmolality on Drinking {dimensionless}

Extracellular_Fluid_Vol = Total Extracellular Fluid Volume {L}

implied_UFlow = Implied Urine Flow Rate {ml/hr}

Intracellular_Fluid_Vol = Total Intracellular Fluid Volume {L}

key_off = Key-Off Variable {dimensionless}

key_off_2 = Switch Variable which takes the value of 1 if water sensed by body is bigger than the Upper Limit {dimensionless}
key_on = Key-On Variable {dimensionless}
key_on_2 = Switch Variable which takes the value of 1 if water sensed by body is bigger is smaller than the Lower Limit {dimensionless}
l_limit = Lower Limit of Drinking, or the condition that triggers drinking {ml}
mild = Daily Water Intake if mild Water restriction is imposed {ml}
mild_water_restriction = Switch Variable which takes the value of 1 if Mild Water Restriction is imposed on the patient. Otherwise it takes the value of 0: {dimensionless}
min_urine_flow_ = Obligatory Urine Volume {ml/h}
normal_drinking = Normal Hourly Water Intake {ml/h}
normal_UFlow = Normal Urine Flow {ml/min}
pct_change_hydration = Percent Change in Hydration {dimensionless}
plasma_fraction = Blood Fraction of Plasma {dimensionless}
Plasma_Volume = Plasma Volume {L}
severe = Daily Water Intake if Severe Water Restriction is imposed {ml}
severe_water_restriction = Switch Variable which takes the value of 1 if severe water restriction is imposed on the patient. Otherwise it takes the value of 0: {dimensionless}
time_to_reach_body = Time Constant for Water to be Transferred from the Gut to the Interior of the Body {h}
Total_Body_Water = Total Body Water in liters {L}
unrestricted_drinking = Normal Drinking Response of the patient if not restraint by the doctor {ml/h}
unrestricted_intake = Switch Variable which takes the value of 1 if no water restriction is imposed on the patient. Otherwise it takes the value of 0 {dimensionless}
u_limit = Upper Limit of the Total Body Water Level where Drinking Ends {ml}
water_lost = Total Urinary and Insensible Loss {ml/h}
water_sensed_by_body = Total Body Water that is Sensed by the Body {ml}
BV = Blood Volume {L}
eff_of_high_osm_on_drinking = Effect of High Extracellular Sodium Concentration on Drinking {dimensionless}
eff_of_low_osm_on_drinking = Effect of Low Extracellular Sodium Concentration on Drinking {dimensionless}

Glomerular_Filtr_Rate = Glomerular Filtration Rate {ml/min}

Mean_Arter_Press = Mean Arterial Pressure {mmHg}

B.2. Sodium Sector

Variables used in the sodium sector are listed below;

Extracellular_Na = Total Extracellular Sodium {in mEq}

na_intake = Sodium Intake Rate {mEq/h}

na_infusion = Sodium Infused {mEq/h}

na_out_in_urine = Sodium Excreted via the Urine {mEq/h}

ExtracellularNa_conc = Extracellular Sodium Concentration {mEq/L}

ECOsm = Extracellular Osmolality {mEq/L}

Filtered_Na = Filtered Load of Sodium {mEq/min}

IK = Intracellular Potassium {mEq}

IK conc = Intracellular Potassium Concentration {mEq/L}

log_ALD_ratio = Logarithm of Aldosterone Ratio to Normal {dimensionless}

na_excr_ratio = Sodium Excretion in Urine with Reference to its Normal Value {dimensionless}

na_intake_times = Sodium intake ratio to its reference value {dimensionless}

na_out = {mEq/min}

normal_fract = Normal Fraction of Sodium Excreted {dimensionless}

normal_na_excr = Normal Hourly Sodium Excretion {mEq/hr}

normal_na_intake = Normal Sodium Intake {mEq/h}

pct_ch_ECOsm = Percent change in Extracellular Osmolality {dimensionless}

set_point_ECOsm = Set-point of the Extracellular Osmolality {mEq/ml}

eff_of_ALD_on_na_excr = Effect of Aldosterone on Sodium Excretion Rate {dimensionless}

eff_of_ANH_on_na_excr = Effect of Atrial Natriuretic Hormone on Sodium Excretion Rate {dimensionless}

B.3. Endocrine System Sector Group

Variables used in the Antidiuretic Hormone (ADH), Renin-Angiotensin-Aldosterone System (RAAS) and the Atrial Natriuretic Hormone (ANH) subsectors are listed below;

ADH_in_plasma = Amount of Antidiuretic hormone in plasma {pg}
actual_ADH_release = Actual release of ADH from the pool {pg/h}
ADH_clear = Antidiuretic hormone clearance {pg/h}
ADH_Pool = Amount of ADH in the pool {pg}
ADH_production = ADH production rate {pg/h}
ADH_adj_time = ADH release adjustment time {h}
ADH_clear_del = Antidiuretic hormone clearance delay {h}
ADH_conc_in_plasma = Plasma Antidiuretic hormone concentration {pg/ml}
ADH_ratio_to_normal = Antidiuretic hormone concentration ratio with reference to its normal {dimensionless}
desired_ADH_conc = Desired ADH concentration {pg/ml}
desired_ADH_release = Desired antidiuretic hormone release {pg/h}
des_ADH_in_plasma = Desired antidiuretic hormone in plasma {pg}
max_pool_cap = Maximum ADH pool capacity {pg}
normal_ADH_conc = Normal Antidiuretic hormone concentration in man {pg/ml}
normal_BV = Normal blood volume {L}
pct_chg_BV = Percent change in Blood volume {dimensionless}
pct_decrease_in_cap = Percent decrease in ADH pool capacity {dimensionless}
pool_capacity = ADH pool capacity {pg}
eff_of_ADH_avail = Effect of ADH availability in the pool {dimensionless}
eff_of_BV_on_ADH = effect of Blood Volume on ADH {dimensionless}
eff_of_ECOsm_on_ADH = effect of Extracellular Osmolality (ECOsm) on ADH {dimensionless}
normal_PV = Normal Plasma Volume {L}
eff_of_cap_on_ADH_prod = Effect of Pool Capacity on ADH production {dimensionless}
normal_ADH_prod = Normal ADH Production Rate {pg/h}

ALD = Amount of aldosterone {ng}

ALD_adjust = Aldosterone adjustment rate {ng/h}

ALD_conc_perceived = Perceived aldosterone concentration in plasma {ng/dl}

ALD_correct = Perceived Aldosterone Concentration Correction Rate {ng/h}

Renin = Amount of renin {ng}

renin_secr = Renin Secretion Rate {ng/h}

ALD_adj_time = Aldosterone adjustment time {h}

ALD_conc = Aldosterone Concentration in Plasma {ng/dl}

ALD_conc_normal = Normal Aldosterone Concentration in Plasma {ng/dl}

ALD_conc_perceive_del = Aldosterone Concentration Perceive Delay {h}

ALD_ratio = Perceived Aldosterone Concentration with Reference to its Normal Value
{dimensionless}

ALD_ratio_to_normal = Aldosterone Concentration with Reference to its Normal
{dimensionless}

ANG_conc = Angiotensin Concentration {ng}

normal_TBW = Normal Value of Total Body Water {ml}

desired_ALD = Desired amount of aldosterone in body water {ng}

desired_ALD_conc = Desired aldosterone concentration {ng/dl}

desired_renin = Desired Renin Amount {ng}

desired_renin_activity = Desired Renin Activity {dimensionless}

log_ANG = Logarithm of Angiotensin Concentration {dimensionless}

normal_renin_activity = The Normal Renin Activity in Man {ng/L}

renin_del = Renin Delay {h}

renin_ratio = Renin Ratio to Normal {dimensionless}

eff_of_MAP_on_renin = Effect of Mean Arterial Pressure on Renin {dimensionless}

eff_of_ANG_on_ALD = Effect of Angiotensin on Aldosterone Secretion {dimensionless}

eff_of_ECNa_conc_on_ALD = Effect of Extracellular Sodium Concentration (ECNa Conc)
on Aldosterone Secretion {dimensionless}

ANH_in_plasma = Atrial Natriuretic Hormone in Plasma {ng}

ANH_production = Atrial Natriuretic Hormone Production {ng}

ANH_clear_del = Atrial Natriuretic Hormone Clearance Delay {h}

ANH_conc_in_plasma = Plasma Atrial Natriuretic Hormone Concentration {ng/L}

ANH_ratio_to_normal = Atrial Natriuretic Hormone Concentration with Reference to its Normal Value {dimensionless}

basal_ANH_conc = Basal Atrial Natriuretic Hormone Concentration {ng/ml}

desired_ANH_conc = Desired Atrial Natriuretic Hormone Concentration {ng/l}

desired_ANH_in_plasma = Desired ANH in Plasma {ng}

eff_of_ANH_on_na_excr = Effect of Atrial Natriuretic Hormone on Sodium Excretion {dimensionless}

eff_of_ANH = Effect of Atrial Natriuretic Hormone on Sodium Excretion {dimensionless}

eff_of_ECFV_on_ANH = Effect of Percent Change in Extracellular Fluid Volume on Atrial Natriuretic Hormone {dimensionless}

eff_of_ecf_icf_ratio_on_ANH = Effect of ECF/ICF ratio on Atrial Natriuretic Hormone {dimensionless}

ecf_over_icf = Extracellular-intracellular fluid volume ratio {dimensionless}

normal_ECFV = Normal value of Extracellular Fluid Volume {L}

pct_chg_ECFV: Percent change in Extracellular fluid volume {dimensionless}

B.4. Urinary Sodium Concentration Sector

Variables used in the Urinary Sodium Concentration sector are listed below;

implied_UNa_conc = Implied Urinary Sodium Concentration {mEq/L}

implied_UNa_conc_by_ADH = Implied Urinary Sodium Concentration by ADH {mEq/l}

max_att_UNa_conc = Maximum Attainable Urinary Sodium Concentration {mEq/L}

max_UNa_conc = Maximum Urinary Sodium Concentration that the Human Kidney can Attain {mEq/L}

min_UNa_conc = Minimum Urinary Sodium Concentration that the Human Kidney can Attain {mEq/L}

GFRo = Normal Value of the Glomerular Filtration Rate {ml/min}

normal_UNa_conc = Normal Urinary Sodium Concentration in Man {mEq/L}

potential_escape = Potential Escape from Effects of High Circulating Levels of ADH
{dimensionless}

prc_chg_GFR = Percent Change in Glomerular Filtration Rate {dimensionless}

Urinary_Na_conc = Urinary Sodium Concentration {mEq/L}

eff_of_GFR_on_UNa = Effect of GFR on Urinary Sodium Concentration {dimensionless}

eff_of_max_att_UNa_on_UNa = Effect of Maximum Attainable Urinary Sodium Concentration on Urinary Sodium Concentration {dimensionless}

escape = Escape from Effects of High Circulating Levels of ADH {dimensionless}

eff_of_ADH = Effect of Antidiuretic Hormone to Urinary Sodium Concentration
{dimensionless}

B.5. Treatment Sector Group

Variables used in the Diuretic, Aquaretic and Intravenous Fluid Infusion (Intr. Fluid Inf) subsectors are listed below;

Diuretic_in_Blood = Amount of Active Diuretic in Blood {mg}

intravenous_diuretic = Diuretic Given to the Bloodstream {mg/DT}

diuretic_absorption = Diuretic Absorption {mg/h}

clear_diuretic = Clearance of Diuretic {mg/h}

Diuretic_in_Stomach = Amount of Diuretic in Stomach {mg}

oral_diuretic = Oral Diuretic Given {mg/DT}

diuretic_absorption = Diuretic Absorption {mg/h}

Perceived_Diuretic_conc = Perceived Diuretic Concentration in Plasma {mg}

correct_diuretic_conc = Correction of Perceived Diuretic Concentration {mg/L/h}

diuretic_abs_const = Diuretic Absorption Constant: the Exponential Time Constant Associated with the Absorption Half-life {1/h}

diuretic_blood_conc = Diuretic Concentration in Blood: This converter calculates the concentration of the drug in the bloodstream. {mg/L}

diuretic_clear_del = Diuretic Clearance Delay {h}

diuretic_del = Diuretic Delay {h}

diuretic_stomach_conc = Diuretic Stomach Concentration {mg/L}

DOSE_DIURETIC = Dose of Diuretic Given {mg}

Intravenous_Dose_Diuretic = Intravenous Dose Diuretic {mg}

Oral_Dose_Diuretic = Oral Dose Diuretic {mg}

eff_of_diuretic_on_na_excr = Effect of Diuretic on Sodium Excretion {dimensionless}

eff_of_diuretic_on_UNa = Effect of Diuretic on Urinary Sodium Concentration
{dimensionless}

Aquaretic_in_Blood = Amount of Active Aquaretic (or Antidiuretic Hormone (ADH) antagonist) in Blood {mg}

intravenous_aquaretic = Aquaretic Given to the Bloodstream {mg/DT}

aquaretic_absorption = Aquaretic Absorption {mg/h}

clear_aquaretic = Clearance of Aquaretic {mg/h}

Aquaretic_in_Stomach = Aquaretic in Stomach {mg}

oral_aquaretic = Oral Aquaretic Given {mg/h}

aquaretic_absorption = Aquaretic Absorption {mg/h}

Perceived_Aquaretic_conc = Perceived Aquaretic Concentration {mg/L}

correct_aquaretic_conc = Correction of Perceived Aquaretic Concentration {mg/L/h}

aquaretic_clear_del = ADH Antagonist (Aquaretic) Clearance Delay {h}

aquaretic_abs_const = Aquaretic Absorption Constant: the exponential time constant associated with the absorption half-life. {1/h}

aquaretic_blood_conc = Aquaretic Concentration in Blood {mg/L}

aquaretic_del = Aquaretic Delay {h}

aquaretic_stomach_conc = Aquaretic Stomach Volume {mg/L}

DOSE_ADH_ANTAGONIST = Dose of Aquaretic Given {mg}

intravenous = {dimensionless}

Intravenous_Dose_Aquaretic = Intravenous Dose Aquaretic {mg}

Oral_Dose_Aquaretic = Oral Dose Aquaretic {mg}

stomach_volume = Stomach Volume {L}

eff_of_aquaretic_on_ADH = Effect of Aquaretic on Antidiuretic Hormone (ADH)
{dimensionless}

eff_of_aquaretic_on_UNa = Effect of Aquaretic on Urinary Sodium Concentration:
{dimensionless}

Sodium_Load_Given = Total Sodium Load Given in the Course of Treatment {mEq}

na_in = Infused Sodium {mEq/h}

Water_Load_given = Total Water Load Given in the Course of Treatment {ml}

water_in = Infused Water {ml/h}

HYPERTONIC_3%_SALINE = Hypertonic Saline Infused to the Patient: Hypertonic saline 3% has an osmolality (about 900 mosm/l) three times that of plasma {ml/h}

HYPOTONIC_SALINE = Hypotonic Saline Infused to the Patient: Hypotonic solutions vary between 0.45% and 0, 18 % saline (77 and 30 mEq/L Na). They have an osmolality smaller than the normal plasma osmolality {ml/h}

ISOTONIC_SALINE = Isotonic Saline Infused to the Patient: Isotonic saline is 0,9% saline (142 mEq/L Na). This solution has an [Na+] similar to that of the extracellular fluid which effectively limits its fluid distribution to the ECF {ml/h}

na_infused = Amount of Sodium Infused to the Patient {mEq/h}

water_infused = Amount of Water Infused to the Patient {ml/h}

B.6. Game Related-Not in a Sector

Variables which do not belong to any sector, but rather used for the game purposes, are listed below;

Na_In_Current_Period = Total Amount of Sodium given to the Patient in the Current Period {mEq}

na_intake_period = Total Sodium Intake Rate of the Patient {mEq/h}

na_out_period = Total Sodium Loss Rate of the Patient {mEq/h}

Na_Out_Current_Period = Total Sodium Lost by the Patient in the Current Period {mEq}

na_lost_period = Sodium Loss Rate in Urine {mEq/h}

na_lost_out_period = Reset the Stock of the Current Sodium Loss {Eq/h}

Total_Change_in_ECNa_conc = Total Change in Extracellular Sodium Concentration {mEq/L}

rate_of_change = Rate of Change in ECNa Concentration {mEq/L/h}

Urine_Output_Current_Period = Total Urine Collected, which takes the value of 0 between measurements {L}

UFlow_in_period = Hourly Urine Flow {ml/h}
UFlow_out_period = Reset the Current Urine Stock {ml/h}
Urine_Period = Amount of Urine of the Corresponding Period {ml}
urine_flow [1] = Urine Flow of the First Period {ml/h}

urine_flow [30] = Urine Flow of the Thirtieth Period {ml/h}
WaterInPeriod = Amount of Water Intake of the Corresponding Period {ml}
fluid_intake [1] = Water Intake Rate of the First Period {ml/h}

fluid_intake [30] = Water Intake Rate of the Thirtieth Period {ml/h}
Water_Intake_Current_Period = Total Amount of Water Given to the Patient in the Current Decision Period {ml}
water_out_period = Reset the Stock of the Current Water Intake {ml/h}
Aldosterone_Ratio_to_Normal = Aldosterone Ratio to Normal, which takes the value of 0 between measurements {dimensionless}
Antidiuretic_Hormone_Ratio_to_Normal = ADH Ratio to Normal, which takes the value of 0 between measurements {dimensionless}
Atrial_Natriuretic_Hormone_Ratio_to_Normal = ANH Ratio to Normal, which takes the value of 0 between measurements {dimensionless}
bedside_attendant = Messages of the Bedside Attendant related to ECNa Concentration {dimensionless}
Body_Water__L = Amount of TBW, which takes the value of 0 between measurements {L}
cumulative_interval = Current Time Period {dimensionless}
Daily_ECNa_correct = Absolute Rate of Daily Change in ECNa Concentration {mEq/L}
Daily_ECNa_Correction_Rate = Daily Correction Rate of ECNa Concentration, which takes the value of 0 between measurements {mEq/L/d}
Daily_ECNa_Corr_Lower_Limit = Lower Limit of Daily ECNa Correction Rate {mEq/L/d}
Daily_ECNa_Corr_Upper_Limit = Upper Limit of Daily ECNa Correction Rate {mEq/L/d}
Daily_Fluid_Intake = Dummy Converter for Daily Water Intake
decision_period = "Pause Interval" of the Simulation {h}

dec_variable_period = A variable which takes the value of 1 on the multiples of the selected decision period, and takes the value of 0 otherwise {dimensionless}

Drug_Dosage_Given = Dummy Converter for the Given Drug Dosage {mg}

ECNa_conc_an_hour = Extracellular Sodium Concentration Delayed One Hour {mEq/L}

ECNa_conc_daily = Extracellular Sodium Concentration Delayed One Day {mEq/L}

ECNa_correction = Absolute Rate of Hourly Change in ECNa Concentration {mEq/L}

eight_hours = Switch variable which takes the value of 1 if 8 hours is selected as the decision period {dimensionless}

Estimated_Insensible_Loss_in_that_Period_L = Insensible Loss of the Decision Period {L}

Extracellular_Fluid_Volume_L = Extracellular Fluid Volume, which takes the value of 0 between measurements {L}

Extracellular_Sodium_Concentration_mEqL = Extracellular Sodium Concentration, which takes the value of 0 between measurements {mEq/L}

Extracellular_Sodium_mEq = Amount of Extracellular Sodium, which takes the value of 0 between measurements {mEq}

four_hours = Switch variable which takes the value of 1 if 4 hours is selected as the decision period {dimensionless}

Glomerular_Filtration_Rate_ml_min = Glomerular Filtration Rate, which takes the value of 0 between measurements {ml/min}

heaven = Message from heaven when the patient dies due to low ECNa concentration {dimensionless}

heaven2 = Message from heaven when the patient dies due to high blood pressure {dimensionless}

Hourly_ECNa_Correction_Rate = Hourly Correction Rate of ECNa concentration, which takes the value of 0 between measurements {mEq/L/h}

Hourly_ECNa_Corr_Lower_Limit = Lower limit for Hourly Correction Rate of ECNa Concentration {mEq/L/h}

Hourly_ECNa_Corr_Upper_Limit = Upper Limit for Hourly Correction Rate of ECNa Concentration {mEq/L/h} {mEq/L/h}

Init_ADH = Initial Value of Antidiuretic Hormone in Plasma for the Game {pg}

Init_ADH_Pool = Initial Value of Antidiuretic Hormone Pool for the Game {pg}

Init_ALD = Initial Value of Aldosterone for the Game {ng}

Init_ANH = Initial value of Atrial Natriuretic Hormone for the game {ng}
Init_ECNa = Initial Value of ECNa for the Game {mEq}
Init_Gut = Initial Value of Gut Water for the Game {ml}
Init_Renin = Initial Value of Renin for the Game {ng}
Init_TBW = Initial Value of Total Body Water for the Game {ml}
Intracellular_Fluid_Volume__L = Intracellular Fluid Volume, which takes the value of 0 between measurements {L}
Isotonic_Saline_Infusion_ = Dummy Converter for Isotonic Saline Infusion {ml}
Mean_Arterial_Pressure__mmHg = Mean Arterial Pressure, which takes the value of 0 between measurements {mmHg}
na_intake_times = Sodium Intake Ratio to its Reference Value {dimensionless}
Normal_ECNa = Normal Value for the Extracellular Sodium {ECNa}
Normal_ECNa_conc = Normal Value for the Extracellular Sodium Concentration {mEq/min}
Normal_GFR = Normal Value for the Glomerular Filtration Rate {ml/min}
Normal_ICFV = Normal Value for the Intracellular Fluid Volume {L}
Normal_MAP = Normal Value for the Mean Arterial Pressure {mmHg}
Normal_Sodium_Turnover_of_a_Healthy_Person__mEq = Normal Sodium Intake-Loss in the Corresponding Decision Period {mEq}
Normal_Body_Water = Normal Value for the Total Body Water {L}
Normal_UFlow = Normal urine flow rate in a minute {ml/min}
Normal_Water_Turnover_of_a_Healthy_Person__L = Normal Water Intake/Loss in the Corresponding Decision Period {L}
pause_variable = Pause Variable which pauses the game if time is a multiple of the selected decision period {dimensionless}
rate_of_daily_correct = Daily Correction Rate of ECNa Concentration {mEq/L/d}
rate_of_hourly_correct = Hourly Correction Rate of ECNa Concentration {mEq/L/h}
Renin_Ratio_to_Normal = Renin Ratio to Normal, which takes the value of 0 between measurements {dimensionless}
set_ADH_conc = The Set Level of the Antidiuretic Hormone Concentration in Man {pg/ml}
Sodium_Intake_in_current_Period__mEq = Total Sodium Intake, which takes the value of 0 between measurements {mEq}

Sodium_Lost_in_Current_Period_mEq = Total Sodium Lost, which takes the value of 0 between measurements {mEq}

superiors = Message From Superiors Regarding to the Hourly Correction {dimensionless}

superiors2 = Message from Superiors regarding to the Daily Correction {dimensionless}

superiors3 = Message from Superiors regarding to the Mean Arterial Pressure {dimensionless}

superiors4 = Message from Superiors regarding to the Body Water {dimensionless}

superiors5 = Message from Superiors regarding to the Extracellular Fluid Volume {dimensionless}

superiors6 = Message from Superiors regarding to the Extracellular Sodium {dimensionless}

Time_Stamp = TIME {h}

twelve_hours = Switch Variable which takes the value of 1 if 12 hours is selected as the decision period {dimensionless}

Urinary_Na_Concentration_mEqL = Urinary Sodium Concentration, which takes the value of 0 between measurements {mEq/L}

Urine_Out_Current_Period = Urine amount of the patient in the current decision period {L}

Urine_Output_in_current_Period_L = Total Urine Output, which takes the value of 0 between measurements {L}

WaterIn_current_period = Total Amount of Water Given to the Patient in the current Decision Period {L}

Water_Intake_in_current_Period_L = Amount of Total Water Intake, which takes the value of 0 between measurements {L}

water_intake_rate = Water Intake Rate (=drinking+water infused) {ml/h}

APPENDIX C: EQUATIONS OF THE GAME MODEL

Aquaretic (or ADH Antagonist)

$$\text{Aquaretic_in_Blood}(t) = \text{Aquaretic_in_Blood}(t - dt) + (\text{intravenous_aquaretic} + \text{aquaretic_absorption} - \text{clear_aquaretic}) * dt$$

$$\text{INIT Aquaretic_in_Blood} = 0 \text{ \{mg\}}$$

INFLOWS:

$$\text{intravenous_aquaretic} = \text{intravenous} * \text{DOSE_ADH_ANTAGONIST} / \text{DT} \text{ \{mg/DT\}}$$

$$\text{aquaretic_absorption} = (\text{aquaretic_stomach_conc} - \text{aquaretic_blood_conc}) * \text{aquaretic_abs_const} * \text{stomach_volume} \text{ \{mg/h\}}$$

OUTFLOWS:

$$\text{clear_aquaretic} = \text{Aquaretic_in_Blood} / \text{aquaretic_clear_del} \text{ \{mg/h\}}$$

$$\text{Aquaretic_in_Stomach}(t) = \text{Aquaretic_in_Stomach}(t - dt) + (\text{oral_aquaretic} - \text{aquaretic_absorption}) * dt$$

$$\text{INIT Aquaretic_in_Stomach} = 0 \text{ \{mg\}}$$

INFLOWS:

$$\text{oral_aquaretic} = \text{oral} * \text{DOSE_ADH_ANTAGONIST} / \text{DT} \text{ \{mg/h\}}$$

OUTFLOWS:

$$\text{aquaretic_absorption} = (\text{aquaretic_stomach_conc} - \text{aquaretic_blood_conc}) * \text{aquaretic_abs_const} * \text{stomach_volume} \text{ \{mg/h\}}$$

$$\text{Perceived_Aquaretic_conc}(t) = \text{Perceived_Aquaretic_conc}(t - dt) + (\text{correct_aquaretic_conc}) * dt$$

$$\text{INIT Perceived_Aquaretic_conc} = \text{aquaretic_blood_conc} \text{ \{mg/L\}}$$

INFLOWS:

$$\text{correct_aquaretic_conc} = (\text{aquaretic_blood_conc} - \text{Perceived_Aquaretic_conc}) / \text{aquaretic_del} \text{ \{mg/L/h\}}$$

$$\text{aquaretic_abs_const} = .693 / 2 \text{ \{1/h\}}$$

$$\text{aquaretic_blood_conc} = \text{Aquaretic_in_Blood} / \text{BV} \text{ \{mg/L\}}$$

$$\text{aquaretic_clear_del} = 1.5 \text{ \{h\}}$$

$$\text{aquaretic_del} = 1 \text{ \{h\}}$$

$$\text{aquaretic_stomach_conc} = \text{Aquaretic_in_Stomach} / \text{stomach_volume} \text{ \{mg/L\}}$$

$DOSE_ADH_ANTAGONIST = 0 \text{ \{mg\}}$
 $intravenous = 0 \text{ \{dimensionless\}}$
 $Intravenous_Dose_ADH_Antagonist = intravenous * DOSE_ADH_ANTAGONIST \text{ \{mg\}}$
 $oral = 1 \text{ \{dimensionless\}}$
 $Oral_Dose_ADH_Antagonist = oral * DOSE_ADH_ANTAGONIST \text{ \{mg\}}$
 $stomach_volume = 0.5 \text{ \{L\}}$
 $eff_of_aquaretic_on_ADH = GRAPH(Perceived_Aquaretic_conc \text{ \{dimensionless\}})$
 $(0.00, 0.00), (10.0, 0.005), (20.0, 0.045), (30.0, 0.15), (40.0, 0.31), (50.0, 0.59), (60.0, 1.04),$
 $(70.0, 1.42), (80.0, 1.70), (90.0, 1.88), (100, 2.00)$
 $eff_of_aquaretic_on_UNa = GRAPH(Perceived_Aquaretic_conc \text{ \{dimensionless\}})$
 $(0.00, 1.00), (2.50, 0.915), (5.00, 0.78), (7.50, 0.595), (10.0, 0.415), (12.5, 0.31), (15.0,$
 $0.24), (17.5, 0.2), (20.0, 0.178), (22.5, 0.163), (25.0, 0.155)$

ADH

$ADH_in_plasma(t) = ADH_in_plasma(t - dt) + (actual_ADH_release - ADH_clear) * dt$
 $INIT ADH_in_plasma = Init_ADH$

INFLOWS:

$actual_ADH_release = desired_ADH_release * eff_of_ADH_avail \text{ \{pg/h\}}$

OUTFLOWS:

$ADH_clear = ADH_in_plasma / ADH_clear_del \text{ \{pg/h\}}$
 $ADH_Pool(t) = ADH_Pool(t - dt) + (ADH_production - actual_ADH_release) * dt$
 $INIT ADH_Pool = 500000 \text{ \{pg\}}$

INFLOWS:

$ADH_production = eff_of_cap_on_ADH_prod * normal_ADH_prod * (100 -$
 $pct_decrease_in_cap) / 100$

OUTFLOWS:

$actual_ADH_release = desired_ADH_release * eff_of_ADH_avail \text{ \{pg/h\}}$
 $ADH_adj_time = 1/3 \text{ \{h\}}$
 $ADH_clear_del = 1/4$
 $ADH_conc_in_plasma = ADH_in_plasma / normal_PV / 1000 \text{ \{pg/ml\}}$
 $ADH_ratio_to_normal = ADH_conc_in_plasma / normal_ADH_conc \text{ \{dimensionless\}}$
 $desired_ADH_conc =$
 $MAX(0, set_ADH_conc + eff_of_ECOsm_on_ADH + eff_of_BV_on_ADH + eff_of_aquaretic$
 $_on_ADH)$

$\text{desired_ADH_in_plasma} = \text{desired_ADH_conc} * \text{normal_PV} * 1000 \text{ \{pg\}}$
 $\text{desired_ADH_release} = \text{MAX}(0, (\text{desired_ADH_in_plasma} - \text{ADH_in_plasma}) / \text{ADH_adj_time} + \text{ADH_clear}) \text{ \{pg/h\}}$
 $\text{max_pool_cap} = 500000 \text{ \{pg\}}$
 $\text{normal_ADH_conc} = 2 \text{ \{pg/ml\}}$
 $\text{normal_ADH_prod} = 24000 \text{ \{pg/h\}}$
 $\text{normal_BV} = 5 \text{ \{L\}}$
 $\text{normal_PV} = 3 \text{ \{L\}}$
 $\text{pct_chg_BV} = (\text{BV} - \text{normal_BV}) / \text{normal_BV} * 100 \text{ \{dimensionless\}}$
 $\text{pct_decrease_in_cap} = 0 \text{ \{dimensionless\}}$
 $\text{pool_cap} = \text{max_pool_cap} * ((100 - \text{pct_decrease_in_cap}) / 100) \text{ \{pg\}}$
 $\text{eff_of_ADH_avail} = \text{GRAPH}(\text{ADH_Pool} / \text{max_pool_cap} \text{ \{dimensionless\}})$
 (0.00, 0.00), (0.0708, 0.368), (0.142, 0.632), (0.212, 0.795), (0.283, 0.865), (0.354, 0.913),
 (0.425, 0.937), (0.496, 0.958), (0.567, 0.968), (0.637, 0.981), (0.708, 0.99), (0.779, 0.996),
 (0.85, 1.00)
 $\text{eff_of_BV_on_ADH} = \text{GRAPH}(\text{pct_chg_BV})$
 (-25.0, 40.0), (-20.8, 24.5), (-16.7, 13.0), (-12.5, 6.00), (-8.33, 1.60), (-4.17, 0.00), (5.33e-
 015, 0.00), (4.17, 0.00), (8.33, -0.5), (12.5, -1.35), (16.7, -2.40), (20.8, -4.05), (25.0, -6.15)
 $\text{eff_of_cap_on_ADH_prod} = \text{GRAPH}(\text{ADH_Pool} / \text{pool_cap} \text{ \{dimensionless\}})$
 (0.00, 6.85), (0.1, 6.76), (0.2, 6.58), (0.3, 6.31), (0.4, 6.04), (0.5, 5.68), (0.6, 5.14), (0.7,
 4.46), (0.8, 3.65), (0.9, 2.40), (1, 1.00)
 $\text{eff_of_ECOsm_on_ADH} = \text{GRAPH}(\text{pct_chg_ECOsm} \text{ \{dimensionless\}})$
 (-3.00, -2.00), (-2.75, -2.00), (-2.50, -1.98), (-2.25, -1.91), (-2.00, -1.79), (-1.75, -1.63), (-
 1.50, -1.42), (-1.25, -1.20), (-1.00, -0.95), (-0.75, -0.71), (-0.5, -0.47), (-0.25, -0.24), (0.00,
 0.00), (0.25, 0.25), (0.5, 0.5), (4.75, 4.75), (5.00, 5.00)

ANH

$\text{ANH_in_plasma}(t) = \text{ANH_in_plasma}(t - dt) + (\text{ANH_production}) * dt$

$\text{INIT ANH_in_plasma} = \text{Init_ANH}$

INFLOWS:

$\text{ANH_production} = (\text{desired_ANH_in_plasma} - \text{ANH_in_plasma}) / \text{ANH_clear_del} \text{ \{pg/h\}}$

$\text{ANH_clear_del} = 0.1 \text{ \{h\}}$

$\text{ANH_conc_in_plasma} = \text{ANH_in_plasma} / \text{normal_PV} \text{ \{pg/l\}}$

$\text{ANH_ratio_to_normal} = \text{ANH_conc_in_plasma} / \text{basal_ANH_conc}$

basal_ANH_conc = 40 {pg/ml}
 desired_ANH_conc =
 basal_ANH_conc*eff_of_ECFV_on_ANH*eff_of_ecf_icf_ratio_on_ANH {pg/l}
 desired_ANH_in_plasma = desired_ANH_conc*normal_PV {pg}
 ecf_over_icf = Extracellular_Fluid_Vol/Intracellular_Fluid_Vol {dimensionless}
 normal_ECFV = 15 {L}
 pct_ch_ECFV = (Extracellular_Fluid_Vol-normal_ECFV)/normal_ECFV*100
 {dimensionless}
 eff_of_ECFV_on_ANH = GRAPH(pct_ch_ECFV)
 (-10.0, 0.11), (-8.75, 0.17), (-7.50, 0.23), (-6.25, 0.295), (-5.00, 0.385), (-3.75, 0.49), (-2.50,
 0.595), (-1.25, 0.7), (0.00, 1.00), (1.25, 1.45), (2.50, 2.17), (3.75, 3.02), (5.00, 4.15), (6.25,
 5.50), (7.50, 6.65), (8.75, 7.50), (10.0, 8.10), (11.3, 8.50), (12.5, 8.85), (13.8, 9.15), (15.0,
 9.15)
 eff_of_ecf_icf_ratio_on_ANH = GRAPH(ecf_over_icf)
 (0.3, 0.2), (0.36, 0.452), (0.42, 0.668), (0.48, 0.83), (0.54, 0.938), (0.6, 1.00), (0.66, 1.15),
 (0.72, 1.38), (0.78, 1.72), (0.84, 2.29), (0.9, 3.03)

Body Water

Drink_Mode(t) = Drink_Mode(t - dt) + (mode_on - mode_off) * dt
 INIT Drink_Mode = 0 {dimensionless}

INFLOWS:

mode_on = key_on*key_on_2 {dimensionless}

OUTFLOWS:

mode_off = key_off_2*key_off {dimensionless}

Gut(t) = Gut(t - dt) + (drinking - gut_to_in) * dt

INIT Gut = Init_Gut {ml}

INFLOWS:

drinking =

unrestricted_intake*(unrestricted_drinking)+mild_water_restriction*(IF(mild/24)<(unrestr
 icted_drinking)THEN(mild/24)ELSE(unrestricted_drinking))+severe_water_restriction*((IF
 (severe/24)<(unrestricted_drinking)THEN(severe/24)ELSE(unrestricted_drinking)))

OUTFLOWS:

gut_to_in = Gut/time_to_reach_body {ml/h}

TBW(t) = TBW(t - dt) + (gut_to_in + water_infusion - urine_flow__ - insensible_loss) * dt

INIT TBW = Init_TBW {ml}
 INFLOWS:
 gut_to_in = Gut/time_to_reach_body {ml/h}
 water_infusion = water_infused {ml/h}
 OUTFLOWS:
 urine_flow_ = MAX(min_urine_flow_,implied_UFlow) {ml/h}
 insensible_loss = 840/24 {ml/h}
 Daily_Water_Intake = drinking*24/1000
 discontinuous_drinking = Drink_Mode*drinking_rate {ml/h}
 drinking_rate = 4000{ml/h}
 ECNa_ratio_to_total = Extracellular_Na/(Extracellular_Na+IK)
 Extracellular_Fluid_Vol = TBW*ECNa_ratio_to_total/1000 {L}
 implied_UFlow = na_out_in_urine/Urinary_Na_conc*1000 {ml/h}
 Intracellular_Fluid_Vol = Total_Body_Water-Extracellular_Fluid_Vol {L}
 key_off = if Drink_Mode=0 then 0 else 1/DT {dimensionless}
 key_off_2 = SWITCH(water_sensed_by_body,u_limit) {dimensionless}
 key_on = if Drink_Mode=0 then 1/DT else 0 {dimensionless}
 key_on_2 = SWITCH(l_limit,water_sensed_by_body) {dimensionless}
 l_limit = normal_TBW*(100-pct_chg_in_TBW)/100 {ml}
 mild = 1700 {ml}
 mild_water_restriction = 0 {dimensionless}
 min_urine_flow_ = 0.3*60 {ml/h}
 normal_drinking = 2280/24 {ml/h}
 normal_TBW = 40000 {ml}
 pct_change_hydration = (Total_Body_Water-40)/40*100 {dimensionless}
 pct_chg_in_TBW = 0.75
 plasma_fraction = 0.6 {dimensionless}
 Plasma_Volume = plasma_fraction*BV {L}
 severe = 800 {ml}
 severe_water_restriction = 0 {dimensionless}
 time_to_reach_body = 1/2 {h}
 Total_Body_Water = TBW/1000 {L}
 unrestricted_drinking = normal_drinking*disease_eff_of_ECOsm_on_drinking {ml/h}

```

unrestricted_intake = 1 {dimensionless}
u_limit = normal_TBW*(100+pct_chg_in_TBW)/100 {ml}
water_lost = (insensible_loss+urine_flow_) {ml/h}
water_sensed_by_body = TBW+Gut {ml}
BV = GRAPH(Extracellular_Fluid_Vol {L})
(9.00, 4.50), (11.0, 4.55), (13.0, 4.72), (15.0, 5.00), (17.0, 5.46), (19.0, 6.03), (21.0, 6.50),
(23.0, 6.77), (25.0, 6.90), (27.0, 6.96), (29.0, 6.98)
disease_eff_of_ECOsm_on_drinking = GRAPH(pct_chg_ECOsm)
(-25.0, 0.663), (-22.9, 0.75), (-20.8, 0.838), (-18.8, 0.95), (-16.7, 1.06), (-14.6, 1.18), (-12.5,
1.33), (-10.4, 1.45), (-8.33, 1.60), (-6.25, 1.75), (-4.17, 1.95), (-2.08, 2.20), (-8.88e-016,
2.42), (2.08, 2.65), (4.17, 2.94), (6.25, 3.25), (8.33, 3.60), (10.4, 4.25), (12.5, 4.95), (14.6,
6.25), (16.7, 7.53), (18.8, 8.70), (20.8, 9.51), (22.9, 9.96), (25.0, 10.0)
eff_of_ECOsm_on_drinking = GRAPH(pct_chg_ECOsm {dimensionless})
(-10.0, 0.332), (-9.17, 0.346), (-8.33, 0.363), (-7.50, 0.391), (-6.67, 0.426), (-5.83, 0.475), (-
5.00, 0.531), (-4.17, 0.601), (-3.33, 0.671), (-2.50, 0.741), (-1.67, 0.818), (-0.833, 0.913),
(2.22e-016, 1.00), (0.833, 1.14), (1.67, 1.45), (2.50, 1.81), (3.33, 2.35), (4.17, 3.07), (5.00,
4.20), (5.83, 5.95), (6.67, 7.53), (7.50, 8.70), (8.33, 9.51), (9.17, 9.96), (10.0, 10.0)
Glomerular_Filtr_Rate = GRAPH(Mean_Arter_Press {ml/min})
(20.0, 0.00), (25.0, 9.60), (30.0, 19.2), (35.0, 28.8), (40.0, 38.4), (45.0, 48.0), (50.0, 57.6),
(55.0, 67.2), (60.0, 76.8), (65.0, 86.4), (70.0, 96.0), (75.0, 104), (80.0, 110), (85.0, 115),
(90.0, 119), (95.0, 122), (100, 125), (105, 128), (110, 130), (115, 132), (120, 133), (125,
135), (130, 135), (135, 136), (140, 136), (145, 136), (150, 136)
Mean_Arter_Press =GRAPH(BV {mmHg})
(4.40, 58.0), (4.60, 72.0),..... (6.20, 184), (6.40, 200)

```

Diuretic

```

Diuretic_in_Blood(t) = Diuretic_in_Blood(t - dt) + (intravenous_diuretic +
diuretic_absorption - clear_diuretic) * dt
INIT Diuretic_in_Blood = 0 {mg}
INFLOWS:
intravenous_diuretic = intravenous*DOSE_DIURETIC/DT {mg/DT}
diuretic_absorption = (diuretic_stomach_conc-diuretic_blood_conc)*diuretic_abs_const*
stomach_volume {mg/h}
OUTFLOWS:

```

$\text{clear_diuretic} = \text{Diuretic_in_Blood}/\text{diuretic_clear_del} \text{ \{mg/h\}}$
 $\text{Diuretic_in_Stomach}(t) = \text{Diuretic_in_Stomach}(t - dt) + (\text{oral_diuretic} - \text{diuretic_absorption}) * dt$
 $\text{INIT Diuretic_in_Stomach} = 0 \text{ \{mg\}}$
 INFLOWS:
 $\text{oral_diuretic} = \text{oral} * \text{DOSE_DIURETIC}/\text{DT} \text{ \{mg/DT\}}$
 OUTFLOWS:
 $\text{diuretic_absorption} = (\text{diuretic_stomach_conc} - \text{diuretic_blood_conc}) * \text{diuretic_abs_const} * \text{stomach_volume} \text{ \{mg/h\}}$
 $\text{Perceived_Diuretic_conc}(t) = \text{Perceived_Diuretic_conc}(t - dt) + (\text{correct_diuretic_conc}) * dt$
 $\text{INIT Perceived_Diuretic_conc} = \text{diuretic_blood_conc} \text{ \{mg\}}$
 INFLOWS:
 $\text{correct_diuretic_conc} = (\text{diuretic_blood_conc} - \text{Perceived_Diuretic_conc})/\text{diuretic_del} \text{ \{mg/L/h\}}$
 $\text{diuretic_abs_const} = .693/2 \text{ \{1/h\}}$
 $\text{diuretic_blood_conc} = \text{Diuretic_in_Blood}/\text{BV} \text{ \{mg/L\}}$
 $\text{diuretic_clear_del} = 1.5 \text{ \{h\}}$
 $\text{diuretic_del} = 0.3 \text{ \{h\}}$
 $\text{diuretic_stomach_conc} = \text{Diuretic_in_Stomach}/\text{stomach_volume} \text{ \{mg/L\}}$
 $\text{DOSE_DIURETIC} = 0 \text{ \{mg\}}$
 $\text{Intravenous_Dose_Diuretic} = \text{intravenous} * \text{DOSE_DIURETIC} \text{ \{mg\}}$
 $\text{Oral_Dose_Diuretic} = \text{oral} * \text{DOSE_DIURETIC} \text{ \{mg\}}$
 $\text{eff_of_diuretic_on_na_excr} = \text{GRAPH}(\text{Perceived_Diuretic_conc} \text{ \{dimensionless\}})$
 $(0.00, 1.00), (2.50, 1.08), (5.00, 1.40), (7.50, 1.80), (10.0, 2.33), (12.5, 3.05), (15.0, 3.95),$
 $(17.5, 4.90), (20.0, 5.60), (22.5, 5.90), (25.0, 6.00)$
 $\text{eff_of_diuretic_on_UNa} = \text{GRAPH}(\text{Perceived_Diuretic_conc} \text{ \{dimensionless\}})$
 $(0.00, 1.00), (2.50, 0.856), (5.00, 0.687), (7.50, 0.534), (10.0, 0.433), (12.5, 0.374), (15.0,$
 $0.34), (17.5, 0.323), (20.0, 0.315), (22.5, 0.31), (25.0, 0.306)$

Initial Values for the Game

$\text{Init_ADH} = 18000$
 $\text{Init_ADH_Pool} = 425992.06$
 $\text{Init_ALD} = 2931.22$
 $\text{Init_ANH} = 213.17$

Init_ECNa = 1834.44

Init_Gut = 42.75

Init_Renin = 8274.71

Init_TBW = 44985.59

na_intake_times = 1

set_ADH_conc = 8

Renin-ANG-ALD

ALD(t) = ALD(t - dt) + (ALD_adjust) * dt

INIT ALD = Init_ALD

INFLOWS:

ALD_adjust = (desired_ALD-ALD)/ALD_adj_time {ng/h}

ALD_conc_perceived(t) = ALD_conc_perceived(t - dt) + (ALD_correct) * dt

INIT ALD_conc_perceived = ALD_conc {ng/dl}

INFLOWS:

ALD_correct = (ALD_conc-ALD_conc_perceived)/ALD_conc_perceive_del {ng/h}

Renin(t) = Renin(t - dt) + (renin_sec) * dt

INIT Renin = Init_Renin

INFLOWS:

renin_sec = (desired_renin-Renin)/renin_del

ALD_adj_time = 0.5 {h}

ALD_conc = 100*ALD/normal_TBW {ng/dl}

ALD_conc_normal = 8.5

ALD_conc_perceive_del = 0.5

ALD_ratio_to_normal = ALD_conc/ALD_conc_normal {dimensionless}

ANG_conc = 19.95262315*Renin_ratio

desired_ALD = desired_ALD_conc*normal_TBW/100 {ng}

desired_ALD_conc =

ALD_conc_normal*eff_of_ANG_on_ALD*eff_of_ECNa_conc_on_ALD {ng/dl}

desired_renin = desired_renin_activity*normal_ECFV*1000

desired_renin_activity = normal_renin_activity*eff_of_MAP_on_renin {dimensionless}

log_ANG = LOG10(ANG_conc)

normal_renin_activity = 1 {ng/L}

perceived_ALD_ratio = ALD_conc_perceived/ALD_conc_normal

renin_del = 0.25 {h}

Renin_ratio = Renin/normal_ECFV/1000

eff_of_ANG_on_ALD = GRAPH(log_ANG {dimensionless})

(0.00, 0.055), (0.1, 0.11), (0.2, 0.17), (0.3, 0.23), (0.4, 0.29), (0.5, 0.355), (0.6, 0.425), (0.7, 0.49), (0.8, 0.555), (0.9, 0.62), (1, 0.685), (1.10, 0.754), (1.20, 0.85), (1.30, 1.00), (1.40, 1.17), (1.50, 1.67), (1.60, 2.23), (1.70, 2.90), (1.80, 3.75), (1.90, 4.61), (2.00, 5.46), (2.10, 6.51), (2.20, 7.65), (2.30, 8.79)

eff_of_ECNa_conc_on_ALD = GRAPH(ExtracellularNa_conc)

(95.0, 5.28), (98.8, 3.98), (103, 2.98), (106, 2.27), (110, 1.79), (114, 1.49), (118, 1.28), (121, 1.16), (125, 1.08), (129, 1.04), (133, 1.02), (136, 1.01), (140, 1.00)

eff_of_MAP_on_renin = GRAPH(Mean_Arter_Press)

(80.0, 7.58), (83.3, 6.08), (86.7, 4.64), (90.0, 3.38), (93.3, 2.37), (96.7, 1.60), (100.0, 1.00), (103, 0.72), (107, 0.43), (110, 0.265), (113, 0.17), (117, 0.125), (120, 0.09)

Saline Inf.

Sodium_Load_Given(t) = Sodium_Load_Given(t - dt) + (na_in) * dt

INIT Sodium_Load_Given = 0 {mEq}

INFLOWS:

na_in = na_infused {mEq/h}

Water_Load_given(t) = Water_Load_given(t - dt) + (water_in) * dt

INIT Water_Load_given = 0 {ml}

INFLOWS:

water_in = water_infused/1000 {ml/h}

HYPERTONIC_3%_SALINE = 0 {ml/h}

HYPOTONIC_SALINE = 0 {ml/h}

ISOTONIC_SALINE = 0 {ml/h}

na_infused =

(ISOTONIC_SALINE*0.142+HYPOTONIC_SALINE*0.06+HYPERTONIC_3%_SALINE*0.3)/decision_period {mEq/h}

water_infused =

(ISOTONIC_SALINE+HYPERTONIC_3%_SALINE+HYPOTONIC_SALINE)/decision_period {ml/h}

Sodium (Na)

Extracellular_Na(t) = Extracellular_Na(t - dt) + (na_intake + na_infusion -

```

na_out_in_urine) * dt
INIT Extracellular_Na = Init_ECNa {mEq}
INFLOWS:
na_intake = normal_na_intake*na_intake_times {mEq/h}
na_infusion = na_infused {mEq/h}
OUTFLOWS:
na_out_in_urine = na_out*60 {mEq/h}
ECOsm = ExtracellularNa_conc*2.1
ExtracellularNa_conc = Extracellular_Na/Extracellular_Fluid_Vol {mEq/L}
Filtered_Na = Glomerular_Filtr_Rate*ExtracellularNa_conc/1000
IK = 3550{3500}
IK_conc = IK/Intracellular_Fluid_Vol {mEq/L-for verification}
log_ALD_ratio = LOG10(perceived_ALD_ratio) {dimensionless}
na_excr_ratio = na_out_in_urine/normal_na_excr {dimensionless}
na_intake_plus_infusion = na_intake+na_infusion
na_out =
Filtered_Na*normal_fract*eff_of_ANH_on_na_excr*eff_of_diuretic_on_na_excr*
eff_of_ALD_on_na_excr {mEq/min}
normal_fract = 1/142 {dimensionless}
normal_na_excr = 0.125*60 {mEq/hr}
normal_na_intake = 0.125*60 {mEq/h}
pct_chg_ECOsm = (ECOsm-set_point_ECOsm)/set_point_ECOsm*100 {dimensionless}
set_point_ECOsm = 298.2 {mEq/ml}
eff_of_ALD_on_na_excr = GRAPH(log_ALD_ratio {dimensionless})(-1.00, 2.97), (-0.833,
2.84), (-0.667, 2.56), (-0.5, 2.23), (-0.333, 1.79), (-0.167, 1.37), (-1.67e-016, 1.00), (0.167,
0.765), (0.333, 0.54), (0.5, 0.33), (0.667, 0.195), (0.833, 0.09), (1, 0.045)
eff_of_ANH_on_na_excr = GRAPH(ANH_ratio_to_normal {dimensionless})
(0.00, 0.36), (0.0833, 0.363), (0.167, 0.366), (0.25, 0.37), (0.333, 0.38), (0.417, 0.4), (0.5,
0.43), (0.583, 0.477), (0.667, 0.575), (0.75, 0.71), (0.833, 0.88), (0.917, 0.97), (1.00, 1.00),
(1.08, 1.025), (1.17, 1.05)... (9.67, 3.60), (9.75, 3.625), (9.83, 3.65), (9.92, 3.675), (10.0,
3.7)
Urinary Na Conc.
escape = IF(ADH_ratio_to_normal>1)THEN(potential_escape)ELSE(1)

```

$GFR_o = 125 \text{ \{ml/min\}}$
 $implied_UNa_conc = implied_UNa_conc_by_ADH$
 $*eff_of_aquaretic_on_UNa*eff_of_GFR_on_UNa\{mEq/L\}$
 $implied_UNa_conc_by_ADH = Normal_UNa_conc/eff_of_ADH \text{ \{mEq/l\}}$
 $max_att_UNa_conc = max_UNa_conc*eff_of_diuretic_on_UNa*escape \text{ \{mEq/L\}}$
 $max_UNa_conc = 500 \text{ \{mEq/L\}}$
 $min_UNa_conc = 10$
 $Normal_UNa_conc = 125 \text{ \{mEq/L\}}$
 $prc_chg_GFR = (Glomerular_Filtr_Rate-GFR_o)/GFR_o*100 \text{ \{dimensionless\}}$
 $Urinary_Na_conc =$
 $MIN(MAX(min_UNa_conc,(Normal_UNa_conc*eff_of_max_att_UNa_on_UNa+implied_UNa_conc*(1-eff_of_max_att_UNa_on_UNa))),max_UNa_conc)$
 $eff_of_ADH = GRAPH(ADH_ratio_to_normal)$
 $(0.00, 12.0), (0.125, 11.6), (0.25, 10.6), (0.375, 8.46), (0.5, 5.22), (0.625, 2.52), (0.75, 1.38),$
 $(0.875, 1.08), (1.00, 1.00), (1.13, 0.819), (1.25, 0.696), (1.38, 0.61), (1.50, 0.55), (1.63,$
 $0.51), (1.75, 0.48), (1.88, 0.45), (2.00, 0.423), (2.13, 0.397), (2.25, 0.374), (2.38, 0.355),$
 $(2.50, 0.338), (2.63, 0.324), (2.75, 0.311), (2.88, 0.303), (3.00, 0.3)$
 $eff_of_GFR_on_UNa = GRAPH(prc_chg_GFR)$
 $(-9.00, 2.58), (-8.18, 1.90), (-7.36, 1.54), (-6.55, 1.34), (-5.73, 1.22), (-4.91, 1.15), (-4.09,$
 $1.10), (-3.27, 1.07), (-2.45, 1.04), (-1.64, 1.02), (-0.818, 1.01), (1.55e-015, 1.00), (0.818,$
 $0.99), (1.64, 0.97), (2.45, 0.94), (3.27, 0.898), (4.09, 0.853), (4.91, 0.81), (5.73, 0.755),$
 $(6.55, 0.703), (7.36, 0.643), (8.18, 0.595), (9.00, 0.55)$
 $eff_of_max_att_UNa_on_UNa = GRAPH(max_att_UNa_conc/max_UNa_conc$
 $\text{\{dimensionless\}}$
 $(0.4, 1.00), (0.45, 0.985), (0.5, 0.955), (0.55, 0.885), (0.6, 0.78), (0.65, 0.6), (0.7, 0.42),$
 $(0.75, 0.31), (0.8, 0.215), (0.85, 0.143), (0.9, 0.072), (0.95, 0.0276), (1.00, 0.00)$
 $potential_escape = GRAPH(ExtracellularNa_conc \text{ \{dimensionless\}})$
 $(95.0, 0.328), (98.9, 0.507), (103, 0.647), (107, 0.752), (111, 0.815), (115, 0.867), (119,$
 $0.907), (122, 0.932), (126, 0.956), (130, 0.975), (134, 0.99), (138, 0.997), (142, 1.00)$

Not in a sector

$Na_In_Current_Period(t) = Na_In_Current_Period(t - dt) + (na_intake_period-$
 $na_out_period) * dt$
 $INIT Na_In_Current_Period = 0 \text{ \{mEq\}}$

INFLOWS:

na_intake_period = na_intake_plus_infusion

OUTFLOWS:

na_out_period = Na_In_Current_Period*dec_variable_period/DT

Na_Out_Current_Period(t) = Na_Out_Current_Period(t - dt) + (na_lost_period - na_lost_out_period) * dt

INIT Na_Out_Current_Period = 0 {mEq}

INFLOWS:

na_lost_period = na_out_in_urine {mEq/h}

OUTFLOWS:

na_lost_out_period = Na_Out_Current_Period*dec_variable_period/DT {Eq/h}

Total_Change_in_ECNa_conc(t) = Total_Change_in_ECNa_conc(t - dt) + (rate_of_change) * dt

INIT Total_Change_in_ECNa_conc = 0 {mEq/L}

INFLOWS:

rate_of_change = Hourly_ECNa_Correction_Rate {mEq/L/h}

Urine_Output_Current_Period(t) = Urine_Output_Current_Period(t - dt) + (UFlow_in_period - UFlow_out_period) * dt

INIT Urine_Output_Current_Period = 0 {mL}

INFLOWS:

UFlow_in_period = urine_flow__ {ml/h}

OUTFLOWS:

UFlow_out_period = Urine_Output_Current_Period*dec_variable_period/DT {ml/h}

Urine_Period[Dim_Name_1](t) = Urine_Period[Dim_Name_1](t - dt) + (urine_flow[Dim_Name_1]) * dt

INIT Urine_Period[Dim_Name_1] = 0 {ml}

INFLOWS:

urine_flow[1] = IF((TIME>0)AND(TIME<decision_period))THEN(urine_flow__)ELSE(0)
{ml/h}

.....

urine_flow[30] =

IF((TIME>29*decision_period)AND(TIME<30*decision_period))THEN(urine_flow__)
ELSE(0)

```

WaterInPeriod[Dim_Name_1](t) = WaterInPeriod[Dim_Name_1](t - dt) +
(fluid_intake[Dim_Name_1]) * dt
INIT WaterInPeriod[Dim_Name_1] = 0 {ml}
INFLOWS:
fluid_intake[1] =
IF((TIME>0)AND(TIME<decision_period))THEN(water_intake_rate)ELSE(0) {ml/h}
.....
fluid_intake[30] =
IF((TIME>29*decision_period)AND(TIME<30*decision_period))THEN(water_intake_rate)ELSE(0) {ml/h}
Water_Intake_Current_Period(t) = Water_Intake_Current_Period(t - dt) + (water_in_period - water_out_period) * dt
INIT Water_Intake_Current_Period = 0 {ml}
INFLOWS:
water_in_period = (drinking+water_infused) {ml/h}
OUTFLOWS:
water_out_period = Water_Intake_Current_Period*dec_variable_period/DT {ml/h}
Aldosterone_Ratio_to_normal =
IF(MOD(TIME,decision_period)=0)THEN(ALD_ratio_to_normal)ELSE(0)
{dimensionless}
Antidiuretic_Hormone_Ratio_to_normal =
IF(MOD(TIME,decision_period)=0)THEN(ADH_ratio_to_normal)ELSE(0)
{dimensionless}
Atrial_Natriuretic_Hormone_Ratio_to_normal =
IF(MOD(TIME,decision_period)=0)THEN(ANH_ratio_to_normal)ELSE(0)
{dimensionless}
bedside_attendant = Extracellular_Sodium_Concentration\_mEqL
Body_Water\_L =
IF(MOD(TIME,decision_period)=0)THEN(Total_Body_Water)ELSE(0) {L}
cumulative_interval = INT((TIME+1)/decision_period) {dimensionless}
Daily_ECNa_correct = (ABS(Daily_ECNa_Correction_Rate)) {mEq/L/d}
Daily_ECNa_Correction_Rate = (ExtracellularNa_conc-ECNa_conc_daily) {mEq/L/d}
Daily_ECNa_Corr_Lower_Limit = -10 {mEq/L/d}

```

Daily_ECNa_Corr_Upper_Limit = 10 {mEq/L/d}
 Daily_Fluid_Intake = 2000
 decision_period = four_hours*4+eight_hours*8+twelve_hours*12
 dec_variable_period = IF NOT MOD(Time_Stamp,decision_period) THEN 1 ELSE 0
 {dimensionless}
 Drug_Dosage_Given = 20 {mg}
 ECNa_conc_an_hour = DELAY(ExtracellularNa_conc,1) {mEq/L}
 ECNa_conc_daily = DELAY(ExtracellularNa_conc,24) {mEq/L}
 ECNa_correction = ABS(Hourly_ECNa_Correction_Rate) {mEq/L/h}
 eight_hours = 1 {dimensionless}
 Estimated_Insensible_Loss_in_that_Period_L =
 IF(TIME>0)THEN(insensible_loss*decision_period/1000)ELSE(0) {L}
 Extracellular_Fluid_Volume_L =
 IF(MOD(TIME,decision_period)=0)THEN(Extracellular_Fluid_Vol)ELSE(0) {L}
 Extracellular_Sodium_Concentration_mEqL =
 IF(MOD(TIME,decision_period)=0)THEN(ExtracellularNa_conc)ELSE(105) {mEq/L}
 Extracellular_Sodium_mEq =
 IF(MOD(TIME,decision_period)=0)THEN(Extracellular_Na)ELSE(1800) {mEq}
 four_hours = 0 {dimensionless}
 Glomerular_Filtration_Rate_ml\min =
 IF(MOD(TIME,decision_period)=0)THEN(Glomerular_Filtr_Rate)ELSE(0) {ml/min}
 heaven = ExtracellularNa_conc {dimensionless}
 heaven2 = Mean_Arter_Press {dimensionless}
 heaven3 = Total_Body_Water {dimensionless}
 Hourly_ECNa_Correction_Rate = ExtracellularNa_conc-ECNa_conc_an_hour {mEq/L/h}
 Hourly_ECNa_Corr_Lower_Limit = -0.6 {mEq/L/h}
 Hourly_ECNa_Corr_Upper_Limit = 0.6 {mEq/L/h}
 Intracellular_Fluid_Volume_L =
 IF(MOD(TIME,decision_period)=0)THEN(Intracellular_Fluid_Vol)ELSE(0) {L}
 Isotonic_Saline_Infusion_ = 500 {ml}
 Mean_Arterial_Pressure_mmHg =
 IF(MOD(TIME,decision_period)=0)THEN(Mean_Arter_Press)ELSE(0) {mmHg}
 Normal_Body_Water = 40 {L}

```

Normal_ECNa = 2130 {mEq}
Normal_ECNa_conc = 142 {mEq/min}
Normal_GFR = 125 {ml/min}
Normal_ICFV = 25 {L}
Normal_MAP = 100 {mmHg}
Normal_Sodium_Turnover_of_a_Healthy_Person_\_mEq =
normal_na_excr*decision_period {mEq}
normal_UFlow = 1 {ml/min}
Normal_Water_Turnover_of_a_Healthy_Person_\_L = IF(TIME)>0
THEN(((normal_UFlow*60)+insensible_loss)/1000*decision_period)ELSE(0) {L}
pause_variable = IF NOT MOD(Time_Stamp,decision_period) THEN PAUSE ELSE 0
{dimensionless}
rate_of_daily_correct =
IF(MOD(TIME,decision_period)=0)THEN(Daily_ECNa_Correction_Rate)ELSE(0)
{mEq/L/d}
rate_of_hourly_correct =
IF(MOD(TIME,decision_period)=0)THEN(Hourly_ECNa_Correction_Rate)ELSE(0)
{mEq/L/h}
Renin_Ratio_to_normal =
IF(MOD(TIME,decision_period)=0)THEN(Renin_ratio)ELSE(0) {dimensionless}
Sodium_Intake_in_current_Period_\_mEq =
IF(MOD(TIME,(decision_period))=0)THEN(Na_In_Current_Period)ELSE(0) {mEq}
Sodium_Lost_in_Current_Period_\_mEq =
IF(MOD(TIME,decision_period)=0)THEN(Na_Out_Current_Period)ELSE(0) {mEq}
superiors = if ECNa_correction>Hourly_ECNa_Corr_Upper_Limit then 1 else 0
{dimensionless}
superiors2 = Daily_ECNa_correct
superiors3 = Mean_Arterial_Pressure_\_mmHg
superiors4 = Body_Water_\_L
superiors5 = Extracellular_Fluid_Volume_\_L
superiors6 = Extracellular_Sodium_\_mEq
superiors7_ = Intracellular_Fluid_Volume_\_L
Time_Stamp = TIME {h}

```

```
twelve_hours = 0 {dimensionless}
Urinary_Na_Concentration\_mEq\L =
IF(MOD(TIME,decision_period)=0)THEN(Urinary_Na_conc)ELSE(0) {mEq/L}
UrineOut_current_period = Urine_Output_Current_Period/1000 {L}
Urine_Output_in_current_Period\_L =
IF(MOD(TIME,decision_period)=0)THEN(Urine_Output_Current_Period/1000)ELSE(0)
WaterIn_current_period = Water_Intake_Current_Period/1000 {L}
Water_Intake_in_current_Period\_L =
IF(MOD(TIME,decision_period)=0)THEN(Water_Intake_Current_Period/1000)ELSE(0)
water_intake_rate = (water_infused+drinking) {ml/h}
```

APPENDIX D: GLOSSARY

Aldosterone: Aldosterone is a mineralocorticoid, adrenocortical hormone that possesses a high sodium-retaining ability.

Angiotensin: Angiotensin is the most powerful vasoconstrictor agent made by the body, and also the most potent direct stimulus for the release of aldosterone by the zona glomerulosa of the adrenal cortex.

Atrial Natriuretic Hormone (ANH): A hormone that is secreted from the atrial tissue of the heart. ANH causes an increase in electrolyte excretion rates and urine volume.

Antidiuretic Hormone (ADH): A hormone that is secreted by the pituitary gland. ADH is involved in controlling body water and osmolality.

Aquaretic (ADH-Antagonist): A category of drugs that are used in the management of patients with water excess and consequent dilutional hyponatremia.

Diabetes Insipidus/Polyuria: The passage of more than 2 liters of dilute fluid through the body. This condition may be due to the failure of ADH release (hypothalamic DI) or failure of the kidney to respond to ADH (nephrogenic DI).

Diuretic: A category of drugs that are used in the management of body fluid disorders such as edema or hyponatremia.

Diuresis: An increased rate of urine, which can be of two types: water diuresis and solute or osmotic diuresis

Euvolemia: Normal blood volume.

Extracellular Sodium Concentration: Amount of sodium contained in one liter of extracellular fluid, usually expressed as mmol or mEq/L.

Glomerular Filtration Rate (GFR): The GFR is the amount of filtrate formed per minute in all nephrons of both kidneys. In the adult male, this rate is about 125 ml/min; in the female about 110 ml/min.

Hypervolemia: Elevated blood volume.

Hypovolemia: Reduced blood volume.

Molality: The number of moles of a solute per kilogram of solvent

Molarity: The number of moles of solute per liter of solution

Natriuresis: Natriuresis /osmotic diuresis results when more solute is presented to the kidney than they reabsorb. In contrast to water diuresis, urine flow rate depends upon urinary solute content.

Osmolality: The number of osmoles per liter of water (solvent). The osmole is 1 g molecular weight of a nonionizable solute.

Osmolarity: The number of osmoles per liter of solution.

Osmosis: Osmosis is the net diffusion of water across a selectively permeable membrane from a region of high water concentration to one that has a lower water concentration.

Polyuria: See Diabetes Insipidus.

Renin-Angiotensin-Aldosterone System (RAAS): The Renin-Angiotensin-Aldosterone system is one of the most powerful regulators of sodium and potassium balance and arterial blood pressure. These three functions are regulated by changes in Angiotensin and Aldosterone levels in response to wide variations in dietary intake of sodium and potassium.

Renin: Renin is a specific enzyme produced in the kidney, which is stimulated by decreases in blood volume and/or pressure.

Tonicity: The effective osmolality which is equal to the sum of the concentrations of the solutes which have the capacity to exert an osmotic force across the membrane. Tonicity is a term used frequently in a medical context.

Urinary sodium concentration: Amount of sodium contained in one liter of urine, usually expressed as mmol or mEq/L.

Water diuresis: The production of a large volume of a dilute urine which results when water ingested or administered is in excess of body requirements.

REFERENCES

- Abbrecht, P.H., 1980, "Regulation of Extracellular Fluid Volume and Osmolality", *Annals of Biomedical Engineering*, Vol: 8, pp. 461-472.
- Bagby, S.P. and W. M. Bennett, 1998, "Differentiating Disorders of ECF Volume/ Na Content Regulation versus Disorders of Total Body Fluid Osmolarity/ Water Regulation", *Advances in Physiology Education*, Vol. 20, No: 1, pp. 169-184.
- Bankir, L., 2001, "Antidiuretic Action of Vasopressin: Quantitative Aspects and Interaction between V1a and V2 Receptor-Mediated Effects", *Cardiovascular Research*, Vol. 51, pp. 372-390.
- Barlas, Y., 1996, "Formal Aspects of Model Validity and Validation in System Dynamics", *System Dynamics Review*, Vol.12, No.3, pp. 183-210.
- Bray, J.J, P.A. Cragg, and A.D.C. Macknight, 1989, *Lecture Notes on Human Physiology*, Oxford, Boston: Blackwell Scientific Publications; Chicago, Ill.: Distributor, USA, Year Book Medical Publishers, c1989.
- Brandis, K., 2005, "Fluid Physiology - an on-line text"
<http://www.anaesthesiamcq.com/FluidBook/index.php>.
- Bricker, N.S., 1967, "The Control of Sodium Excretion with Normal and Reduced Nephron Populations. The Pre-eminence of Third Factor", *The American Journal of Medicine*, Vol: 43, pp. 313-321.

- Cameron, W. H., 1977, "A Model Framework for Computer Simulation of Overall Renal Function", *Journal of Theoretical Biology*, Vol: 66, pp. 551-572.
- Cannon, W, 1939, *The Wisdom of the Body*, N.Y. Norton.
- Carson, E.R., C. Cobelli and L. Finkelstein, 1983, *The Mathematical Modeling of Metabolic and Endocrine Systems*, New York: Wiley.
- Cogan, E., M.F. Debieve, T. Pepersack, M. Abramov, 1988, "Natriuresis and Atrial Natriuretic Factor Secretion during Inappropriate Antidiuresis", *The American Journal of Medicine*, Vol. 84, pp. 409-418.
- Coleman, T.G. and J. E. Hall, 1992, "A Mathematical Model of Renal Hemodynamics and Excretory Function", in *Structuring Biological Systems- A Computer Modeling Approach*, edited by S. Sitharama Iyengar, CRC Press.
- Cumming, A and W. Plant, 2003, "Water, Electrolyte and Acid-Base Imbalance", In: *Davidson's Principles & Practice of Medicine*, Elsevier Health Sciences.
- Decaux, G., 2001, "Long-term Treatment of Patients with Inappropriate Secretion of Antidiuretic Hormone by the Vasopressin Receptor Antagonist Conivaptan, Urea, or Furosemide", *The American Journal of Medicine*, Vol: 110, No: 7, pp. 582-584.
- DeHaven J.C., Shapiro N.Z., 1967, "On the control of urine formation", *Nephron*, Vol: 4, Suppl 4, pp. 1-63.
- Deshmukh S., C. Thomas, 2005, "Syndrome of Inappropriate Secretion of Antidiuretic Hormone", <http://www.emedicine.com/med/topic3541.htm>

- Ecelbarger, C.A., C. Chou, A. J. Lee, S. R. DiGiovanni, J.G. Verbalis and M. A. Knepper, 1998, "Escape from Vasopressin-Induced Antidiuresis: Role of Vasopressin Resistance of the Collecting Duct", *American Journal of Physiology*, Vol: 274 (6 Pt 2), pp. 1161-1166.
- Edoute, Y., M. R. Davids, C. Johnston and M.L. Halperin, 2003, "An Integrative Physiological Approach to Polyuria and Hyponatremia: a 'double-take' on the Diagnosis and Therapy in a Patient with Schizophrenia", *Q.J. Med*, Vol: 96, pp. 531-540.
- Goh, K.P., 2004, "Management of Hyponatremia", *American Family Physician*, Vol: 69, pp. 2387-2394.
- Guyton, A.C., T.G. Coleman, 1967, "Long Term Regulation of the Circulation: Interrelationships with Body Fluid Volumes". In: *Physical Bases of Circulatory Transport: Regulation and Exchange*, edited by E.B. Reeve, and A.C. Guyton. Philadelphia: W.B. Saunders Company.
- Guyton, A. C., T. G. Coleman, and H. J. Granger, 1972, "Circulation: Overall Regulation", *Annu. Rev. Physiol.* Vol: 34, pp. 13-46.
- Guyton, A. C., T.G. Coleman, D.B. Young, T.E.Lohmeier, and J. W. DeClue, 1980, "Salt Balance and Long-Term Blood Pressure Control", *Ann. Rev. Med.*, Vol: 31, pp. 15-27.
- Guyton, A.C., J.E. Hall., 2000, *Textbook of Medical Physiology*. Philadelphia: W.B. Saunders Company.

- Halperin M.L., 2002, "Body Compartment Volumes and Composition After Giving a Vasopressin Antagonist", *Nephrol Dial Transplant*, Vol: 17, No: 2, pp. 300-303.
- Halperin, M.L and D. Bohn, 2002, "Clinical Approach to Disorders of Salt and Water Balance; Emphasis on Integrative Physiology", *Critical Care Clinics*, Vol: 18, No: 2, pp. 249-272.
- Haslett, C., Chilvers, Boon, E. R., Colledge, N.A., N.R., J.A. Hunter, (eds.), 2003, *Davidson's Principles and Practice of Medicine*, Elsevier Health Sciences.
- Hirshberg, B, A. Ben-Yehuda, 1997, "The Syndrome of Inappropriate Antidiuretic Hormone Secretion in the Elderly", *American Journal of Medicine*, Vol: 103, pp. 270-273.
- Ikeda, N., F. Marumo, M. Shirataka and T. Sato, 1979, "A Model of Overall Regulation of Body Fluids", *Annals of Biomedical Engineering*, Vol: 7, pp. 135-166.
- Ishikawa, S., T. Saito, K. Kasono, 2004, "Pathological Role of Aquaporin-2 in Impaired Water Excretion and Hyponatremia", *Journal of Neuroendocrinology*, Vol: 16, pp. 293-296.
- Jamison, R. L and R.E. Oliver, 1982, "Disorders of Urinary Concentration and Dilution", *The American Journal of Medicine*, Vol: 72, pp. 308-322.
- Janicic N. and J.G. Verbalis, 2003, "Evaluation and Management of Hypo-osmolality in Hospitalized Patients", *Endocrinology and Metabolism Clinics of North America*, Vol: 32, pp.459-481.

- Janssen, W.M.T., 1994, *Atrial Natriuretic Factor- Integrated Effects on Blood Pressure, Natriuresis, and Renal Medullary Blood Flow in Man*, Ph. D. Thesis, Rijksuniversiteit Groningen.
- Karaaslan, F., 2004, *Modeling and Analysis of the Interaction Between Renal Sympathetic Nerve Activity, Arterial Pressure and Sodium Excretion*, PhD Thesis, Bogazici University.
- Kasper, D.L., E. Braunwald, A. Fauci, S. Hauser, D. Longo, J.L. Jameson, 2004, *Harrison's Principles of Internal Medicine*, McGraw-Hill.
- Kaye, M., 1966, "An Investigation into the Cause of Hyponatremia in the Syndrome of Inappropriate Secretion of Antidiuretic Hormone", *The American Journal of Medicine*, Vol: 41, No: 6, pp. 910-926.
- Laragh J.H., 1985, "Atrial Natriuretic Hormone the renin-aldosterone axis, and blood pressure-electrolyte homeostasis", *New England Journal of Medicine*, Vol: 313, No: 21, pp. 1330-1340.
- Navar, L., 1997, "The Kidney in Blood Pressure Regulation and Development of Hypertension", *Medical Clinics of North America*, Vol: 81, No: 5, pp. 1165-1198.
- Northrop, R.B., 2000, "Hormonal Regulation of Sodium, Potassium, Calcium and Magnesium Ions", in: *Endogeneous and Exogeneous Regulation and Control of Physiological Systems*, Boca Raton, Fla.: Chapman & Hall/CRC, c2000.
- Palm, C., D. Reimann and P. Gross, 2001, "The Role of V2 Vasopressin Antagonists in Hyponatremia", *Cardiovascular Research*, Vol. 51, pp. 403-408.

- Reeve, E.B. and L. Kulhanek, 1967, "Regulation of Body Water Content: A Preliminary Analysis", in: *Physical Bases of Circulatory Transport: Regulation and Exchange*, edited by E.B. Reeve, and A.C. Guyton. Philadelphia: W.B. Saunders Company.
- Sagawa, Kiichi, 1975, "Critique of a Large-scale Organ System Model: the Guytonian Cardiovascular Model", *Annals of Biomedical Engineering*, Vol: 3, No: 4, pp. 386-400.
- Saito, T., S. Ishikawa, K. Abe, K. Kamoi, K. Yamada, K. Shimizu, T. Saruta and S. Yoshida, 1996, "Acute Aquaresis by the Nonpeptide Arginine Vasopressin(AVP) Antagonist OPC-31260 Improves Hyponatremia in Patients with Syndrome of *Endocrinology and Metabolism*, Vol. 82, No: 4, pp. 1054-1057.
- Schwartz, W.B., W. Bennett, S. Curelop, F.C. Bartter, 2001, "A Syndrome of Renal Sodium Loss and Hyponatremia Probably Resulting from Inappropriate Secretion of Antidiuretic Hormone", *Journal of the American Society of Nephrology*, Vol: 12, pp.2860-2870, reprinted from *The American Journal of Medicine* Vol: 23 pp. 529-542, 1957.
- Shafiee, M.A.S., D. Bohn, E. J. Hoorn and M. L. Halperin, 2003, "How to Select Optimal Maintenance Intravenous Fluid Therapy", *Q. J. Med.*, Vol. 96, pp. 601-610.
- Schrier, R.W. and M. Niederberger, 1993, "Paradoxes of Body Fluid Volume Regulation in Health and Disease: a Unifying Hypothesis", *West J Med*, Vol. 164, pp. 393-408.
- Smith, P., 1998, "Body Fluid Compartments", http://www.liv.ac.uk/~petesmif/teaching/1bds_mb/notes/fluid/text.htm

- Song, J., X. Hu, O. Khan, Y. Tian, J.G. Verbalis and C. Ecelbarger, 2004, "Increased Blood Pressure, Aldosterone Activity, and Regional Differences in Renal ENaC protein During Vasopressin Escape", *American Journal of Physiology Renal Physiology*, Vol. 287, No: 5, pp. 1076-1083.
- Sonnenblick, M., Y. Friedlander, A.J. Rosin, 1993, "Diuretic Induced Severe Hyponatremia-Review and Analysis of 129 Reported Patients", *Chest*, Vol: 103, No: 2, pp. 601-606.
- Sterman, J.D., 2000, *Business Dynamics: Systems Thinking and Modeling in a Complex World*. McGraw-Hill, Boston.
- Sterns, R.H., 1987, "Severe Symptomatic Hyponatremia: Treatment and Outcome. A Study of 64 Cases", *Annals of Internal Medicine*, Vol: 107, pp. 656-664.
- Strand, F.L., 1983, *Physiology- A Regulatory Systems Approach*, New York: Macmillan.
- Toates, F.M. and K. Oatley, 1970, "Computer Simulation of Thirst and Water Balance", *Medical and Biological Engineering*, Vol: 8, pp.71-87.
- Toates, F.M. and K. Qatley, 1977, "Control of Water Excretion by Antidiuretic Hormone: Some Aspects of Modelling the System", *Medical and Biological Engineering and Computing*, Vol: 15, No: 6, pp.579-588.
- Uttamsingh, R. J., M.S. Leaning, J.A. Bushman, E.R. Carson and L. Finkelstein, 1985, "Mathematical Model of the Human Renal System", *Medical and Biological Engineering and Computing*, Vol: 23, pp. 525-536.

- Verbalis, J.G., M.D. Drutarosky, R.J.Ertel, R.R. Vollmer, 1989, "Adaptive Responses to Sustained Volume Expansion in Hyponatraemic Rats", *The Journal of Endocrinology*, Vol: 122, pp. 421-431.
- Verbalis, J.G., 1992, "Pathogenesis of Hyponatremia in an Experimental Model of the Syndrome of Inappropriate Antidiuresis", *American Journal of Physiology*, Vol: 267, pp. 1617-1625.
- Verbalis, J.G., 1998, "Adaptation to Acute and Chronic Hyponatremia: Implications for Symptomatology, Diagnosis, and Therapy", *Semin. Nephrol*, Vol: 18, No: 1, pp. 3-19.
- Verbalis, J.G., 1998, "Studies of Renal Aquaporin-2 Expression During Renal Escape from Vasopressin-induced Antidiuresis", *Advances in Experimental Medicine and Biology*, Vol: 449, pp. 395-406.
- Verbalis, J.G., 2003, "Disorders of Body Water Homeostasis", *Best Practice & Research Clinical Endocrinology & Metabolism*, Vol. 17, No. 4, pp. 471–503.
- Vieweg, W.V., L.S. Godleski, 1988, "Hyponatremia and Atrial Natriuretic Peptide Secretion in Patients with Vasopressin-induced Antidiuresis", *American Journal of Medicine*, Vol: 85, pp. 594-595.
- Weir, M.R., V.J. Dzau, 1999, "The Renin-Angiotensin-Aldosterone System: a Specific Target for Hypertension Management", *American Journal of Hypertension*, Vol: 12, pp. 205-213.
- Wong, L.L. and J.G. Verbalis, 2001, "Vasopressin V2 Receptor Antagonists", *Cardiovascular Research*, Vol. 51, No: 3, pp. 391-402.

Wong, L.L. and J.G. Verbalis, 2002, "Systemic Diseases Associated with Disorders of Water Homeostasis", *Endocrinology and Metabolism Clinics of North America*, Vol: 31, No: 1, pp. 121-140.

Yamamura Y., Ogawa H., Chihara T., Kondo K., Onogawa T., Nakamura S., Mori T., Tominaga M. and Yabuuchi Y., 1991, "OPC-21268, an Orally Effective, Nonpeptide Vasopressin V1 Receptor Antagonist", *Science*, Vol. 252, pp. 572-574.

Yamamura Y., Ogawa H., Yamashita H., Chihara T., Miyamoto H., Nakamura S., Onogawa T., Yamashita T., Hosokawa T., Mori T., Tominaga M. and Yabuuchi Y., 1992, "Characterization of a Novel Aquaretic Agent, OPC-31260, as an Orally Effective, Nonpeptide Vasopressin V2 Receptor Antagonist", *Br J Pharmacol* Vol. 105, pp. 787-791.

Yamamura, Y., A. Ohnishi, R. Okahara, H. Fujihara, T. Inoue, Y. Yabuuchi, T. Tanaka, 1993, "Potent Aquaretic Agent. A Novel Nonpeptide Selective Vasopressin 2 Antagonist (OPC-31260) in Men", *J. Clin. Invest*, Vol: 92, pp. 2653-2659.

Yamasaki, Y., T. Nishiuchi, A. Kojima, H. Saito, 1988, "Effects of an Oral Water Load and Intravenous Administration of Isotonic Glucose, Hypertonic Saline, Mannitol and Furosemide on the Release of Atrial Natriuretic Peptide in Men", *Acta Endocrinologica*, Vol: 119, pp. 269-276.

Zerbe, R. and G. Robertson, 1980, "Vasopressin Function in the Syndrome of Inappropriate Antidiuresis", *Annual Review of Medicine*, Vol: 31, pp. 315-327.

REFERENCES NOT CITED

- Abraham W.T. and R.W. Schrier, 1994, "Body Fluid Volume Regulation in Health and Disease", *Advances in Internal Medicine*, Vol: 39, pp. 23-47.
- Akay, M. and A. Marsh (ed.s), 2001, *Information Technologies in Medicine, Volume 1, Medical Simulation and Education*, Wiley- IEEE Computer Society PR.
- Al-Salman, J., D. Kemp and D. Randall, 2002, "Hyponatremia", *The Western Journal of Medicine*, Vol: 176, pp. 173-176.
- Baylis, 2003, "The Syndrome of Inappropriate Antidiuretic Hormone Secretion", *The International Journal of Biochemistry & Cell Biolog*, Vol: 35, No: 11, pp. 1495-1499.
- Beuter, A., L. Glass, M.C. Mackey, M.S. Titcombe (ed.s), 2003, *Nonlinear Dynamics in Physiology and Medicine (Interdisciplinary Applied Mathematics, V.25)*. Springer Verlag.
- Bigelow, J.H, J.C. DeHaven and M.L. Shapley, 1973, "Systems Analysis of the Renal Function", *Journal of Theoretical Biology*, Vol: 41, pp. 287-322.
- Bookallil, R., 2002, "Sodium Abnormalities in the Neurosurgical Patient", *Current Anaesthesia & Critical Care*, Vol: 13, No: 3, pp. 153-158.
- Brown, J.H.U. and D. S. Gann, (ed.s), 1973, *Engineering Principles in Physiology*, Academic Press, New York and London.

- Carson, E. and C. Cobelli, 2000, *Modeling Methodology for Physiology and Medicine (Academic Press Biomedical Engineering Series)*, Academic Press.
- Davids, M. R., Y. Edoute, J.P. Mallie, D. G. Bichet and M.L. Halperin, 2002, "Body Compartment Volumes and Composition after Giving a Vasopressin Antagonist: Changes are Revealed by a Tonicity Balance", *Nephrol Dial Transplant*, Vol: 17, pp. 300-303.
- Decaux, G., 2001, "Difference in Solute Excretion during Correction of Hyponatremic Patients with Cirrhosis or Syndrome of Inappropriate Secretion of Antidiuretic Hormone by Oral Vasopressin V2 Receptor Antagonist VPA-985", *J Lab Clin Med.*, Vol. 138, No: 1, pp.18-21.
- Flood, R. L., 1985, *Quantitative Modelling of the Fluid-Electrolyte, Acid-Base Balance for Clinical Application*, Ph. D. Thesis , The City University, Department of Systems Science.
- Ford, A., 1999, *Modeling the Environment: An Introduction to System Dynamics Modeling of Environmental Systems*, Island Press, Washington.
- Granger, J.P., 1998, "Regulation of Extracellular Fluid Volume by Integrated Control of Sodium Excretion", *Advances in Physiology Education*, Vol: 275, pp. 157-168.
- Gross, P., D. Reimann, J. Neidel, C. Doke, F. Prospert, G. Decaux, J. Verbalis, R.W. Schrier, 1998, "The Treatment of Severe Hyponatremia", *Kidney International Supplement*, Vol: 64, pp. 6-11.
- Guyton, A.C., 1991, "Blood Pressure Control-Special Role of the Kidneys and Body Fluids", *Science*, Vol: 252, pp. 1813-1816.

- Hall, J.E, Guyton, A.C., and M.W. Brands, 1996, "Pressure-Volume Regulation in Hypertension", *Kidney International*, Vol: 49, Suppl. 55, pp. 35-41
- Hargrove, J.L., 1998, *Dynamic Modeling in the Health Sciences (Modeling Dynamic Systems)*, Springer Verlag.
- Kawai, N., A. Baba, T. Suzuki and H. Shiraishi, 2001, "Roles of Arginine Vasopressin and Atrial Natriuretic Peptide in Polydipsia-Hyponatremia of Schizophrenic Patients", *Psychiatry Research*, Vol. 101, pp. 39-45.
- Keener, J., J. Sneyd, 1998, *Mathematical Physiology*, Springer-Verlag.
- Khoo, M.C.K., *Physiological Control Systems: Analysis, Simulation, and Estimation*, Wiley-IEEE Press.
- Kimura, T., K. Abe, K. Omata, M. Shoji, K. Kudo, K. Matsui, M. Inoue, M. Yasujima, K. Yoshinaga, 1986, "Effects of Acute Water Load, Hypertonic Saline Infusion, and Furosemide Administration on Atrial Natriuretic Peptide and Vasopressin Release in Humans", *The Journal of Clinical Endocrinology and Metabolism*, Vol: 62, pp. 1003-1010.
- Khoo, M.C.K., 1999, *Physiological Control Systems: Analysis, Simulation, and Estimation*. Wiley-IEEE Computer Society Pr.,
- Kofranek, J., L.D.Vu, H. Snaselova, R. Kerekes, T. Velan, 2001, "GOLEM—multimedia simulator for medical education", *Medinfo*, Vol. 10, No: 2, pp. 1042-1046.
- Lawrence J. Goldstein and E. B. Rypins, 1992, "A Computer Model of the Kidney", *Computer Methods and Programs in Biomedicine*, Vol: 37, No: 3, pp. 191-203.

- Leaning M.S., R.L. Flood, D.G. Cramp, E.R. Carson, 1985, "A System of Models for Fluid-Electrolyte Dynamics", *IEEE Trans Biomed Eng.*, Vol: 32, No: 10, pp. 856-864.
- Minhtri K. Nguyen, Ira Kurtz, 2003, "A New Quantitative Approach to the Treatment of Dysnatremias", *Clin Exp Nephrology*, Vol: 7, No: 2, pp.125-137.
- Petra c.m. Donati-Genet, 2001, "Acute Symptomatic Hyponatremia and Cerebral Salt Wasting After", *Journal of Pediatric Surgery*, Vol: 36, No: 7, pp. 1094-1097.
- Richards, A.M., H. Ikram, T.G. Yandle, M.G. Nicholls, M.W.I. Webster, E.A. Espiner, 1985, "Renal, Haemodynamic, and Hormonal Effects of Human Alpha Atrial Natriuretic Peptide in Healthy Volunteers", *The Lancet*, Vol: 1, pp.545-549.
- Rideout, V.C, 1991, *Mathematical and Computer Modeling of Physiological Systems*, Englewood Cliffs, N.J.: Prentice Hall.
- Riggs, D.S, 1970, *Control Theory and Physiological Feedback Mechanisms*, Baltimore: Williams and Wilkins.
- Roman, R. J. and F. R. Sias, 1985, "Network Computer Analysis of the Human Kidney", *Mathematical Modelling*, Vol: 7, pp. 1045-1069.
- Sagnella, G.A., A. C. Shore, N. D. Markandu, G.A. MacGregor, 1985, "Effects of Changes in Dietary Sodium Intake and Saline Infusion on Immunoreactive Atrial Natriuretic Peptide in Human Plasma", *The Lancet*, Vol: 2, pp. 1208-1210.
- Shindel, A., G. Tobin, C. Klutke, 2002, "Hyponatremia Associated with Desmopressin for the Treatment of Nocturnal Polyuria", *Urology*, Vol: 60, No: 2, pp. 344.

- Shimizu, K., 1995, "Aquaretic Effects of the Nonpeptide V2 Antagonist OPC-31260 in Hydropenic Humans", *Kidney International*, Vol: 48, pp. 220-226.
- Sodeman, W., and T.M. Sodeman, 1985, *Sodeman's Pathologic Physiology*, Philadelphia: W.B. Saunders Co., Washington.
- Suzuki, 2002, "Roles of Arginine Vasopressin and Atrial natriuretic peptide in polydipsia-hyponatremia of schizophrenic patients", *Psychiatry Research*, Vol: 101, No: 1, pp.39-45.
- Yamamura Y., S. Nakamura, S. Itoh, T. Hirano, T. Onogawa, T. Yamashita, Y. Yamada, K. Tsujimae, M. Aoyama, K. Kotosai, H. Ogawa, H. Yamashita, K. Kondo, M. Tominaga, G. Tsujimoto and T. Mori, 1998, "OPC-41061, a Highly Potent Human Vasopressin V2-Receptor Antagonist: Pharmacological Profile and Aquaretic Effect by Single and Multiple Oral Dosing in Rats", *The Journal of Pharmacology and Experimental Therapeutics*, Vol: 287, pp. 860-867.