

DEFINING THE CONCEPT OF MECHANISM ON COMPUTATIONALITY

DENİZ İLYAS ŞENER

BOĞAZIÇI UNIVERSITY

2019

DEFINING THE CONCEPT OF MECHANISM ON COMPUTATIONALITY

Thesis submitted to the
Institute for Graduate Studies in Social Sciences
in partial fulfillment of the requirements for the degree of

Master of Arts

in

Philosophy

by

Deniz İlyas Şener

Boğaziçi University

2019

DECLARATION OF ORIGINALITY

I, Deniz İlyas Şener, certify that

- I am the sole author of this thesis and that I have fully acknowledged and documented in my thesis all sources of ideas and words, including digital resources, which have been produced or published by another person or institution;
- this thesis contains no material that has been submitted or accepted for a degree or diploma in any other educational institution;
- this is a true copy of the thesis approved by my advisor and thesis committee at Boğaziçi University, including final revisions required by them.

Signature

Date20 September 2019.....

ABSTRACT

Defining the Concept of Mechanism on Computationality

The new mechanism trend in the twenty-first century philosophy of science, which deals with the special sciences in providing scientific explanations, depends centrally on the concept of mechanism, yet the lack of a rigorous definition of mechanism hampers both further conceptual progress and also interest or conceived utility by the scientific community. Perhaps worse than this, although much subsequent debate and detailed analysis are invested in the discourse of mechanism, things get blurred and diverge instead of heading toward a desired clarity and a minimal but reasonable consensus. In order to help us out of this situation, I offer a mathematical approach by exploiting the well-established mathematical abstraction of the *Turing Machine*. However, such a move inevitably brings to the table the broader philosophical question of the unreasonable effectiveness of mathematics, that is, the successful deployment of mathematics -a deductive system which, as a grand tautology, merely repeats its axioms and is only trivially and analytically true- in representing the physical reality. To counter both challenges in a new breath, the concept of computation has been construed, in the light of recent interpretations, in a suitable way as to accommodate the elucidation of the concept of mechanism.

ÖZET

Mekanikçilik Kavramının Bilgisayım Üzerinden Yeniden Kurulması

21. Yüzyıl felsefesinde ortaya çıkan ve bilimsel açıklama konusunda daha çok özel bilimlere hedefleyen yeni mekanikçilik akımının merkezinde mekanizma kavramı bulunmakla birlikte, bu kavramın kesin bir tanımının hala yapılamamış olması hem bu alanda kavramsal ilerlemeleri tökezletmekte hem de bilim camiasının ilgisini ve bundan herhangi bir yarar beklemesini sağlayamamaktadır. Ancak belki de bundan daha kötüsü, mekanikçilik alanında, ortaya atıldığından bu yana yoğun tartışmalar ve ayrıntılı analizler yapılmasına karşın bazı konuların bulanıklaşması, ve terimin açıklığa kavuşarak minimal da olsa bir uzlaşma sağlanacağı yerde giderek dağılmasıdır. Bu nedenle, bu çalışmada, Batı geleneğinde tercih edilen ve yüksek değer atfedilen matematiksel yaklaşım çerçevesinde, günümüzde genel kabul görmüş matematiksel bir soyutlama olan *Turing Makinesi* üzerinden mekanizma kavramına rasyonel bir tanım önerilmekte. Ancak bu strateji kaçınılmaz olarak matematiğin akıl almaz ölçüdeki etkinliği ifadesiyle ortaya konan, onun gerçekliği nasıl olup da başarıyla temsil edebildiği gibi daha büyük felsefi bir sorunun gündeme gelmesine neden olacaktır; çünkü dedüktif dev bir sistem olarak matematik, özünde bir totoloji silsilesi olması nedeniyle üzerine kurulduğu aksiyomlarını yinelemekten öteye gidememekte ve bize yalnızca sıradan ve analitik bir şekilde doğruluk sunabilmektedir. Bu iki sorunsala ortak yeni bir çözüm olarak, bilgisayarım kavramını, bu alandaki son yorumların ışığında, mekanikçilik kavramının aydınlatılmasına yardımcı olacak şekilde yeniden yorumlamaya çalıştım.

TABLE OF CONTENTS

CHAPTER 1: THE NEW MECHANISM.....	1
1.1 History and classification.....	1
1.2 Criticisms, problems.....	8
CHAPTER 2: WHAT IS A MACHINE (MECHANISM)?.....	13
2.1 Interlude.....	13
2.2 Gandy Machine.....	14
2.3 A break: The historical context.....	20
2.4 Kripke’s project.....	22
CHAPTER 3: MACHINATION, COMPUTATION.....	26
3.1 The correspondence between the two realms.....	26
3.2 Examples.....	34
3.3 The practical minimality criterion: Constrain it to molecular and systems biology.....	36
3.4 Cardelli and the state-of-the-art of systems biology.....	37
3.5 Benefits: Allowing modularity and representation of capacities.....	38
3.6 Epilogue: Is this science or philosophy?	38
REFERENCES.....	40

LIST OF FIGURES

Figure 1. Timeline and grouping of mechanistic approaches within the last 50 years.....	4
Figure 2. Robin Gandy's project.....	15
Figure 3. The unit of machination: mechos.....	29
Figure 4. Two level correspondence between computation and machination.....	32
Figure 5. The functional model of a car subsystem	34
Figure 6. The computational (network) model of some disease progression	35

CHAPTER 1

THE NEW MECHANISM

1.1 History and classification

As a universally applicable concept which contrasts with laws of nature, (and seemingly not suffering from some of their much criticized shortcomings), mechanism has been hailed as the basis of a powerful explanatory framework within philosophy of science, especially suited for special sciences. In that regard, historically, much stimulus came from molecular and systems biology at the end of the twentieth century. This sporadic and mostly explorative early stage helped accumulate momentum for the succeeding more “centralized” promotion of broader generality with the publication of the seminal philosophy of science paper by Machamer, Darden, and Craver (MDC, 2000). When it came to give a more systematic account to the loosely used –and tacitly understood– concept of mechanism, however, philosophers and scientists have been differing in their approach. Varying suggestions, definitions or perspectives were equally in currency during both these early and later stages.

The mechanistic approach is encountered across several disciplines. In some “special sciences”, in systems and structural biology in particular, and, in philosophy of biology in general, this approach was quite explicit and direct. In cognitive science, as inherited from philosophy of mind, the mechanistic outlook was called *computationalism* (in its disguised form) as manifest in the early incarnations of computationalism/functionalism with a foundational reference to *Turing Machines*.

In economics, the concept of mechanism was elucidated, although by a few researchers such as Judea Pearl (2000) and James Woodward (2003), along an underlying and widely used concept which goes by the name of *Structural Equational Model (SEM)*, or sometimes also called causal models. On the other hand, in sociology, even only in its analytical school, this approach is plainly called social mechanism (Hedström & Swedberg, 1996).

Retrospectively, several classificatory attempts have been made in order to precisify a concept of mechanism. Classification criteria also exhibit, understandably, divergence. What is problematic, however, is that sometimes the same theorists are listed under different and conflicting categories.

Stuart Glennan (2010), for example, is content with two main categories where he claims that mechanisms as defended by Wesley Salmon and Peter Railton are based on a process abstraction, whereas the approach used by Bechtel, Glennan himself and MDC falls under the system interpretation of mechanisms. Using a pragmatic criterion to assess the theorists, Arnon Levy (2013) categorizes mechanistic theorists under causal (Glennan), explanatory (MDC) and strategic (Bechtel) varieties; but two years later, in a joint paper with Bechtel (2013), they give only two categories: the first is the line of MDC who “emphasize completeness and specificity”, as an explanatory virtue or ‘regulative ideal’ for mechanistic explanation; and the second line of Bechtel and company, stating merely that they “have not evinced this attitude”.

A more recent summary is given by Beate Krickel (2018, p. 17) where she loosely names Wesley Salmon, Phil Dowe and Peter Railton as “Early Approaches to mechanisms and mechanistic explanation”; labels contributions of Stuart Glennan,

Nancy Cartwright, William Bechtel as “Complex System Approaches to mechanisms”; and finally calls MDC, Craver, and the Phyllis Illari / Jon Williamson duo as defenders of the “Acting Entities Approaches to mechanism”. The interesting point is her claim that “[a]ccording to these approaches, mechanisms are not objects but process-like in the sense that they consist of actual manifestations of activities by various entities that causally interact”. Note that, her including MDC in the process camp is definitely in contrast to Glennan’s interpretation where MDC is listed under the system category.

Glennan and Illari (2018) briefly mention in their recent anthology *The Routledge Handbook of Mechanisms and Mechanical Philosophy* other taxonomical efforts, for example, by H. Andersen, D.J. Nicholson and J. Kuorikoski, after having discussed in a principled way the criteria that would support and justify such categorizing efforts. I do not concur on their observation that taxonomic efforts are necessarily based, primarily, on the varieties of the two constituents (entities, or, activities and interactions); since these concepts themselves are differently interpreted by the authors, it would be inappropriate to use them as such for a categorization on their views on mechanism. Indeed, the classificatory examples I gave above are very sensitive to the task of definition of the constituents and diverge considerably (in addition to the very motivations of the theorists). On the other hand, I am sympathetic to their opinion that “[i]n particular, these accounts suppose a clear univocal conception of what a machine is, but machines themselves are massive in their variety” (Glennan & Illari, 2018, p. 101), and I will elaborate on the concept of a machine in the next chapter.

What are the “constituents” themselves that have to be agreed upon in the first place? And how could their variations possibly determine a better classification of the mechanistic approach of the last 50 years? In Fig. 1, I give, first, a timeline of the active

periods of the theorists on their mechanism related work that have been grouped (A-D) according to the criteria I explain below.

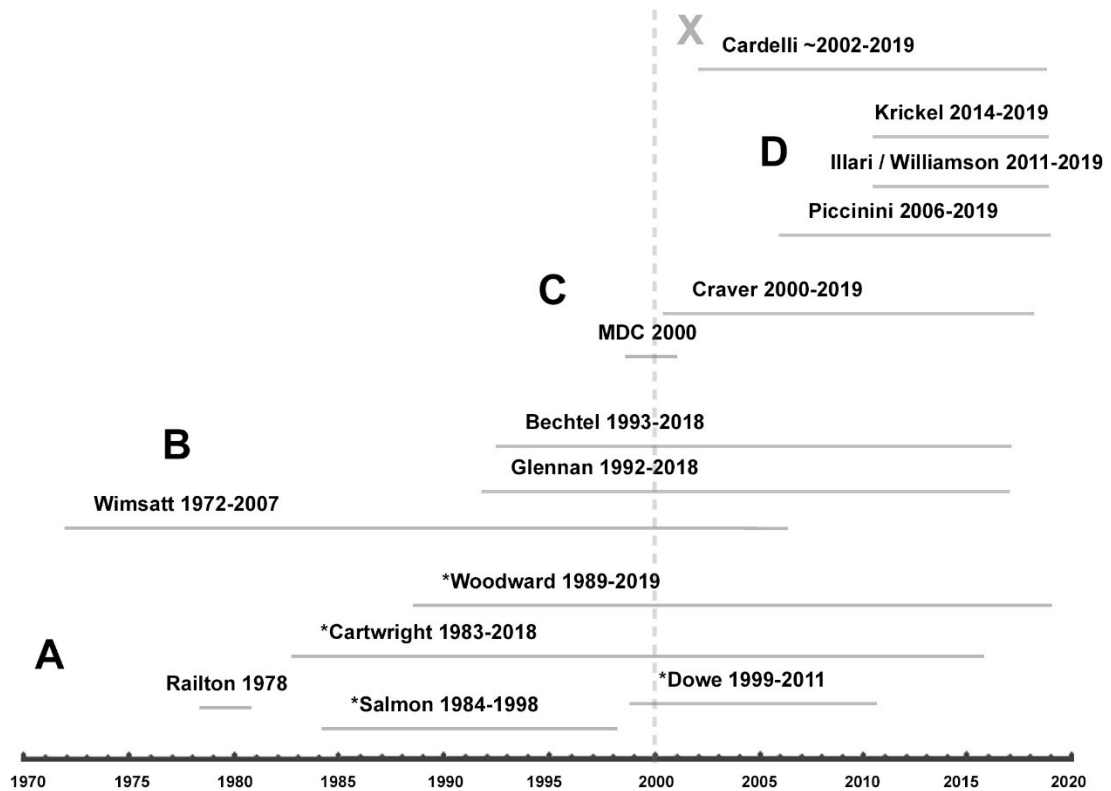

Fig. 1 Timeline and grouping of mechanistic approaches within the last 50 years

The Group A are mostly philosophers of science who are in search of an alternative to Hempel’s Deductive-Nomological model of scientific explanation; as such, their efforts and suggestions are deeply intertwined with the nature and role of causality (Hempel’s model was criticized as lacking any causal explanans).

The next Group B was under the influence of philosopher of biology William C. Wimsatt, the group’s “leader”, but certainly they were also a product of an era when molecular and systems biology studies gained a considerable momentum in those years. But apart from the biological discipline that brought them together, they pursued

different agendas as the breadth of biological research back then was offering vast uncharted waters to be explored.

An interim consolidation was rife to emerge, and this opportunity was exploited by the trio (Group C) of Peter Machamer, Lindley Darden and Carl Craver (MDC) in 2000 with the publication of their seminal paper “Thinking About Mechanisms”. Since then, Craver enthusiastically cooperates with the successors and elaborators of this new endeavor in several directions.

The latest and most recent Group D is one with both a divergent drive to further explore various aspects of the new endeavor, and, at the same time, a common goal to give a more satisfactory answer to the long-lasting problem of a core definition of mechanism. Gualtiero Piccinini takes seemingly a reversed route and is after explaining physical computation in terms of a mechanistic account. Illari and Williamson stay close to the central intertwined problem of causality, but also act as an intermediary post between several players (reminiscent of Antoine Arnauld’s role in Descartes’ times). They also have their own definition of mechanism which seems to be, understandably, a rendition of their vast experience with the literature and players. Finally, Beate Krickel seems to be taking advantage of her position as a latecomer who has developed in her detailed doctoral dissertation an overview of the agenda and thus tries to act as a consolidator, too.

This depiction of the mechanistic scene has some further peculiarities.

First, at the upper corner, there stands a maverick, one-man Group X represented by Luca Cardelli, an extremely prominent computer scientist-turned-systems biologist who has been leading the field, computationally, with some other pioneers of that discipline. He, and the other members of his group, have apparently no direct intellectual

connection with the groups given above (neither do they address the mechanistic philosophy community in their works, nor the community mentions them as the most exemplary practitioners of their theories). In the last chapter, I will briefly examine their efforts and abstractions (which unfortunately include no clues to the current philosophical debates) in the light of this thesis.

Second, mechanistic approaches in major social sciences (economics and analytical sociology) are not shown in the diagram as their definitions of mechanism and uses of the mechanistic approach seem to have been developing quite independently from the philosophical debates and only contacting it sporadically and in a tangential way, if ever.

Finally, I give briefly several definitions, in historical order, (both from others and those cited as members of the above groups) without examining them here further, just to serve as a raw material foundation when offering my own approach to the definition and explication of mechanisms.

A machine is a composite of interrelated parts, each performing its own functions, that are combined in such a way that each contributes to producing a behavior of the system. A mechanistic explanation identifies these parts and their organization, showing how the behavior of the machine is a consequence of the parts and their organization (Bechtel & Richardson, 1993).

A mechanism underlying a behavior is a complex system which produces that behavior by the interaction of a number of parts according to direct causal laws (Glennan, 1996, p. 5).

Mechanisms are entities and activities organized such that they are productive of regular changes from start or set-up to finish or termination conditions (Machamer, Darden & Craver 2000, p. 3).

Mechanisms consist of parts, the behavior of which conforms to generalizations that are invariant under interventions, and which are modular

in the sense that it is possible in principle to change the behavior of one part independently of the others. A mechanism underlying a behavior is a complex system which produces that behavior by the interaction of a number of parts according to direct causal laws (Woodward, 2002, p. S366).

A mechanism for a behavior is a complex system that produces that behavior by the interaction of a number of parts, where the interactions between parts can be characterized by direct, invariant, change-relating generalizations (Glennan 2002b, p. S344).

A mechanism is a structure performing a function in virtue of its component parts, component operations, and their organization. The orchestrated functioning of the mechanism is responsible for one or more phenomena (Bechtel & Abrahamsen 2005, p. 423).

Roughly, a mechanistic explanation involves a partition of a mechanism into parts, an assignment of functions and organization to those parts, and a statement that a mechanism's capacities are due to the way the parts and their functions are organized (Piccinini, 2007, p. 502).

Our favoured characterisation is a synthesis of the views of the main contenders.

‘A mechanism for a phenomenon consists of entities and activities organized in such a way that they are responsible for the phenomenon.’ (Illari & Williamson, 2011, p. 5).

... mechanisms are composed of entities and occurrents (Krickel, 2018, p. 70).

To give examples of social mechanisms used in analytical sociology, I will quote solely from Peter Hedström and Richard Swedberg (1996).

[Merton1968] Merton defined social mechanisms as ‘social processes having designated consequences for designated parts of the social structure’, and argued that it was the main task of sociology to ‘identify’ mechanisms and to establish under which conditions they ‘come into being’, ‘fail to operate’ and so on (Merton 1968:43-44) (Hedström & Swedberg, 1996, p. 283).

[Elster1989] While in Nuts and Bolts Elster says that mechanisms imply ‘explanations of ever finer grain’, in a later work he maintains that

mechanisms, as opposed to laws, only have limited generality (Elster 1989:7; cf. Elster 1991:7-8) (Hedström & Swedberg, 1996, p. 283).

[Stinchcombe1991] Mechanisms in a theory are defined here as bits of theory about entities at a different level (e.g. individuals) than the main entities being theorized about (e.g. groups), which serve to make the higher-level theory more supple, more accurate, or more general (Hedström & Swedberg, 1996, p. 283).

[Schelling1998] A social mechanism is a plausible hypothesis, or set of plausible hypotheses, that could be the explanation of some social phenomena, the explanation being in terms of interactions between individuals, or individuals and some social aggregate (Hedström & Swedberg, 1996, p. 22).

[Gambetta1998] [Mechanisms are] hypothetical causal models which make sense of *individual* behaviour [and] have the form 'given certain conditions K , an agent will do x because of [mechanism] M with probability p (Hedström & Swedberg, 1996, p. 22).

1.2 Criticisms, problems

Similar to the divergence in the definitions of, approaches to, and methodologies for mechanism, criticism of it is also rich in terms of mechanism's very utility, adequacy and functionality. On the other hand, apart from the internal debates of the new mechanists as to what the proper definition, methodological significance, etc. should be, there are also some "external" criticisms, mostly initiated by practicing scientists. Provided that such efforts do not exclusively deny the utility of the new mechanistic approach, they may help correct and improve the claims, contents and understanding.

These criticisms, which are not necessarily mutually exclusive may therefore exhibit a continuum and can be summarized under the following rubrics.

Inside of philosophy of science circles:

- Partial disagreement on the way specific characteristics of the constituents are given (the contents and operational impact of the otherwise accepted constituents are interpreted differently),
- Disagreement on the definition of mechanisms,
- Relation to other means of scientific explanation such as appeal to laws of nature,
- The viability or the merits of the mechanistic approach as a scientific explanation at all.

The efforts of the first group are more of a constructive nature and therefore directed mostly to improvements and modifications. Their criticism is raised because of somewhat similar concerns of those held by the second group; essentially, a pursuit of a proper and effective definition of mechanisms.

The second group among those mentioned above is the largest. As it is the norm in the scientific research community, the internal debate within the mechanistic movement as what constitutes or defines a mechanism is an activity where a party usually defends their theses in their own terms only after having criticized a specific approach or all other alternatives. However, such activities are mostly not proceeding in an incrementally contributing way as they rather start exclusively from scratch, the discipline ends up with a series of competing alternatives all of them on equal standing. The small sample of definitions of mechanism given in the previous section may give an idea about the spread of this endeavor.

Alternatively, as given in the commentary below, the complaints about the abundance and a lack of consensus on the definition of mechanisms are interpreted constructively and claimed to be forming a continuum:

Neo-mechanists thus dwell on different kinds of activities and entities, different types of mechanisms, and a variety of causal claims “Mechanistic diversity” is at stake: instead of sharp distinctions between mechanisms and nonmechanisms, we seem to be facing a sort of continuum, along which different cases can be more or less paradigmatic of a mechanism—or, rather, marginal—according to a set of parameters (Boniolo & Campaner, 2018, p.23).

Since a mechanistic ensemble consists of the articulation of one or more *causal units*¹ where the constituency (physical or abstract), type of structure (particular configuration, feedback loops, etc.), population size (of the units) and their interaction timing (synchronicity/asynchronicity resulting in deterministic/stochastic modes) differ from one case to another, it is quite normal that mechanisms come in different varieties reflecting this richness of classifications. Consequently, provided that a minimal commonality can be established to posit a core definition, differing views of relatively minor relevance can be further specified around this core as to accommodate divergent cases. Only then the pluralism of mechanistic explanations/definitions becomes justified.

For the third group, the nature of applicability and the utility of the mechanistic approach has priority before settling down on the details of what constitutes a mechanism.

Being the most radical, the last group (of philosophers of science) rejects the idea that mechanism offers a viable alternative for explanations in special sciences.

¹ if the use of the concept of causality sounds problematic, a less baggage-laden term such as *interactive units* may be employed instead

Outside of philosophy circles, there is controversy on:

- whether or not philosophical accounts of mechanism actually overlap with the pragmatic or instrumental use of mechanical explanations by the practicing scientists themselves,
- whether or not philosophical accounts of mechanism contribute to the scientific practice.

Here, the first group of “insiders” of the scientific practice may indeed accept a helping hand from philosophers, but they think what the latter have offered so far does not fit the bill. A typical example would be Lenny Moss’ claims:

Rather [...] than grasping and elucidating the situated aims and practices of biologists themselves, the philosophical investigation of the contemporary meaning of mechanism in biology has been commandeered by the needs of ‘hard naturalists’ to replace the old deductive-nomological model of the ‘received view’ with a new normative-explanatory gold-standard.

...

Nowhere in the textbooks, in the pedagogy or in the published research literature of the life sciences is there a place where efforts are made to define the necessary and/or sufficient conditions for what counts as a ‘mechanism’ and yet it is a term that is used freely in the biological research environment. (Moss, 2012, p164)

Indeed, the first part of Moss’ criticism can be attributed to the second group, too. It is true that, in the shadow of the deductive-nomological model of Hempel, this issue is, for philosophers of science, part of an in-house discussion (the validity and extension of Hempel’s model, the status of laws of nature, the structure of scientific explanations, etc. are major constituents of this ongoing debate; the new mechanistic approach is simply the latest contender in this process). The more radical attitude of some scientists representing this second group is that philosophical musings are simply futile and they

consider such activities as internal self-gratifying efforts of philosophers. This view does not do justice, however, at least, to the historical account of scientific developments that were actually accompanied mostly by philosophical scrutiny. On the other hand, on a different reading, it is also true that mechanistic philosophers “sanction” the recent practices of biology as “genuine science” because biology traditionally has not been complying with the norms of the received view of the Hempel’s model.

Laura Franklin-Hall, however, a philosopher of science with a BS in biology, therefore someone as an observer from both perspectives, has an interesting evaluation of the situation which she puts very succinctly:

Neomechanists have largely stated that they are concerned with the sciences as they are actually practised: when addressing mechanistic explanation, they should thus not explain “how things work” in the natural realm, but rather “how things work” when scientists themselves show “how things work”.

...

Perhaps this results from a too-successful enculturation of philosophers into the scientific mindset, making it difficult to achieve the critical distance needed to philosophize *about* science. (Franklin-Hall, 2016, p. 70).

I will consider Franklin-Hall’s opinion in detail in the last section of the thesis.

CHAPTER 2

WHAT IS A MACHINE (MECHANISM)?

2.1 Interlude

Before proceeding to the elaboration of the thesis, it would be useful to state its objective once more.

The new mechanism is hailed as providing a scientific explanation framework alternative to Hempel's Deductive-Nomological model, at least, for special sciences as evinced by the accumulating scientific practice of the last decades. However, the criticisms given above indicate that the philosophical offerings do not seem to be delivering what is expected from them.

As witnessed also by the sometimes conflicting variety of the mechanistic approaches given in the previous chapter, it may be more productive to give, in the first place, the criteria for defining the concept itself. Assuming such a strategy, it follows, then, that one of the central criteria will be a commitment to the elimination of the above explained problem of the ineffective abundance of definitions of mechanism. And proceeding in this vein of argumentation for the definition to be objective, the first candidate that comes to mind is some kind of formalism. Indeed, as it will be clear in this chapter, the closely related concept of computation (viz. algorithm) is generally investigated in such a framework.

There are further clues as to what the definition should include.

Abstraction is the primary means to capture the essentials of what is understood by the concept of mechanism. And abstraction should be employed at an appropriate level; broad enough as to cover as much of the target cases of the concept's extension as

possible, and narrow enough, as to not compromise its coherence. Again, the closely related concept of computation should -and usually does- make use of abstraction, too and also comply with the provisions given above.

Finally, observing the conceptual, structural and functional similarities between these two abstractions, a sufficiency thesis will be formulated: what is necessary for the specification of a mechanism (to be used for some scientific explanation), can be sufficiently captured by a specification of some corresponding computation.

2.2 Gandy Machine

Within the shared context of mechanisms and computation, the first historical attempt to foundationally define both of these concepts was made by Robin Gandy (1980).

However, Gandy's efforts, a first at the time when the theoretical and practical pillars of computational knowledge were not well-established and did not have much contact with other disciplines -less so with biological sciences or philosophy of science theories, should not be of much use to us having some foundational role in elaborating the concept of mechanisms as they were from the beginning devised to remain narrowly within the boundaries of mathematics. Eventually -and ironically, however, and in an unrelated way to Gandy's own intended purpose- they may still have struck the right chord, to a certain extent, as to what a mechanism is (i.e. in some terms that are compatible with the new mechanistic understanding).

Gandy, being Turing's only PhD student and acting as his immediate intellectual heir, has suggested the definition of a machine, with a clearly formulated goal in the footsteps of his mentor. His particular motivation was, as depicted in Fig.2, probably influenced by the spectacular rise of electronic computers during the post-war era, to

establish a more objective way to define what a computation was, as Turing's own approach seemed, *prima facie*, a subjective description because it involved a human computer (although the computer was following a set of mechanical rules of thumb). A further influence on him was reportedly the consideration of parallelism of computational processes as this was another fact *de jour*, but at the same time, also an issue that caused a lot of people to scratch their heads, back then. However, the modern approach to parallelism interprets this latter effort rather as a confounding factor which makes the core analysis (simple sequential computation) unnecessarily complicated and can be conveniently ignored, or postponed to a separate study.

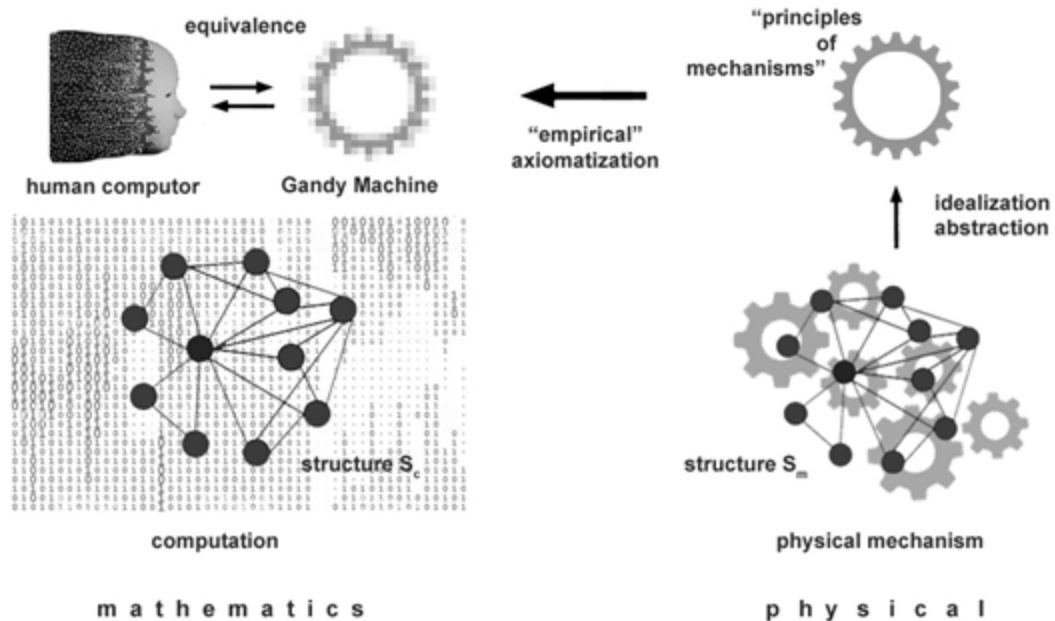

Fig. 2 Robin Gandy's project

Consequently, although Gandy's machine computes, unlike a human computer, "objectively", it is still Turing complete (i.e. has the same computational power of a Turing Machine). Commentators further state that the Turing Machine is constrained by

the bounds of a human computer, whereas that of Gandy is bound by physical considerations only.

So, what is the problem, then?

At least from the perspective of this thesis, Gandy's promising emphasis of the conceptual equivalence² of the three terms machine, mechanism and device is unfortunately deceptive. Indeed, the title of his paper seems to indicate this equivalence when it says: "principle for mechanisms"! The problem is, when using these terms, he does so without qualifiers (when he is indeed more specific, he prefers the term calculating to mean computation; again, an appropriate usage of older times) and thus the referents of his specification become equivocal. Contrastingly, in modern technical parlance -which is more cautious and never drops the qualification, the standard terminology is "computing machines" or, in a wider context, "computing mechanisms". Paraphrased to comply with the current standards, from the very beginning all the way down to end, I render Gandy's focus of attention to be about "computing machines".

His introductory arguments ("Roughly speaking I am using the term [machine] with its nineteenth century meaning", Gandy, 1980, p. 125) taken together with his later meticulous but unnecessary (Sieg, 2000, p.2) efforts to specify some empirical constraints ("much larger than the size of an atom", p. 130; "within ... the velocity of light", p. 136) contribute to this confusion. He need not delve into physical properties of a calculating system, simply because it is the emergent functionality and not the concrete properties

² *Note on terminology.* In the above statement we used "discrete deterministic mechanical device" to emphasize the somewhat restricted significance we are giving to the term "machine". Now that the point has been made we shall, for brevity, revert to the word "machine"; for the sake of variety, and for their flavor, we shall also sometimes use the words "device" and "mechanism" (for an object, not for a tenet) (Gandy, 1980, p126).

that enable such a system to calculate (on the other hand, it is known that he does so because he wants to counter Turing's approach that incorporates the finiteness of resources of a human computer). After all, such physical constraints are, in general, meant to be exactly those relevant descriptions which are mentioned when one talks indeed of some natural, non-calculating mechanisms, as used by contemporary scientists to explain their phenomena.

Before elaborating on this point, it may be appropriate to have a look at the original formulations by Gandy and try, thereafter, to specify -out of this picture- what is relevant for the definition of mechanisms in the light of this thesis.

He first makes a “characterization” of his framework (p. 125), and then proceeds to give his four “principles” (which can be taken as axioms) to build upon. The original passages are as follows:

(1) In the first place I exclude from consideration devices which are *essentially* analogue machines.

...

So I shall distinguish between “mechanical devices” and “physical devices” and consider only the former.³ The only physical presuppositions made about mechanical devices (cf. Principle IV below) are that there is a lower bound on the linear dimensions of every atomic part of the device and that there is an upper bound (the velocity of light) on the speed of propagation of changes.

(2) Secondly we suppose that the progress of calculation by a mechanical device may be described in discrete terms, so that the devices considered are, in a loose sense, digital computers.

(3) Lastly we suppose that the device is deterministic; that is, the subsequent behaviour of the device is uniquely determined once a complete description of its initial state is given.

Principle I (The form of description)

Any machine M can be described by giving a structural set $S_M \subseteq HF$ of state-descriptions together with a structural function $F: S_M \rightarrow S_M$. If $x_0 \in S_M$ describes an initial state, then $Fx_0, F(Fx_0), \dots$, describe the subsequent states of M .

Principle II (The principle of Limitation of Hierarchy)

The set-theoretic rank of the states is bounded. I.e.

$$\exists k. S \subseteq HF_k.^3$$

Principle III (The Principle of Unique Reassembly)

There is a bound q and for each $x \in S$ a set $Q \subseteq P_F(TC(x))$ ⁴ from which x can be uniquely reassembled such that $|s| < q$ for each $s \in Q$.

Principle IV (Preliminary version). The next state, Fx , of a machine can be reassembled from its restrictions to overlapping “regions” s and these restrictions are locally caused.

That is, for each region s of Fx there is a “causal neighborhood” $t \subseteq TC(x)$ of bounded size such that $Fx|_s$ depends only on $x|_t$.

The first characterization has, as mentioned previously, two radical empirical constraints: there is a lower bound (atomic dimensions) and an upper bound (the velocity of light). Two more constraints are also of fundamental value: first, that analog machines are excluded (except they can be discretized) and only discrete systems are considered; second, the system is deterministic, that is, a complete description of the system at any time is possible once its initial conditions are given.

³ Each of the principles involves certain finiteness or boundedness conditions. We say that a quantity is *bounded* if there is a number k which may depend on the machine considered, but which does not depend on the state for which the quantity is being evaluated, such that in all states the value of the quantity is less than k (Gandy, 1980, p. 130).

⁴ The transitive closure of $x, TC(x)$ is defined by

$$TC(x) =_{df} \cup \{ TC(y) : y \in x \} \cup (x \cap L) \text{ (p. 128).}$$

also,

Let P be a set of parts for x of bounded size; it is not to be expected that x will be uniquely determined by all the $x|_{\{z\}}$ ($z \in P$) (p. 133).

A further very important consideration is, however, usually neglected in the literature on Gandy's work: in the second characterization, there is a reference to the "progress" of the calculation; that is, calculations (computations) proceed irreversibly in one direction in the time domain which makes the whole process "sequential" (which is the most relevant qualifier of a computation which is Turing complete). Since the "parallelism" Gandy is trying to capture in his account is synchronous, the sequentiality of the considered system is maintained (it is usually considered a trivial task to show that synchronous parallel computations can be converted to sequential ones).

What about the principles? Is there something in them that can be "salvaged" on behalf of my project? Indeed, yes.

Principle I is a detailed description of what was stipulated in the last characterization: the systems considered are deterministic ones.

Principles II and III allow, to use a current terminology, compositionality of parts (states), albeit further imposing on them the condition of finite boundedness.

The Principle IV may be the most important empirical stipulation (Gandy himself thinks likewise, p. 135) in addition to the first characterization explained previously. It sets the conditions of causality, but it turns out that capturing it in mathematical terms is not straightforward. Gandy readily admits that his formulation "does not apply to machines obeying Newtonian mechanics", p. 145). Indeed, this is not merely a mathematical problem; in the light of our present knowledge of the workings of the physical reality, any account of causality seems to face the same difficulty of begging an explanation for the "action-at-a-distance" considerations.

To summarize the Gandy Machine in essential terms, it is a model for deterministic discrete sequential "computational" systems whose parts are subject to

local causality (p. 125). But as suggested in its mathematical formulation, it has only a theoretical utility (as intended by Gandy) and cannot be of any practical significance for the scientists to explain their phenomena. It may well serve the philosophers of science in giving a clear and rigorous definition of what a mechanism is, provided that the correspondence between physical mechanistic systems on one hand, and computational systems on the other, is adequately shown. Even in that case, its scope may be limited to a few cases, as molecular and systems biology instances. For example, where scientists observe and talk about regulatory mechanisms are in general stochastic and asynchronous⁵ it does not apply. These are two constraints that are not met by Gandy machines—while the stochastic versions of Turing Machines are readily conceivable, the asynchronicity condition still defies most computational approaches, including the Turing Machine abstraction.

2.3 A break: The historical context

It may be appropriate to stop here momentarily to put things into a historical perspective to gain some insight.

What is computation? Somehow, it seems to be connected to machines, including, when interpreted with charity, human computers. On the other hand, conventional wisdom based on our collective experiences suggests it has some mathematical character.

⁵ In computational contexts, a compositional system (an assembly) is said to be asynchronous if its interacting parts affect each other abruptly without waiting for the affected parties to conclude their “subcomputation”; in these circumstances, no algorithm can be specified beforehand that would represent and anticipate the future states of the system.

Indeed, apart from some practical applications that date back to ancient times (including Antikythera, orrery, astrolabe, Leibniz calculator, Babbage's Differential Engine, etc.) the fate of computation was bound to mathematics when Hilbert started his efforts to formalize mathematics during the turn of the last century. In order for his optimistic endeavor to succeed in some essential part of the project (the *Entscheidungsproblem*, for example), he claimed that a formal procedure was needed to do the job, which Kripke (2013, p. 81) calls simply Hilbert's thesis and states as the claim that "the steps of any mathematical argument can be given in a language based on first order logic (with identity)". In the course of events, however, Kripke reports, quoting Gandy (p. 85), a certain pessimism emerged within the Hilbert tradition starting with "von Neuman (1927), who worries that a decision procedure for the Entscheidungsproblem would in effect abolish mathematics in place of a mechanical procedure".

Indeed, as history reports it, the blow came, in the form of his incompleteness theorem, from Gödel during the famous Königsberg Conference, back in 1930. And the negative answer to the Entscheidungsproblem by Turing in 1936 was the second bad news for formalism. But a new "mechanical/computational" era was just catapulted into being and Gandy's "machine" ideal in search of objectivity helped fortify this process.

After three quarters or more of a century and a rich heritage of research built on top of these initial undertakings, can it be said that now a secondary wave of contemplations in mathematics and logics with some philosophical significance is set in action? Well, the mainstream literature does not resonate yet in that direction. The seminal paper by Dershowitz & Gurevich (2008) claiming to offer a rigorous mathematical alternative to

the hitherto only informally stateable Church-Turing Thesis (CTT), and Kripke's own thesis (2013) in line with the former, have yet to be absorbed and duly assessed.

Within the framework of this thesis, the importance of these two works rests in their quest to capture, in a new perspective, the essence of what computation (viz, algorithm) is. More specifically, their novel unfolding of the CTT which is not based on the usual "λ-calculus" or "moving tape and read/write head" formalisms but rather on a framework of states and state transitions shows their utility in attacking the problems that surround the mechanistic approach. Indeed, this is the proper subject of the third chapter where Gurevich's Abstract State Machine (ASM), an equivalent formalism to Turing Machine (TM) is examined for this purpose. However, before proceeding to this task, let us briefly dwell on Kripke's efforts that perfectly align with the goals of this thesis, although he seemingly has quite a different agenda (Kripke is preoccupied with the "mathematical proof" of CTT as reported above).

2.4 Kripke's project

Kripke's aim is to give a rigorous mathematical proof for the CTT⁶ which has been generally believed to be technically and practically not provable since it is stated in an informal setting. His strategy given as a rough sketch -in his own words, is as follows:

Assuming the steps of the deduction can be stated in a first order language, the Church-Turing thesis follows as a special case of Gödel's completeness theorem (first-order algorithm theorem). I propose this idea as an alternative foundation for the Church-Turing thesis, both for human and machine computation. (Kripke, 2013, p. 77)

⁶ Closer to Turing's own wording, the thesis reads "a function is 'effectively calculable' if its values can be found by some purely mechanical process" (Turing, 1939).

And the details of this strategy are based on the following steps: “a computation is just another mathematical deduction, albeit one of a very specialized form” (p. 80). And applying this strategy to algorithms (i.e., to effective calculability) he ends up with the claim that “we can state a theorem restricted to algorithms whose steps can be stated in first-order logic” (p. 93).

Additionally, he stipulates that the transition from one state to another proceeds, in accordance with the spirit of the CTT, in discrete steps

As I said, computation is simply a form of mathematical argument. Let us consider only those devices that are describable in a first-order language, and whose program is such that the successive states logically follow from each other, one by one, together with the program and perhaps some basic mathematical assumptions. Any particular computation by the machine is assumed to be finite in length, and the machine states describable finitely, and following each other discretely (p. 91).

Kripke criticizes Gandy for not taking the alternative route of defining his class of machines stipulatively (p. 90); he muses that there would not be an issue of an empirical basis (p. 90) if he did so. Therefore, he frames his own approach, as an alternative to Gandy’s, by divorcing the question of machine computability from constraints issuing from empirical assumptions.

Finally, it is worth mentioning that when exposing his own approach, Kripke touches the issue of parallelism to give Gandy’s article a comprehensive inspection as this is part of Gandy’s thesis, but for the contemporary philosophy of computation it has marginal relevance (referred to mainly in discussions of the not-so-central hypercomputation approaches). Elaborating on stochastic cases would be more interesting (he could have considered, for example, probabilistic soft logic, or

probabilistic FOL), although our state-of-the-art knowledge of computations already includes probabilistic Turing Machines, too.

In the conclusion of his exposition, he gives due credit to two papers by Sieg (2008) and Dershowitz and Gurevich (2008) and admits that the basic idea he tries to expound is explicitly given by them. (The latter reference is especially decisive with respect to the material used in the next chapter.)

Let me now briefly illustrate what part of Kripke's argument is in accord with the main argument of this thesis. To remind his simple argumentation once more, Kripke claims that a computation is just another mathematical deduction; but it is known that another concept for mathematical deduction is mathematical proof, a term which Kripke uses in his article several times but never equates explicitly with mathematical deduction itself; this may be, well, because he may have chosen to keep the two usages clear and distinct (that is, his attempt to give a mathematical proof of CTT, and the content of his argument that a computation is a mathematical proof/deduction).

The benefit of preferring the concept of proof over deduction is, however, its immediate association with the Curry-Howard-Lambek (CHL) isomorphism, which states that computer programs (i.e. computations) are mathematical proofs. The deductive approach is apparently another manifestation of this well-established isomorphism which is usually shown indirectly by making use of type theories that have been traditionally pursued by another community (type theories have changed a lot during the last two decades and currently more mathematicians are involved). Kripke's argument is quite direct as compared to CHL isomorphism.

Using either mathematical deduction or mathematical proof, eventually the gist of the intended mathematical apparatus is the pure fact that one develops theorems from

theorems in a step-wise move -in the presence of some finite instruction sets (axioms) with a set of some “production” rules. That this process is a “development” is more salient and pronounced when computations are given, in an equivalent formalism, as representations of states and state transitions that are constituents of and governed by algebraic structures. This point is explicitly endorsed by Kripke (p. 94) when he states that the algebraic structure-based approach chosen by Dershowitz and Gurevich (2008) is superior to that of Gandy (who used hereditary finite sets as constituents of his machines): “they appeal to the same mathematical experience that I do”.

Proofs, or, theorems developed from theorems, can be considered as productions; this is indeed witnessed by the name given to the set of syntactic rules that drive the said development; they are simply called “production rules”.

CHAPTER 3

MACHINATION, COMPUTATION

The objective of this thesis is to better equip the new mechanism approach in its quest to provide an alternative scientific explanation methodology to Hempel's Deductive-Nomological model for special sciences, by appropriately defining what a mechanism is. And the starting point to accomplish this was to make use of the formalism of computational disciplines. The objective then becomes to show the correspondence between the abstracted models of these two realms.

3.1 The correspondence between the two realms

I hope that observing the conceptual, structural and functional similarities between these two abstractions, a sufficiency thesis will be formulated: what is necessary for the specification of a mechanism (to be used for some scientific explanation), can be sufficiently captured by a specification of some corresponding computation.

To accomplish this, the two notions of computation and machination (what a mechanism does) must be conceptually brought together as close as possible.

3.1.1 Abstractional adjustment of the notion of computation: ASM

Computations can be given in a variety of mathematical formalisms mostly produced in the first half of the twentieth century. The canonical model is the Turing Machine as theorized by Alan Turing in 1936. When introducing an alternative formalism, it is usually the creator's responsibility that the new candidate is Turing complete, that is, can compute all functions that are Turing Machine computable. This thesis relies on Abstract

State Machine (ASM) formalism as suggested by Yuri Gurevich back in (1985), and formally introduced in (2000). A subsequent paper by Gurevich written with Dershowitz (2008) also targeted the CTT (which has been usually considered not provable as it is given in an informal formulation not amenable to mathematical proof) and provided a mathematical proof (see Kripke’s similar work and endorsement in the previous chapter).

The first issue that needs to be addressed when axiomatizing effective computation is: What kind of object is a “computation”? Once we agree that it is some sort of state transition system (Postulate I), we need to formalize the appropriate notions of “state” and of “transition”. To model states, we take the most generic of mathematical objects, namely, logical structures (Postulate II). To ensure that each transition step is effective, we require only that it not entail an unbounded amount of exploration of the current state (Postulate III). (Dershowitz & Gurevich, 2008, p. 306).

3.1.2 Abstractional adjustment of the notion of machination (mechanism): the *mechos*
In a similar vein, the definition of machination must be conceptually adjusted so that the correspondence between them can be established in a clear way.

Although quite probably expressed with relatively different conceptualizations -if not based rather on some radically different constituents, it is generally agreed on that a mechanism (machination system) consists of some parts, and additionally, some interactions between them. Capturing these basic ideas, I define a universal model of machination where a unit constituent, called *mechos* (μῆχος, μῆχοί), is stipulated whose interaction with other *mechoi* composes the machinational system. This unit element is not necessarily atomic, and can be further construed as another machinational system which is seen, from the point of view of the original system, just as a unit (a module, a black box) which is relevant with its specific input and outputs, and therefore, its

functionality. The black boxes can be, if desired and feasible, further investigated endoscopically to yield explanations at any specified level, subject to a series of why-how questions where why-questions provide explanations and how-questions give descriptions.

The concept of mechos captures efficiently machination (state-change) and causality, and also provides answers to both why- and how-questions of an explanation; in particular, “opening up” a black box constituent (represented by a mechos whose inner workings are hidden) of a larger ensemble through its substitution by yet another ensemble (i.e., some set of sublevel mechoi) to reveal its inner workings is conventionally an issue when investigators do so to get satisfactory answers to their how-questions regarding the functioning of that black box.

To put it in more general terms, mechoi can be articulated to each other by applying the one and same principle (hooking up the output of one mechos to the input of another one⁷⁷) and is closed under this operation; that is, an arbitrarily long articulation ensemble itself is, and can be abstracted and/or handled as, just another mechos at another level. The articulation process, which consists of simply connecting one mechos to another, is appropriately called enchainment.

It must be emphasized that the concept mechos is not an epistemological intermediary but rather of metaphysical significance for physical cases, that is, mechoi are not simply sketchy abstractions of the real parts of mechanisms but stand in full

⁷⁷ “One way of doing this is to define a function $\lambda : \Theta' \rightarrow \Sigma$ and so convert each output $\beta' \in (\Theta')^*$ into an input word $\lambda(\beta') \in \Sigma^*$ before applying it to the machine M .”

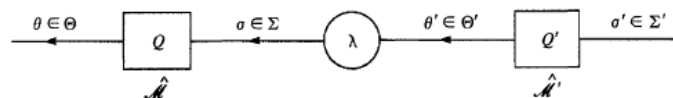

(Holcombe, 1982, p. 50)

correspondence to them capturing all their relevant functionalities. Also, note that the abstract version (the case of, for example, the abstract wage-price mechanism as used in economics) is also based on physical states (the totality of compensated wages, say, in a country, are physically represented and paid by a certain amount of physical currency; and similarly, the totality of prices in that country, are also represented and asked for by a certain amount of physical currency), although, probably, statistical evaluation and not causal connections between individual wages and individual prices will become the principal determinant in those cases.

The mechos consists of a state-bearer and a set of change-makers (these concepts are, as will be explicated in the next subsection, parallel to the computational counterpart ASM where there are a set of states -algebraic structures- and a set of functions that operate on the states). Furthermore, in a mechos, specifically, the change-makers (functions) are categorized, as depicted Fig.3, as the input and reflexive functions.

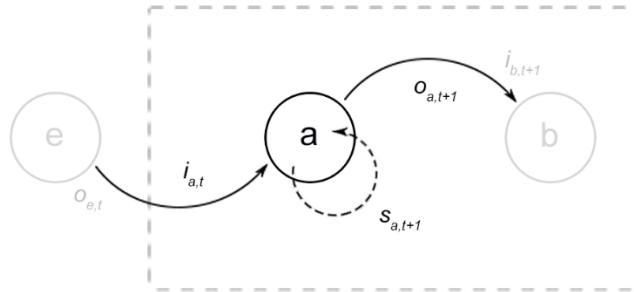

Fig. 3 The unit of machination: mechos

$$\begin{aligned}
 i_{a,t} &= f(o_{e,t}, s_{a,t}), & i \in I & & i : O \times S \rightarrow I \\
 s_{a,t+1} &= g(i_{a,t}, s_{a,t}), & s \in S & & s : I \times S \rightarrow S \\
 o_{a,t+1} &= h(i_{a,t}, s_{a,t}, i_{b,t+1}), & o \in O & & o : I \times S \times I \rightarrow O
 \end{aligned}$$

where I , S and O are the sets of input, internal and output states.

The functions reveal how the participating state-bearers will be affected by the interaction once initiated by one of them (in more complex situations like in the case of a many mechoi hooked up to a single mechos, the initialization can be triggered by more than one state-bearer). Referring to the state-bearer a , the main component of the representation given here, the following two change-makers are identified

1. the input change-maker $i_{a,t}$ as a function of both another (external) mechos e , and the capacities of the state-bearer a itself, both at time t ,
2. the reflexive, consequent state change $s_{a,t+1}$ affected at a later time $t+1$ on the state-bearer a by this interaction as a function of both the input function $i_{a,t}$ and the previous internal state of the state-bearer a at time t .

(The output change-maker of the state-bearer a is at the same time the input change-maker $i_{b,t+1}$ of another state-bearer b when they are connected in case of an enchainment.)

Two interesting philosophical issues arise. Here, one observation is that the reflexive change maker s which represents the capacities of the state-bearer a participates differently both in “receiving” the input interaction in a certain active way, and then in reflecting the “effects” of this initial interaction to the state-bearer in another way. The other issue is that it is clear from this picture that we cannot speak of capacities of a state-bearer from an absolute neutral point as they are actualized differently supervening on the input change maker. (Another interesting question is whether the reflexive change maker s can be triggered spontaneously by a state-bearer without a helping hand from an external agent).

The rectangle in dashed lines comprises a further transitively interacting pair of two mechoi as a causal unit in itself, where the mechos *a* is taken, now, as the triggering agent for another mechos *b*.

Why are states the best representation of a mechanical system? State-bearers do not need to be entities; they may be constituted for example, among others, by relational qualities that can be observed and assigned a “state”, too. Suggested alternatives such as entities (MDC, 2000), or situations, occurents, continuent (Krickel, 2018) unnecessarily complicate the description of what is essentially going on and give the impression that *they* are necessarily needed for machination to take place (these would be all cases of narrow abstraction). States and their changes (transitions) sufficiently represent such a system. Indeed, if we want to be broad enough in the extent of our explanatory mechanism to cover as many phenomena as possible, we should devise our theories in less specific terms (for example, in “state” terms rather than entities, properties, events, processes, phenomena, etc.). Ionization state of a molecule, concentration (state) of a certain quantity of a solution, the disassembled state of a bicycle, but also the given mood state of a person, the collective state of happiness in a society or the inflation rate (state) in a given economy are, for example, all eligible examples. Even dispositions or capacities are summarily represented by states (and their transitions).

The metaphysics of change-makers is not relevant for my purposes. What counts is the outcome (effect); the “change” itself.

3.1.3 The correspondence: it is established at two levels

That the abstracted model of a concrete mechanism, i.e. an assembly system (physical or “abstract”) in terms of its mechoi which themselves are specified by states and state transitions, is defined and described in terms of exactly the same concepts as a computation (defined and described in the preferred formalism of Dershowitz & Gurevich, and Kripke, that is, given solely by parameters of states and state transitions) cannot be merely a happy coincidence. When modeling a mechanism in terms of its mechoi giving states and state transitions at a unitary level, there is no discernible way to differentiate the given abstraction as to judge whether it is a machinational (as stipulated here) or a computational unit. There is correspondence at this level (shown by the oppositely directed smaller two arrows at the top of Fig. 4).

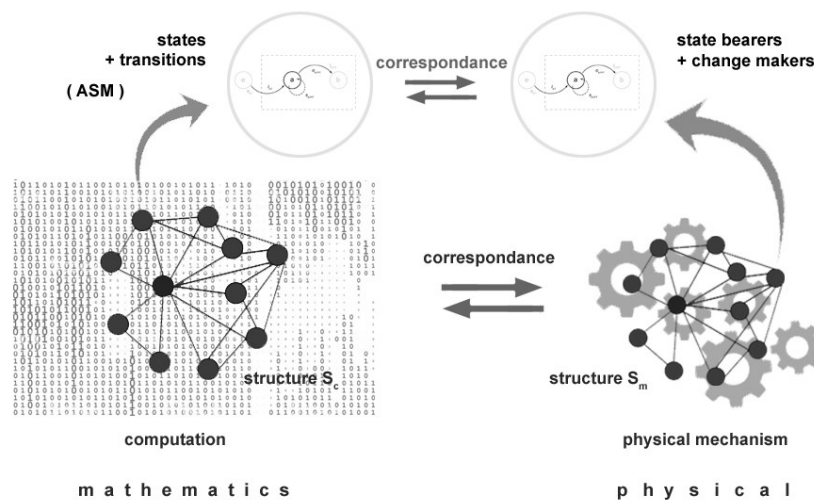

Fig. 4 Two level correspondence between computation and machination

On the other hand, there is a second, more essential correspondence between some given machinational and computational systems, at the system level (as depicted by the

oppositely directed bigger two arrows in the middle of Fig. 4), provided that they have the same structural properties which assemble their constituent units in one and same way. In both assembling cases, the output of a unit becomes the input of the next unit.

To summarize, when defining an abstract model of a system in either machinational or computational terms, interpretations in one or other perspective at both the unitary and structural levels exactly correspond to each other.

3.1.4 To name or not to name!

The essential concept of “production” of computation (as explicated in the Kripke section above) is comparable to the essential concept of “causality” of machination (mechanisms). This relationship of semantic kinship can be further investigated and an active stance can be taken to redefine “causality” in such a way that the two cases are extensionally brought together closer and closer. This strategy is encouraged both by the pluralist claims by Nancy Cartwright (her alternative conception of thick causal concepts⁸, 2007) and some established views in the linguistics community proclaiming that treating all causatives the same way as if they included the same causal element would be a gross oversimplification (see Nolan, 2016).

Therefore, stating the core content of the causal element in simpler more primitive notions as “bringing about a change” (which was previously specified as the common denominator of a pluralist family of the concept causality) is a legitimate illuminating move and “bringing about a change” is definitely part of another notion

⁸ Nature is rife with very specific causal laws involving these causal relations, laws that we represent most immediately using content-rich causal verbs: the pistons *compress* the air in the carburettor chamber, the sun *attracts* the planets, the loss of skill among long-term unemployed workers *discourages* firms from opening new jobs . . . (Cartwright, 2007, p19)

which we conceptualize as production. The next conceptual step would be the unfolding of mathematical deduction as a case of production. We can now name it, and say out loud that deduction (and per Kripke, computation, too) is, in some (broadened) sense, causal as it produces a new theorem within the framework of axioms and production rules.

3.2 Examples

Concrete examples may reflect conceptual complexities in a clear way and they also serve as a testbed if a concept is indeed instantiated (that is, if there is at least one thing that falls under that concept). I will here present two exemplary cases, one of simpler common nature and the other, of a more specialized, “scientific” complexity.

A car is a simple mechanism. Its functioning is usually known if not down to minute details by most people and a quick consensus can be established that it is indeed a mechanism par excellence. The abstraction (model) of a car can be given at several functional levels. The example depicted in Fig.5 shows a certain part (energy supply subsystem) of its total functionality.

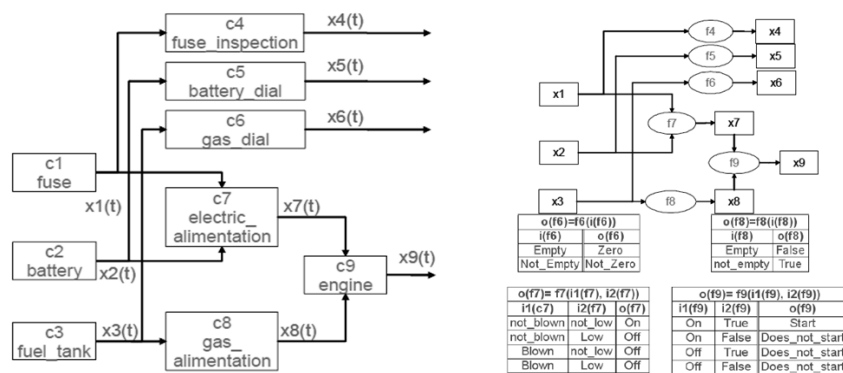
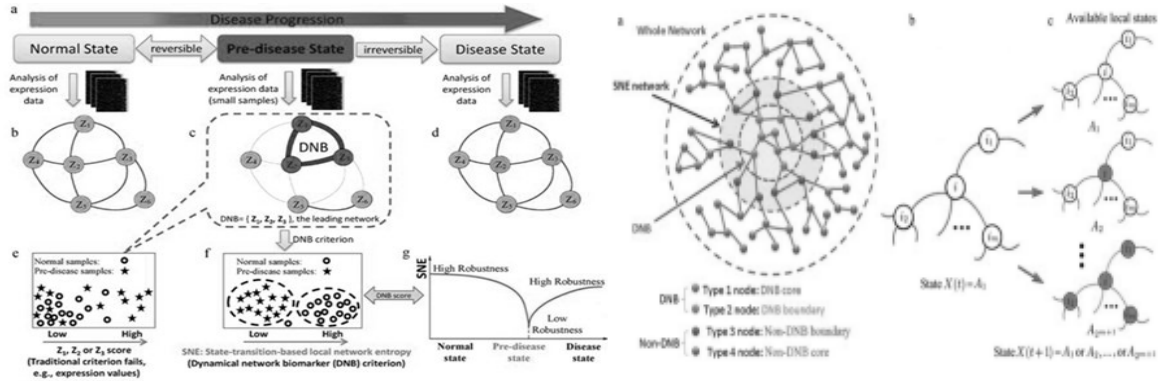

Fig. 5 The functional model of a car subsystem

(Ahdab & Le Goc, 2010)

Furthermore, it is simply given in binary coded state values and transition functions.

In Fig.6 a more complex example is given for a biomolecular mechanism.



In this example, the critical transition (as represented by a biomolecular network) from a normal state to a disease state is used as the indicator of an essential mechanism for a certain disease development. The biomolecular network is specifically defined as a state-transition-based local entropy network (SNE).

The state-transition-based local entropy network (SNE) of the left panel is given here in detail: a local network centered on node i is given as a stochastic Markov process of the state transitions between two time points t and $t + 1$; although this approach is also based on state transitions (as propounded throughout this thesis) the similarities end here because Markov processes are used as compared to the more generic abstract state machines (ASM) that are suggested in this thesis; stochasticity poses no problem either as it can be easily adapted by ASMs.

Fig. 6 The computational (network) model of some disease progression (Liu et al., 2010)

Note that William Bechtel, one of the leading mechanistic approach proponents, recently suggested to use network analysis for biology, too. Network analysis with weighted vertices or edges is just another computational system to model mechanisms with states and state transitions (Bechtel, 2017, p.460)

3.3 The practical minimality criterion: Constrain it to molecular and systems biology

Heeding to some mild criticisms raised against the mechanistic approach as to what the philosophers say does not overlap with the practice of molecular and systems biologists as explored in Chapter 1, it may be appropriate for suggested definitions and explications of mechanism to be tested for their applicability to these particular special sciences. Embracing this stance, one must then strive to satisfy the following criteria which are applicable to most of the phenomena the scientists encounter in their explanatory practices:

- that the interactions are local within the defined boundaries of the system
- that the participant units comprising the considered system (mechanism) may be massive in their number
- that the overall process is not simply deterministic but rather stochastic in its nature (typically handled by the physically well-characterized Gillespie algorithm, as suggested by Luca Cardelli, 2005, p.165)
- that the interactions are significantly asynchronous in their effect (when considered at the lowest level of interest).

Furthermore, it is a trivialeity of any (suggested) mechanistic approach valid also for these biological sciences that some parts of the system can be conceptualized as a black box abstraction for which the explanation of its inner workings may be postponed by considering the relevant input and output transitions only.

Beyond these minimality conditions, of which the stochasticity condition makes formulations and definitions considerably more complex -but still manageable- as compared to the milder deterministic version, any effort to expand the breadth of

mechanistic explanation as to cover also the nonlocality cases probably requires a radical break from this rather modest reference approach. All this said, it must be admitted, however, the mechanistic approach advocated throughout this thesis is deterministic. However, although the introduction of the stochastic variety is usually a tedious one, it is but conceptually simple task that can be postponed for all practical purposes.

3.4 Cardelli and the state-of-the-art of systems biology

In the summary diagram given in Chapter 1 and depicting several mechanistic accounts, Luca Cardelli was designated outside the philosophical circles, but definitely at the center of systems biology practice, as a computer scientist. He gives (p. 148) a generic scheme for abstract machines, exactly in concordance with the machine concept defended in this thesis, for some different but complementary operational machine abstractions (Gene Machines, Protein Machines and Membrane Machines, p.149) typically used in systems biology:

An abstract machine is characterized by:

- A collection of discrete states.
- A collection of operations (or events) that cause discrete transitions between states.

The evolution of states through transitions can in general happen concurrently. The adequacy of this generic model for describing complex systems is argued,

He also suggests a unifying computational process formalism, π -calculus, to cover the operations of all the three abstract machines homogeneously. His prototypical mechanism definition satisfies all the given criteria specified in the previous section: the massive quantity of the participant units, the trivial locality of the interactions within the

defined boundaries of the system, and stochasticity and asynchronicity of the underlying processes.

3.5 Benefits: Allowing modularity and representation of capacities

It is noteworthy to emphasize, once more, that the proposed approach for defining mechanisms in this thesis allows modularity (that is, a unitary black box element can be substituted by an effectively equivalent module which is a complex ensemble of some other units at a lower detail level). This also enables a scientist to give explanations at any desired level of resolution, and then, depending on the incoming why- or how-question requests, bottoming out whenever necessary.

A second benefit is the representation and operational control of “*capacities*” in terms of reflexive transition functions defined on the mechoi. However, the delivery of interrelated but separate accounts of different end effects of capacities both at the mechos and system levels may be extremely complicated, if ever feasible.

3.6 Epilogue: Is this science or philosophy?

After so much exposition, investigation, criticism and suggestion offered for the mechanistic approaches in the “philosophy” literature the way it is done, one is inescapably challenged by the question posed by Franklin-Hall (2016, p.70) as I first mentioned toward the end of the first chapter. What is the proper critical distance of the philosopher of science regarding the definition of what a mechanism is? The question gravitates more when the practicing scientist contests the philosopher’s understanding, again, the way it is done. After all, philosophy of physics, for example, does not dare to

talk, say, about how renormalization groups should be defined to have a genuine representation of physical reality.

On the other hand, no practicing biologist leaves her lab to sacrifice a good amount of her time to first establish a sound and justified methodological apparatus to build up her work on with confidence. It is true, a handful of scientists in any discipline become attracted to questions that scrutinize the philosophical underpinnings of their fields and thus serve as translators between philosophers and pure practitioners. But such activities are usually grey areas.

Indeed, in the case of systems biologists, they have been definitely in need to receive some help from outside, such as from Luca Cardelli, as explained previously. Interestingly, not philosophy but a third outsider field has been summoned to cooperation first (computer scientists and biologists can get along well with each other although this is understandable as the cooperation between sciences and mathematics has a track record that goes back many centuries).

Assuming a strategy is adopted to pursue a formal definition for mechanisms, as defended in this thesis, yet another observation seems to be in place indicating that this debate unavoidably incorporates also a certain degree of philosophy of mathematics: the metaphysics of computation, its deductive nature, its claimed -and widely accepted- atemporality in the face of every temporal concrete realization, indeed, its very definition (and the extension as to what it covers in physical reality, if ever) are all big questions. And they sit next to the other big questions, as the debate of the last two decades shows, pertaining to what mechanisms indeed are.

REFERENCES

- Ahdab, A., & Le Goc, M. (2010). Learning dynamic Bayesian networks with the TOM4L process. *Proceedings of the Fifth International Conference on Software and Data Technologies, 2*.
- Bechtel, W. (2017). Analyzing network models to make discoveries about biological mechanisms. *The British Journal for the Philosophy of Science, 70*(2), 459–484.
- Bechtel W., & Abrahamsen, A. (2005). Explanation: A mechanist alternative. *Studies in History and Philosophy of Biological and Biomedical Sciences, 36*(2), 421-41.
- Bechtel, W., & Richardson, R. C. (1993). *Discovering complexity: Decomposition and localization as strategies in scientific research*. Cambridge, MA: The MIT Press.
- Boniolo, G., & Campaner, R. (2018). Molecular pathways and the contextual explanation of molecular functions. *Biology & Philosophy, 33*(3-4):24.
- Cardelli, L. (2005). Abstract machines of systems biology, In C. Priami, et al., (Eds.), *Transactions on Computational Systems Biology, 3*, 145-168.
- Cartwright, N. (2007). *Hunting causes and using them: Approaches in philosophy and economics*. Cambridge, UK: Cambridge University Press.
- Dershowitz, N., & Gurevich, Y. (2008). A natural axiomatization of computability and proof of Church's thesis. *Bulletin of Symbolic Logic, 14*(3), 299-350.
- Franklin-Hall, L. (2016). New mechanistic explanation and the need for explanatory constraints. In K. Aizawa, & C. Gillett (Eds.) *Scientific composition and metaphysical ground* (pp. 41–74). Basingstoke, UK: Palgrave MacMillan.
- Gandy, R. (1980). Church's thesis and principles for mechanisms. *The Kleene Symposium. North-Holland, 123-148*.
- Glennan, S. S. (1996). Mechanisms and the nature of causation. *Erkenntnis, 44*(1), 49-71.
- Glennan, S. S. (2002). Rethinking mechanistic explanation. *Philosophy of Science, 69*(S3), S342-S353.
- Glennan, S. S. (2010). Mechanisms. In H. Beebe, C. Hitchcock, & P. Menzies, (Eds.), (2010), *The Oxford handbook of causation*. Oxford, UK: Oxford Handbooks Online.
- Glennan, S. S., & Illari, P. M. (2018). (Eds.), *The Routledge handbook of mechanisms and mechanical philosophy*. New York: Routledge.

- Gurevich, Y. (1985). A new thesis. *Abstracts, American Mathematical Society*, p. 317, abstract 85T-68-203.
- Gurevich, Y. (2000). Sequential abstract-state machines capture sequential algorithms. *ACM Transactions on Computational Logic*, 1(1), 77-111.
- Hedström, P., & Swedberg, R. (1996). Social mechanisms. *Acta Sociologica*, 39(3), 281-308.
- Holcombe, W. M. L. (1982). *Algebraic automata theory*. Cambridge, UK: Cambridge University Press.
- Illari, P., & Williamson, J. (2011). What is a mechanism? Thinking about mechanisms across the sciences. *European Journal for Philosophy of Science*, 2(1), 119-135.
- Krickel, B. (2018). *The mechanical world: The metaphysical commitments of the new mechanistic approach*. Basel, Switzerland: Springer Nature Switzerland AG.
- Kripke, S. A. (2013). The Church-Turing “thesis” as a special corollary of Gödel’s completeness theorem. In B. J. Copeland, C. Posy, & O. Shagrir, (Eds.), *Computability: Turing, Gödel, Church, and beyond* (pp. 77-104). Cambridge, MA: The MIT Press.
- Levy, A. (2013). Three kinds of new mechanism. *Biology & Philosophy*, 28(1), 99-114.
- Liu, R., Li, M., Liu, Z., Wu, Ji., Chen L., & Aihara K. (2012). Identifying critical transitions and their leading biomolecular networks in complex diseases. *Scientific Reports*, 2, 813.
- Machamer, P., Darden, L., & Craver, C. (2000). Thinking about mechanisms. *Philosophy of Science*, 67(1), 1–25.
- Moss, L. (2012). Is the philosophy of mechanism philosophy enough? *Studies in History and Philosophy of Biological and Biomedical Sciences*, 43(1), 164–172.
- Nolan, B. (2016). Causal relata and event chains in the concepts transfer, let/allow and permission in modern Irish. In C. Perinián-Pascual & E. M. Mestre-Mestre (Eds.), *Understanding meaning and knowledge representation: From theoretical and cognitive linguistics to natural language processing* (pp. 1-23). Cambridge, UK: Cambridge Scholars Publishing.
- Pearl, J. (2000). *Causality: Models, reasoning and inference*. Cambridge, UK: Cambridge University Press.
- Piccinini, G. (2007). Computing mechanisms. *Philosophy of Science*, 74(4), 501–526.

- Sieg, W. (2000). Calculations by man & machine: Mathematical presentation. In W. Sieg, R. Sommer, C. Talcott, (Eds.), *Philosophy of modern mathematical and logical thought - Part IV* (pp. 390-409). Cambridge, UK: Cambridge University Press.
- Sieg, W. (2008). Church without dogma: Axioms for computability. In B. Cooper, B. Löwe, & A. Sorbi, (Eds.), *New computational paradigms: Changing conceptions of what is computable* (pp. 139–152). New York: Springer.
- Turing, A. M. (1939). Systems of logic based on ordinals. *Proceedings of the London Mathematical Society*, s2-45(1), 161–228.
- Woodward, J. (2002). What is a mechanism? A counterfactual account. *Philosophy of Science*, 69(3), S366–S377.
- Woodward, J. (2003). *Making things happen: A theory of causal explanation*. Oxford, UK: Oxford University Press.