

FOR REFERENCE

NOT TO BE TAKEN FROM THIS ROOM

THE SOLAR-ASSISTED
HEAT PUMP SYSTEMS FOR
SPACE AND WATER HEATING

by

İffet Naz AŞÇIOĞLU

B.Sc. in M.E., İ.T.Ü., 1983

Submitted to the Institute for Graduate Studies in
Science and Engineering in partial fulfillment of
the requirements for the degree of
Master of Science
in
Mechanical Engineering

Bogazici University Library



39001100313447

14

Boğaziçi University

1986

ACKNOWLEDGEMENT

I am greatly indebted to my thesis advisor Dr. Emre AKSAN for his assistance and his helps and constant support during its development.

I would further like to express my thanks to Doç.Dr. Fahir BORAK and Y.Doç.Dr. Vahan KALENDEROĞLU for serving on my thesis committee.

İffet Naz Aşçioğlu

197675

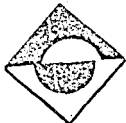

SUMMARY

In this study, solar-assisted heat pump systems, their contribution to reduce the consumption of non-renewable energy and their compensation for some of the shortcomings of the individual systems are considered. The base solar systems and base heat pump systems are also covered, before going into the hybrid systems.

Three special types of solar-assisted heat pump systems such as parallel, series and dual systems are included, and closely examined in various aspects. Their advantages over the base solar energy systems and the base heat pump systems and also over one another are stated. The efficiency of each system and the ways to improve the efficiency is discussed.

Ö Z E T

Bu çalışmada güneş enerjisi ile desteklenen ısı pompası sistemleri, yinelenemeyen enerji tüketimini azaltmaya katkıları ve her iki sistemin ayrı birer sistem olarak çalışmaları esnasında ortaya çıkan eksiklikleri nasıl telafi ettikleri incelenmiştir. Güneş enerjisi ile desteklenen ısı pompası sistemlerinin incelenmesinden önce; güneş enerjisi ve ısı pompası sistemleri ayrı sistemler olarak ele alınmıştır.

Paralel, seri ve çift sistemler olarak adlandırılan üç özel güneş-destekli ısı pompası sistemleri incelenmiş, ve her özel sistemin güneş enerjisi sistemleri ve ısı pompası sistemlerine; ve herbirinin diğerine göre üstünlükleri belirlenmiştir. Sistemlerin yeterlilikleri ve bu yeterliliğin arttırılmasındaki önemli unsurlar tartışılmıştır.

TABLE OF CONTENTS

	<u>Page</u>
ACKNOWLEDGEMENT	iii
SUMMARY	iv
ÖZET	v
LIST OF FIGURES	viii
LIST OF TABLES	x
INTRODUCTION	1
PART 1 - THE HEAT PUMP	
1.1. World Energy Situation	4
1.2. The Growth of Heat Pump Application	8
1.3. Heat Pump and Its Operation Principle	11
1.4. Heating and Cooling Modes	12
1.5. Ideal Vapor Compression Cycle	15
1.6. Heat Pump Performance	17
PART 2 -	
2.1. Classification of Major Heat Pump Designs	24
2.2. Application Areas of Heat Pump Systems	29

	<u>Page</u>
2.3. Types of Heat Pumps	33
2.3.1. Operation of Vapor Compression Heat Pump	33
2.3.2. Operation of Absorption Heat Pump	40
2.3.3. Vapor Set Heat Pumps	45
2.3.4. Gas Cycle Heat Pumps	45
2.3.5. Thermo-Electric Heat Pumps	
 PART 3 - SOLAR ENERGY AS THE HEAT SOURCE	
3.1. Conventional Solar Water Heater	49
3.2. Conventional Solar Space Heating	55
3.3. Solar Energy Heat Pump Systems	62
3.4. Performance of Combined Solar Heat Pump Systems	70
3.4.1. Discussion	80
3.4.1.1. Effects of Increased Storage Size	85
3.4.1.2. Effect of Improved Heat Pump Performance	86
3.4.1.3. Effects of Climate	87
3.5. Conclusions and Recommendations	89
 REFERENCES	 91

LIST OF FIGURES

		<u>Page</u>
FIGURE 1.1.	Primary Energy Consumption	6
FIGURE 1.2.	Heating by a Heat Pump	14
FIGURE 1.3.	Cooling by a Heat Pump	14
FIGURE 1.4.	Ideal Vapor Compression Cycle	16
FIGURE 1.5.	Thermodynamic Principle of Heat Pump	18
FIGURE 1.6.	T-S Diagram of Carnot Cycle	20
FIGURE 1.7.	P-h Diagram of Rankine Cycle	22
FIGURE 1.8.	COP at Various Refrigerant Temperatures	23
FIGURE 2.1.a	Air/Air Heat Pump	26
b	Water/Air Heat Pump	27
c	Water/Water Heat Pump	28
d	Water/Water Heat Pump with Ground Water as Heat Source and Underfloor Heating	28
FIGURE 2.2.	Diagram of a Compression Heat Pump	33
FIGURE 2.3.	COP for Vapor Compression Heat Pumps	39
FIGURE 2.4.	Schematic Diagram of an Absorption Heat Pump	42
FIGURE 2.5.	Vapor Jet Compressor	47
FIGURE 2.6.	Thermoelectric Heat Pump	47
FIGURE 3.1.	Simple Solar Collection System	49
FIGURE 3.2.	Basic Flat Plate Solar Collector	51

FIGURE 3.3.	Typical Efficiency Curve for Single Glazed Collector	51
FIGURE 3.4.	System with Antifreeze Loop and Internal Heat Exchanger	54
FIGURE 3.5.	System with Antifreeze Loop and External Heat Exchanger	54
FIGURE 3.6.	Schematic of Basic Hot Air System	58
FIGURE 3.7.	Detailed Schematic of a Solar Heating System Using Air	58
FIGURE 3.8.	Schematic of a Reversible Heat Pump System	64
FIGURE 3.9.	Operating Characteristics of a Residential Heat Pump	65
FIGURE 3.10.	Series Solar Heat Pump System	67
FIGURE 3.11.	Parallel Solar Heat Pump System	67
FIGURE 3.12.	Dual Source Heat Pump System	68
FIGURE 3.13.	3 Ton Air-to-Air Heat Pump	74
FIGURE 3.14.	Fraction of Annual Load Met by Free Energy as a Function of Collector Area in Madison	79
FIGURE 3.15.	Heating Contributions from all Possible Sources for Combined Conventional Systems	82

LIST OF TABLES

		<u>Page</u>
TABLE 1.1.	Oil Production by Present Members of OPEC	5
TABLE 1.2.	Total World Fossil Fuel Reserves and Consumption	7
TABLE 1.3.	Fossil Fuel Supply in 2000	7
TABLE 2.1.	Parameters of Various Refrigerants	35
TABLE 3.1.	Typical Design Parameters for Solar Air Heating System	61
TABLE 3.2.	Typical Design Parameter Ranges for Liquid Solar Heating System	61
TABLE 3.3.	Collector Parameters	75

INTRODUCTION

Solar energy systems and heat pumps are two promising means of reducing the consumption of non-renewable energy resources and the cost of delivered energy for space heating/cooling and water heating. The combination of them have a number of attractive features. Alone, each is economically marginal but together they are able to compensate for some of the shortcomings of the individual systems.

Most heat pump systems are forced to rely on ambient air as a heat source, since moderate temperature heat source reservoirs (like lake or ground water) are not generally available. At low ambient temperatures the heat pump coefficient of performance (COP) drops rapidly towards unity. It may further reduce to values less than unity if moisture in the outdoor air condenses and freezes on the evaporator coil, requiring a defrost operation.

The obvious shortcoming of most solar energy systems working along is their lack of space heating capability. Even more, the outlet temperatures of inexpen-

sive collectors are near the lower limit of usefulness for space and domestic water heating at acceptable efficiencies.

Combining the base solar system with the base heat pump may at least diminish all these problems. The collector, can serve as a source for the heat pump. No freezing problem would occur for this liquid source evaporator and the storage capabilities of solar systems enables the heat pump to operate at a more uniform rate over the day thus easing peaking problems. The collector radiation and convection losses would decrease since the heat pump can extract heat from the collector loop, resulting in higher collector efficiency.

Since the early days of solar research, there has been a continuous interest in heat pump and solar system combinations based on the idea that the purchased energy savings realized by the combined system will be greater than the savings from either system by itself. The purpose of this study is to examine closely the solar energy and heat pump systems which are the two promising systems for domestic space and water heating.

In this study, since we don't have a solar-assisted heat pump system installed yet in Turkey, three types of solar systems have been closely examined in two different

climates from the sources that have been obtained. Their advantages over the heat pump and the solar energy have been stated, the results and what to do to improve the efficiency have been discussed.

A stand-alone heat pump heating system does not appear to be an attractive investment for the present, since in our country both the electrical energy deficiency and high cost of electrical energy are unfavorable facts against application of heat pumps, and high initial investment is another disadvantage in hand. Various economic analysis have also shown that the heat pump, although less expensive than electric resistance heating, remains to be more costly than other conventional systems used.

On the other hand, since the performance of collectors is best at low temperatures, and the performance of heat pumps is best at high evaporator temperatures, a mixed solar/heat pump system, which is the objective of this study, is a promising alternative to investigate.

THE HEAT PUMP

1.1 WORLD ENERGY SITUATION

The vegetation and animal life for millions of years have produced, died and decayed and became stored in the form of coal, oil or peat, a growing accumulation of fuel that remained largely untapped. Only two centuries ago, the industrial age began initially in England and then throughout the western world. As nations developed into a more industrialization, the demand for energy increased. Till 1900, oil was only used for illumination purposes, the oil consumption for that year throughout the world was 21.1 million tons, whereas in 1969 this figure became 2 billion 135 million tons. As can be seen, the oil consumption between 1900 and 1969 increased by 100%, directly proportional with the new investigations that took place in those years. (1)

Figure 1.1. shows the increase in total energy demand from 1454 MM tons of oil equivalent (mtoe) in 1950 to 4,129 mtoe in 1973. The coal consumption barely changed and all the increase virtually was borne by oil, natural gas and primary electricity (hydro and nuclear). Besides the first reason given in the previous paragraph, the

rapid increase in oil demand mainly occurred because imported oil from the Middle East and North Africa became cheaper than natively produced energy. In 1973, OPEC (Organization of Petroleum Exporting Countries) suddenly increased oil prices, which consequently led to a reduction in demand for OPEC oil. Since then, the demand has recovered and is close to the 1973 figure shown in Table 1.1. Still today the price of OPEC oil determines the supply and price of energy in the world.

TABLE 1.1

Oil Production by Present Members of OPEC
(million tons/year)

1960	435
1965	720
1970	1175
1973	1555
1976	1530
1985	2000 (estimate)

Sources: BP, Petroleum Intelligence Weekly⁽²⁾

The Department of Energy suggests that the demand for OPEC oil in 1985 is most likely to lie in the range of 1500-2000 million tons per year,⁽³⁾ assuming that energy policies by consumer governments remain unchanged. It can easily be observed from Table 1.2 that oil is the closest source to exhaustion. By the year 2000, it is clear that oil will no longer be the major energy source. Nuclear energy or presumably coal will replaced oil in the near future.

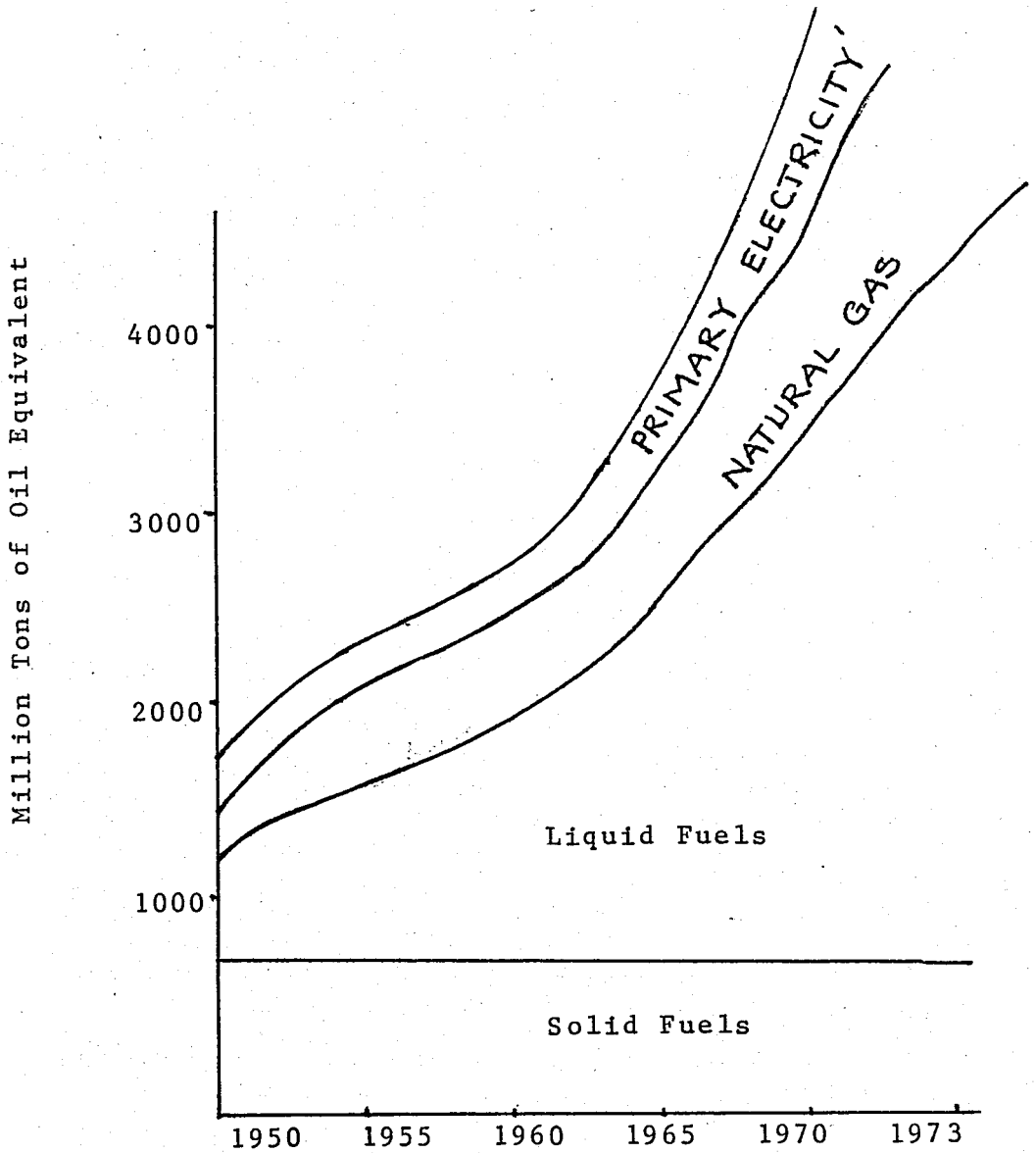

† Equivalent Fossil Fuel Input to Power Stations.
Assuming 35% Efficiency.

FIGURE 1.1. Primary Energy Consumption⁽¹⁾

TABLE 1.2

Total World Fossil Fuel Reserves
and Consumption(4)

Fossil Fuels	Proved Reserves (thousand mtoe)	1980 Consump (000 mtoe/yr)	Priced Reserves ÷ 1980 Cous.
Oil	80.4	2.7	30
Gas	56.5	1.1	50
Coal	32.9	1.9	175

The situation of world fossil fuel supply in 2000 is shown in Table 1.3. From these figures we can see that fossil fuels will not be sufficient to satisfy the world energy demand at the turn of the century.

TABLE 1.3

Fossil Fuel Supply in 2000 (btoe)^{*(5)}

	1980 Actual	D/Energy	WAES** High Demand	WAES Low Demand
Oil	2.2	3-3.5	3.6	3.0
Natural Gas	0.8	1	1.2	1.0
Solid Fuels	0.9	1.5-2	1.7	1.1
Total	3.9	5.5-6.5	6.5	5.1

* Billion tons of oil equivalent

** Workshop on Alternative Energy Strategies

As a conclusion, it seems that the world wide trend of energy policy will be based on the question of what should be the respective contributions of energy conservation, of coal, nuclear based electricity and of fuel imports to meeting the energy needs.

In the nation's energy plan there are three major points to be given attention. They are primarily, as an immediate objective, reduce dependence on foreign oil and vulnerability to supply interruptions. Secondly, in the medium term term, to keep imports low to sustain the period when the world oil production approaches its capacity limitation in 2020 without further discoveries. And thirdly, in the long term, to have renewable and essentially inexhaustible sources of energy to sustain economic growth. Energy resources which can be utilized in the next 100 years are unlimited solar energy, and coal, however environmental regulations and production plus transportation difficulties provide a constraint on the use of coal.

1.2. THE GROWTH OF HEAT PUMP APPLICATIONS

There is another point closely related to the fact that the world's fossil fuel reserves are limited - the growth of heat pump applications. The basic principle of the heat pump was first proposed by Nicolas Carnot in 1824. This theory was advanced 30 years later in 1952 when Lord Kelvin proposed that refrigerating equipment could be used for heating. Lord Kelvin outlined and designed a machine which he called a Heat Multiplier. This machine would heat a room to a higher temperature than the ambient temperature, by using less fuel in the

machine than if such fuel was burned directly in a furnace. Since then, the heat pump remained to be the researcher's curiosity. (2)

In the mid 1930's, in the USA, several manufacturers became interested in the possibility of developing cost-effective products based on the heat pump principle. Developments were made on heat pumps for residential and small commercial installations. Products of this type were offered for sale in quantity for the first time in 1952. (4)

From 1950 to the 1960's, the heat pump had its reputation tarnished by low product reliability and high service costs, for they lacked sufficient durability under cold weather conditions. In the 1960's, electric furnaces became attractive because of their lower first cost and higher reliability in the USA. During this period, improved designs of heat pumps were developed. This improved designs used refined components which were designed to withstand more severe heat pump stresses. In the 1970's, electric and oil prices started to increase, the oil crisis had started its beginning. Heat pumps became an alternative again for heating.

There are many reasons for the heat pump to take so long to exercise widely. Some of them are:

1. High initial costs.
2. No proven fuel-saving.
3. Refusal to accept that a machine can deliver more heat than the equivalent work input.
4. High Maintenance costs.

For the near future all projections show great growth in the use of water heating and for the residential heating. The value of the heat pump will increase in inverse proportion to the quantity of remaining fossil-fuel. In the USA, there is a downtrend in the utilization of scarce fuels such as natural gas and oil for comfort heating. Since the heat pump is the most cost effective electric heating system available, it appears to be the most reasonable alternative. (5)

But unfortunately, there are two other major and unfavorable facts against application of heat pumps, these are:

1. electrical energy deficiency
2. high cost of electrical energy.

The best solution for overcoming these facts is a "hybrid system" which integrates the cost effectiveness of the heat pump with improved levels of solar systems. (5,6)
Before going into the complexity of a hybrid, in other

words, combined solar heat pump systems, a brief explanation of what a heat pump is and how it operates will be made in this chapter.

1.3. HEAT PUMP AND ITS OPERATION PRINCIPLE

A large amount of heat is wasted through stacks of factories and exhaust air of buildings and processing plants. Energy can be saved by reducing the amount of this waste heat. And heat pump is one of the important alternatives for this waste heat recovery. A heat pump is basically a modified air conditioning system that has the flexibility to interchange functions between the evaporator and the condensor, allowing it to either heat or cool to desired space. It is a thermodynamic system which enables heat to be transferred from one medium to another which is at a higher temperature. It may also be defined as a device that operates as a thermodynamic cycle and utilizes mechanical energy to transfer thermal energy from a source at a lower temperature to a sink at a higher temperature. The major components are the compressor, condensor, the throttle valve and the evaporator.

The principle of the heat pump is similar to that of the Compression Refrigerator. But whereas the refrigerator extracts heat from a chamber by the evaporation

of the refrigerant and whereas lowers the temperature, the heat pump supplies heat to a room by condensation of a heat transfer medium. The phenomenon utilized for this purpose is that fluids which are under high pressure evaporate at a higher temperature than fluids under a lower pressure. (7)

The work of transporting the medium from low to high pressure is done by the compressor. It draws in the vapor and compresses it to the desired higher pressure. Then, in a condensor, the steam is condensed at that higher pressure and gives off heat in doing so. This condensation is effected by passing the vapor through pipes with water running around them. This water then receives the heat from the vapor of the condensing heat transfer medium. The water is heated up to about 60-70° and can be used as a second heat transfer medium to feed the radiators of a heating system. It cools in the radiators, and flows back to the condensor, where it is heated up again.

1.4. HEATING AND COOLING MODES

There is no difference between the principle of a heat pump for heating and a heat pump for cooling. The only difference between them is their application purposes.

For heating, the heat pump produces heat to the desired space in order to maintain it at a temperature higher than the ambient temperature. The greater part of this heat is derived from a medium at a lower temperature as illustrated in Figure 1.2.

For cooling, the heat pump maintains a given medium at a temperature lower than the ambient temperature by continuously absorbing heat from this medium. The heat extracted as a result is transferred to a warmer medium as illustrated in Figure 1.3. T_1 is the temperature of the refrigerant at the lower thermal level of the system and is lower than the temperature of the medium which is to be cooled. T_2 is the temperature of the refrigerant at the higher thermal level of the system and is higher than the temperature of the medium which is to be heated.

The energy balance of these two systems: $Q_2 = Q_1 + W$ shows clearly the main feature of the heat pump which is that it always provides more energy for heating than is used directly in driving it. In this thesis, single stage vapor compression cycle will be considered since that is the most widely used.

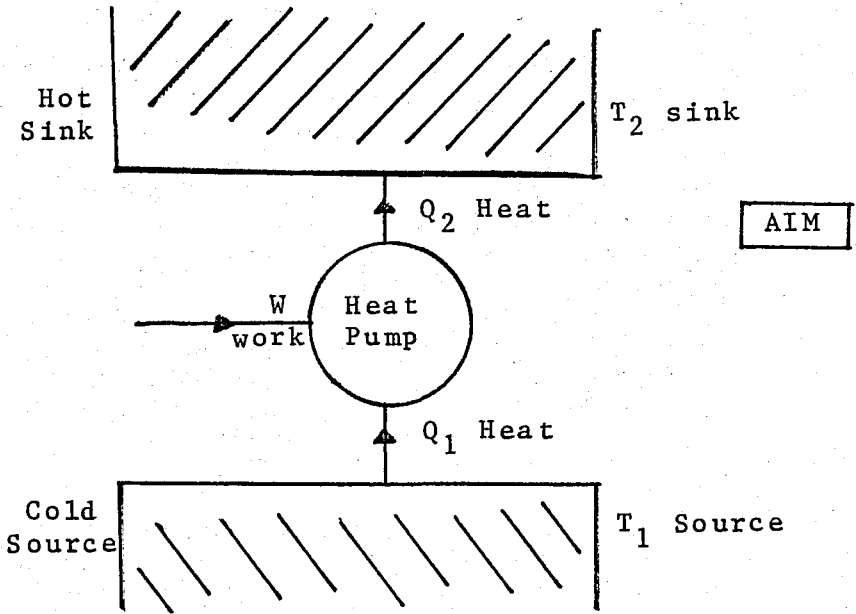

FIGURE 1.2. Heating by a Heat Pump

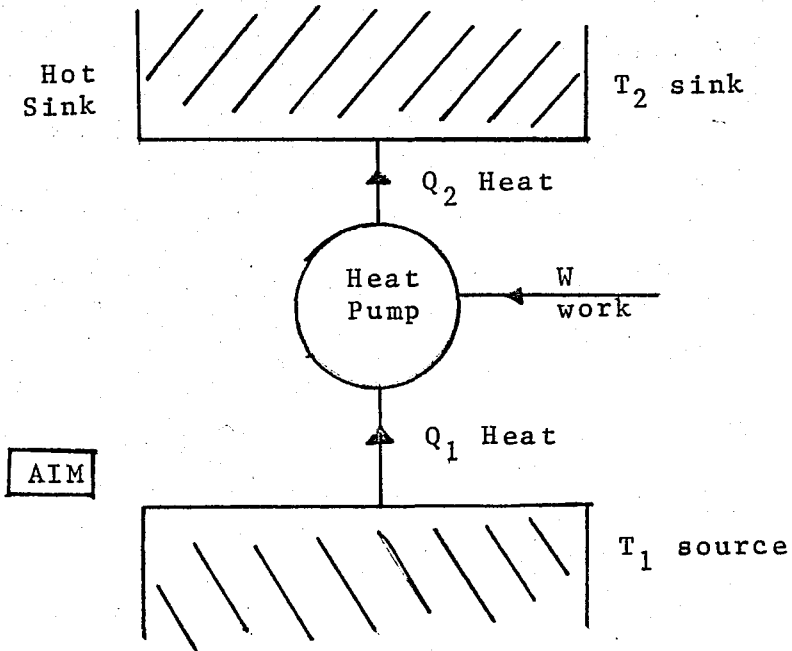

FIGURE 1.3. Cooling by a Heat Pump.

1.5. THE IDEAL VAPOR COMPRESSION CYCLE

The ideal vapor compression cycle, known as Rankine cycle, is illustrated in Figure 1.4. In the underlined cycle, the saturated vapor at low pressure enters the compressor and then undergoes an isentropic compression. Heat is then rejected at constant pressure in process 2-3, and the working fluid leaves the condenser as saturated liquid. Process 3-4 is an adiabatic throttling process and then the working fluid is then evaporated at constant pressure, 4-1 to complete the cycle. All the above explained processes are steady-state, steady flow processes. The first law of thermodynamics can be applied to analyze these processes.

$$p_1 v_1 + u_1 + q_{12} = p_2 v_2 + u_2 + w_{12} + KE_{12} + PE_{12} \quad (1)$$

where; enthalpy is

$$h = pv + u \quad (2)$$

so,

$$h_1 + q_{12} = h_2 + w_{12} \quad (1')$$

Applying the conditions of the above four individual process to equation (1') we obtain the following results:

* 1 - 2, compression process: $q_{12} = 0$

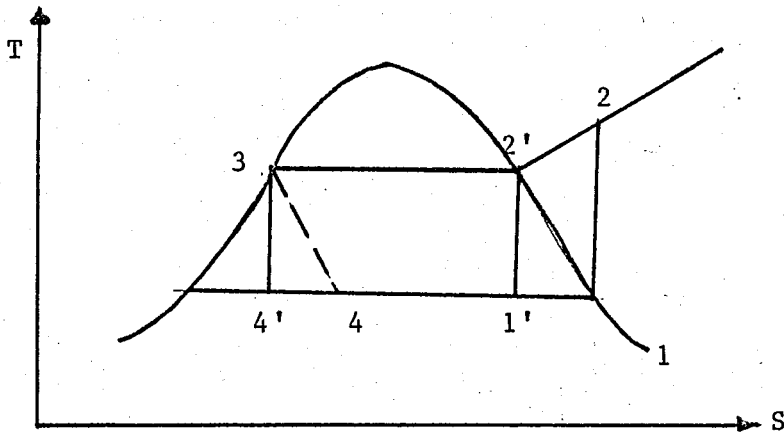
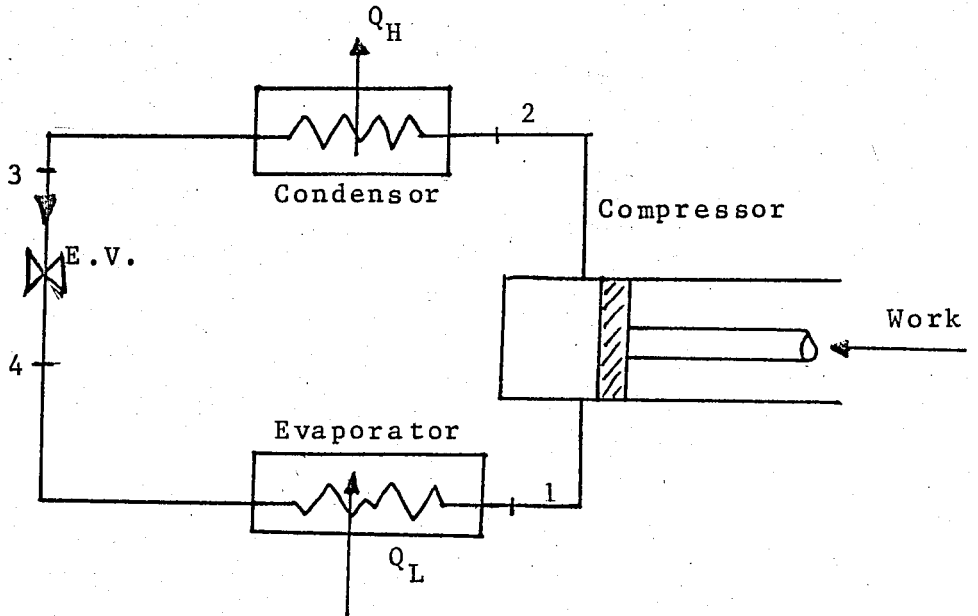

FIGURE 1.4. The Ideal Vapor Compression Cycle.
(Cycle 1' - 2' - 3' - 4' - 1' Carnot)

$$- w_{12} = h_2 - h_1$$

* 2 - 3, condensation process: $w_{23} = 0$

$$q_{23} = h_2 - h_3$$

* 3 - 4, throttle valve: $q_{34} = 0, w_{34} = 0$

$$h_4 = h_3$$

* 4 - 1, evaporation process: $w_{41} = 0$

$$q_{41} = h_1 - h_4$$

1.6. HEAT PUMP PERFORMANCE

In Figure 1.5, the thermodynamic principle of the heat pump is shown. T_1 is the temperature of the refrigerant at the lower thermal level of the system and is lower than the temperature of the medium which is to be cooled. T_2 is the temperature of the refrigerant at the higher thermal level of the system and is higher than the temperature of the medium which is to be heated.

The overall efficiency of a heat pump system is mostly dependent upon the performance of the compressor.

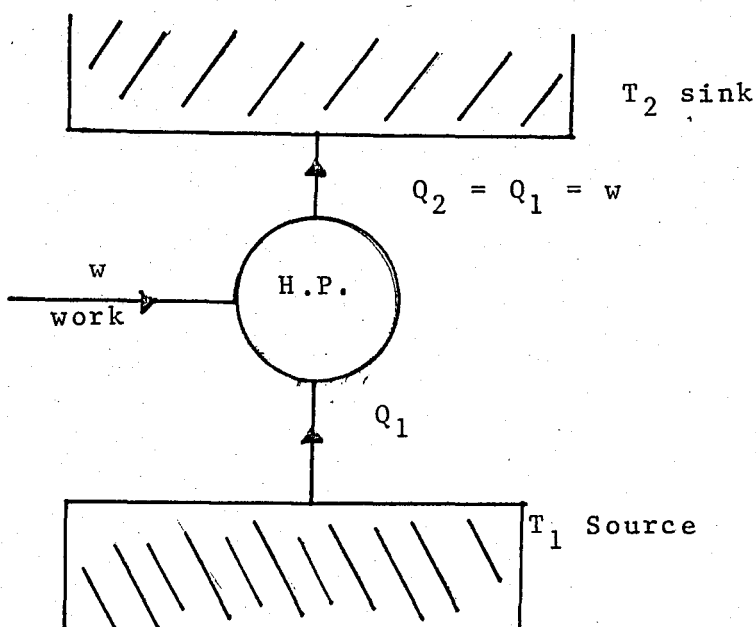

FIGURE 1.5. Thermodynamic Principle of Heat Pump.

The compressor size, the design of heat exchanger surfaces^(*), the refrigerant are all factors effecting the performance of the heat pump system. To achieve a high degree of performance, it is necessary to keep an optimum balance between these factors.

The most commonly used index of heat pump performance is the coefficient of performance. The COP expresses the effectiveness of a heat pump system. It can be defined as;

$$C.O.P. = \frac{\text{Useful heating or cooling effect}}{\text{Net energy supplied from external sources}}$$

(*) Heat exchanger surfaces (evaporator and condensor)

Energy supplied in mechanical compression systems is work whereas in absorption systems and ejection systems energy is mainly supplied as heat.

C.O.P. is defined for heating as the ratio of the heat Q_2 supplied by the heat pump at the heat sink to the energy w absorbed by the pump in order to perform this operation.

$$\text{C.O.P. Heating} = \frac{Q_2}{w} = \frac{Q_2}{Q_2 - Q_1} = \frac{Q_1 + w}{w} = 1 + \frac{Q_1}{w}$$

$$\text{C.O.P. Carnot Heating} = \frac{Q_2}{w} = \frac{Q_2}{Q_2 - Q_1} = \frac{T_2}{T_2 - T_1}$$

where:

Q_2 = Total heat output

Q_1 = Heat exchange in evaporator

w = Input electrical energy

T_1, T_2 = Absolute temperatures

It can be easily seen from above that the coefficient of performance is directly dependent on the evaporation and condensation temperatures. Efficiency of the heat pump will be higher, higher the cold source temperature T_1 , and lower the hot sink temperatures T_2 , because there will be smaller temperature difference T_1 and T_2 . Since, in residential heating, temperature dif-

ference between the required temperature of heat extracted and the temperature of heat given to the system is not great, the efficiency of the system is high. This makes residential heating the most important market for heat pumps.

At the same time, high temperature difference between T_2 and T_1 lead to high pressure conditions for the compressor, and consequently temperatures of discharge gas. The temperature difference that can be managed without risk of damage to the compressor varies with the type of the refrigerant used.

The COP of the Carnot cycle can never be achieved in practice, mainly because the ideal conditions of isentropic compression or expansion are not practically possible.

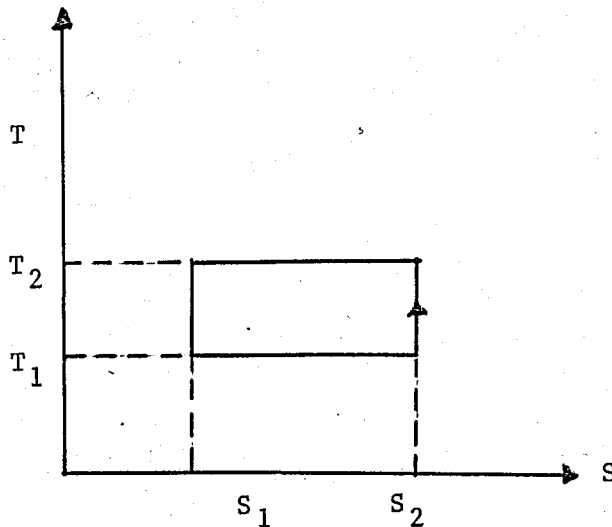

FIGURE 1.6. T-S Diagram of Carnot Cycle.

Other factors that influence this Carnot COP are:

1. Compressor engine efficiency.
2. Heat loss from compressor to ambient air.
3. Pressure drops in the refrigerant lines.
4. Temperature gradients for the heat transfer from the refrigerant to the heat source and heat sink.
5. The power of the fan which moves air over heat transfer surfaces.

On the other hand, the Rankine cycle, the ideal vapor compression cycle is more representative of the heat pump cycle. The COP of the Rankine cycle referring to Figure 1.4 is:

$$\text{COP Rankine} = \frac{q_{23}}{w_{12}} = \frac{h_2 - h_3}{h_2 - h_4}$$

where h_4 , h_2 and h_3 represent the enthalpy of the vapor before compression, after compression and after expansion respectively. Tabular or graphical values of enthalpy for the refrigerant are essential for the determination of the Rankine cycle performance. The Mollier (pressure - enthalpy) chart is the most convenient shown in Figure 1.7.

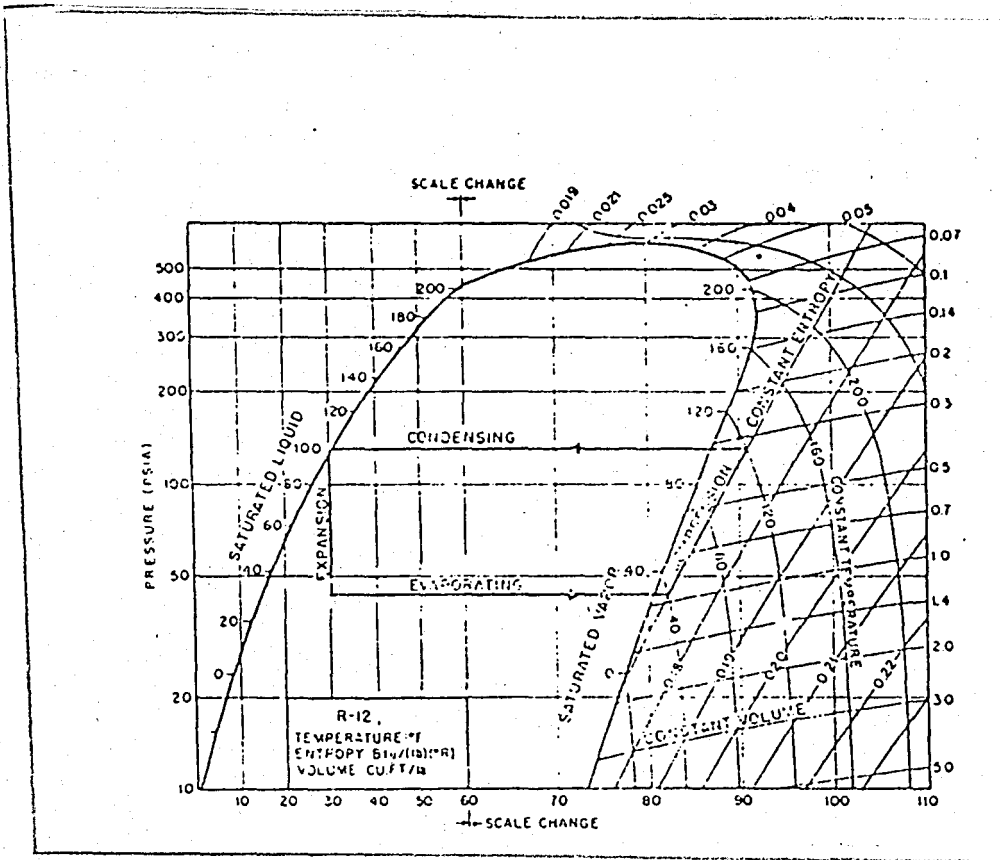

FIGURE 1.7. P-h Diagram of Rankine Cycle.

The Rankine COP is lower than the Carnot COP, but it is still greater than the COP of an actual heat pump because in practice there are pressure drops associated with the fluid flow and heat transfer to and from the surroundings which are not taken into consideration in the Rankine cycle.

A comparison of the COP at various air heat source and heat sink temperatures for the Carnot cycle, the

Rankine cycle and an actual heat pump unit is shown in Figure 1.8.

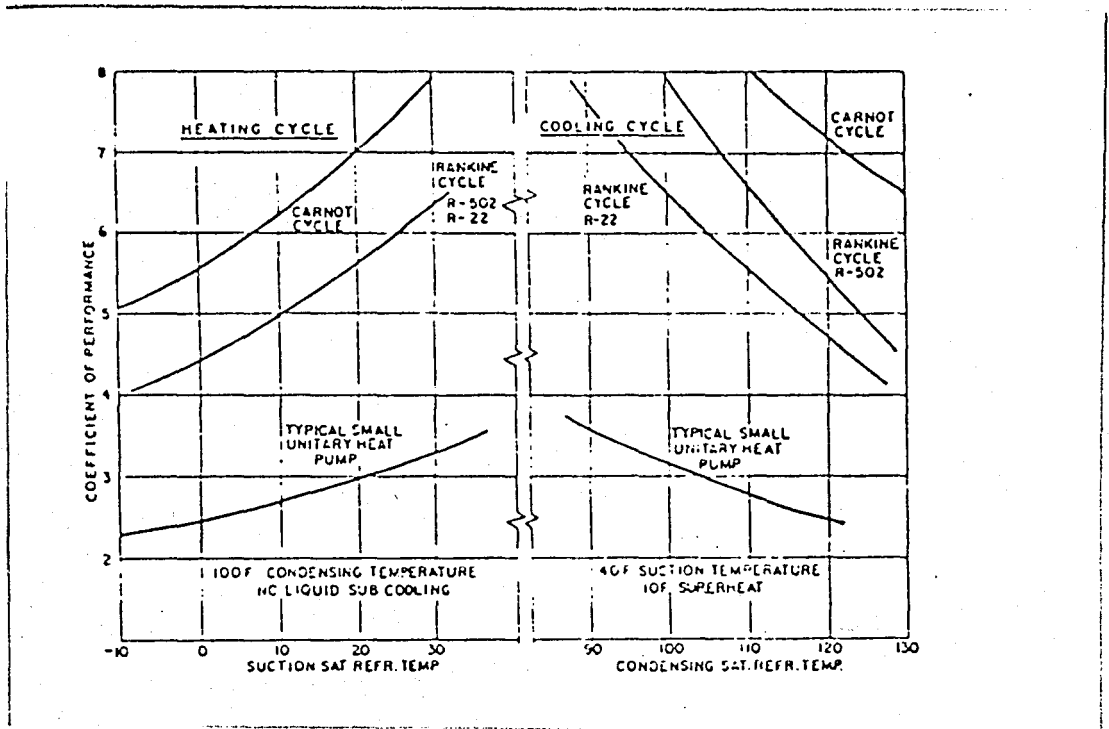

FIGURE 1.8. COP at Various Refrigerant Temperatures. (10)

CHAPTER 2

CHAPTER 2

2.1. CLASSIFICATION OF MAJOR HEAT PUMP DESIGNS

A systematic classification of the different types of heat pumps is difficult, because the classification can be made from numerous points of view, such as the ways of extracting heat from the environment to the cold source, by types of heat carrying media in cold source side and in hot sink side, ⁽²⁾ etc.

Heat pump systems classified according to the ways of extracting heat from the environment to the cold source are:

- a) Heat pump systems extracting heat by vaporizing a liquid refrigerant are:
 - 1. Compression heat pumps; the refrigerant is moved by way of a compressor.
 - 2. Absorption heat pumps; the refrigerant is moved by the circulation of a suitable absorbent solution.
 - 3. Vapor-jet heat pumps; the refrigerant is moved by an ejector.

- b) Heat pump systems extracting heat by the expansion of compressed gas.
- c) Thermo-electric heat pump systems.

Heat pump systems classified according to the types of heat carrying media in cold source side and in hot sink side are:

- a) Air to air heat pump
- b) Water to air heat pump
- c) Air to water heat pump
- d) Water to water heat pump
- e) Earth to air heat pump
- f) Earth to water heat pump

Another usual classification differentiates between, (8)

- a) primary heat pumps which utilize a natural heat source present in the environment, such as external air, soil, ground, water, surface water.
- b) secondary heat pumps which re-use waste heat as heat source, e.g., already used heat, such as extracted air, waste water, waste heat from rooms to be cooled.

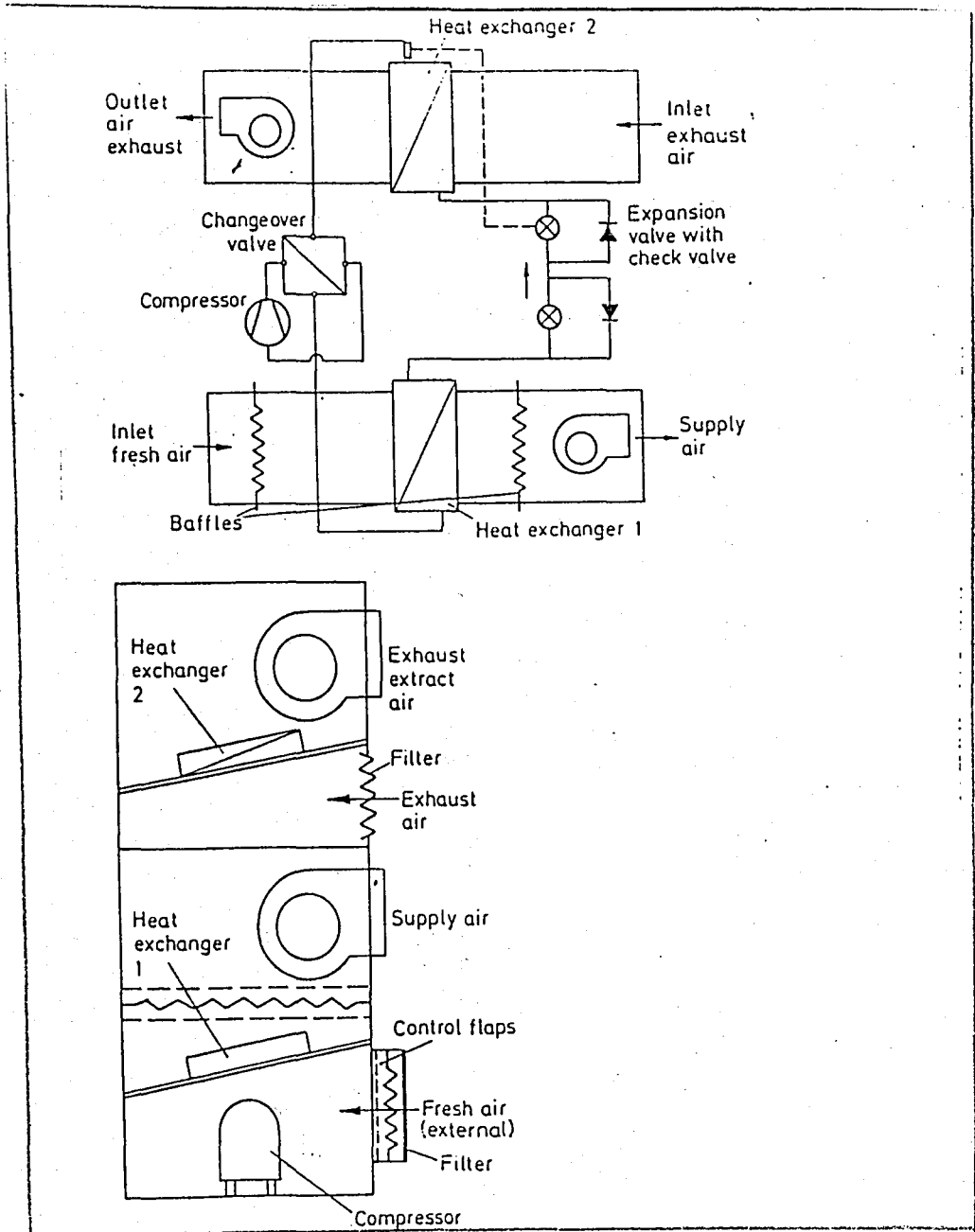

FIGURE 2.1.a. Schematic Diagram of an Air/Air Heat Pump.

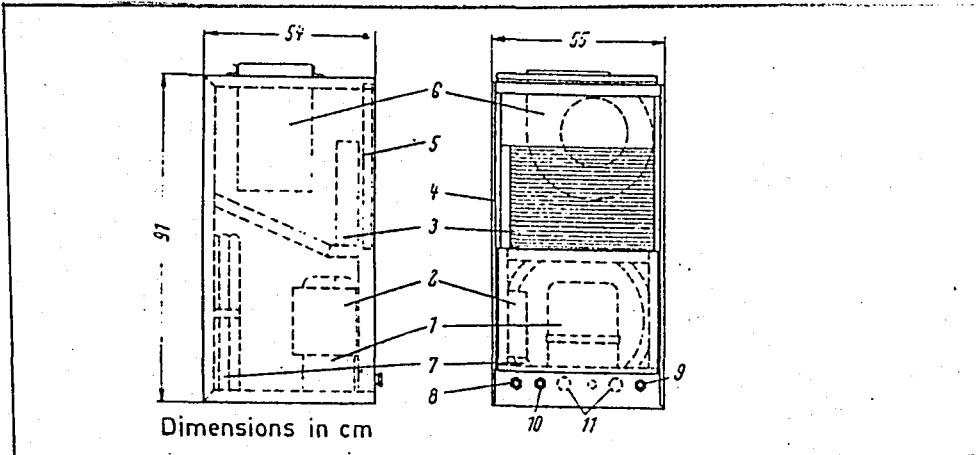

FIGURE 2.1.b. Water/Air Heat Pump of Messrs Typhoon.

1. Compressor
2. Terminal box
3. Air heat exchanger
4. Control panel
5. Air filter
6. Fan
7. Condenser-evaporator
- 8/9. Water connections
10. Condensate water outlet
11. Electrical connections

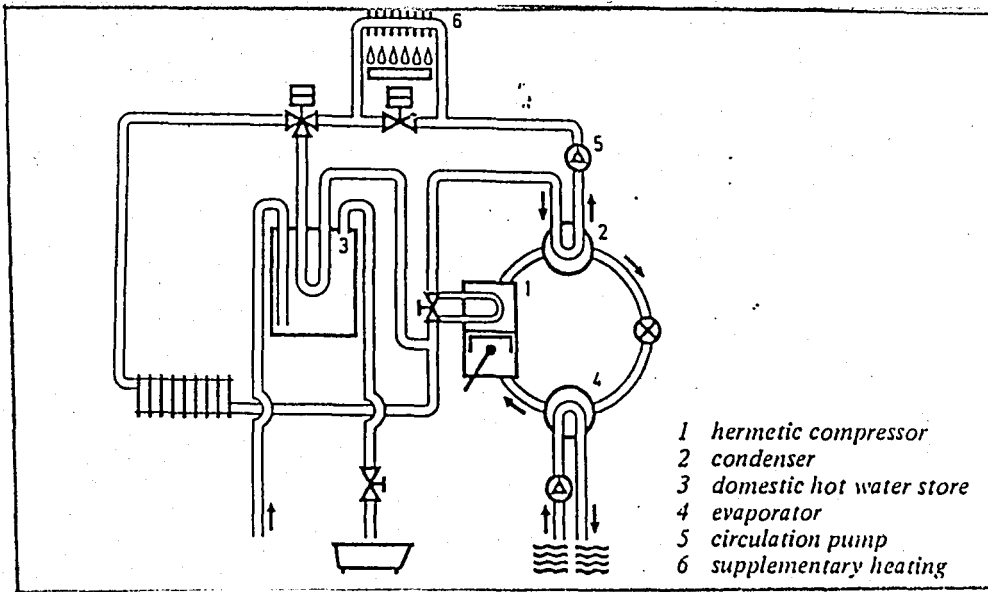

FIGURE 2.1.d. Diagram of a Water/Water Heat Pump of Messrs Bosch-Junkers.

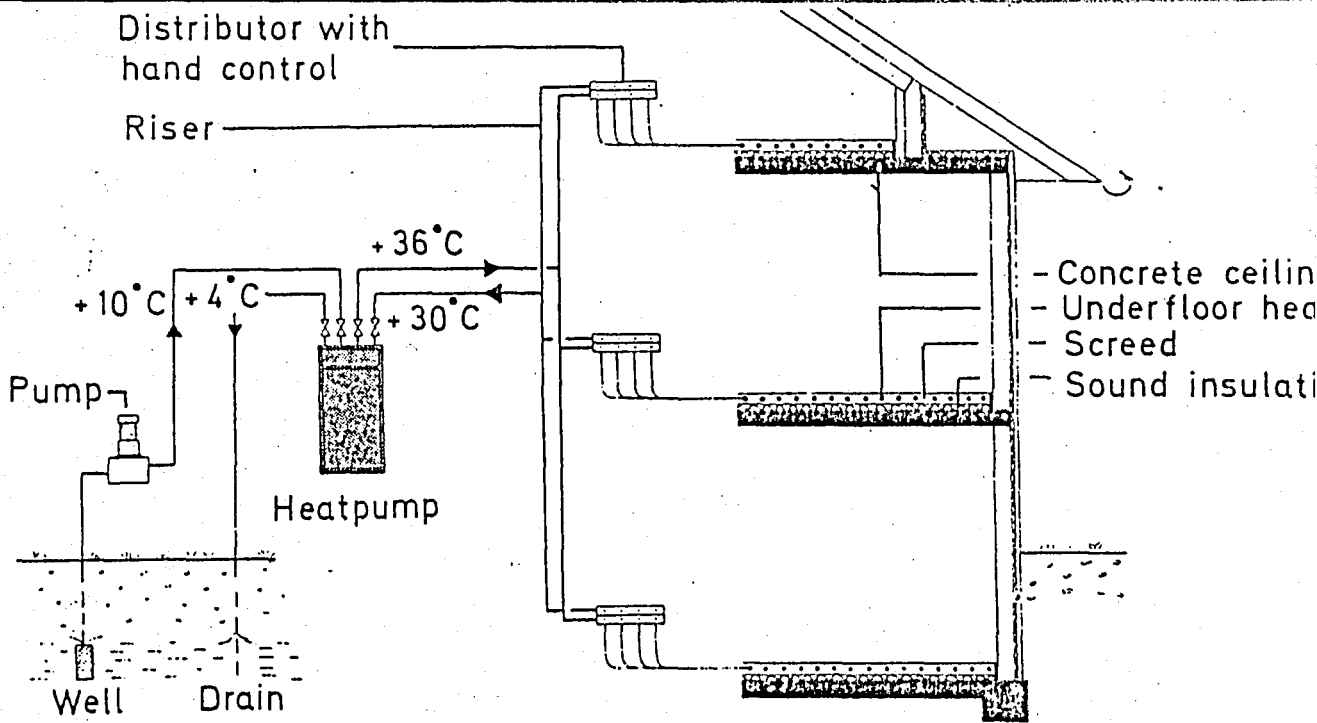

FIGURE 2.1.e. Diagram of a Water/Water Heat Pump With Ground Water as Heat Source and Under-floor Heating.

- c) Tertiary heat pumps, which are in series with a primary or secondary heat pump in order to raise the achieved, but still relatively low temperature further, e.g., for hot water preparation.

2.2. APPLICATION AREAS OF HEAT PUMP SYSTEMS

Heat pump systems have a wide range of applications, from connected loads of a few watts for a thermoelectric heating/cooling unit, to loads of several megawatts for large vapor compression plants in industry. Some of the major areas of use may be classified as follows:

1. District heating
2. Residential heating
 - single family houses
 - apartment buildings
3. Commercial building heating
4. Industrial heating
 - Process cooling and refrigeration
 - Process heat
 - Space heating
5. Specific heating
 - school heating
 - hospital heating
 - swimming pool heating

- offices
- department stores, etc.

For district heating, the heat extracted from the condensor of the heat pump system should be at a high temperature level, which indicates a lot of work to be applied. There will be heat losses in the distribution and the cost of heat distribution will be high. So the system is expected to be inefficient and less economical than heat pump systems for residential heating. The heat pumps are used to evaluate the temperature level of available heat which is a bit below the required level. So district heating may be economical only if waste steam or hot water is available. For district heating, absorption heat pump systems recovering waste steam in thermal power plants can be used.

Residential heating is the most important market for heat pumps, since economics of a heat pump system is directly related with the efficiency of the heat pump, and in residential heating, temperature difference between the required temperature of heat extracted and the temperature of heat given to the system is not great, the efficiency of the system is high. Vapor compression heat pumps are quite appropriate for this purpose, whereas residence heating by absorption heat pump is not very economical since great amounts of high grade heat is

needed and in residences waste steam and waste hot water are not available, so the only sources left are solar energy and air for an absorption heat pump, but the temperature level of air and solar heated water is not visually high enough.

It is also noted that the major part of the gross energy consumed in the residential sector is consumed through water heating, which ranks the second position after space heating. It is apparent that the substantial domestic water heating requirements will have great significance both from the energy management and heat pump system design viewpoint. Therefore, domestic water heating must be an integral part of a heat pump system. The choice of a suitable heat source for the heating cycles is important for good heat pump performance. It should also be noted that the heating made - either for space heating or for domestic water - is very suitable for Turkey climate, it does not experience extreme temperatures and therefore does not have to cope with the cooling load. Among the heat sources for the above two purposes the following may be chosen:

- air
- water
- ground
- solar

In commercial building heating, heat demands will be greater during the day time compared to the residential heat demands depending on application scale. During the night time, where heat sources are not favorable, there is no heating load, so the efficiency of the system is greater.

In industrial plants, waste steam or waste hot water is usually available. If heat transferred from waste steam or waste hot water is sufficient so that no external sources are used to supply additional energy, direct applications are very economical. But if the above mentioned statement is not fulfilled, heat pump should be used to evaluate the temperature level of the heat. Absorbtion heat pumps can be used more economically if there is no heat recovery system in the industrial plant. Utilization of vapor compression heat pumps in industrial heating, is limited by breakdown temperatures of good refrigerants and the availability of proper compressors of high temperatures. Within limits, compression heat pumps driven by steam turbines can be considered.

Heating of swimming pools, hospitals and other similar constructions have favorable conditions for heat pump applications because of reduced load requirements at night. Residential heat pump systems can easily be

adapted to such applications.

2.3. TYPES OF HEAT PUMPS

2.3.1. Operation of Vapor Compression Machine

The vapor compression machine consists essentially of the compressor with drive motor, evaporator, condenser and expansion valve. These components are connected to the system by pipes (Figure 2.2.) in which refrigerant with suitable thermodynamic properties circulates.

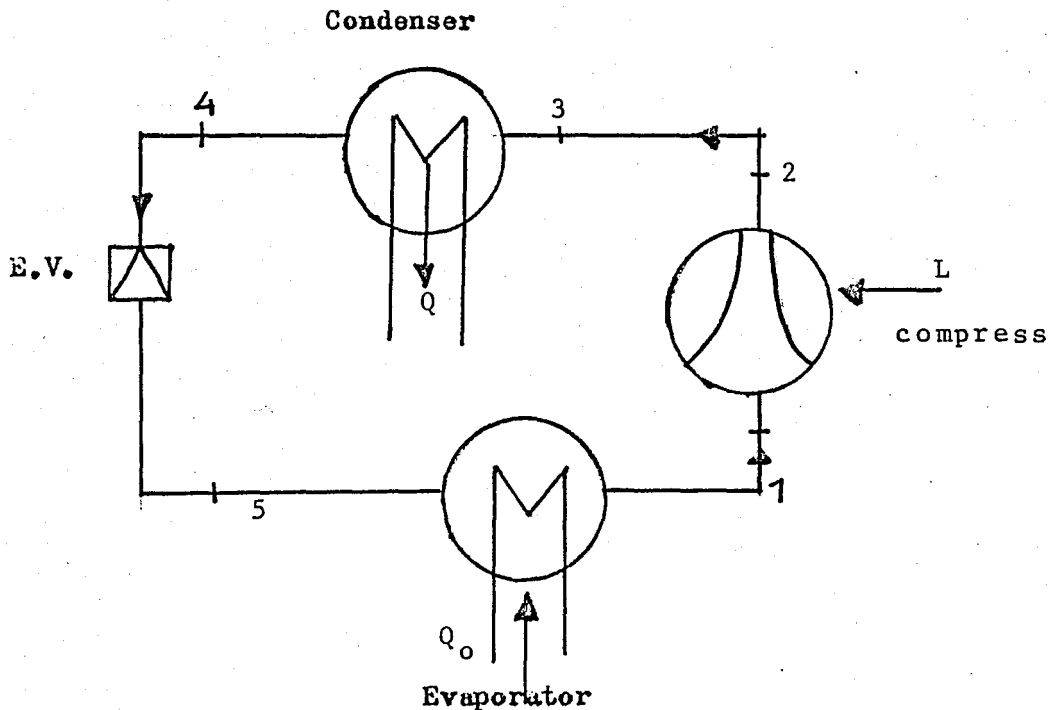

FIGURE 2.2. Diagram of a Compression Heat Pump.

This refrigerant is kept at such a pressure in the vaporator that the evaporating temperature t_0 is below the temperature of the medium to be cooled. Because of the temperature difference, heat flows into the evaporator and the refrigerant evaporates whilst absorbing heat. The resulting vapor is drawn off by the compressor and compressed to a pressure such that the condensing temperature t at this pressure is above the temperature of the medium to be heated. Because of the temperature difference, heat is extracted from the condensor and all the refrigerant vapor condenses whilst discharging heat. The liquid refrigerant is expanded in an expansion valve to the low evaporating pressure, and can thus absorb heat again in the evaporator, the cycle is closed.

REFRIGERANTS

The main refrigerants which are now used in heat pumps are listed in Table 2.1, together with the following important properties, related to a condensing temperature of $+50^{\circ}\text{C}$ and an evaporating temperature of 0°C :

- a) The ideal COP as a theoretical value,
- b) The volumetric heat output q_{HV} , which is defined as the ratio of the heat flow Q at the condensor to the volume flow V_0 delivered by the compressor.

$$q_{HV} = \frac{Q}{V_o}$$

- c) The condensing pressure p at a condensing temperature of $+50^{\circ}\text{C}$. The higher the pressure, the more expensive are the components which have to withstand this pressure.
- d) The pressure ratio p/p_o of the condensing pressure at $t = +50^{\circ}\text{C}$ and the evaporating pressure at $t_o = 0^{\circ}\text{C}$. The higher this ratio, the poorer the volumetric efficiency of the compressor.

TABLE 2.1.

Parameters of Various Refrigerants at a Condensing Temperature of 50°C and an Evaporating Temperature of 0°C

Refrigerant	Ideal COP	Volumetric Heat Output q_{HV} (kJ/m ³)	Pressure Ratio p/p_o	Condensing Pressure (bar)
R11	5.53	443	5.88	2.4
R12	5.16	2290	3.96	12.2
R12B1	5.74	1075	4.75	5.6
R21	4.64	636	5.68	4.0
R114	4.61	784	5.06	4.5
RC318	4.53	1163	5.12	6.7
R502	4.35	3676	3.68	21.1
NH ₃	5.53	4275	4.96	20.6

It follows from Table 2.1 that, generally;

- a) refrigerants with low vapor pressure (e.g., R11, R12B1, R114) have a small volumetric heat output and therefore require a large compressor throughput volume for a given heat output.

- b) refrigerants with a high vapor pressure (e.g., R22, R502, NH_3) have a relatively high volumetric heat output and therefore for the same heat output require a much smaller compressor throughput volume.

Some characteristics of different refrigerants are given below.

NH_3 (Ammonia)

Ammonia is important for large plants (industry) and will probably remain so.

NH_3 has excellent thermodynamic features with a favorable effect on, amongst others, heat transfer, filling capacity and pipe cross sections. It can be seen in Table 2.1. that the volumetric heat output for NH_3 is larger than for all other refrigerants mentioned. The COP is high too. The disadvantages are: high condensing pressure, toxicity and the danger of an explosion when a large proportion of NH_3 is mixed with air. The pungent smell, however, provides a special warning. For home heating and buildings frequented very much by the public, NH_3 must be excluded because of the danger which might be caused by panic and poisoning.

FLUORINATED HYDROCARBON REFRIGERANTS

This group contains numerous refrigerants which are distinguished by the letter R and a first figure indicating the basic hydrocarbon, the non-substituted hydrogen atoms and the last position giving the number of fluorine atoms.

The most important R refrigerants are:

R12, best proven and most used R refrigerant. R12 requires a 60% larger stroke volume of the compressor than R22. The pressure and operating temperatures are much lower with R 12 than R22. R12 permits operating with relatively low evaporating temperatures as well as with high condensing temperatures. R12 can readily be mixed with lubrication oil used in refrigeration machines.

R22, is the most common refrigerant in the USA. The ideal COP is relatively high, the volumetric heat output is the best after NH_3 . The condensing pressure at 50°C is 19.3 bar which is rather high.

R502, this refrigerant can be well recommended for heat pumps. Its main disadvantage is the high operating pressure, which is 21.1 bar at 50°C . One particular characteristic is its low operating temperature which

is favorable for the stability of the oil and the motor insulation and therefore of advantage for the service life of the machine. The volumetric heat output is nearly as high as R22 and approximately 60% higher than R12; the ideal COP however, is considerably lower than R22 and R12. At lower evaporating temperatures (below -10°C), the achievable heat output compared with R22, and particularly with R12, increases. R502 is therefore suitable for heat pumps with external air as heat source.

R114, is a low pressure refrigerant suitable for heat pumps with high evaporating and condensing temperatures. The volumetric heat output is approximately 3 times lower than R12 and 4.8 times lower than for R22. The compressor throughput has to be correspondingly large.

R11, in practice, is only suitable for centrifugal compressors. Reciprocating compressors would have to be very large because of low volumetric heat output. Because of low vapor pressure, machines filled with R11 operate at evaporating temperatures below 123.8°C in a vacuum. Even at 50°C the condensing pressure is only 2.4 bar.

R21, is a low pressure refrigerant. The low volumetric heat output seems to make it suitable only for use in turbo-compressors.

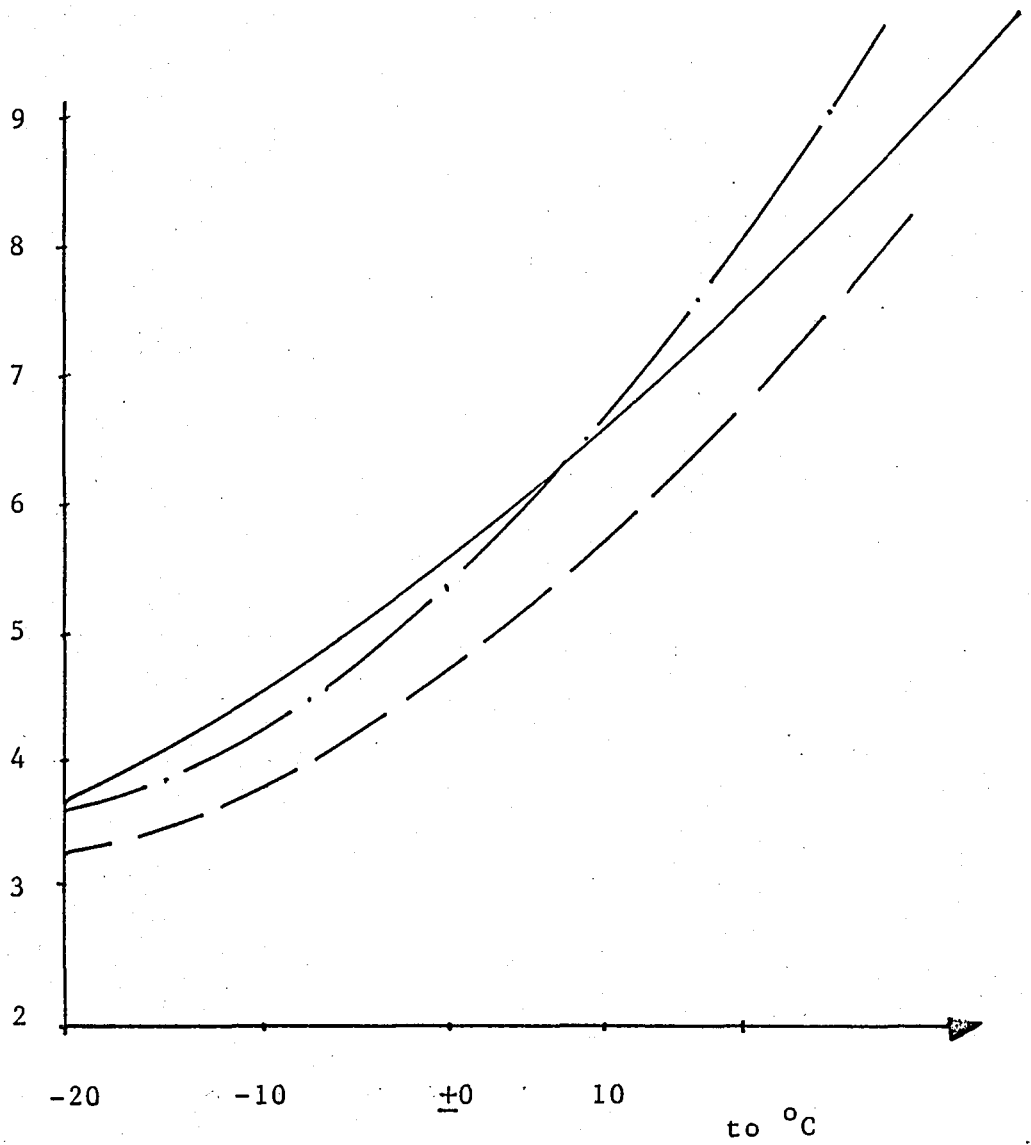

FIGURE 2.3. COP for Vapor Compression Heat Pumps.

2.3.2. Operation of the Absorption Heat Pump

In absorption heat pumps, heat absorption takes place by evaporation at a lower temperature and heat release by condensation at a higher temperature. An expansion valve, as in the vapor compression plant, is used for the expansion from condensing pressure to evaporating pressure. However, the compression process, and thus the addition of exergy, is carried out by a thermodynamic system without a mechanical compressor.

The drive of an absorption heat pump consists of a circuit in which the refrigerant is absorbed by the absorbent at a lower pressure and is separated again from it, by adding heat, at a higher pressure and returns into the 'normal refrigeration cycle'.

The solution pump is the only mechanically driven component in the circuit. The main exergy input into the heat pump refrigeration circuit takes place by adding heat at a temperature above the condensing temperature. In this way, energy, in the form of heat and not in the form of mechanical energy, is put into the system. The added energy not only consists of exergy but also consists of a proportion of energy which is dependant on the temperature of the heating medium.

Figure 2.4 shows the circuit of an absorption heat pump. Condenser, expansion valve and evaporator, the three components of the conventional refrigeration, are retained. The drive has been replaced by a circuit comprising an absorber, solution pump, generator and expansion valve.

Leaving the evaporator, the refrigerant is absorbed by the absorbent in the absorber, releasing heat. In this mixture, the evaporation pressure has become the partial pressure of the refrigerant. The solution is brought up to the pressure in the generator by a pump. Part of the refrigerant is separated from the solution and passes into the condenser by additional heat. The solution, depleted of refrigerant is expanded to the pressure of the absorber by an expansion valve and can again absorb the refrigerant.

The energy flows that take place in an absorption heat pump are:

1. Heat addition for generator heating at temperature, t_{gen} ,
2. Drive power for solution pump.
3. Heat release in condenser at temperature, t_{cond} ,
4. Heat input to evaporator at the temperature t_0 .

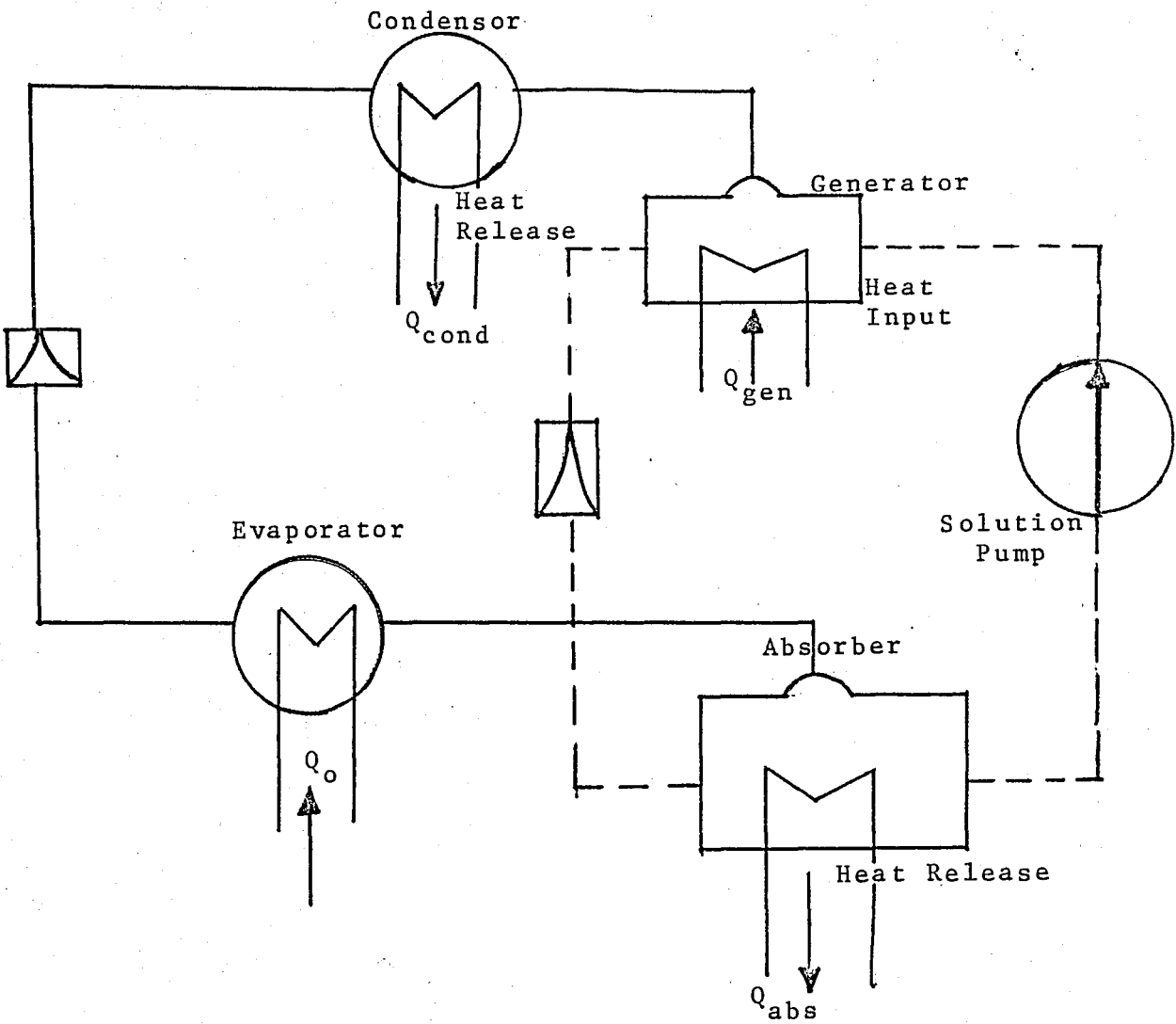

FIGURE 2.4. Schematic Diagram of an Absorption Heat Pump.

5. Heat release in the absorber at t_{abs} .

As a conclusion, an absorption heat pump releases heat at two points. The heat quantities, released by the absorber and the condensor occur at different temperatures and should therefore be used at different temperatures as far as the particular application of the heat pump permits. $t_m = t_{cond} = t_{abs}$ is assumed for simplicity.

WORKING FLUIDS

Working fluids are those pairs of fluids which consists of the actual refrigerant and an absorbent which absorbs the refrigerant.

Some important requirements for refrigerants and absorbents are given below:

- a) Condensing pressure not too high, evaporating pressure, if possible, not below the ambient pressure.
- b) Highest obtainable evaporating enthalpy.
- c) Low viscosity
- d) Good heat transfer values
- e) Flat-topped vapor pressure curve,

for absorbents:

- a) lowest obtainable vapor pressure.
- b) low solidification point.
- c) high density (influence on power input of the pump)
- d) low specific heat capacity
- e) low viscosity
- f) low solution enthalpy
- g) low surface tension
- h) good heat transfer values.

Absorbents and refrigerants must be chemically stable by themselves, and as a pair, for all the conditions occurring during operation, they should have no corrosive effect on the plant components and should be non-toxic, harmless and non-flammable.

Of the working fluids, the main refrigerants are:

- water
- ammonia
- amines
- flour-chlorine derivatives of hydrocarbon
- alcholes
- other hydrocarbons

2.3.3. Vapor Jet Heat Pumps

In the vapor jet heat pump, the kinetic energy produced by heat input of a vapor jet, is utilized for compressing the refrigerant vapor. In principle, this is a compression process which is operated without input of mechanical energy.

The vapor heat pump is seldom used in real applications.

2.3.4. Gas Cycle Heat Pumps

In gas cycle heat pump systems, the state of the working fluid does not change. The refrigerating and heating effects are due to the expansion or compression of the gas. The components of the system are a low-pressure heat exchanger, a compressor, a high-pressure heat exchanger, a turbine, and an engine.

The COP of such heat pumps are considerably lower than those of vapor compression heat pumps and absorption heat pumps, so that they are used in specific cases where they give decisive advantages.

2.3.5. Thermo-Electric Heat Pumps

The basis of a thermoelectric heat pump is the thermocouple, consisting of different electrical conductivity (p and n conductors) linked by a metal bridge. If a voltage is applied to the thermocouple and an electric current flows then, depending on the direction of the current, the bridge is either cooled or heated in proportion to the current; heat is thus pumped from the cold to the warm joint.

Transporting the heat to and from the joints, must be carried out through heat conductors and heat exchange surfaces. This increases the required temperature difference between the cold and the warm joints with a corresponding decrease in the COP. The thermocouples are arranged in series corresponding to the intended voltage and in parallel corresponding to the required current.

Transporting the heat to and from the joints must be carried out via heat conductors and heat exchange surfaces. This increases the required temperature difference between the cold and the warm joints with a corresponding decrease in the COP. The thermocouples are placed in series corresponding to the intended voltage and in parallel corresponding to the required

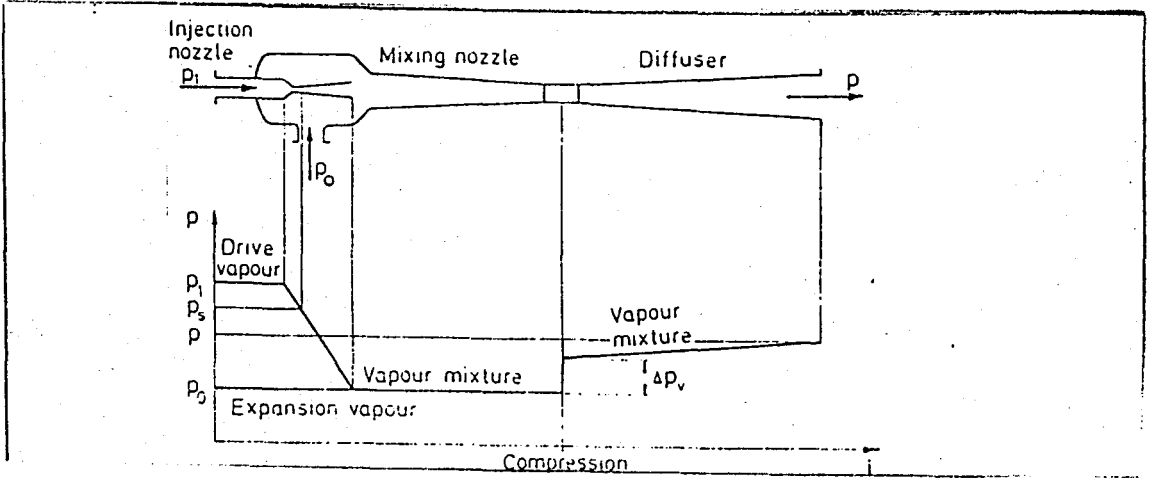

FIGURE 2.5. Diagram of a Vapor Jet Compressor.

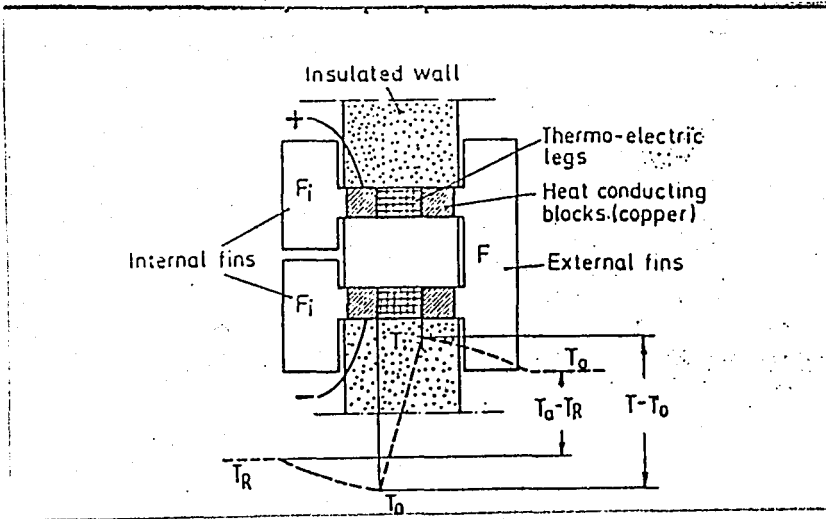

FIGURE 2.6. Schematic Diagram of a Thermoelectric Heat Pump.

current.

In the 1960's, thermoelectric refrigeration was given much consideration, similar to that given to photoelectric solar cells today. It is impossible, that the development of semiconductors' will receive a new impetus and that, particularly in connection with solar collectors, the thermoelectric heat pump will become a subject of renewed interest.

CHAPTER 3

.....
SOLAR ENERGY AS THE
.....
HEAT SOURCE

CHAPTER 3

3.1. CONVENTIONAL SOLAR WATER HEATER

A simple solar water heating system which employs natural circulation is drawn schematically in Figure 3.1. As the temperature of the water in the collector rises, its density decreases and so a circulation is established and the water in the tank is progressively heated. Usually a small electric pump is incorporated in the circuit which enables the storage tank to be placed in any convenient location.

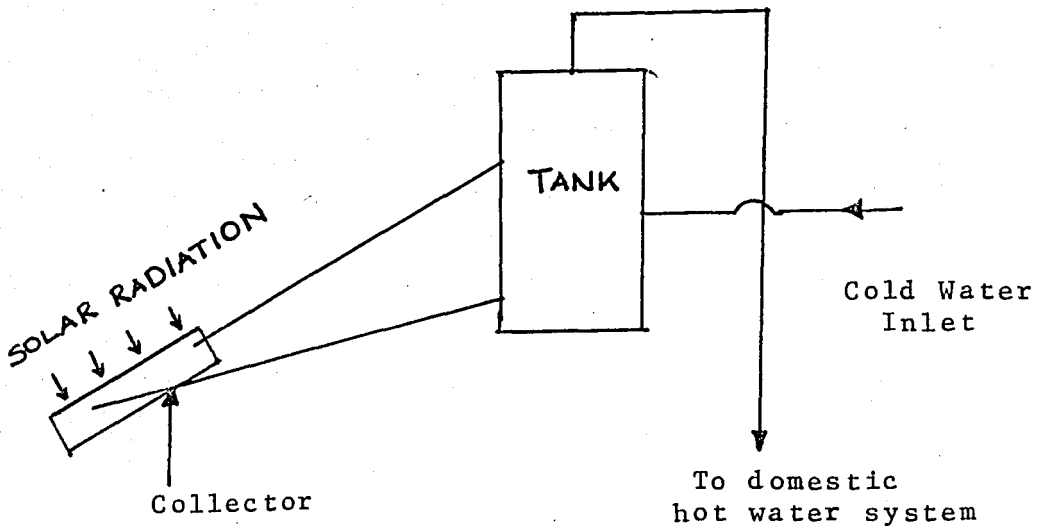

FIGURE 3.1. Simple Solar Collection System.

The cross section of a typical collector panel is shown in Figure 3.2. Most of the radiation incident on the panel is transmitted through the glass and falls on the metal plate, raising its temperature. The heat then radiated by the plate is largely trapped by the glass since glass is opaque to long-wave radiation. Nevertheless, some heat is lost both by conduction through the insulation and by radiation and convection from the front surfaces of the glass and the remainder is transferred to the water which flows in contact with the metal plate. The efficiency of a collector falls off approximately linearly as the difference between the collector inlet temperature and the air temperature rises.

A typical efficiency curve is shown in Figure 3.3. Collector efficiency is also a function of the incident radiation, clearly a hot collector would gain useful heat on a day of high radiation, whereas on a dully day it would lose more heat than it gained. Because of these limitations on collector efficiency, a normal domestic hot water temperature of 55°C can be achieved, e.g., in the U.K. only a few days in any year, whereas in zones where Turkey and the rest of the Mediterranean countries are located, during the summer this is the normal average temperature, and some form of supplementary water heating is not needed for this system. Supplementary water heating is needed in the UK where the average ef-

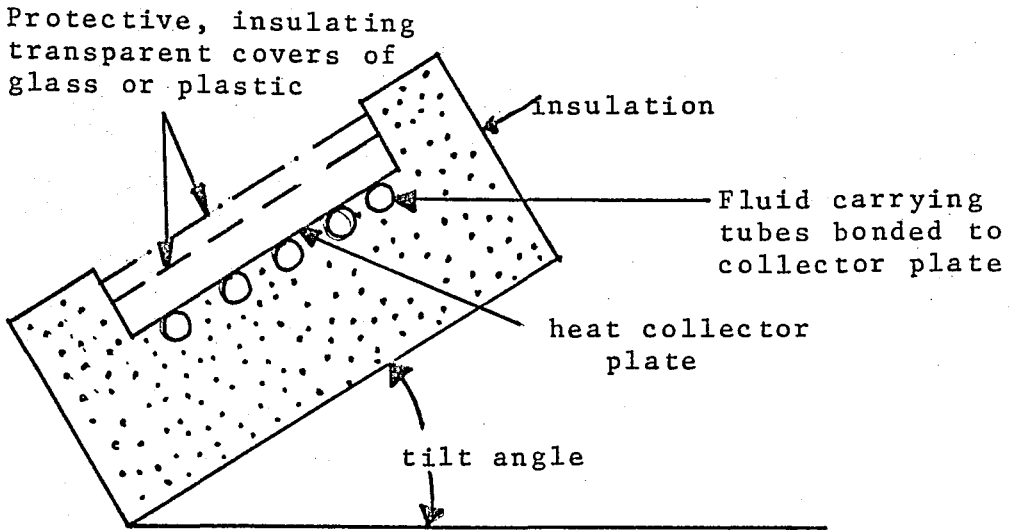

FIGURE 3.2. Basic Plate-Plate Solar Collector.

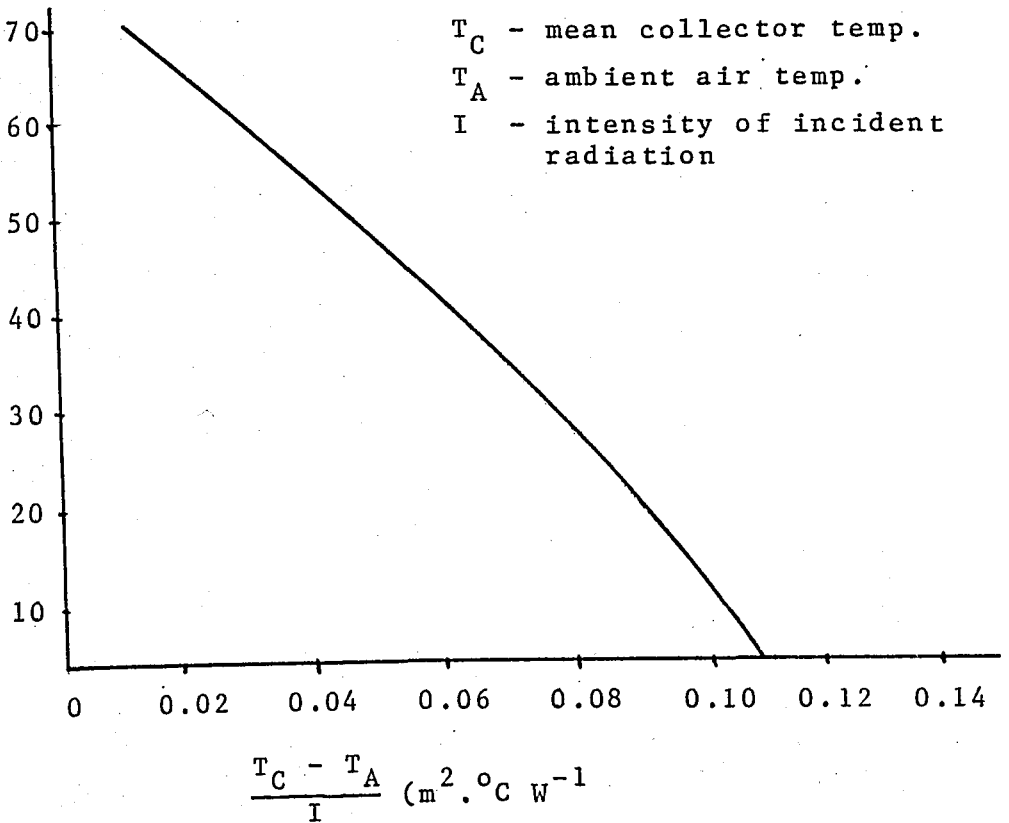

FIGURE 3.3. Typical Efficiency Curve for Single Glazed Collector

iciency of a collector panel over the year is expected to be around 40 percent.

Storage tanks and the piping from collector to tank must be well insulated. Piping runs should be as short as is practical.

Freezing is a problem which may occur in the collector in winter if a direct system such as that shown in Figure 3.1 is employed. This can be avoided by using antifreeze solution in the collector and replacing the storage tank with an indirect cyclinder.

Common antifreeze liquids are ethylene glycol-water and propylene glycol-water solutions. Their physical properties are: ethylene glycol is toxic, as are some commonly used corrosion inhibitors, and many plumbing codes require the use of two metal interfaces between the toxic fluid and the portable water supply. This can be accomplished either by the use of two heat exchangers in series or by double-walled heat exchangers that can be either internal coils in the tank or external to the tank.

First, for freeze protection, ⁽⁹⁾ antifreeze solutions can be used in the collector loop with a heat exchanger between the collector and the storage tank. As

shown in Figures 3.4 and 3.5 the heat exchanger can be external to the tank or it can be a coil within the tank relying on natural circulation of the water in the tank for heat transfer. For either arrangement, the performance of the collector-heat exchanger combination can be treated by the F_R' method. A typical overall heat transfer coefficient for a coil in a tank is $600 \text{ W/m}^2\text{C}$.

Second, air can be used as the heat transfer fluid in the collector-heat exchanger loop of Figure 3.4. Air heating collectors have lower $F_R(\tau_\alpha)$ and $F_R U_L$ than liquid heating collectors. However, no toxic fluids are involved, no second heat exchanger interface is needed, leakage is not critical, and boiling is not a problem.

The third method of freeze protection is to circulate warm water from the tank through the collector to keep it from freezing. Thermal losses from the system are significantly increased, and an additional control mode must be provided. This method can only be used in climates where freezes are infrequent. In emergencies when pump power is lost the collector and piping subject to freezing temperatures must be drained.

The fourth method is based on draining water from the collector when they are not operating. Draining systems must be arranged so that collectors and piping

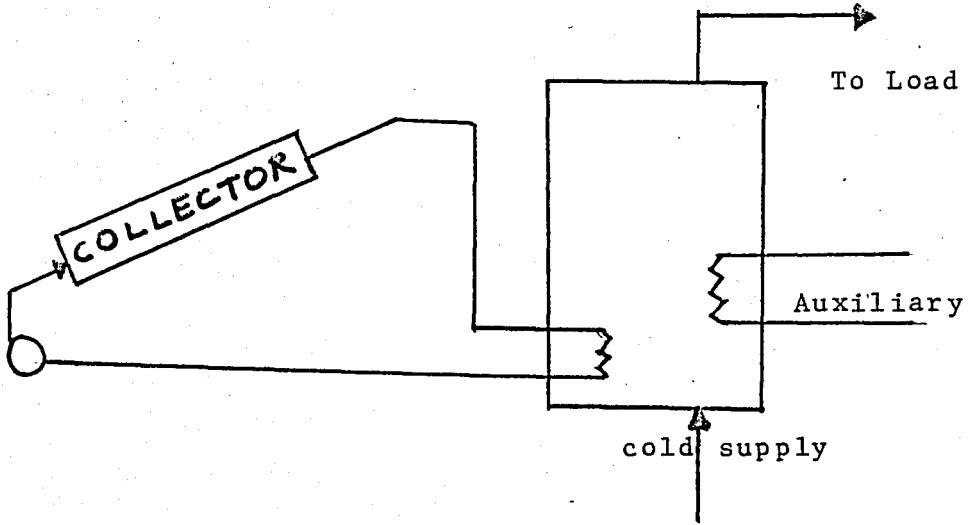

FIGURE 3.4. System with Antifreeze Loop and Internal Heat Exchanger.

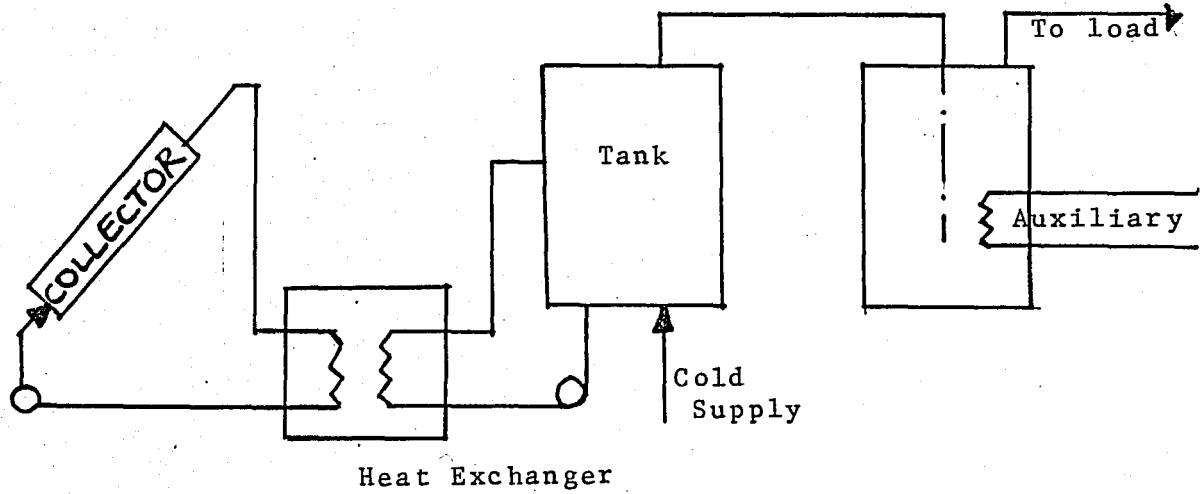

FIGURE 3.5. System With Antifreeze Loop and External Heat Exchanger. Auxiliary is shown added in the tank, in a line heater, or in a second tank; any of these auxiliary methods can be used with any of the collector-tank arrangements.

exposed to freezing temperatures are completely emptied, and the collectors must be vented. Draining systems may drain back into the tank or to a heat exchanger in the tank, or they may drain all of the system to waste.

The fifth method is to design the collector plate and piping so that it will withstand occasional freezing. Designs have been proposed using butyl rubber risers and headers that can expand if water freezes in them.

The long term performance of solar assisted water heating systems has been studied by Howarth. He has developed a simple grid analysis of system performance and has presented it in nomogram form.

The study presented here is a performance analysis of a solar assisted heat pump system for domestic hot water heating and space heating.

A detailed description and the mathematical model of the system for performance simulation is considered later on.

3.2. SOLAR SPACE HEATING

Heat for comfort in buildings can be provided from solar energy by systems that are similar in many respects

to the water heater systems described in 3.1. The two most common heat transfer fluids are water and air, and systems based on each of these are analyzed in this section. The basic components are the collector, storage unit and load (i.e., the house or building to be heated). In temperate climates, an auxiliary energy source must be provided and the design problem is in part the determination of the optimum combination of solar energy and auxiliary (i.e., conventional) energy. In combination with conventional heating equipment solar heating provides the same levels of comfort, temperature stability and reliability as conventional systems.

Since 1970 there has been a tremendous surge of interest and activity in solar heating, and a small but growing industry has developed to design, develop, manufacture, sell and install solar heating equipment and systems in the USA. As of 1977, patterns in the configurations of many air and liquid systems were emerging. These 'standard' configurations which are used with many variations, are given in some details.

Figure 3.6 is a schematic of a basic solar heating system using air as the heat transfer fluid, with a pebble bed storage unit and auxiliary furnace. The various modes of operation are achieved by appropriate damper positioning. Most air systems are arranged so

that it is not practical to combine modes by both adding energy to and removing energy from storage at the same time. The use of auxiliary energy can be combined with energy supplied to the building from collector or storage if that supply is inadequate to meet the loads. In this system configuration it is possible to by-pass the collector and storage unit when auxiliary alone is being used to provide heat. A more detailed schematic of an air system is shown in Figure 3.7. Blowers, controls, means of obtaining service hot water and more details of ducting are shown. Auxiliary energy for space heating is added to "top-off" that available from the solar energy system.

Air systems have a number of advantages compared to those using liquid heat transfer media. Problems of freezing and boiling in the collectors are eliminated and corrosion problems are reduced. The high degree of satisfaction possible in the pebble bed leads to lower collector inlet fluid temperatures. The working fluid is air, and warm air heating systems are in common use. Control equipment can be easily obtained. The disadvantages include the relatively high fluid pumping costs (if the design is not carefully made), relatively large volumes of storage and the difficulty of adding air conditioning to the systems. Air systems are also relatively difficult seal; leakage of solar heated air from

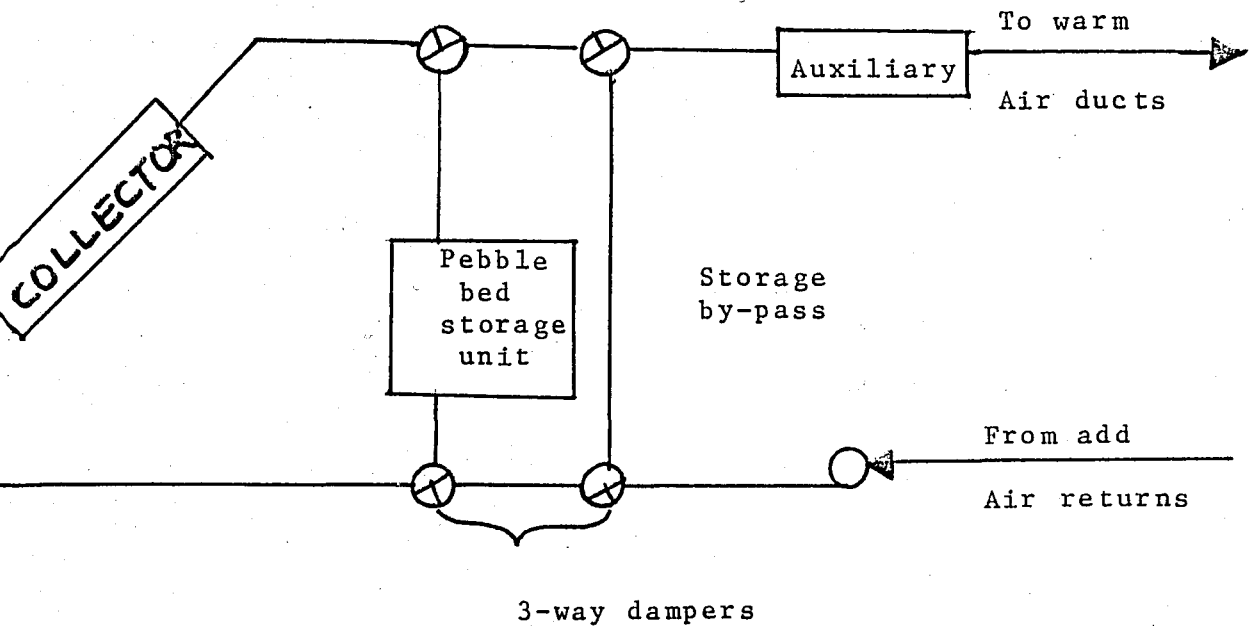

FIGURE 3.6. Schematic of Basic Hot Air System.

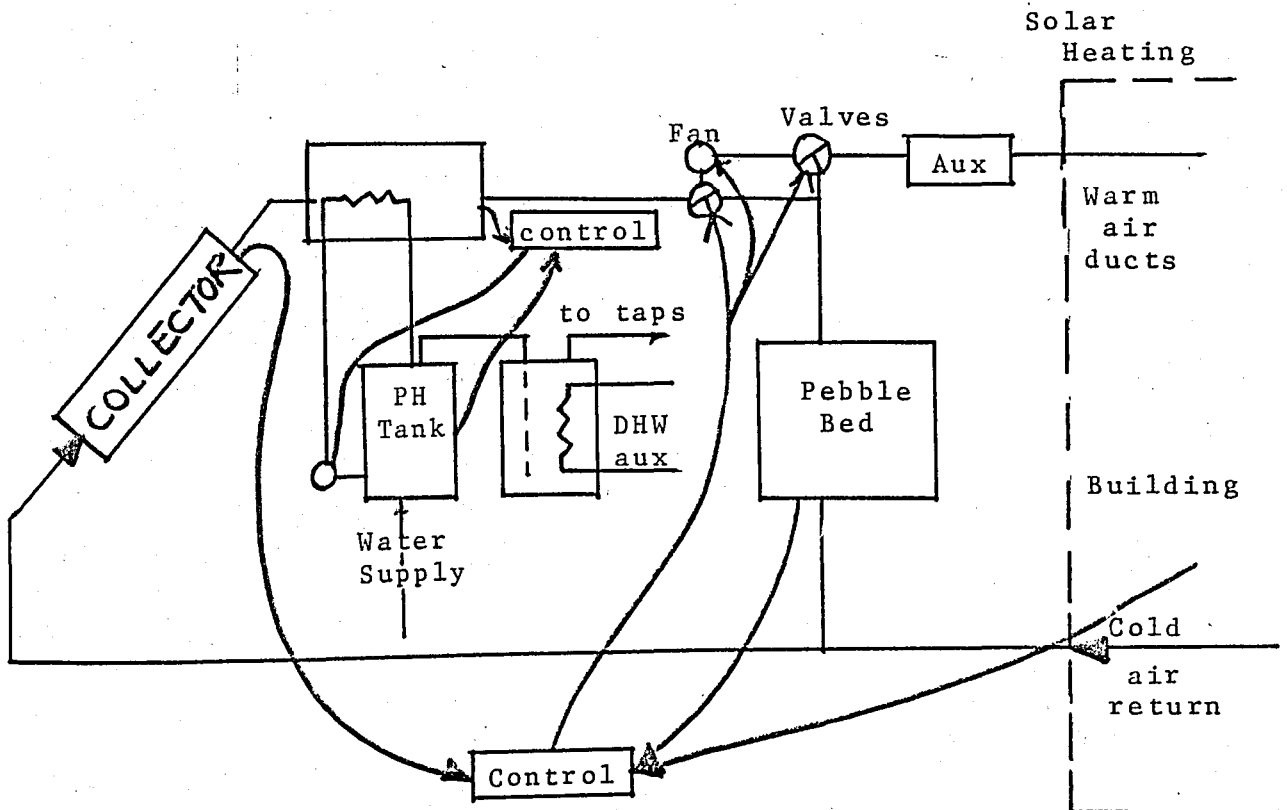

FIGURE 3.7. Detailed Schematic of a Solar Heating System Using Air as the Heat Transfer Fluid.

collectors and duct-work can represent a significant energy loss from the system. Air collectors are operated at lower fluid capacitance rates and thus with lower values of F_R than are liquid heating collectors.

More details of a liquid based system are shown in Figure 3.8. A 'collector heat exchanger' is shown between the collector and the storage tank, allowing the use of antifreeze solutions in the collector. Relief valves are shown for dumping excess energy should the collector run at excessive temperatures. A "load heat exchanger" is shown to transfer energy from the tank to the heated spaces. Means of extracting energy for service hot water are indicated. Auxiliary energy for heating is added so as to "top off" that available from the solar energy system. Advantages of liquid heating systems include high collector F_R , smaller storage volume, and relatively easy adaptation to supply of energy to absorption air conditioners.

The solar systems are considered as having four basic modes of operation, depending on the conditions that exist in the system at a particular time.

Mode 1 If solar energy is available and heat is not needed in the building energy gain from the collector is added to storage.

- Mode 2 If solar energy is available and heat is needed in the building, energy gain from the collector is used to supply the building need.
- Mode 3 If solar energy is not available heat is needed in the building, and the storage unit has stored energy in it, the stored energy is used to supply the building need.
- Mode 4 If solar energy is not available, heat is needed in the building, and the storage unit has been depleted, auxiliary energy is used to supply the building need.

There is a fifth situation that will exist in practical systems. The storage unit is fully heated, there are no loads to be met, and the collector is absorbing radiation. Under these circumstances, there is no way to use or store the collected energy and this energy must be discarded. This can happen through operation of pressure relief valves or other energy dumping mechanisms, or the collector temperature will rise until the absorbed energy is dissipated by thermal losses.

TABLE 3.1.

Typical Design Parameters for
Solar Air Heating Systems

Collector air flowrate	5 to 20 liters/m ² s
Collector slope	($\emptyset + 15^\circ$) $\pm 15^\circ$
Collector surface azimuth angle	0° $\pm 15^\circ$
Storage capacity	0.15 to 0.35 m ³ pebbles/m ²
Pebble size (graded to uniform size)	0.01 to 0.03m
Bed length, flow direction	1.25 to 2.5 m
Pressure drop: Pebble bed	55 Pa minimum
Collectors	50 to 200 Pa
Ductwork	10 Pa
Water preheat tank capacity	1.5 x conventional water heater
Max. entry velocity of air into pebble bed (at 55 Pa pressure drop in bed)	4 m/san.

TABLE 3.2

Typical Design Parameter Ranges for
Liquid Solar Heating Systems

Collector flowrate	0.010 to 0.020 kg/sm ²
Collector slope	($\emptyset \pm 15^\circ$) $\pm 15^\circ$
Collector azimuth	0° $\pm 15^\circ$
Collector heat exchanger	F_R' / F_R 0.9
Storage capacity	50 to 100 liters/m ²
Load heat exchanger	$1 < \epsilon_{L \min} / (U_A)_h < 5$
Water preheat tank capacity	1.5 x capacity of conventional heater

3.3. SOLAR ENERGY - HEAT PUMP SYSTEMS

Heat pumps use mechanical energy to transfer thermal energy from a source at a lower temperature to a sink at a higher temperature. Electrically driven heat pump heating or expensive fuels. They have two advantages: a COP (ratio of heating capacity to electrical input) greater than unity for heating, which saves on purchase of energy, and usefulness for air conditioning in the summer. Heat pumps may use air or water sources for energy, and dual source machines are under development that can use either.

A schematic of an air-to-air heat pump is shown in Figure 3.8, operating in the heating mode. The most common type in small sizes are air-to-air units. Typical operating characteristics of a residential scale heat pump are shown in Figure 3.9. As ambient air temperature (the evaporator fluid inlet temperature) increases, the COP increases, as does the capacity. As the ambient temperature drops, frost can form on the evaporator coils which adds heat transfer resistance and blocks air flow. Brief operation of the heat pump in the cooling mode removes the frost (a defrost cycle), and causes the irregularity shown in the capacity and COP curves. Figure 3.9 also shows a typical building heating requirement curve which crosses the capacity

curve at the balance point (BP). At ambient temperatures below this point a heat pump will have inadequate capacity to heat the building and the difference must be supplied by a supplemental source, which is often an electric resistance heater. At ambient temperatures above the balance point, the heat pump has excess capacity.

Solar energy systems and heat pumps are two promising means of reducing the consumption of nonrenewable energy resources, the cost of delivered energy for domestic space heating and cooling and water heating. A logical extension of each is to combine the two to further reduce the cost of delivered energy. It is widely believed that combined systems will save energy, but what is not often known is the magnitude of the possible energy savings and the value of that savings relative to the additional expense.

The analysis of combined solar-heat pump systems is not straightforward. There are many alternative ways in which these systems can interface with each other and with the load. They interact in a complex fashion.

The performance of collectors is best at low temperatures. This combination leads to consideration of series systems, in which the evaporator of the heat pump

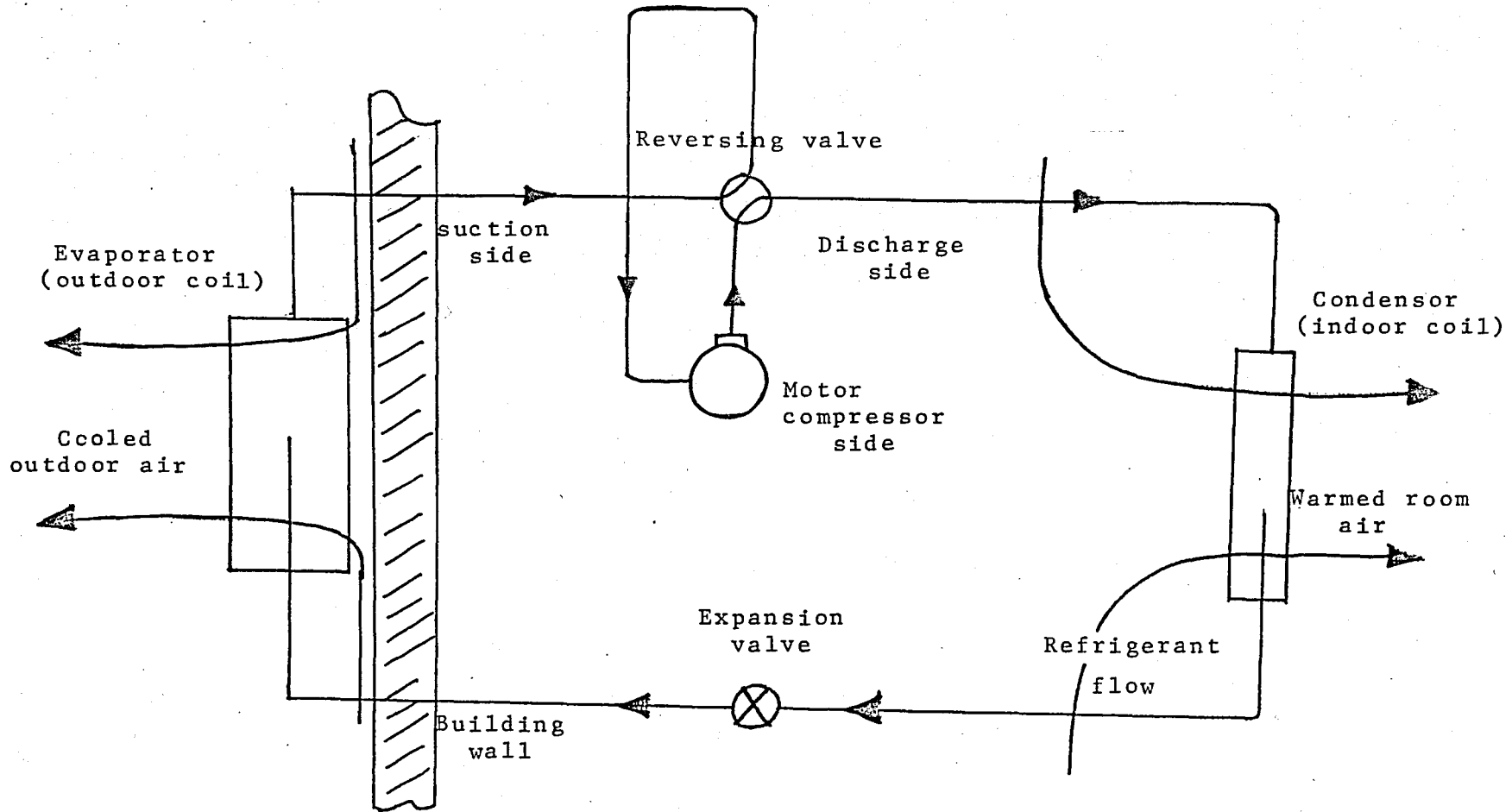

FIGURE 3.8. Schematic of a Reversible Heat Pump System Shown Operating as a Space Heater.

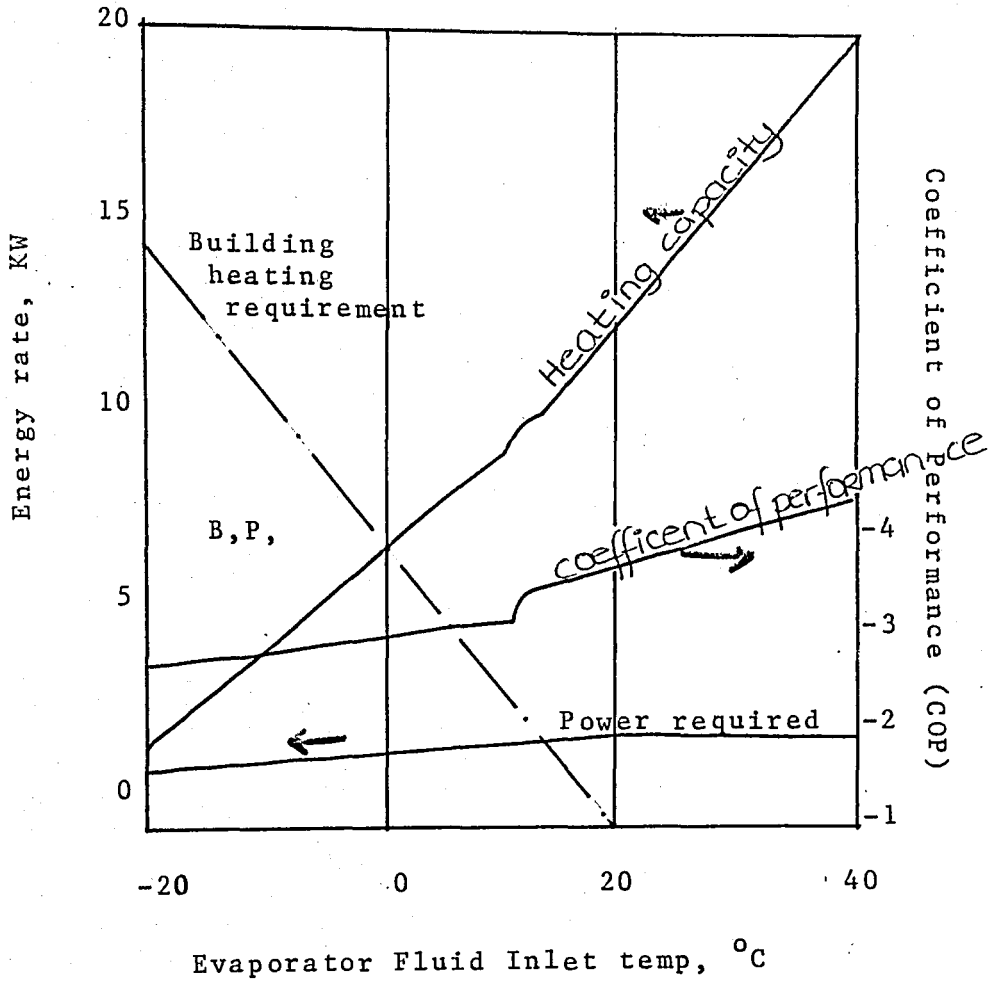

FIGURE 3.9. Operating Characteristics of a Typical Residential Scale Air-to-Air Heat Pump, as a function of ambient air temp. for delivery of energy to a building at 20°C.

is supplied with energy from the solar system. The heat pump is placed between the solar system and the load. This configuration is drawn in Figure 3.10. The evaporator is in the storage tank (or in a storage tank loop) and the condenser is placed in the house supply duct. The heat pump utilizes stored solar energy when the tank is above a set minimum temperature (usually just above the freezing point). Provision can also be made for direct solar heating by bypassing the heat pump when the storage temperature is high enough to deliver heat directly to the load. This allows the load to be met without the expenditure of heat pump work. The series system has the advantages of raising both the heat pump COP and the collector efficiency. The system shown is a liquid system, using a water-to-air heat pump as in Figure 3.10

The most straightforward combined solar-heat pump system investigated is the base solar system incorporating the base heat pump as the auxiliary energy source. This parallel system is shown schematically in Figure 3.11. The parallel system uses a liquid based solar energy system with a water-to-air load heat exchanger and an air-to-air heat pump solar energy is used to meet as much of the heating requirement as possible. The heat pump is turned on when the room temperature falls below the prescribed level. Electrical resistance

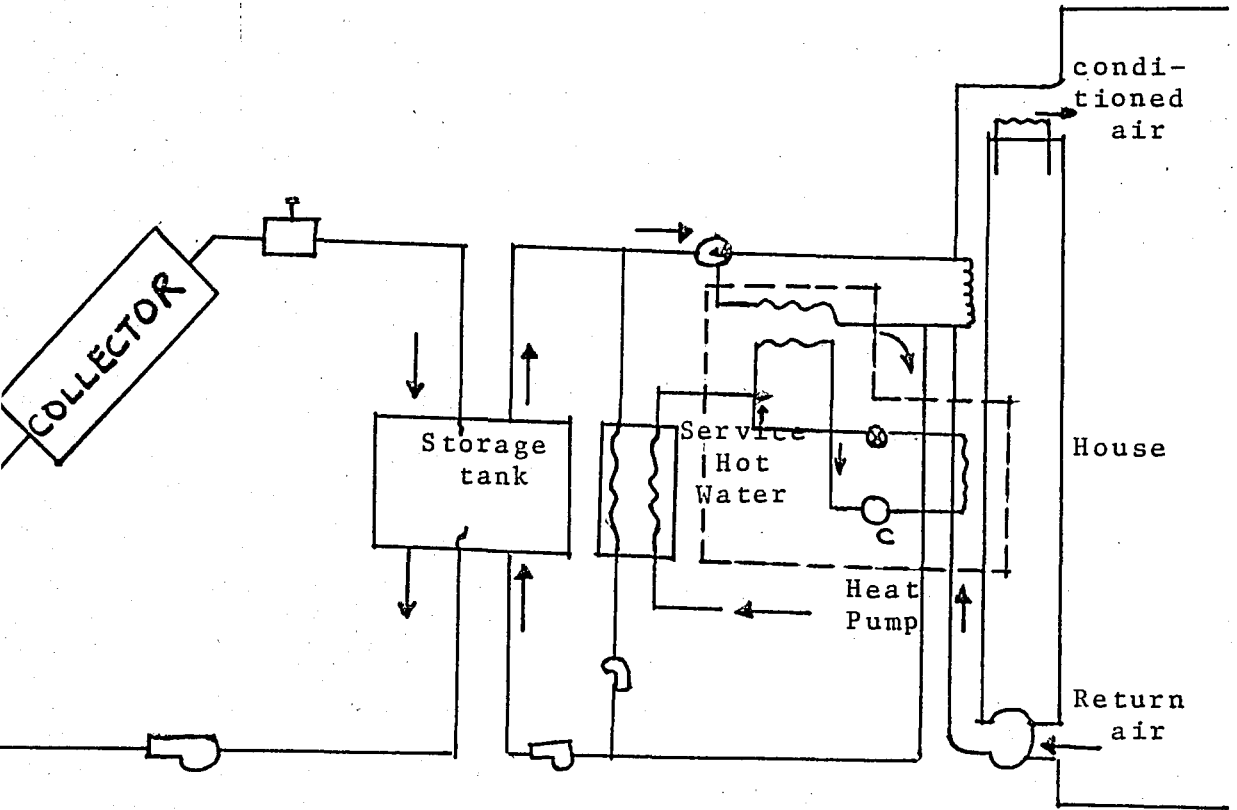

FIGURE 3.10. Schematic Diagram of the Series Solar Heat Pump System, arranged so that solar heat can be directly supplied to the House when the storage tank temperature is above room temperature. From Freeman et al (1979)

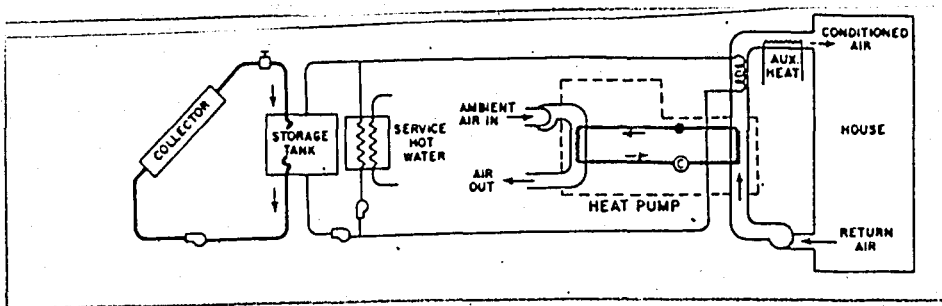

FIGURE 3.11. Schematic Diagram of the Parallel Solar Heat Pump System.

heaters are turned on when neither solar nor heat pump can maintain the set temperature. The only apparent advantage of the parallel system over other solar-heat pump is its relative simplicity. It does not benefit from the use of solar energy as a source for the heat pump, but as will be shown later, its performance compares favorably to the more complex systems.

A dual source system is shown in Figure 3.12. In the dual system, the heat pump has two evaporators, one is placed in the storage tank and the other outdoors. This allow the heat pump to use either the collected solar energy or the ambient air as the source, depending on which results in a higher COP, that is the higher of the two source temperatures. An alternative system to that shown in Figure 3.11 would be a solar system using air and an air-to-air heat pump, which could be supplied either from ambient air or solar heated air.

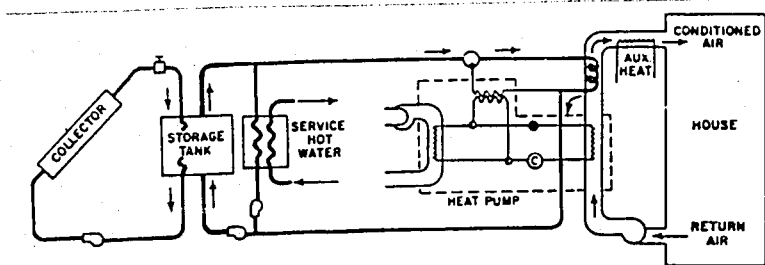

FIGURE 3.12. Schematic Diagram of the Dual Source Heat Pump System in Direct Solar Heating Mode. From Freeman et al (1979)

There are three heating modes for a dual source system. Figure 3.12 is a dual source system operating in the direct solar heating mode. Here, the storage tank is hotter than the predetermined control value and able to heat the house directly. The heat pump is off and any excess solar energy collected is being stored in the tank.

When the tank temperature is below the control value, but higher than the min. temperature and ambient temperature, fluid from the storage tank is pumped through the evaporator and used as the heat source. Depending on the magnitude of the house heating load, excess solar energy may be collected in the tank, or auxiliary energy such as electrical resistance may be supplied to the circulating air after it passes over the condensor coils.

When the tank temperature is either at its minimum temperature or less than ambient temperature, ambient air is the heat source for the evaporator, and auxiliary heat is supplied when needed. The solar system continues to operate and collect available energy to rise the tank temperature and supply domestic hot water if possible. The dual source system appears to take advantage of the best features of the parallel and series systems, but the performance is not neces-

sarily the best as it is going to be shown later.

3.4. PERFORMANCE OF COMBINED SOLAR HEAT PUMP SYSTEMS

A comparative study of the performance of combined solar heat pump systems for residential space and domestic hot water heating is summarized here. The objective of this section is to give analysis of several viable types of combined solar-heat pump systems made by T.L. Freeman, J.W. Mitchell and T.E. Audit and to give the comparison between the "conventional" solar and the "conventional" heat pump systems. The goals to determine the thermal performance of the different system configurations and to provide some insight into many of the non-intuitive reasons behind the performance results.

The combination of a heat pump and a solar energy system would appear to alleviate many of the disadvantages that each has when operating separately. During winter, the energy that could be collected by the solar system but which would be too low in temperature to be useful for direct heating can be used as a source for the heat pump. Since the solar collection storage system can supply energy at temperatures higher than the ambient outdoor air, the capacity and COP of the heat pump would increase over that for the heat pump alone,

the peak auxiliary load requirement would be reduced, and the combined heating system would seem to operate more economically. The operation of the solar system at temperatures near and below room temperature would decrease the collector losses and allow more energy to be collected. The lower collection temperature might allow the use of collectors with one or no covers, which would reduce the first cost from that of a conventional two-cover solar system. Finally, for those areas where warm temperature occur during cloudy conditions and the low capacity of the heat pump in cold weather.

In many of the studies, assumptions were made to reduce the complexity and quantity of the calculations. These often include the use of "average" or "design" weather conditions (radiation and air temperature) constant collector plate temperature, constant storage temperature, constant heat pump COP and similar simplifications.

The complexity of the thermal analysis of solar-heat pump systems makes the use of computer simulations the only method for adequately determining the system dynamics. The ASHRAE Task Group defines system simulation (pressures, temperatures, energy and fluid flow rates) at the condition where all energy and material

balances, all equations of state of working substances, and all performance characteristics of individual components are satisfied". These simulations were all performed with the general simulation program TRNSYS. This program consists of a library of subroutines which model individual pieces of hardware (e.g., collectors, tanks, heat pumps, load), and an executive routine which links these components models and solves the resulting system of equations. The simulation analysis the energy balance in the system over successive 15 minute time intervals to allow consideration of the transient effects and short-term interactions of components.

Since there is no solar-assisted heat pump yet installed in Turkey, to determine the performance is rather impossible for our climate visa. On the other hand, the empherical and analytical models of heat pump performance are both insufficient.⁽¹⁰⁾ In this study the similations made with TRNSYS of three basic combined configuration that have been explained in Section 3.3, as well as conventional solar and conventional heat pump systems, in two different climates in Wisconsion and in New Mexico is considered with data's and results and how to improve the results are discussed in order to give guidelines to further development in Turkey.

The heat pump model used in these simulations is

quasi steady-state in nature. The performance is determined by interpolating empirical performance data from manufacturer's specifications. The performance characteristics for the "standard" 3 ton unit used in most of these simulations is shown graphically in Figure 3.12. These data represent the heat pump capacity and work input in the heating and cooling modes.

Liquid source heat pumps will have a higher COP for the same source temperature due to higher heat transfer coefficients in the evaporator. However, the liquid source heat pumps assigned to operate efficiently over a broad range of source temperatures are not commercially available at present for use in solar-heat pump systems.

The solar system modeled is a conventional liquid medium system. The collector model is a simplified adaptation of the Hottel and Whillier model with a constant heat removal factor, (F_R), transmittance-absorptance product (τ_α), and loss coefficient (U_1). The values used in these simulations are given in Table 3.3, and are Duffie and Beckman's typical values.

Liquid storage tanks are modeled as being fully mixed and have loss coefficients of $3.6 \text{ W/m}^2\text{-C}$. storage losses are assumed not to contribute to the heating

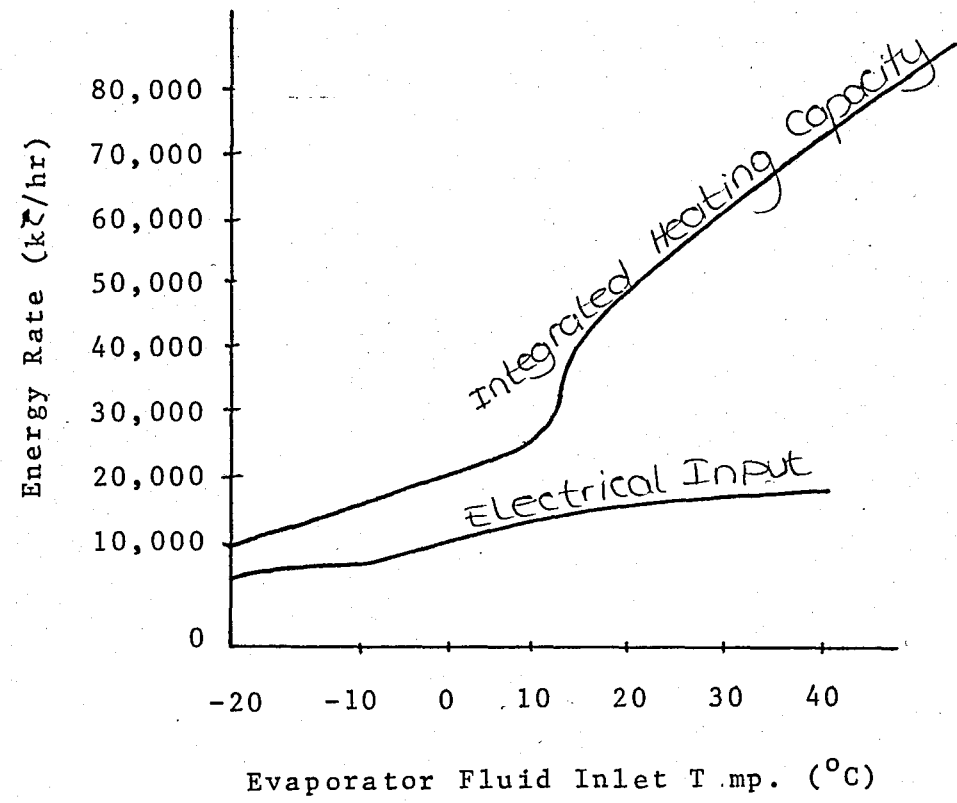
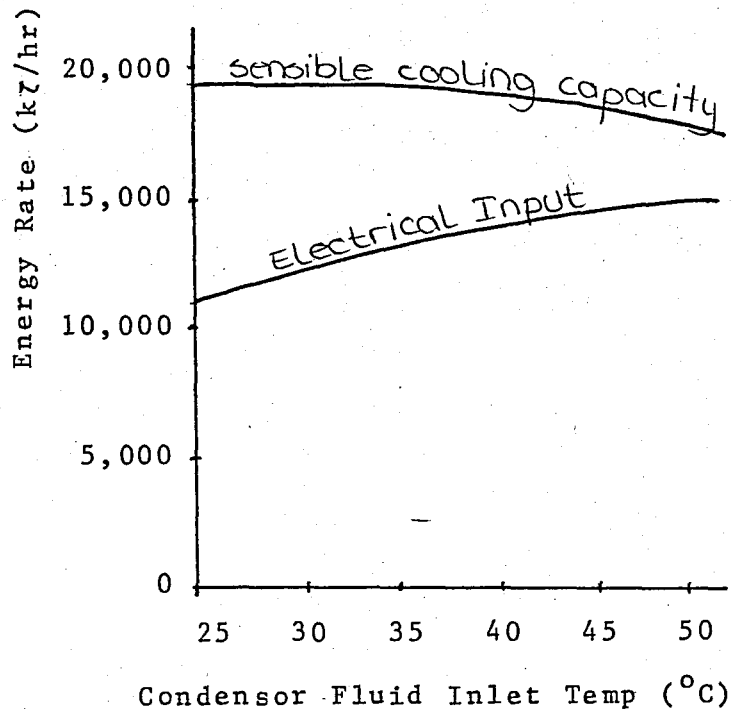

FIGURE 3.13. Operating Characteristics for a Typical 3 Ton Air-Air Heat Pump.
 (a) Heating Performance. (b) Cooling Performance.

TABLE 3.3

Collector Parameters

Liquid Collector Type	F_R	U_L (W/m ² °C)	(τ_α)
Zero-glazed	0.90	30	0.90
Single-glazed	0.90	8.33	0.76
Double-glazed	0.90	5.56	0.69

requirements. Main storage tanks are sized in accordance with recommendations for conventional solar systems (0.075 m³/m²).

The building used in each of the simulations is the same single-family residence of approximately 120 m² floor area which is well insulated with an overall loss coefficient of 15,000 kJ/day-C. Internal generation and solar heat gains are included in the load calculation. The service hot water load is assumed to be 21.5 kg/hr of 60°C water drawn uniformly twice every day resulting in 21.37 GJ.

The important quantities for the evaluation of the systems are the seasonal energy flows. For space and service hot water heating, these are the sum of the house space and water heating loads: Q_{LOAD} , the heat collected by solar energy system: Q_{SOLAR} , the heat extracted by the heat pump from the ambient air: Q_{AIR} , the

electricity required by the heat pump compressor and fans: W_{HP} , and the auxiliary energy required to meet the hot water and space heating loads: E_{AUX} . E_{AUX} is the delivered energy and is less than the purchased fuel energy due to furnace and water heater inefficiencies. The system energy balance in equation form is:

$$Q_{SOLAR} + Q_{AIR} + W_{HP} + E_{AUX} = Q_{LOAD} = \begin{matrix} \text{(Total annual} \\ \text{house space} \\ \text{and water} \\ \text{heating re-} \\ \text{quirements)} \end{matrix}$$

The first two terms are "free" energy, while the second two terms represent "purchased" energy. A measure of the thermal performance of combined solar heat pump systems is the fraction (F) of the total load that is met by non purchased energy, defined as:

$$F = \frac{(Q_{AIR} + Q_{SOLAR})}{Q_{LOAD}} = \text{Index of system performance}$$

$$F = 1 - \frac{(W_{HP} + E_{AUX})}{Q_{LOAD}}$$

The auxiliary energy may be supplied by gas, oil, electricity or a combination, while the heat pump work is almost always electricity. The thermal performance fraction, does not distinguish between the different kinds and prices of fuels but only reflects energy re-

quirements.

The fraction, F , is shown in Figure 3.14.a for Madison as a function of collector area for the conventional single cover solar system. For a house with neither a solar energy system nor a heat pump, F equals zero. For a house with only a heat pump, the fraction of the heating requirement supplied by non purchased energy Q_{AIR} is divided by the total heating requirement and equals 36 percent. Since the heat pump does not contribute to the domestic hot water system, the value of F depends on the COP and the relative sizes of the space and water heating loads and is usually between 0.2 and 0.4. For a house with a conventional solar system, F depends on collector area. As collector area increases, F increases from zero asymptotically towards unity. The collector size necessary for the solar energy system to consume less auxiliary energy than the conventional heat pump system is between 15 and 20 m². A two-cover conventional solar system requires less auxiliary than a single-cover system.

The simulations results for the performance of the parallel, dual source, series, conventional solar and conventional heat pump system using both 1- and 2-cover collectors are shown in Figure 3.14.b. The curves for the conventional solar and heat pump systems have been

transposed from Figure 3.14.a. At zero collector area, the parallel system performs like the conventional heat pump system; they are in fact the same system. At small collector areas, the heating supplied by solar and by heat pump contribute to the total with a minimum of interaction. The heat pump COP is not degraded significantly by the solar contribution. As collector area increases, the parallel system F asymptotically approaches unity in the same manner as for the conventional solar system, but is significantly higher. With increasing area, the solar system meets a larger fraction of the load, but the heat pump operates under less favorable conditions and consequently at a reduced COP which approaches unity. As a result, the combined system performs more and more like the conventional solar system at larger collector areas. The parallel system with a 2-cover collector is better than the single-cover system, but two covers do not increase performance for the parallel system as much as for conventional solar system.

The series system performance is better than that of the conventional solar system for all collector areas, but the difference is small. The difference reaches its maximum at a collector area of about 30 m^2 . Below that, the small collector area "starves" the heat pump by not being able to meet the energy demand. The tank temperature remains very near the minimum usable temperature,

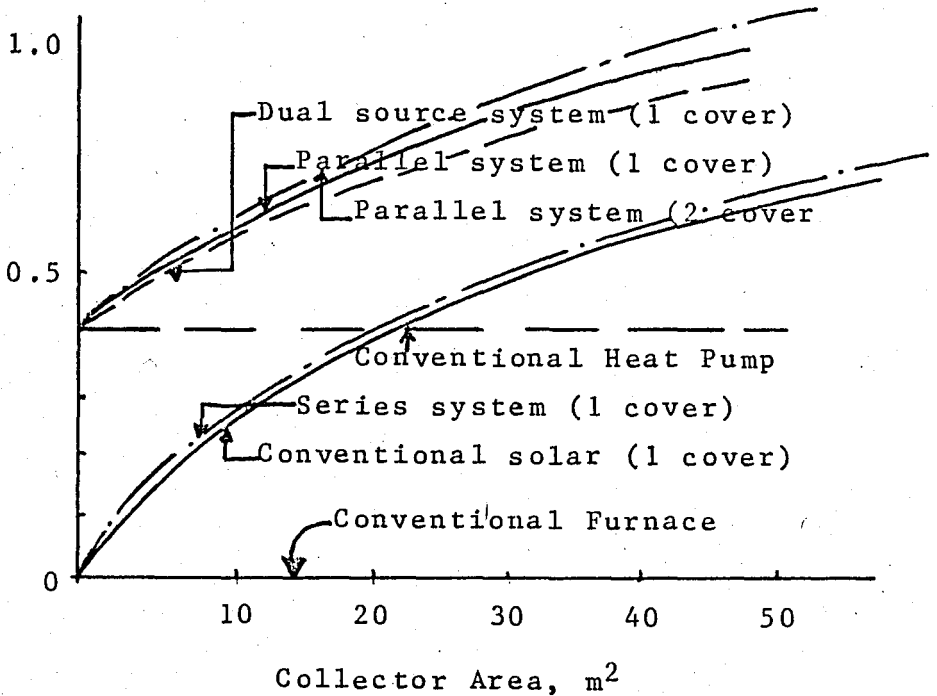
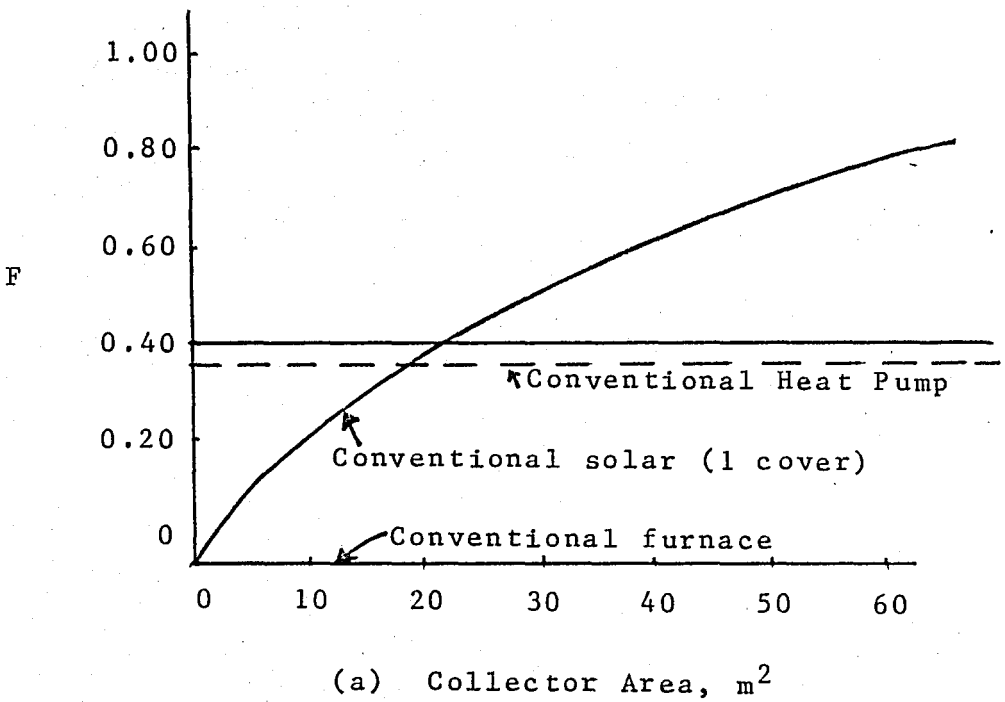

FIGURE 3.14. Fraction of Annual Load Met by Free Energy as a function of Collector Area in Madison for (a) conventional heat pump and solar systems; (b) parallel, series and dual source systems.

and when the heat pump operates, it does so at nearly its lowest COP. As collector area increases above 30 m², the difference between the series and conventional solar system performance remains nearly constant.

The performance of the dual source system is relatively poor. Like the parallel system, at zero collector area the dual source system reduces to the conventional heat pump system. As collector area increases, the performance increases but is inferior to that of the parallel system.

3.4.1. Discussion

The simulation results indicate that the seasonal collector performance for the parallel and conventional solar systems of the same collector area are equal and equal for the series and dual source systems. The improved collection efficiency is the direct result of the solar source heat pump capability, which maintains lower average storage temperatures and hence lower collector temperatures in both the series and dual source systems.

The solar source heat pump capability improves the collector performance for small collector areas in the middle of the heating season. For larger collector areas and in the spring, fall and summer when the ratio

of available solar energy to the load is larger, the improvement in collection efficiency decreases significantly.

Improved collector performance and higher Q_{SOLAR} is not only the direct consequence of adding the solar source capability, but is the only benefit to system performance during the heating season. The improved collector performance is achieved at the expense of heat pump electrical power input which usually displaces a cheaper fuel. The annual energy balance requires that the sum of all energy supplied equal the load, or

$$Q_{\text{SOLAR}} + Q_{\text{AIR}} + W_{\text{HP}} + E_{\text{UAX}} + Q_{\text{LOAD}}$$

The relative contributions from each of these four heat sources is illustrated in the bar graphs of Figure 3.15 for the parallel, dual source, and series solar-heat pump systems, and for the conventional solar and heat pump systems.

The trends are similar to these for other system sizes and locations. The combined height of the Q_{SOLAR} and Q_{AIR} bars in Figure 3.15 represent the percentage of the total heating requirement supplied by free energy and is therefore equivalent to F . The systems are ranked

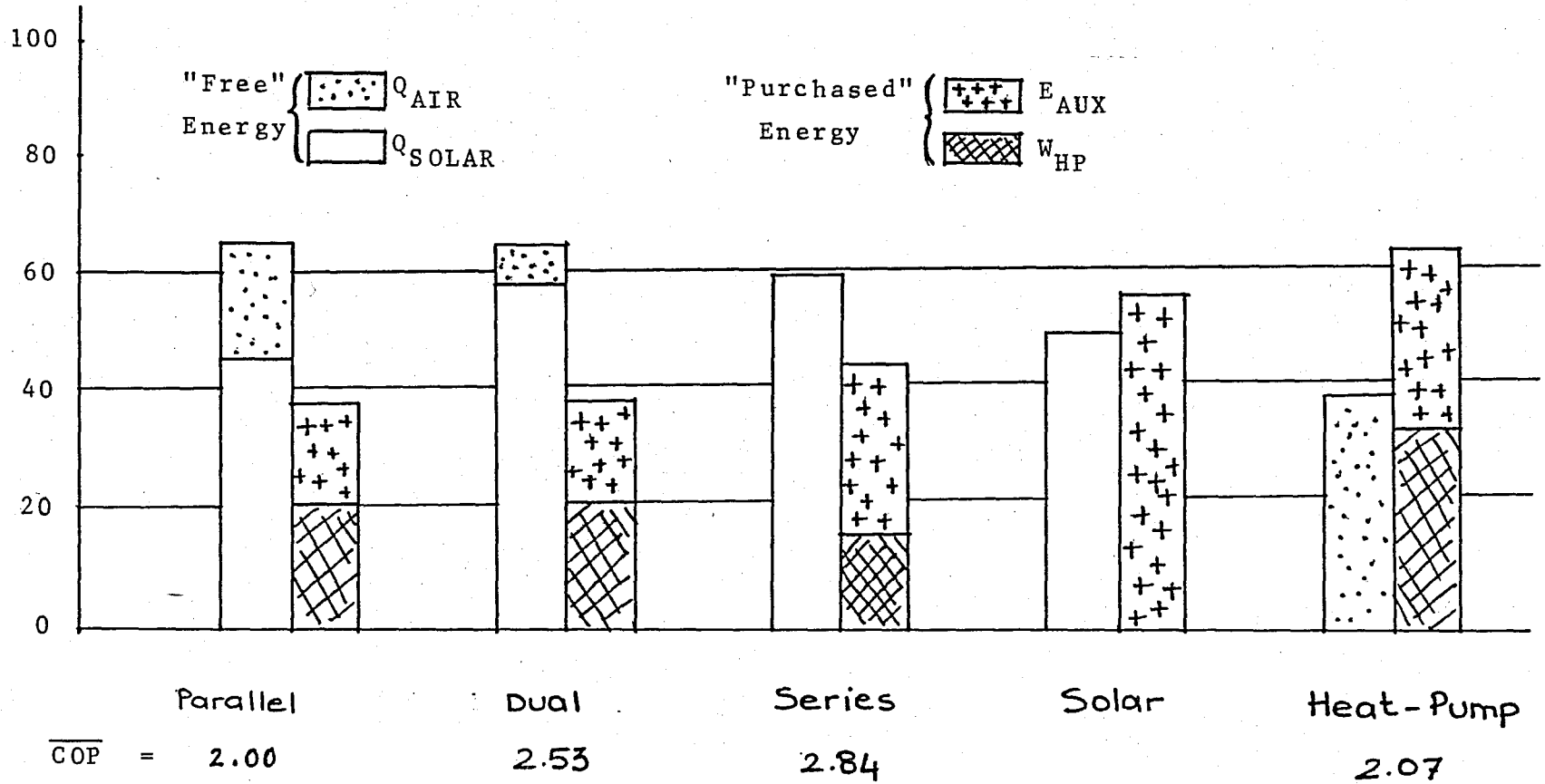

FIGURE 3.15. Heating Contributions from all Possible Sources for Combined Conventional Systems.

from left to right in order of decreasing savings of purchase energy; that is decreasing F .

As can easily be seen from Figure 3.15, adding the solar source capability to the conventional solar system to create the series system increases Q_{SOLAR} modestly by ΔQ_{SOLAR} . The balance of the load must be supplied with purchased energy (W_{HP} and E_{AUX}) since Q_{AIR} is 0 for both systems. The net increase in F is just $\Delta Q_{\text{SOLAR}}/Q_{\text{LOAD}}$.

Adding the heat pump to the solar system in parallel reduces Q_{AUX} by an amount equal to Q_{AIR} . Adding the solar source capability to the parallel system to create the dual source system again increases Q_{SOLAR} by about the same ΔQ_{SOLAR} but decreases the amount of energy extracted from ambient air by nearly the same amount. The net effect is, the value of F for the dual source system is very nearly the same as for the parallel system.

The heat pump seasonal $\overline{\text{COP}}$ (ratio of rejected heat to work input) varies between the systems. The use of solar source for the heat pump raises the seasonal $\overline{\text{COP}}$ over that of the conventional heat pump and parallel systems. As illustrated in Figure 3.15, the annual heat pump heating COPs for the parallel, dual source, series and conventional heat pump systems are 2.0, 2.5, 2.8 and 2.1 respectively. The $\overline{\text{COP}}$ for the series and dual source

heat pumps are substantially higher since they utilize the solar heated storage tank as a source. The series heat pump $\overline{\text{COP}}$ is higher than that of the dual source system even though the latter has the apparent advantage of utilizing the more favorable source - either ambient air or storage. This is because the series heat pump operates only down to a source temperature of 5°C , while the dual source heat pump often utilizes much colder ambient air as a source when the tank reaches the freezing point. As a result the dual source heat pump supplies more heat to the house than the series heat pump but does so at a lower COP.

The parallel system has better overall performance than the series and dual source systems with both a lower collector efficiency and a lower heat pump COP. The reason is that in the dual source and series systems, heat pump work must be expended, to utilize the same energy that is collected and supplied directly to the house without heat pump work in the conventional solar and parallel systems. Usable solar energy in the series and dual systems must essentially be delivered twice: first by the solar system and again by the heat pump. The temperature of storage in the series and dual source systems is high enough to supply heat directly during the heating season, whereas the higher storage temperatures in the conventional solar and parallel systems

frequently permit direct heating.

Heat pumped through the heat pump in any configuration costs more in energy expenditure than direct heating by solar. Under the most favorable conditions, the heat pump COP is on the order of 3-5, while the solar system COP is much higher since pump or fan work is the only purchased energy input. Direct heating by the solar system as much as possible is preferable for reducing the energy requirements.

The results of the simulations explained above show that with the same collector the parallel system is substantially better than the series system and slightly better than the dual source system in all collector sizes, in that it delivers a greater fraction of the loads from "Free" sources. This arises because the heat pumps in the series and dual source systems must operate to deliver all solar energy stored below 20C. The extra electrical energy required to deliver the energy more than compensates for the combined advantages of higher collector efficiency and higher heat pump COP.

3.4.1.1. Effects of Increases Storage Size

The larger storage sizes may benefit the systems incorporating solar source heat pumps more than

conventional solar or parallel systems. Tank temperatures are near the lower limit in the series and dual source systems. Larger storage may reduce the time that tank temperatures is at these lower levels with a resultant improvement in the system performance.

3.4.1.1. Effect of Improved Heat Pump Performance

The characteristics of Figure 3.13 were successively improved by reducing the amount of electrical work input (W) at all source temperatures to result in increase of COP over the base COP by factors of 1.24, 1.50, 1.75 and 2.00. The values of heat rejected (QR) were left unchanged, while the values of heat absorbed (QA) were increased to compensate for the reduction in electrical work input. Thus for all four of these improved heat pumps, $QA + W = QR$ at all source temperatures. The domestic hot water subsystem was removed from each of the systems and the parallel, dual source, and series systems with 30 m² of collector and the conventional heat pump were simulated with the better performing heat pumps.

Figure 3.17 shows the resultant effects of the improved characteristics for each of these systems. The conventional heat pump system undergoes a significant increase in the fraction of energy supplied by free

energy as COP is increased since more energy is absorbed from the air and less must be supplied to the compressor. The parallel system undergoes a smaller improvement since the heat pump contribution to the total load is less than in the conventional heat pump system. Dual source system performance follows that of the parallel system very closely. The series system performance, however is hardly improved at all. The improvement in COP for air source operation, not solar source operation, improves performance. A higher COP heat pump reduces the electrical work requirement at the expense of a corresponding increase in auxiliary.

3.4.1.3. Effects of Climate

Several factors affect the performance of the combined systems under different meteorological conditions. The performance of these systems is sensitive to the degree of correlation between ambient temperature and solar radiation. In warmer climates, the domestic hot water load becomes a larger portion of the total load and since the heat pump cannot contribute directly to domestic water heating in any of the systems investigated, the relative ranking of systems might be affected. Finally, in warmer climates, the cooling season performance may have a strong bearing on which is the most cost effective system.

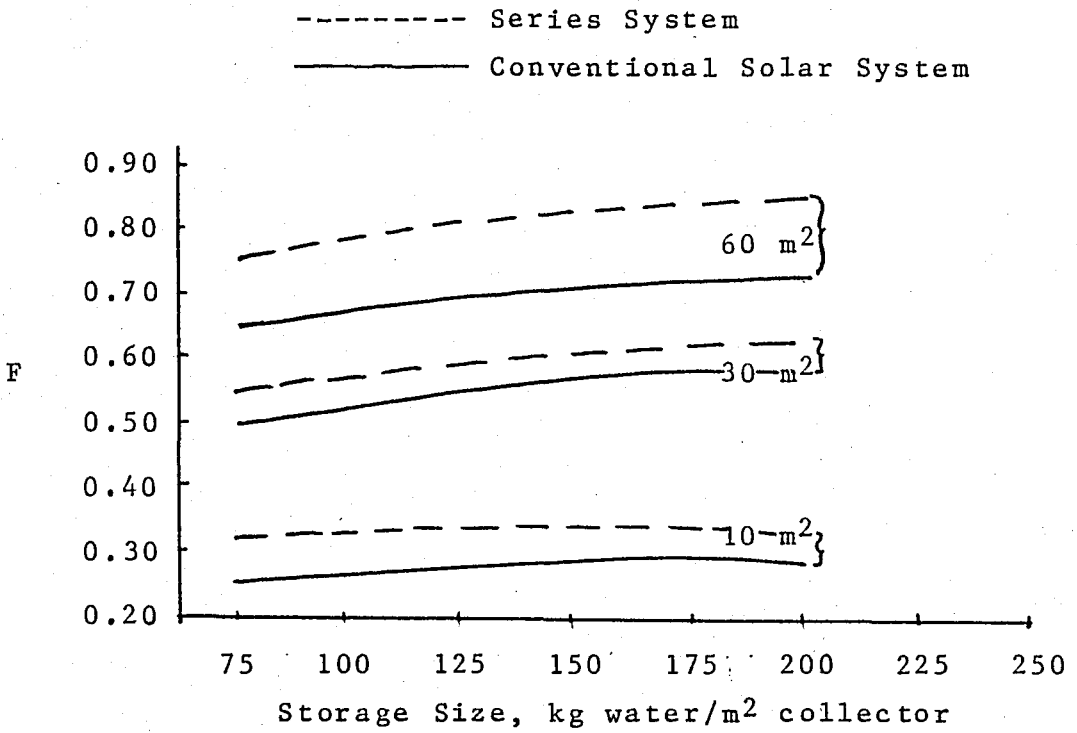

FIGURE 3.16. Effect of Storage Size on Series and Conventional Solar System Performance

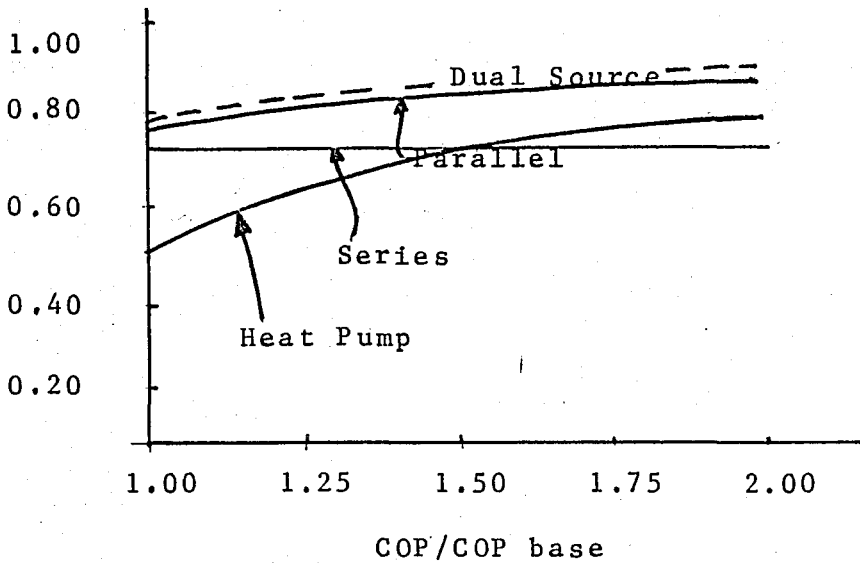

FIGURE 3.17. Effect of Heat Pump Characteristics on Combined Systems Performance.

3.5. CONCLUSIONS AND RECOMMENDATIONS

The following trends can be noted in the results of the simulations done at the two destinations mentioned above; for the base solar heating, base heat pump and 3-types of solar assisted heat pump systems.

First, higher collector efficiencies can be expected from solar-assisted heat pump systems since the collectors operate at substantially lower temperatures than in a conventional solar system. For the system to be competitive with an oil fired heating system, a solar tank control temperature of 15°C has been suggested.

Secondly, as the collector area is the only limiting factor in the amount of solar energy that can be provided to a load heated by a conventional solar system, it is also one of the most significant design variables of a solar-assisted heat pump system.

Thirdly, the seasonal $\overline{\text{COPs}}$ shows little or no increase with storage size in all systems explained above.

In spite of the advantage of a solar-assisted heat pump system, they are capital intensive, as are solar energy systems. On the other hand, since heat pump needs electrical energy, even though it saves energy compared

with conventional systems, this electrical energy must be utilized from natural sources, so that operation cost of the system is lower. Unfortunately in our country, both electric energy deficit and high cost of electric energy are unfavorable facts against heat pumps. But since the heat pump has a higher COP, when the temperature interval in which it operates is small, the climatic zone in our country provide a favorable environment for its application provided that the electrical energy deficit is overcome by lower cost electrical energy utilization.

The best solution for the future is a hybrid system as is the objective of this study which integrates the cost effectiveness of the heat pump with improved performance levels around 200% of solar systems.

I hope that this study will provide some guidelines to people who are going to the field of solar assisted heat pump systems.

REFERENCES

1. Tanoğlu Ali, 'Enerji Kaynakları', 4 th edition, İstanbul University Press No: 124, İstanbul 1971.
2. Camatini, E., Kester, T., 'Heat Pumps and Their Contribution to Energy Conservation', NATO Advanced Study Enstitute Series, Leyden, 1976.
3. Yoğurtçuoğlu S.A., 'Simulation of a Solar-Assisted Heat Pump System', M.S. Thesis, Mech. Eng. Dept., Manchester University, Manchester, 1977.
4. Heating, Piping and Air Conditioning, Vol. 47, pp.23-27, February, 1975.
5. Presley, H.M. and Turner, W.C., AIEE Proceedings, 1978, Spring Annual Conference, pp.37-43, 1978.
6. Gordon, H.T., 'A Hybrid Solar-Assisted Heat Pump System for Residential Applications', Sharing the Sun, Vol.3. Solar Heating and coding of Buildings, 1976, Canada.
7. Van Amerongen, C., 'Heat Pump', How Things Work, Vol.1, pp.228-230, Granada Publishing Limited, England. 1972.
8. Von Cube, H.Ludwig, Steimle, Fritz,, Heat Pump Technology, Butter Worth & co(Publishers) Ltd, England, 1981.
9. Duffie, John A., Beckman, William A., Solar Engineerin of Thermal Processes, John Wiley & Sons, Inc., Canada, 1980.
10. Freeman, T.L., Mitchell J.W. and Audit T.E., 'Performance of Combined Solar-Heat Pump Systems', Solar Energy, Vol.22, pp.125-135, Pergamon Press Ltd, England, 1980.