

HIGH FREQUENCY RFID MODULE DESIGN

by

Özgür Özen

B.S., Electrical and Electronics Engineering, Boğaziçi University, 2012

Submitted to the Institute for Graduate Studies in
Science and Engineering in partial fulfillment of
the requirements for the degree of
Master of Science

Graduate Program in Electrical and Electronics Engineering
Boğaziçi University

2015

ACKNOWLEDGEMENTS

I would like to thank my supervisor Assist. Prof. Heba Yüksel for her continuous support and guidance. I am deeply grateful for her excessive tolerance and assistance.

I would like to thank to Tübitak for providing me funds during my M.S education.

I thank my manager Tevfik Örkün for his encouragement and tolerance during my thesis. I thank Arçelik A.Ş. TV Design and Application Department for supports.

Last but not least, I would like to thank my family for their love and encouragement.

ABSTRACT

HIGH FREQUENCY RFID MODULE DESIGN

Radio frequency identification (RFID) is a rapidly growing technology area and it has numerous advantages such as none-LOS and contact-less operation, multiple tag identification, long read range and tag re-programmability. During last decade, smart phones began to spread tremendously and this fact makes RFID very popular for consumer applications. With new evolutions in chip technology, RFID has the potential to lead many industries. The aim of this thesis is to provide a design process for a 13.56 MHz RFID reader and antenna that used in a special TV application. The final design is placed in a TV unit and it provides that only specific users that equipped with particular passive cards can access particular menus and applications on TV. Therefore, users can control their personal menus and information in electronic device in a secure way. In this thesis, the design methodology of the reader and the antenna is presented and at the end of the work, the final reader design achieves communication up to about 5 cm with passive cards which is desired operation distance for similar near field communication applications. Also, return loss is obtained as 27 dB at operation frequency of 13.56 MHz.

ÖZET

YÜKSEK FREKANS RFID MODÜL TASARIMI

Radyo Frekans ile Tanımlama (RFID) hızlı şekilde gelişen bir teknoloji alanıdır ve bu teknolojinin görüş hattı ve temas gerektirmemesi, çok sayıda kart tanımlanabilme imkanı, yüksek okuma mesafesi ve tekrar programlanabilmesi gibi çok sayıda avantajı vardır. Son on yılda, akıllı telefonların çok hızlı bir şekilde yaygınlaşmasıyla birlikte RFID tüketici uygulamaları da oldukça popüler olmuştur. Bu tezde, özel bir TV uygulamasında çalışacak 13.56 MHz frekanslı RFID okuyucu ve anten tasarımı amaçlanmıştır. Tasarlananan devre TV ünitesi içerisinde yer almakta ve sadece uygun pasif karta sahip kullanıcıların TV'deki belirli menü ve uygulamalara erişimine izin vermektedir. Böylece, kullanıcılar elektronik cihazlarda kendi özel bilgilerine ve menülerine güvenli bir şekilde erişebilecektir. Bu tezde, okuyucu ve anten tasarım metodları belirtilmiş ve tasarlanan devre uygun pasif kartlarla, benzer yakın mesafe haberleşme uygulamalarında da arzu edilen mesafe olan yaklaşık 5 cm mesafeden haberleşmeyi başarmıştır. Ayrıca, tasarlanan devrede 13.56 Mhz frekansında 27 dB dönüş kaybı elde edilmiştir.

TABLE OF CONTENTS

ACKNOWLEDGEMENTS	iii
ABSTRACT	iv
ÖZET	v
LIST OF FIGURES	viii
LIST OF TABLES	x
LIST OF SYMBOLS	xi
LIST OF ACRONYMS/ABBREVIATIONS	xii
1. INTRODUCTION	1
1.1. History of RFID	1
1.2. RFID Application Areas	1
1.3. RFID Principles	3
1.3.1. Theory of Operation	3
1.3.2. Tags	4
1.3.3. Readers	6
1.3.4. Databases and Application Software	6
1.3.5. Antenna	7
1.3.6. Operating Frequencies	7
1.4. Coupling Types	9
1.4.1. RFID Capacitive Coupling	10
1.4.2. RFID Inductive Coupling	10
1.4.3. RFID Backscatter Coupling	12
1.5. NFC	12
1.5.1. NFC Technology Device Types	13
1.5.2. NFC RF Signal Coding	14
1.5.3. Manchester Coding	14
1.5.4. Modified Miller Coding	15
1.6. ISO Communication Standards	16
1.7. EMC Regulations for RFID Applications	16
2. ANTENNA DESIGN CRITERIAS	18

2.1. Desired Application	18
2.2. Design Steps	19
2.3. Simulation Tool	19
2.4. Loop Antenna Basics	20
2.4.1. Antenna Inductance	21
2.4.2. Magnetic Field Strength of the Antenna Coil	23
2.4.3. Induced Voltage	24
2.4.4. Number of Turn	25
2.4.5. Antenna Symmetry	25
2.4.6. Antenna Size	27
2.5. System Performance	27
2.6. Design Considerations	27
2.6.1. Proximity of Metal	27
2.6.2. Quality Factor	28
3. READER AND ANTENNA DESIGN	30
3.1. Main IC	30
3.2. Antenna Design	32
3.2.1. Quality Factor	37
3.3. EMC Filter Part Design	38
3.4. Matching Part Design	38
3.5. Receiver Part Design	41
3.6. Layout Considerations	41
3.7. Simulation Results	42
3.7.1. Tuning and Optimization	43
3.8. Measurements and Experimental Results	44
3.9. Optimized Results	47
3.10. Read Range Measurements	48
3.11. Smart Card Effect	50
4. CONCLUSION	52
REFERENCES	53

LIST OF FIGURES

Figure 1.1.	Sample RFID system.	3
Figure 1.2.	Inductive coupled RFID system.	11
Figure 1.3.	Manchester coding used for NFC data transfer.	15
Figure 1.4.	Modified Miller coding.	15
Figure 2.1.	Modelling rectangular planar antenna.	21
Figure 2.2.	The representing graph of the magnetic field strength of the N turn square loop.	23
Figure 2.3.	Ground current compensation.	26
Figure 2.4.	4 turn symmetric antenna example.	26
Figure 3.1.	Sample application diagram of PN531.	31
Figure 3.2.	Series equivalent model for antenna.	33
Figure 3.3.	Parallel equivalent model for antenna.	33
Figure 3.4.	Reader antenna model.	35
Figure 3.5.	ADS input parameter simulation results.	35
Figure 3.6.	Antenna series equivalent resistance calculation.	36

Figure 3.7.	Eight possible configurations of the two-component matching networks.	39
Figure 3.8.	Definition of transformation impedance (Z_{tr}).	40
Figure 3.9.	ADS simulation results of the design with all of calculated components.	42
Figure 3.10.	Simulation results using optimized values of matching components.	43
Figure 3.11.	Antenna input impedance measurements (1-5 MHz).	44
Figure 3.12.	Built protoype.	45
Figure 3.13.	Measurement setup.	46
Figure 3.14.	Experimental return loss measurements of the design.	46
Figure 3.15.	Experimental return loss measurements with optimized design.	47
Figure 3.16.	Smith Chart measurements with optimized design.	47
Figure 3.17.	Measurement setup for range measurement.	48
Figure 3.18.	Maximum read range measurements of the optimized reader design.	49
Figure 3.19.	Measurement setup for measuring smart card effect.	51
Figure 3.20.	Return loss measurements using the detuned values of matching components.	51

LIST OF TABLES

Table 1.1.	Comparison of passive, semi-passive, and active tags.	5
Table 1.2.	Common operation frequencies for RFID applications.	8
Table 1.3.	NFC coding types.	14
Table 1.4.	Allowed field strength of common RFID operating frequencies. . .	17
Table 3.1.	Physical dimensions of the reader antenna.	34
Table 3.2.	Properties of the dielectric material.	35
Table 3.3.	Bill of Materials of the design using calculated components.	45
Table 3.4.	Bill of Materials of the optimized design.	50

LIST OF SYMBOLS

B_0	Magnetic field strength
d	Distance
E	Electric field
f	Frequency
g	gap between tracks
N_a	Number of turns
Q	Quality factor
S	Area
S_{11}	Return loss
t	Track thickness
w	Track width
Z	Impedance of a medium
α	Relative angle of the signal
ϵ	Permittivity of a material
λ	Wavelength
μ	Permeability of a material
σ	Conductivity of a material

LIST OF ACRONYMS/ABBREVIATIONS

ASK	Alternating Current
ASK	Amplitude Shift Key
DC	Direct Current
EMC	Electromagnetic Compatibility
EPC	Electronic Product Code
FDTD	Finite Difference Time Domain
FEM	Finite Element Method
HF	High Frequency
ISO	International Organization for Standardization
LF	Low Frequency
LOS	Line-of-Sight
MoM	Method of Moment
NFC	Near Field Communication
PCD	Proximity Coupling Devices
PSK	Phase Shift Key
RFID	Radio Frequency Identification
SHF	Super High Frequency
SRD	Short Range Devices
UHF	Ultra High Frequency
VSWR	Voltage Standing Wave Ratio

1. INTRODUCTION

RFID technology uses radio waves carrying information to identify objects via space coupling. Automatic identification technology provides information about people, animals, goods and products. In recent years, automatic identification has become very popular in many industries such as purchasing, distribution logistics, and manufacturing. These days, RFID is considered to be one of the major technology for item tracking and inventory management [1].

1.1. History of RFID

History of RFID starts with the invention of the Radar technology. Radar systems transmit a high power signal, and identified objects passively reflect a small amount of the RF energy back. The first built radars could detect the presence of objects, but it could only give only the size information [1]. Then, further developments were achieved for low cost commercial applications such as maritime transports, traffic information systems, and other special applications [2]. RFIDs have grown rapidly in the middle of 1990s leading to strong standardization activities in the 1990s. In 2002, a new standard for near field communication (NFC) was defined. NFC allows both, the communication between a mobile phone and an RFID card, as well as between NFC devices. The application area grew rapidly, because the mobile phone allows users to be an active partner in communication. Currently, a number of standards exist that define the frequencies, communication methods and now RFID is evolving as a major technology in the areas of access control, maritime and transport [3].

1.2. RFID Application Areas

Currently, RFID is used in various application areas such as electronic toll collection, supply chain management, retail item management, access control, tracking, and vehicle security. Moreover, individual applications such as quick payments, automatic personalization of devices and services are equipped with RFID technology widely [4,5].

Some advantages of RFID technology are [6]:

- Low cost form of data collection and asset management.
- Enables data collection in harsh environments that are unsuitable for workers.
- Able to provide many reads and write functions per second, although it is not a very high data rate system, it is sufficient for most data monitoring applications.
- Data on an RFID tag can be altered repeatedly.
- Can be used with existing systems including bar codes and WiFi.

As a result, RFID technology is being increasingly used in many areas. RFID proximity cards are commonly used for building access control at many companies and universities throughout the world. Many subways and bus systems around the world, for example in Singapore, RFID proximity cards are used [7]. RFID devices began to be used for automated toll collection in the late 1980s and early 1990s. Electronic toll systems have been adopted since then around the world [7]. RFIDs are used in Passports (ePassport) in many countries. Personal data such as fingerprints and images are stored on the ePassport. Invention of NFC provides opportunity for individual application areas such as downloading information from smart posters, buying tickets for public transportation on the phone, or contact-less payment in shops [3]. Moreover, RFID electronic product code (EPC) currently replaces the optical bar-codes and EPCs are used in the areas of supply chain management, inventory control and retail checkout [7].

Other current applications of RFID technology are listed below [1, 7]:

- Tracking and identification eg. large containers, EPC, animal tracking.
- Contact-less credit cards.
- Concert and sport tickets.
- Anti-Counterfeiting systems eg. drugs, luxury goods, casino tokens.
- Airline baggage identification.

1.3. RFID Principles

This section discusses RFID fundamental basics, elements of RFID systems and types of RFID systems.

1.3.1. Theory of Operation

The RFID system consists of readers (also known as interrogators), tags (also known as transponders), and an information managing host computer. A sample RFID system shown in Figure 1.1 [8].

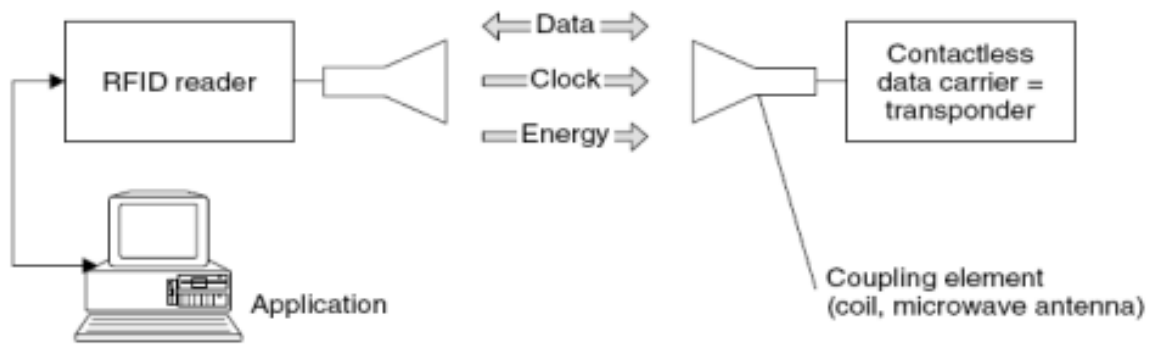

Figure 1.1. Sample RFID system.

Communication and power of the HF RFID system are achieved through electromagnetic coupling between the reader and the tag. The tag consists of an antenna coil and a silicon chip that includes basic modulation circuitry and non volatile memory. Passive RFID tags need an induced antenna coil voltage for operation from the reader. The reader antenna coil produces a time-varying magnetic field to energize the tag. When the tag and reader antennas are in close proximity, the time varying magnetic field induces a voltage in the tag antenna coil and the tag receives the required energy to operate from the field [8,9].

The tag receives energy as an AC voltage across the tag's coil. Then, the induced AC voltage is rectified to provide a voltage source for the microchip operation on the tag. The tag starts operating when the DC voltage reaches a certain level. Next, the

tag modulates the carrier signal according to the data stored on the tag and sends the data signal to the reader. Finally, the reader decodes the received information and sends it to a host computer [8, 10].

1.3.2. Tags

A tag is typically composed of an antenna or a coupling element along with an integrated chip. The tag antenna receives the supplied energy from the reader for operation and also transmits the information stored inside to the reader.

The tag antenna circuit must be designed to ensure that the magnetic coupling between the reader antenna and the tag antenna is maximum. In order to achieve this, the tag circuit must be tuned to the carrier frequency of the reader and the quality factor of the tuned circuit must be maximized within the limitations of the international protocols. Also, the antenna size should be maximized within the physical limit of the required application [5].

There are many types of tags that offer different functionalities, have different power sources, or operate at different radio frequencies. The tag type should be chosen based on the required application. The power source is an important property of a tag, as it will determine the tag's potential read range, lifetime, cost, and the kind of functionalities it may offer. There are three main classes of tag power sources: active, semi-passive, and passive.

Active tags have their own power source such as a battery. Active tags can initiate communication to a reader or other active tags. They have a much longer operating range than passive tags since they contain their own power source. Active tags are generally used in large assets and livestock tracking applications, because items need to communicate with the reader from high read distances [7].

Semi-passive (or semi-active) tags have an internal battery, but are not able to initiate communication. They are only active when queried by a reader. Semi-passive

tags offer a longer reader range than passive tags but their costs are more expensive.

An application example that often uses semi-passive tags is electronic tollbooths. When the car passes through a tollbooth, it will initiate a query to the semi-passive tag and read an account identifier from the tag. The on-board battery lets the tag be read from a considerable distance. However, since the tag only needs to broadcast when queried, it can remain idle most of the time and save power [7].

Passive tags do not have an internal power supply and they are powered by the incoming RF communication signal from the reader. Even though passive tags have the shortest read range, they are the cheapest to manufacture and the easiest to integrate into products. Also, their lifetime is almost indefinite because they don't need battery. EPC tags and smart cards are generally passive.

When choosing the type of tag for an application, it is necessary to determine its requirements and whether an active RFID tag or a passive RFID tag is needed. Table 1.1 compares various properties of passive, semi-passive, and active tags [7].

Table 1.1. Comparison of passive, semi-passive, and active tags.

Tag Types	Passive	Semi-Passive	Active
Power Source	Harvest the RF energy	Battery	Battery
Communication	Responses only	Responses only	Responses or initiates
Max Range	1 m	>100 m	>100 m
Relative Cost	Least expensive	More expensive	Most expensive
Example Application	EPC, proximity cards	Electronic tolls, tracking	Large asset tracking, livestock tracking

RFID tags may be able to either perform as a read only or read-write. Read only RFID tags include a unique identifier and other specified data that cannot be changed. This type of tags are typically programmed in the producer side and the user can not change the unique ID. Read-write RFID tags can be rewritten many times [6].

1.3.3. Readers

RFID readers are used to activate passive tags with RF energy and to extract information from the tag. The reader includes RF transmission, receiving and data decoding sections. In addition, the reader often includes a serial communication (RS-232, USB, UART, Ethernet, or wireless systems including WiFi, Bluetooth, or Zigbee etc.) capability to communicate with a host computer.

The RF transmission section includes an RF carrier generator, antenna and a tuning circuit. The reader antenna transmits the electromagnetic energy to energize the tag, realizes the data transfer and sends the instructions to the tag. Meanwhile, the reader antenna receives information from the tag. The antenna and its tuning circuit must be properly designed and tuned for best performance [5].

Data decoding for the received signal is accomplished by using a micro controller. The firmware algorithm in the micro controller is written in such a way to transmit the RF signal, decode the incoming data and communicate with the host computer [5].

Readers come in many forms, operate on many different frequencies, and may offer a wide range of functionality. Different standards are defined for RFIDs in the LF/HF/UHF/Microwave bands. Classification of readers by operation frequency is discussed in Section 1.3.6.

1.3.4. Databases and Application Software

RFID databases associate tag-identifying data with arbitrary records. These records may contain product information, tracking logs, sales data, expiration dates etc. [7].

1.3.5. Antenna

Antenna design is always the key part of the RF system, since it is a vital device for transmitting and receiving RF power from space. Antenna performance greatly affects the performance of the whole system. During the communication process, the reader antenna coil has two main functions [10]:

- i transmitting the drive signal to the tag and providing voltage source for the tag,
- ii receiving the data signal which comes from the tag.

These two points show that the available magnetic flux around the reader antenna coil should be maximized to ensure that the tag antenna coil can produce the largest induced voltage. The bandwidth of the antenna coils needs to be wide enough to ensure that the data carrier signal can be with no distortion.

The reader and tag antenna must match to achieve maximum antenna current flow. If the antennas of the reader and the tag are not designed correctly, inductive coupling will not occur and the desired tag will not be activated. Thus, the RFID application fails [8].

The coupled power and the transmission efficiency between two antenna coils are related to many kinds of factors, such as the working frequency, the turns of the antenna coils, the area of the antenna coils, the distance between the two coils and relative angles of the two coils [11]. The effect of each parameter and the design guide for appropriate antenna are described in Chapter 2.

1.3.6. Operating Frequencies

The carrier is the transmitted radio signal of the reader. This RF carrier provides energy to the tag device, and is used to detect modulation data from the tag. In read/write devices, the carrier is also used to deliver the tags commands and data to the tag. RFID readers can be classified by their carrier frequencies. It is usually

only possible to use specific frequency ranges that have been reserved specifically for industrial, scientific or medical applications or for short range devices [1]. Typical RFID carrier frequencies are [5]:

- 125 kHz
- 13.56 MHz
- 900 MHz
- 2.45 GHz
- 5.8 GHz

Each range of frequencies offers its own operating range, power requirements, and performance. The operating frequency is also important in determining the physical dimensions of an RFID antenna. The frequency bands must be selected carefully for the required application because each frequency has its own advantages and disadvantages. Table 1.2 lists standard frequencies and their effects in RFID systems [7].

Table 1.2. Common operation frequencies for RFID applications.

Frequency	Antenna Components	Read Range	Penetration	Usability in Metal Environment
LF	Coil	Proximity	Best	Possible
HF	Coil	Medium	Good	Possible
Microwave	E-field dipole	Long	Poor	Difficult

Low frequency (LF) RFID tags typically operate in the 125 kHz. Most commonly, LF tags are passively powered through induction. As a result, they typically have very short read ranges. LF tags can be used in harsh environments and can operate in proximity to metal, liquids, or dirt. This makes them useful for applications like implantable pet identification tags or laundry management tags. One disadvantage of LF tags is that they have a very low data read rate compared to other operating frequencies [7].

High frequency (HF) RFID tags operate at 13.56 MHz frequency. HF tags are often packaged in a foil inlay or in a credit card form. This makes HF tags useful for building access control, contact-less credit cards, and ID badges. HF tags offer a higher data read rate than LF tags and provide better performance near metals or liquids than UHF tags [7].

UHF tags operate at 860-960 MHz range and they are most commonly used for item tracking and supply chain management applications. They offer higher read range than LF and HF. A major disadvantage of UHF tags is that they experience interference in proximity to liquids or metals. Many applications like animal tracking, metal container tracking, or even many access control systems are infeasible with UHF tags. UHF readers may also interfere with sensitive electronics like medical equipment [7].

Microwave tags operate at either 2.45 or 5.8 GHz. Microwave RFID technology has come into use fairly recently and is rapidly developing. Microwave tags used in practice are typically semi-passive or active, but may also come in passive form. Semi-passive microwave tags are often used in fleet identification and electronic toll applications [7].

Microwave systems offer higher read rates than UHF and equivalent passive read ranges. Also, physical implementations of microwave RFID tags may be much smaller and compact than lower frequency RFID tags. The major disadvantage of microwave tag is that they are typically more expensive than UHF tags. Another problem is that wireless 802.11b/g (WiFi) networks may interfere with microwave RFID systems. Devices implementing the upcoming ZigBee 802.15 wireless standard could also potentially conflict with microwave RFID devices as well [7].

1.4. Coupling Types

There are several ways in which the RFID reader can communicate with the RFID tag. The type of coupling used affects several aspects of the RFID system including

the range, operating frequency etc. The RFID antenna coupling must be taken into account when designing the antennas. The choice of the best form of RFID coupling depends on the intended application. The main RFID coupling techniques used are [6]:

- RFID capacitive coupling
- RFID inductive coupling
- RFID backscatter coupling

Capacitive RFID coupling is used for very short ranges, inductive RFID coupling for slightly longer ranges and RFID backscatter coupling is normally used where longer distances are needed.

1.4.1. RFID Capacitive Coupling

RFID capacitive coupling is used for short ranges. Due to the fact that the reader and tag have conductive patches, the patches form a capacitor when they are placed very close and parallel. The capacitance between the reader and tag provide a capacitor through and the AC signal generated by the reader is picked up and rectified within the RFID tag and used to power the devices within the tag. Data is sent to the RFID reader by load modulation. RFID capacitive coupling operates best when items like smart cards are inserted into a reader [6].

1.4.2. RFID Inductive Coupling

RFID inductive coupling is normally used on the lower RFID frequencies, below 135 kHz or at 13.56 MHz. As shown in Figure 1.2, inductively coupled systems are based upon a transformer-type coupling between the primary coil in the reader and the secondary coil in the tag. RFID inductive coupling is a near field effect. Accordingly, the distance between the coils must be kept within the range of about 0.16λ , where λ is the wavelength of the frequency in use [1, 6].

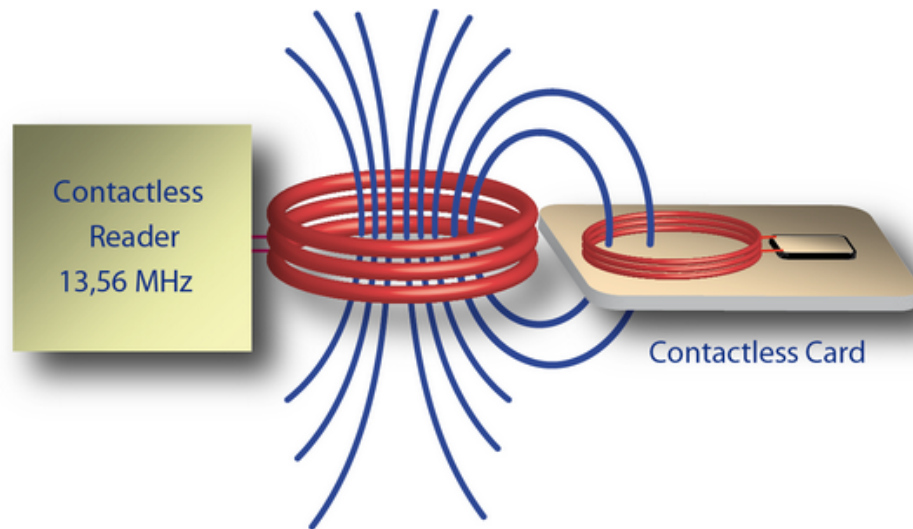

Figure 1.2. Inductive coupled RFID system.

In inductive coupling, energy is transferred from one circuit to another via the mutual inductance between the two circuits. For RFID inductive coupling to be used, both the tag and the reader will have induction or antenna coils. When the tag is placed close enough to the reader, the reader antenna coil will couple to the coil of the tag. Then, induced voltage in the tag is rectified and powers the tag circuitry. To enable data to be passed from the tag to the reader, the tag circuitry changes the load on its coil and this can be detected by the reader as a result of the mutual coupling.

Inductively coupled systems are almost always operated passively. Therefore, all the energy needed for the operation of the tag has to be provided by the reader. Therefore, the reader's antenna coil generates a strong field to provide sufficient energy for the tag. The tag's antenna draws energy when it is placed within the magnetic alternating field of the reader's antenna. This additional power consumption can be measured as a voltage drop at the internal resistance in the reader antenna through the supply current to the reader's antenna. The on and off switching of a load resistance at the tag's antenna causes voltage changes at the reader's antenna. Thus, there is an amplitude modulation effect of the antenna voltage by the remote tag. If the on and off switching of the load resistor is controlled by data, then this data can be transferred from the tag to the reader. This type of data transfer is called load modulation [1].

1.4.3. RFID Backscatter Coupling

Electromagnetic waves are reflected by objects with dimensions greater than around half the wavelength of the wave. The efficiency with which an object reflects electromagnetic waves is described by its reflection cross-section [1].

RFID backscatter coupling uses the RF power transmitted by the reader to energize the tag. The reader transmits a modulated signal with periods of unmodulated carrier, which is received by the tag antenna. The RF voltage developed on antenna terminals during the unmodulated period is converted to DC. This voltage powers up the chip, which sends back the information by varying its front end complex RF input impedance. The impedance typically toggles between two different states, between conjugate match and some other impedance, effectively modulating the backscattered signal [12]. Depending on whether either the resistance or reactance is varied, the backscattered carrier is modulated with ASK or PSK, respectively [13].

1.5. NFC

Near Field Communication, is a standard based technology used to provide short range wireless connectivity technology that carry secure two way interactions between electronic devices. NFC near field communication provides contact-less communication up to distances of about 5 centimetre. In this way, communications are inherently more secure because devices normally only come into contact and hence communication when the user intends this.

NFC utilizes inductive coupling, and operates at a frequency of 13.56 MHz within the globally available and unregulated 13.56 MHz frequency band. NFC is a form of RFID, but it has a specific set of standards governing its operation, interface, etc. This means that NFC equipment, and elements from a variety of manufacturers can be used together. The NFC standards determine not only the contact-less operating environment, but also the data formats and data transfer rates. NFC is used in a variety of applications such as [6]:

- Mobile phones, PDAs etc.
- Personal computers.
- Check-out cash registers or point-of-sale equipment.
- Turnstiles.
- Vending machines.
- Parking meters.
- ATMs.
- Applications around the office and house, e.g. garage doors etc.

NFC is ideally placed to provide a link with the contact-less smart card technology that is already used for ticketing and payment applications. It is broadly compatible with the existing standards that have been set in place. Therefore, NFC enabled devices could be used for these applications as well. NFC has standards accepted by ISO (18092), and ETSI. Additionally, NFC is compatible with ISO 14443 A and Sony's FeliCa smart card protocols [6].

1.5.1. NFC Technology Device Types

The NFC standard defines two types of NFC devices: the initiator and target of the communication. The initiator is the device that initiates the communication and it controls the data exchanges. The target device is the one that responds to the requests from the initiator. The NFC standard defines two different modes of operation [6]:

- (i) Active mode of communication: Both devices generate an RF signal on which the data is carried.
- (ii) Passive mode of communication: Only one NFC device generates an RF field. The second passive device which is the target uses a technique called load modulation to transfer the data back to the primary device or initiator.

In addition to the NFC modes of operation, three communication modes are also defined [6]:

- (i) Read/Write: Allows applications to transfer data in an NFC Forum-defined message format.
- (ii) NFC card emulation: Enables the NFC device to behave as a standard smart card.
- (iii) Peer to peer: Supports device to device link-level communication.

1.5.2. NFC RF Signal Coding

Using ASK (amplitude shift keying) modulation, most of the RF energy is concentrated in the allowed 14 kHz bandwidth, although the side bands may extend out as far as ± 1.8 MHz. NFC employs two different coding systems on the RF signal to transfer data. In most cases a level of 10% modulation is used, with a Manchester coding format. However for an active device transmitting data at 106 kBps, a modified Miller coding scheme is used with 100% modulation. In all other cases, Manchester coding is used with a modulation ratio of 10%. Coding types of NFC devices are shown in Table 1.3 [6].

Table 1.3. NFC coding types.

Data Rate	Active Device	Passive Device
106 kbps	Modified Miller, 100%, ASK	Manchester, 10%, ASK
212 kbps	Manchester, 10%, ASK	Manchester, 10%, ASK
424 kbps	Manchester, 10%, ASK	Manchester, 10%, ASK

1.5.3. Manchester Coding

Manchester coding is used for the majority of cases for NFC communications. The Manchester coding utilizes the two different transitions that may occur at the midpoint of a period. A low-to-high transition expresses a 0 bit, whereas a high-to-low transition stands for a 1 bit. To achieve these conditions it is sometimes necessary to have a transition at the middle of a bit period. Transitions at the beginning of period

are disregarded [6].

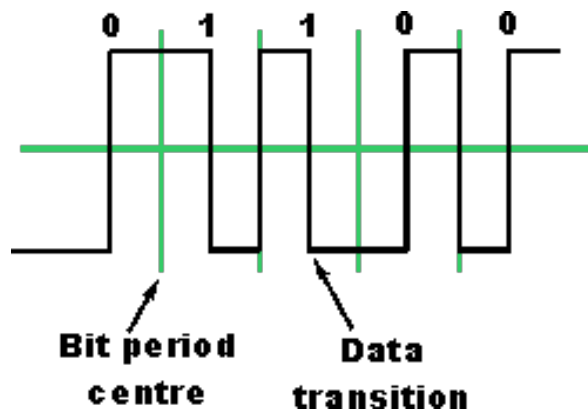

Figure 1.3. Manchester coding used for NFC data transfer.

1.5.4. Modified Miller Coding

Modified Miller code is a little less intuitive, but provides an efficient form of coding. It is characterized by the pauses occurring in the carrier at different positions of a period. Depending on the information to be transmitted, bits are coded as shown below. A high or 1 is always encoded in the same way, but a low or 0 is encoded differently dependent upon what preceded it. Figure 1.4 shows Modified Miller coding used for NFC data transfer used for 106 kbps active device transfers [6].

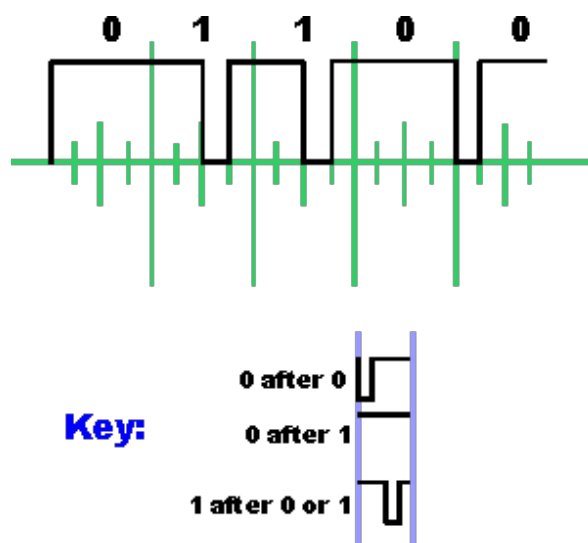

Figure 1.4. Modified Miller coding.

1.6. ISO Communication Standards

The most relevant RFID standards are the ISO/IEC 18000 standard. The ISO 18000 standard has 6 parts addressing different frequency ranges:

- Part 1 General standards.
- Part 2 LF.
- Part 3 HF.
- Part 6 UHF.
- Part 4 Microwave (2.45 GHz).
- Part 5 Microwave (5.8 GHz).

Two other ISO standards, ISO/IEC 14443 and ISO/IEC 15693 are related to smart card and proximity card interfaces operating in the HF range.

Inductive coupled RFID systems operated in the 13.56 MHz band are primarily covered by the ISO/IEC standards ISO 14443, ISO 15693, and ISO 18000-3 and 18092. The majority of applications operate according to ISO/IEC 14443. This standard is designed for high security communication with smart card tags at proximity distances of 10 cm or less. The wave shapes of the signal at the air interface are well defined in this standard and following standard guarantees that different systems can communicate with each other [1, 14, 15].

1.7. EMC Regulations for RFID Applications

The radiated power by the reader and limitations on spurious emissions are defined by the regulation of each country. Each country has its own regulations, for physical parameters, such as allowed field strength, frequency or bandwidth. This guarantees that different radiating systems do not influence each other.

NFC and contact-less smart cards are known as proximity coupling devices (PCD) or short range devices (SRD) and operate in the 13.56 MHz frequency band. Before

market entry, a sample of each new reader product must pass the certification at an accredited test lab regarding emission limits. For European countries, the ERC 70-03 defines the limit values and a spectral mask, and the EN 300330 defines the measurement method [16,17]. Table 1.4 shows the allowed field strength for different RFID frequencies [6].

Table 1.4. Allowed field strength of common RFID operating frequencies.

Frequency Range	Comment	Allowed field strength / transmission power
<135 kHz	low frequency and inductive coupling	72 dB μ A/m max
13.553 -13.567 MHz	inductive coupling, contact-less smart cards (ISO 14443), smart labels (ISO 15693) and item management (ISO 18000-3)	60 dB μ A/m
865.6 -867.2 MHz	UHF (RFID only)	2W ERP Europe only
2.446 - 2.454 GHz	SHF (RFID)	0.5 W EIRP outdoor 4 W EIRP indoor
5.725 - 5.875 GHz	SHF (ISM), backscatter coupling	4 W USA/Canada, 500 mW Europe

The H-field emission limit for the 13.56 MHz range is specified that H-field level should be maximum 60 dB μ A/m at 7 kHz around the carrier frequency. The emission limit for the modulation bandwidth of ± 150 kHz is 9 dB μ A/m [3]. The challenge is to find a modulation, which allows the system to be compliant to frequency regulation and as well as the mask for emission limits. Moreover, it has to be ensured that enough power is transmitted to supply passive cards.

2. ANTENNA DESIGN CRITERIAS

In this chapter, fundamental parameters of HF RFID antennas are described. Also, key parameters to design a proper antenna are presented. Before beginning the reader antenna design, first the desired RFID application should be selected and system requirements can be translated into the reader requirements.

2.1. Desired Application

The reader antenna in this work is designed specially for a TV application. Consider a school, hospital or company where there is a public TV with secure and user defined applications. This design enables special users with user defined tags to access their personal menu and operating system in TV. Thus, other users will be prevented to access restricted applications even though they can use public applications.

The reader antenna and reader circuit is placed into the TV set in the depth of about 1 cm from the front cover. Thus, minimum communication range should be greater than 1 cm. In this work, achieving maximum read distance is aimed but RFID reader is worked like an access control system, thus system sensitivity and accuracy is much more important than maximum read range. Missed and wrong readings will affect the system's performance and reliability greatly.

Since the reader antenna is placed in the TV system, then it's size should be small enough. Furthermore, system should not be effected the environment and should be low in cost. Considering all of these parameters, an HF reader system with an operating passive cards is aimed to design. The sample passive tags which can be used in this work are sold for about 0.2 USD commercially.

2.2. Design Steps

First, the special application and design requirements of the RFID reader are determined and the material to be used in the antenna construction is selected. Then, the reader antenna is modelled, simulated, and optimized on a simulation tool. Return loss and complex and real impedance at the desired frequency give designer a good understanding of the antenna behaviour. At last, prototypes are built and their performance is measured experimentally. If the design requirements are satisfied, the antenna design is ready. Otherwise, the design is further modified and optimized until requirements are met.

The process of antenna design is briefly described below:

- **Materials:** Because of cost and application considerations, FR4 substrate with a dielectric permittivity of 4.6 and a thickness of 1.5 mm is selected. Top antenna trace was made of copper and had a thickness of 35 μm .
- **Main IC:** For this application, NXP PN531 chip is selected on antenna terminals [18]. This chip is one of the most commercially used chip in HF reader designs.
- **Antenna type:** In this work, rectangular loop antenna is used.
- **Parametric study and optimization:** The loop antenna has several key parameters: diameter, spacing, antenna length, antenna width and number of turns. The optimal realizable combinations of reader antenna parameters were identified by plotting and examining the simulation results. The determined parameters and simulation results are given in Chapter 3. After optimization, final parameter values for the reader antenna are determined.

2.3. Simulation Tool

Antenna design based on numerical methods has been applied to design antennas for various systems. Familiar numerical methods include Method of Moment (MoM), Finite Element Method (FEM), and Finite Difference Time Domain (FDTD).

Reader antennas are usually analyzed with electromagnetic modelling and simulation tools, typically using method of moments for planar designs (e.g. thin flexible readers) and with finite element method or finite-difference time-domain method for more complicated three-dimensional designs (e.g. thick metal mounted readers). The MoM can be used to calculate the antenna performance quickly and accurately, especially for some large antenna structures. The FEM and FDTD methods can be used directly to analyze the antenna performance. However, the FEM method gets more accurate results than the FDTD method. The FDTD method can be used to analyze some larger antenna structures, solve the wide band problems in time domain, and give a dynamic demo about the electromagnetic field distribution and radiation. Some tools such as HFSS, which are widely used to design antennas for RFID system, add the ability of automatically meshing to facilitate the user and improve the precision [19].

In this work, a complete passive RFID system simulation environment has been developed in Agilent ADS 2009. By means of this powerful simulation tool, the main design constraints that degrade reader performance can be analyzed [13].

2.4. Loop Antenna Basics

It is important that the device must be equipped with a proper antenna circuit for successful RFID applications because the energizing and communication between the reader and tag is accomplished through antenna coils [9].

For lower frequencies, the RFID reader antenna may comprise a coil, whereas for higher frequencies it may be a form of dipole element. With RFID up to 30 MHz typically using inductive coupling. This means that most antennas would comprise a coil, but at higher frequencies where radiative systems are used and the wavelengths are much shorter, forms of dipole offer good performance [6].

The RFID reader in this work operates in the HF band at 13.56 MHz and the reader antenna utilizes the magnetic field to transfer power to the battery-less tag during reading and writing operations. Due to the fact that the wavelength is propor-

tional to the antenna dimensions, designing electrically small antennas in 13.56 MHz frequency with a wavelength of 22.12 meters is a very challenging task. Therefore, it is difficult to form a true antenna for most RFID applications. Alternatively, a small loop antenna circuit that is resonating at the frequency is used [9]. Of all the antennas that can be used to excite a magnetic field, loop antennas are recommended as the most suitable for generating the magnetic field that is required to transfer energy to the HF passive tag [9]. A copper loop antenna is chosen for its ductility, solidity and performance [8]. Reader antenna performance depends on [20]:

- Antenna sizes.
- Number of turns.
- Track diameter and spacing.
- Track material.
- Environmental impacts.

Effects of these parameters are described in next sections.

2.4.1. Antenna Inductance

The physical dimensions of a rectangular planar antenna with greater than one turn is shown in Figure 2.1 [21].

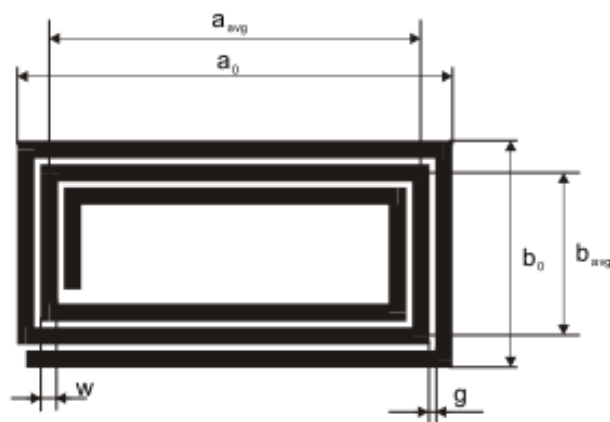

Figure 2.1. Modelling rectangular planar antenna.

The inductance can be modelled by thre following formula [21]:

$$L_a = \frac{\mu_0}{\pi} \times [x_1 + x_2 - x_3 + x_4] \times N_a^{1.8} \quad (2.1)$$

where

$$d = 2 \frac{(t + w)}{\pi} \quad (2.2)$$

$$a_{avg} = a_0 - N_a \times (g + w) \quad (2.3)$$

$$b_{avg} = b_0 - N_a \times (g + w) \quad (2.4)$$

$$x_1 = a_{avg} \times \ln \left[\frac{2 \times a_{avg} \times b_{avg}}{d \times (a_{avg} + \sqrt{a_{avg}^2 + b_{avg}^2})} \right] \quad (2.5)$$

$$x_2 = a_{avg} \times \ln \left[\frac{2 \times a_{avg} \times b_{avg}}{d \times (b_{avg} + \sqrt{a_{avg}^2 + b_{avg}^2})} \right] \quad (2.6)$$

$$x_3 = 2 \times [a_{avg} + b_{avg} - \sqrt{a_{avg}^2 + b_{avg}^2}] \quad (2.7)$$

$$x_4 = \frac{[a_{avg} + b_{avg}]}{4} \quad (2.8)$$

where variables;

- a, b : Overall dimensions of the coil
- a_{avg}, b_{avg} : Average dimensions of the coil
- t : Track thickness
- w : Track width
- g : Gap between tracks
- N_a : Number of turns
- d : Equivalent diameter of the track [22]

2.4.2. Magnetic Field Strength of the Antenna Coil

The antenna coil of a square conductor loop and the side of the square loop is shown in Figure 2.2 [10],

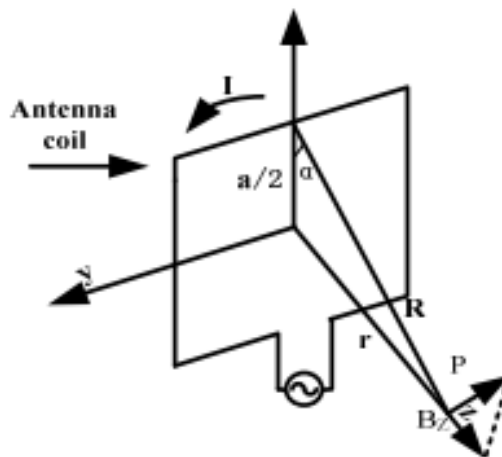

Figure 2.2. The representing graph of the magnetic field strength of the N turn square loop.

The magnetic field strength B which is in the plane of the vertical distance r from the center of the square loop can be formulated as [10],

$$B_z = \frac{\mu_0 I N a^2}{2\pi \sqrt{(a/2)^2 + r^2} [(a/2)^2 + r^2]} (Wb/m^2) \quad (2.9)$$

for $r^2 \gg a^2$;

$$B_z = \mu_0 I N a^2 / 2\pi r^3 (\text{Wb/m}^2) \quad (2.10)$$

where μ is the constant of the magnetic field, which is the permeability of air given as $4\pi \cdot 10^{-7}$ H/m. N is the number of turns in the antenna coil, I is the current which is going through the antenna coil. Equation 2.10 indicates that the magnetic field strength decays with $1/r^3$ [10]. This near field decaying behavior of the magnetic field is the main limiting factor in the read range of the RFID device.

2.4.3. Induced Voltage

Faradays law states a time-varying magnetic field through a surface bounded by a closed path induces a voltage around the loop. When the tag and reader antennas are within a proximity distance, the time-varying magnetic field B that is produced by a reader antenna coil induces a voltage (electromotive force) in the tag antenna coil. The induced voltage in the tag coil V_a causes a flow of current in the coil. The Equation 2.11 indicates that the induced voltage in the tag coil is inversely proportional to the square root of the coil tag inductance, but proportional to the number of turns and surface area of the coil [23].

$$V_a = 2\pi f N_a Q S B_0 = V_a = 2\pi f N_a (R \sqrt{\frac{C}{L}}) S B_0 \quad (2.11)$$

where,

- f : frequency of the arrival signal
- S : area of the loop in square meters
- B_0 : magnetic field strength of the arrival signal
- α : angle of arrival of the signal

2.4.4. Number of Turn

Increasing the number of ampere-turns, increases the B field. Therefore, larger read ranges can be achieved. However, there are drawbacks to this option as the more turns the antenna is, the less portable and more expensive the reader becomes.

The consequence of increasing number of turn is a larger inductance in the reader antenna circuit that increases as the square of the number of turns. A high inductance load results in large amounts of reflected power as well as a large impedance that varies significantly. Therefore, it is important to keep number of turn as small as possible while achieving the minimum B field needed for the desired read range [8].

Depending on the antenna size, the number of turns should be chosen in a way to achieve a few μ inductance. Very low inductance values become increasingly difficult to match and the margin for error becomes very small. The parasitic capacitance should be kept low to achieve a self-resonance frequency ≥ 35 MHz. For many applications and antenna sizes, the number of turns will be in the range $N_a = 1-6$. A low number of turns is preferred to minimize the effects of coupling between antennas [11].

2.4.5. Antenna Symmetry

The symmetry in antenna design is absolutely necessary with respect to tuning and EMC behavior as shown in Figure 2.3. Otherwise, common mode currents are generated due to parasitic capacitances from the antenna to ground. These currents can cause emissions that hurt the EMC regulations [21].

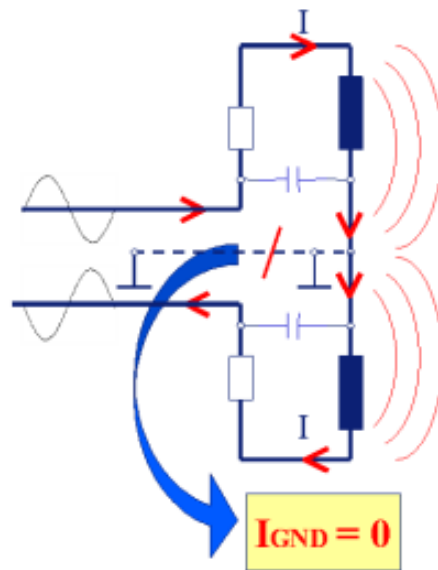

Figure 2.3. Ground current compensation.

Figure 2.4 shows an example of a symmetric 4 turn antenna design. It can be seen that the center tap of the antenna is connected to ground. Basically, it is not recommended grounding the center tap, instead leaving it floating. This has the advantage of a virtual ground point which is floating to achieve symmetry of the antenna [21].

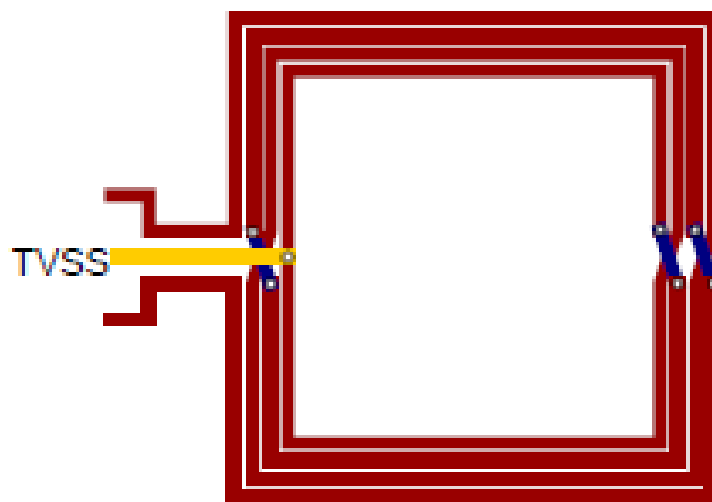

Figure 2.4. 4 turn symmetric antenna example.

2.4.6. Antenna Size

The larger the reader antenna loop is, the more current carrying parts add a contribution to the magnetic field. If the loop becomes too large, however, these contributions become very weak due to the large distance from the current carrying part to the tag. Furthermore, if the total wire length of the loop becomes a considerable part of the wavelength of 22.12 m, the standing waves will cause multiple resonances and decreases the total field. Hence, the antenna dimension is determined experimentally to provide the sufficient magnetic field [8].

2.5. System Performance

Read/write range is the communication distance between the reader and tag. Specifically, the read range is the maximum distance to read data out from the tag and the write range is the maximum distance to write data from the reader to the tag [5].

The read/write range is related to [5]:

- Electromagnetic coupling of the reader and tag antennas.
- RF Output power level of reader.
- Carrier frequency bands.
- Power consumption of the device.

2.6. Design Considerations

A number of issues have to be taken into consideration before the design of an antenna can begin [8].

2.6.1. Proximity of Metal

The performance of RFID systems is strongly dependent on the surrounding environments in which the communication between the reader antennas and the tags

occurs. Many materials such as metals and liquids, which are close to the reader and tag antennas, may degrade the performance of the RFID systems by changing the characteristics of the antennas in terms of impedance matching and field distribution [24].

The presence of metal close to an antenna will reduce its performance to some extent. As the antenna is placed close to metal plate, the metal will detune the parameters and also generate eddy current to cancel the electromagnetic wave generated by the reader [25]. As a result, the read distance will drop. Based on the results shown in studies, it is found that the resonant frequency of the loop antenna in the proximity of the metal plate is always shifted upwards with a corresponding reduction in the field intensity. The effect of the back-placement plate is more severe than the bottom-placement and/or side-placement metal plate configurations. The majority of the magnetic flux is blocked such that a larger eddy current is generated, which dramatically reduces the inductance of the antenna. Therefore, a significant frequency shift is observed. To overcome this, the antenna must be placed a certain amount of distance from the metal [8, 24].

2.6.2. Quality Factor

The performance of an antenna is related with its Quality (Q) factor. The quality factor reflects the stored energy in the antenna. The emitted power of the alternating H-field of the reader strongly depends on the quality factor of the reader antenna resonance circuit. In general, the quality factor (Q) of a parallel and serial resonance circuit is defined as [3]:

$$Q = \frac{2\pi f_r L}{R_s} = \frac{R_p}{2\pi f_r L} \quad (2.12)$$

where f_r is the resonance frequency and L is the inductance of the antenna. A serial resistor R_s is defined in case of a serial resonance circuit and a parallel resistor R_p in case of a parallel resonance circuit. It can be seen that the quality factor is dependent

on the frequency and values of the equivalent electric components. A higher quality factor on the one hand decreases the supply power consumption of the reader for the same emitted H-field strength but on the other hand influences the effective spectral bandwidth of the system. A lower spectral bandwidth means a negative impact on the signal shaping and so affects data transmission [3]. The bandwidth (B) can also be calculated as [21]:

$$B = \frac{f_r}{Q} \quad (2.13)$$

The current in the loop antenna is the source for the emitted H-field, independent whether it is reactive or active current. The reactive current is increased using a higher Q factor. This allows to emit higher H-field amplitude on the expense of longer time constants and reduced modulation bandwidth. Beside this bandwidth limitation of the system itself, frequency regulation limits the usage of the modulation bandwidth [3,26]. The bandwidth B-pulse width multiplied by T (maximum timing limit) is defined as [21]:

$$B.T \geq 1$$

Using the bandwidth definition given in Equation 2.13, if B multiplied by T (the maximum timing limit of 3 μ s is defined in the ISO 14443 standards for a modulation pause) results into;

$$Q \leq f_r.T$$

$$Q \leq (13.56 \text{ MHz}).(3 \mu\text{s})$$

$$Q \leq 40.68$$

It is shown that maximum allowable quality factor of circuit is limited to 40 in order to follow ISO limitations.

3. READER AND ANTENNA DESIGN

In this chapter, HF RFID reader circuit and antenna design and calculation of all parameters for the intended application are described. Furthermore, simulation, experimental and optimized results are presented.

3.1. Main IC

At the beginning of the design, the transmission module for contact-less communication at 13.56 MHz should be selected. In this design, NXP PN531 transmission module that combines modulation and demodulation for contact-less communication is used. The PN512 transmission module supports the Read/Write mode for ISO/IEC 14443 A/MIFARE and ISO/IEC 14443B using various transfer speeds and modulation protocols. This module is one of the most common IC for HF NFC applications. PN512 transceiver IC supports the following operating modes [18]:

- Reader/Writer mode supporting ISO/IEC 14443A/MIFARE and FeliCa scheme.
- Card Operation mode supporting ISO/IEC 14443A/MIFARE and FeliCa scheme.
- NFCIP-1 mode.

The following requirements have to be met by the amplifier circuit for NXP contact-less reader [22]:

- Generate the RF field: The generated magnetic field has to be maximized considering the limits of the transmitter supply current and general emission limits.
- Transmit data: The coded and modulated data signal has to be transmitted in a way, that every card and NFC device is able to receive it. The signal shape and timing has to be considered.
- Receive data: The response of a card or NFC device has to be transferred to the receive input of the PN531 considering the data sheet limits like maximum voltage and receiver sensitivity.

The operating distance of NXP contact-less NFC reader ICs depends on [22]:

- Matching of the antenna.
- Sensitivity of the receiver.
- Antenna size used in the reader system.
- Antenna size of the communication partner.
- External parameters (e.g. metallic environment and noise).

The example application circuit of PN531 transmission module is shown in the Figure 3.1 [18].

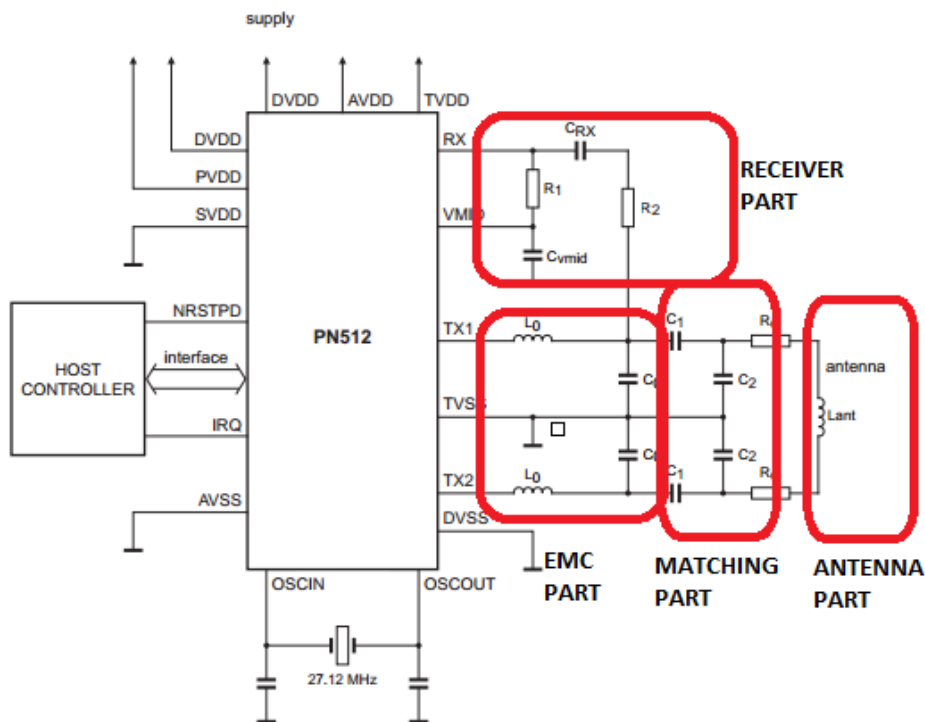

Figure 3.1. Sample application diagram of PN531.

The two branches of the differential network which connects the antenna to the driver output are identical. The differential output allows to have an output voltage of almost twice the supply voltage, and thus reduce the power losses in the output driver. Furthermore, a differential driver stage due to compensation always means a better noise suppression for the rest of the circuit. Therefore, the total output power is split up into two sources, which drive the output signal in phase opposition [26].

The main IC should be tuned to a centre frequency of 13.56 MHz with and proper antenna and other parts and have a 50 ohm impedance. For optimum performance, the reader circuit should have a Voltage Standing Wave Ratio (VSWR) ratio of less than 1.2 [8]. In the next sections, designing of the antenna, EMC part, matching part and receiver part in order to achieve desired resonance at carrier frequency of 13.56 MHz are presented.

3.2. Antenna Design

An antenna simultaneously stores charge as capacitance (mainly defined by the diameter and length of antenna wires), opposes changes in current as inductance (mainly defined by the size and number of turns of the antenna), and radiates power as resistance (mainly defined by the distance of antenna wires from each other and number of turns). From the electrical point of view, an antenna looks like an R-L-C circuit. The configuration of the circuit depends on the antenna type. A loop antenna that is short compared to the wavelength looks like a series combination of an inductor and capacitor with some resistance. The inductance and capacitance are both roughly proportional to the length of the antenna [20, 27].

Choosing the size and type of antenna circuit depends on the system design topology. The first step in antenna design is to obtain the series and parallel equivalent circuit models. The series resonant circuit results in minimum impedance at the resonance frequency. Therefore, it draws a maximum current at the resonance frequency. Because of its simple circuit topology and relatively low cost, this type of antenna circuit is suitable for proximity reader antenna [9]. The series equivalent model of the antenna is shown in Figure 3.2 [21].

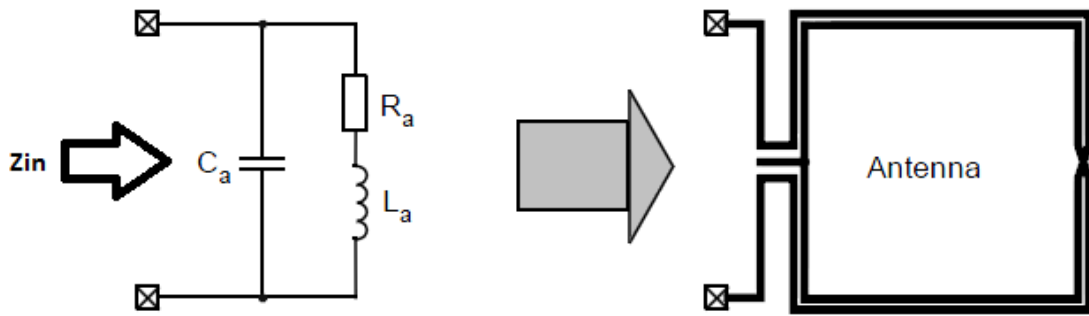

Figure 3.2. Series equivalent model for antenna.

On the other hand, a parallel resonant circuit results in maximum impedance at the resonance frequency. Therefore, maximum voltage is available at the resonance frequency. Although it has a minimum resonant current, it still has a strong circulating current that is proportional to Q of the circuit. The double loop antenna coil that is formed by two parallel antenna circuits can also be used [9]. It offers minimum current and maximum voltage at the resonance frequency. This parallel resonant circuit is used for the tag antenna [23]. The parallel equivalent model of antenna is shown in Figure 3.3 [21].

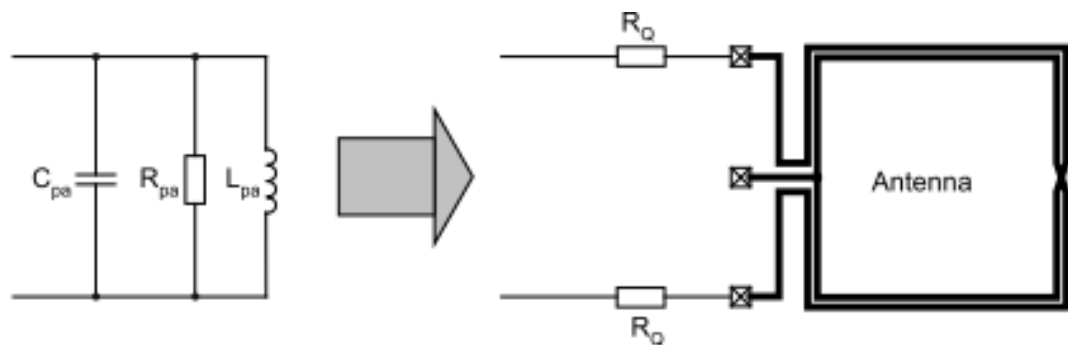

Figure 3.3. Parallel equivalent model for antenna.

First, the antenna's serial and parallel equivalent circuit models should be obtained by a simulation tool to calculate the other component values. All components should be calculate to achieve good resonance at the operation frequency $f=13.56$ MHz. The serial inductance and the serial resistance are measured at a frequency well below the self-resonance frequency of the antenna.

The inductance for the loop reader antenna for 13.56 MHz is typically in the

range of a few microhenries. Very low inductance values become increasingly difficult to match and the margin for error becomes very small. The reader antenna windings and the path to the antenna has a DC resistance of few ohms. A high resistance path impedes current flow which may result in an inadequate magnetic field [11].

In general, the bandwidth is inversely proportional to the Q factor, which is the ratio of the total reactance to the resistance. For a simple series resonant circuit, Q is about twice the voltage amplification factor. Thus, voltage amplification must be traded against bandwidth. Antennas with large reactance (large values of inductance and small values of capacitance) and small values of resistance may be adjusted to be matched to the tag at one frequency, with good power transfer and voltage multiplication, but performance will degrade at other frequencies. Antennas with small reactance will provide better performance over frequency [27].

Considering these restrictions and the physical constraint of the reader that is placed in the TV unit, antenna sizes and the number of turns are defined by parametric analysis in the ADS simulator. The dielectric material is chosen as FR4 being one of the most commonly used dielectric material for low cost applications. The physical dimensions of the antenna are shown in Table 3.1.

Table 3.1. Physical dimensions of the reader antenna.

a_0 (Overall dimensions of the coil) [mm]	b_0 (Overall dimensions of the coil) [mm]	t(Track thickness) [μm]	w (Track width) [mm]	g (Gap between tracks) [mm]	N_a (Number of turns)
61	34	35	0.38	0.25	6

The properties of the substrate material are shown in Table 3.2 and the layout of the modelled antenna is shown in Figure 3.4. Input impedance simulation results of modelled antenna by ADS Momentum analysis is seen in Figure 3.5.

Table 3.2. Properties of the dielectric material.

Dielectric Material	Permittivity	Thickness of dielectric	Conductor	Thickness of conductor
FR4	4.6	1.55 mm	Cu	35 μm (top and bottom)

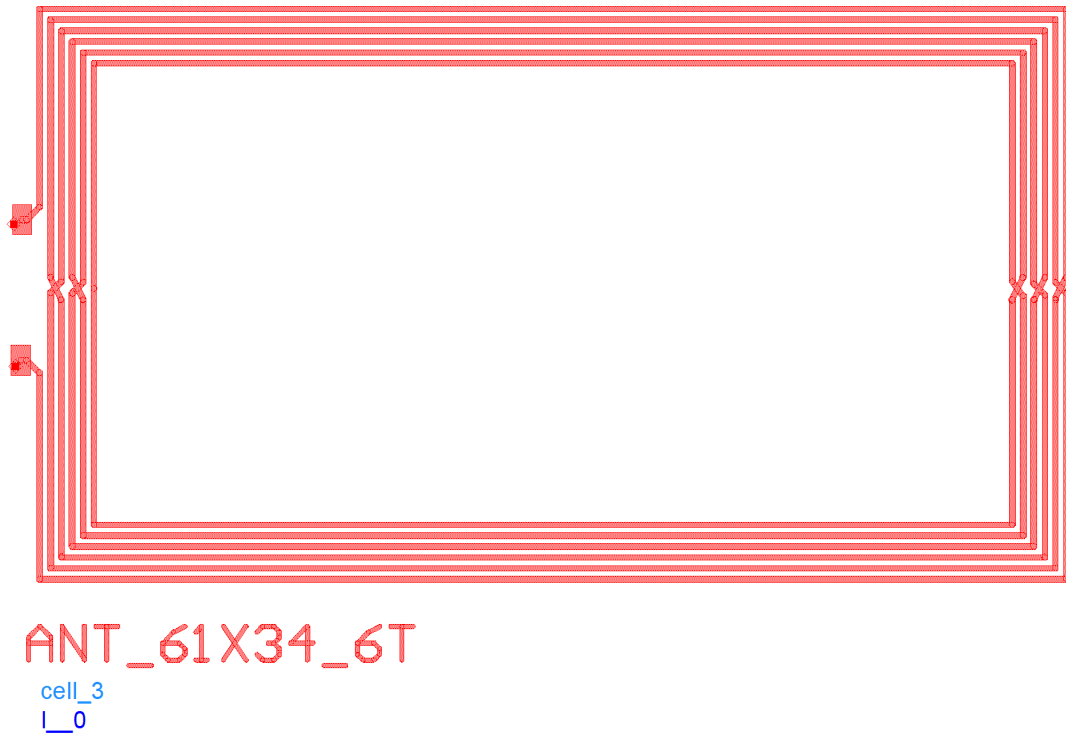

Figure 3.4. Reader antenna model.

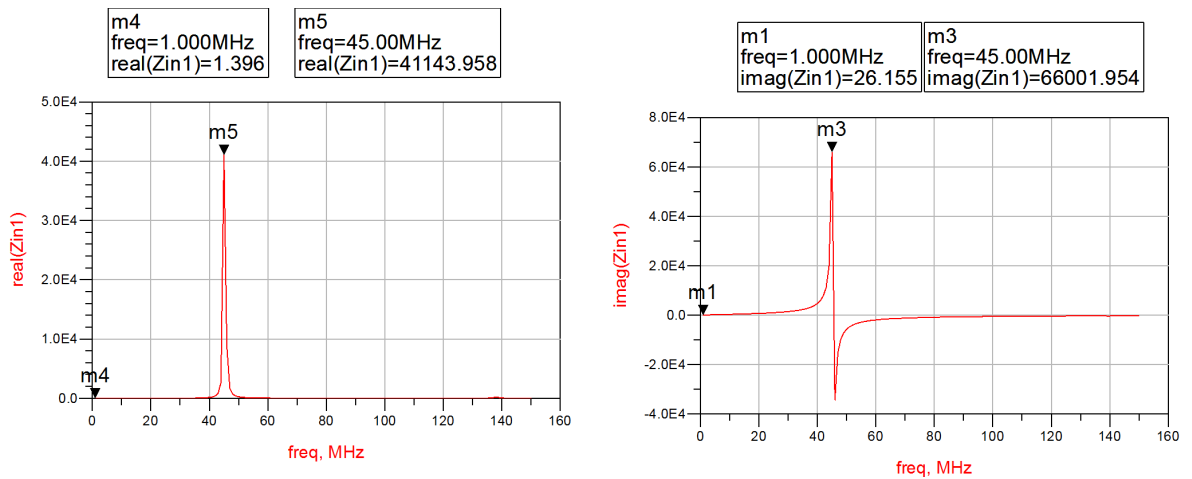

Figure 3.5. ADS input parameter simulation results.

Series inductance (L_a) and series resistance (R_s) values for the loop antenna are measured well below the self-resonance frequency of the antenna, but high enough for good measurement accuracy. Values of L_a and R_s S measured at 1 MHz frequency by the following formulas using the ADS results:

$$L_a = \frac{\text{imag}(Z_{in})}{2\pi f} = 4.15\mu H \quad (3.1)$$

$$R_s = \text{real}(Z_{in}) = 1.38\Omega \quad (3.2)$$

The self resonance frequency of the coil is determined at the point where the imaginary part of the input impedance crosses the positive axis to the negative axis. Self resonance frequency of the modelled antenna is measured from ADS results as;

$$f_{res} = 46.2 \text{ MHz}$$

The antenna's series equivalent resistance R_a is calculated both considering the parallel and series resistances of the antenna. The antenna's series equivalent resistance calculation is shown in Figure 3.6 below.

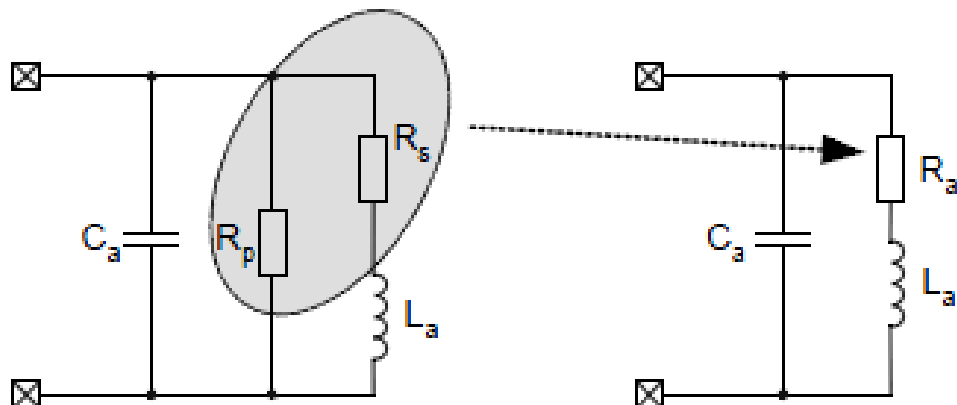

Figure 3.6. Antenna series equivalent resistance calculation.

The parallel resistance at the self resonance frequency is measured as $R_p = 41.2k\Omega$ and it is mainly caused by the skin-effect. As the antenna is intended to operate at

the carrier frequency (f_0) of 13.56 MHz, the value of the resistance has to be corrected according to the frequency dependency of the skin effect, giving a correction factor as shown in Equation 3.3 [26];

$$R_p(13.56MHz) = \sqrt{\frac{f_{res}}{f_0}} \times R_p = 76.05k\Omega \quad (3.3)$$

Therefore, the series equivalent resistance and the parallel equivalent resistance of the antenna are calculated by the Equations 3.4 and 3.5 :

$$R_a = R_s + \frac{(2\pi f_0 L_a)^2}{R_p(13.56MHz)} = 3.03\Omega \quad (3.4)$$

$$R_{pa} = \frac{(2\pi f_0 L_a)^2}{R_a} = 11.06k\Omega \quad (3.5)$$

The capacitance of the antenna (C_a) can be calculated by the Equation 3.6:

$$C_a = \frac{1}{(2\pi f_{res})^2 L_a} = 2.9pF \quad (3.6)$$

3.2.1. Quality Factor

The quality factor determines the sharpness or selectivity of this resonant circuit. When the Q factor is high, the antenna radiates more energy. The quality factor is the determining constraint because a high Q factor would lead to a limited bandwidth and long time constants, causing severe signal distortion in the test setup. The maximum quality factor providing bandwidth limitations of ISO14443A standard is $Q_a = 35$ as described in Section 2.6.2. Therefore, the external damping resistor (R_Q) as shown in Figure 3.3 is used to decrease quality factor to 35 [22, 26].

Quality factor of antenna can be calculated by,

$$Q_a = \frac{\omega_{res} L_a}{R_a} = 116.93 \quad (3.7)$$

The value of R_Q resistor can be calculated as,

$$R_Q = 0.5 \left(\frac{\omega_{res} L_a}{35} - R_a \right) = 4.38 \Omega \quad (3.8)$$

3.3. EMC Filter Part Design

The EMC filter circuit fulfils two functions: the filtering of the signal as well as the impedance transformation block. The EMC filter resonance frequency f_{r0} has to be near the upper side band frequency determined by the highest data rate (848 kHz sub carrier) in the system to achieve broadband receiving characteristics [22].

The, LC low pass EMC filter is shown in Figure 3.1. L_0 is chosen as 560nH and f_{r0} is calculated as;

$$f_{r0} \geq 13.56 \text{ MHz} + 848 \text{ MHz} = 14.408 \text{ MHz} \text{ and chosen as } f_{r0} = 14.4 \text{ MHz.}$$

C_0 is calculated as,

$$C_0 = \frac{1}{(2\pi f_{r0})^2 L_0} = 221.2 \text{ pF} \quad (3.9)$$

3.4. Matching Part Design

The near field communication channel is mainly determined by the coupling of two resonant loop antennas and their HF system properties. Such properties change dynamically during operation, affecting significantly power transfer and communication

performance. Both these effects are related to an impedance mismatch which arises due to a varying coupling factor [28].

A RFID antenna with the typical sizes has a impedance that is rather low and a resonance frequency which is higher than 13,56 MHz. Therefore, antenna matching and tuning are required [20]. The better the matching, the less power is reflected on the connection between the IC bumps and the label antenna pads. An HF RFID IC is an ultra low power design, therefore matching is essential in order to make good sensitivity of the IC result in excellent read ranges in an end application [27].

The two-component network, also known as L-type due to the element arrangement, is used to transform the load impedance (Z_{load}) to the desired input impedance (Z_{in}). The components are alternatively connected in series and shunt configuration, as shown in Figure 3.7, which depicts eight possible arrangements of the capacitors and inductors [8].

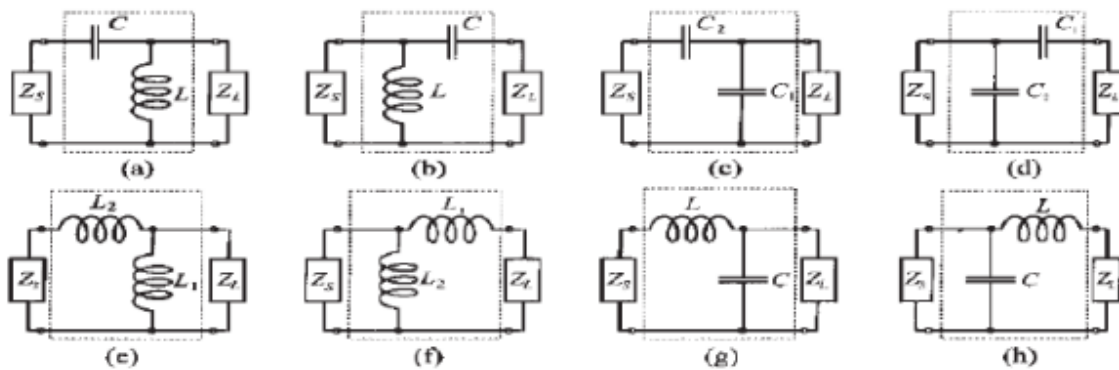

Figure 3.7. Eight possible configurations of the two-component matching networks.

The antenna has to be matched to 50 Ohm and has to be tuned to radiate with a quality factor of 35. Therefore, the load at 13.56 MHz should match the 50 ohm driver impedance R_{match} . The capacitances are used to match the inductive load and to build a resonator [26, 28]. A serial capacitor C_1 and a parallel capacitor C_2 is used as a matching network according to Figure 3.8 [21].

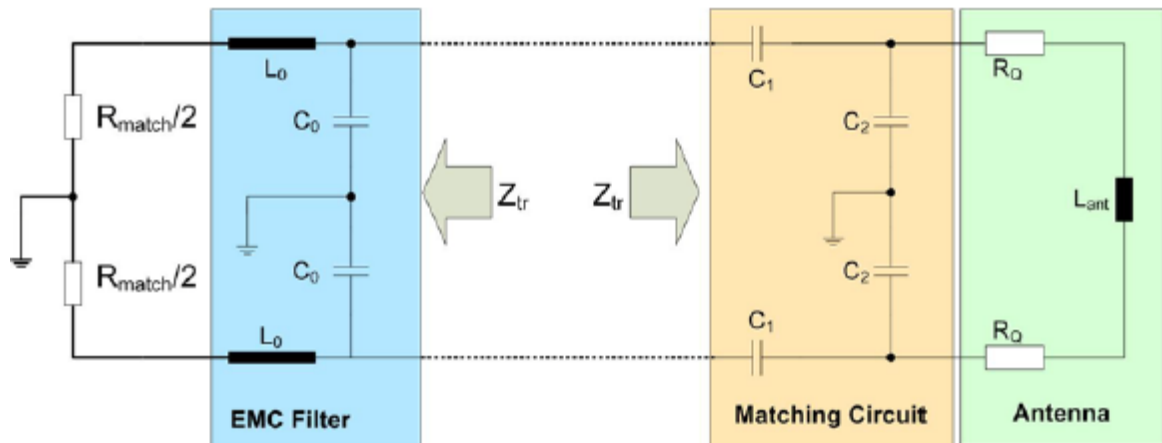

Figure 3.8. Definition of transformation impedance (Z_{tr}).

EMC filter and matching circuit must transform the antenna impedance to the required TX matching resistance $Z_{match(13.56MHz)}$. The following equations are needed to calculate the matching components [22].

$$Z_{tr} = R_{tr} + jX_{tr} \quad (3.10)$$

where,

$$R_{tr} = \frac{R_{match}}{(1 - \omega^2 \cdot L_0 \cdot C_0)^2 + (\omega \cdot C_0 \cdot \frac{R_{match}}{2})^2} = 216.7\Omega \quad (3.11)$$

$$X_{tr} = 2 \cdot \omega \cdot \frac{(1 - \omega^2 \cdot L_0 \cdot C_0)^2 \cdot L_0 - (\frac{R_{match}}{4})^2 \cdot C_0}{(1 - \omega^2 \cdot L_0 \cdot C_0)^2 + (\omega \cdot C_0 \cdot \frac{R_{match}}{2})^2} = -57.83\Omega \quad (3.12)$$

Series and parallel capacitances can be calculated as following equations:

$$C_1 = \frac{1}{\omega \left(\sqrt{\frac{R_{tr} \cdot R_{pa}}{4}} + \frac{X_{tr}}{4} \right)} = 16.02pF \quad (3.13)$$

$$C_2 = \frac{1}{\omega^2 \cdot \frac{L_a}{2}} - \frac{1}{\omega(\sqrt{\frac{R_{tr} \cdot R_{pa}}{4}})} = 45.2pF \quad (3.14)$$

3.5. Receiver Part Design

The resistor R_1 in combination with R_2 in the receiving part as shown in Figure 3.1 is a voltage divider which regulates the voltage level at the RX pin. The voltage level should not exceed $3 V_{pp}$, but should be maximized for optimum R/W performance. The measurement of the voltage level at the RX pin needs to be done with a low capacitance probe. Furthermore, those measurements needs to be done in the final housing/position as well as with different loads (targets) which detune the antenna and affects the RX signaling [22].

The receiver's components are defined by the experimental results. Maximum write distance is obtained where voltage at RX pin is 2.8V with components;

$$C_{RX} = 1nF \text{ (DC blocking capacitor),}$$

$$C_{vmid} = 100nF \text{ (decoupling capacitance),}$$

$$R_1 = 1k\Omega \text{ (voltage divider part),}$$

$$R_2 = 2.7k\Omega \text{ (voltage divider part).}$$

3.6. Layout Considerations

Usually highly efficient RF outputs generate a great number of harmonics, which have to be suppressed sufficiently to meet government restrictions. Due to the limited Q factor and some parasitic effects of the passive components, the antenna circuitry might resonate at some frequencies above 100 MHz, or behave like a second unwanted antenna at a certain frequency above 13.56 MHz. This has to be checked very carefully

during the design.

The most critical part of the antenna circuit is the EMC low pass filter, so the component area of this filter is placed as small as possible, and a proper ground connection of this filter is directly connected to the TVSS pin as described in Section 2.4.5.

3.7. Simulation Results

ADS simulation results with the antenna and all of the calculated components is shown in Figure 3.9

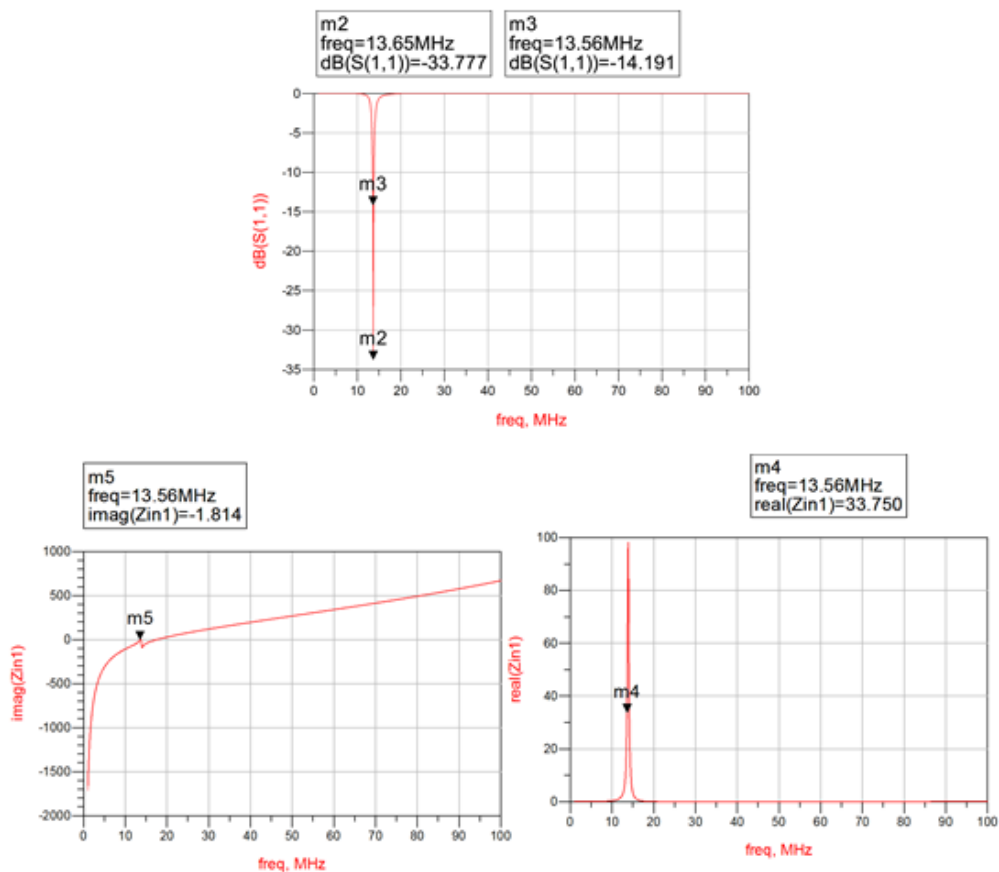

Figure 3.9. ADS simulation results of the design with all of calculated components.

ADS simulation results show that $S_{11} = -14.2$ dB at the frequency of 13.56 MHz. It is seen that the desired carrier frequency ($f_0 = 13.56$ MHz) is not obtained using the

calculated component values. It is expected because calculated values are based on simplified equations and equivalent circuit values can not be determined with 100% accuracy. Therefore, fine tuning of the matching circuit is necessary.

3.7.1. Tuning and Optimization

C_1 can mainly be used to tune the antenna along a circle of constant real part impedance in the Smith Chart. An increase of the serial capacitor means an increase of the reactive impedance (into the upper, inductive half plane). C_2 contributes to the reactive and the resistive component, so the adjustable parallel capacitor usually is used to match the antenna input impedance to a real part close to 50 Ohms [22]. The optimized values of matching components C_1 and C_2 are calculated by tuning tuning simulations in ADS. Best results are obtained where $C_1 = 46$ pF and $C_2 = 16$ pF. The ADS simulation results with optimized values of C_1 and C_2 are shown in Figure 3.10 below.

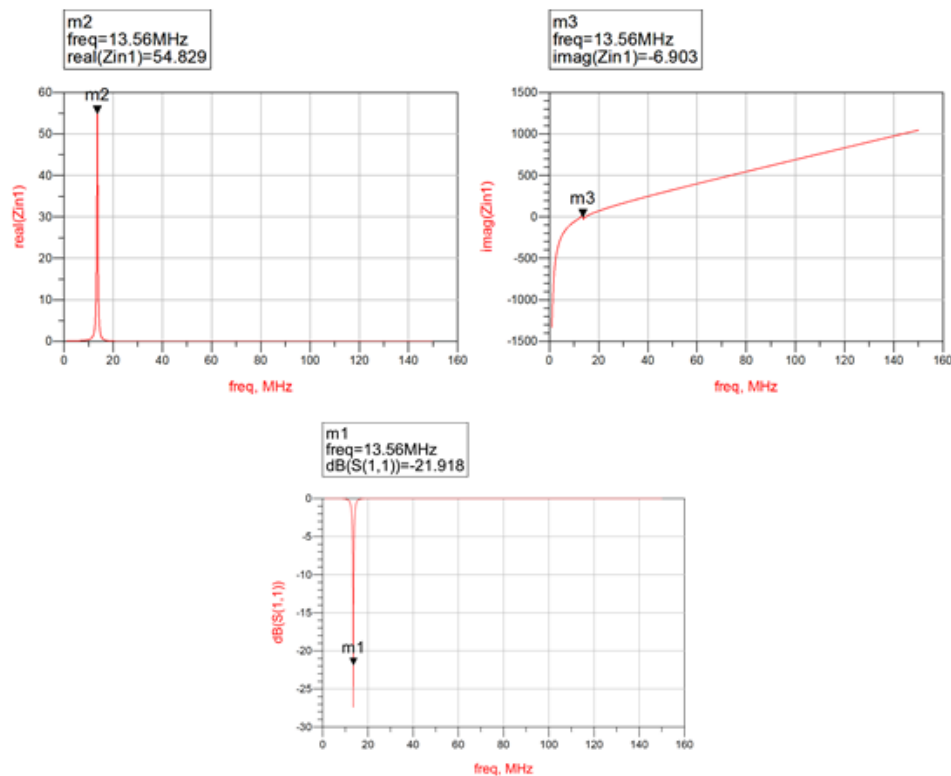

Figure 3.10. Simulation results using optimized values of matching components.

The results show that a good resonance behaviour is achieved at a frequency of 13.56 MHz. The most power is sent by the antenna when the input impedance is matched to 50Ω and the reactance is 0Ω at the resonance frequency. Optimal power transfer takes place when the line goes through the middle of the chart at a frequency of 13.56 MHz. From the simulation results, input impedance is 54.83Ω with a reactance of -6.9Ω . Return loss result at 13.56MHz is obtained as -21.92dB .

3.8. Measurements and Experimental Results

Antenna parameters are measured in Rodhe&Schwarz ZVB4 Vector network analyzer. The measurement result of the input impedance of the antenna at 1 MHz from 5 MHz is shown in Figure 3.11.

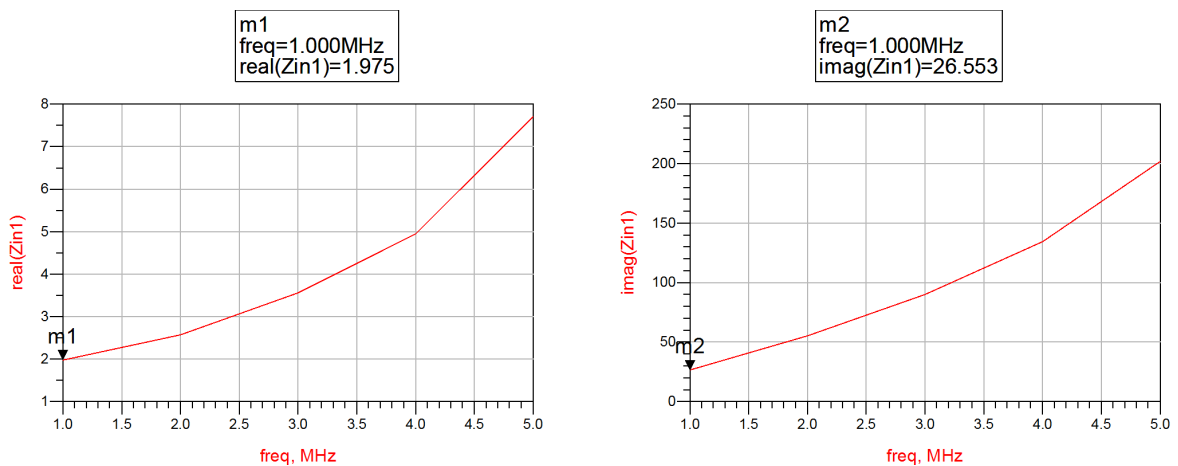

Figure 3.11. Antenna input impedance measurements (1-5 MHz).

The antenna inductance L_a and series resistance R_s can be calculated from Equation 3.1 and Equation 3.2;

$$R_s = 1.98 \text{ ohm and } L_a = 4.23\mu\text{H.}$$

Self resonance frequency (f_{res}) of the antenna is measured as 54 MHz and parallel resistance of antenna at self resonance frequency is measured (R_p) as 8.5 k Ω .

R_Q is calculated from Equation 3.8 as 3.1Ω and R_Q is selected 3.3Ω . ;

As defined in Section 3.3, L_0 is chosen 560 nH and C_0 is chosen 220 pF.

Using Equation 3.3, Equation 3.11, Equation 3.12, Equation 3.5, Equation 3.13, and Equation 3.14 with measured antenna series and parallel equivalent parameters;

$C_1 = 15.95$ pF (selected as 18 pF).

$C_2 = 45.68$ pF (selected as 47 pF).

Antenna and reader circuit is built with defined parameters. Values of all components in design are shown in Table 3.3 and built prototype is shown in Figure 3.12.

Table 3.3. Bill of Materials of the design using calculated components.

Component	Value	Component	Component
L_0	560 nH	R_1	1 k Ω
C_0	220 pF	R_2	2.7 k Ω
C_1	18 pF	C_{vmid}	100 nF
C_2	47 pF	C_{RX}	100 nF
R_Q	3.3 Ω		



Figure 3.12. Built prototype.

A SMA connector is connected to TX1 and TX2 inputs of PN531 transmission

module to measure the return loss and real and imaginary impedance of the design. Measurement setup used is shown in Figure 3.13 and measurement results are shown in Figure 3.14.



Figure 3.13. Measurement setup.

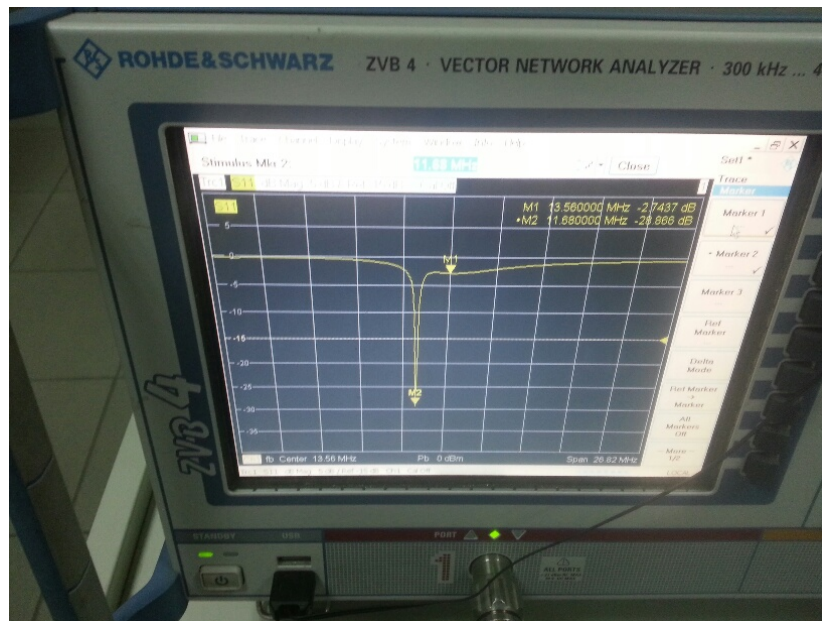

Figure 3.14. Experimental return loss measurements of the design.

Measured results show that operation frequency is shifted down to 11.68 MHz and optimization is required to obtain desired results.

3.9. Optimized Results

In order to obtain intended return loss in operation frequency, C_1 and C_2 values are tuned as described in Section 3.7.1.

Best return loss is obtained as where, $C_1 = 15$ pF and $C_2 = 33.8$ pF.

Measurement results with optimized values of C_1 and C_2 are shown in Figure 3.15 and 3.16.

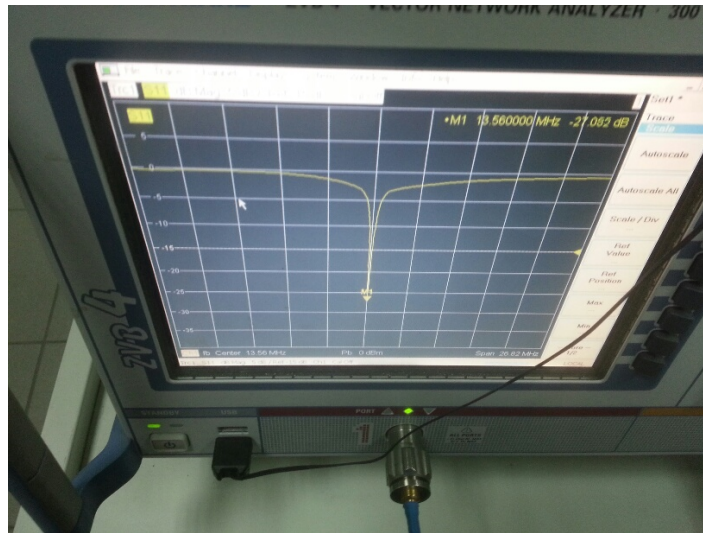

Figure 3.15. Experimental return loss measurements with optimized design.

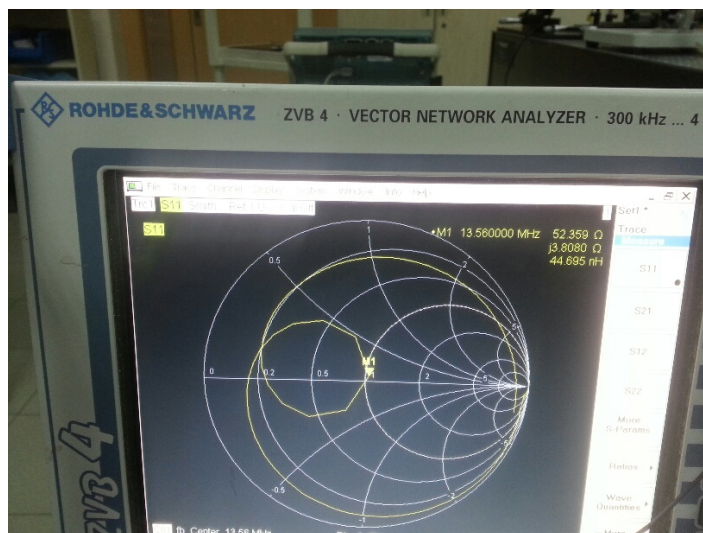

Figure 3.16. Smith Chart measurements with optimized design.

From measurement results, input impedance is obtained as 52.36Ω with reactance

of 3.8Ω . Return loss value at 13.56MHz is obtained as -27 dB. Measurement results show that a desired resonance behaviour and return loss value are achieved at frequency of 13.56 MHz.

3.10. Read Range Measurements

Read distance is measured with TV unit system. A special software is loaded in a TV system which prevents to use any menus in TV without passive tag is read by reader circuit.

When TV is opened, "READ RFID CARD" is written on TV screen. If card is read, "RFID CARD IS READ" is written on screen and user can use menus on TV. If accurate communication is not achieved, "RFID CARD ISN'T READ" is written on screen and system prevents user to use menus unless successful reading is achieved. Measurement setup for measuring the read range is shown in Figure 3.17.

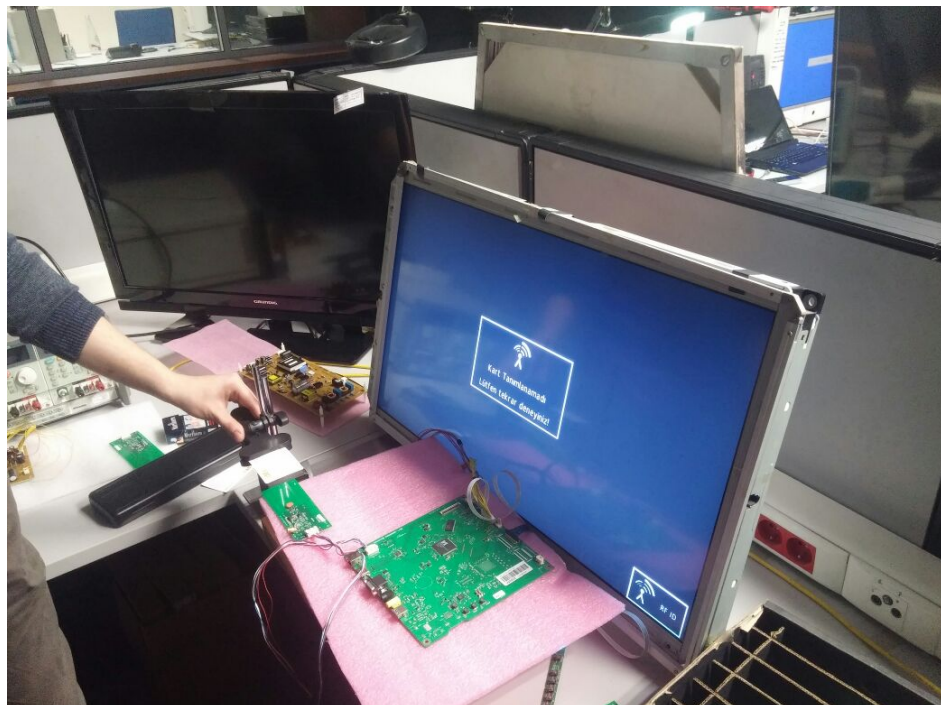

Figure 3.17. Measurement setup for range measurement.

Successful reading is achieved from distance of 4.6 cm with the components of values in Table 3.4 as seen in Figure 3.18.



Figure 3.18. Maximum read range measurements of the optimized reader design.

Table 3.4. Bill of Materials of the optimized design.

Component	Value	Component	Component
L_0	560 nH	R_1	1 k Ω
C_0	220 pF	R_2	2.7 k Ω
C_1	15 pF	C_{vmid}	100 nF
C_2	33.8 pF	C_{RX}	100 nF
R_Q	3.3 Ω		

3.11. Smart Card Effect

When passive smart cards place in proximity to the antenna of the reader, reader antenna performance is detuned due to the capacitive effect. Therefore, resonant frequency of the loop antenna is shifted downwards and the field intensity is reduced at operation frequency of 13.56 MHz. In the inductive coupled systems, the magnetic field strength decays with $1/r^3$ as stated in Equation 2.10. When the reader and the tag are close in proximity, magnetic field strength will increase. But if this increase will not compensate the reduction in field strength because of the card effect, communication will fail in proximity distance even if the design can achieve communication at higher distance. For this reason, smart card is placed in a fixed position away 3 cm from the reader antenna and matching components are detuned to achieve resonance at 13.56 MHz frequency.

Best results are obtained where,

$$C_1 = 18 \text{ pF},$$

$$C_2 = 53.8 \text{ pF}.$$

Measurement setup for measuring card effect is shown in Figure 3.19 and return loss results of the design using the detuned values of matching components are shown in Figure 3.20.



Figure 3.19. Measurement setup for measuring smart card effect.

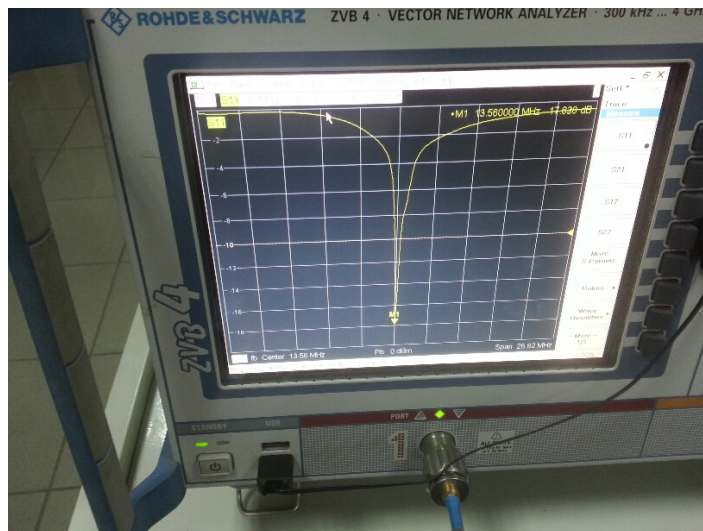

Figure 3.20. Return loss measurements using the detuned values of matching components.

Measurement results show that about -17 dB return loss value is obtained at 13.56 MHz. With detuned values of components, maximum read range is achieved as 3.6 cm which is less than previous measurements in Section 3.9, but accuracy of system is improved because losses in very proximity range (lower than 3 cm) drop. For measuring system accuracy, passive card is read in x, y, and z coordinates from 3 cm distance at 100 times and no misreading is observed.

4. CONCLUSION

In this thesis, we have explained a design methodology of a complete RFID reader module for high frequency near field applications. Devices with near field communication capability with proper RFID reader offer communication with passive smart cards generally up to 10 cm and the trend in the near field communication is to provide low cost customize applications up to 5-6 cm communication distance with a high accuracy. Therefore, most of the commercial RFID reader sellers competes with offering very low misreadings or wrong readings in determined communication distance even in harsh environments.

The aim of this thesis is to realize a 13.56 MHz RFID reader and antenna that placed in a TV unit and prevents undefined users to reach particular menus on TV. At the end of the thesis, two designs are realized in order to achieve maximum read range in one design and maximum accuracy up to 3 cm communication distance in another design. Performance of both designs have generally met our expectations. In future, this work will be expanded with improving software to provide controlling other electronic devices such as DVD player, computer, gaming consoles etc. and system can allow only defined user that equipped with smart card to watch broadcast, listen music or play games etc. Also, system performance comparison for different antenna types and different geometries and improving system accuracy at higher read range are planned as a future work.

REFERENCES

1. Finkenzeller, K., *RFID Handbook: Fundamentals and Applications in Contactless Smart Cards, Radio Frequency Identification and Near-Field Communication*, John Wiley, Los Angeles, USA, 2010.
2. Agilent, “Using a Network and Impedance Analyzer to Evaluate 13.56 MHz RFID Tags and Readers/Writers Application Note”, <http://cp.literature.agilent.com/litweb/pdf/5991-1475EN.pdf>, 2012, [Accessed January 2015].
3. Gossar, M., M. Stark, M. Gebhart, W. Pribyl and P. Soser, “Investigations to Achieve Very High Data Rates for Proximity Coupling Devices at 13.56 MHz and NFC Applications”, *2011 3rd International Workshop on, Near Field Communication (NFC)*, pp. 71–76, 2011.
4. Harle, R., “Topical Issues: RFID”, http://www.cl.cam.ac.uk/teaching/1112/TopIssues/Files/TI_L3_RFID.pdf, 2014, [Accessed January 2015].
5. Microchip, “MicroID 13.56 MHz RFID System Design Guide”, <http://ww1.microchip.com/downloads/en/DeviceDoc/21299E.pdf>, 2004, [Accessed January 2015].
6. Poole, I., “RFID Radio Frequency Identification Technology Tutorial”, <http://www.radio-electronics.com/info/wireless/radio-frequency-identification-rfid/technology-tutorial-basics.php>, 2014, [Accessed January 2015].
7. Weis, A. S., “RFID (Radio Frequency Identification): Principles and Applications”, <http://www.eecs.harvard.edu/cs199r/readings/rfid-article.pdf>, 2008, [Accessed February 2015].
8. Liu, W. and L. L. Wong, *3D RFID Simulation and Design - Factory Automation*,

- InTech, 2010.
9. Microchip, “Antenna Circuit Design for RFID Applications”, <http://ww1.microchip.com/downloads/en/AppNotes/00710c.pdf>, 2003, [Accessed January 2015].
 10. Zhang, H. and X. Lv, “Antenna Circuit Design and Simulation for the Reader of 125 KHz RFID”, *2012 International Conference on, Computer Science Service System (CSSS)*, pp. 507–510, 2012.
 11. Atmel, “Atmel Tag Tuning/RFID, Application Note”, <http://www.atmel.com/Images/DOC2055.PDF>, 2002, [Accessed February 2015].
 12. Rao, N. P. L. S. R., K.V.S., “Antenna Design for UHF RFID Tags: A Review and a Practical Application”, *IEEE Transactions on, Antennas and Propagation*, Vol. 53, No. 12, pp. 3870–3876, 2005.
 13. Mayordomo, I., R. Berenguer, A. Garcia-Alonso, I. Fernandez and I. Gutierrez, “Design and Implementation of a Long-Range RFID Reader for Passive Transponders”, *IEEE Transactions on, Microwave Theory and Techniques*, Vol. 57, No. 5, pp. 1283–1290, 2009.
 14. ISO 14443, *Identification Cards Contactless Integrated Circuit(s) Cards Proximity cards*, International Organization for Standardization, Geneva, Switzerland, 2000.
 15. ISO 15693, *Identification Cards Contactless Integrated Circuit(s) Cards Proximity Cards*, International Organization for Standardization, Geneva, Switzerland, 2003.
 16. ENTSI, “EN 300 330-1 (V1.3.1): Electromagnetic Compatibility and Radio Spectrum Matters (ERM); Short Range Devices (SRD); Radio Equipment in the Frequency Range 9 KHz to 25 MHz and Inductive Loop Systems in the Frequency Range 9 kHz to 30 MHz”,

- http://www.etsi.org/deliver/ets_en/300300_300399/30033002/01.01.0130/en_30033002v010101v.pdf, 2001, [Accessed January 2015].
17. ECC, “ERC70-03: Relating to the Use of Short Range Devices”, <http://www.erodocdb.dk/Docs/doc98/official/pdf/Rec7003e.PDF>, 2014, [Accessed January 2015].
 18. NXP, “Near Field Communication PN531- uC Based Transmission Module”, <http://www.nxp.com/documents/data-sheet/100020.pdf>, 2006, [Accessed January 2015].
 19. Zhang, M. T., Y. C. Jiao, F. S. Zhang and W. Wang, *Design of Antennas for RFID Application, Development and Implementation of RFID Technology*, InTech, 2009.
 20. Schroder, J. and S. Chang, “RFID and NFC antenna design, Part II”, [http://www.cartes-asia.com/content/download/128139/1408624/file/Schroeder-RFID and NFC antenna design_CartesAsia.pdf](http://www.cartes-asia.com/content/download/128139/1408624/file/Schroeder-RFID%20and%20NFC%20antenna%20design_CartesAsia.pdf), 2014, [Accessed January 2015].
 21. NXP, “Antenna Design Guide for MFRC52x, PN51x and PN53xs”, <http://eng.utah.edu/~mlewis/ref/NFC/AN1445.pdf>, 2010, [Accessed January 2015].
 22. NXP, “RF Amplifier for NXP Contactless NFC Reader ICs”, http://www.nxp.com/documents/application_note/AN142522.pdf, 2011, [Accessed January 2015].
 23. Lee, Y., “RFID Coil Design”, <http://ww1.microchip.com/downloads/en/AppNotes/00710c.pdf>, 2002, [Accessed January 2015].
 24. Qing, X. and Z. N. Chen, “Proximity Effects of Metallic Environments on High Frequency RFID Reader Antenna: Study and Applications”, *IEEE Transactions on, Antennas and Propagation*, Vol. 55, No. 11, pp. 3105–3111, 2007.
 25. jin Wang, H., G. Wang and Y. Shu, “Design of RFID Reader Using Multi-Antenna

- with Difference Spatial Location”, *International Conference on, Wireless Communications, Networking and Mobile Computing, 2007. WiCom 2007.*, pp. 2070–2073, 2007.
26. Gebhart, M., S. Birnstingl, J. Bruckbauer and E. Merlin, “Properties of a Test Bench to Verify Standard Compliance of Proximity Transponders”, *6th International Symposium on, Communication Systems, Networks and Digital Signal Processing, 2008. CNSDSP 2008.*, pp. 306–310, 2008.
27. NXP, “AN 1629 UHF RFID Label Antenna Design”, http://www.nxp.com/documents/application_note/AN162910.pdf, 2008, [Accessed February 2015].
28. Schober, A., M. Ciacci and M. Gebhart, “An NFC Air Interface Coupling Model for Contactless System Performance Estimation”, *2013 12th International Conference on, Telecommunications (ConTEL)*, pp. 243–250, 2013.