

**A DEVICE FOR FUNCTIONAL AND COSMETIC
IMPROVEMENT OF LAGOPHTALMOS DUE TO FACIAL
PARALYSIS**

by

MEHMET DOĞAN AŞIK

BS, Molecular Biology and Genetics, Istanbul Technical University, 2007

Submitted to the Institute of Biomedical Engineering
in partial fulfillment of the requirements
for the degree of
Master of Science
in
Biomedical Engineering

Boğaziçi University

July 2009

ACKNOWLEDGMENTS

First, I would like to thank Asst. Prof. Burak GÜÇLÜ for his advice and guidance for my thesis and my life.

Many thanks also go to Deniz NEVŞEHİRLİ and Mustafa Zahid YILDIZ for helping me in the lab.

My thanks also go to all my friends who never left me alone when I was in trouble with many problems

Special thanks to Duygu TORUN for her extraordinary friendship.

Thanks to my parents for financial and psychological support.

And finally never enough thanks to Dr. Daniel Aaron PRESS for his brotherhood.

ABSTRACT

A DEVICE FOR FUNCTIONAL AND COSMETIC IMPROVEMENT OF LAGOPHTALMOS DUE TO FACIAL PARALYSIS

A new device for the correction of eyelid problems due to facial palsy was studied. Lagophthalmos is the condition of the paralyzed eyelids' to close totally. It may cause drying and irritation .In this thesis, 14 rabbits were injected with local anaesthetics to induce temporary facial palsy and lagophthalmos. In order to provide functionality to the upper eyelids, ferromagnetic steel pieces were placed inside and outside of the eyelids of the rabbits. The device moves the eyelids by magnetically pulling the steel pieces. The control group (n=5) did not wear the device.The treatment group with external implant (n=4) and the treatment group with internal implant (n=5) made to wear device and tested. All animals were observed during the experiments and recorded to video tapes. The data collected from video records were analyzed to test the statistical difference between control and the treated groups. The results showed that treatment groups paralyzed eye and control groups paralyzed eye have significant differences. Furthermore, the treatment group with internal implant shows a noticeable similarity with the healthy(un-paralyzed) eye.

Keywords: Lagophthalmos, Facial Palsy, Implant, Medical Device, Rabbit.

ÖZET

YÜZ FELCİNE BAĞLI GELİŞEN LAGOPHTALMOS'UN İŞLEVSEL VE KOZMETİK OLARAK DÜZELTİLMESİNDE YENİ BİR CİHAZ

Bu araştırmada, yüz felcine bağlı göz kapağı problemlerinin düzeltilmesi için geliştirilen yeni bir cihaz ve bu cihazın teknik kullanımı sunulmuştur. Felçli taraftaki üst göz kapağının tamamen kapanamaması gözde kuruma ve rahatsızlıklara sebep olur ve Lagoftalmus olarak adlandırılır. Bu tez çalışmasında 14 tavşana, geçici yüz felci oluşturmak için lokal anestezi yapılmıştır. Göz kapaklarına tekrar işlevsellik kazandırmak için 4 tavşanın göz kapaklarının dışına, 5 tavşanında göz kapaklarının içine ferromagnetik çelik implantlar yerleştirilmiştir ve bu implantlar üzerinde cihazla oluşturulan manyetik kuvvet, göz kapağının kapanmasını sağlamıştır. Kontrol grubunu oluşturan diğer 5 tavşana ise cihaz bağlanmamıştır. Tüm denekler deney süresi boyunca gözlemlenmiş ve videoya kaydedilmiştir. Cihazı giyen hayvanlar ve kontrol grupları istatistiksel olarak karşılaştırılmıştır. Sonuçlar tedavi grubu hayvanlarının felçli gözü ve kontrol hayvanlarının felçli gözü arasında büyük bir fark olduğunu göstermiştir. Ayrıca, göz kapağının içine implant yerleştirilmiş tedavi grubu, sağlıklı (felç olmayan) gözle farkedilir bir benzerlik göstermiştir.

Anahtar Sözcükler: Lagoftalmus, Yüz felci, İmplant, Tıbbi Cihaz, Tavşan.

TABLE OF CONTENTS

ACKNOWLEDGMENTS	iii
ABSTRACT	iv
ÖZET	v
LIST OF FIGURES	viii
LIST OF TABLES	xi
LIST OF SYMBOLS	xiii
LIST OF ABBREVIATIONS	xiv
1. INTRODUCTION	1
1.1 Facial Palsy	1
1.2 Lagophthalmos	2
1.2.1 Aesthetics	2
1.2.2 Functionality of the Lid and Vision	3
1.3 Surgical Treatments for Lagophthalmos	3
1.4 Electro-Magnetism and Its Medical Use	4
2. METHOD	8
2.1 Device	8
2.1.1 Video Recording And Data acquisition	10
2.2 Device Development and Calibration	10
2.2.1 Development of the Device	11
2.2.1.1 Power Supply	11
2.2.1.2 Re-design of the Frame	11
2.2.2 Electromagnetic Calibrations	12
2.2.2.1 Current Calibration	12
2.2.2.2 Magnetism Calibration	12
2.3 Surgery	13
2.4 Experiments	16
2.4.1 Control Group	16
2.4.2 Internal Implant Group	16
2.4.3 External Implant Group	17

2.5	Data Analysis	17
3.	RESULTS	19
3.1	Calibration Results	19
3.1.1	Current Measurements on the Actuator	19
3.1.2	Magnetic Flux Density Produced by the Device	20
3.2	Experimental Results	20
3.2.1	A Sample Subject	20
3.2.2	Control Group's Healthy and Paralyzed Eyes	21
3.2.3	Control Group's and Treatment Groups' Paralyzed Eyes	23
3.2.4	Healthy and Paralyzed Eyes of Treatment Group with External Implant	24
3.2.5	Healthy and Paralyzed Eyes of Treatment Group with Internal Implant	25
4.	DISCUSSION	27
	APPENDIX A.	30
	REFERENCES	38

LIST OF FIGURES

Figure 1.1	Magnetic field on axis of solenoid[18].	4
Figure 2.1	Block diagram of the device	8
Figure 2.2	A sample comparator circuit with a hysteresis. In this thesis the reference voltage input(V_{REF}) was determined with the potentiometer on the device by user . The other input voltage V_{IN} produced by physical factor(infrared light) that was sensed by the detector.	9
Figure 2.3	A:The threshold-infrared light comparison. B:output voltage of the comparator.	9
Figure 2.4	Experimental Setup	10
Figure 2.5	Previous frame and the present frame	11
Figure 2.6	Adjustable parts of the present frame are shown by the arrows	12
Figure 2.7	Determination of the incision site on the rabbit.	14
Figure 2.8	The incision area and the pocket prepared for the implant placement	14
Figure 2.9	Placement of the metal implant into eyelid	15
Figure 2.10	Closure of the lid with the sutures	15
Figure 2.11	Control group experiments	16
Figure 2.12	Treatment groups experiments	17
Figure 2.13	Placement of the external implant	18
Figure 3.1	Current calibration results	19
Figure 3.2	Magnetism calibration results	20
Figure 3.3	A sample experimental data for the treatment group with internal implant. A : The positions before and during the flash in the paralyzed eyelid during a set of experiment. B : the mean values of the positions before and during the flash are shown.	21

- Figure 3.4 Control group's the paralyzed eyelids' and healthy eyelids' positions before and during the flash. The paralyzed eyelids' positions before and during the flash are not significantly different. However, the healthy and paralyzed eyelids' positions before the flash ($p=0.008$) and the positions of the healthy eye before and during the flash are significantly different ($p=0.008$). 22
- Figure 3.5 Control group. **A:** Paralyzed eye before the flash **B:** Paralyzed eye during the flash **C:** Healthy eye before the flash **D:** Healthy eye before the flash. Red bars equal to 1cm. 22
- Figure 3.6 Control group and treatment groups paralyzed eyelids' position before and during the flashes. The positions of the eyelids before the flash in the control group and in the treatment group with external implants are similar(ns),but the treatment group with internal implants are significantly different from the control group($p=0.031$). The eyelid positions during the flash in both treatment groups are not significantly different. The eyelid positions during the flash in the treatment group with external implant is significantly different from the position of the eyelids during the flash in the control group ($p=0.008$). The eyelid positions during the flash in the treatment group with internal implant is significantly different from the position of the eyelids during the flash in the control group ($p=0.016$). 23
- Figure 3.7 Treatment group with external implant. **A:** Paralyzed eye before the flash **B:** Paralyzed eye during the flash **C:** Healthy eye before the flash **D:** Healthy eye before the flash. Red bars equal to 1cm. 24

- Figure 3.8 The comparison between the positions of the healthy and paralyzed eyelids in the treatment group with external implant. The treatment group's healthy eyelids' and paralyzed eyelids' position before the flash are not significantly different ($p=0.083$). The paralyzed eyelids' positions before and during the flash are significantly different ($p=0.008$). The healthy eyelids' position during the flash and the paralyzed eyelids' position during the flash is similar. The positions of the eyelids' before and during the flash are significantly different in both healthy and paralyzed eyes ($p=0.008$). 25
- Figure 3.9 The comparison between the positions of the healthy and paralyzed eyelids in the treatment group with internal implant. The treatment group's healthy eyelids' and paralyzed eyelids' position before the flash are similar. The paralyzed eyelids' positions before and during the flash are significantly different ($p=0.008$). The healthy eyelids' position during the flash and the paralyzed eyelids' position during the flash is similar. The positions of the eyelids' before and during the flash are significantly different in both healthy and paralyzed eyes ($p=0.008$). 26
- Figure 3.10 Treatment group with internal implant. **A:** Paralyzed eye before the flash **B:** Paralyzed eye during the flash **C:** Healthy eye before the flash **D:** Healthy eye before the flash. Red bars equal to 1cm. 26
- Figure 4.1 A problematic placement of internal implant **A:** Paralyzed eye before the flash **B:** Paralyzed eye during the flash. Red bar equals to 1cm. 28

LIST OF TABLES

Table 3.1	Mean values(mm), standard deviation and standard error of mean values of the open, the closed positions and the movement of the paralyzed eyelids' of the treatment group with internal implant.	21
Table A.1	Experimental data of healthy eye of treatment group with external implants	30
Table A.2	Experimental data of healthy eye of treatment group with internal implants	31
Table A.3	Experimental data of healthy eye of control group	32
Table A.4	Experimental data of paralyzed eye of treatment group with external implants	33
Table A.5	Experimental data of paralyzed eye of treatment group with internal implants	34
Table A.6	Experimental data of paralyzed eye of control group.	35
Table A.7	Mean values, standard deviation and standard error of mean values of the open, the closed positions and the movement of the paralyzed eyelids' of the treatment group with external implant.	36
Table A.8	Mean values, standard deviation and standard error of mean values of the open, the closed positions and the movement of the paralyzed eyelids' of the treatment group with internal implant.	36
Table A.9	Mean values, standard deviation and standard error of mean values of the open, the closed positions and the movement of the paralyzed eyelids' of control group.	36
Table A.10	Mean values, standard deviation and standard error of mean values of the open, the closed positions and the movement of the healthy eyelids' of the treatment group with external implant.	37
Table A.11	Mean values, standard deviation and standard error of mean values of the open, the closed positions and the movement of the healthy eyelids' of the treatment group with internal implant.	37

Table A.12	Mean values, standard deviation and standard error of mean values of the open, the closed positions and the movement of the healthy eyelids' of Control group	37
------------	---	----

LIST OF SYMBOLS

μ_0	The magnetic permeability of media
i	The current passing through the solenoid
a	The radius of the solenoid
x	The length of the solenoid
n	Turns around the solenoid
n	The division of the turns to length of the solenoid
A	The cross-sectional area of the solenoid
r	The gap between solenoid and metal
p_1	Magnetic moment strengt of the solenoid
p_2	Magnetic moment strength of the metal
H	Magnetic field strength
M	Magnetization
m	magnetic dipole
χ	Magnetic susceptibility
F	Force
V	Volume

LIST OF ABBREVIATIONS

LED	Light Emitting Diode
s	Second
FPS	Frame Per Second
A	Ampere
W	Watt
B	Magnetic Flux Density(mT)

1. INTRODUCTION

Facial paralysis is a common problem. Crumley and Hashisaki states "Idiopathic facial paralysis or Bell's palsy occurs at an approximate rate of 20 cases per 100,000 population per year" [1]. It appears without discriminating age or sex, 71% of the patients had a total recovery and 4% have persistent moderate facial palsy or associated mass facial movements [1]. Paralytic lagophthalmos generally occurs because of peripheral facial nerve lesions and a paralytic orbicularis [2]. Although surgical techniques that are based on reconstruction of the eyelid are useful, they also have several notable complications [2, 3, 4]. The aim of this study is test a novel device for preventing these complications and improvement of the function of eyelids.

1.1 Facial Palsy

Paralysis, or palsy of one side of the face can be classified into two main categories. The first is caused by a damage above the lower motor neuron, and the second which includes palsies induced by the lower motor neuron and its distal termination upon the facial musculature [5, 6]. Supranuclear palsies are easy to diagnose and mostly caused by protean[5]. However, Bell's palsy which is caused by lower motor neuron palsies, is one of the largest etiological group of facial palsies[1]. The entire face's voluntary or mimetic movement loss can be caused by damage of the lower motor neuron[5].

The etiology of the Bell's palsy was described in 1821 by Bell and overall impression was a possible viral infection with edema and secondary demyelination[5]. The successive studies gave us a better understanding about the etiology of this disease. Infections, trauma, metabolic disorders, tumors and some syndromes can be the originator of lower motor neuron facial palsies other than the Bell's Palsy[1, 5].

Treatments chosen for a successful therapy of Bell's palsy must be viewed against

the background of the disorder. Suggested therapies can be divided into two as general and specific therapies[7]:

1. General therapy
 - (a) Reassurance and discussion of the illness
 - (b) Care for the affected eye.
 - (c) Splinting, massage and exercises
 - (d) Electrical stimulation
2. Specific therapy
 - (a) Antihistamines and cervical sympathectomy
 - (b) Dehydrating agents
 - (c) Corticosteroids

1.2 Lagophthalmos

Paralytic lagophthalmos generally occurs because of peripheral facial nerve lesions and a paralytic orbicularis[3]. Although surgical techniques that are used for reconstruction of the eyelid are prevalent, they have several notable complications and poor results[3, 2, 4].

1.2.1 Aesthetics

Lagophthalmos and similar eye problems cause undesired appearance[5]. The earliest aesthetics operations of the upper lid were possibly done for functional reasons, but now, aesthetic reasons are becoming more important[8]. Total loss of mimics and lid movements, partial loss of them or asymmetry of the face are disturbing aesthetic results of the lagophthalms[9]

1.2.2 Functionality of the Lid and Vision

Blinking is rapid movement of the eyelid down and up. It is an essential function of the eye that helps cleaning of the cornea and conjunctiva with tear [3, 5]. Lack of blinking due to the facial paralysis causes irritation and dryness. A proper eyelid works as a barrier covering the eye against hazardous light and fumes, excessive moisture and dryness, foreign bodies, microorganisms and particulate matter[3]. Without this barrier, eye cannot protect itself. Vision can be affected by loss of functionality of the eyelid. Corneal damage which can cause blindness subsequently, can occur due to this loss[1, 2]

1.3 Surgical Treatments for Lagophthalmos

Eyelid reconstruction methods vary, but they stand on the same principles:

1. The missing parts should be replaced with similar tissue
2. Normal function, palpebral occlusion and corneal coverage should be restored
3. Function of the vision should be disturbed as minimal as it can be[10].

First, temporary tarsorrhaphy joins the upper and lower eyelid with suture[11]. This method protects eye from corneal exposure. However, It should not be preferred initially[10]. There are also Müller's muscle and levator aponeurosis surgeries for upper eyelid retraction. These procedures include Müllerectomy and recession of the levator aponeurosis, myotomy for levator aponeurosis and externalized, adjustable sutures for levator aponeurosis recession[11]. Levator muscle surgeries can be used for both lengthening and shortening of the eyelid[12].

Second, some implants are used for treating lagophthalmos. For example, a palpebral spring implant can be used for lagophthalmos therapy. Guy and Ranshoff [13] state "The spring is calibrated and fashioned so that, upon relaxation of the levator

palpebral superior muscle, it passively closes the upper eyelid yet allow the levator, which is innervated by the third cranial nerve, to overcome the power of the spring and open eye at will. It is constructed from stainless steel wire, 0.35 mm in diameter containing 18 percent chrome and 8 percent nickel. It has a good tissue tolerance and its fatigability is practically nil."

1.4 Electro-Magnetism and Its Medical Use

The name of the magnetism possibly comes from the large deposit of a magnetic oxide of iron in the ancient province of Magnesia[14]. However, the scientific definition of the electromagnetism and the electromagnetic theory were put forward by Ampère, Coulomb and finally Maxwell[14, 15].

A solenoid is a helical winding on a cylindrical surface or it could be described as n turns uniformly wound on a cylindrical form of radius a and length x [16, 17]. The Magnetic flux density produced by an solenoid can be calculated as in the following equations 1.1-1.3[18] which are derived from Ampère's law: Magnetic field due to

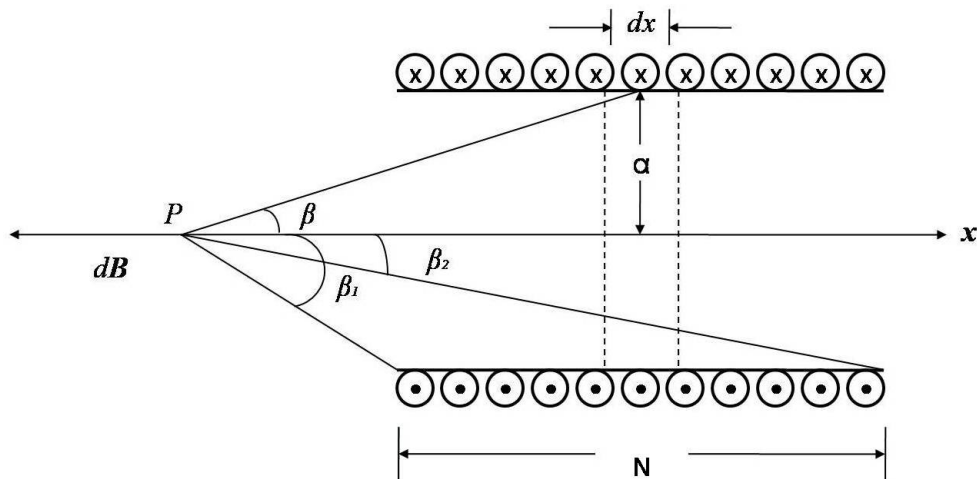

Figure 1.1 Magnetic field on axis of solenoid[18].

current in straight conductor can be formulated like 1.1

$$dB = \left(\frac{\mu_0}{4\pi}\right) \frac{idl \times r_1}{r^2} \quad (1.1)$$

According to that formula, fields of circular loop at an axial point can be calculated as in 1.2

$$dB = \frac{\mu_0 i dl}{4\pi r^2} \quad (1.2)$$

For calculating the magnetic field on axis of the solenoid 1.3 should be used:

$$B = \frac{\mu_0 ni}{x} \quad (1.3)$$

and for the pulling force produced by this B can be calculated by the help of following formula. The formula used for calculating the pulling force between two bar magnets is used for this purpose. A is the cross-sectional area and r is the gap between solenoid and metal and p_1 is magnetic moment strengt of the solenoid and p_2 is magnetic moment strength of the metal;(in cgs units)

$$F = \frac{p_1 p_2}{r^2} \quad (1.4)$$

H magnetic field strength in cgs units can be calculated as in 1.5.

$$H = \frac{ni}{x79.58} \quad (1.5)$$

Magnetization in cgs units can be calculated as in 1.6.

$$M = \frac{m}{V} \quad (1.6)$$

Magnetization and magnetic field strengt are propotional and the propotion is

equal to susceptibility χ .

$$M = H\chi \quad (1.7)$$

Magnetic moment of a bar magnet can be calculated with magnetic moment strength and the length of the bar magnet.

$$m = px \quad (1.8)$$

Magnetic field strength on a point whose distance to magnet is r can be calculated as in 1.9.

$$H = \frac{p_1}{r^2} \quad (1.9)$$

The final formula can be given as in 1.10.

$$F = \frac{(\chi_1 ni A_1)^2 \chi_2 A_2}{r^4 (x 79.58)^2} \quad (1.10)$$

For $i=4.1$ A, $n=100$, $x= 6$ cm $r= 1$ cm $\chi_1 = 0.001256(emu)/cm^3$ and $\chi_2 = 0.0007536(emu)/cm^3$ and $A_1 = 0.25cm^2$ $A_2 = 0.15cm^2$ values (sample values for the setup used in the thesis) the force produced can be calculated as 0.007 N which is approximately equal to 0.7 force grams by using these formula.

In recent years, there have been numerous studies on the interaction of electro-

magnetic radiation with biological systems, although the controversy about potential health hazards due to EM radiation are also mentioned[19]. Wide use of telecommunication devices arises the question of their safety for wearers of implanted medical devices, like pacemakers and hearing aids[20]. There are various models and devices due to application based on EM theory[19, 20]. The device uses magnetic flux density to make a mechanical movement without mechanical contact with the target tissue. The paralyzed eyelid with an implanted ferromagnetic steel piece artificially blinks by the help of the this device.

2. METHOD

2.1 Device

The device has two parts: frame and processing circuit(Figure 2.1). The frame part has an infrared emitter and a infrared detector. A additional infrared filter was placed on the detector. It was fixed on a 2x2.5 cm aluminum piece screwed to frame. The angle and position of this piece was adjustable. The infrared light beam is reflected by the cornea. When the eye is open, reflectional light intensity is higher than the intensity reflected of the closed eye. The detector collects the reflected beam and converts it to electrical current for signal processing.

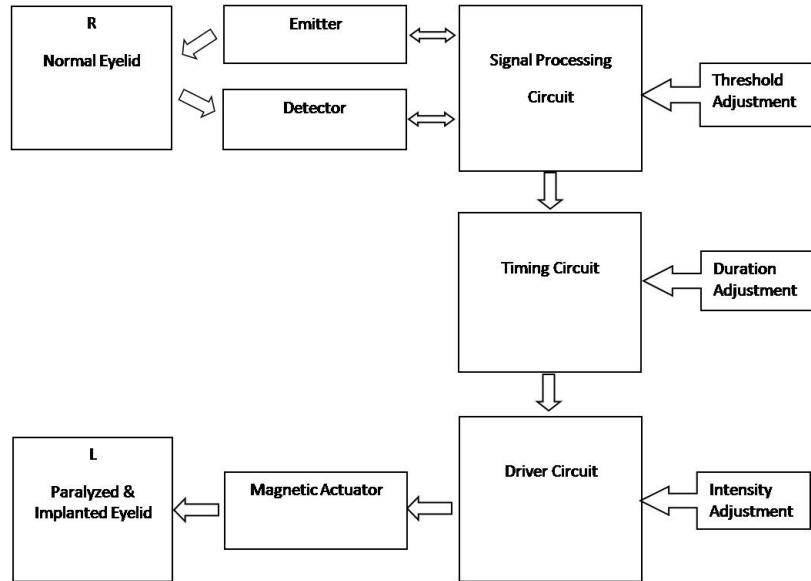

Figure 2.1 Block diagram of the device

The comparator unit of the circuit compares the user-defined threshold voltage and sensed voltage(**Figure 2.3**). The comparator gives a 5 V output voltage, if the sensed voltage($V_{IN}=V_-$) is smaller than the reference voltage($V_{REF}=V_+$)(**Figure 2.2**) or it gives a zero output. A hysteresis was added to the positive feedback of the comparator. The duration and the intensity parameters of the pulse are adjusted by the buttons on the device. The timing and driver circuits are responsible for this

process. Electro-magnetic actuator produces a magnetic field(magnetic flux density) with the current coming from the driver circuit. The position and the angle of the actuator to the eyelid can be adjusted with a screw connecting it to the frame. The magnetic flux density affects the ferromagnetic implant in or on the eyelid. The eyelid moves with this effect.

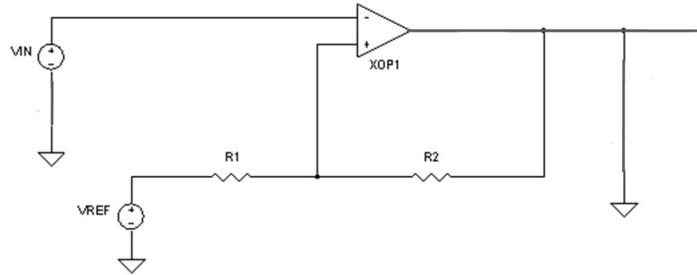
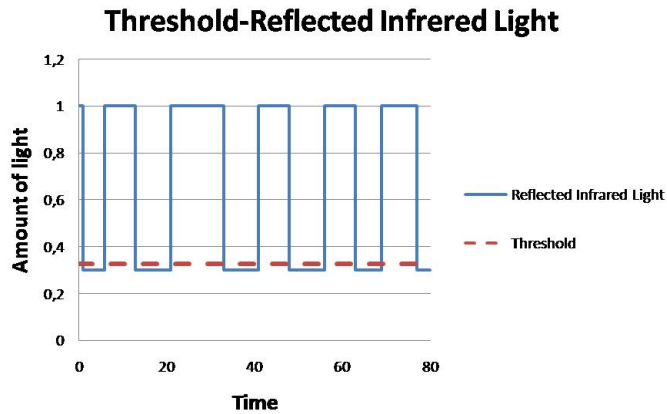

Figure 2.2 A sample comparator circuit with a hysteresis. In this thesis the reference voltage input (V_{REF}) was determined with the potentiometer on the device by user . The other input voltage V_{IN} produced by physical factor(infrared light) that was sensed by the detector.

A



B

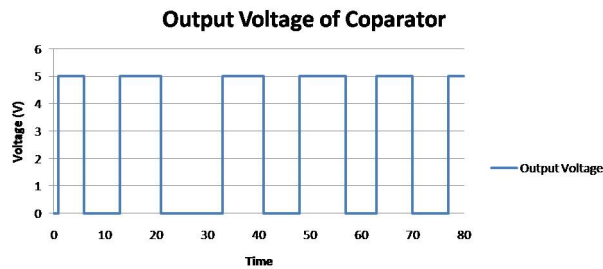

Figure 2.3 A:The threshold-infrared light comparison. B:output voltage of the comparator.

2.1.1 Video Recording And Data acquisition

Videos were recorded by two PC cameras(**Figure 2.4**) working simultaneously (PK-636MA, A4 TECH, California/USA) and captured with AMCap software(AMCAP-DirectShow video capture, Version 9.0) by USB. Videos were recorded in 640x480 resolution and at 30 FPS frame rate. Videos were edited with VEM software (Video Edit Master,Version 1.8) and snapshot images of the rabbits were taken as JPEGs. The positions before and during the flash in the healthy and paralyzed eyes' eyelids were classified. All JPEGs were visualized in Photoshop software (Adobe photoshop CS2,Version 9.0.2). Measurement tool of the software was used to make measurements on images. For the positions of the eyelids before and during the flash, distance between upper and lower eyelid was on measured on digital images.



Figure 2.4 Experimental Setup

2.2 Device Development and Calibration

The device was designed and produced by Asst. Prof. Burak Güçlü. The aim was to test the device on animals before clinical use further.

2.2.1 Development of the Device

Initially, the device was tested on a rabbit. It was unable to close the eyelid with the power from batteries. It was also affected by the day light. An additional infrared filter added to the receiver part of the device and a main power supply was built to obtain a higher currents for the actuator. The frame was also re-designed to have a better and flexible placement of the actuator, detector and emitter.

2.2.1.1 Power Supply. Power supply was designed to give 12 Volts and 5 A's DC. The output of the power source was measured to be 11.7 Volts and 5.1 A's. This power output was adequate for desired results. The initial portable design had four 9 V batteries connected parallel.

2.2.1.2 Re-design of the Frame. The initial frame design had fixed actuator and emitter-detector system on an aluminum piece which had eye openings on it. It was developed for a particular animal and not flexible for testing on other animals (**Figure 2.5**). Additionally, it partially blocked the vision of rabbits. The new frame fixed those problems. As can be seen in the **figure 2.6**, it was designed to be used with different sized animals by having screws to adjust the depth, width and angle of the different parts of the device.



Figure 2.5 Previous frame and the present frame

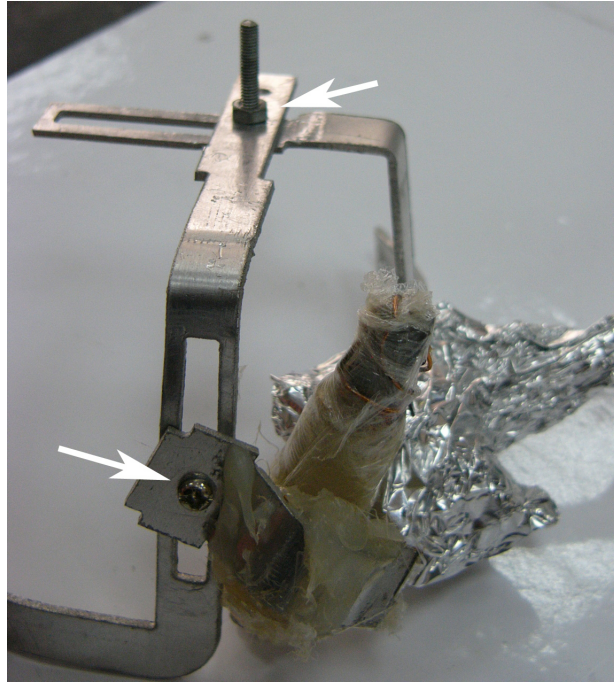

Figure 2.6 Adjustable parts of the present frame are shown by the arrows

2.2.2 Electromagnetic Calibrations

The current passing through the electromagnet and the magnetism produced by the magnet was measured for different settings of the device.

2.2.2.1 Current Calibration. For the current measurements, a 1 Ohm high voltage resistor was serially attached to the electromagnet. The electromagnet's internal resistance was small enough to be negligible. The oscilloscope showed the voltage on the resistor and the current passing through the electromagnet was calculated. For 5 intensity and duration adjustments, 25 different settings were tested.

2.2.2.2 Magnetism Calibration. A gaussmeter (B4080, F.W. Bell) was used for magnetism measurements (Istanbul Technical University, Physical Engineering Department). The probe of the gaussmeter was placed 1 cm away from the electromagnet. Both the electromagnet and probe were fixed in this position. Calibration was done in a zero chamber. For 5 duration and intensity adjustments, 25 different adjustments

were tested. Furthermore, 4 more measurements were done at different points of the laboratory and the mean of the values were calculated.

2.3 Surgery

The insertion of the implant was done under parenteral general anesthesia by Plastic Surgeon Dr. Erdem Güven(Ethical approval for the procedures used on animals was taken from Istanbul Universitesi Deneysel Tip Arastirma Enstitusu Deneysel Hayvanlari Etik Kurulu.). Initially, 5mg/kg xylazin and 35 mg/kg ketamin mixture was injected to rabbit intramuscularly. The anesthetic effect of the drug lasted 40-60 minutes.

The sites of the incision were marked with ink above the lid margin just medial to the midportion of the lid over the tarsal plate(**Figure 2.7**).The pretarsal skin was stretched superiorly with supratarsal fixation sutures.Limits of the incision were determined due to implants and targeted the midportion of the lid(**Figure 2.8**). Skin texture of the rabbit was very thin,so care was taken the incision could not pass through the eyelid.

After incision was made by scalpel, the upper skin incision was gathered gently between forceps and skin distracted from tissue with a straight scissors. The pocket prepared with skin distraction should not be too narrow or too wide for the implant. The metal implant weighed 0.275-0.285 gr weight and had a size of 0.6x15mm and it was placed into the eyelid as in the **figure 2.9** .After the placement of the implant, skin closure was completed by sutures(**Figure 2.10**). Animals were taken to experiments after the closure of the wound which occurred two or three weeks after the operation.

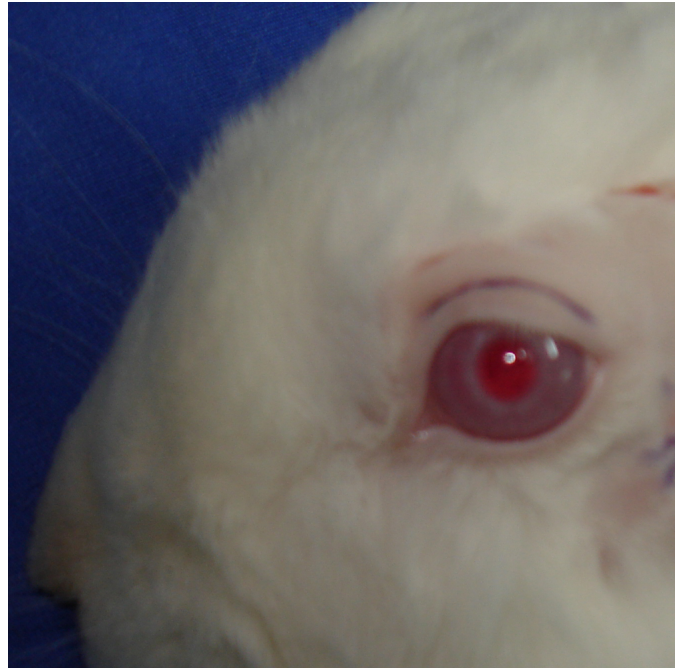

Figure 2.7 Determination of the incision site on the rabbit.



Figure 2.8 The incision area and the pocket prepared for the implant placement



Figure 2.9 Placement of the metal implant into eyelid

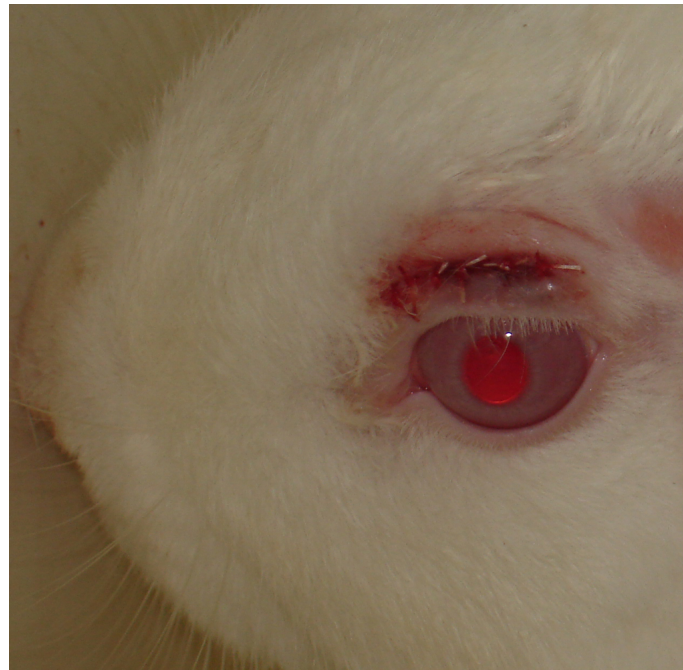

Figure 2.10 Closure of the lid with the sutures

2.4 Experiments

All animals were injected with 2 ml injectors to paralyze the left part of their faces. Injections targeted the temporal skin and the peripheral facial nerves to cause lagophthalmos. The solution injected was a mixture of local anesthetics which included 0.5/Kg %0.5 of bupivacain hydrochloride (Marcaine, AstraZeneca) and 0.5 ml/Kg %2 of prilocaine (Citanest, AstraZeneca).The effect of the drugs lasted for 30-40 minutes.

2.4.1 Control Group

Control animals were exposed to 1 W two white LED flashes of 1 s pulses. LED flashes caused a blink response in the healthy eye. Because the blink responses of the rabbit eyes are independent, LED's were placed at two sides of the head to see the difference between paralyzed and healthy eyes (**Figure 2.11**). 30 random light pulses were flashed to both eyes. Video Cameras recorded the eyelid movements during the session.

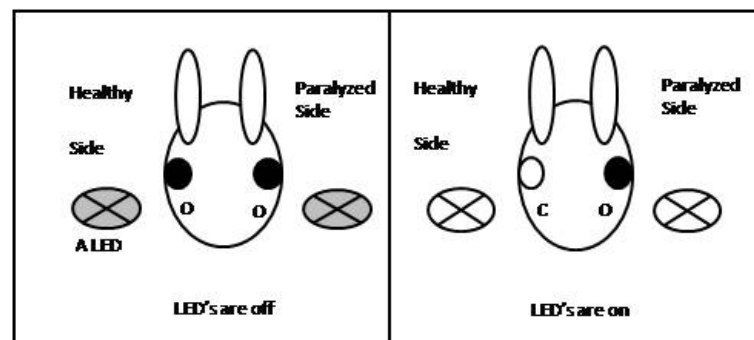

Figure 2.11 Control group experiments

2.4.2 Internal Implant Group

Treatment group with the internal implant was made to wear the frame. Device was calibrated according to the right (healthy) eye. A LED was placed to right side of the rabbit's head (**Figure 2.12**). LED flashes caused a blink response in the healthy

eye. The paralyzed side of the animal did not need a LED impulse to blink. The magnetic actuator caused the artificial blink in the paralyzed eye. 30 random light pulses were flashed to the healthy eye. Video cameras recorded the eyelid movements during the session.

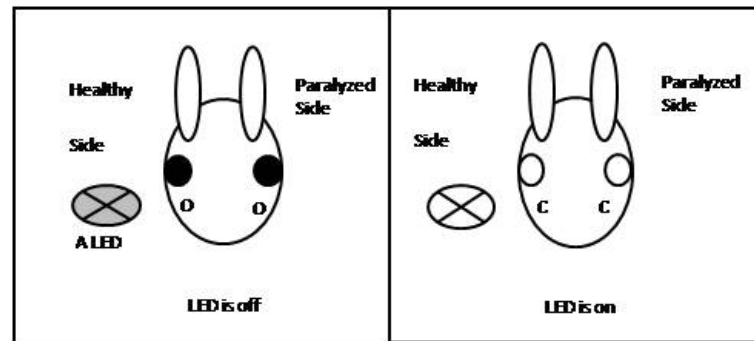

Figure 2.12 Treatment groups experiments

2.4.3 External Implant Group

Treatment group with the external implant was made to wear the frame. External implant was pasted to the paralyzed side's upper eyelid (**Figure 2.13**). This implant's size and weight was approximately 20% of the size and weight of internal implant. Device was calibrated according to right (healthy) eye. A LED is placed to right side of the rabbit's head. LED flashes caused a blink response in the healthy eye. The paralyzed side of the animal did not need a LED impulse to blink. The magnetic actuator caused the artificial blink in the paralyzed eye. 30 random light pulses were flashed to the healthy eye. Video cameras recorded the eyelid movements during the session.

2.5 Data Analysis

Data were analyzed in Microsoft Excel. The Measurements taken from Photoshop were corrected with the calibration measurements and the total eyelid movement was calculated by subtracting the position during the flash from the position before



Figure 2.13 Placement of the external implant

the flash. The corrected data was statistically tested with t-test. Specially, the comparison between the control group and treatment groups, comparison between the healthy eyelids and the paralyzed eyelids of control animals, the comparison between healthy eyelids and paralyzed eyelids of treatment groups and the comparison of the eyelids' positions before and during the flash were tested statically with wilcoxon rank sum test.

3. RESULTS

3.1 Calibration Results

As a primary concern, I investigated the electrical properties of the device. The first test measured the current through the electromagnet and the second test measured the magnetic flux density through.

3.1.1 Current Measurements on the Actuator

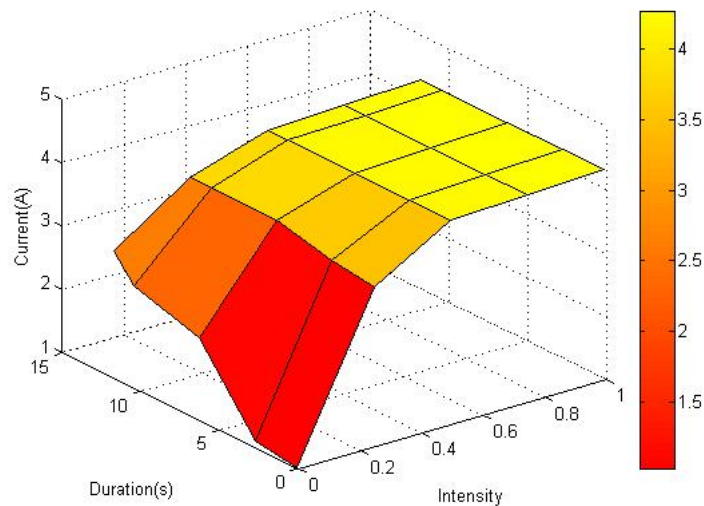

Figure 3.1 Current calibration results

The average current passing through the magnetic actuator is plotted as a function of duration and intensity arbitrary unit setting of the device in **figure 3.1**. The increase of the duration and the intensity increased the current, but after half intensity setting the increase was slowed and the current stayed constant at 4.1 A level. The duration setting had an effect on maximum current only at low intensity setting.

3.1.2 Magnetic Flux Density Produced by the Device

Magnetic flux density produced by the actuator was measured at 25 different settings in arbitrary units (Figure 3.2). Magnetic Flux density increased with duration and intensity and made a peak, then decreased. For durations 10 s and 50% intensity setting, the actuator produced the highest magnetic flux density (13 mT).

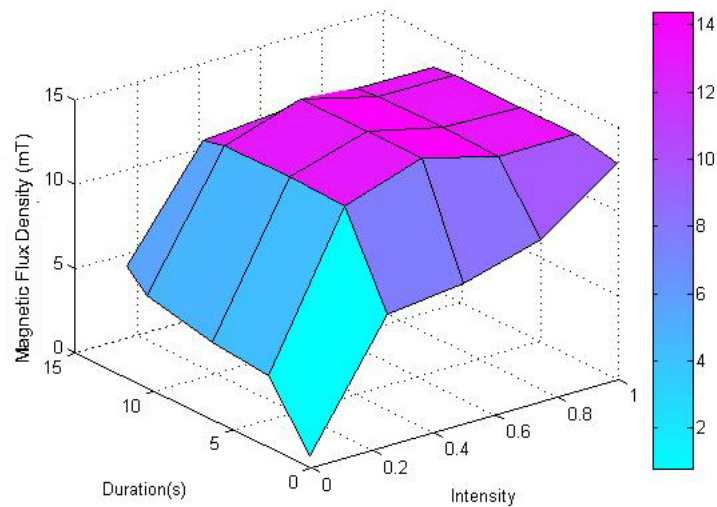

Figure 3.2 Magnetism calibration results

3.2 Experimental Results

3.2.1 A Sample Subject

A sample experiment for the treatment group with internal implant is presented in **figure 3.3**. For 30 random flashes, the positions before and during the flash in the paralyzed eyelid is given (**Figure 3.3 A**). The positions during the flash in the paralyzed eyelid stayed on a baseline of 0.05 cm. Moreover, the positions before the flash in the paralyzed eyelid was not constant. Additionally, the mean values of the positions before and during the flash were indicated (**Figure 3.3 B**).

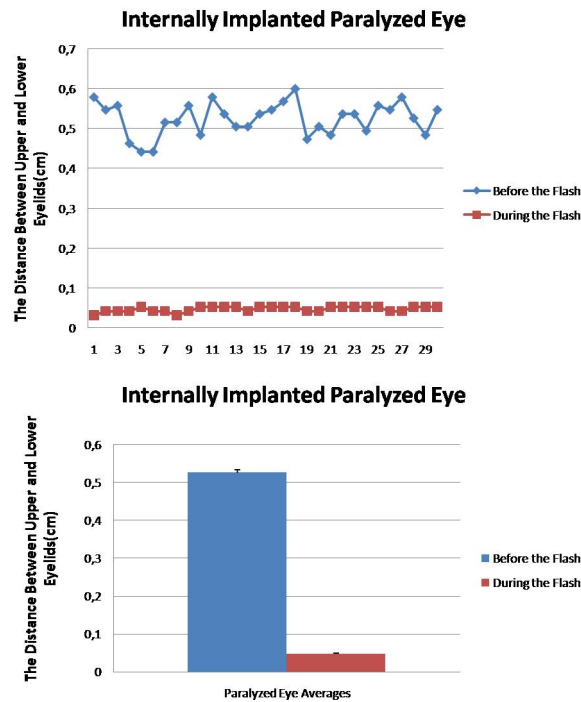

Figure 3.3 A sample experimental data for the treatment group with internal implant. **A:** The positions before and during the flash in the paralyzed eyelid during a set of experiment. **B:** the mean values of the positions before and during the flash are shown.

Table 3.1

Mean values(mm), standard deviation and standard error of mean values of the open, the closed positions and the movement of the paralyzed eyelids' of the treatment group with internal implant.

	Open			Closed			Movement		
	Mean	SD	SEM	Mean	SD	SEM	Mean	SD	SEM
1. Subject	0.636 cm	0.113	0.021	0.065 cm	0.028	0.005	0.571 cm	0.114	0.021
2. Subject	0.719 cm	0.058	0.011	0.089 cm	0.045	0.008	0.630 cm	0.073	0.013
3. Subject	0.525 cm	0.041	0.008	0.047 cm	0.007	0.001	0.478 cm	0.042	0.008
4. Subject	0.602 cm	0.046	0.008	0.148 cm	0.027	0.005	0.455 cm	0.045	0.008
5. Subject	0.445 cm	0.061	0.011	0.031 cm	0.009	0.002	0.414 cm	0.058	0.011

3.2.2 Control Group's Healthy and Paralyzed Eyes

Control group animals (n=5) was not able to close their paralyzed eye(**figure 3.5**).The mean values of the position of the paralyzed and the healthy eyelids showed in the **figure 3.4**. The paralyzed eyelids' positions before and during the flash are not significantly different. However, the healthy and paralyzed eyelids' positions before the flash (p=0.008) and the positions of the healthy eye before and during the flash are

significantly different ($p=0.008$).

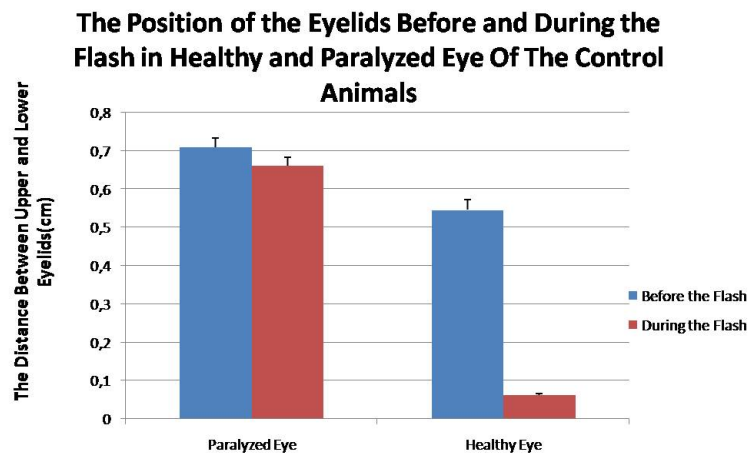

Figure 3.4 Control group's the paralyzed eyelids' and healthy eyelids' positions before and during the flash. The paralyzed eyelids' positions before and during the flash are not significantly different. However, the healthy and paralyzed eyelids' positions before the flash ($p=0.008$) and the positions of the healthy eye before and during the flash are significantly different ($p=0.008$).

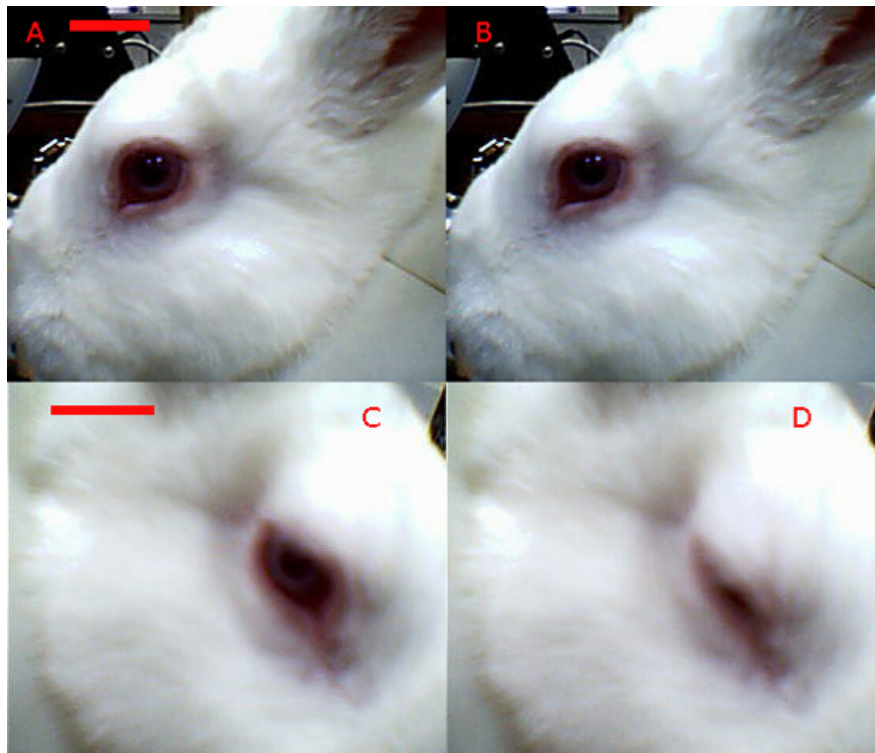

Figure 3.5 Control group. **A:** Paralyzed eye before the flash **B:** Paralyzed eye during the flash **C:** Healthy eye before the flash **D:** Healthy eye during the flash. Red bars equal to 1cm.

3.2.3 Control Group's and Treatment Groups' Paralyzed Eyes

Treatment groups could blink their paralyzed eyelids when the device was activated by the healthy eye. The mean values of the positions of paralyzed eyelids before and during the flashes of all groups were presented in **figure 3.6**. The eyelid positions before the flash in the control group and in the treatment group with external implants ($n=4$) are not significantly different, but in the treatment group with internal implants ($n=5$) are significantly different from in the control group ($p=0.031$). The eyelid positions during the flash in both treatment groups are not significantly different. The eyelid positions during the flash in the treatment group with external implant is significantly different from the position of the eyelids during the flash in the control group ($p=0.008$). The eyelid positions during the flash in the treatment group with internal implant is significantly different from the position of the eyelids during the flash in the control group ($p=0.016$).

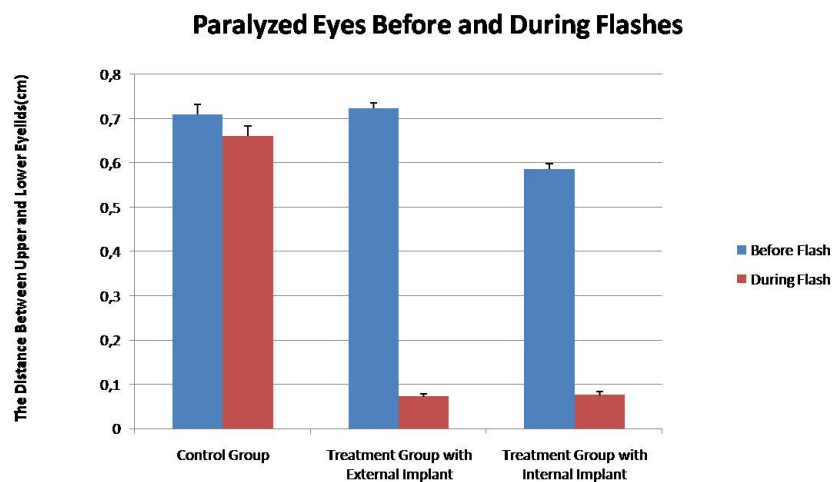

Figure 3.6 Control group and treatment groups paralyzed eyelids' position before and during the flashes. The positions of the eyelids before the flash in the control group and in the treatment group with external implants are similar (ns), but the treatment group with internal implants are significantly different from the control group ($p=0.031$). The eyelid positions during the flash in both treatment groups are not significantly different. The eyelid positions during the flash in the treatment group with external implant is significantly different from the position of the eyelids during the flash in the control group ($p=0.008$). The eyelid positions during the flash in the treatment group with internal implant is significantly different from the position of the eyelids during the flash in the control group ($p=0.016$).

3.2.4 Healthy and Paralyzed Eyes of Treatment Group with External Implant

The comparison between the positions of the healthy and paralyzed eyelids in the treatment group with external implant was shown in **figure3.8** and **figure 3.7**. The positions of the healthy and paralyzed eyelids before and during the flash in the group were statically analyzed. The treatment group's healthy eyelids' and paralyzed eyelids' position before the flash are not significantly different ($p=0.083$). The paralyzed eyelids' positions before and during the flash are significantly different ($p=0.008$). The healthy eyelids' position during the flash and the paralyzed eyelids' position during the flash is similar. The positions of the eyelids' before and during the flash are significantly different in both healthy and paralyzed eyes ($p=0.008$).

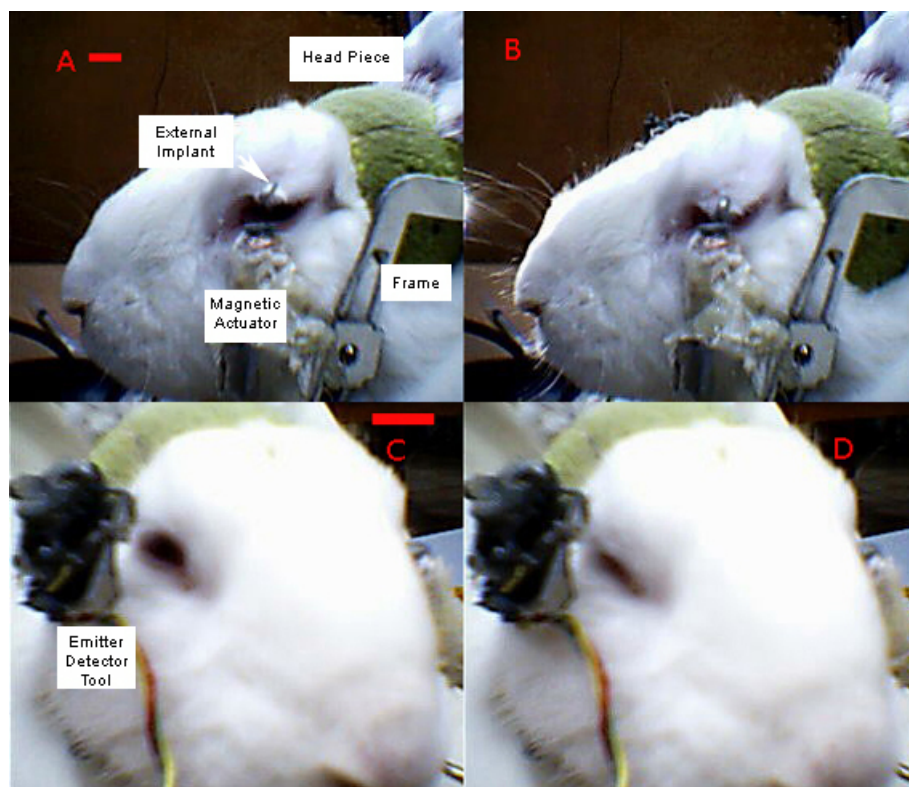

Figure 3.7 Treatment group with external implant. **A:** Paralyzed eye before the flash **B:** Paralyzed eye during the flash **C:** Healthy eye before the flash **D:** Healthy eye before the flash. Red bars equal to 1cm.

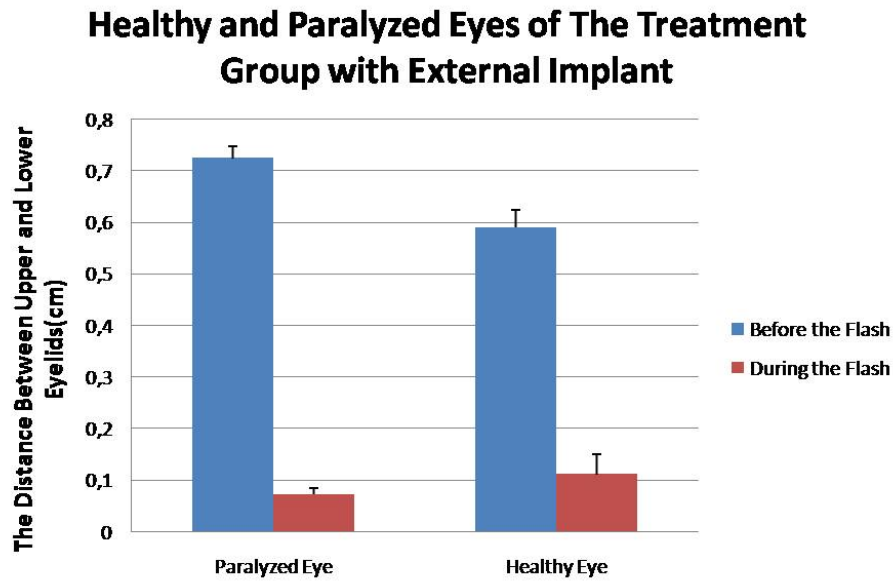

Figure 3.8 The comparison between the positions of the healthy and paralyzed eyelids in the treatment group with external implant. The treatment group's healthy eyelids' and paralyzed eyelids' position before the flash are not significantly different ($p=0.083$). The paralyzed eyelids' positions before and during the flash are significantly different ($p=0.008$). The healthy eyelids' position during the flash and the paralyzed eyelids' position during the flash is similar. The positions of the eyelids' before and during the flash are significantly different in both healthy and paralyzed eyes ($p=0.008$).

3.2.5 Healthy and Paralyzed Eyes of Treatment Group with Internal Implant

The comparison between the positions of the healthy and paralyzed eyelids in the treatment group with internal implant was shown in **figure 3.9** and **figure 3.10**. The positions of the healthy and paralyzed eyelids before and during the flash in the group were statically analyzed. The treatment group's healthy eyelids' and paralyzed eyelids' position before the flash are similar. The paralyzed eyelids' positions before and during the flash are significantly different ($p=0.008$). The healthy eyelids' position during the flash and the paralyzed eyelids' position during the flash is similar. The positions of the eyelids' before and during the flash are significantly different in both healthy and paralyzed eyes ($p=0.008$).

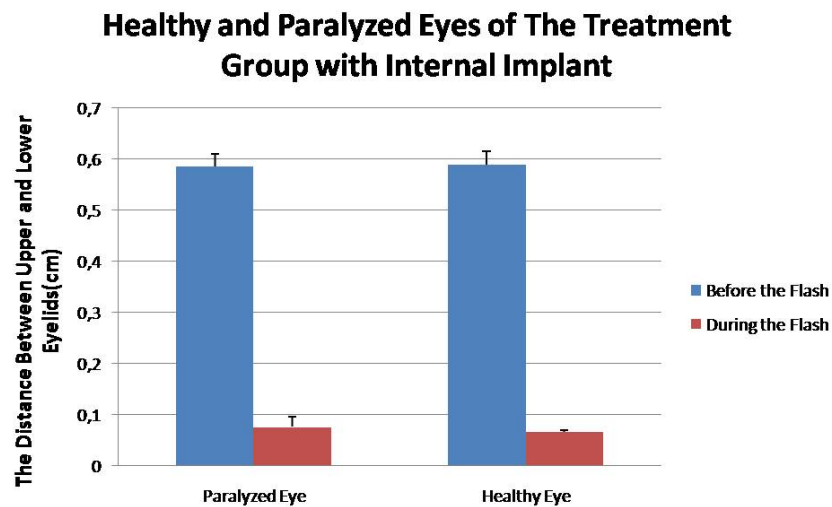

Figure 3.9 The comparison between the positions of the healthy and paralyzed eyelids in the treatment group with internal implant. The treatment group's healthy eyelids' and paralyzed eyelids' position before the flash are similar. The paralyzed eyelids' positions before and during the flash are significantly different ($p=0.008$). The healthy eyelids' position during the flash and the paralyzed eyelids' position during the flash is similar. The positions of the eyelids' before and during the flash are significantly different in both healthy and paralyzed eyes($p=0.008$).

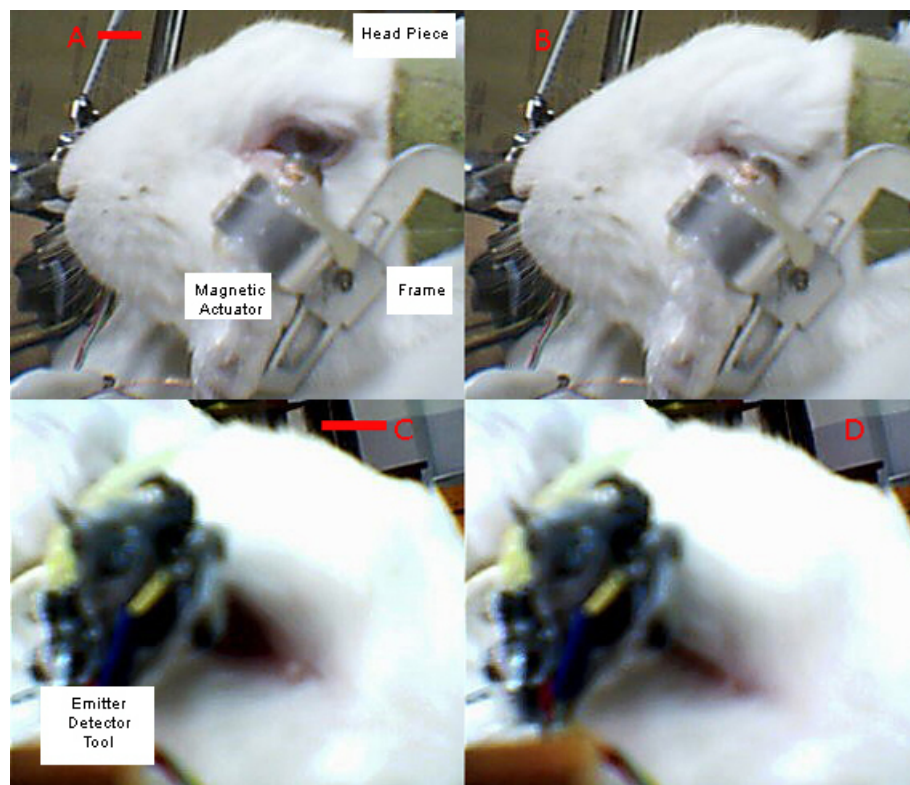

Figure 3.10 Treatment group with internal implant. **A:** Paralyzed eye before the flash **B:** Paralyzed eye during the flash **C:** Healthy eye before the flash **D:** Healthy eye during the flash. Red bars equal to 1cm.

4. DISCUSSION

The results of the thesis show that the device is a promising solution to lagophthalmos due to the facial palsy. The similarity of results between the healthy and the treated eyes' of the experimental groups supports the hypothesis.

The control group animals were not able to close their paralyzed eyes when flashes were given. The local anesthetics were successful to temporarily paralyze the animals. Not only anesthetic effects of the drugs, but also the stress on the animal disappeared in a few hours after the experiments. On the other hand, the complications due to lagophthalmos and/or the possible positive effect of the device on those complications could not be shown with this study. Further studies with subject having permanent facial palsy will give more information about the effect of the device on those complications.

The treatment group with external implant was able to close their paralyzed eyes when flashes were given. However, the open position of the paralyzed eyelids was similar to the open position of the control group's paralyzed eyelids. The external implant was not heavy enough to keep an eyelid in a position as in healthy animals. However, this partial closure of the eye can be a useful protecting for the eye from the complications. The open position can be adjusted by increasing the weight of the implant. If a commercial version of the device is produced, external implants can be colored as the skin.

External implant does not require a surgery and is a safe and effective method. On the other hand, the best results belong to the treatment group with internal implant. The healthy and the treated eyes are behaved similarly. However, a higher level of magnetic field and a larger current for producing that magnetic field were necessary for closing the eye with the internal implant. Moreover, the placement of implant during the surgery can be problematic. Figure 4.1 shows a subject whose implant was

placed too close to the front end. This subject was blinking when the flashes was given, but it could not entirely close the back part of the eye.



Figure 4.1 A problematic placement of internal implant **A:** Paralyzed eye before the flash **B:** Paralyzed eye during the flash. Red bar equals to 1cm.

A infrared filter was added to device for decreasing the effect of the day light. Although, this physical filter was able to decrease the effect of the day light, an electronic filter can also be implemented. A detector can be added to the back side of the device and can produce a day light signal which would be subtracted from the infrared detector's signal. There is only one infrared detector on the device now. For future studies one or two more infrared detectors can be added to device to make 2 or 3 levels of eye closing. New detectors can be positioned at 3 different points from upside to downside. As a result open, half open, more closed but still open and closed positions' signals can be transmitted to actuator. The magnetic field would be changed with coming signal and the eyelid could work more efficient than a binary system. However, the calibration of several detectors would be more difficult.

Although this device is tested for animals, the future devices should be tested with medical electro-magnetic standards for human use. In the current device, magnetic flux density started to decrease when duration and intensity increased. The magnetic and electrical properties of the actuator probably changed with temperature. When a pulse was applied to the actuator, the current warmed it up. This temperature change could cause a decrease in the magnetic flux density. In addition, the energy consumption of the device depended on the device settings. The optimum configuration should be studied better for a commercial device. Optimum energy consumption would

give the opportunity of portability. For example, a commercial device may operate on rechargeable Li-ion batteries.

The frame designed for the rabbits cannot be used on humans. While re-designing the frame for the humans, aesthetics, ergonomics and health issues must be considered. A human frame should look like an eyeglasses, be lightweight, and must not disturb the vision. For example, a commercial device may have a wireless communication between the frame and the circuits. Wireless communication could improve aesthetics and ergonomics.

APPENDIX A.

Table A.1
Experimental data of healthy eye of treatment group with external implants

	1. Subject			2. Subject			3. Subject			4. Subject		
	Open	Closed	Movement	Open	Closed	Movement	Open	Closed	Movement	Open	Closed	Movement
1	0.782 cm	0.067	0.715	0.579 cm	0.221	0.358	0.706 cm	0.065	0.641	0.740 cm	0.050	0.690
2	0.630 cm	0.273	0.358	0.579 cm	0.116	0.463	0.588 cm	0.047	0.541	0.630 cm	0.040	0.590
3	0.607 cm	0.213	0.393	0.600 cm	0.074	0.526	0.553 cm	0.071	0.482	0.650 cm	0.070	0.580
4	0.667 cm	0.260	0.407	0.526 cm	0.063	0.463	0.576 cm	0.059	0.518	0.650 cm	0.060	0.590
5	0.447 cm	0.140	0.307	0.537 cm	0.074	0.463	0.576 cm	0.059	0.518	0.610 cm	0.050	0.560
6	0.653 cm	0.253	0.400	0.516 cm	0.053	0.463	0.529 cm	0.059	0.471	0.550 cm	0.050	0.500
7	0.787 cm	0.380	0.407	0.526 cm	0.063	0.463	0.529 cm	0.053	0.476	0.550 cm	0.040	0.510
8	0.833 cm	0.373	0.460	0.474 cm	0.053	0.421	0.559 cm	0.047	0.512	0.570 cm	0.080	0.490
9	0.600 cm	0.160	0.440	0.568 cm	0.063	0.505	0.541 cm	0.071	0.471	0.650 cm	0.050	0.600
10	0.627 cm	0.240	0.387	0.505 cm	0.084	0.421	0.576 cm	0.059	0.518	0.570 cm	0.070	0.500
11	0.613 cm	0.180	0.433	0.463 cm	0.063	0.400	0.513 cm	0.075	0.438	0.600 cm	0.070	0.530
12	0.560 cm	0.133	0.427	0.379 cm	0.095	0.284	0.513 cm	0.063	0.450	0.530 cm	0.050	0.480
13	0.780 cm	0.320	0.460	0.411 cm	0.042	0.368	0.531 cm	0.063	0.469	0.570 cm	0.050	0.470
14	0.667 cm	0.253	0.413	0.474 cm	0.053	0.421	0.525 cm	0.056	0.469	0.620 cm	0.060	0.560
15	0.667 cm	0.320	0.347	0.621 cm	0.053	0.568	0.613 cm	0.050	0.563	0.680 cm	0.060	0.620
16	0.700 cm	0.320	0.380	0.547 cm	0.063	0.484	0.513 cm	0.050	0.463	0.650 cm	0.050	0.600
17	0.653 cm	0.140	0.513	0.589 cm	0.053	0.537	0.475 cm	0.050	0.425	0.570 cm	0.040	0.530
18	0.720 cm	0.220	0.500	0.579 cm	0.053	0.526	0.525 cm	0.056	0.469	0.560 cm	0.040	0.520
19	0.776 cm	0.309	0.467	0.600 cm	0.053	0.547	0.494 cm	0.063	0.431	0.630 cm	0.050	0.580
20	0.824 cm	0.309	0.515	0.663 cm	0.053	0.611	0.513 cm	0.088	0.425	0.650 cm	0.060	0.590
21	0.800 cm	0.194	0.606	0.568 cm	0.053	0.516	0.506 cm	0.075	0.431	0.570 cm	0.040	0.530
22	0.752 cm	0.291	0.461	0.526 cm	0.063	0.463	0.506 cm	0.063	0.444	0.570 cm	0.040	0.530
23	0.752 cm	0.273	0.479	0.547 cm	0.063	0.484	0.456 cm	0.063	0.394	0.440 cm	0.090	0.350
24	0.642 cm	0.230	0.412	0.558 cm	0.063	0.495	0.456 cm	0.050	0.406	0.610 cm	0.050	0.560
25	0.679 cm	0.236	0.442	0.615 cm	0.062	0.554	0.438 cm	0.050	0.388	0.650 cm	0.050	0.600
26	0.715 cm	0.242	0.473	0.600 cm	0.062	0.538	0.438 cm	0.050	0.388	0.550 cm	0.040	0.510
27	0.697 cm	0.176	0.521	0.600 cm	0.054	0.546	0.394 cm	0.056	0.338	0.540 cm	0.040	0.500
28	0.824 cm	0.339	0.485	0.546 cm	0.062	0.485	0.475 cm	0.050	0.425	0.400 cm	0.050	0.350
29	0.745 cm	0.212	0.533	0.592 cm	0.062	0.531	0.463 cm	0.056	0.406	0.560 cm	0.050	0.510
30	0.627 cm	0.220	0.407	0.662 cm	0.062	0.600	0.550 cm	0.125	0.425	0.616 cm	0.077	0.539

Table A.2
Experimental data of healthy eye of treatment group with internal implants

	Experiment 1			Experiment 2			Experiment 3			Experiment 4			Experiment 5		
	Open	Closed	Movement	Open	Closed	Movement	Open	Closed	Movement	Open	Closed	Movement	Open	Closed	Movement
1	0.640	0.048	0.592	0.730	0.078	0.652	0.745	0.076	0.669	0.750	0.100	0.650	0.703	0.055	0.648
2	0.616	0.048	0.568	0.652	0.070	0.583	0.733	0.051	0.682	0.630	0.040	0.590	0.559	0.055	0.503
3	0.576	0.048	0.528	0.678	0.070	0.609	0.669	0.051	0.619	0.630	0.040	0.590	0.572	0.083	0.490
4	0.592	0.056	0.536	0.687	0.070	0.617	0.632	0.069	0.562	0.540	0.030	0.510	0.559	0.048	0.510
5	0.560	0.056	0.504	0.530	0.061	0.470	0.619	0.076	0.543	0.500	0.050	0.450	0.503	0.062	0.441
6	0.704	0.064	0.640	0.635	0.043	0.591	0.707	0.051	0.657	0.530	0.040	0.490	0.510	0.048	0.462
7	0.560	0.048	0.512	0.739	0.148	0.591	0.720	0.057	0.663	0.460	0.040	0.420	0.483	0.062	0.421
8	0.640	0.064	0.576	0.617	0.052	0.565	0.669	0.063	0.606	0.380	0.030	0.350	0.690	0.069	0.621
9	0.600	0.056	0.544	0.678	0.104	0.574	0.632	0.158	0.474	0.700	0.040	0.660	0.593	0.048	0.545
10	0.560	0.072	0.488	0.696	0.104	0.591	0.625	0.215	0.411	0.690	0.120	0.570	0.600	0.055	0.545
11	0.536	0.184	0.352	0.670	0.087	0.583	0.657	0.063	0.594	0.680	0.080	0.600	0.503	0.055	0.448
12	0.560	0.072	0.488	0.591	0.052	0.539	0.619	0.051	0.568	0.540	0.040	0.500	0.545	0.055	0.490
13	0.552	0.048	0.504	0.557	0.052	0.504	0.695	0.051	0.644	0.670	0.050	0.620	0.607	0.069	0.538
14	0.544	0.056	0.488	0.478	0.043	0.435	0.657	0.076	0.581	0.680	0.060	0.620	0.503	0.062	0.441
15	0.400	0.059	0.341	0.522	0.043	0.478	0.752	0.051	0.701	0.720	0.050	0.670	0.414	0.048	0.366
16	0.412	0.059	0.353	0.617	0.052	0.565	0.720	0.051	0.669	0.700	0.060	0.640	0.628	0.062	0.566
17	0.400	0.047	0.353	0.461	0.043	0.417	0.657	0.051	0.606	0.700	0.100	0.600	0.641	0.159	0.483
18	0.382	0.047	0.335	0.478	0.043	0.435	0.695	0.063	0.632	0.630	0.060	0.600	0.538	0.055	0.483
19	0.418	0.065	0.353	0.643	0.052	0.591	0.688	0.069	0.619	0.620	0.050	0.570	0.517	0.062	0.455
20	0.400	0.059	0.341	0.591	0.052	0.539	0.695	0.063	0.632	0.650	0.050	0.600	0.621	0.097	0.524
21	0.465	0.094	0.371	0.643	0.043	0.600	0.518	0.221	0.297	0.672	0.064	0.608	0.490	0.055	0.434
22	0.429	0.088	0.341	0.522	0.052	0.470	0.575	0.069	0.505	0.608	0.064	0.544	0.517	0.097	0.421
23	0.400	0.059	0.341	0.609	0.043	0.565	0.581	0.063	0.518	0.640	0.072	0.568	0.634	0.110	0.524
24	0.453	0.059	0.394	0.591	0.043	0.548	0.594	0.063	0.531	0.672	0.064	0.608	0.655	0.069	0.586
25	0.459	0.059	0.400	0.652	0.043	0.609	0.518	0.095	0.423	0.632	0.064	0.568	0.614	0.062	0.552
26	0.482	0.088	0.394	0.609	0.070	0.539	0.587	0.095	0.493	0.608	0.056	0.552	0.690	0.069	0.621
27	0.476	0.082	0.394	0.565	0.043	0.522	0.537	0.114	0.423	0.624	0.064	0.560	0.607	0.083	0.524
28	0.400	0.047	0.353	0.722	0.070	0.652	0.537	0.051	0.486	0.608	0.072	0.536	0.497	0.055	0.441
29	0.394	0.059	0.335	0.539	0.070	0.470	0.663	0.051	0.613	0.672	0.080	0.592	0.552	0.055	0.497
30	0.465	0.059	0.406	0.591	0.061	0.530	0.537	0.139	0.398	0.672	0.072	0.600	0.559	0.062	0.497

Table A.3
Experimental data of healthy eye of control group

	Experiment1			Experiment2			Experiment3			Experiment4			Experiment5		
	Open	Closed	Movement	Open	Closed	Movement	Open	Closed	Movement	Open	Closed	Movement	Open	Closed	Movement
1	0.457	0.057	0.400	0.591	0.068	0.523	0.791	0.082	0.710	0.658	0.039	0.619	0.716	0.072	0.644
2	0.467	0.038	0.429	0.517	0.062	0.455	0.579	0.057	0.522	0.480	0.046	0.434	0.761	0.313	0.447
3	0.541	0.046	0.495	0.548	0.049	0.498	0.653	0.065	0.587	0.619	0.046	0.573	0.769	0.072	0.698
4	0.488	0.046	0.442	0.622	0.062	0.560	0.636	0.065	0.571	0.542	0.046	0.495	0.680	0.045	0.635
5	0.480	0.046	0.434	0.468	0.068	0.400	0.547	0.057	0.489	0.503	0.054	0.449	0.743	0.054	0.689
6	0.510	0.053	0.457	0.591	0.062	0.529	0.579	0.057	0.522	0.480	0.054	0.476	0.626	0.054	0.573
7	0.541	0.046	0.495	0.677	0.074	0.603	0.375	0.049	0.326	0.465	0.046	0.418	0.707	0.072	0.635
8	0.510	0.046	0.465	0.535	0.062	0.474	0.506	0.057	0.449	0.449	0.046	0.403	0.752	0.054	0.698
9	0.320	0.046	0.274	0.548	0.055	0.492	0.522	0.057	0.465	0.526	0.046	0.480	0.599	0.045	0.555
10	0.457	0.061	0.396	0.474	0.049	0.425	0.669	0.049	0.620	0.488	0.046	0.441	0.671	0.054	0.617
11	0.510	0.053	0.457	0.535	0.055	0.480	0.587	0.057	0.530	0.480	0.054	0.476	0.653	0.054	0.599
12	0.434	0.046	0.389	0.554	0.055	0.498	0.587	0.049	0.538	0.495	0.054	0.441	0.492	0.072	0.421
13	0.579	0.061	0.518	0.498	0.062	0.437	0.636	0.049	0.587	0.526	0.054	0.472	0.626	0.054	0.573
14	0.510	0.063	0.457	0.566	0.049	0.517	0.587	0.049	0.538	0.589	0.080	0.509	0.599	0.045	0.555
15	0.404	0.046	0.358	0.548	0.172	0.375	0.465	0.049	0.416	0.520	0.051	0.469	0.608	0.045	0.564
16	0.823	0.053	0.770	0.412	0.062	0.351	0.481	0.057	0.424	0.457	0.057	0.400	0.635	0.054	0.582
17	0.800	0.061	0.739	0.587	0.064	0.523	0.432	0.049	0.383	0.446	0.057	0.389	0.582	0.089	0.492
18	0.510	0.046	0.465	0.597	0.080	0.517	0.489	0.049	0.441	0.503	0.051	0.451	0.519	0.045	0.474
19	0.610	0.063	0.556	0.507	0.053	0.453	0.653	0.049	0.604	0.417	0.046	0.371	0.599	0.054	0.546
20	0.366	0.061	0.305	0.613	0.069	0.544	0.522	0.041	0.481	0.446	0.046	0.400	0.573	0.072	0.501
21	0.404	0.053	0.350	0.544	0.053	0.491	0.473	0.057	0.416	0.571	0.057	0.514	0.653	0.072	0.582
22	0.404	0.046	0.358	0.693	0.107	0.587	0.481	0.082	0.400	0.446	0.046	0.400	0.537	0.054	0.483
23	0.434	0.061	0.373	0.592	0.053	0.539	0.547	0.057	0.489	0.469	0.051	0.417	0.599	0.045	0.555
24	0.510	0.076	0.434	0.635	0.075	0.560	0.489	0.049	0.441	0.464	0.080	0.384	0.608	0.054	0.555
25	0.488	0.061	0.427	0.544	0.053	0.491	0.424	0.049	0.375	0.504	0.117	0.392	0.465	0.054	0.412
26	0.564	0.061	0.503	0.560	0.048	0.512	0.579	0.057	0.522	0.464	0.056	0.408	0.582	0.072	0.510
27	0.427	0.046	0.381	0.661	0.053	0.608	0.424	0.057	0.367	0.384	0.096	0.288	0.698	0.081	0.617
28	0.404	0.046	0.358	0.613	0.123	0.491	0.424	0.065	0.359	0.408	0.144	0.264	0.635	0.089	0.546
29	0.465	0.061	0.404	0.600	0.213	0.387	0.441	0.049	0.392	0.440	0.064	0.376	0.671	0.072	0.599
30	0.610	0.084	0.526	0.587	0.080	0.507	0.416	0.049	0.367	0.480	0.072	0.408	0.734	0.072	0.662

Table A.4
Experimental data of paralyzed eye of treatment group with external implants

	1. Subject			2. Subject			3. Subject			4. Subject		
	Open	Closed	Movement	Open	Closed	Movement	Open	Closed	Movement	Open	Closed	Movement
1	0.764 cm	0.055	0.709	0.800 cm	0.080	0.720	0.747 cm	0.080	0.667	0.708 cm	0.108	0.600
2	0.800 cm	0.073	0.727	0.800 cm	0.027	0.773	0.853 cm	0.080	0.773	0.754 cm	0.092	0.662
3	0.418 cm	0.036	0.382	0.813 cm	0.067	0.747	0.773 cm	0.133	0.640	0.708 cm	0.077	0.631
4	0.709 cm	0.055	0.655	0.760 cm	0.027	0.733	0.707 cm	0.080	0.627	0.800 cm	0.108	0.692
5	0.727 cm	0.055	0.673	0.773 cm	0.027	0.747	0.693 cm	0.107	0.587	0.708 cm	0.077	0.631
6	0.600 cm	0.055	0.545	0.800 cm	0.053	0.747	0.707 cm	0.107	0.600	0.723 cm	0.108	0.615
7	0.764 cm	0.036	0.727	0.815 cm	0.031	0.785	0.653 cm	0.120	0.533	0.600 cm	0.077	0.523
8	0.815 cm	0.062	0.754	0.769 cm	0.015	0.754	0.720 cm	0.107	0.613	0.600 cm	0.092	0.508
9	0.800 cm	0.062	0.738	0.754 cm	0.015	0.738	0.707 cm	0.107	0.600	0.538 cm	0.108	0.431
10	0.800 cm	0.073	0.727	0.815 cm	0.031	0.785	0.640 cm	0.080	0.560	0.708 cm	0.077	0.631
11	0.846 cm	0.077	0.769	0.769 cm	0.062	0.708	0.693 cm	0.133	0.560	0.646 cm	0.092	0.554
12	0.738 cm	0.062	0.677	0.831 cm	0.031	0.800	0.760 cm	0.080	0.680	0.631 cm	0.077	0.554
13	0.738 cm	0.062	0.677	0.815 cm	0.031	0.785	0.720 cm	0.107	0.613	0.646 cm	0.092	0.554
14	0.631 cm	0.046	0.585	0.862 cm	0.031	0.831	0.640 cm	0.080	0.560	0.600 cm	0.077	0.523
15	0.769 cm	0.062	0.708	0.877 cm	0.031	0.846	0.707 cm	0.080	0.627	0.754 cm	0.108	0.646
16	0.754 cm	0.062	0.692	0.769 cm	0.031	0.738	0.627 cm	0.107	0.520	0.708 cm	0.108	0.600
17	0.723 cm	0.062	0.662	0.800 cm	0.067	0.733	0.720 cm	0.093	0.627	0.646 cm	0.077	0.569
18	0.769 cm	0.062	0.708	0.815 cm	0.031	0.785	0.693 cm	0.133	0.560	0.692 cm	0.092	0.600
19	0.778 cm	0.048	0.730	0.769 cm	0.031	0.738	0.720 cm	0.133	0.587	0.646 cm	0.108	0.538
20	0.764 cm	0.055	0.709	0.800 cm	0.043	0.757	0.653 cm	0.080	0.573	0.615 cm	0.077	0.538
21	0.745 cm	0.055	0.691	0.831 cm	0.046	0.785	0.640 cm	0.080	0.560	0.646 cm	0.077	0.569
22	0.782 cm	0.073	0.709	0.815 cm	0.046	0.769	0.707 cm	0.107	0.600	0.738 cm	0.092	0.646
23	0.691 cm	0.055	0.636	0.738 cm	0.046	0.692	0.667 cm	0.080	0.587	0.646 cm	0.092	0.554
24	0.746 cm	0.063	0.683	0.708 cm	0.046	0.662	0.693 cm	0.080	0.613	0.615 cm	0.108	0.508
25	0.836 cm	0.055	0.782	0.708 cm	0.015	0.692	0.640 cm	0.107	0.533	0.708 cm	0.092	0.615
26	0.764 cm	0.055	0.709	0.708 cm	0.062	0.646	0.707 cm	0.107	0.600	0.738 cm	0.108	0.631
27	0.764 cm	0.073	0.691	0.783 cm	0.050	0.733	0.693 cm	0.080	0.613	0.615 cm	0.092	0.523
28	0.709 cm	0.055	0.655	0.767 cm	0.050	0.717	0.640 cm	0.080	0.560	0.646 cm	0.077	0.569
29	0.764 cm	0.073	0.691	0.800 cm	0.067	0.733	0.653 cm	0.080	0.573	0.646 cm	0.077	0.569
30	0.745 cm	0.055	0.691	0.800 cm	0.050	0.750	0.693 cm	0.107	0.587	0.615 cm	0.092	0.523

Table A.5
Experimental data of paralyzed eye of treatment group with internal implants

	1. Subject		2. Subject		3. Subject		4. Subject		5. Subject						
	Open	Closed	Open	Closed	Open	Closed	Open	Closed	Open	Closed					
1	0.729 cm	0.057	0.671	0.741 cm	0.052	0.690	0.579 cm	0.032	0.547	0.670 cm	0.150	0.520	0.526 cm	0.042	0.484
2	0.671 cm	0.057	0.614	0.621 cm	0.069	0.552	0.547 cm	0.042	0.505	0.680 cm	0.140	0.540	0.484 cm	0.021	0.463
3	0.571 cm	0.057	0.514	0.638 cm	0.069	0.569	0.558 cm	0.042	0.516	0.550 cm	0.110	0.440	0.558 cm	0.042	0.516
4	0.843 cm	0.043	0.800	0.672 cm	0.052	0.621	0.463 cm	0.042	0.421	0.600 cm	0.130	0.470	0.442 cm	0.021	0.421
5	0.557 cm	0.057	0.500	0.724 cm	0.086	0.638	0.442 cm	0.053	0.389	0.520 cm	0.140	0.380	0.526 cm	0.032	0.495
6	0.771 cm	0.043	0.729	0.672 cm	0.069	0.603	0.442 cm	0.042	0.400	0.580 cm	0.150	0.430	0.516 cm	0.021	0.495
7	0.786 cm	0.057	0.729	0.655 cm	0.069	0.586	0.516 cm	0.042	0.474	0.540 cm	0.120	0.420	0.526 cm	0.042	0.484
8	0.771 cm	0.200	0.571	0.707 cm	0.069	0.638	0.516 cm	0.032	0.484	0.510 cm	0.130	0.380	0.516 cm	0.032	0.484
9	0.686 cm	0.043	0.643	0.724 cm	0.052	0.672	0.558 cm	0.042	0.516	0.580 cm	0.180	0.400	0.558 cm	0.042	0.516
10	0.757 cm	0.057	0.700	0.672 cm	0.069	0.603	0.484 cm	0.053	0.432	0.600 cm	0.140	0.460	0.442 cm	0.032	0.411
11	0.571 cm	0.057	0.514	0.603 cm	0.241	0.362	0.579 cm	0.053	0.526	0.610 cm	0.150	0.460	0.411 cm	0.032	0.379
12	0.686 cm	0.071	0.614	0.793 cm	0.241	0.552	0.537 cm	0.053	0.484	0.620 cm	0.160	0.460	0.442 cm	0.042	0.400
13	0.586 cm	0.057	0.529	0.831 cm	0.108	0.723	0.505 cm	0.053	0.453	0.510 cm	0.140	0.370	0.400 cm	0.021	0.379
14	0.671 cm	0.057	0.614	0.754 cm	0.077	0.677	0.505 cm	0.042	0.463	0.620 cm	0.160	0.460	0.442 cm	0.032	0.411
15	0.729 cm	0.057	0.671	0.738 cm	0.077	0.662	0.537 cm	0.053	0.484	0.590 cm	0.140	0.450	0.484 cm	0.042	0.442
16	0.586 cm	0.057	0.529	0.785 cm	0.077	0.708	0.547 cm	0.053	0.495	0.620 cm	0.120	0.500	0.411 cm	0.032	0.379
17	0.586 cm	0.071	0.514	0.723 cm	0.092	0.631	0.568 cm	0.053	0.516	0.600 cm	0.130	0.470	0.484 cm	0.042	0.442
18	0.429 cm	0.057	0.371	0.692 cm	0.077	0.615	0.600 cm	0.053	0.547	0.580 cm	0.190	0.390	0.442 cm	0.021	0.421
19	0.514 cm	0.057	0.457	0.738 cm	0.108	0.631	0.474 cm	0.042	0.432	0.640 cm	0.150	0.490	0.389 cm	0.021	0.368
20	0.571 cm	0.071	0.500	0.723 cm	0.108	0.615	0.505 cm	0.042	0.463	0.600 cm	0.130	0.470	0.442 cm	0.021	0.421
21	0.471 cm	0.071	0.400	0.785 cm	0.123	0.662	0.484 cm	0.053	0.432	0.640 cm	0.140	0.500	0.368 cm	0.021	0.347
22	0.457 cm	0.086	0.371	0.708 cm	0.077	0.631	0.537 cm	0.053	0.484	0.580 cm	0.150	0.430	0.442 cm	0.042	0.400
23	0.571 cm	0.057	0.514	0.800 cm	0.077	0.723	0.537 cm	0.053	0.484	0.670 cm	0.250	0.420	0.411 cm	0.032	0.379
24	0.486 cm	0.057	0.429	0.754 cm	0.077	0.677	0.495 cm	0.053	0.442	0.640 cm	0.120	0.520	0.379 cm	0.021	0.358
25	0.729 cm	0.057	0.671	0.785 cm	0.077	0.708	0.558 cm	0.053	0.505	0.620 cm	0.140	0.480	0.358 cm	0.032	0.326
26	0.571 cm	0.071	0.500	0.754 cm	0.062	0.692	0.547 cm	0.042	0.505	0.590 cm	0.160	0.430	0.389 cm	0.032	0.358
27	0.629 cm	0.057	0.571	0.600 cm	0.092	0.508	0.579 cm	0.042	0.537	0.640 cm	0.130	0.510	0.400 cm	0.032	0.368
28	0.786 cm	0.057	0.729	0.738 cm	0.077	0.662	0.526 cm	0.053	0.474	0.570 cm	0.140	0.430	0.421 cm	0.032	0.389
29	0.771 cm	0.086	0.686	0.738 cm	0.062	0.677	0.484 cm	0.053	0.432	0.630 cm	0.160	0.470	0.316 cm	0.021	0.295
30	0.543 cm	0.057	0.486	0.692 cm	0.092	0.600	0.547 cm	0.053	0.495	0.670 cm	0.180	0.490	0.421 cm	0.042	0.379

Table A.6
Experimental data of paralyzed eye of control group.

	1. Subject			2. Subject			3. Subject			4. Subject			5. Subject		
	Open	Closed	Movement	Open	Closed	Movement	Open	Closed	Movement	Open	Closed	Movement	Open	Closed	Movement
1	0.607 cm	0.579	0.028	0.594 cm	0.581	0.013	0.760 cm	0.713	0.047	0.738 cm	0.683	0.056	0.770 cm	0.730	0.040
2	0.614 cm	0.559	0.055	0.600 cm	0.574	0.026	0.753 cm	0.727	0.027	0.722 cm	0.683	0.040	0.780 cm	0.740	0.040
3	0.593 cm	0.579	0.014	0.619 cm	0.587	0.032	0.733 cm	0.693	0.040	0.722 cm	0.698	0.024	0.770 cm	0.710	0.060
4	0.607 cm	0.559	0.048	0.606 cm	0.587	0.019	0.733 cm	0.687	0.047	0.730 cm	0.675	0.056	0.780 cm	0.700	0.080
5	0.690 cm	0.607	0.083	0.600 cm	0.574	0.026	0.747 cm	0.693	0.053	0.722 cm	0.690	0.032	0.760 cm	0.710	0.050
6	0.683 cm	0.641	0.041	0.594 cm	0.581	0.013	0.727 cm	0.673	0.053	0.754 cm	0.667	0.087	0.760 cm	0.690	0.070
7	0.640 cm	0.600	0.040	0.594 cm	0.574	0.019	0.747 cm	0.693	0.053	0.730 cm	0.659	0.071	0.780 cm	0.710	0.070
8	0.653 cm	0.593	0.060	0.606 cm	0.587	0.019	0.760 cm	0.713	0.047	0.690 cm	0.667	0.024	0.780 cm	0.730	0.050
9	0.633 cm	0.587	0.047	0.619 cm	0.581	0.039	0.747 cm	0.713	0.033	0.675 cm	0.643	0.032	0.750 cm	0.730	0.020
10	0.600 cm	0.536	0.064	0.594 cm	0.581	0.013	0.733 cm	0.660	0.073	0.690 cm	0.651	0.040	0.780 cm	0.680	0.100
11	0.600 cm	0.568	0.032	0.606 cm	0.574	0.032	0.767 cm	0.720	0.047	0.698 cm	0.651	0.048	0.780 cm	0.740	0.040
12	0.624 cm	0.592	0.032	0.619 cm	0.587	0.032	0.747 cm	0.707	0.040	0.690 cm	0.643	0.048	0.760 cm	0.720	0.040
13	0.620 cm	0.587	0.033	0.606 cm	0.587	0.019	0.733 cm	0.700	0.033	0.675 cm	0.627	0.048	0.770 cm	0.720	0.050
14	0.512 cm	0.480	0.032	0.600 cm	0.581	0.019	0.727 cm	0.687	0.040	0.758 cm	0.703	0.055	0.780 cm	0.700	0.080
15	0.568 cm	0.424	0.144	0.600 cm	0.574	0.026	0.733 cm	0.693	0.040	0.745 cm	0.709	0.036	0.780 cm	0.710	0.070
16	0.712 cm	0.624	0.088	0.606 cm	0.581	0.026	0.753 cm	0.700	0.053	0.758 cm	0.691	0.067	0.760 cm	0.720	0.040
17	0.753 cm	0.707	0.047	0.697 cm	0.623	0.074	0.733 cm	0.673	0.060	0.727 cm	0.691	0.036	0.750 cm	0.690	0.060
18	0.707 cm	0.593	0.113	0.680 cm	0.640	0.040	0.747 cm	0.707	0.040	0.745 cm	0.703	0.042	0.710 cm	0.690	0.020
19	0.633 cm	0.540	0.093	0.686 cm	0.663	0.023	0.733 cm	0.660	0.073	0.739 cm	0.709	0.030	0.760 cm	0.680	0.080
20	0.676 cm	0.600	0.076	0.697 cm	0.646	0.051	0.767 cm	0.720	0.047	0.752 cm	0.703	0.048	0.760 cm	0.740	0.020
21	0.743 cm	0.676	0.067	0.680 cm	0.646	0.034	0.747 cm	0.707	0.040	0.758 cm	0.721	0.036	0.780 cm	0.720	0.060
22	0.676 cm	0.610	0.067	0.680 cm	0.640	0.040	0.733 cm	0.700	0.033	0.745 cm	0.697	0.048	0.760 cm	0.720	0.040
23	0.686 cm	0.610	0.076	0.686 cm	0.640	0.046	0.733 cm	0.660	0.073	0.764 cm	0.709	0.055	0.740 cm	0.680	0.060
24	0.676 cm	0.543	0.133	0.697 cm	0.651	0.046	0.767 cm	0.720	0.047	0.733 cm	0.685	0.048	0.780 cm	0.740	0.040
25	0.707 cm	0.660	0.047	0.691 cm	0.663	0.029	0.747 cm	0.707	0.040	0.739 cm	0.691	0.048	0.770 cm	0.730	0.040
26	0.753 cm	0.707	0.047	0.680 cm	0.651	0.029	0.720 cm	0.700	0.020	0.739 cm	0.685	0.055	0.760 cm	0.720	0.040
27	0.747 cm	0.680	0.067	0.697 cm	0.646	0.051	0.727 cm	0.680	0.047	0.727 cm	0.667	0.061	0.780 cm	0.710	0.070
28	0.727 cm	0.707	0.020	0.691 cm	0.651	0.040	0.733 cm	0.693	0.040	0.715 cm	0.667	0.048	0.770 cm	0.720	0.050
29	0.747 cm	0.720	0.027	0.703 cm	0.663	0.040	0.753 cm	0.700	0.053	0.745 cm	0.679	0.067	0.780 cm	0.730	0.050
30	0.753 cm	0.680	0.073	0.697 cm	0.663	0.034	0.733 cm	0.673	0.060	0.758 cm	0.703	0.055	0.760 cm	0.700	0.060

Table A.7

Mean values, standard deviation and standard error of mean values of the open, the closed positions and the movement of the paralyzed eyelids' of the treatment group with external implant.

	Open			Closed			Movement		
	Mean	SD	SEM	Mean	SD	SEM	Mean	SD	SEM
1. Subject	0.742 cm	0.080	0.015	0.059 cm	0.010	0.002	0.683 cm	0.075	0.014
2. Subject	0.789 cm	0.041	0.007	0.041 cm	0.017	0.003	0.748 cm	0.044	0.008
3. Subject	0.696 cm	0.048	0.009	0.098 cm	0.019	0.004	0.598 cm	0.050	0.009
4. Subject	0.668 cm	0.059	0.011	0.091 cm	0.013	0.002	0.577 cm	0.057	0.010

Table A.8

Mean values, standard deviation and standard error of mean values of the open, the closed positions and the movement of the paralyzed eyelids' of the treatment group with internal implant.

	Open			Closed			Movement		
	Mean	SD	SEM	Mean	SD	SEM	Mean	SD	SEM
1. Subject	0.636 cm	0.113	0.021	0.065 cm	0.028	0.005	0.571 cm	0.114	0.021
2. Subject	0.719 cm	0.058	0.011	0.089 cm	0.045	0.008	0.630 cm	0.073	0.013
3. Subject	0.525 cm	0.041	0.008	0.047 cm	0.007	0.001	0.478 cm	0.042	0.008
4. Subject	0.602 cm	0.046	0.008	0.148 cm	0.027	0.005	0.455 cm	0.045	0.008
5. Subject	0.445 cm	0.061	0.011	0.031 cm	0.009	0.002	0.414 cm	0.058	0.011

Table A.9

Mean values, standard deviation and standard error of mean values of the open, the closed positions and the movement of the paralyzed eyelids' of control group.

	Open			Closed			Movement		
	Mean	SD	SEM	Mean	SD	SEM	Mean	SD	SEM
1. Subject	0.665 cm	0.063	0.012	0.605 cm	0.068	0.012	0.060 cm	0.032	0.006
2. Subject	0.644 cm	0.045	0.008	0.613 cm	0.036	0.007	0.032 cm	0.014	0.002
3. Subject	0.742 cm	0.013	0.002	0.696 cm	0.019	0.003	0.047 cm	0.013	0.002
4. Subject	0.730 cm	0.025	0.005	0.682 cm	0.023	0.004	0.048 cm	0.014	0.003
5. Subject	0.767 cm	0.016	0.003	0.714 cm	0.019	0.003	0.053 cm	0.019	0.003

Table A.10

Mean values, standard deviation and standard error of mean values of the open, the closed positions and the movement of the healthy eyelids' of the treatment group with external implant.

	Open			Closed			Movement		
	Mean	SD	SEM	Mean	SD	SEM	Mean	SD	SEM
1. Subject	0.694 cm	0.089	0.016	0.243 cm	0.075	0.014	0.452 cm	0.080	0.015
2. Subject	0.552 cm	0.065	0.012	0.068 cm	0.032	0.006	0.484 cm	0.073	0.013
3. Subject	0.521 cm	0.061	0.011	0.061 cm	0.015	0.003	0.460 cm	0.061	0.011
4. Subject	0.590 cm	0.068	0.013	0.054 cm	0.013	0.002	0.536 cm	0.070	0.013

Table A.11

Mean values, standard deviation and standard error of mean values of the open, the closed positions and the movement of the healthy eyelids' of the treatment group with internal implant.

	Open			Closed			Movement		
	Mean	SD	SEM	Mean	SD	SEM	Mean	SD	SEM
1. Subject	0.503 cm	0.091	0.017	0.065 cm	0.026	0.005	0.438 cm	0.094	0.017
2. Subject	0.610 cm	0.076	0.014	0.062 cm	0.024	0.004	0.548 cm	0.064	0.012
3. Subject	0.641 cm	0.069	0.013	0.080 cm	0.046	0.008	0.561 cm	0.100	0.018
4. Subject	0.627 cm	0.081	0.015	0.060 cm	0.021	0.004	0.567 cm	0.071	0.013
5. Subject	0.570 cm	0.070	0.013	0.068 cm	0.023	0.004	0.503 cm	0.066	0.012

Table A.12

Mean values, standard deviation and standard error of mean values of the open, the closed positions and the movement of the healthy eyelids' of Control group

	Open			Closed			Movement		
	Mean	SD	SEM	Mean	SD	SEM	Mean	SD	SEM
1. Subject	0.501 cm	0.108	0.020	0.054 cm	0.010	0.002	0.447 cm	0.106	0.019
2. Subject	0.567 cm	0.062	0.011	0.073 cm	0.037	0.007	0.494 cm	0.064	0.012
3. Subject	0.533 cm	0.095	0.017	0.055 cm	0.009	0.002	0.478 cm	0.092	0.017
4. Subject	0.491 cm	0.060	0.011	0.060 cm	0.023	0.004	0.431 cm	0.071	0.013
5. Subject	0.636 cm	0.078	0.014	0.069 cm	0.048	0.009	0.567 cm	0.077	0.014

REFERENCES

1. Rubin, L. R., *The Paralyzed Face*, Missouri: Mosby-Year Book,Inc., 1991.
2. Fox, S. A., *Lid Surgery-Current Concepts*, New York: Grune and Stratton,Inc., 1972.
3. Griffith, D. G., *Cutaneous Abnormalities of The Eyelid and Face, Part 1*, Mcgraw-Hill Book, Inc., 1987.
4. C.B.Stephenson, *Upper-eyelid Blepharoplasty*, Vol. 37 of *International Ophthalmology Clinics, Aesthetic Ophthalmic plastic surgery*, pp. 123–130. Philadelphia,Pennsylvania: Lippincott-Raven Publishers, 1997.
5. Rubin, L. R., ed., *Reanimation of The Paralyzed Face new approaches*, Missouri: Mosby-Year Book,Inc., 1991.
6. B.M.Zide, *Anatomy of the Eyelids*, Vol. 8 of *Clinics In Plastic Surgery*, pp. 623–634. Philadelphia: W.B. Saunders Company, October 1981.
7. S.M. Louis, P., *Medical Treatment for Bell's Palsy*, Missouri: Mosby-Year Book,Inc., 1991.
8. Barker, T., *Upper Blepharoplasty*, Vol. 8/4 of *Clinics In Plastic Surgery*, pp. 635–641. Philadelphia: W.B. Saunders Company, October 1981.
9. May, M., *Facial Paralysis:Differential Diagnosis and Indications for Surgical Therapy*, Vol. 6/3 of *Clinics In Plastic Surgery*, pp. 275–286. Philadelphia: W.B. Saunders Company, July 1979.
10. Wolfe, S., *Eyelid Reconstruction*, Vol. 5/4 of *Clinics In Plastic Surgery*, pp. 525–531. Philadelphia: W.B. Saunders Company, October 1978.
11. andP.A.D. Rubin, E. C., *Upper and Lower Eyelid Retraction*, Vol. 37 of *International Ophthalmology Clinics, Advances in Ophthalmic plastic surgery*, pp. 45–58. Philadelphia,Pennsylvania: Lippincott-Raven Publishers, 1997.
12. Mustarde, J., *Correction of Ptosis by Split Lid Resection*, Vol. 5/4 of *Clinics In Plastic Surgery*, pp. 533–536. Philadelphia: W.B. Saunders Company, October 1978.
13. Guy, C., and J.Ransohoff, *The Palpebral Spring fot Paralysis of the Upper Eyelid*, Boston: Little,Brown And Company, 1991.
14. Harnwell, G. P., *Principles of Electricity and Electromagnetism*, USA: Mcgraw-Hill Book company,Inc, 1949.
15. Hallén, E., *Electromagnetic Theory*, London: Chapman & Hall,Inc, 1962.
16. Reitz, J. R., *Electromagnetic Theory*, Japan: Addison Wesley Publishing,Inc., 1969.
17. Walsh, J. B., *Electromagnetic Theory and Engineering Applications*, USA: The Ronald Press company, 1960.
18. Tombouliau, D., *Electric and Magnetic Fields*, Harcourt: Brace & World,Inc, 1965.
19. Kong, J. A., ed., *Research Topics In Electromagnetic Wave Theory*, USA: John Wiley & Sons,Inc, 1981.

20. Cocherová, E., and V.Štofanič, “Analysis of electromagnetic fields induced in implanted biomedical device wires using tl model,” preprint, Department of Radioelectronics, FEI STU, 2006.