

APPLICATION OF DATA ENVELOPMENT ANALYSIS TO
CHEMICAL ENGINEERING

by

Gökay Serdar ERGÜN

B.S. in Ch.E., Boğaziçi University, 2001

Submitted to the Institute for Graduate Studies in
Science and Engineering in partial fulfillment of
the requirements for the degree of
Master of Science

Graduate Program in Chemical Engineering

Boğaziçi University

2010

ACKNOWLEDGMENTS

I would like to express my sincere gratitude to my thesis supervisor Prof. Dr. Uğur Akman for his invaluable support, guidance, patience and encouragement during my thesis work.

I would also like to thank to the members of my thesis committee for their time devoted to read and comment on my thesis as well as my chemical engineering professors who provided me a high-quality education.

I would also like to thank my father Dağistan Ergün, my mother Seniha Ergün and my unique and older brother Hacı Haydar Ergün.

I am also indebted to all my friends, especially Nihan Fırat, Özgür Dökdök, İsmail Koç and İlder Çanım for their friendship, support and motivation throughout the thesis process.

ABSTRACT

APPLICATION OF DATA ENVELOPMENT ANALYSIS TO CHEMICAL ENGINEERING

Data Envelopment Analysis (DEA) is a method for measuring relative efficiencies of Decision Making Units (DMUs). DEA is used to rank the DMUs according to their relative efficiencies. For the last three decades, there have been incredible numbers of works on DEA and its applications. However, as of today, there is no application of DEA to Chemical Engineering. Hence, this thesis is focused on the applicability of the DEA to Chemical Engineering problems in order to judge its effectiveness, and possibly, to open up new research area particularly in chemical process systems engineering.

In this thesis, two different problems of chemical engineering are solved via DEA by using Constant Returns-to-Scale (CRS) model. One of the problems is the ranking of the efficiencies of the alternative Heat Exchanger Network (HEN) structures, and the other is the ranking of the efficiencies of the alternative flowsheets of the Hydrodealkylation of Acetone (HDA) process. The DEA formulations are developed for both problems firstly by determining the DMUs, inputs, and outputs of the systems. Then, the DEA models are transformed into Linear Programming (LP) problems. The LPs are solved using the Excel Solver. The effects of the addition of value-judgement constraints in the DEA models are also considered.

As a result of this thesis work, it is concluded that if a chemical engineer can clearly define the measure of efficiency and analyzes the relationships among the DMUs, inputs, and outputs, then the DEA is an easily applicable and trustable method to compute and rank the relative efficiencies of the alternative process flowsheets or designs. DEA is also applicable to very large-scale systems with many alternatives (DMUs), and many inputs and outputs since it requires the solution of LPs only.

ÖZET

VERİ ZARFLAMA ANALİZİNİN KİMYA MÜHENDİSLİĞİNE UYGULANMASI

Veri Zarflama Analizi (VZA) Karar Verme Birimlerinin (KVB) göreceli verimliliklerini ölçmek için kullanılan bir yöntemdir. VZA KVB'lerinin göreceli verimliliklerinin sıralanmasında kullanılır. Son otuz yıldır, inanılmaz sayıda VZA ve uygulamalı çalışmaları vardır. Ancak, bugüne kadar, VZA'nın Kimya Mühendisliği uygulaması yoktur. Bu sebeple, bu tez, geçerliliğini görmek ve özellikle kimyasal proses sistemleri mühendisliğinde yeni bir araştırma alanı açabilmek amacıyla, VZA'nın Kimya Mühendisliği problemlerine uygulanabilirliği üzerine odaklanmıştır.

Bu tezde, CRS (Constant Returns-to-Scale) modeli doğrultusunda iki farklı kimya mühendisliği problemi çözülmüştür. Problemlerden biri, alternatif Isı Değiştirici Ağı (IDA) yapılarının verimliliklerinin düzenlenmesi, diğeri ise Asetonun Hidro-di-alkilasyon sürecinin (HDA) alternatif akım şemaları verimliliklerinin düzenlenmesidir. Öncelikle sistemdeki KVB'lerinin, girdilerin ve çıktılarının belirlenmesi ile her iki problem için VZA formülleri geliştirilmiştir. Sonrasında, bu VZA modelleri Doğrusal Programlama (DP) problemlerine dönüştürülmüştür. DP'lar Excel Çözücüsü kullanılarak çözülmüştür. VZA'de değer yargılama kısıtlamalarının etkileri de dikkate alınmıştır.

Bu tez çalışmasının bir sonucu olarak, eğer bir kimya mühendisi verimlilik ölçümünü açıkça tanımlayabilir ve KVB'lerinin girdileri ve çıktıları arasındaki ilişkileri iyi analiz edebilirse; VZA'nın alternatif akım şemalarının ve tasarımlarının göreceli verimliliklerini elde etmek ve sıralamak için kolayca uygulanabilir, güvenilir bir yöntem olduğu anlaşılmıştır. VZA, sadece DP çözümü gerektirmesinden dolayı birçok alternatif KVB ve girdi/çıkıtı içeren çok geniş yelpazeli sistemlerde dahi uygulanabilir.

TABLE OF CONTENTS

ACKNOWLEDGEMENTS	iii
ABSTRACT	iv
ÖZET	v
LIST OF FIGURES	viii
LIST OF TABLES	x
LIST OF SYMBOLS/ABBREVIATIONS	xiv
1. INTRODUCTION	1
2. DATA ENVELOPMENT ANALYSIS	3
2.1. Short Review and Mathematical Formulation of DEA	3
2.2. An Introductory Example: Efficiency of a Chemical Company	7
2.2.1. Graphical Representation	9
2.2.2. Numerical Solution	11
3. APPLICATIONS OF DEA TO CHEMICAL ENGINEERING	16
3.1. Alternative Heat-Exchanger Networks	16
3.1.1. Basic DEA of the HEN Structures	23
3.1.2. DEA of the HEN Structures with Value Judgment Constraints	30
3.1.2.1. Value Judgment with Bound Constraints on Weights	30
3.1.2.2. Value-Judgment with Inequality Constraints on Input Weights ...	33
3.1.2.3 Value-Judgment with Inequality Constraints on Input Weights with Multipliers	36
3.2. Alternative Flowsheets for Hydrodealkylation of Toluene (HDA) Process	39
3.2.1. Basic DEA of HDA Process	45
3.2.2. DEA of the HDA Process with Value Judgment	48
3.2.2.1. Value Judgment with Bound Constraints on Weights	48
3.2.2.2. Value-Judgment with Equality or Inequality Constraints on Input/Output Weights	51
3.2.2.3 Value-Judgment with Inequality Constraints on Output Weights with Multipliers	55
4. CONCLUSIONS AND RECOMMENDATIONS	59

REFERENCES 62
REFERENCES NOT CITED 63

LIST OF FIGURES

Figure 2.1.	Efficient frontier	09
Figure 2.2.	Graphical presentation of relative efficiency of PL 4	11
Figure 3.1.	HEN structures (Konukman et al., 2001)	18
Figure 3.2.	Total utility consumption versus the flexibility ranges of HEN structures (Konukman et al., 2001)	19
Figure 3.3.	Number of process-stream exchangers versus flexibility	20
Figure 3.4.	Number of cold utility exchangers versus flexibility	21
Figure 3.5.	Number of hot utility exchangers versus flexibility	21
Figure 3.6.	Hot utility consumption (kW) versus flexibility	22
Figure 3.7.	Cold utility consumption (kW) versus flexibility	22
Figure 3.8.	Total utility consumption (kW) versus flexibility	23
Figure 3.9.	Flowsheet of the base-case HDA process (Douglas, 1988)	40
Figure 3.10.	Flowsheet alternative 1 for the HDA process (Douglas, 1988)	41
Figure 3.11.	Flowsheet alternative 2 for the HDA process (Douglas, 1988)	41
Figure 3.12.	Flowsheet alternative 3 for the HDA process (Douglas, 1988)	42

Figure 3.13. Flowsheet alternative 4 for the HDA process (Douglas, 1988) 42

Figure 3.14. Flowsheet alternative 5 for the HDA process (Douglas, 1988) 43

LIST OF TABLES

Table 2.1.	Production line input/output data of a chemical company	7
Table 2.2.	Production rates per worker and calculation of relative efficiencies ..	8
Table 2.3.	Production line data with two different products A and B	8
Table 2.4.	Production amount per worker for both A and B	8
Table 2.5.	Relative efficiencies and weights of the production lines	15
Table 3.1.	HEN structures as a result of MILP solutions (Konukman et al., 2001	17
Table 3.2.	Input/output data for the HEN example	24
Table 3.3.	Relative efficiencies and optimal weights of the HENs.....	29
Table 3.4.	Relative efficiencies and optimal weights with the constraint $w \geq$ 0.00001 for the HEN structures	31
Table 3.5.	Relative efficiencies and optimal weights with the constraint $w \geq$ 0.00010 for the HEN structures	31
Table 3.6.	Relative efficiencies and optimal weights with the constraint $w \geq$ 0.000112 for the HEN structures	32
Table 3.7.	Effects of the value judgment constraints as lower bounds	32

Table 3.8.	Relative efficiencies and optimal weights with the constraint $w_{HUC} \geq w_{CUC}$	34
Table 3.9.	Relative efficiencies and optimal weights with the constraint $w_{NHEX} \geq w_{NHU}$	35
Table 3.10.	Relative efficiencies and optimal weights with the constraints $w_{HUC} \geq w_{CUC}$, $w_{NHU} \geq w_{NCU}$, $w_{NHEX} \geq w_{NCU}$, and $w_{NHEX} \geq w_{NHU}$	35
Table 3.11.	Effects of the value judgment inequality constraints	36
Table 3.12.	Relative efficiencies and optimal weights with constraint $w_{NHEX} \geq 2 \times w_{NHU}$	37
Table 3.13.	Relative efficiencies and optimal weights with constraint $w_{NHEX} \geq 3 \times w_{NHU}$	37
Table 3.14.	Relative efficiencies and optimal weights with constraint $w_{NHEX} \geq 30 \times w_{NHU}$	38
Table 3.15.	Effects of the value judgment inequality constraint multipliers	38
Table 3.16.	Properties of the HDA flowsheet alternatives (Douglas, 1988)	43
Table 3.17.	The input/output data for the HDA process alternatives	44
Table 3.18.	Relative efficiencies and the optimal values of the weights for the alternative HDA flowsheets without value-judgment constraints	48
Table 3.19.	Relative efficiencies and optimal weights with the constraint $w \geq 0.00001$ for the alternative HDA flowsheets	49
Table 3.20.	Relative efficiencies and optimal weights with the constraint $w \geq 0.00010$ for the alternative HDA flowsheets	49

Table 3.21.	Relative efficiencies and optimal weights with the constraint $w \geq 0.00100$ for the alternative HDA flowsheets	50
Table 3.22.	Relative efficiencies and optimal weights with the constraint $w \geq 0.003415$ for the alternative HDA flowsheets	50
Table 3.23.	Effects of the value judgment constraints as lower bounds for HDA .	51
Table 3.24.	Relative efficiencies and optimal weights for the alternative HDA flowsheets with value-judgment constraint $w_{TAC} \geq w_{LBS}$	52
Table 3.25.	Relative efficiencies and optimal weights for the alternative HDA flowsheets with value-judgment constraint $w_{TAC} \geq w_{LBS}$	53
Table 3.26.	Relative efficiencies and optimal weights for the alternative HDA flowsheets with value-judgment constraint $w_{RB} = w_{ER}$	53
Table 3.27.	Relative efficiencies and optimal weights for the alternative HDA flowsheets with value-judgment constraints $w_{TAC} \geq w_{LBS}$, $w_{RB} \geq w_{CONV}$, $w_{RB} \geq w_{ER}$	54
Table 3.28.	Effects of the value judgment equality or inequality constraints for HDA	54
Table 3.29.	Relative efficiencies and optimal weights with the constraint $w_{RB} \geq 2 \times w_{ER}$	55
Table 3.30.	Relative efficiencies and optimal weights with the constraint $w_{RB} \geq 10 \times w_{ER}$	56
Table 3.31.	Relative efficiencies and optimal weights with the constraint $w_{RB} \geq 100 \times w_{ER}$	56

Table 3.32.	Effects of the value judgment inequality constraint multipliers	57
-------------	---	----

LIST OF SYMBOLS/ABBREVIATIONS

E_{PL}	The Efficiency of Production Line
x	Amount of Input
w	The Weight
y	Amount of Output
δ	Flexibility Index
BCC	Banker-Charnes-Cooper
CCR	Charnes-Cooper-Rhodes
CONV	Conversion
CRS	Constant Returns-to-Scale
CU	Number of Cooling Units
CUC	Cooling Utility Consumption
DEA	Data Envelopment Analysis
DMU	Decision Making Unit
ER	Energy Recovery
FDH	Free Disposal Hull
HDA	Hydrodealkylation of Toluene
HEN	Heat Exchanger Network
HEX	Number of Heat Exchangers
HU	Number of Heating Units
HUC	Heating Utility Consumption
LBS	Loss of Benzene
LP	Linear Programming
NU	Number of Units
PA	Product A
PB	Product B
PL	Production Line
RAM	Range Adjusted Measure
RB	Recovery of Benzene

TAC	Total Annual Cost
VJ	Value-Judgment
VRS	Variable Returns-to-Scale

1. INTRODUCTION

Organizations always want to measure efficiencies to improve their current situation. However, generally there are too many criteria to evaluate the efficiencies of units in organizations. Data Envelopment Analysis (DEA) is a method for measuring the relative efficiencies of units in various contexts. It is used to determine the relatively most efficient Decision Making Unit (DMU) and the efficiencies of other units relative to it. Especially for the last three decades, there have been many researches and applications of DEA for different organizations such as schools, hospitals, militaries, banks, factories, etc. (Cooper, Seiford and Zhu, 2004) One of the reasons to use DEA is its simplicity of usage in cases which have been resistant to other approaches because of the complex nature of relations between multiple inputs and multiple outputs encountered in most of the real-life situations. Some of the DEA applications evaluate the performances of cities, regions, countries, and firms, with many different kinds of inputs and outputs; supplying new insights into activities that have previously been studied by other methods. For example, studies of benchmarking practices with DEA have identified numerous sources of inefficiency in some of the most profitable firms. The use of DEA has suggested reconsideration of previous studies of the efficiency (Cooper, Seiford and Zhu, 2004). The studies with DEA can be used to show not only how new results can be secured but also to show some of the new methods of data exploitation that DEA makes available.

In the literature, there are basically two models for DEA. The first one is Charnes-Cooper-Rhodes (CCR) model (Charnes *et al.*, 1978) based on the “constant returns-to-scale” approximation and the second one is Banker-Charnes-Cooper (BCC) model (Banker *et al.*, 1984) considering the “variable returns-to-scale”. In this thesis, the CCR model is used to apply the DEA to Chemical Engineering problems. In the CCR model it is assumed that the DMUs are homogeneous, the relation between the inputs and outputs is monotone, and the data for employing DEA are accurate.

Even though there are many interesting studies carried out with DEA in other disciplines, there is no application of DEA to Chemical Engineering. Hence, this study is

focused on the application of DEA to some Chemical Engineering problems in order to judge its effectiveness, and possibly, to open up new research area in process systems engineering.

The outline of this thesis is as follows. In the second chapter, the DEA subject is reviewed and its mathematical formulations are presented. In this chapter a simple chemical plant example is also presented and discussed. In the third chapter, two chemical engineering applications of DEA are presented. One of these applications deals with heat exchanger networks and the second deals with alternative flowsheet proposals for hydrodealkylation of toluene process. In the fourth chapter, there are the conclusions and recommendations for future studies.

2. DATA ENVELOPMENT ANALYSIS

This chapter will present some approaches and the basic Data Envelopment Analysis (DEA) models commonly used. A formulation of DEA in its basic form and a simple chemical plant example to clarify the properties of DEA will be given. The mathematical and graphical solutions of the example will be presented. First, the input and outputs of the chemical plant example are defined, Linear Programming (LP) formulations are shown step by step, and then solution of the problem using the Excel Solver is explained.

2.1. A Short Review and Mathematical Formulation of DEA

The first appearance of DEA was in 1978 with the work of Charnes, Cooper and Rhodes (Charnes *et al.*, 1978). Since then, both theoretical works and applications to practical situations grew tremendously (Cook and Seiford, 2009). With this growth, the number of DEA models has increased too. DEA requires assumptions. The ability to alter, test, and select assumptions are essential in conducting DEA-based research. The DEA models currently available offer a limited variety of alternative assumptions. The well known DEA models are listed below (Cook and Seiford, 2009).

- The constant returns-to-scale model (CRS)
- The variable returns-to-scale model (VRS)
- The additive model
- Slacks-based measures
- The Russell measure
- Range-adjusted measure (RAM)
- The free-disposal Hull model (FDH)
- Multistage/serial models (network and supply chains)
- Multicomponent/parallel models

- Hierarchical/nested models

It is the easiest way to compare efficiencies of Decision Making Units (DMUs) in a single input and output situation by the simple ratio method. This ratio is;

$$Efficiency = \frac{Output}{Input} \quad (2.1)$$

When the number of inputs and outputs increase some assumptions should be made to create a reasonable efficiency-comparison formulation. At that point, the DEA is the most common tool to evaluate the efficiencies of the DMUs by relative comparison.

In DEA, the comparison is not theoretical or absolute; it is a relative measurement of the efficiencies, choosing the best unit as the excellent unit with 100 per cent efficiency. It is the main point of DEA to choose the set of comparable DMUs. The DMUs should exhibit best practice and should be identified to form an efficient frontier. The basic DEA formulation can be cast into a LP problem.

Basically, to create a DEA for a situation; one should select and collect data that are reasonable and satisfactory to form relative measurements. The data can be defined as input and output for the DMUs. Then, the model should be created by formulating with the restrictions and constraints of the system.

The case to measure the relative efficiency, where there are multiple --possibly disproportionate-- inputs and outputs, was addressed by Farrell (1957) and developed by Farrell and Fieldhouse (1962) by focusing on the construction of a hypothetical efficient unit as a weighted average of efficient units to act as a comparator for an inefficient unit. A common measure for relative efficiency is;

$$\text{Efficiency} = \frac{\text{Weighted Sum of Outputs}}{\text{Weighted Sum of Inputs}} \quad (2.2)$$

which can be written as:

$$\text{Efficiency of unit } j = \frac{w_{O_1} y_{1j} + w_{O_2} y_{2j} + \dots}{w_{I_1} x_{1j} + w_{I_2} x_{2j} + \dots} \quad (2.3)$$

where;

w_{O_1} : the weight given to output 1

y_{1j} : amount of output 1 from unit j

w_{I_1} : the weight given to input 1

x_{1j} : amount of input 1 to unit j

Efficiency is usually constrained to the range [0, 1].

The initial assumption is that this measure of efficiency requires a common set of weights to be applied across all units. Charnes *et al.* (1978) recognized the difficulty in seeking a common set of weights to determine relative efficiency. They recognized the legitimacy of the proposal that units might value inputs and outputs differently and therefore adopt different weights, and proposed that each unit should be allowed to adopt a set of weights which shows it in the most favorable light in comparison to the other units. Under these circumstances, efficiency of a target unit j_0 can be obtained as a solution to the following problem: Maximize the efficiency of unit j_0 , subject to the efficiency of all units being less than or equal to 1.

The variables of the above problem are the input and output weights. The solution produces the weights most favorable to unit j_0 and also produces a measure of efficiency.

The corresponding algebraic model is as follows:

$$max = \frac{\sum_o w_o y_{oj_0}}{\sum_i w_i x_{ij_0}}$$

subject to

$$\frac{\sum_o w_o y_{oj}}{\sum_i w_i x_{ij}} \leq 1 \text{ for } \forall j. \quad (2.4)$$

$$w_o, w_i \geq \epsilon \quad (2.5)$$

Where “o” is the index for the outputs and “i” is the index for the inputs.

The above DEA model is a fractional nonlinear-programming problem. To solve the model it is first necessary to convert it into linear form so that the methods of LP can be applied. The linearization process is relatively straightforward. The linear version of the constraints of above presentation is shown below. For the objective function it is necessary to observe that in maximizing a fraction or ratio, it is the relative magnitude of the numerator and denominator that are of interest, not their individual values. It is thus possible to achieve the same effect by setting the denominator equal to a constant and maximizing the numerator. The resulting LP is as follows:

$$max \sum_o w_o y_{oj_0}$$

subject to

$$\sum_i w_i x_{ij_0} = 1 \quad (2.6)$$

$$\sum_o w_o y_{oj} - \sum_i w_i x_{ij} \leq 0 \quad j=1, 2, \dots, n. \quad (2.7)$$

$$w_o, w_i \geq \epsilon \quad (2.8)$$

In the DEA literature, input-oriented and output-oriented calculations of efficiency are identical for the constant returns-to-scale (CRS) model. If this equality does not exist for every input-output range, it is understood that it is explained by variable returns-to-scale (VRS) model.

2.2. An Introductory Example: Efficiency of a Chemical Company

The example and associated numerical values used in this section were adopted from Beasley's example that measures the efficiency of bank branches and adapted to chemical engineering.

It is easy to compare the efficiency of the workers or the production lines in a chemical company if there is only one input and only one output. For example; if the company has four production lines (PL) and if product A (PA) is produced by workers, then it is easy to calculate the efficiency of workers only by dividing the produced amount with the number of workers. PLs are the DMUs of this example while the number of workers is the input and the amount of PA produced is the output.

Table 2.1. Production line input/output data of a chemical company

DMU	Output	Input	PA per Worker
Production Line	Amount of Product A	Number of Workers	
PL 1	125	18	6.94
PL 2	44	16	2.75
PL 3	80	17	4.71
PL 4	23	11	2.09

Since PL1 is the most efficient one among the four production lines (PA per worker value of 6.94 is the highest ratio), it will have 100 per cent relative efficiency and the others will be calculated based on that.

Table 2.2. Production rates per worker and calculation of relative efficiencies

Production Line	PA per Worker	Calculation of Relative Efficiencies	Relative Efficiencies
PL 1	6.94	$100 \times (6.94/6.94)$	100 %
PL 2	2.75	$100 \times (2.75/6.94)$	40 %
PL 3	4.71	$100 \times (4.71/6.94)$	68 %
PL 4	2.09	$100 \times (2.09/6.94)$	30 %

If the example is enlarged with an additional product; there will be two output measures; amount of Product A (PA) produced and amount of Product B (PB) produced and one input measure; number of workers. The table will then become;

Table 2.3. Production line data with two different products A and B

DMU	Outputs		Input
Production Line	Amount of Product A	Amount of Product B	Number of Workers
PL 1	125	50	18
PL 2	44	20	16
PL 3	80	55	17
PL 4	23	12	11

Then the solution will depend on the product produced.

Table 2.4. Production amount per worker for both A and B

Production Line	PA per Worker	PB per Worker
PL 1	6.94	2.78
PL 2	2.75	1.25
PL 3	4.71	3.24
PL 4	2.09	1.09

If we compare the lines according to produced amount of PA, PL 1 is the most efficient DMU. On the other hand, when we compare them according to amount of PB, PL 3 is the most efficient DMU. Thus, as demonstrated here, it is not always straightforward to combine these ratios into a one final judgment.

2.2.1. Graphical Representation

Since there are two outputs and one input, the data can be analyzed on a two-dimensional graphical representation of the amount of PA produced per worker versus amount of PB produced per worker.

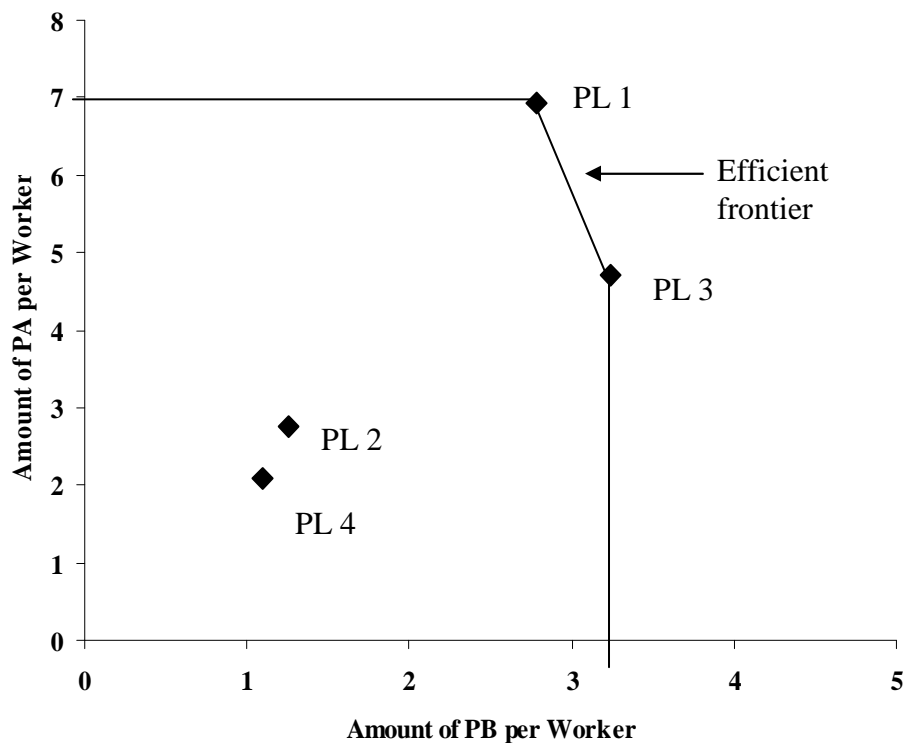

Figure 2.1. Efficient frontier

The positions on the graph represented by PL 1 and PL 3 demonstrate a level of performance which is superior to all other branches. A horizontal line is drawn, from the y-axis to PL 1, from PL 1 to PL 3, and a vertical line from PL 3 to the x-axis as shown on Figure 2.1. This line is called the “efficient frontier”.

To exemplify the relative efficiency, here the current performance of PL 4 (the length of the line from the origin to PL 4) is compared to the best possible performance that PL 4 could reasonably be expected to achieve (the length of the line from the origin through PL 4 to the efficient frontier) as shown on Figure 2.2. In DEA, the relative efficiency of PL 4 is numerically measured by the dividing the length of the line from origin to PL 4 to the length of line from origin through PL 4 to the efficient frontier. For PL 4 this is an efficiency of 36 per cent.

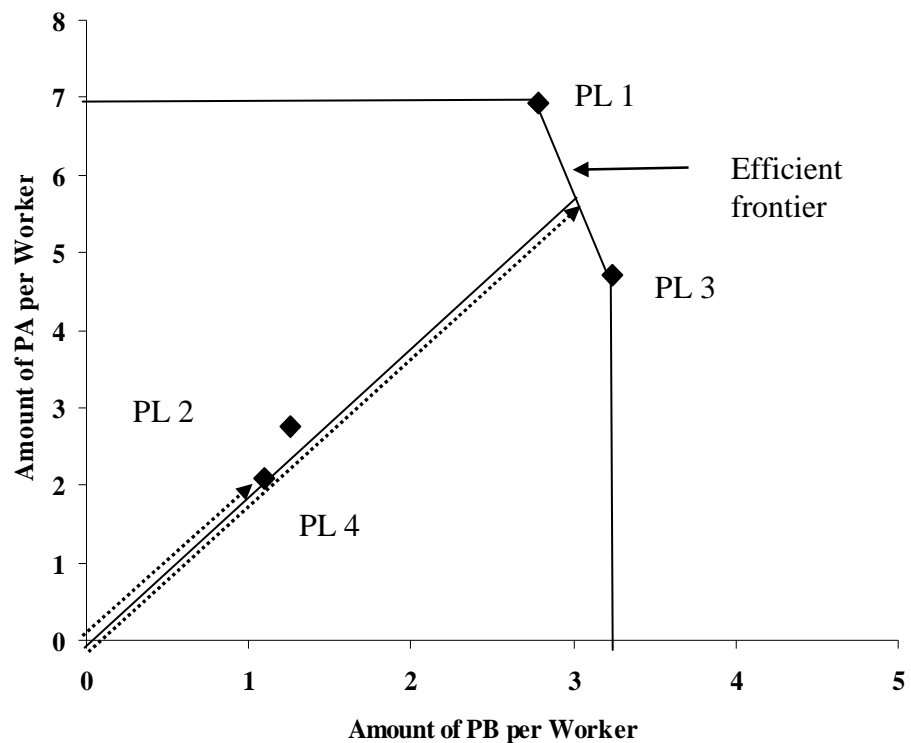

Figure 2.2. Graphical presentation of relative efficiency of PL 4

2.2.2. Numerical Solution

It is not possible to use graphics to measure the relative efficiencies for more than totally three inputs and outputs. Under such high-dimensional cases one should calculate the relative efficiencies using mathematics. Hence, one needs to specify the weights for each input and output to be able to maximize their efficiencies. The relative efficiencies of DMUs are;

$$E_{PL1} = (125w_{PA} + 50w_{PB}) / (18w_{worker}) \quad (2.9)$$

$$E_{PL2} = (44w_{PA} + 20w_{PB}) / (16w_{worker}) \quad (2.10)$$

$$E_{PL3} = (80w_{PA} + 55w_{PB}) / (17w_{worker}) \quad (2.11)$$

$$E_{PL4} = (23w_{PA} + 12w_{PB}) / (11w_{worker}) \quad (2.12)$$

with the limitations;

$$0 \leq E_{PL1} \leq 1 \quad (2.13)$$

$$0 \leq E_{PL2} \leq 1 \quad (2.14)$$

$$0 \leq E_{PL3} \leq 1 \quad (2.15)$$

$$0 \leq E_{PL4} \leq 1 \quad (2.16)$$

and,

$$w_{PA}, w_{PB}, w_{worker} \geq 0 \quad (2.17)$$

where;

E_{PL1} is the efficiency of production line 1,

E_{PL2} is the efficiency of production line 2,
 E_{PL3} is the efficiency of production line 3,
 E_{PL4} is the efficiency of production line 4,
 w_{PA} is the weight attached to product A,
 w_{PB} is the weight attached to product B,
 w_{worker} is the weight attached to number of workers.

The aim is to maximize the relative efficiency of each DMU one by one. The problem is still a nonlinear problem. It can be converted into a LP problem firstly by expressing equations from 2.13 to 2.16 in terms of weights and then by introducing additional constraint for the denominator of the objective function to be equal to one and thus linearize the constraints as well.

For PL 1;

Equations from 2.9 to 2.12 can be inserted into equations 2.13 and 2.16 respectively. Thus, the original non-linear (fractional) optimization model is as follows;

$$\text{maximize} \quad \frac{125w_{PA} + 50w_{PB}}{18w_{worker}}$$

subject to;

$$0 \leq \frac{125w_{PA} + 50w_{PB}}{18w_{worker}} \leq 1 \quad (2.18)$$

$$0 \leq \frac{44w_{PA} + 20w_{PB}}{16w_{worker}} \leq 1 \quad (2.19)$$

$$0 \leq \frac{80w_{PA} + 55w_{PB}}{17w_{worker}} \leq 1 \quad (2.20)$$

$$0 \leq \frac{23w_{PA} + 12w_{PB}}{11w_{worker}} \leq 1 \quad (2.21)$$

$$w_{PA}, w_{PB}, w_{worker} \geq 0 \quad (2.22)$$

The linear form of this model is given as follows;

$$\begin{aligned} \text{maximize} & \quad 125w_{PA} + 50w_{PB} \\ \text{subject to:} & \\ & 18w_{worker} = 1 \end{aligned} \quad (2.23)$$

$$(125w_{PA} + 50w_{PB}) - 18w_{worker} \leq 0 \quad (2.24)$$

$$(44w_{PA} + 20w_{PB}) - 16w_{worker} \leq 0 \quad (2.25)$$

$$(80w_{PA} + 55w_{PB}) - 17w_{worker} \leq 0 \quad (2.26)$$

$$(23w_{PA} + 12w_{PB}) - 11w_{worker} \leq 0 \quad (2.27)$$

$$w_{PA}, w_{PB}, w_{worker} \geq 0 \quad (2.28)$$

For PL 2;

The linearized model is as follows;

$$\begin{aligned} \text{maximize} & \quad 44w_{PA} + 20w_{PB} \\ \text{subject to:} & \\ & 16w_{worker} = 1 \end{aligned} \quad (2.29)$$

$$(125w_{PA} + 50w_{PB}) - 18w_{worker} \leq 0 \quad (2.30)$$

$$(44w_{PA} + 20w_{PB}) - 16w_{worker} \leq 0 \quad (2.31)$$

$$(80w_{PA} + 55w_{PB}) - 17w_{worker} \leq 0 \quad (2.32)$$

$$(23w_{PA} + 12w_{PB}) - 11w_{worker} \leq 0 \quad (2.33)$$

$$w_{PA}, w_{PB}, w_{worker} \geq 0 \quad (2.34)$$

For PL 3;

The linearized model is as follows;

$$\text{maximize} \quad 80w_{PA} + 55w_{PB}$$

subject to:

$$17w_{\text{worker}} = 1 \quad (2.35)$$

$$(125w_{\text{PA}} + 50w_{\text{PB}}) - 18w_{\text{worker}} \leq 0 \quad (2.36)$$

$$(44w_{\text{PA}} + 20w_{\text{PB}}) - 16w_{\text{worker}} \leq 0 \quad (2.37)$$

$$(80w_{\text{PA}} + 55w_{\text{PB}}) - 17w_{\text{worker}} \leq 0 \quad (2.38)$$

$$(23w_{\text{PA}} + 12w_{\text{PB}}) - 11w_{\text{worker}} \leq 0 \quad (2.39)$$

$$w_{\text{PA}}, w_{\text{PB}}, w_{\text{worker}} \geq 0 \quad (2.40)$$

For PL 4;

The linearized model is as follows;

maximize

$$23w_{\text{PA}} + 12w_{\text{PB}}$$

subject to:

$$11w_{\text{worker}} = 1 \quad (2.41)$$

$$(125w_{\text{PA}} + 50w_{\text{PB}}) - 18w_{\text{worker}} \leq 0 \quad (2.42)$$

$$(44w_{\text{PA}} + 20w_{\text{PB}}) - 16w_{\text{worker}} \leq 0 \quad (2.43)$$

$$(80w_{\text{PA}} + 55w_{\text{PB}}) - 17w_{\text{worker}} \leq 0 \quad (2.44)$$

$$(23w_{\text{PA}} + 12w_{\text{PB}}) - 11w_{\text{worker}} \leq 0 \quad (2.45)$$

$$w_{\text{PA}}, w_{\text{PB}}, w_{\text{worker}} \geq 0 \quad (2.46)$$

Using Excel Solver with ‘Assume Non-Negative’ and ‘Assume Linear Model’ choices selected, and with the “Precision” parameter of 10^{-6} , the corresponding relative efficiencies for all DMUs and weights of the input and outputs are found by solving the LPs for all the DMUs individually on different Excel worksheets.

Table 2.5. Relative efficiencies and weights of the production lines

DMU	Efficiency	W_{PA}	W_{PB}	W_{worker}
PL 1	1.00	0.00271	0.01324	0.05556
PL 2	0.43	0.00304	0.01489	0.06250
PL 3	1.00	0.00286	0.01402	0.05882
PL 4	0.36	0.00443	0.02166	0.09091

As a result, PL 1 and PL 3 have the highest efficiency with respect to the others and therefore they are on the efficient frontier. This means that they have 100 per cent efficiencies. PL 2 has 43 per cent and PL 4 has 36 per cent efficiency relative to PL1 and PL 3. As seen from Table 2.5, the weights can be different for each DMU as a result of the optimal solution of the corresponding LP.

3. APPLICATIONS OF DEA TO CHEMICAL ENGINEERING

There are different kinds of applications of DEA in different areas, as seen in the literature up to the current day (Beasley, 1996). However, there is no any application of DEA to chemical engineering and process-synthesis problems. Hence, this thesis is on the efficiency ranking in chemical engineering applications via DEA. One of the examples will be the efficiency ranking of alternative Heat-Exchanger Networks (HENs) and the other example will be the efficiency ranking of alternative flowsheets for the Hydrodealkylation of Acetone (HDA) process. For both of the examples, related inputs, outputs and DMUs will be identified, and the LP formulations will be derived. Their relative efficiencies under value-judgment (VJ) constraints will also be presented.

3.1. Alternative Heat-Exchanger Networks

The first application of DEA deals with HENs. Konukman *et al.* (2001) developed an MILP formulation for the synthesis of minimum-utility HEN structures possessing a desired operational flexibility. This formulation is a single-stage, non-iterative, superstructure-based and simultaneous. Using a well-known HEN superstructure, the formulation is solved successively for the fixed values of the flexibility target, δ (\pm directed deviations in source-stream temperatures), ranging from $\delta=0$ to $\delta=150$ K. The results are tabulated in Figure 3.1.

Table 3.1. HEN structures as a result of MILP solutions (Konukman *et al.*, 2001)

Flexibility (δ , K)	Structure	Nominal Total Utility Consumptions		
		Hot kW	Cold kW	Total kW
36.95	A	450	2100	2550
70.63	B1	1050	2700	3750
70.63	B2	1050	2700	3750
70.63	B3	1050	2700	3750
74.24	B4	1050	2700	3750
74.24	B5	1050	2700	3750
90.00	B6	1050	2700	3750
90.00	B7	1050	2700	3750
91.51	C1	1300	2950	4250
120.00	C2	1300	2950	4250
150.00	D	3600	5250	8850

Since some of the HENs possess the same values for δ , for this study the HEN structures are renamed as follows;

Structure A : Structure A
 Structure B1, B2, B3 : Structure B
 Structure B4, B5 : Structure C
 Structure B6 : Structure D
 Structure B7 : Structure E
 Structure C1 : Structure F
 Structure C2 : Structure G
 Structure D : Structure H

The diagrams of these HEN structures are presented in Figure 3.1.

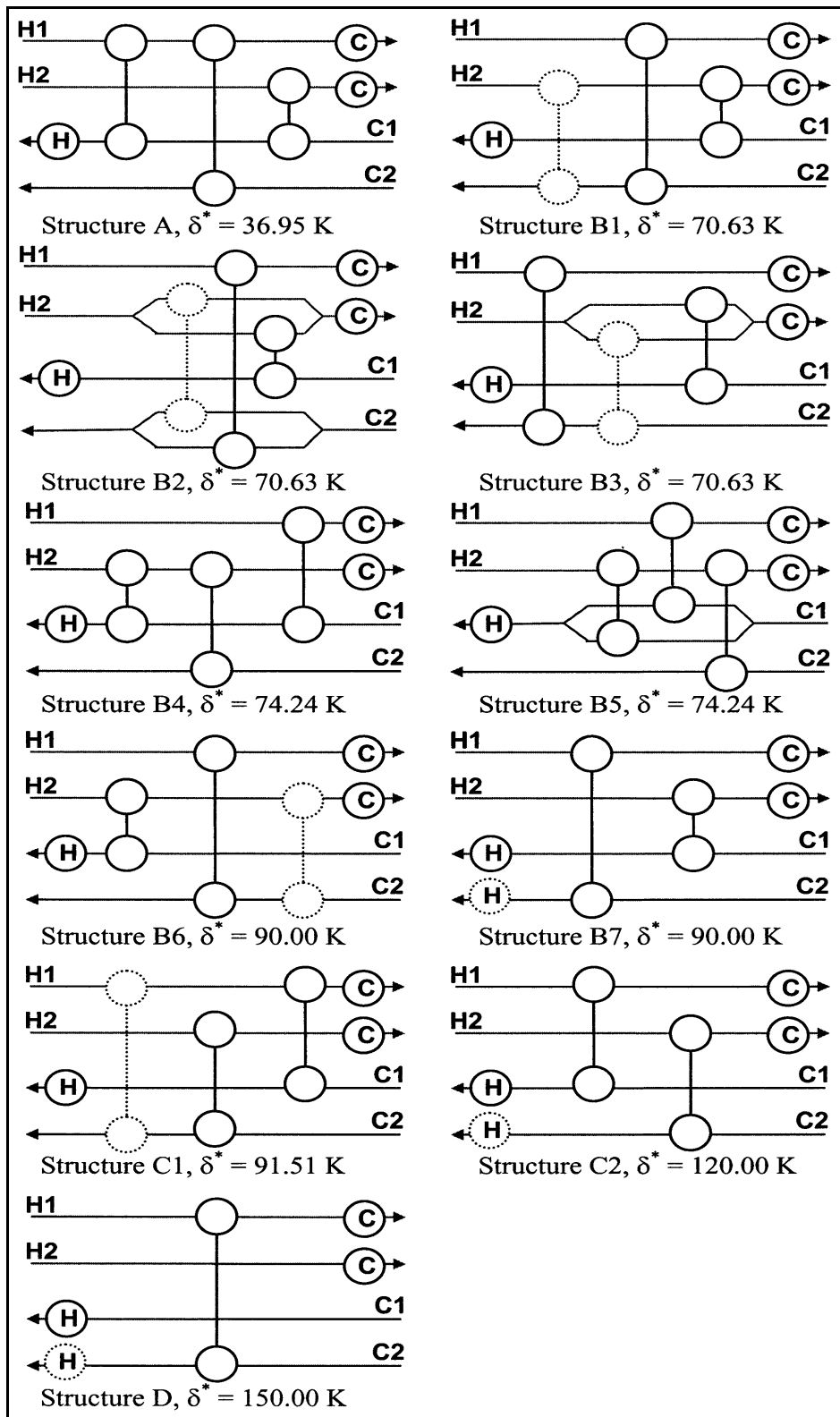
Figure 3.1. HEN structures (Konukman *et al.*, 2001)

Konukman *et al.* (2001) compares the HEN alternatives based on their total utility consumptions and flexibilities as seen in Fig. 3.2, below.

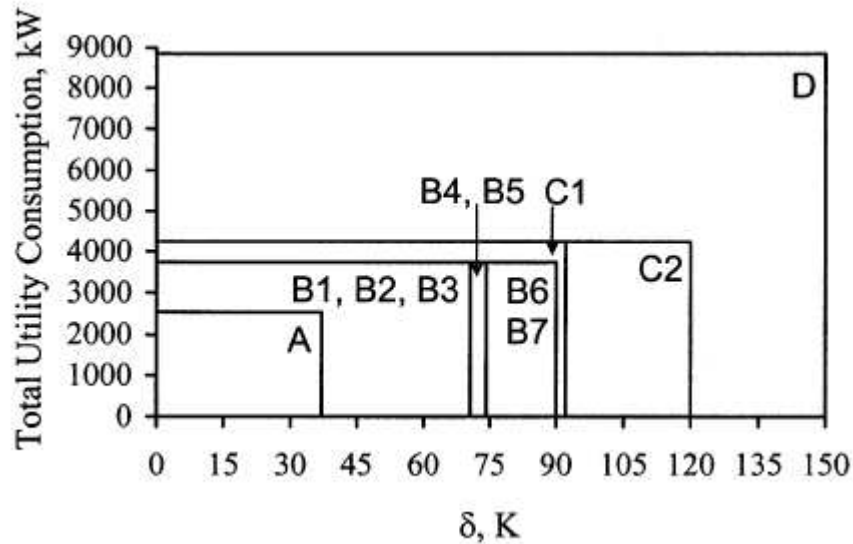

Figure 3.2. Total utility consumption versus the flexibility ranges of HEN structures (Konukman *et al.*, 2001)

Eight different structures, shown in Figure 3.1 (Konukman *et al.*, 2001), are considered as the DMUs. The inputs are the “number of heat exchangers”, “number of heating units”, “number of cooling units”, “heating utility consumption”, “cooling utility consumption”, and the output is the “flexibility index” as given in Table 3.1 (Konukman *et al.*, 2001). It is desirable for the HEN to be selected to have high flexibility to operate under feed-stream temperature disturbances. Therefore, flexibility, δ , is the output of the DMUs (alternative HEN structures). Each HEN has a certain flexibility limit, beyond which the HEN can not operate. The number of heat exchangers, number of heating units, and number of cooling units, heating utility requirement, and cooling utility requirement all affect the resulting flexibility of the HEN. The aim of the efficiency ranking of the alternative HENs is to be able to identify the HEN structure that has the highest flexibility per number of heat exchangers, number of heating units, number of cooling units, heating utility requirement, and cooling utility requirement; all considered simultaneously. If each input is considered mutually exclusively, then one must examine the following figures

(Figure 3.3 to Figure 3.8) for each input individually. For example, if the number of process exchangers is the only input that is cared for, then according to Fig. 3.3 the HEN structure H is the most efficient one since with only one process stream matches (process exchangers) it will show a flexibility of 150 K (it can tolerate +/- 150 K deviations in the hot and cold source stream temperatures). If the number of cold utility exchangers is the only input that is cared for, then according to Fig. 3.4 the HEN structure H is the most efficient one since with only one cold utility exchanger it will show a flexibility of 150 K. If the number of hot utility exchangers is the only input that is cared for, then according to Fig. 3.5 the HEN structure F is the most efficient one since with only one hot utility exchanger it will show a flexibility of 91.51 K. If the hot utility consumption is the only input that is cared for, then according to Fig. 3.6 the HEN structure A is the most efficient one since with 450 kW it will show a flexibility of 36.95 K. If the cold utility consumption is the only input that is cared for, then according to Fig. 3.7 the HEN structure A is the most efficient one since with 2,100 kW it will show a flexibility of 36.95 K. If the total consumption is the only input that is cared for, then according to Fig. 3.8 the HEN structure A is the most efficient one since with 2,550 kW it will show a flexibility of 36.95 K.

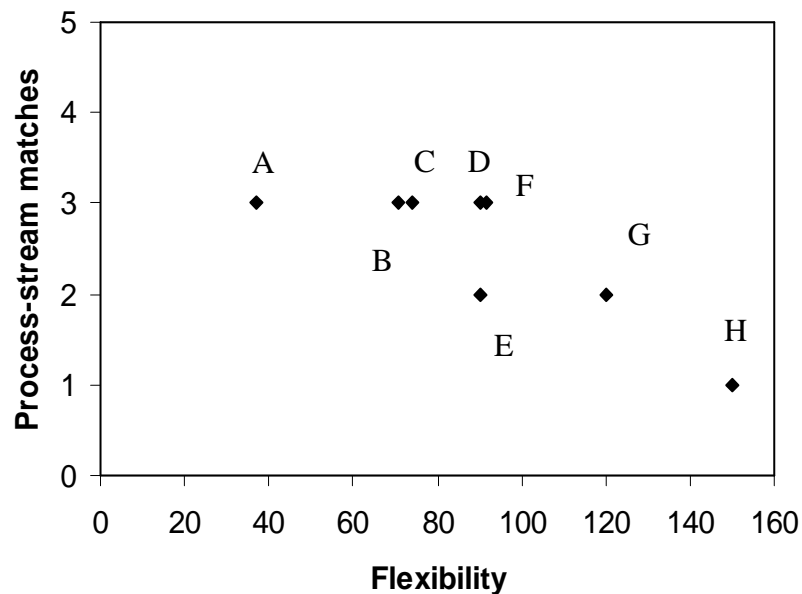

Figure 3.3. Number of process-stream exchangers versus flexibility

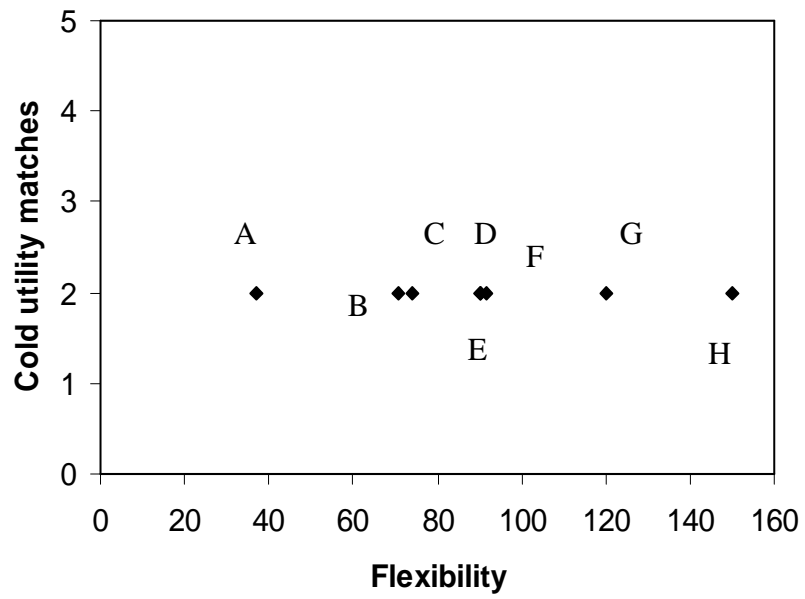

Figure 3.4. Number of cold utility exchangers versus flexibility

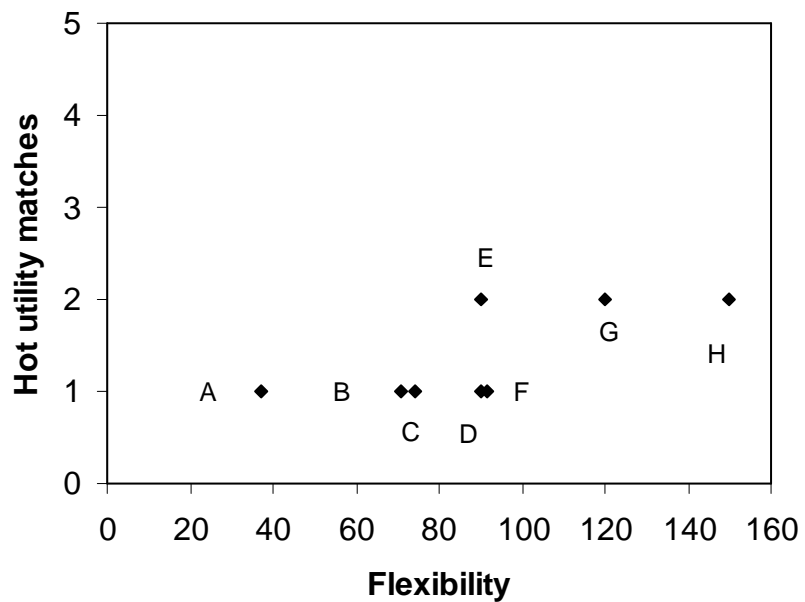

Figure 3.5. Number of hot utility exchangers versus flexibility

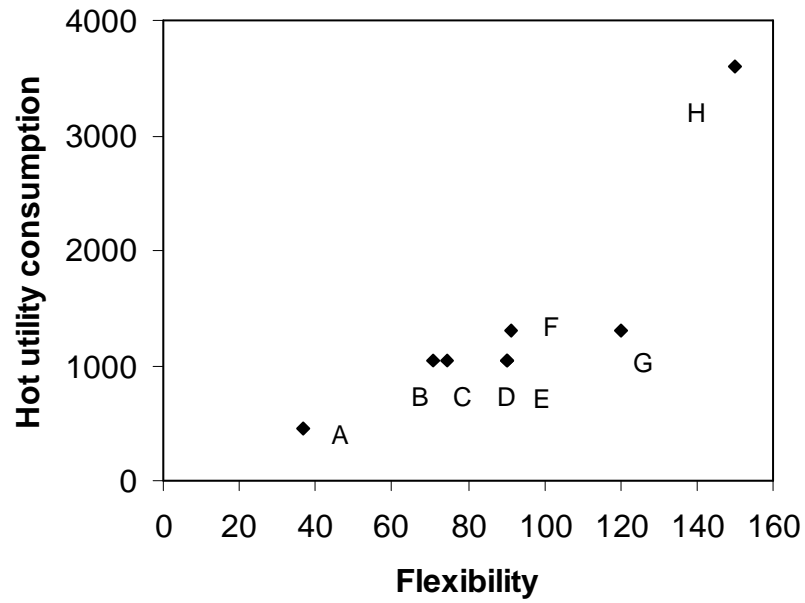

Figure 3.6. Hot utility consumption (kW) versus flexibility

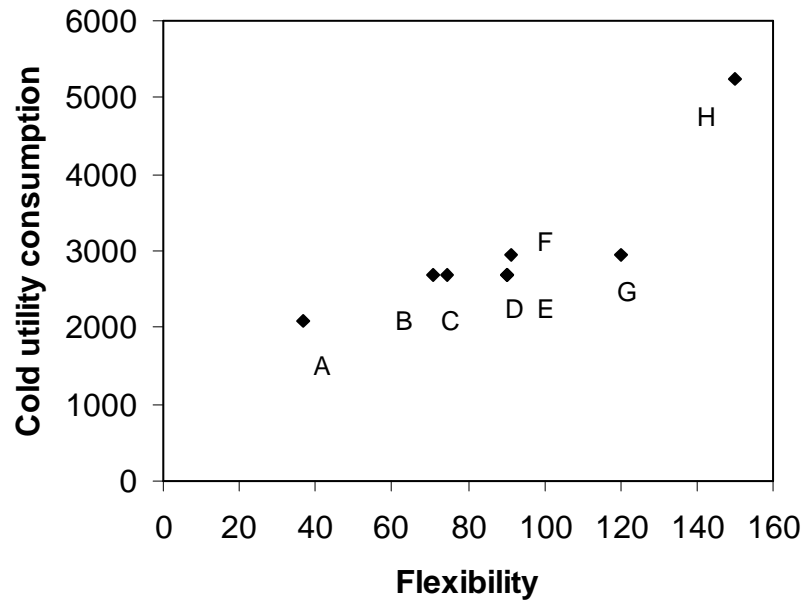

Figure 3.7. Cold utility consumption (kW) versus flexibility

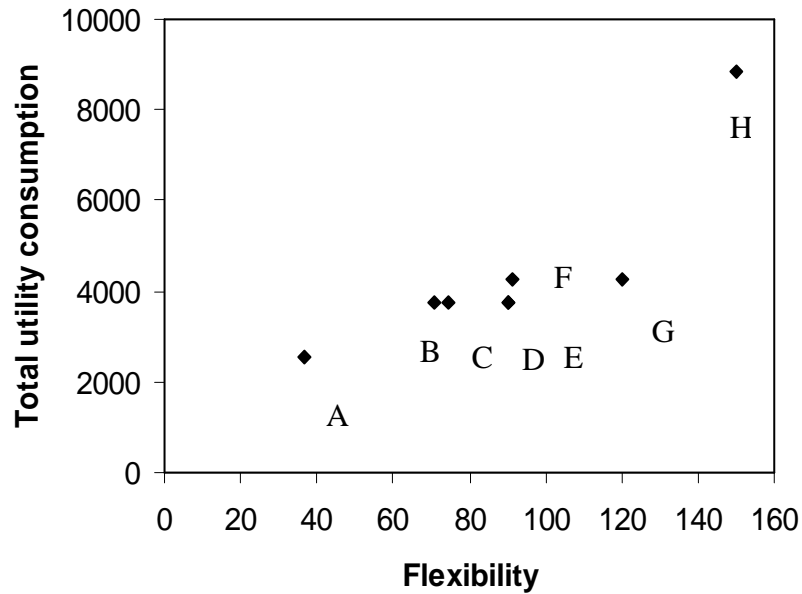

Figure 3.8. Total utility consumption (kW) versus flexibility

As it can be easily understood, it is not an easy task to find the best efficient structure by looking at the figures for each input independently from each other. While one of the structures is good when considering a particular input, the other structure may be good when considering another input. The DEA enables one to rank efficiencies of units (HENs) under multi input multi output situations, as will be demonstrated next.

3.1.1. Basic DEA of the HEN Structures

The selection of the best choice can be determined by using the DEA method. The first step is the identification of inputs and outputs.

Inputs: Number of heat exchangers (HEX)

Number of heating units (HU)

Number of cooling units (CU)

Heating utility consumption (HUC) [kW]

Cooling utility consumption (CUC) [kW]

Output: Flexibility index

The input/output data for eight DMUs (eight HEN structures) are tabulated below:

Table 3.2. Input/output data for the HEN example

DMU	Inputs					Output
HEN Structure	No of HEX	No of HU	No of CU	HUC	CUC	Flex. index
A	3	1	2	450	2100	36.95
B	3	1	2	1050	2700	70.63
C	3	1	2	1050	2700	74.24
D	3	1	2	1050	2700	90.00
E	2	2	2	1050	2700	90.00
F	3	1	2	1300	2950	91.51
G	2	2	2	1300	2950	120.00
H	1	2	2	3600	5250	150.00

For all the inputs and outputs, weights are assigned as w_{NHEX} , w_{NHU} , ..., w_{Flex} in the sequence given in the table above. That is,

w_{NHEX} is the weight for the input: The “number of heat exchangers”,

w_{NHU} is the weight for the input: The “number of heating units”,

w_{NCU} is the weight for input: The “number of cooling units”,

w_{HUC} is the weight for the input: The “heating utility consumption”,

w_{CUC} is the weight for the input: The “cooling utility consumption”,

w_{Flex} is the weight for output: The “flexibility index”.

The next step is the LP formulation for each DMU (HEN structures). Here, it will be shown that how the LP formulation is created with only one DMU, for structure A. The objective function is the relative efficiency of unit A (HEN structure A), which is the ratio

of its weighted outputs to its weighted inputs. Since the weighted input of the focus unit, in this case A, is taken as equal to 1, the objective function reduces to weighted output of A. The other constraints are due to the efficiency definitions for other units (other HEN structures). Additionally, all the weight values are to be positive.

The LP formulation for DMU A is;

$$\text{maximize } 36.95w_{\text{Flex}}$$

subject to:

$$3w_{\text{NHEX}}+w_{\text{NHU}}+2w_{\text{NCU}}+450w_{\text{HUC}}+2100w_{\text{CUC}} = 1 \quad (3.1)$$

$$36.95w_{\text{Flex}} - (3w_{\text{NHEX}}+w_{\text{NHU}}+2w_{\text{NCU}}+450w_{\text{HUC}}+2100w_{\text{CUC}}) \leq 0 \quad (3.2)$$

$$70.63w_{\text{Flex}} - (3w_{\text{NHEX}}+w_{\text{NHU}}+2w_{\text{NCU}}+1050w_{\text{HUC}}+2700w_{\text{CUC}}) \leq 0 \quad (3.3)$$

$$74.24w_{\text{Flex}} - (3w_{\text{NHEX}}+w_{\text{NHU}}+2w_{\text{NCU}}+1050w_{\text{HUC}}+2700w_{\text{CUC}}) \leq 0 \quad (3.4)$$

$$90.00w_{\text{Flex}} - (3w_{\text{NHEX}}+w_{\text{NHU}}+2w_{\text{NCU}}+1050w_{\text{HUC}}+2700w_{\text{CUC}}) \leq 0 \quad (3.5)$$

$$90.00w_{\text{Flex}} - (2w_{\text{NHEX}}+2w_{\text{NHU}}+2w_{\text{NCU}}+1050w_{\text{HUC}}+2700w_{\text{CUC}}) \leq 0 \quad (3.6)$$

$$91.51w_{\text{Flex}} - (3w_{\text{NHEX}}+w_{\text{NHU}}+2w_{\text{NCU}}+1300w_{\text{HUC}}+2950w_{\text{CUC}}) \leq 0 \quad (3.7)$$

$$120.0w_{\text{Flex}} - (2w_{\text{NHEX}}+2w_{\text{NHU}}+2w_{\text{NCU}}+1300w_{\text{HUC}}+2950w_{\text{CUC}}) \leq 0 \quad (3.8)$$

$$150.0w_{\text{Flex}} - (2w_{\text{NHEX}}+2w_{\text{NHU}}+2w_{\text{NCU}}+3600w_{\text{HUC}}+5250w_{\text{CUC}}) \leq 0 \quad (3.9)$$

$$w_{\text{NHEX}}, w_{\text{NHU}}, w_{\text{NCU}}, w_{\text{HUC}}, w_{\text{CUC}}, w_{\text{Flex}} \geq 0 \quad (3.10)$$

LP formulation for DMU B is;

$$\text{maximize } 70.63w_{\text{Flex}}$$

subject to:

$$3w_{\text{NHEX}}+w_{\text{NHU}}+2w_{\text{NCU}}+1050w_{\text{HUC}}+2700w_{\text{CUC}} = 1 \quad (3.11)$$

$$36.95w_{\text{Flex}} - (3w_{\text{NHEX}}+w_{\text{NHU}}+2w_{\text{NCU}}+450w_{\text{HUC}}+2100w_{\text{CUC}}) \leq 0 \quad (3.12)$$

$$70.63w_{\text{Flex}} - (3w_{\text{NHEX}}+w_{\text{NHU}}+2w_{\text{NCU}}+1050w_{\text{HUC}}+2700w_{\text{CUC}}) \leq 0 \quad (3.13)$$

$$74.24w_{\text{Flex}} - (3w_{\text{NHEX}}+w_{\text{NHU}}+2w_{\text{NCU}}+1050w_{\text{HUC}}+2700w_{\text{CUC}}) \leq 0 \quad (3.14)$$

$$90.00w_{\text{Flex}} - (3w_{\text{NHEX}}+w_{\text{NHU}}+2w_{\text{NCU}}+1050w_{\text{HUC}}+2700w_{\text{CUC}}) \leq 0 \quad (3.15)$$

$$90.00w_{\text{Flex}} - (2w_{\text{NHEX}}+2w_{\text{NHU}}+2w_{\text{NCU}}+1050w_{\text{HUC}}+2700w_{\text{CUC}}) \leq 0 \quad (3.16)$$

$$91.51w_{\text{Flex}} - (3w_{\text{NHEX}}+w_{\text{NHU}}+2w_{\text{NCU}}+1300w_{\text{HUC}}+2950w_{\text{CUC}}) \leq 0 \quad (3.17)$$

$$120.0w_{\text{Flex}} - (2w_{\text{NHEX}}+2w_{\text{NHU}}+2w_{\text{NCU}}+1300w_{\text{HUC}}+2950w_{\text{CUC}}) \leq 0 \quad (3.18)$$

$$150.0w_{\text{Flex}} - (2w_{\text{NHEX}}+2w_{\text{NHFU}}+2w_{\text{NCU}}+3600w_{\text{HUC}}+5250w_{\text{CUC}}) \leq 0 \quad (3.19)$$

$$w_{\text{NHEX}}, w_{\text{NHFU}}, w_{\text{NCU}}, w_{\text{HUC}}, w_{\text{CUC}}, w_{\text{Flex}} \geq 0 \quad (3.20)$$

LP formulation for DMU C is;

$$\text{maximize } 74.24w_{\text{Flex}}$$

subject to:

$$3w_{\text{NHEX}}+w_{\text{NHFU}}+2w_{\text{NCU}}+1050w_{\text{HUC}}+2700w_{\text{CUC}} = 1 \quad (3.21)$$

$$36.95w_{\text{Flex}} - (3w_{\text{NHEX}}+w_{\text{NHFU}}+2w_{\text{NCU}}+450w_{\text{HUC}}+2100w_{\text{CUC}}) \leq 0 \quad (3.22)$$

$$70.63w_{\text{Flex}} - (3w_{\text{NHEX}}+w_{\text{NHFU}}+2w_{\text{NCU}}+1050w_{\text{HUC}}+2700w_{\text{CUC}}) \leq 0 \quad (3.23)$$

$$74.24w_{\text{Flex}} - (3w_{\text{NHEX}}+w_{\text{NHFU}}+2w_{\text{NCU}}+1050w_{\text{HUC}}+2700w_{\text{CUC}}) \leq 0 \quad (3.24)$$

$$90.00w_{\text{Flex}} - (3w_{\text{NHEX}}+w_{\text{NHFU}}+2w_{\text{NCU}}+1050w_{\text{HUC}}+2700w_{\text{CUC}}) \leq 0 \quad (3.25)$$

$$90.00w_{\text{Flex}} - (2w_{\text{NHEX}}+2w_{\text{NHFU}}+2w_{\text{NCU}}+1050w_{\text{HUC}}+2700w_{\text{CUC}}) \leq 0 \quad (3.26)$$

$$91.51w_{\text{Flex}} - (3w_{\text{NHEX}}+w_{\text{NHFU}}+2w_{\text{NCU}}+1300w_{\text{HUC}}+2950w_{\text{CUC}}) \leq 0 \quad (3.27)$$

$$120.0w_{\text{Flex}} - (2w_{\text{NHEX}}+2w_{\text{NHFU}}+2w_{\text{NCU}}+1300w_{\text{HUC}}+2950w_{\text{CUC}}) \leq 0 \quad (3.28)$$

$$150.0w_{\text{Flex}} - (2w_{\text{NHEX}}+2w_{\text{NHFU}}+2w_{\text{NCU}}+3600w_{\text{HUC}}+5250w_{\text{CUC}}) \leq 0 \quad (3.29)$$

$$w_{\text{NHEX}}, w_{\text{NHFU}}, w_{\text{NCU}}, w_{\text{HUC}}, w_{\text{CUC}}, w_{\text{Flex}} \geq 0 \quad (3.30)$$

LP formulation for DMU D is;

$$\text{maximize } 90.00w_{\text{Flex}}$$

subject to:

$$3w_{\text{NHEX}}+w_{\text{NHFU}}+2w_{\text{NCU}}+1050w_{\text{HUC}}+2700w_{\text{CUC}} = 1 \quad (3.31)$$

$$36.95w_{\text{Flex}} - (3w_{\text{NHEX}}+w_{\text{NHFU}}+2w_{\text{NCU}}+450w_{\text{HUC}}+2100w_{\text{CUC}}) \leq 0 \quad (3.32)$$

$$70.63w_{\text{Flex}} - (3w_{\text{NHEX}}+w_{\text{NHFU}}+2w_{\text{NCU}}+1050w_{\text{HUC}}+2700w_{\text{CUC}}) \leq 0 \quad (3.33)$$

$$74.24w_{\text{Flex}} - (3w_{\text{NHEX}}+w_{\text{NHFU}}+2w_{\text{NCU}}+1050w_{\text{HUC}}+2700w_{\text{CUC}}) \leq 0 \quad (3.34)$$

$$90.00w_{\text{Flex}} - (3w_{\text{NHEX}}+w_{\text{NHFU}}+2w_{\text{NCU}}+1050w_{\text{HUC}}+2700w_{\text{CUC}}) \leq 0 \quad (3.35)$$

$$90.00w_{\text{Flex}} - (2w_{\text{NHEX}}+2w_{\text{NHFU}}+2w_{\text{NCU}}+1050w_{\text{HUC}}+2700w_{\text{CUC}}) \leq 0 \quad (3.36)$$

$$91.51w_{\text{Flex}} - (3w_{\text{NHEX}}+w_{\text{NHFU}}+2w_{\text{NCU}}+1300w_{\text{HUC}}+2950w_{\text{CUC}}) \leq 0 \quad (3.37)$$

$$120.0w_{\text{Flex}} - (2w_{\text{NHEX}}+2w_{\text{NHFU}}+2w_{\text{NCU}}+1300w_{\text{HUC}}+2950w_{\text{CUC}}) \leq 0 \quad (3.38)$$

$$150.0w_{\text{Flex}} - (2w_{\text{NHEX}}+2w_{\text{NHFU}}+2w_{\text{NCU}}+3600w_{\text{HUC}}+5250w_{\text{CUC}}) \leq 0 \quad (3.39)$$

$$w_{\text{NHEX}}, w_{\text{NHFU}}, w_{\text{NCU}}, w_{\text{HUC}}, w_{\text{CUC}}, w_{\text{Flex}} \geq 0 \quad (3.40)$$

LP formulation for DMU E is;

$$\text{maximize } 90.00w_{\text{Flex}}$$

subject to:

$$2w_{\text{NHEX}}+2w_{\text{NHU}}+2w_{\text{NCU}}+1050w_{\text{HUC}}+2700w_{\text{CUC}} = 1 \quad (3.41)$$

$$36.95w_{\text{Flex}} - (3w_{\text{NHEX}}+w_{\text{NHU}}+2w_{\text{NCU}}+450w_{\text{HUC}}+2100w_{\text{CUC}}) \leq 0 \quad (3.42)$$

$$70.63w_{\text{Flex}} - (3w_{\text{NHEX}}+w_{\text{NHU}}+2w_{\text{NCU}}+1050w_{\text{HUC}}+2700w_{\text{CUC}}) \leq 0 \quad (3.43)$$

$$74.24w_{\text{Flex}} - (3w_{\text{NHEX}}+w_{\text{NHU}}+2w_{\text{NCU}}+1050w_{\text{HUC}}+2700w_{\text{CUC}}) \leq 0 \quad (3.44)$$

$$90.00w_{\text{Flex}} - (3w_{\text{NHEX}}+w_{\text{NHU}}+2w_{\text{NCU}}+1050w_{\text{HUC}}+2700w_{\text{CUC}}) \leq 0 \quad (3.45)$$

$$90.00w_{\text{Flex}} - (2w_{\text{NHEX}}+2w_{\text{NHU}}+2w_{\text{NCU}}+1050w_{\text{HUC}}+2700w_{\text{CUC}}) \leq 0 \quad (3.46)$$

$$91.51w_{\text{Flex}} - (3w_{\text{NHEX}}+w_{\text{NHU}}+2w_{\text{NCU}}+1300w_{\text{HUC}}+2950w_{\text{CUC}}) \leq 0 \quad (3.47)$$

$$120.0w_{\text{Flex}} - (2w_{\text{NHEX}}+2w_{\text{NHU}}+2w_{\text{NCU}}+1300w_{\text{HUC}}+2950w_{\text{CUC}}) \leq 0 \quad (3.48)$$

$$150.0w_{\text{Flex}} - (2w_{\text{NHEX}}+2w_{\text{NHU}}+2w_{\text{NCU}}+3600w_{\text{HUC}}+5250w_{\text{CUC}}) \leq 0 \quad (3.49)$$

$$w_{\text{NHEX}}, w_{\text{NHU}}, w_{\text{NCU}}, w_{\text{HUC}}, w_{\text{CUC}}, w_{\text{Flex}} \geq 0 \quad (3.50)$$

LP formulation for DMU F is;

$$\text{maximize } 91.51w_{\text{Flex}}$$

subject to:

$$3w_{\text{NHEX}}+w_{\text{NHU}}+2w_{\text{NCU}}+1300w_{\text{HUC}}+2950w_{\text{CUC}} = 1 \quad (3.51)$$

$$36.95w_{\text{Flex}} - (3w_{\text{NHEX}}+w_{\text{NHU}}+2w_{\text{NCU}}+450w_{\text{HUC}}+2100w_{\text{CUC}}) \leq 0 \quad (3.52)$$

$$70.63w_{\text{Flex}} - (3w_{\text{NHEX}}+w_{\text{NHU}}+2w_{\text{NCU}}+1050w_{\text{HUC}}+2700w_{\text{CUC}}) \leq 0 \quad (3.53)$$

$$74.24w_{\text{Flex}} - (3w_{\text{NHEX}}+w_{\text{NHU}}+2w_{\text{NCU}}+1050w_{\text{HUC}}+2700w_{\text{CUC}}) \leq 0 \quad (3.54)$$

$$90.00w_{\text{Flex}} - (3w_{\text{NHEX}}+w_{\text{NHU}}+2w_{\text{NCU}}+1050w_{\text{HUC}}+2700w_{\text{CUC}}) \leq 0 \quad (3.55)$$

$$90.00w_{\text{Flex}} - (2w_{\text{NHEX}}+2w_{\text{NHU}}+2w_{\text{NCU}}+1050w_{\text{HUC}}+2700w_{\text{CUC}}) \leq 0 \quad (3.56)$$

$$91.51w_{\text{Flex}} - (3w_{\text{NHEX}}+w_{\text{NHU}}+2w_{\text{NCU}}+1300w_{\text{HUC}}+2950w_{\text{CUC}}) \leq 0 \quad (3.57)$$

$$120.0w_{\text{Flex}} - (2w_{\text{NHEX}}+2w_{\text{NHU}}+2w_{\text{NCU}}+1300w_{\text{HUC}}+2950w_{\text{CUC}}) \leq 0 \quad (3.58)$$

$$150.0w_{\text{Flex}} - (2w_{\text{NHEX}}+2w_{\text{NHU}}+2w_{\text{NCU}}+3600w_{\text{HUC}}+5250w_{\text{CUC}}) \leq 0 \quad (3.59)$$

$$w_{\text{NHEX}}, w_{\text{NHU}}, w_{\text{NCU}}, w_{\text{HUC}}, w_{\text{CUC}}, w_{\text{Flex}} \geq 0 \quad (3.60)$$

LP formulation for DMU G is;

maximize $120.0w_{Flex}$

subject to:

$$2w_{NHEX}+2w_{NHU}+2w_{NCU}+1300w_{HUC}+2950w_{CUC} = 1 \quad (3.61)$$

$$36.95w_{Flex} - (3w_{NHEX}+w_{NHU}+2w_{NCU}+450w_{HUC}+2100w_{CUC}) \leq 0 \quad (3.62)$$

$$70.63w_{Flex} - (3w_{NHEX}+w_{NHU}+2w_{NCU}+1050w_{HUC}+2700w_{CUC}) \leq 0 \quad (3.63)$$

$$74.24w_{Flex} - (3w_{NHEX}+w_{NHU}+2w_{NCU}+1050w_{HUC}+2700w_{CUC}) \leq 0 \quad (3.64)$$

$$90.00w_{Flex} - (3w_{NHEX}+w_{NHU}+2w_{NCU}+1050w_{HUC}+2700w_{CUC}) \leq 0 \quad (3.65)$$

$$90.00w_{Flex} - (2w_{NHEX}+2w_{NHU}+2w_{NCU}+1050w_{HUC}+2700w_{CUC}) \leq 0 \quad (3.66)$$

$$91.51w_{Flex} - (3w_{NHEX}+w_{NHU}+2w_{NCU}+1300w_{HUC}+2950w_{CUC}) \leq 0 \quad (3.67)$$

$$120.0w_{Flex} - (2w_{NHEX}+2w_{NHU}+2w_{NCU}+1300w_{HUC}+2950w_{CUC}) \leq 0 \quad (3.68)$$

$$150.0w_{Flex} - (2w_{NHEX}+2w_{NHU}+2w_{NCU}+3600w_{HUC}+5250w_{CUC}) \leq 0 \quad (3.69)$$

$$w_{NHEX}, w_{NHU}, w_{NCU}, w_{HUC}, w_{CUC}, w_{Flex} \geq 0 \quad (3.70)$$

LP formulation for DMU H is;

maximize $150.0w_{Flex}$

subject to:

$$2w_{NHEX}+2w_{NHU}+2w_{NCU}+3600w_{HUC}+5250w_{CUC} = 1 \quad (3.71)$$

$$36.95w_{Flex} - (3w_{NHEX}+w_{NHU}+2w_{NCU}+450w_{HUC}+2100w_{CUC}) \leq 0 \quad (3.72)$$

$$70.63w_{Flex} - (3w_{NHEX}+w_{NHU}+2w_{NCU}+1050w_{HUC}+2700w_{CUC}) \leq 0 \quad (3.73)$$

$$74.24w_{Flex} - (3w_{NHEX}+w_{NHU}+2w_{NCU}+1050w_{HUC}+2700w_{CUC}) \leq 0 \quad (3.74)$$

$$90.00w_{Flex} - (3w_{NHEX}+w_{NHU}+2w_{NCU}+1050w_{HUC}+2700w_{CUC}) \leq 0 \quad (3.75)$$

$$90.00w_{Flex} - (2w_{NHEX}+2w_{NHU}+2w_{NCU}+1050w_{HUC}+2700w_{CUC}) \leq 0 \quad (3.76)$$

$$91.51w_{Flex} - (3w_{NHEX}+w_{NHU}+2w_{NCU}+1300w_{HUC}+2950w_{CUC}) \leq 0 \quad (3.77)$$

$$120.0w_{Flex} - (2w_{NHEX}+2w_{NHU}+2w_{NCU}+1300w_{HUC}+2950w_{CUC}) \leq 0 \quad (3.78)$$

$$150.0w_{Flex} - (2w_{NHEX}+2w_{NHU}+2w_{NCU}+3600w_{HUC}+5250w_{CUC}) \leq 0 \quad (3.79)$$

$$w_{NHEX}, w_{NHU}, w_{NCU}, w_{HUC}, w_{CUC}, w_{Flex} \geq 0 \quad (3.80)$$

Using Excel Solver with ‘Assume Non-Negative’ and ‘Assume Linear Model’ choices selected, and with the “Precision” parameter of 10^{-6} , the corresponding relative efficiencies for all DMUs and weights of the inputs and output are found by solving the

LPs for all the DMUs individually on different Excel worksheets. There is not any value-judgment constraint. These calculated optimal relative efficiencies and the optimal weights are listed in Table 3.3.

Table 3.3. Relative efficiencies and optimal weights of the HENs

DMU	Relative Efficiency	w_{NHEX}	w_{NHU}	w_{NCU}	w_{HUC}	w_{CUC}	w_{Flex}
A	0.89	0	0	0	0.002222	0	0.024074
B	0.78	0	0.125000	0	0.000833	0	0.011111
C	0.82	0	0.125000	0	0.000833	0	0.011111
D	1.00	0	0.125000	0	0.000833	0	0.011111
E	0.93	0	0	0	0.000952	0	0.010317
F	1.00	0.063586	0.614530	0	0	0.000066	0.010928
G	1.00	0.206954	0	0	0	0.000199	0.008333
H	1.00	0.076000	0.246000	0	0.000120	0	0.006667

HEN structures D, F, G and H are equally efficient, B is the least efficient. Hence, D, F, G and H together form the efficient frontier (they are on the efficient frontier), while the others are inside (below) of that frontier.

However, if one examines the optimal weights given in Table 3.3., it is seen that some of them, particularly those associated with inputs (w_{NHEX} through w_{CUC}), are zero. On the other hand, all values of the weights of CU (w_{NCU}) are zero. If one examines the alternative HEN structures in Fig. 3.1, it is seen that all eight structures have identical number of (two) coolers. Therefore, the number of cooler has the same effect (or, no distinguishing effect) on the efficiency calculations. Thus, zero values of w_{CU} for all DMUs are not surprising. Since there is only one output, its weight does not get zero value during optimization. This means that no weight (significance) is given to these inputs with zero weights in determining the relative efficiencies. This may not always be plausible for an engineer. For example zero weight of HUC disregards steam consumption on the HEN structure and this may not be acceptable for an engineer. Therefore one should use what is

called the “value-judgment constraints” in the DEA literature. These constraints allow making the DEA model more representative of the underlying situation being modeled.

3.1.2. DEA of the HEN Structures with Value-Judgment Constraints

In cases where zero weights appear in the solution, which eliminates the effect of the corresponding inputs on efficiency determination, one may impose some constraints in order to find the relative efficiencies without zero values of the weights.

For instance, to avoid zero weights in the solution, some constraint(s) may be added to the formulation for each DMU. To see the effects of different kinds of constraints, some examples are worked out as follows.

3.1.2.1. Value Judgment with Bound Constraints on Weights: In this section the effect of lower-bound constraints on the input-output weights are studied. The aim is to completely avoid the possibility of getting zero optimal values for the weights. For this purpose the following lower bound constraints are examined; $w \geq 0.00001$, $w \geq 0.00010$, $w \geq 0.00100$, and $w \geq 0.000112$.

For the last one, the right-hand-side value of 0.000112 was found by trial and error as being the limit beyond which the HEN structures begin to show infeasibility, starting from the structure H. These side constraints are applied to all DMUs (HEN structures). Using Excel Solver with ‘Assume Non-Negative’ and ‘Assume Linear Model’ choices selected, and with the “Precision” parameter of 10^{-6} , the corresponding relative efficiencies for all DMUs and weights of the input and outputs are found by solving the LPs for all the DMUs individually on different Excel worksheets. With the $w \geq 0.00100$ constraint there is no feasible solution for any of the DMUs using Excel Solver. These calculated optimal relative efficiencies and the optimal weights are listed in Table 3.4 through Table 3.6.

Table 3.4. Relative efficiencies and optimal weights with the constraint $w \geq 0.00001$ for the HEN structures

DMU	Relative Efficiency	W_{NHEX}	W_{NHU}	W_{NCU}	W_{HUC}	W_{CUC}	W_{Flex}
A	0.88	0.000010	0.000010	0.000010	0.002175	0.000010	0.023813
B	0.78	0.000010	0.130185	0.000010	0.000803	0.000010	0.011111
C	0.82	0.000010	0.130185	0.000010	0.000803	0.000010	0.011111
D	1.00	0.000010	0.130185	0.000010	0.000803	0.000010	0.011111
E	0.93	0.000010	0.000010	0.000010	0.000927	0.000010	0.010285
F	1.00	0.066882	0.621122	0.000010	0.000010	0.000056	0.010928
G	1.00	0.000010	0.000010	0.000010	0.000010	0.000335	0.008333
H	1.00	0.170577	0.000010	0.000010	0.000010	0.000151	0.006667

Table 3.5. Relative efficiencies and optimal weights with the constraint $w \geq 0.00010$ for the HEN structures

DMU	Relative Efficiency	W_{NHEX}	W_{NHU}	W_{NCU}	W_{HUC}	W_{CUC}	W_{Flex}
A	0.79	0.000100	0.000100	0.000100	0.001754	0.000100	0.021467
B	0.78	0.000100	0.176850	0.000100	0.000526	0.000100	0.011111
C	0.82	0.000100	0.176850	0.000100	0.000526	0.000100	0.011111
D	1.00	0.000100	0.176850	0.000100	0.000526	0.000100	0.011111
E	0.90	0.000100	0.000100	0.000100	0.000695	0.000100	0.009989
F	0.97	0.077033	0.343700	0.000100	0.000100	0.000100	0.010556
G	1.00	0.000100	0.000100	0.000100	0.000100	0.000295	0.008333
H	0.82	0.114600	0.000100	0.000100	0.000100	0.000100	0.005455

Table 3.6. Relative efficiencies and optimal weights with the constraint $w \geq 0.000112$ for the HEN structures

DMU	Relative Efficiency	w_{NHEX}	w_{NHU}	w_{NCU}	w_{HUC}	w_{CUC}	w_{Flex}
A	0.78	0.000112	0.000112	0.000112	0.001698	0.000112	0.021155
B	0.78	0.000112	0.183072	0.000112	0.000489	0.000112	0.011111
C	0.82	0.000112	0.183072	0.000112	0.000489	0.000112	0.011111
D	1.00	0.000112	0.183072	0.000112	0.000489	0.000112	0.011111
E	0.90	0.000112	0.000112	0.000112	0.000664	0.000112	0.009949
F	0.96	0.066277	0.324944	0.000112	0.000112	0.000112	0.010489
G	1.00	0.000112	0.000112	0.000112	0.000112	0.000289	0.008333
H	0.61	0.008352	0.000112	0.000112	0.000112	0.000112	0.004110

The effects of the absence and presence of the value judgment constraints as lower bounds on the weights, and the effects of the right-hand-side values on the relative efficiency ranking of the HEN structures are summarized in Table 3.7.

Table 3.7. Effects of the value judgment constraints as lower bounds

Relative Efficiency Ranking of DMUs			
$w \geq 0$	$w \geq 0.00001$	$w \geq 0.00010$	$w \geq 0.000112$
D 1.00	D 1.00	D 1.00	D 1.00
F 1.00	F 1.00	G 1.00	G 1.00
G 1.00	G 1.00	F 0.97	F 0.96
H 1.00	H 1.00	E 0.90	E 0.90
E 0.93	E 0.93	C 0.82	C 0.82
A 0.89	A 0.88	H 0.82	A 0.78
C 0.82	C 0.82	A 0.79	B 0.78
B 0.78	B 0.78	B 0.78	H 0.61

As can be seen from Table 3.7, some HEN structures (D, F, G, and E) are not very sensitive to the value-judgment constraints introduced on the input-output weights as lower

bounds; they remain at the top rows of the efficiency-ranking table. Similarly HEN structures A, B, and C are not very sensitive as well; they remain at the bottom rows of the efficiency-ranking table. On the other hand, HEN structure H is quite sensitive; it loses its rank as the right-hand-side of the side constraint increases (its relative efficiency decreases from 1.00 to 0.82 and then to 0.62). If Tables 3.4 through 3.6 are examined for the optimal weights w_{NHEX} of the structure H, it is seen that w_{NHEX} values decrease as the right-hand-side of the side constraint increases. Thus, the structure H loses its rank since its efficiency in providing high flexibility (output) with less number of process heat exchangers (input) decreases relative to other HEN structures.

3.1.2.2. Value-Judgment with Inequality Constraints on Input Weights: In this section the effect of inequality constraints between various input weights are studied. For this purpose the following inequalities are examined:

$$\text{i) } w_{\text{HUC}} \geq w_{\text{CUC}}$$

This value judgment constraint signifies that steam cost may be judged to be more important than cooling water cost for all HEN structures.

$$\text{ii) } w_{\text{NHEX}} \geq w_{\text{NHU}}$$

This value judgment constraint signifies that presence (number) of process stream heat exchanger may be judged to be more important than the number of external heaters for all HEN structures.

$$\begin{aligned} \text{iii) } w_{\text{HUC}} &\geq w_{\text{CUC}} \\ w_{\text{NHU}} &\geq w_{\text{NCU}} \\ w_{\text{NHEX}} &\geq w_{\text{NCU}} \\ w_{\text{NHEX}} &\geq w_{\text{NHU}} \end{aligned}$$

These value judgment constraints signify that steam cost may be judged to be more important than cooling water cost; amount of steam used in the heaters may be judged to be more important than cooling water used in the coolers; presence of process stream heat exchanger may be judged to be more important than the number of external heaters and

coolers; and presence (number) of process stream heat exchanger may be judged to be more important than the number of external heaters for all HEN structures, respectively.

Using Excel Solver with ‘Assume Non-Negative’ and ‘Assume Linear Model’ choices signed, and with the “Precision” parameter of 10^{-6} , the corresponding relative efficiencies for all DMUs and weights of the inputs and output are found by solving the LPs for all the DMUs individually on different Excel worksheets. These calculated optimal relative efficiencies and the optimal weights are listed in Table 3.8 through Table 3.10.

Table 3.8. Relative efficiencies and optimal weights with the constraint $w_{HUC} \geq w_{CUC}$

DMU	Relative Efficiency	w_{NHEX}	w_{NHU}	w_{NCU}	w_{HUC}	w_{CUC}	w_{Flex}
A	0.89	0	0	0	0.002222	0	0.024074
B	0.78	0	0.125000	0	0.000833	0	0.011111
C	0.82	0	0.125000	0	0.000833	0	0.011111
D	1.00	0	0.125000	0	0.000833	0	0.011111
E	0.93	0	0	0	0.000952	0	0.010317
F	1.00	0.074477	0.636311	0	0.000033	0.000033	0.010928
G	1.00	0.334746	0	0	0.000254	0	0.008333
H	1.00	0.210409	0	0	0.000089	0.000089	0.006667

Table 3.9. Relative efficiencies and optimal weights with the constraint $w_{NHEX} \geq w_{NHU}$

DMU	Relative Efficiency	w_{NHEX}	w_{NHU}	w_{NCU}	w_{HUC}	w_{CUC}	w_{Flex}
A	0.89	0	0	0	0.002222	0	0.024074
B	0.73	0	0	0	0.000952	0	0.010317
C	0.77	0	0	0	0.000952	0	0.010317
D	0.93	0	0	0	0.000952	0	0.010317
E	0.93	0	0	0	0.000952	0	0.010317
F	0.76	0	0	0	0	0.000339	0.008333
G	1.00	0.188095	0.188095	0	0.000190	0	0.008333
H	1.00	0.165563	0	0	0	0.000159	0.006667

Table 3.10. Relative efficiencies and optimal weights with the constraints $w_{HUC} \geq w_{CUC}$,

$w_{NHU} \geq w_{NCU}$, $w_{NHEX} \geq w_{NCU}$, and $w_{NHEX} \geq w_{NHU}$

DMU	Relative Efficiency	w_{NHEX}	w_{NHU}	w_{NCU}	w_{HUC}	w_{CUC}	w_{Flex}
A	0.89	0	0	0	0.002222	0	0.024074
B	0.73	0	0	0	0.000952	0	0.010317
C	0.77	0	0	0	0.000952	0	0.010317
D	0.93	0	0	0	0.000952	0	0.010317
E	0.93	0	0	0	0.000952	0	0.010317
F	0.76	0.111068	0.111068	0.111068	0.000078	0.000078	0.008333
G	1.00	0	0	0	0.000769	0	0.008333
H	1.00	0.104636	0.104636	0.104636	0.000132	0	0.006667

The effects of the absence and presence of the value judgment constraints as inequalities of the input weights on the relative efficiency ranking of the HEN structures are summarized in Table 3.11.

Table 3.11. Effects of the value judgment inequality constraints

Relative Efficiency Ranking of DMUs				
No value judgment	$w_{HUC} \geq w_{CUC}$	$w_{NHEX} \geq w_{NHU}$	$w_{HUC} \geq w_{CUC}, w_{NHU} \geq w_{NCU}$ $w_{NHEX} \geq w_{NCU}, w_{NHEX} \geq w_{NHU}$	
D 1.00	D 1.00	G 1.00	G 1.00	
F 1.00	F 1.00	H 1.00	H 1.00	
G 1.00	G 1.00	D 0.93	D 0.93	
H 1.00	H 1.00	E 0.93	E 0.93	
E 0.93	E 0.93	A 0.89	A 0.89	
A 0.89	A 0.89	C 0.77	C 0.77	
C 0.82	C 0.82	F 0.76	F 0.76	
B 0.78	B 0.78	B 0.73	B 0.73	

As can be seen from Table 3.11, some HEN structures (A, E, G, H and E) are totally insensitive to the value-judgment inequalities introduced on the input weights; their relative efficiency values do not change. HEN structures B, C, and D are only moderately sensitive to the value-judgment inequalities introduced on the input weights. On the other hand, HEN structure F is quite sensitive; it loses its rank with the introduction of $w_{NHEX} \geq w_{NHU}$ constraint (its relative efficiency decreases from 1.00 to 0.76). If Table 3.3 and Tables 3.8 through 3.10 are examined for the optimal weights, it is seen that w_{NHU} values are the ones most affected by the introduction of $w_{NHEX} \geq w_{NHU}$ constraint.

3.1.2.3 Value-Judgment with Inequality Constraints on Input Weights with Multipliers: In this section the effects of the integer multipliers in inequality constraints between various input weights are studied. For this purpose the following inequalities are examined individually: $w_{NHEX} \geq 2 \times w_{NHU}$, $w_{NHEX} \geq 3 \times w_{NHU}$, and $w_{NHEX} \geq 30 \times w_{NHU}$. These constraints signify that, for example, the presence (number) of process stream heat exchanger may be judged to be two times more important than the number of external heaters, etc. The effects of integer multipliers are studied for the inequality between w_{NHEX} and w_{NHU} since the results of the previous section (Table 3.11) show that $w_{NHEX} \geq w_{NHU}$ constraint is the most effective one.

Using Excel Solver with ‘Assume Non-Negative’ and ‘Assume Linear Model’ choices selected, and with the “Precision” parameter of 10^{-6} , the corresponding relative efficiencies for all DMUs and weights of the inputs and the output are found by solving the LPs for all the DMUs individually on different Excel worksheets. These calculated optimal relative efficiencies and the optimal weights are listed in Table 3.12 through Table 3.14.

Table 3.12. Relative efficiencies and optimal weights with constraint $w_{\text{NHEX}} \geq 2 \times w_{\text{NHU}}$

DMU	Relative Efficiency	w_{NHEX}	w_{NHU}	w_{NCU}	w_{HUC}	w_{CUC}	w_{Flex}
A	0.89	0	0	0	0.002222	0	0.024074
B	0.73	0	0	0	0.000952	0	0.010317
C	0.77	0	0	0	0.000952	0	0.010317
D	0.93	0	0	0	0.000952	0	0.010317
E	0.93	0	0	0	0.000952	0	0.010317
F	0.76	0	0	0.339674	0	0.000109	0.008333
G	1.00	0.158629	0.079315	0	0	0.000178	0.008333
H	1.00	0.192683	0.096341	0	0.000171	0	0.006667

Table 3.13. Relative efficiencies and optimal weights with constraint $w_{\text{NHEX}} \geq 3 \times w_{\text{NHU}}$

DMU	Relative Efficiency	w_{NHEX}	w_{NHU}	w_{NCU}	w_{HUC}	w_{CUC}	w_{Flex}
A	0.89	0	0	0	0.002222	0	0.024074
B	0.73	0	0	0	0.000952	0	0.010317
C	0.77	0	0	0	0.000952	0	0.010317
D	0.93	0	0	0	0.000952	0	0.010317
E	0.93	0	0	0	0.000952	0	0.010317
F	0.76	0	0	0	0.000769	0	0.008333
G	1.00	0	0	0	0.000769	0	0.008333
H	1.00	0.137615	0.045872	0	0	0.000147	0.006667

Table 3.14. Relative efficiencies and optimal weights with constraint $w_{NHEX} \geq 30 \times w_{NHU}$

DMU	Relative Efficiency	w_{NHEX}	w_{NHU}	w_{NCU}	w_{HUC}	w_{CUC}	w_{Flex}
A	0.89	0	0	0	0.002222	0	0.024074
B	0.73	0	0	0	0.000952	0	0.010317
C	0.77	0	0	0	0.000952	0	0.010317
D	0.93	0	0	0	0.000952	0	0.010317
E	0.93	0	0	0	0.000952	0	0.010317
F	0.76	0	0	0.339674	0	0.000109	0.008333
G	1.00	0.326267	0.010876	0	0.000251	0	0.008333
H	1.00	0.162267	0.005409	0	0	0.000158	0.006667

The effects of the integer multipliers in value judgment inequality constraints of the input weights on the relative efficiency ranking of the HEN structures are summarized in Table 3.15.

Table 3.15. Effects of the value judgment inequality constraint multipliers

Relative Efficiency Ranking of DMUs									
No value judgment		$w_{NHEX} \geq w_{NHU}$		$w_{NHEX} \geq 2w_{NHU}$		$w_{NHEX} \geq 3w_{NHU}$		$w_{NHEX} \geq 30w_{NHU}$	
D	1.00	G	1.00	G	1.00	G	1.00	G	1.00
F	1.00	H	1.00	H	1.00	H	1.00	H	1.00
G	1.00	D	0.93	D	0.93	D	0.93	D	0.93
H	1.00	E	0.93	E	0.93	E	0.93	E	0.93
E	0.93	A	0.89	A	0.89	A	0.89	A	0.89
A	0.89	C	0.77	C	0.77	C	0.77	C	0.77
C	0.82	F	0.76	F	0.76	F	0.76	F	0.76
B	0.78	B	0.73	B	0.73	B	0.73	B	0.73

As it can be seen from Table 3.15, all HEN structures are totally insensitive to the value of the integer multiplier in value-judgment inequalities introduced on the input

weights; their relative efficiency values do not change. Compared to nominal case (no value judgment) the presence of the inequality $w_{\text{NHEX}} \geq n \times w_{\text{NHU}}$ is effective but the value of the multiplier n is not important.

As the results of the additions of the value-judgment constraints as well as the side constraints on the weights show, the DEA may be quite subjective. There are almost infinitely many more possibilities for the value-judgment constraints. As demonstrated here, the addition of value-judgment constraints may or may not have significant effect on the final result, i.e., the relative efficiency ranking of the DMUs. This may be seen as the weakness of DEA. However, this flexibility of imposing value judgments may also be considered as the strength of the DEA. The chemical process design is considered to have an art part, which is subjective, as well a science part. The art part of the design is what makes it “state-of-the-art”. Similarly, the DEA with value judgment may also be considered as the “state-of-the-art”; the science part coming from the LP formulation and the art part due to value-judgment constraints.

Anyway, the DEA enables the determination of the efficiency of the HEN structure(s) under multi input conditions. Without the DEA, it is hard or impossible to rank efficiencies by just looking at the individual input-output relationships for each HEN structure one by one, as illustrated via Fig. 3.3 through Fig. 3.8.

3.2. Alternative Flowsheets for the Hydrodealkylation of Toluene (HDA) Process

The second chemical engineering application of DEA deals with the hydrodealkylation of toluene process (HDA). The data for the example are taken from a textbook (Douglas, 1988).

The reactions for the HDA process are as follows;

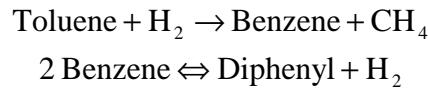

The HDA process produces Benzene as the product from toluene and hydrogen feeds. This process has been used in many journal articles dealing with the process-systems-engineering research topics. In this thesis, the HDA process is used for the first time as an application example for the DEA. Douglas (1988) presents a base-case flowsheet and 5 alternative flowsheets for the HDA process. The alternative flowsheets are derived from this base-case process by taking some decisions on the process and flowsheet to reduce the costs of the production. Some of the examples of these decisions can be given as “purification of the hydrogen feed stream”, “recycling of diphenyl”, “purification of the gas-recycle stream”, and “energy integration” to reduce the heating and cooling costs.

The flowsheets taken from the textbook are as follows:

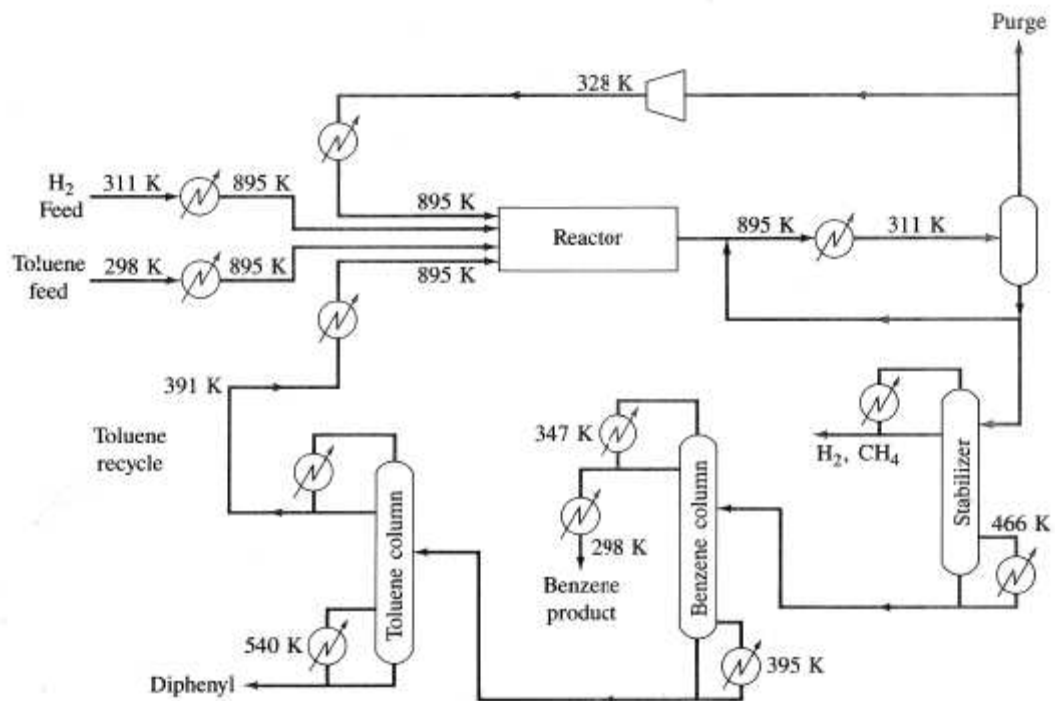

Figure 3.9. Flowsheet of the base-case HDA process (Douglas, 1988)

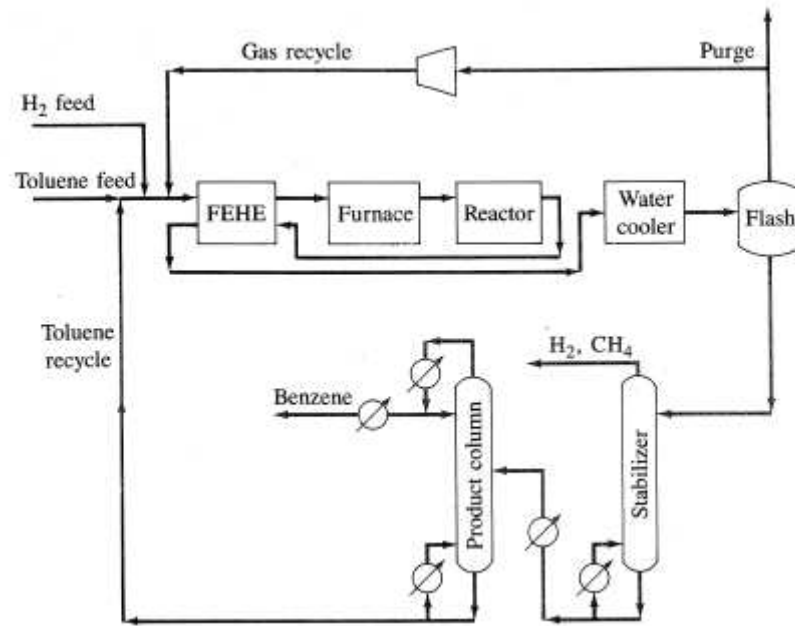

Figure 3.10. Flowsheet alternative 1 for the HDA process (Douglas, 1988)

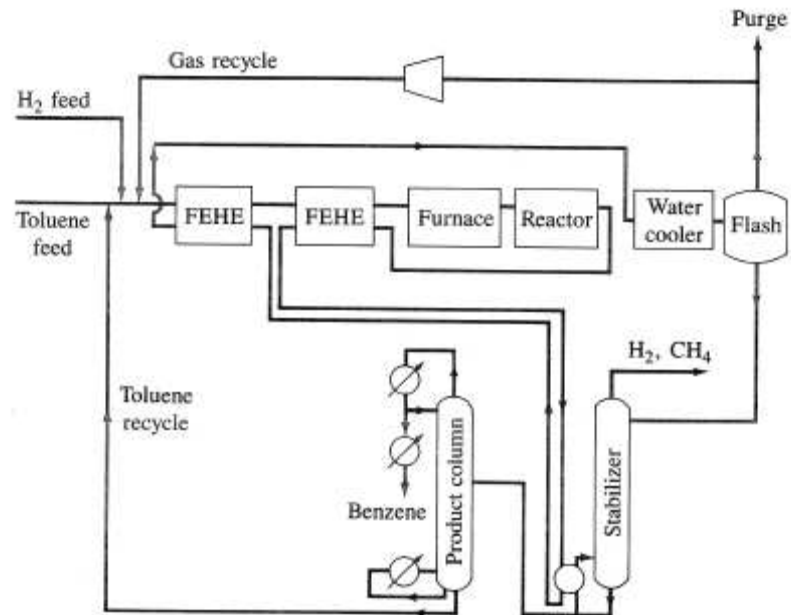

Figure 3.11. Flowsheet alternative 2 for the HDA process (Douglas, 1988)

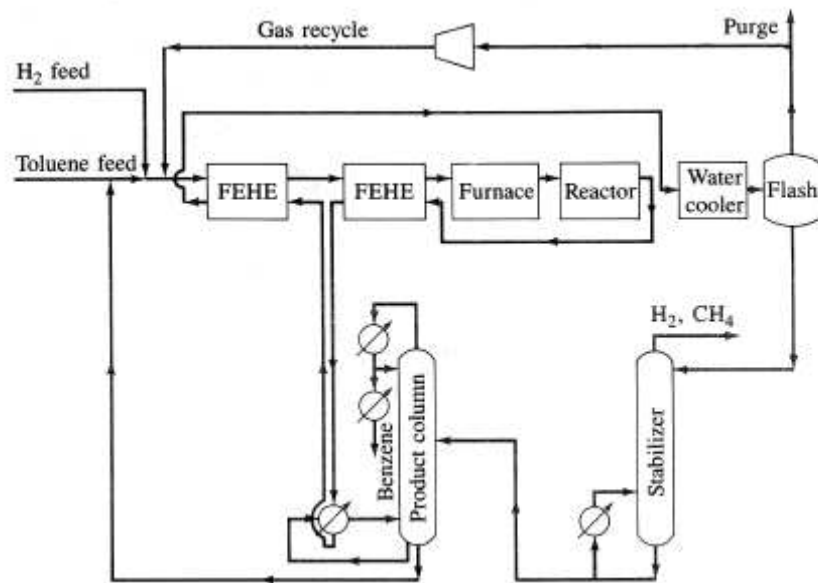

Figure 3.12. Flowsheet alternative 3 for the HDA process (Douglas, 1988)

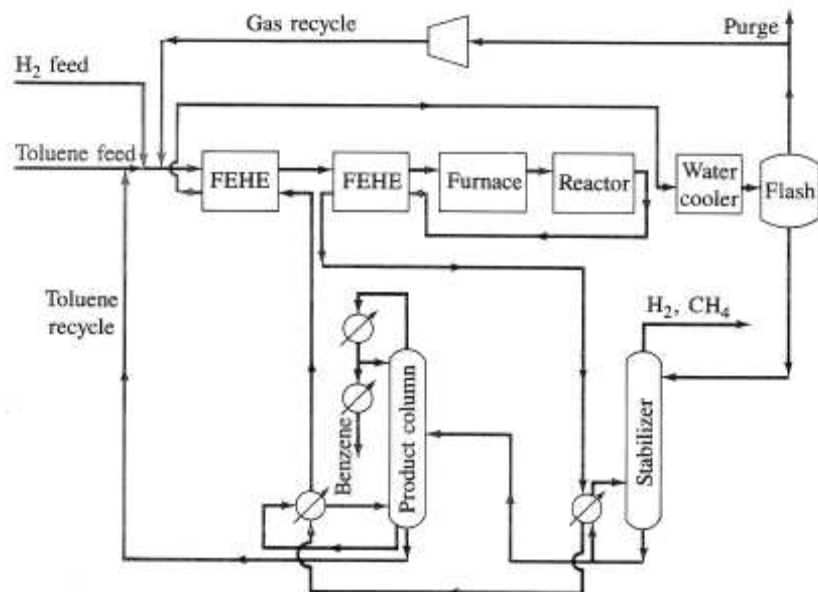

Figure 3.13. Flowsheet alternative 4 for the HDA process (Douglas, 1988)

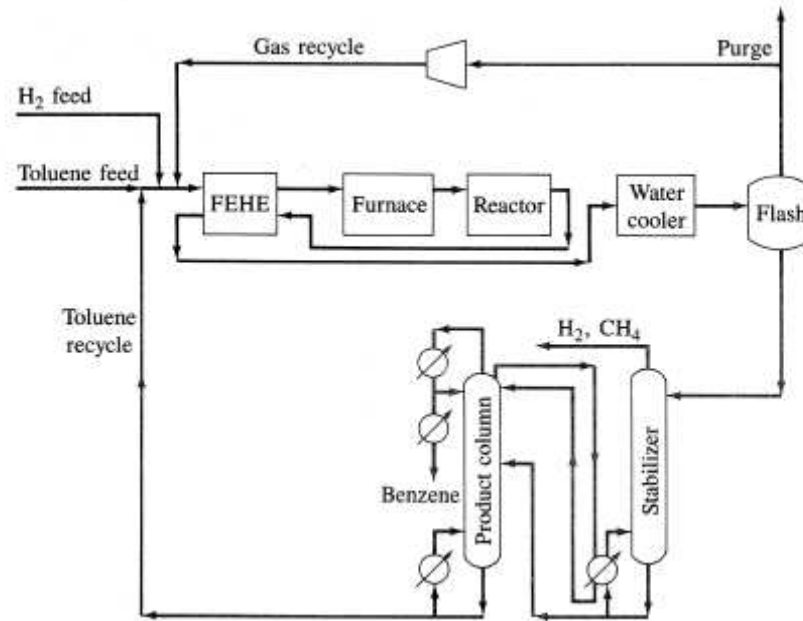

Figure 3.14. Flowsheet alternative 5 for the HDA process (Douglas, 1988)

Douglas (1988) performs the mass and energy balance calculations for the base-case and all alternative HDA flowsheets, and presents the results together with their economic analyses. The original table presented by Douglas (1988) is given as Table 3.6.

Table 3.16. Properties of the HDA flowsheet alternatives (Douglas, 1988)

	Base case	Alternative				
		1	2	3	4	5
TAC (\$10 ⁶ /yr)	5.19	3.83	3.71	3.60	3.57	4.09
Annualized capital cost (\$10 ⁶ /yr)	1.09	1.30	1.26	1.26	1.27	1.50
Annualized operating cost (\$10 ⁶ /yr)	4.10	2.53	2.44	2.35	2.30	2.59
Conversion (%)	75.0	97.3	97.0	97.6	97.7	98.2
H ₂ composition in gas recycle (%)	53.0	29.4	29.7	29.3	29.3	29.2
FEHE energy recovery (%), cold stream basis	85.4	94.2	93.4	89.9	85.6	90.6
ΔT_{min} (K)	10	36	32	10	9	12
Number of units	7	7	8	8	8	7
Stabilizer column						
Fractional loss of benzene (%)	0.5	0.2	0.2	0.2	0.2	0.4
Product column						
Fractional recovery (%)	99.0	99.0	97.8	99.1	99.1	99.1
Reflux ratio	1.2	1.2	1.3	1.4	1.3	1.1
Pressure (kPa)	101	101	101	101	101	586

For the DEA, the base-case and five alternative flowsheets are considered as DMUs; thus the total number of DMUs is six. The outputs and inputs are selected as;

Outputs: Loss of Benzene in stabilizer (LBS) (%)
 Conversion (CONV) (%)
 Energy recovery (ER) (%)
 Recovery of Benzene in product column (RB) (%)

Inputs: Total annual cost (TAC) (\$M/yr)
 Number of units (NU)

The input/output data for the six DMUs are tabulated below.

Table 3.17. The input/output data for the HDA process alternatives

DMU	Inputs		Outputs			
	TAC (\$M/yr)	NU	LBS (%)	CONV (%)	ER (%)	RB (%)
Base	5.19	7	0.5	75.0	85.4	99.0
Alt. 1	3.83	7	0.2	97.3	94.2	99.0
Alt. 2	3.71	8	0.2	97.0	93.4	97.8
Alt. 3	3.60	8	0.2	97.6	89.9	99.1
Alt. 4	3.57	8	0.2	97.7	85.6	99.1
Alt. 5	4.09	7	0.4	98.2	90.6	99.1

The aim of the DEA is to select the most efficient flowsheet and to rank the alternatives with respect to relative efficiencies as computed by the DEA. The DEA will show which alternative flowsheet yields less LBS and more CONV, ER, RB (outputs) per given TAC and NU (inputs).

3.2.1. Basic DEA of the HDA Process

Firstly, the LP formulations of each DMU should be made. For this purpose, weights are assigned for each input and output such as w_{TAC} , w_{NU} , ..., w_{RB} in the sequence given in Table 3.15 above. Since the aim is to maximize the outputs, one minus the fractional loss in stabilizer (1.0–LBS) is used as a factor throughout the calculations. In this way, when the term weighted with (1.0–LBS) is maximized, LBS is automatically minimized.

The LP formulation for the Base-case becomes;

$$\text{maximize} \quad (1-0.5)w_{LBS}+75w_{CONV}+85.4w_{ER}+99w_{RB}$$

subject to:

$$5.19w_{TAC}+7w_{NU}=1 \quad (3.81)$$

$$(1-0.5)w_{LBS}+75.0w_{CONV}+85.4w_{ER}+99.0w_{RB} - (5.19w_{TAC}+7w_{NU}) \leq 0 \quad (3.82)$$

$$(1-0.2)w_{LBS}+97.3w_{CONV}+94.2w_{ER}+99.0w_{RB} - (3.83w_{TAC}+7w_{NU}) \leq 0 \quad (3.83)$$

$$(1-0.2)w_{LBS}+97.0w_{CONV}+93.4w_{ER}+97.8w_{RB} - (3.71w_{TAC}+8w_{NU}) \leq 0 \quad (3.84)$$

$$(1-0.2)w_{LBS}+97.6w_{CONV}+89.9w_{ER}+99.1w_{RB} - (3.60w_{TAC}+8w_{NU}) \leq 0 \quad (3.85)$$

$$(1-0.2)w_{LBS}+97.7w_{CONV}+85.6w_{ER}+99.1w_{RB} - (3.57w_{TAC}+8w_{NU}) \leq 0 \quad (3.86)$$

$$(1-0.4)w_{LBS}+98.2w_{CONV}+90.6w_{ER}+99.1w_{RB} - (4.09w_{TAC}+7w_{NU}) \leq 0 \quad (3.87)$$

$$w_{TAC}, w_{NU}, w_{LBS}, w_{CONV}, w_{ER}, w_{RB} \geq 0 \quad (3.88)$$

The LP formulation for the Alternative 1 becomes;

$$\text{maximize} \quad (1-0.2)w_{LBS}+97.3w_{CONV}+94.2w_{ER}+99.0w_{RB}$$

subject to:

$$3.83w_{TAC}+7w_{NU}=1 \quad (3.89)$$

$$(1-0.5)w_{LBS}+75.0w_{CONV}+85.4w_{ER}+99.0w_{RB} - (5.19w_{TAC}+7w_{NU}) \leq 0 \quad (3.90)$$

$$(1-0.2)w_{LBS}+97.3w_{CONV}+94.2w_{ER}+99.0w_{RB} - (3.83w_{TAC}+7w_{NU}) \leq 0 \quad (3.91)$$

$$(1-0.2)w_{LBS}+97.0w_{CONV}+93.4w_{ER}+97.8w_{RB} - (3.71w_{TAC}+8w_{NU}) \leq 0 \quad (3.92)$$

$$(1-0.2)w_{LBS}+97.6w_{CONV}+89.9w_{ER}+99.1w_{RB} - (3.60w_{TAC}+8w_{NU}) \leq 0 \quad (3.93)$$

$$(1-0.2)w_{LBS}+97.7w_{CONV}+85.6w_{ER}+99.1w_{RB} - (3.57w_{TAC}+8w_{NU}) \leq 0 \quad (3.94)$$

$$(1-0.4)w_{LBS}+98.2w_{CONV}+90.6w_{ER}+99.1w_{RB} - (4.09w_{TAC}+7w_{NU}) \leq 0 \quad (3.95)$$

$$w_{TAC}, w_{NU}, w_{LBS}, w_{CONV}, w_{ER}, w_{RB} \geq 0 \quad (3.96)$$

The LP formulation for the Alternative 2 becomes;

$$\text{maximize } (1-0.2)w_{LBS}+97.0w_{CONV}+93.4w_{ER}+97.8w_{RB}$$

subject to:

$$3.71w_{TAC}+8w_{NU} = 1 \quad (3.97)$$

$$(1-0.5)w_{LBS}+75.0w_{CONV}+85.4w_{ER}+99.0w_{RB} - (5.19w_{TAC}+7w_{NU}) \leq 0 \quad (3.98)$$

$$(1-0.2)w_{LBS}+97.3w_{CONV}+94.2w_{ER}+99.0w_{RB} - (3.83w_{TAC}+7w_{NU}) \leq 0 \quad (3.99)$$

$$(1-0.2)w_{LBS}+97.0w_{CONV}+93.4w_{ER}+97.8w_{RB} - (3.71w_{TAC}+8w_{NU}) \leq 0 \quad (3.100)$$

$$(1-0.2)w_{LBS}+97.6w_{CONV}+89.9w_{ER}+99.1w_{RB} - (3.60w_{TAC}+8w_{NU}) \leq 0 \quad (3.101)$$

$$(1-0.2)w_{LBS}+97.7w_{CONV}+85.6w_{ER}+99.1w_{RB} - (3.57w_{TAC}+8w_{NU}) \leq 0 \quad (3.102)$$

$$(1-0.4)w_{LBS}+98.2w_{CONV}+90.6w_{ER}+99.1w_{RB} - (4.09w_{TAC}+7w_{NU}) \leq 0 \quad (3.103)$$

$$w_{TAC}, w_{NU}, w_{LBS}, w_{CONV}, w_{ER}, w_{RB} \geq 0 \quad (3.104)$$

The LP formulation for the Alternative 3 becomes;

$$\text{maximize } (1-0.2)w_{LBS}+97.6w_{CONV}+89.9w_{ER}+99.1w_{RB}$$

subject to:

$$3.60w_{TAC}+8w_{NU} = 1 \quad (3.105)$$

$$(1-0.5)w_{LBS}+75.0w_{CONV}+85.4w_{ER}+99.0w_{RB} - (5.19w_{TAC}+7w_{NU}) \leq 0 \quad (3.106)$$

$$(1-0.2)w_{LBS}+97.3w_{CONV}+94.2w_{ER}+99.0w_{RB} - (3.83w_{TAC}+7w_{NU}) \leq 0 \quad (3.107)$$

$$(1-0.2)w_{LBS}+97.0w_{CONV}+93.4w_{ER}+97.8w_{RB} - (3.71w_{TAC}+8w_{NU}) \leq 0 \quad (3.108)$$

$$(1-0.2)w_{LBS}+97.6w_{CONV}+89.9w_{ER}+99.1w_{RB} - (3.60w_{TAC}+8w_{NU}) \leq 0 \quad (3.109)$$

$$(1-0.2)w_{LBS}+97.7w_{CONV}+85.6w_{ER}+99.1w_{RB} - (3.57w_{TAC}+8w_{NU}) \leq 0 \quad (3.110)$$

$$(1-0.4)w_{LBS}+98.2w_{CONV}+90.6w_{ER}+99.1w_{RB} - (4.09w_{TAC}+7w_{NU}) \leq 0 \quad (3.111)$$

$$w_{TAC}, w_{NU}, w_{LBS}, w_{CONV}, w_{ER}, w_{RB} \geq 0 \quad (3.112)$$

The LP formulation for the Alternative 4 becomes;

$$\text{maximize } (1-0.2)w_{LBS}+97.7w_{CONV}+85.6w_{ER}+99.1w_{RB}$$

subject to:

$$3.57w_{TAC}+8w_{WNU} = 1 \quad (3.113)$$

$$(1-0.5)w_{LBS}+75.0w_{CONV}+85.4w_{ER}+99.0w_{RB} - (5.19w_{TAC}+7w_{WNU}) \leq 0 \quad (3.114)$$

$$(1-0.2)w_{LBS}+97.3w_{CONV}+94.2w_{ER}+99.0w_{RB} - (3.83w_{TAC}+7w_{WNU}) \leq 0 \quad (3.115)$$

$$(1-0.2)w_{LBS}+97.0w_{CONV}+93.4w_{ER}+97.8w_{RB} - (3.71w_{TAC}+8w_{WNU}) \leq 0 \quad (3.116)$$

$$(1-0.2)w_{LBS}+97.6w_{CONV}+89.9w_{ER}+99.1w_{RB} - (3.60w_{TAC}+8w_{WNU}) \leq 0 \quad (3.117)$$

$$(1-0.2)w_{LBS}+97.7w_{CONV}+85.6w_{ER}+99.1w_{RB} - (3.57w_{TAC}+8w_{WNU}) \leq 0 \quad (3.118)$$

$$(1-0.4)w_{LBS}+98.2w_{CONV}+90.6w_{ER}+99.1w_{RB} - (4.09w_{TAC}+7w_{WNU}) \leq 0 \quad (3.119)$$

$$w_{TAC}, w_{WNU}, w_{LBS}, w_{CONV}, w_{ER}, w_{RB} \geq 0 \quad (3.120)$$

The LP formulation for the Alternative 5 becomes;

$$\text{maximize } (1-0.4)w_{LBS}+98.2w_{CONV}+90.6w_{ER}+99.1w_{RB}$$

subject to:

$$4.09w_{TAC}+7w_{WNU} = 1 \quad (3.121)$$

$$(1-0.5)w_{LBS}+75.0w_{CONV}+85.4w_{ER}+99.0w_{RB} - (5.19w_{TAC}+7w_{WNU}) \leq 0 \quad (3.122)$$

$$(1-0.2)w_{LBS}+97.3w_{CONV}+94.2w_{ER}+99.0w_{RB} - (3.83w_{TAC}+7w_{WNU}) \leq 0 \quad (3.123)$$

$$(1-0.2)w_{LBS}+97.0w_{CONV}+93.4w_{ER}+97.8w_{RB} - (3.71w_{TAC}+8w_{WNU}) \leq 0 \quad (3.124)$$

$$(1-0.2)w_{LBS}+97.6w_{CONV}+89.9w_{ER}+99.1w_{RB} - (3.60w_{TAC}+8w_{WNU}) \leq 0 \quad (3.125)$$

$$(1-0.2)w_{LBS}+97.7w_{CONV}+85.6w_{ER}+99.1w_{RB} - (3.57w_{TAC}+8w_{WNU}) \leq 0 \quad (3.126)$$

$$(1-0.4)w_{LBS}+98.2w_{CONV}+90.6w_{ER}+99.1w_{RB} - (4.09w_{TAC}+7w_{WNU}) \leq 0 \quad (3.127)$$

$$w_{TAC}, w_{WNU}, w_{LBS}, w_{CONV}, w_{ER}, w_{RB} \geq 0 \quad (3.128)$$

The relative efficiencies are determined by solving the above LPs for each DMU using Excel Solver with ‘Assume Non-Negative’ and ‘Assume Linear Model’ choices selected, and with the “Precision” parameter of 10^{-6} . The results are given in the following table.

Table 3.18. Relative efficiencies and the optimal values of the weights for the alternative HDA flowsheets without value-judgment constraints

DMU	Efficiency	WTAC	WNU	WLBS	WCONV	WER	WRB
Base	1.00	0	0.142857	0	0	0	0.010091
Alt. 1	1.00	0	0.142857	0	0	0.000273	0.009841
Alt. 2	1.00	0.226100	0.020146	0	0.002976	0.007616	0
Alt. 3	1.00	0.190941	0.039076	0	0	0.001332	0.008882
Alt. 4	1.00	0.175562	0.046655	0	0	0	0.010091
Alt. 5	1.00	0	0.142857	0	0	0.000273	0.009841

All the DMUs are equally efficient; the ranking of efficiencies is not possible. This means that all of them are on the efficiency frontier; establishing a convex envelope. When the optimal weights are examined given in the Table 3.16, it is seen that most of them are zero. This means, there is no significance of these inputs or outputs in determination of the relative efficiencies. For example, especially the fractional loss of Benzene has no importance (w_{LBS} for all DMUs are zero). This may not be plausible for an engineer, so there should be some “value-judgment constraints” to reach a reasonable result.

3.2.2. DEA of the HDA Process with Value-Judgment Constraints

The values of the weights are judged and zero weights are detected. New constraints are added to the formulation, because the zero weights may not be acceptable for the HDA process from the engineering point of view.

3.2.2.1. Value Judgment with Bound Constraints on Weights: In this section the effect of lower-bound constraints on the input-output weights are studied. The aim is to completely avoid the possibility of getting zero optimal values for the weights. For this purpose the following lower bound constraints are examined, $w \geq 0.00001$, $w \geq 0.00010$, $w \geq 0.00100$, $w \geq 0.01000$, and $w \geq 0.003415$.

For the last one, the right-hand-side value of 0.003415 was found by trial and error as being the limit beyond which the HDA alternatives begin to show infeasibility. These side constraints are applied to all DMUs (HDA alternatives). Using Excel Solver with ‘Assume Non-Negative’ and ‘Assume Linear Model’ choices selected, and with the “Precision” parameter of 10^{-6} , the corresponding relative efficiencies for all DMUs and weights of the input and outputs are found by solving the LPs for all the DMUs individually on different Excel worksheets. With the $w \geq 0.01000$ constraint there is no feasible solution for any of the DMUs using Excel Solver. These calculated optimal relative efficiencies and the optimal weights are listed in Table 3.19 through Table 3.22.

Table 3.19. Relative efficiencies and optimal weights with the constraint $w \geq 0.00001$ for the alternative HDA flowsheets

DMU	Efficiency	WTAC	WNU	WLBS	WCONV	WER	WRB
Base	1.00	0.000010	0.142850	0.000010	0.000010	0.000010	0.010072
Alt. 1	1.00	0.000010	0.142852	0.000010	0.000010	0.000274	0.009830
Alt. 2	1.00	0.226117	0.020138	0.000010	0.002964	0.007618	0.000010
Alt. 3	1.00	0.190940	0.039077	0.000010	0.000010	0.001332	0.008872
Alt. 4	1.00	0.175681	0.046602	0.000010	0.000010	0.000010	0.010072
Alt. 5	1.00	0.000010	0.142851	0.000010	0.000010	0.000274	0.009830

Table 3.20. Relative efficiencies and optimal weights with the constraint $w \geq 0.00010$ for the alternative HDA flowsheets

DMU	Efficiency	WTAC	WNU	WLBS	WCONV	WER	WRB
Base	1.00	0.000100	0.142783	0.000100	0.000100	0.000100	0.009899
Alt. 1	1.00	0.000100	0.142802	0.000100	0.000100	0.000283	0.009733
Alt. 2	1.00	0.226272	0.020066	0.000100	0.002853	0.007638	0.000100
Alt. 3	1.00	0.190926	0.039083	0.000100	0.000100	0.001334	0.008781
Alt. 4	1.00	0.176750	0.046125	0.000100	0.000100	0.000100	0.009905
Alt. 5	1.00	0.000100	0.142799	0.000100	0.000100	0.000283	0.009733

Table 3.21. Relative efficiencies and optimal weights with the constraint $w \geq 0.00100$ for the alternative HDA flowsheets

DMU	Efficiency	WTAC	WNU	WLBS	WCONV	WER	WRB
Base	1.00	0.000100	0.142783	0.000100	0.000100	0.000100	0.009899
Alt. 1	1.00	0.000100	0.142802	0.000100	0.000100	0.000283	0.009733
Alt. 2	1.00	0.226272	0.020066	0.000100	0.002853	0.007638	0.000100
Alt. 3	1.00	0.190926	0.039083	0.000100	0.000100	0.001334	0.008781
Alt. 4	1.00	0.176750	0.046125	0.000100	0.000100	0.000100	0.009905
Alt. 5	1.00	0.000100	0.142799	0.000100	0.000100	0.000283	0.009733

Table 3.22. Relative efficiencies and optimal weights with the constraint $w \geq 0.003415$ for the alternative HDA flowsheets

DMU	Efficiency	WTAC	WNU	WLBS	WCONV	WER	WRB
Base	0.89	0.003415	0.140325	0.003415	0.003415	0.003415	0.003421
Alt. 1	1.00	0.003415	0.140989	0.003415	0.003415	0.003415	0.003468
Alt. 2	0.99	0.168445	0.046883	0.003415	0.003415	0.003415	0.003415
Alt. 3	1.00	0.203382	0.033478	0.003415	0.003415	0.003415	0.003602
Alt. 4	0.99	0.272459	0.003415	0.003415	0.003689	0.003415	0.003415
Alt. 5	0.99	0.003415	0.140862	0.003415	0.003459	0.003415	0.003415

The effects of the absence and presence of the value judgment constraints as lower bounds on the weights, and the effects of the right-hand-side values on the relative efficiency ranking of the HDA alternatives are summarized in Table 3.23.

Table 3.23. Effects of the value judgment constraints as lower bounds for HDA

Relative Efficiency Ranking of DMUs				
$w \geq 0$ (No VJ)	$w \geq 0.00001$	$w \geq 0.00010$	$w \geq 0.000100$	$w \geq 0.003415$
Base 1.00	Base 1.00	Base 1.00	Base 1.00	Alt. 1 1.00
Alt. 1 1.00	Alt. 1 1.00	Alt. 1 1.00	Alt. 1 1.00	Alt. 3 1.00
Alt. 2 1.00	Alt. 2 1.00	Alt. 2 1.00	Alt. 2 1.00	Alt. 2 0.99
Alt. 3 1.00	Alt. 3 1.00	Alt. 3 1.00	Alt. 3 1.00	Alt. 4 0.99
Alt. 4 1.00	Alt. 4 1.00	Alt. 4 1.00	Alt. 4 1.00	Alt. 5 0.99
Alt. 5 1.00	Alt. 5 1.00	Alt. 5 1.00	Alt. 5 1.00	Base 0.89

3.2.2.2. Value-Judgment with Equality or Inequality Constraints on Input/Output Weights:

In this section the effect of inequality constraints between various input and output weights are studied. For this purpose the following inequalities are examined.

$$i) \quad w_{TAC} \geq w_{LBS}$$

This value judgment constraint signifies that total annual cost may be judged to be more important than loss of Benzene in stabilizer for all HDA alternatives.

$$ii) \quad w_{NHEX} \geq w_{NHU}$$

Since the product of HDA plant is Benzene, this value judgment constraint signifies that the recovery of Benzene may be judged to be more important than the conversion for all HDA alternatives.

$$iii) \quad w_{ER} = w_{RB}$$

This value judgment constraint signifies that energy recovery and recovery of Benzene are equally important.

$$iv) \quad w_{TAC} \geq w_{LBS}$$

$$w_{RB} \geq w_{CONV}$$

$$w_{RB} \geq w_{ER}$$

These value judgment constraints signify that the total annual cost may be judged to be more important than loss of Benzene in stabilizer; since the product of HDA plant is Benzene, the recovery of Benzene may be more important than the conversion; energy recovery is more important than the recovery of Benzene for all HDA alternatives, respectively.

Using Excel Solver with ‘Assume Non-Negative’ and ‘Assume Linear Model’ choices signed, and with the “Precision” parameter of 10^{-6} , the corresponding relative efficiencies for all DMUs and weights of the input and outputs are found by solving the LPs for all the DMUs individually on different Excel worksheets. These calculated optimal relative efficiencies and the optimal weights are listed in Table 3.24 through Table 3.27.

Table 3.24. Relative efficiencies and optimal weights for the alternative HDA flowsheets with value-judgment constraint $w_{TAC} \geq w_{LBS}$

DMU	Efficiency	w_{TAC}	w_{NU}	w_{LBS}	w_{CONV}	w_{ER}	w_{RB}
Base	1.00	0	0.142857	0	0	0	0.010091
Alt. 1	1.00	0	0.142857	0	0	0.000273	0.009841
Alt. 2	1.00	0.226100	0.020146	0	0.002976	0.007616	0
Alt. 3	1.00	0.191179	0.038970	0.191179	0	0.001334	0.007338
Alt. 4	1.00	0.175562	0.046655	0	0	0	0.010091
Alt. 5	1.00	0	0.142857	0	0	0.000273	0.009841

Table 3.25. Relative efficiencies and optimal weights for the alternative HDA flowsheets
with value-judgment constraint $w_{RB} \geq w_{CONV}$

DMU	Efficiency	w_{TAC}	w_{NU}	w_{LBS}	w_{CONV}	w_{ER}	w_{RB}
Base	1.00	0	0.142857	0	0	0	0.010091
Alt. 1	1.00	0	0.142857	0	0	0.000273	0.009841
Alt. 2	1.00	0.228418	0.019071	0	0.001342	0.007907	0.001342
Alt. 3	1.00	0.190941	0.039076	0	0	0.001332	0.008882
Alt. 4	1.00	0.175562	0.046655	0	0	0	0.010091
Alt. 5	1.00	0	0.142857	0	0	0.000273	0.009841

Table 3.26. Relative efficiencies and optimal weights for the alternative HDA flowsheets
with value-judgment constraint $w_{RB} = w_{ER}$

DMU	Efficiency	w_{TAC}	w_{NU}	w_{LBS}	w_{CONV}	w_{ER}	w_{RB}
Base	0.95	0	0.142857	0	0	0.005176	0.005176
Alt. 1	1.00	0	0.142857	0	0.006804	0.001750	0.001750
Alt. 2	0.99	0.211467	0.026932	0	0	0.005168	0.005168
Alt. 3	1.00	0.189816	0.039583	0	0.007350	0.001495	0.001495
Alt. 4	1.00	0.171194	0.048605	0	0.010235	0	0
Alt. 5	1.00	0.035250	0.122261	0	0.010183	0	0

Table 3.27. Relative efficiencies and optimal weights for the alternative HDA flowsheets with value-judgment constraints $w_{TAC} \geq w_{LBS}$, $w_{RB} \geq w_{CONV}$, $w_{RB} \geq w_{ER}$

DMU	Efficiency	w_{TAC}	w_{NU}	w_{LBS}	w_{CONV}	w_{ER}	w_{RB}
Base	1.00	0	0.142857	0	0	0	0.010091
Alt. 1	1.00	0	0.142857	0	0.004495	0.001249	0.004495
Alt. 2	0.99	0.211467	0.026932	0	0	0.005168	0.005168
Alt. 3	1.00	0.191179	0.038970	0.191179	0	0.001334	0.007338
Alt. 4	1.00	0.175562	0.046655	0	0	0	0.010091
Alt. 5	1.00	0.010946	0.136462	0.010946	0.005035	0	0.005035

The effects of the absence and presence of the value judgment constraints as equalities or inequalities of the input and output weights on the relative efficiency ranking of the HDA alternatives are summarized in Table 3.28.

Table 3.28. Effects of the value judgment equality or inequality constraints for HDA

Relative Efficiency Ranking of DMUs				
No VJ $w \geq 0$	$w_{TAC} \geq w_{LBS}$	$w_{NHEX} \geq w_{NHU}$	$w_{ER} = w_{RB}$	$w_{TAC} \geq w_{LBS}$, $w_{RB} \geq w_{CONV}$, $w_{RB} \geq w_{ER}$
Base 1.00	Base 1.00	Base 1.00	Alt. 1 1.00	Base 1.00
Alt. 1 1.00	Alt. 1 1.00	Alt. 1 1.00	Alt. 1 1.00	Alt. 1 1.00
Alt. 2 1.00	Alt. 2 1.00	Alt. 2 1.00	Alt. 4 1.00	Alt. 3 1.00
Alt. 3 1.00	Alt. 3 1.00	Alt. 3 1.00	Alt. 5 1.00	Alt. 4 1.00
Alt. 4 1.00	Alt. 4 1.00	Alt. 4 1.00	Alt. 2 0.99	Alt. 5 1.00
Alt. 5 1.00	Alt. 5 1.00	Alt. 5 1.00	Base 0.95	Alt. 2 0.99

As it can be seen from Table 3.28, HDA alternatives are almost insensitive to the value-judgment equalities or inequalities introduced on the input weights; their relative efficiency values do not change. HDA alternatives; Alt. 2 and Base are only moderately sensitive to the value-judgment equalities or inequalities introduced on the input and output

weights. If Table 3.18 and Tables 3.24 through 3.27 are examined for the optimal weights, it is seen that w_{CONV} values are the ones most affected by the introduction of $w_{ER} = w_{RB}$ constraint.

3.2.2.3 Value-Judgment with Inequality Constraints on Output Weights with Multipliers:

In this section the effects of the integer multipliers in inequality constraints between output weights are studied. For this purpose the following inequalities are examined individually: $w_{RB} \geq 2 \times w_{ER}$, $w_{RB} \geq 10 \times w_{ER}$, and $w_{RB} \geq 100 \times w_{ER}$. These constraints signify that, for example, energy recovery may be judged to be two times more important than the recovery of Benzene, etc. The effects of integer multipliers are studied for the inequality between w_{RB} and w_{ER} since the results of the previous section (Table 3.28) show that $w_{ER} = w_{RB}$ constraint is the most effective one.

Using Excel Solver with ‘Assume Non-Negative’ and ‘Assume Linear Model’ choices selected, and with the “Precision” parameter of 10^{-6} , the corresponding relative efficiencies for all DMUs and weights of the input and outputs are found by solving the LPs for all the DMUs individually on different Excel worksheets. These calculated optimal relative efficiencies and the optimal weights are listed in Table 3.29 through Table 3.31.

Table 3.29. Relative efficiencies and optimal weights with the constraint $w_{RB} \geq 2 \times w_{ER}$

DMU	Efficiency	w_{TAC}	w_{NU}	w_{LBS}	w_{CONV}	w_{ER}	w_{RB}
Base	1.00	0	0.142857	0	0	0	0.010091
Alt. 1	1.00	0.189235	0.039319	0	0.005901	0.001457	0.002915
Alt. 2	0.98	0.200242	0.032138	0	0	0.003395	0.006789
Alt. 3	1.00	0.190034	0.039485	0	0.005926	0.001464	0.002927
Alt. 4	1.00	0.175562	0.046655	0	0	0	0.010091
Alt. 5	1.00	0	0.142857	0	0	0	0.010091

Table 3.30. Relative efficiencies and optimal weights with the constraint $w_{RB} \geq 10 \times w_{ER}$

DMU	Efficiency	w_{TAC}	w_{NU}	w_{LBS}	w_{CONV}	w_{ER}	w_{RB}
Base	1.00	0	0.142857	0	0	0	0.010091
Alt. 1	1.00	0	0.142857	0	0.002116	0.000732	0.007324
Alt. 2	0.98	0.172712	0.044905	1.219775	0	0	0
Alt. 3	1.00	0.185943	0.041325	0	0	0.000924	0.009237
Alt. 4	1.00	0.171194	0.048605	0	0.010235	0	0
Alt. 5	1.00	0	0.142857	0	0	0.000273	0.009841

Table 3.31. Relative efficiencies and optimal weights with the constraint $w_{RB} \geq 100 \times w_{ER}$

DMU	Efficiency	w_{TAC}	w_{NU}	w_{LBS}	w_{CONV}	w_{ER}	w_{RB}
Base	1.00	0	0.142857	0	0	0	0.010091
Alt. 1	1.00	0.002463	0.141510	0	0	0.000100	0.010006
Alt. 2	0.98	0.172712	0.044905	1.219775	0	0	0
Alt. 3	1.00	0.175860	0.045863	0	0	0.000100	0.009952
Alt. 4	1.00	0.176793	0.046106	0	0	0.000100	0.010004
Alt. 5	1.00	0	0.142857	0	0	0.000100	0.009999

The effects of the integer multipliers in value judgment inequality constraints of the output weights on the relative efficiency ranking of the HDA alternatives are summarized in Table 3.32.

Table 3.32. Effects of the value judgment inequality constraint multipliers

Relative Efficiency Ranking of DMUs			
No VJ $w \geq 0$	$w_{RB} \geq 2 \times w_{ER}$	$w_{RB} \geq 10 \times w_{ER}$	$w_{RB} \geq 100 \times w_{ER}$
Base 1.00	Base 1.00	Base 1.00	Base 1.00
Alt. 1 1.00	Alt. 1 1.00	Alt. 1 1.00	Alt. 1 1.00
Alt. 2 1.00	Alt. 3 1.00	Alt. 3 1.00	Alt. 3 1.00
Alt. 3 1.00	Alt. 4 1.00	Alt. 4 1.00	Alt. 4 1.00
Alt. 4 1.00	Alt. 5 1.00	Alt. 5 1.00	Alt. 5 1.00
Alt. 5 1.00	Alt. 2 0.98	Alt. 2 0.98	Alt. 2 0.98

As it can be seen from Table 3.32, almost all HDA alternatives are totally insensitive to the value of the integer multiplier in value-judgment inequalities introduced on the output weights; only the relative efficiency of Alt. 2 value changes. Compared to nominal case (no value judgment) the presence of the inequality $w_{RB} \geq n \times w_{ER}$ is effective but the value of the multiplier n is not so much important.

As the results of the additions of the value-judgment constraints as well as the side constraints on the weights show, the DEA may be quite subjective. There are almost infinitely many more possibilities for the value-judgment constraints. As demonstrated here, the addition of value-judgment constraints may or may not have significant effect on the final result, i.e., the relative efficiency ranking of the DMUs. This may be seen as the weakness of DEA. However, this flexibility of imposing value judgments may also be considered as the strength of the DEA. The chemical process design is considered to have an art part, which is subjective, as well a science part. The art part of the design is what makes it “state-of-the-art”. Similarly, the DEA with value judgment may also be considered as the “state-of-the-art”; the science part coming from the LP formulation and the art part due to value-judgment constraints.

Anyway, the DEA enables the determination of the efficiency of the HDA alternative(s) under multi input-output conditions. Without the DEA, it is hard or

impossible to rank efficiencies by just looking at the individual input-output relationships for each HDA alternative one by one.

4. CONCLUSIONS AND RECOMMENDATIONS

In this thesis, two new examples of Data Envelopment Analysis (DEA) were investigated as the first examples of DEA related to chemical engineering. One of these examples deals with the Heat Exchanger Networks (HENs) and the second one deals with the alternative flowsheet proposals for the Hydrodealkylation of toluene (HDA) process. The Constant Returns-to-Scale (CRS) model of DEA was selected for the calculations.

The aim was to evaluate (rank) the relative efficiencies of the alternative HEN structures and the alternative HDA flowsheets using the DEA method. First, the Decision Making Units (DMUs), inputs and outputs of the examples were defined. Then, the DEA formulations were developed by considering the inputs and outputs. The DEA formulations were converted to Linear Programming (LP) forms. The LP problems were solved using the Excel Solver. For the both examples, the efficiency results and the weights of the inputs and outputs were judged. Since the weights were not satisfactory for an engineer, some logical constrictions, known as the value-judgment constraints, were added to get more plausible results. Since it is generally hard, or even impossible, to decide on the efficiency of a member or group of members (DMUs) utilizing a simple graphical technique under multiple inputs and outputs, the DEA is a good method to evaluate and rank relative efficiencies.

One of the distinguishing features of DEA is that the units (kg, ton, Joule, kW, ...) of the data are not important during the application of the model. The input and output data may have the same or the different units. Only the data are enough to apply the model, no further process model is necessary. It is also possible to increase and decrease the number of inputs and outputs. There is not any specific restriction for the numbers of inputs, outputs, and DMUs. The flexibility of imposing additional constraints (value-judgment constraints) is a good feature; although such constraints may be considered as subjective, they provide great flexibility in the analyses. On the other hand, any errors (uncertainties) in the supplied data may cause significant deviations from the reality. This means, one should know the details of the problem at hand while applying the DEA.

The additions of value-judgment constraints as well as side constraints on the weights show that the DEA results may be quite subjective. There are almost infinitely many more possibilities for the value-judgment constraints. As demonstrated in this thesis, the addition of value-judgment constraints may or may not have significant effect on the final result, i.e., the relative efficiency ranking of the DMUs. This may be seen as the weakness of DEA. However, this flexibility of imposing value judgments may also be considered as the strength of the DEA. The chemical process design is considered to have an art part, which is subjective, as well a science part. The art part of the design is what makes it “state-of-the-art”. Similarly, the DEA with value judgment may also be considered as the “state-of-the-art”; the science part coming from the LP formulation and the art part due to value-judgment constraints.

Nevertheless, the DEA enables the determination of the most efficient HEN structure(s) or alternative HDA flowsheet(s) under multi input multi output conditions. Without the DEA, it is hard or impossible to decide on by just looking at the individual input-output relationships for each HEN structure or HDA flowsheet alternative one by one.

As recommendations for further works on the application of the DEA to Chemical Engineering problems one may conceive the followings:

- The problems with more DMUs should be created and tested. This can be done by generating other process alternatives either by original means (e.g., solution of MILP model for HENs) or by generating fictitious / random cases around the nominal cases via Monte-Carlo sampling/simulation techniques.
- The DEA objective (efficiency ranking of the alternatives) and the associated constraints may be embedded into process-synthesis formulations (optimization models) in order to simultaneously or sequentially synthesize and efficiency-rank the alternatives. Although optimal process synthesis and design problems are difficult and time consuming to solve due to nonlinear nature of the chemical engineering systems, their efficiency ranking step via DEA should not impose significant burden due to solvability of basic DEA as LP problem.

- In this thesis the constant returns-to-scale (CRS) assumption is used in the DEA models. Chemical Engineering examples that necessitate the use of the variable returns-to-scale (VRS) based DEA should be derived and tested.
- Other, more advanced, DEA formulations (e.g., the ones that enforce common weights to all DMUs) should be tested for the alternative HEN structures and alternative HDA flowsheets examples.
- In this thesis work, the Excel Solver is used to solve the resulting LP formulations of the DEA examples. For further studies with many more DMUs, inputs, and outputs, the use of Matlab or GAMS for the solution of the DEA models may be beneficial.

REFERENCES

- Beasley, J. E., 1996, *OR-Notes: Data Envelopment Analysis*, Brunel University, UK, <http://people.brunel.ac.uk/~mastjib/jeb/or/dea.html>
- Charnes, A., W. W. Cooper, E. L. Rhodes, 1978, “*Measuring the efficiency of decision making units*”, *European Journal of Operational Research*, 2, pp. 429-444.
- Cook, W. D., L. M. Seiford, 2009, “*Data envelopment analysis (DEA)-Thirty years on*”, *European Journal of Operational Research*, 192, pp. 1-17.
- Cooper, W. W., L. M. Seiford and J. Zhu, 2004, “*Handbook on Data Envelopment Analysis*”, Kluwer Academic Publishers.
- Douglas, M. J., 1988, “*Conceptual Design of Chemical Processes*”, University of Massachusetts, pp. 289-315.
- Farrell, M. J., 1957, “*The measurement of productive efficiency*”, *J. Royal Statis. Soc. Series A*, 120, pp. 253-281.
- Farrell, M. J., M. Fieldhouse, 1962, “*Estimating efficient production functions under increasing returns to scale*”, *J. Royal Statis. Soc. Series A*, 125, pp. 252-267.

REFERENCES NOT CITED

- Aggarwal, V., “*Performance Analysis of Large Canadian Banks Over Time Using DEA*”, M.Sc. Thesis in University of Toronto, 1996.
- Coelli, T. J., D. S. P. Rao, C. J. O’Donnell and G. E. Battese, “*An Introduction to Efficiency and Productivity Analysis*”, Springer Science and Business Media, Inc., 2005.
- Cooper, W. W., L. M. Seiford and K. Tone, “*Data Envelopment Analysis-A Comprehensive Text with Models, Applications, References and DEA-Solver Software*”, Springer Science and Business Media, LLC, 1988.
- Cooper, W. W., L. M. Seiford and K. Tone, “*Introduction to Data Envelopment Analysis and Its Uses*”, Springer Science and Business Media, Inc., 2006.
- Emrouznejad, A., *DEA Home Page*, Warwick Business School, UK, 1995-2001, <http://deazone.com/tutorial/the.htm>
- Mohammad, R. A., “*Sampling size and efficiency bias in data envelopment analysis*”, *Journal of Applied Mathematics & Decision Sciences*, 2(1), pp. 51-64, 1998.
- Ray, S. C. “*Comparing Input- and Output-Oriented Measures of Technical Efficiency to Determine Local Returns to Scale in DEA Models*”, University of Connecticut Economics Working Papers, 2008.
- Ray, S. C., “*Data Envelopment Analysis-Theory and Techniques for Economics and Operations Research*”, Cambridge University Press, 2004.

Zhou, P., B. W. Ang, K. L. Poh, “A *survey of data envelopment analysis in energy and environmental studies*”, *European Journal of Operational Research*, 189, pp. 1-18, 2008.