

FOR REFERENCE

NOT TO BE TAKEN FROM THIS ROOM

DATA ACQUISITION SYSTEM

by

SABRİ METİN İSKİT

Bogazici University Library



39001100316366

14

Submitted to

The Faculty of the School of Engineering  
in Partial Fulfilment of the Requirements for  
the Degree of Master of Science  
in Electrical Engineering.

BOĞAZIÇI UNIVERSITY

September 1981

## ACKNOWLEDGEMENTS

The following is not the work of a single person, but it has been realized with the helps of many individuals.

At the first stage, I would like to express my sincere gratitude for the thesis supervisors, Prof. Dr. Sabih Tansal and Doç. Dr. Bülent Sankur.

I would also like to thank Dr. Ömer Cerid for his valuable suggestions on the design.

Also, I am very thankful to ÇNAEM Electronic Department for their help in practical realisation of the instrument.

## ABSTRACT

In this study several analog to digital converter systems are described and their advantages and disadvantages are told. Among them, a successive approximation type one is designed and built. To obtain flexibility, it is designed as a bus compatible device. Also device addressing is used, by use of which, more similar devices will be able to be connected to the bus. The bus is so designed that it is not possible for more than one pair of devices to be active on it at any time. The system also has analog multiplexing facility which selects one of eight analog inputs. This selection can either be done by the peripheral device or by the system itself, according to the information on the bus. Output of the system is 12 bits, in addition to the parallel output, serial output with preselectable baud rate is put for long distance communication. The results obtained are quite satisfactory in performance.

## TABLE OF CONTENTS

ACKNOWLEDGEMENTS	1
ABSTRACT	2
TABLE OF CONTENTS	3
LIST OF FIGURES	5
PREFACE	7
PRINCIPLES OF ADC SYSTEMS	9
Single Slope ADC	9
Single Slope ADC with DAC Feedback	11
Dual Slope ADC	13
Voltage to Frequency Converter ADC	16
Successive Approximation ADC	17
Flash ADC	19
Parallel Ripple ADC	21
Variable Treshold Flash ADC	22
Wilkinson ADC	24
Dual Ramp ADC	24
Comparison Table Of ADC's	26
GENERAL DESCRIPTION OF THE BUS	
AND THE BUS COMPATIBLE ADC	27

PRINCIPLE OF OPERATION	30
Address sense	32
State Information	32
Bit Selector	33
Addressed Reset	34
Bit Memory Array	34
Parallel to Serial Converter	36
Bus Buffer	37
Channel Incrementer	37
Channel Selector	37
Analog Section	38
DAC	40
RESULTS AND CONCLUSION	43
COMPLETE CIRCUIT DIAGRAMS	46
WAVEFORMS OF ADC	51
TECHNICAL SPECIFICATIONS	52
COMPONENTS LIST	53
APPENDIX A	
Interfacing with a Microprocessor	55
APPENDIX B	
Sample Program for 8085	57
REFERENCES	62

## LIST OF FIGURES

Fig 1	Single Slope ADC	9
Fig 2	Single Slope ADC with DAC Feedback	12
Fig 3 a	Dual Slope ADC	13
Fig 3b	Waveforms of Dual Slope ADC	14
Fig 4	Precise Dual Slope ADC	15
Fig 5	Successive Approximation ADC	17
Fig 6	Waveforms of Successive Approximation ADC	19
Fig 7	Flash ADC	20
Fig 8	Parallel Ripple ADC	22
Fig 9	Variable Treshold Flash ADC	23
Fig 10	Wilkinson ADC	23
Fig 11	Dual Ramp ADC	25
Fig 12	Block Diagram of the DAS	31
Fig 13	Address Sence Circuit	32
Fig 14	State Information Circuit	33
Fig 15	Bit Selector Circuit	34
Fig 16	Addressed Reset and Bit Memory Array Circuit	35
Fig 17	Parallel to Serial Converter Circuit	35

Fig 18	Bus Buffer Circuit	36
Fig 19	Channel Incrementer and Channel Selector Circuit	37
Fig 20	Analog Section Circuitry	39
Fig 21	DAC Circuitry	40

Complete Circuit Diagrams

Digital Part, Input/Output Circuit	46
Digital Part, Successive Approximation Register Circuit	47
Analog Multiplexer and Sample and Hold Circuit	48
Digital to Analog Converter Circuit	49
Power Supply Circuit	50
Waveforms of ADC	51

## PREFACE

In the last years, after the power of digital systems are distinguished, the digital measuring instruments became to play a very important role in industry. Beginning with the simplest digital voltmeters, more precise analog to digital converters were made and finally they became unavoidable interfaces of digital computers and microprocessors. During this evolution, many approaches were made to obtain the cheapest and the most powerful conversion systems. Some of the basic types are discussed in this thesis.

The choice among these types of ADC's in this thesis is the successive approximation type which is the second fastest type of the converters. Principally it performs the conversion in  $K \times N$  clock pulses where  $N$  is the number of bits and  $K$  is the number of clock pulses required to decide the state of the corresponding bit. It is easier to choose  $K$  as 2 or more to simplify the design, but to obtain maximum conversion speed, it is tried to keep  $K$  as 1 and successful results are obtained.

To increase the flexibility of the ADC, it is designed as a bus compatible device with multiplexed 8 analog inputs. The

ADC will be a service unit on the bus, and of course at least one consumer unit must also be present. The channel number of analog inputs can either be identified by this consumer device or can be left free such that it increases by one each time a service request comes. To be able to connect more than one service unit on the bus, a two bits service unit address line is added, so, three service units can be connected to the bus. Also for long distance communication, a variable baud rate serial output is added. The detailed description of the operation of the bus and the system will be given in the text.

Neither part of this design is directly copied from any reference. The references are used to get information about the operations of the individual subsystems used in the circuit, so it is possible that the diagrams cannot be found in the references given.

## PRINCIPLES OF ADC SYSTEMS

In this section, several types of analog to digital converters will be discussed. These are single slope, dual slope, successive approximation, flash, voltage to frequency, Wilkinson and dual ramp ADC's.

The single slope ADC is the simplest of the present systems. It has one comparator which compares a ramp with the input voltage and measures the time for the ramp to reach this voltage. This time, when multiplied by a constant, gives the value of the input voltage.

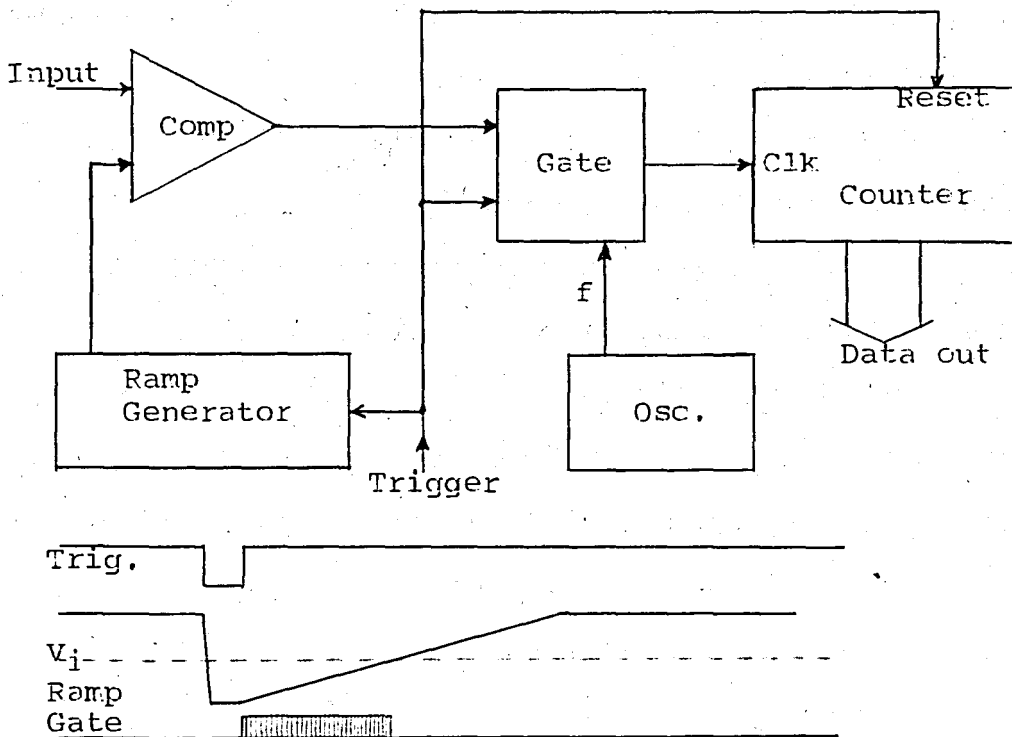

Figure 1: Block diagram and the waveforms of a single slope ADC.

At steady state, ramp generator output is at its highest value and the gate is closed (i.e. no signal is present at the output of the gate). When trigger signal goes low, the counter is reset and the gate is kept closed, also the ramp generator output is set to zero volt. At the time the trigger signal goes high the gate is opened and the counter begins to count the incoming pulses. During this time the ramp output increases, and when it reaches the analog input voltage, the comparator changes its state and closes the gate. The number of counts gives the voltage for appropriate choice of the oscillator frequency. To read the next sample, trigger signal must go low and then high again.

As can easily be seen, the slope of the ramp generator, the frequency of the oscillator and the number of bits are closely related to each other. The number of bits,  $N$ , will be chosen according to the design specifications. To give a realistic example, for a 12 bit converter, a convenient full scale voltage will be 4.096 volts, each step corresponding to one millivolt. Let the maximum number of conversions per second be  $N$ . Then, it means that 4096 pulses are required to be counted in  $1/N$  seconds. So the necessary oscillator frequency must be  $4096 \times N$  cycles per second. Also in  $1/N$  seconds, ramp must reach to its maximum value of 4.096 volts, so the slope of the ramp generator must be  $4.096 \times N$  volts/second. By use of these data, an appropriate

oscillator and an integrator (as the ramp generator) can be designed. Since the limitation mostly comes from the comparator, for which we have to take the propagation delay to be less than the period of the oscillation, by choosing a quite high value for the oscillator frequency such as 2 MHz, we find

$$N = 2000000 / 4096 \approx 500 \text{ conversions/second,}$$

which is quite unsatisfactory for most systems. This is why these types of systems are used as digital voltmeters where only a few conversions/second are necessary instead of fast computer interfaces.

One important problem also arises in hardware design, which is setting the ramp generator voltage to zero volt before beginning of counting. This is because of the offset voltages and/or the saturation voltages and on state resistances of the components used. Besides this uncertainties, a small deviation in oscillator frequency or in the slope of the ramp results in an error. To overcome these two errors, a feedback type single slope ADC can be designed by use of a digital to analog converter (DAC) as shown in figure 2.

In this type of ADC, trigger pulse only resets the counter. The all zero output of the counter causes the output of the DAC to be at zero volt, and comparator opens the gate. Each pulse the counter counts increases the output voltage of the DAC by

one least significant bit (LSB) voltage, e.g. if full scale voltage is 4.096 volts for a 12 bit ADC, each pulse increases the voltage by one millivolt. So, a staircase type ramp is obtained directly dependent on the total number of counts. This eliminates the uncertainty coming from zero volt start of the ramp generator and independent deviations of the clock frequency and the ramp voltage slopes. But the setup time of the DAC, which is usually much greater than the propagation delay of the comparator and the propagation delay of the counter are added to the propagation delay of the comparator, which reduces the speed considerably. Also since the DAC is the most expensive component of this system, financial problems may arise.

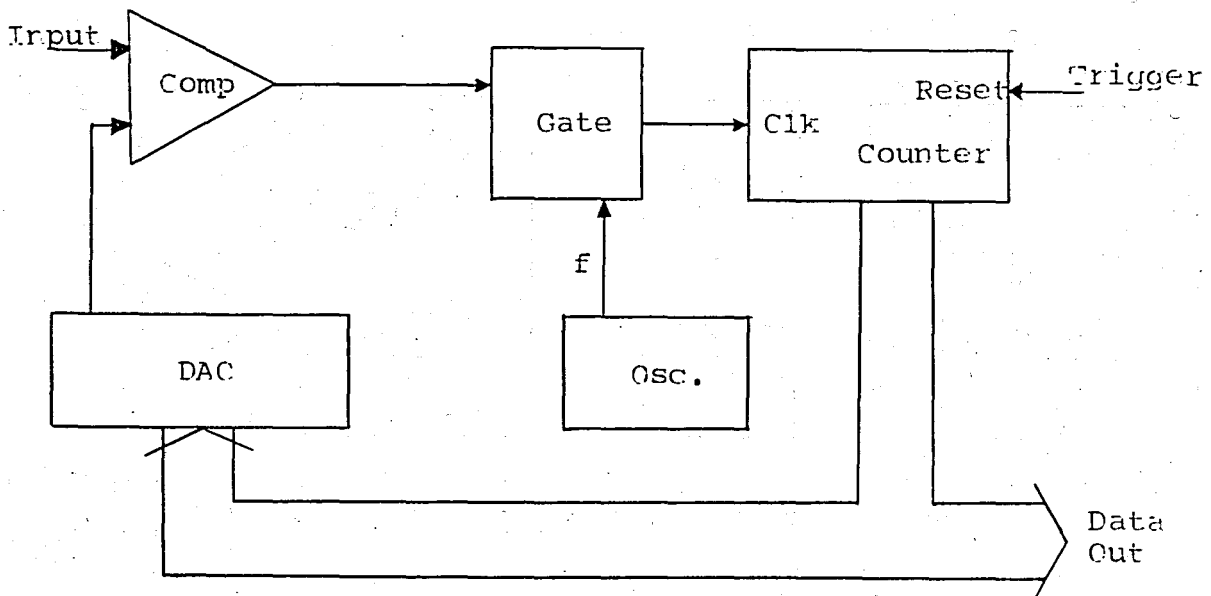

Figure 2: Single slope ADC with DAC feedback

Dual slope ADC is the type which overcomes the problem of zero volt start of the ramp generator <sup>by</sup> without using a DAC but instead a second comparator. When it is desired to take a sample, the memory element ME1 is set by a trigger pulse. This causes the output of the ramp generator to increase (by any slope which is not important). When it reaches the input voltage, comparator 1 sets ME2 which opens the gate and resets ME1 which turns ramp generator output to a known negative slope waveform. The counter counts until the ramp voltage falls to zero volt, at that time comparator 2 resets ME2 and closes the gate. After the gate is closed, ramp output will continue to fall down to the saturation voltage specified by the designer, which is a negative voltage, and waits until next trigger pulse.

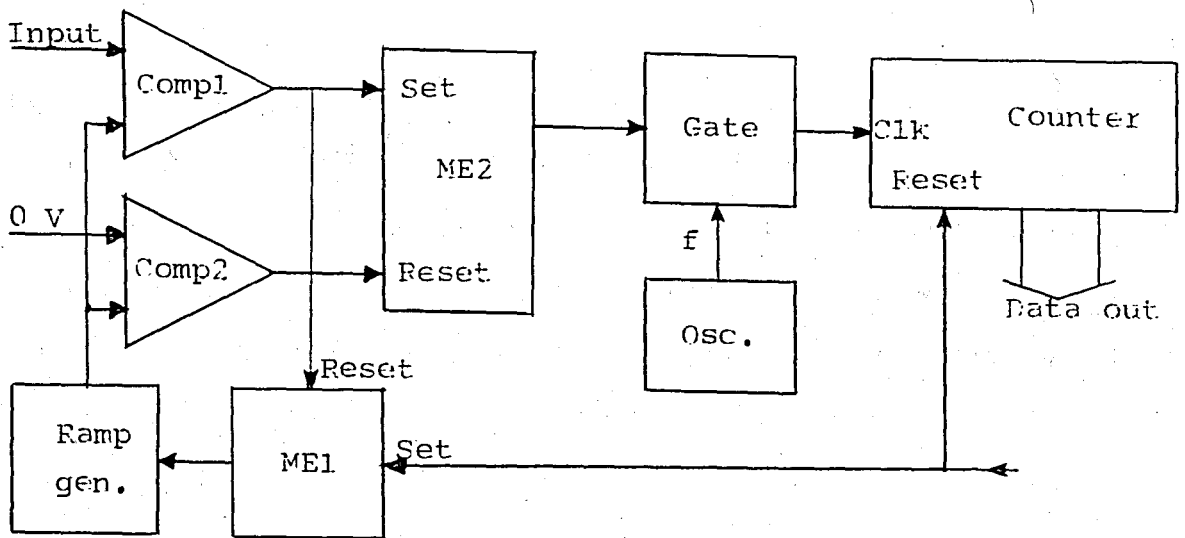

Figure 3:a) Block diagram of a dual slope ADC

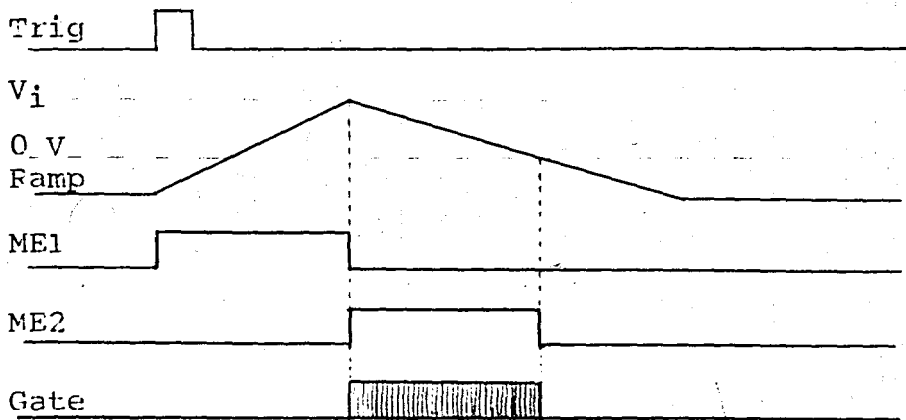

Figure 3:b) Waveforms of a dual slope ADC

Since two sweeps are used for one conversion, it is obvious that maximum conversions per second will decrease to about half the value of the single slope systems. In fact for double slope systems, propagation delay of the memory elements are added, so the speed becomes less than what is expected.

But for this system again the clock frequency and the slope of the ramp generator can vary independently, so enough precision cannot be obtained. It is possible to control one of the slopes by use of the input voltage as shown in figure 4. For this circuit, the trigger pulse resets the counter and sets the ME which switches the single pole double throw (SPDT) analog switch to the analog input voltage. The integrator output begins to increase, and when it passes through zero volt, it opens the gate by use of the comparator. From now on, the counter counts until it reaches its maximum value, sends

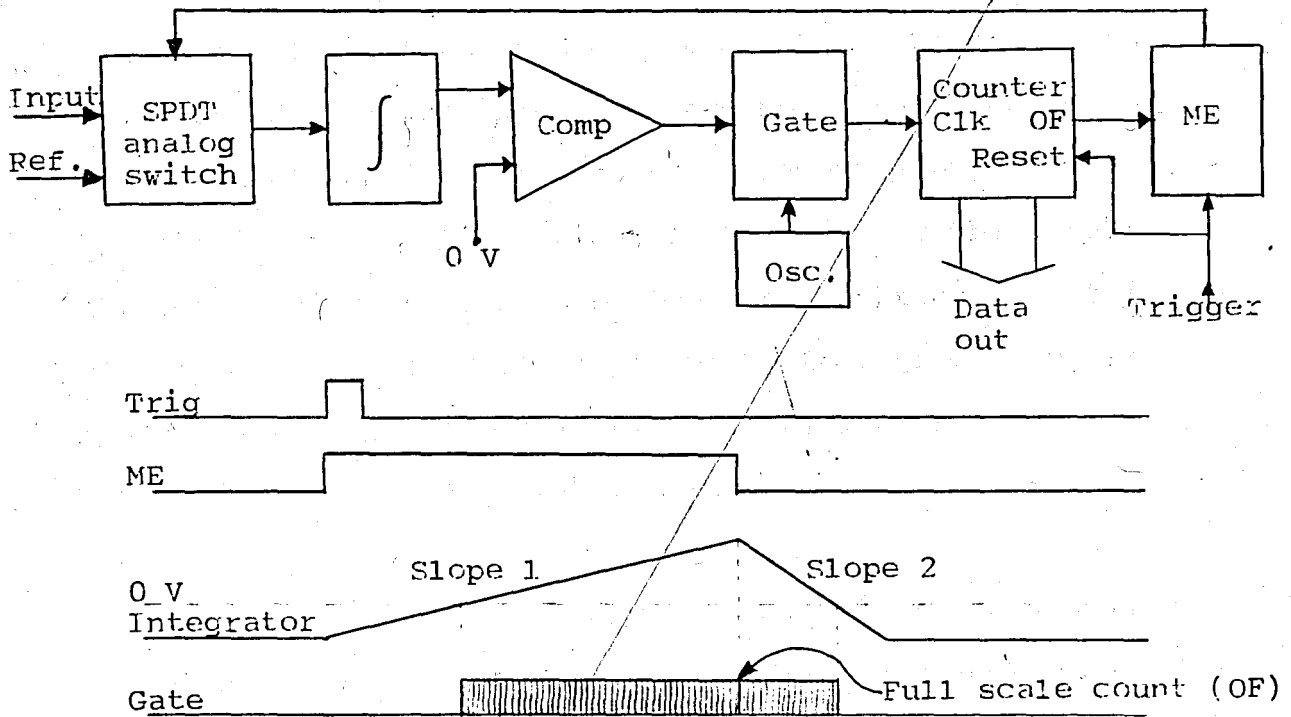

Figure 4: Block diagram of a precise dual slope ADC

an overflow (OF) to reset ME and begins to count beginning from zero again. The ME switches the SPDT switch to the reference voltage. At this time, the output voltage of the integrator is proportional to the slope of the ramp (slope 1) which is also proportional to the input voltage. The reference voltage causes the output voltage of the integrator to fall down by slope 2. Since slope 2 is a known value, or actually slope 1 / slope 2 for a specific input voltage is known, the number of counts during slope 2 until it reaches zero volt gives the voltage with a high precision.

The errors from variations of the clock frequency and the time constant of the integrator are mostly eliminated by this type of configuration, this is why quite high precisions are obtained. This elimination of the error is the result of the ramp period controlled by the clock instead of letting the ramp to be free. Dual slope analog to digital converters mostly find applications in digital voltmeters, where speed is not important but precision is.

Voltage to frequency type ADC's work by use of a voltage to frequency converter (VFC), by measuring the frequency of the VFC. By appropriate choice of voltage versus frequency curve, direct readout of the applied voltage can be obtained. For example, by counting the pulses for 10 msec. and using a VFC which generates 10 kHz/volt, 2 volts cause 200 pulses to be counted, which is 100 times the input voltage. i.e. two decimal point movements is required.

The major disadvantage of this type of ADC's are the speed (because of the quite large counting period requirement), the influence of the signals coming from the mains supply and the unavoidable effects of the transients at the input. In addition to these error sources, the complexity of a wide range linear VFC makes this type of ADC's useless for many systems.

Successive approximation type ADC's are the most common types for fast conversion requirements because of its low price / speed ratio. It consists of a bit selector, a bit memory array, a DAC and a comparator to decide the state of the bit.

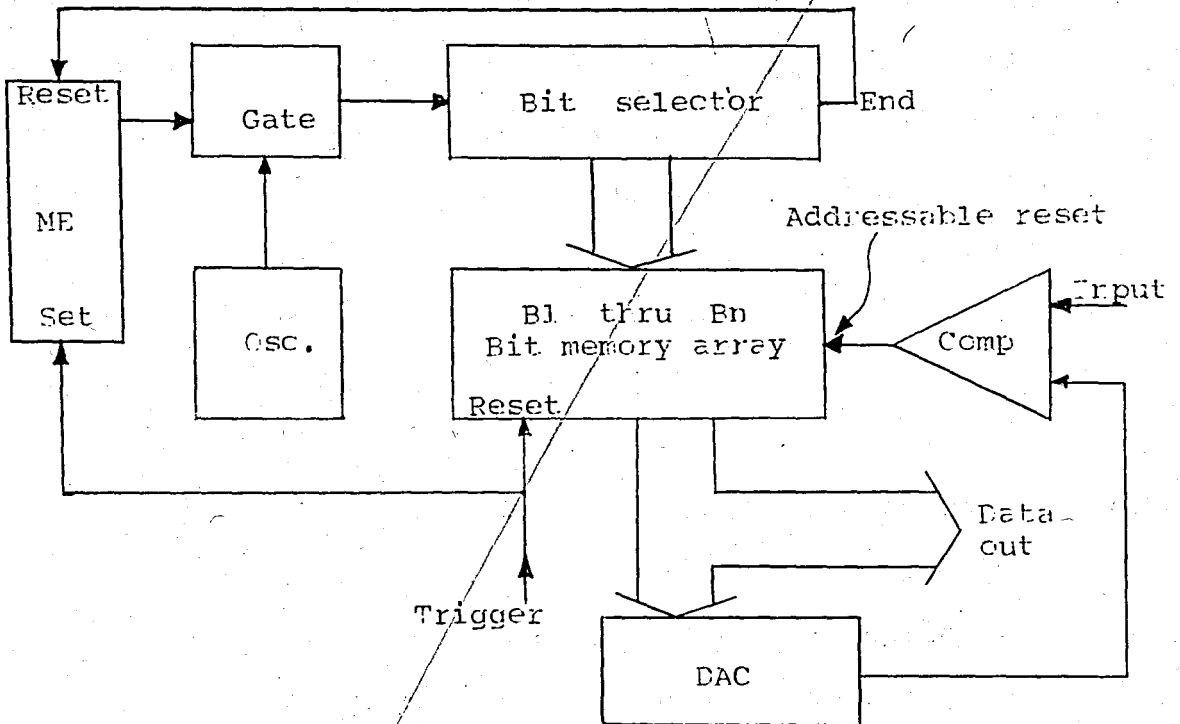

Figure 5: Block diagram of successive approximation ADC

When a trigger pulse is applied, ME is set to open the gate and all the bits in bit memory array are cleared. The clock pulses passing through the gate causes bit selector to sweep the bits beginning from the most significant bit (MSB). Corresponding value of MSB is half of the full scale voltage, which is con-

verted to analog by DAC. The comparator decides about the state of this bit, if it is larger than the input voltage it resets the bit, if not, lets it set. Then second MSB is tried which corresponds to one quarter of the full scale voltage. This voltage is added to the previously decided MSB value by the DAC, i.e. if MSB is "1", output of the DAC will be  $3/4$ , if MSB is "0", output will be  $1/4$  of the full scale voltage. The comparator again decides on resetting or letting at "1". Continuing, this way, after n comparisons, result becomes ready. After the LSB is set, bit selector sends an END message to reset ME and the system stops operation. For the next sample a new trigger pulse must be applied.

The operation of the bit selector and the addressed reset may be not as simple as it appears because of the practical problems arising while using the DAC. A step applied to the DAC results in some overshoot, which may give wrong information to the comparator and reset the wrong bit. To overcome this error source, addressed reset is gated by the clock to wait half a clock period before deciding to reset the bit or not. During this time, DAC output must settle to the desired value. It is possible to wait more than half a clock period. This of course reduces the speed of the system. A typical DAC and comparator output waveforms of a 6 bit and half clock period waiting ADC is shown in figure 6.

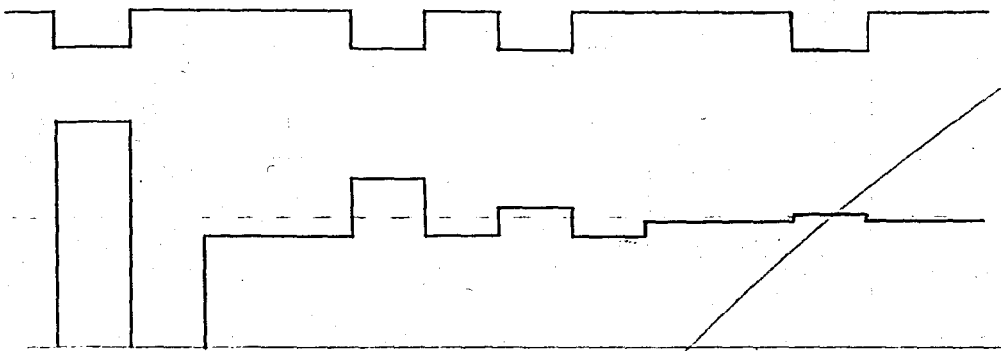

Figure 6: Comparator and DAC waveforms of a 6 bit successive approximation ADC

Comparing the successive approximation ADC's with the single slope or dual slope ADC's, a great advantage of speed can easily be seen. A single slope ADC performs its operation in  $2^n$  clock pulses while the successive approximation ADC needs only  $n$  clock pulses to complete the same job. The power of this system can be shown by a typical numerical example, for a 12 bit ADC, successive approximation is  $2^{12}/12 \approx 300$  times faster than a single slope one. But of course it costs more since too many logic circuits must be used compared with the other systems.

Flash ADC is the fastest type, for which no clock is required for conversion. It consists of  $2^n$  voltage comparators and reference voltages and a combinational logic to decode the output of comparators to binary. Figure 7 shows the block diagram of a basic flash ADC.

The voltage on each resistor is  $V_r/2^n$ , which corresponds to one

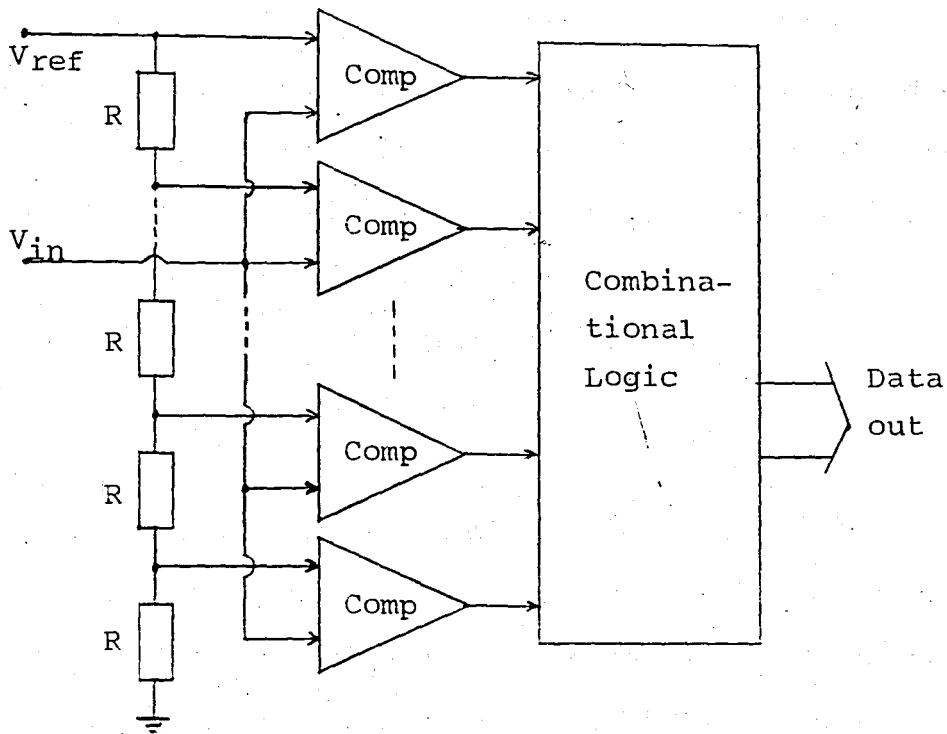

Figure 7: Block diagram of a flash ADC

LSB voltage. So, to each comparator, a different reference voltage is applied, each upper comparator having the reference voltage of the previous one plus one LSB voltage. For an analog input voltage of less than  $kV_r/2^n$  and greater than  $(k-1)V_r/2^n$ , the outputs of the comparators from 1 to  $k-1$  will be "1" and the remaining "0". By decoding it, binary output is obtained. The speed of the conversion is restricted by the speed of the comparators only. The propagation delay of the decoder will result with time domain shift, i.e. the value read at time  $t$  is actually the value of the voltage at time  $t-t_{pc}-t_{pd}$ , where  $t_{pc}$  is the propagation delay of the

comparator and  $t_{pd}$  is the propagation delay of the decoder. To give an idea about the speed of this system, if a 40 nsec. comparator is used with 100 nsec. delay time decoder, conversions per second will be 25 million while the propagation delay was 140 nsec. According to Nyquist theorem, up to 12.5 MHz frequencies can be sampled.

But this very high speed conversion capability of this type of ADC's have a great restriction in practice, which is exponentially increasing number of comparators required to increase the number of bits. For a 4 bit ADC, only 16 comparators were enough, but if 8 bit one is desired, 256 comparators are required, which effects the cost considerably. This property limits the use of the flash ADC's to very special applications.

To decrease the required number of comparators, two different flash ADC circuits are developed. One is called parallel ripple ADC, which consists of two  $m$  bit flash ADC's, one  $m$  bit DAC with  $2m$  bit resolution and an analog subtractor resulting with  $2m$  bit flash ADC. ADC1 selects the 'page' of the voltage. This value is again converted to analog and subtracted from the input voltage. Resulting voltage gives the least significant part of the input and is converted to digital by ADC2. This technique reduces the number of comparators considerably, but because of the analog devices used in the circuit, speed will

be lower.

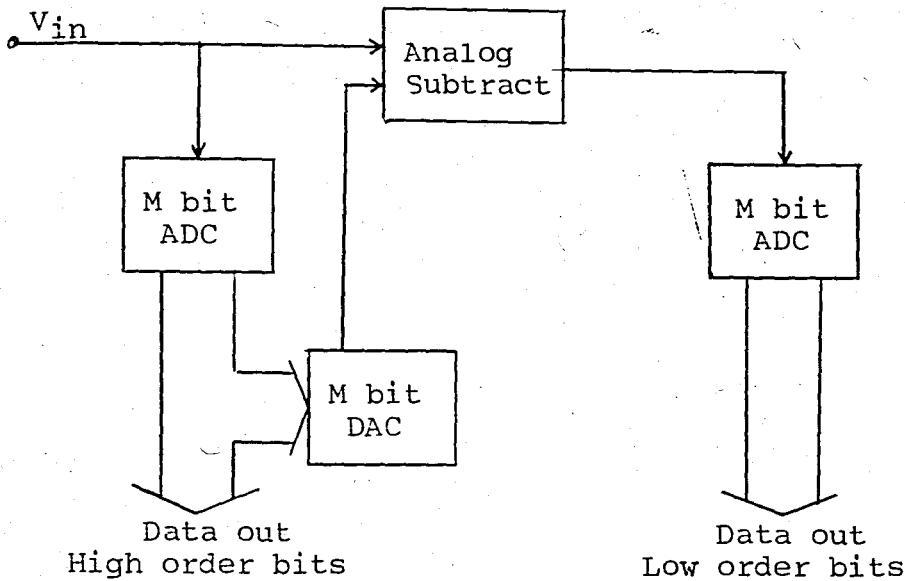

Figure 8: Parallel ripple ADC

Another type of flash ADC is called Variable Threshold Flash, for which only  $n$  comparators for an  $n$  bit ADC is used. It requires also  $n$  DAC's of from 1 bit to  $n$  bits. To obtain accuracy, these DAC's must have  $n$  bits resolution. As seen in figure 9, each comparator has its threshold voltage as a feedback from the upper comparators. Whenever an upper comparator turns to "1", all the threshold voltages of lower comparators increase and they turn to "0". When input voltage increases a little more, comparators begin to turn to "1" beginning from the LSB. Since the settling of the comparators and the DAC's take time and it appears to be settling sequentially,

the conversion time increases considerably.

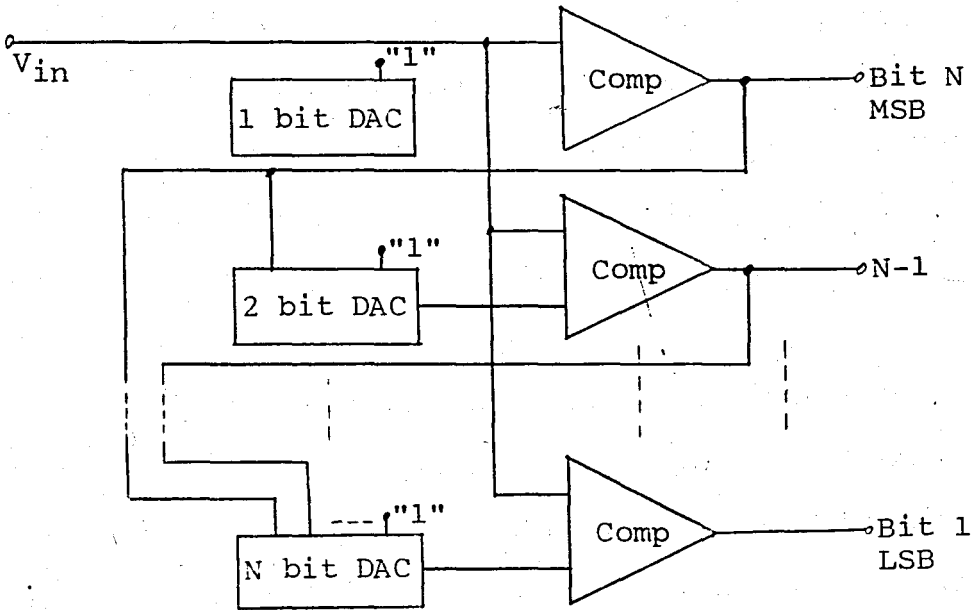

Figure 9: Variable threshold flash ADC

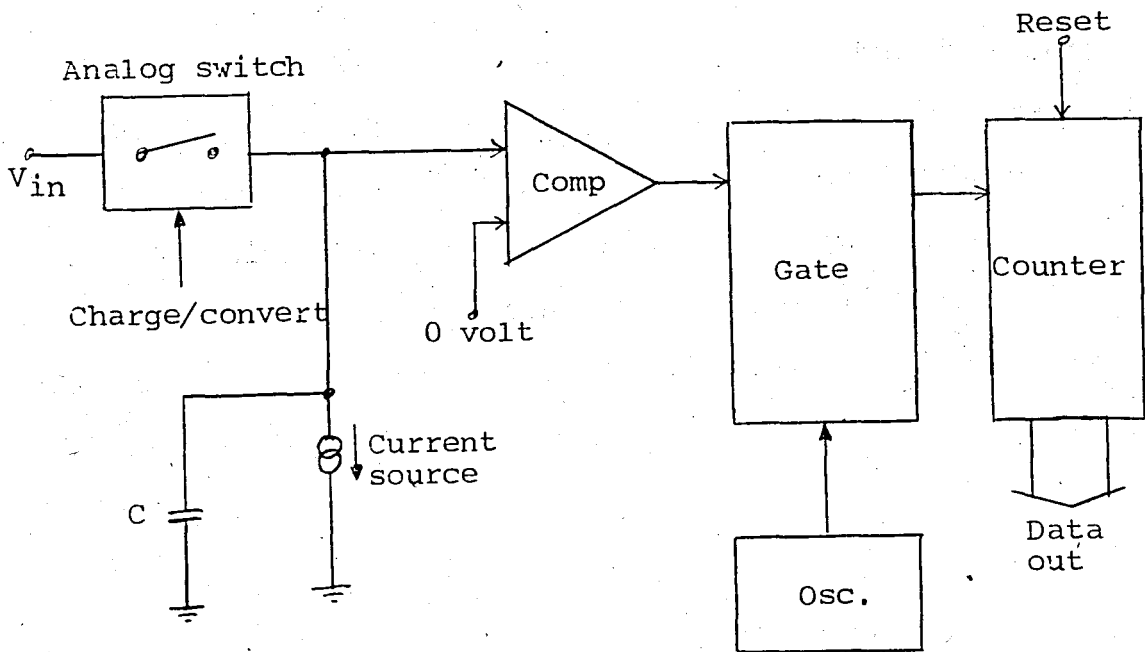

Figure 10: Wilkinson ADC

Wilkinson ADC (figure 10) is a very similar one to the single slope ADC. The only difference is that instead of the input voltage is being kept constant and a ramp beginning from zero volt is applied, a capacitor is charged to the input voltage and discharged with a constant current while counting the time for the capacitor voltage to cross zero volt.

This system has a special use in pulse techniques since its accuracy is not good but it has very high resolution and very low differential non-linearity. The basic use of Wilkinson ADC's are in the multichannel analyzers, where, before a measurement, always a calibration procedure has to be performed, (so accuracy is not important).

A developed version of the Wilkinson ADC is the dual ramp ADC. (figure 11). It has several times higher conversion speed with the same clock frequency. The principle is to discharge the capacitor with, for example, 64 times the required current for Wilkinson type, while counting 64 each time instead of 1, with the first clock pulse after zero crossing, to apply a reverse normal current and count down by one until next zero crossing occurs.

After convert signal comes, the decision unit switches S to  $I_1$  by which the capacitor discharges rapidly, and connects the

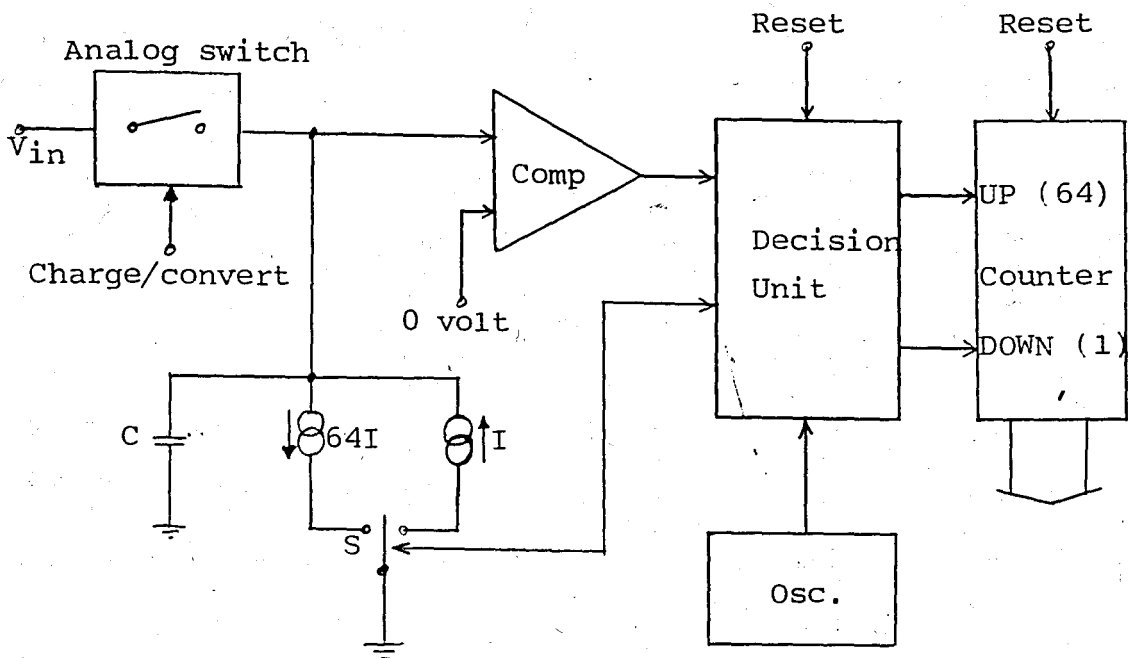

Figure 11: Dual ramp ADC

oscillator output to the count up input of the counter. Each clock pulse increments the counter by 64. After zero crossing, the decision unit switches S to  $I_2$  and connects the clock to count down by one at each clock. So the excess number of counts are taken back. Since two different slopes are used, the ratio of these two must be very precisely adjusted. Also the switching times must be very short comparing with the clock period to avoid false counting, because the delay of only  $1/64$  of the clock period will result with 1 LSB higher result than the expected number.

It is convenient to tabulate the basic properties of these

ADC's to have a complete idea:

<u>TYPE</u>	<u>SPEED</u>	<u>PRICE</u>	<u>ACCURACY</u>	<u>LINEARITY</u>	<u>PRECISION</u>
Sing.sl.	low	low	medium	high	very high
Dual sl.	low	low	high	high	very high
VFC	very low	high	high	high	very high
Succ.ap.	high	medium	high	medium	low
Flash	very high	very high	high	medium	medium
Wilkinson	low	low	low	high	very high
Dual ramp	medium	medium	low	medium	high

## GENERAL DESCRIPTION OF THE BUS AND THE BUS COMPATIBLE ADC

The bus compatibility of the ADC, or in general the data acquisition system (DAS) is achieved by using open collector outputs which are wired-OR to the other units by the bus. The parallel outputs and inputs are designed as negative logic because of the restriction of the wired-OR connection, only the serial output is kept positive logic. The digital bus contains 13 data lines one being the serial output, 3 channel number lines (Since there are 8 analog channels), 2 service unit address lines, one line to inform that the bus is busy, one line to inform that the service unit is working and one line to indicate which unit is specifying the channel number, total of 21 lines. Analog section contains 8 lines. The shortened names of these lines are listed below:

D1...D12 :From LSB to MSB data lines (negative logic)  
SO :Serial output (positive logic)  
A1,A2 :Service unit address lines (negative logic)  
C1,C2,C3 :Channel number lines (negative logic)  
FA :Forced address line (negative logic)  
BSY :Bus busy line (negative logic)  
WRK :Service unit is working (negative logic)  
AD0...AD7:Analog data lines ( $0 < V_i < 2.048 \text{ V}$ )

The operation of the bus is very similar to that of a telephone system. When a consumer device needs service, it looks at BSY line. If BSY is low, it has to wait, because it means that another consumer is using the bus. When it sees BSY high, i.e. bus is free, it pulls it low informing that bus will be used. Then it applies the analog voltage to one of the analog data lines (AD0 thru AD7) if this voltage has to be identified by itself (If the analog data lines are already connected to the points to be measured, there is no such step), sets the corresponding (or desired) channel number on C1, C2 and C3 while pulling down FA line (which means "you have to process the voltage on the line I specified") and finally it specifies from which service unit it wants the data by use of the lines A1 and A2. When one of the service units sees that it is addressed, it pulls WRK line low indicating that it understood that it is addressed and is working. When data becomes ready, it pulls WRK high again, which means that the data is ready on the bus. After the consumer device takes the data, it pulls BSY line high, leaving the bus free.

If FA is not pulled down, the analog channel lines must be kept high. In this condition, the counter in the service unit counts one and processes the next channel voltage and as the output it gives the channel number besides the data.

A service unit cannot have the address 00 ,i.e. A1 and A2 both high because the service unit is triggered by its address and 00 is the idle position of the bus.

The serial output has a variable BAUD rate,prestable by the jumpers on the DAS digital input-output and successive approximation register (SAR) logic board,1801.When data becomes ready,the DAS pulls SO line low for one bit long as the start bit,then gives the data starting from the MSB,adds the three bit channel address at the end,then pulls SO high.

The internal counter for channel addressing is put to decrease the required number of lines for long distance communication. This way a consumer has to specify only the service unit address by two lines,and take the data from the serial output line.If channel number is not the desired one,it can request a new data by keeping BSY low ( that way it does not lose control of the bus).It can go on until the consumer receives the data of the desired channel.So only 4 lines are used for this purpose:BSY,A1,A2,SO.

## PRINCIPLE OF OPERATION

When the system is addressed, Address Sense Block sends a message to the State Information. If BSY is low, State Information Block sends a message to output by pulling WRK low, increments the channel number by applying a pulse to Channel Incrementer and also applies a pulse to the Bit Selector of the SAR which clears all the bits of the Bit Memory Array. The Channel Select looks at FA, if it is low, takes C lines as inputs, if high, puts the data of the Channel Incrementer on C lines. Analog Data Selector selects one of the analog channels according to the data given by Channel Incrementer. This analog data is buffered, sampled and hold, and applied to one of the inputs of the comparator. The bit selector, then, starts to sweep the bits to be tested. Each time the DAC gives an analog equivalent of the new combination of the bits and applies it to the comparator. The bit selector also specifies the bit that has to be resetted if necessary and this information is given to the Addressed Reset Block. After the test of all the bits are completed, the bit selector informs that the job is completed, and by this information the parallel to serial converter is loaded while the state information was pulling WRK high. The parallel data passes

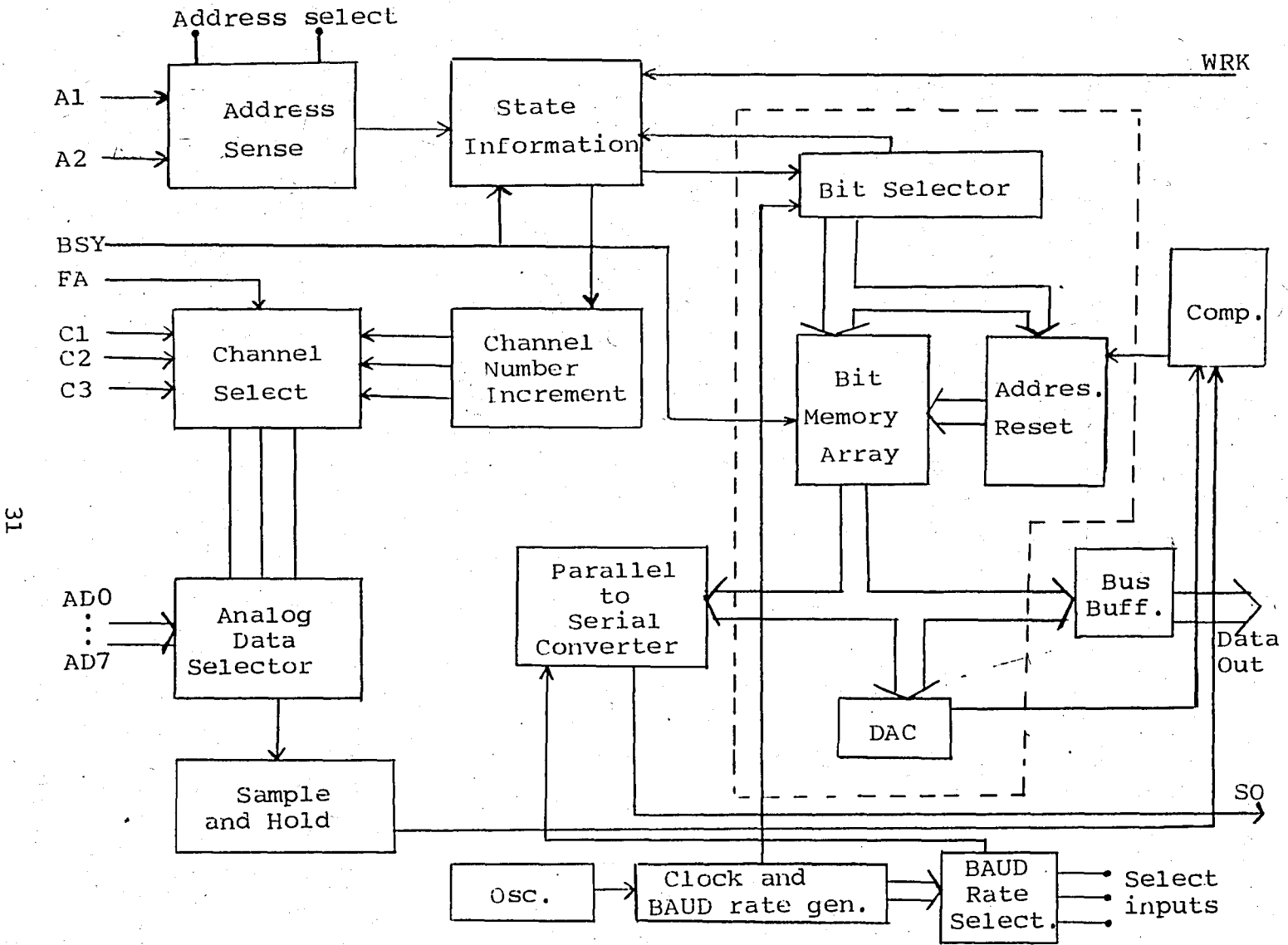

31

Figure 12:Block diagram of the Data Acquisition System

through the bus buffer, which is a set of open collector invertors. The parallel to serial converter sends the data on the SO line with the BAUD rate specified by the Baud Rate Generator and the Baud Rate Selector. To convert a new sample, the address must be removed and applied again.

The Address Sense circuit consists of two inverters and an AND gate. The address inputs are negative logic (i.e. 0 volt means "1" state).

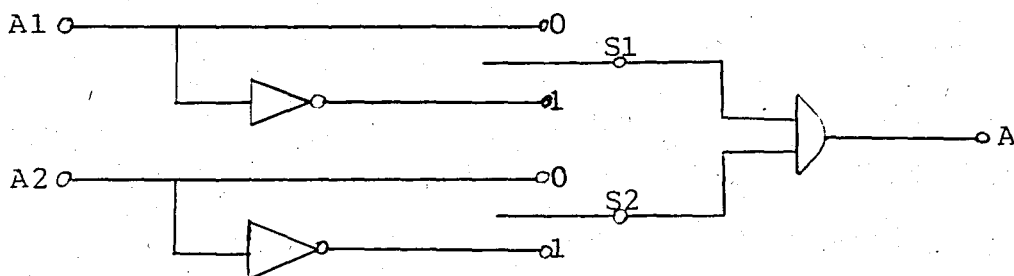

Figure 13: Address Sense circuit

By use of S<sub>1</sub> and S<sub>2</sub>, address can be changed. 00 cannot be used as an address since it is the idle position of the bus.

The State Information logic has a 4 μsec monostable and three flip-flops for the sequential informations. The flip-flops are used as D flip-flops with D="1". When the DAS is addressed, mono is triggered and the FF2 is triggered by Q̄ of the mono.





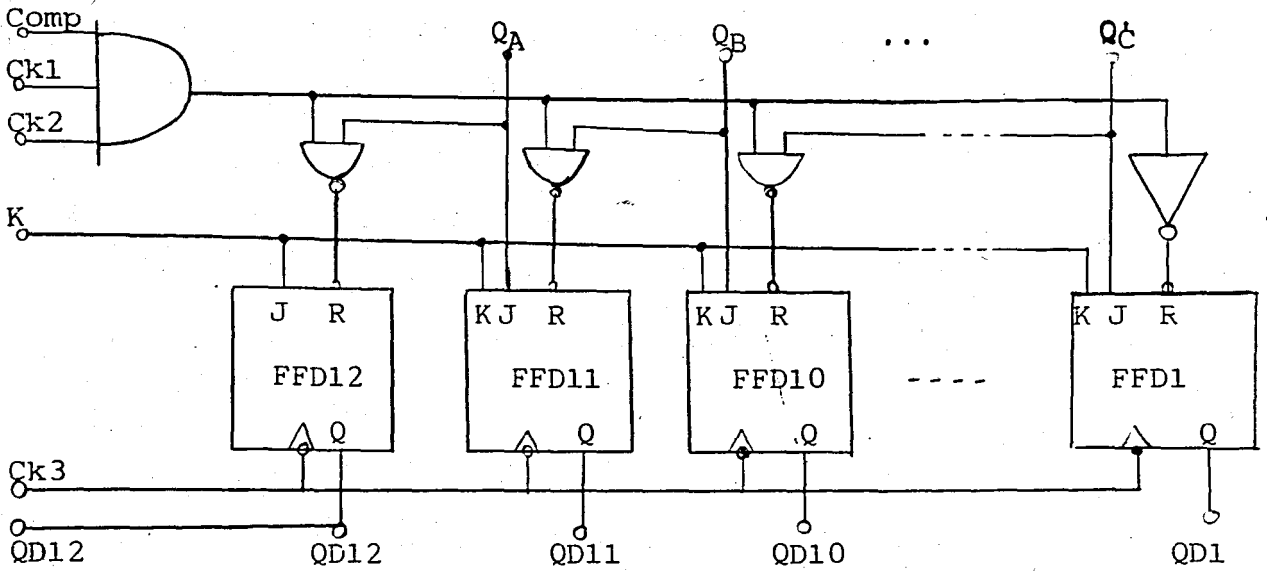

Figure 16: Addressed Reset and Bit Memory Array.

for the remaining bits. The reset input of the last flip-flop does not require gating because it is the last bit to be decided and no other reset information will be applied to the bit memory array from then on.

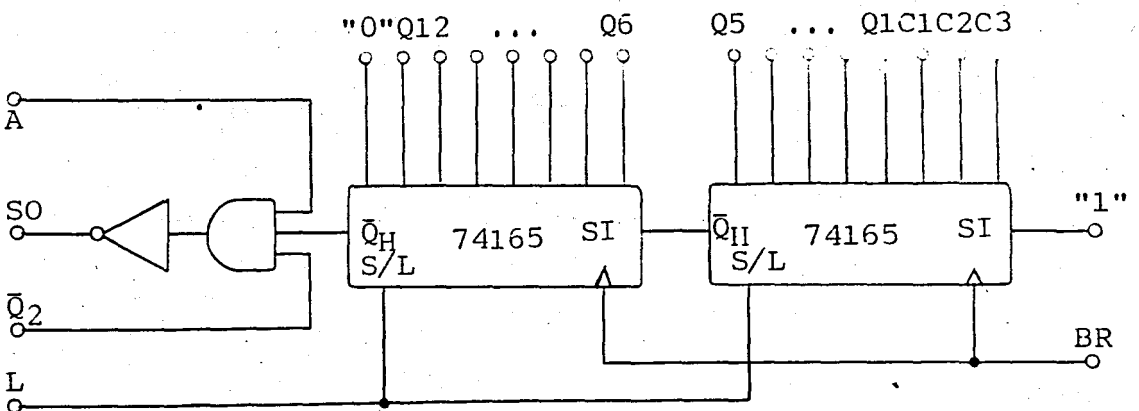

Figure 17: Parallel to Serial Converter circuit

Parallel to Serial Converter is a 16 bit parallel in serial out shift register obtained by cascading two 8 bit ones. One start bit, 12 data bits and 3 channel address bits are sent by this shift register, a total of 16 bits. When the conversion is end (i.e.  $\bar{Q}_2$  is "1" ), at the first clock pulse while L was low loads the shift register with a "1" appearing at  $\bar{Q}_H$ . This results with one start bit of "0" appearing at  $S_0$ . Then, according to the BAUD rate selected and applied to BR, 12 bits are sent (starting from the MSB), adding the three channel number bits starting from the LSB. If the address is removed before the end of the serial output, sending of the data is stopped. At the end of the message, the "1" at the serial input of the shift register fills all the bits and  $S_0$  remains at "1".

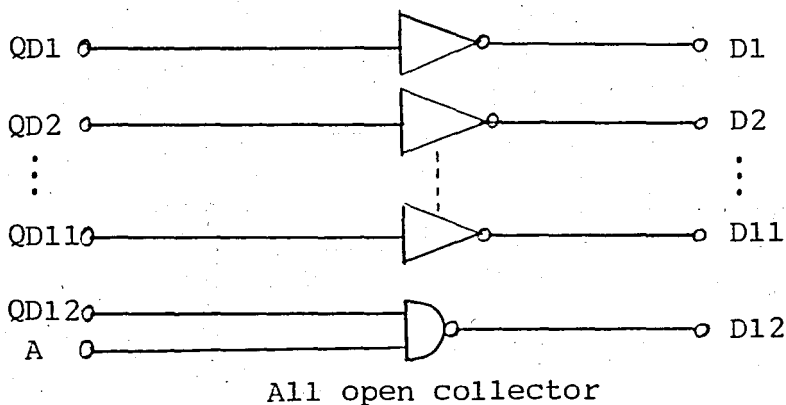

Figure 18: Bus Buffer

The Bus Buffer is made up of 11 open collector invertors and an open collector NAND gate. The Q's of the bit memory array flip-flops from 1 to 11 are directly connected to the invertors. The 12'th bit is NAND gated by the address information ,A, because when the DAS is not addressed, QD12 stays at "1" and if it is directly applied to the buffer-invertor, it will pull the D12 line low as a wrong information.

The channel incremter is a three bit counter made up of one 7490. The channel select block consists of a quad 2 to 1 line multiplexer, 74157, in which three of the multiplexers are used, a quad latch, 7475, and open collector NAND gates.

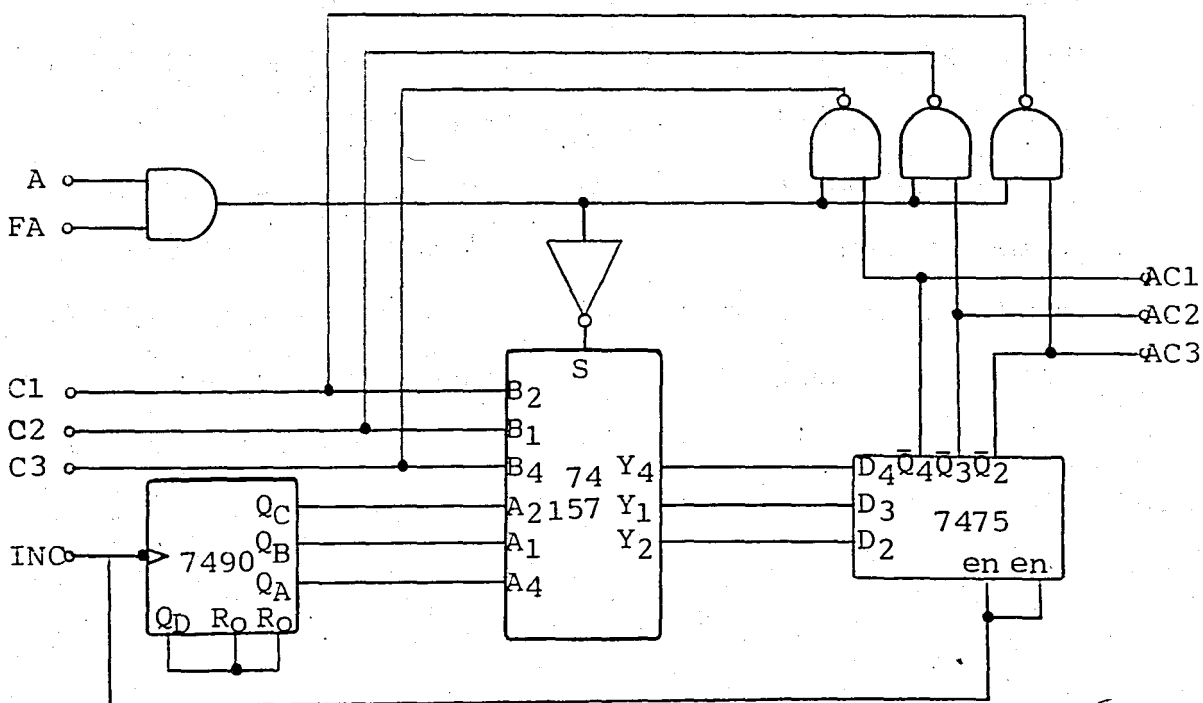

Figure 19: Channel incremter and channel selector circuit

When the DAS is addressed, INC becomes "1" for 4 usecs and the outputs of the multiplexer are latched in 7475. This data is selected according to the state of FA. If it is "0" (i.e. it is high), the channel number selected by the 7490 counter is accepted as the channel number and the open collector NAND gates are opened to force this number on the C lines. If FA is "1", the NAND gates are closed letting the C lines as the inputs to be selected. The outputs of 7475 are then sent to the analog multiplexer by AC lines. At the end of the INC pulse, latch is disabled and the counter counts one to be prepared for next data request.

Analog data selector is a single chip CMOS 8 to 1 analog multiplexer (14051). Buffer and the sample and hold circuitry is accomplished by use of a double FET input op-amp (TL082). High slew rate of 12 volts/usec. of these op-amps were satisfactory in application of this sample and hold circuit. Inputs of the multiplexer are protected by connecting 1.1 kohm resistors in series. Output of the multiplexer, which is connected to the first op-amp is biased by inserting a 90 Mohms resistor between this point and ground. The multiplexer select inputs are connected to AC1 thru AC3, the outputs of the latch. As the analog switch of the sample and hold circuit, a CMOS one with low ON resistance (14066) is used. Output of the S/H is connected to the comparator.

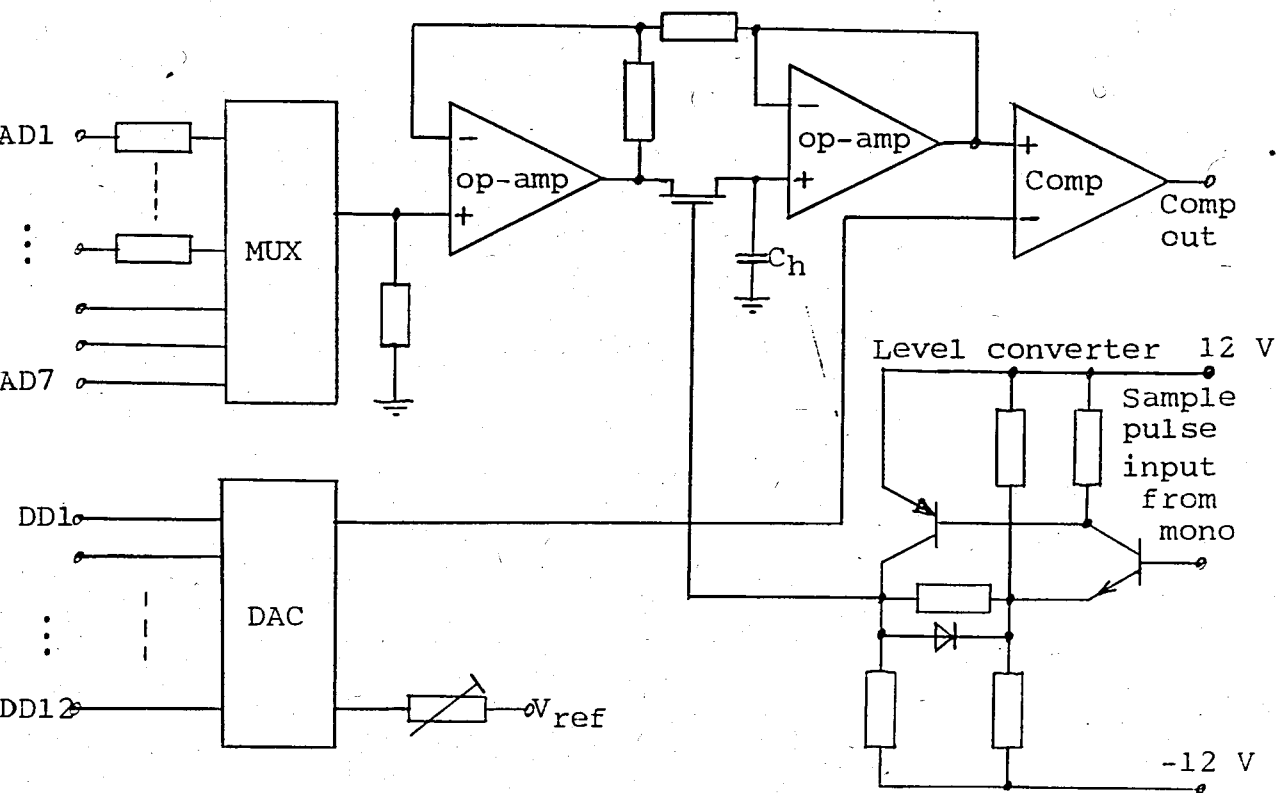

Figure 20: Analog section circuitry

The comparator used is a very sensitive and fast one, LM361, with gain of 5000 and propagation delay of less than 15 nsec. This much sensitivity was required because the input voltage and the DAC voltage are restricted at 2.048 volts maximum. For 12 bits, it makes .5 mvolts per LSB. The 4  $\mu$ sec. pulse coming from the first monostable is fed to a level converter to obtain the required ON and OFF voltage levels of the analog switch. The analog multiplexer and the analog switch are fed with plus-minus 5 volts which are obtained from the 12 volts by use of zener diodes.



High speed switching is accomplished by use of emitter coupled logic configuration . The  $Q_s$  and  $Q_n$  in the DAC circuit diagram makes a current switch. The bases of all  $Q_n$ 's are connected together to a constant voltage of approximately 2.5 volts. This voltage is assumed to be the reference voltage of these switches, such that if the voltage at the base of  $Q_s$  is lower than this voltage,  $Q_s$  will conduct and sink all the current that the current source is sourcing. If it is higher, then the current will flow into the ladder network.

To obtain a current source with low temperature drift, the transistors are connected in such a way that the voltage drift of one of the transistor's base-emitter junction is ~~been~~ compensated by the other's.  $Q_2$  is used as a current source to shift the reference voltage to with respect to  $V_{cc}$ . This current is determined by the voltage on  $R_4$ , so at first it is required to keep this voltage stable. This is accomplished by inserting one more base-emitter junction,  $Q_1$ . This way the voltage at the base of  $Q_1$  is transferred to  $R_4$  with high stability. It resulted with a stable voltage on  $R_5$ , too. The  $Q_c$ 's are the current sources, again requiring stable voltages on the  $2R$  resistors at their emittors. Now,  $Q_3$  is put to improve two effects, one is it is used as a buffer to reduce the current sinked from  $R_5$ , other , the base-emitter junction is compensating the unstability of the base-emitter voltages

of Qc's.

As the reference voltage, a high stability one is used. The only problem left was the precise resistors. This is solved by selecting the identical ones among many high quality metal film resistors. As a result, all resistors are selected within 0.05% tolerance.

## CONCLUSION

The desired specifications could not be obtained completely because of the practical problems that arose in the analog section of the system. The conversion time that was desired to be achieved was as low as 2.5  $\mu$ secs, but this was thought without a sample and hold circuitry. The insertion of the sample and hold circuit increased the time by 4  $\mu$ secs.

To obtain bipolar operation characteristics, it was thought to design a DAC with bipolar output and compare it directly with the input voltage. This type of operation is tried to be realised by feeding the DAC with two split supplies, but it resulted with sustained oscillation. So the design is changed to a single supply DAC and the input voltage is shifted up and applied to the comparator.

Even in this condition, there still were some overshoot and dumping oscillation at the output of the DAC. To optimize the readout accuracy, system speed had to be reduced and this way an accuracy of 9 bits is reached. Remaining 3 bits are left in in the oscillating region. By use of a computer, if higher

resolution is desired, it is possible to take more samples and calculate the statistical average, which is almost equivalent to decreasing the system speed.

The successive approximation register part, i.e. the digital part of the system is working successfully. It is seen that all of the problems arose in the analog part. As a further study, it is possible to design a better analog part for this system to achieve true 12 bit accuracy. In this case only the upper printed circuit board has to be changed.

This system is thought to be operated in conjunction with a computer. But the bus system itself has a drawback for such an operation without a hardware between the computer and the bus. Since there is no controller on the bus, it is required to "catch" the bus immediately after BSY is seen high. For a computer, it is the easy way to look at this line, then, if it is high, send BSY according to the program flow. But the time which passes between seeing it high and sending the message, which is in the order of  $\mu$ secs for a computer, may cause problems in such a way that during this time it is possible for another consumer to begin to work on the bus. To overcome this, a simple hardware has to be connected between the computer and the BSY line.

The system, now, is in such a situation that it can be used in many applications, and it is open to further developments.

97

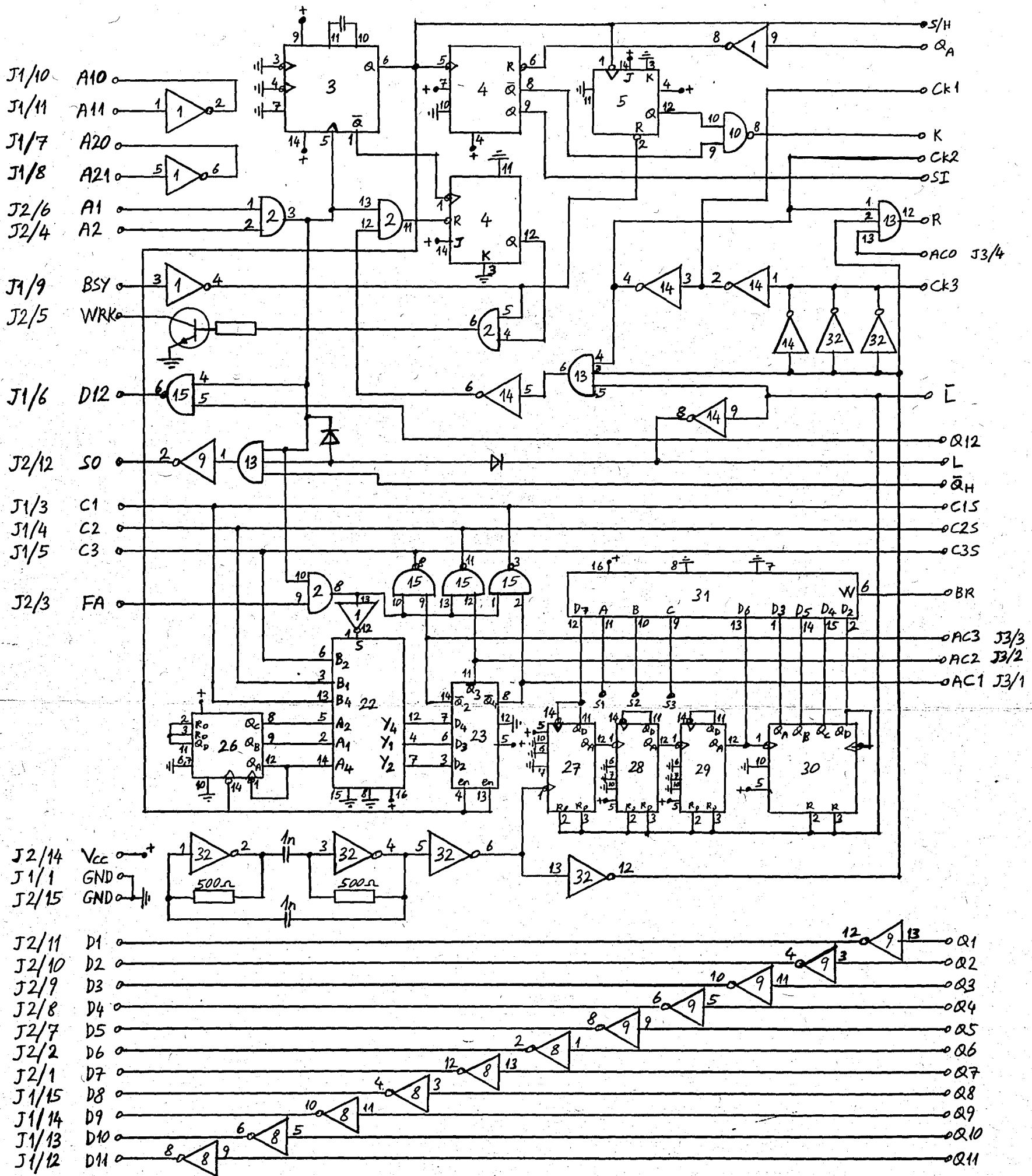

DIGITAL PART (A)

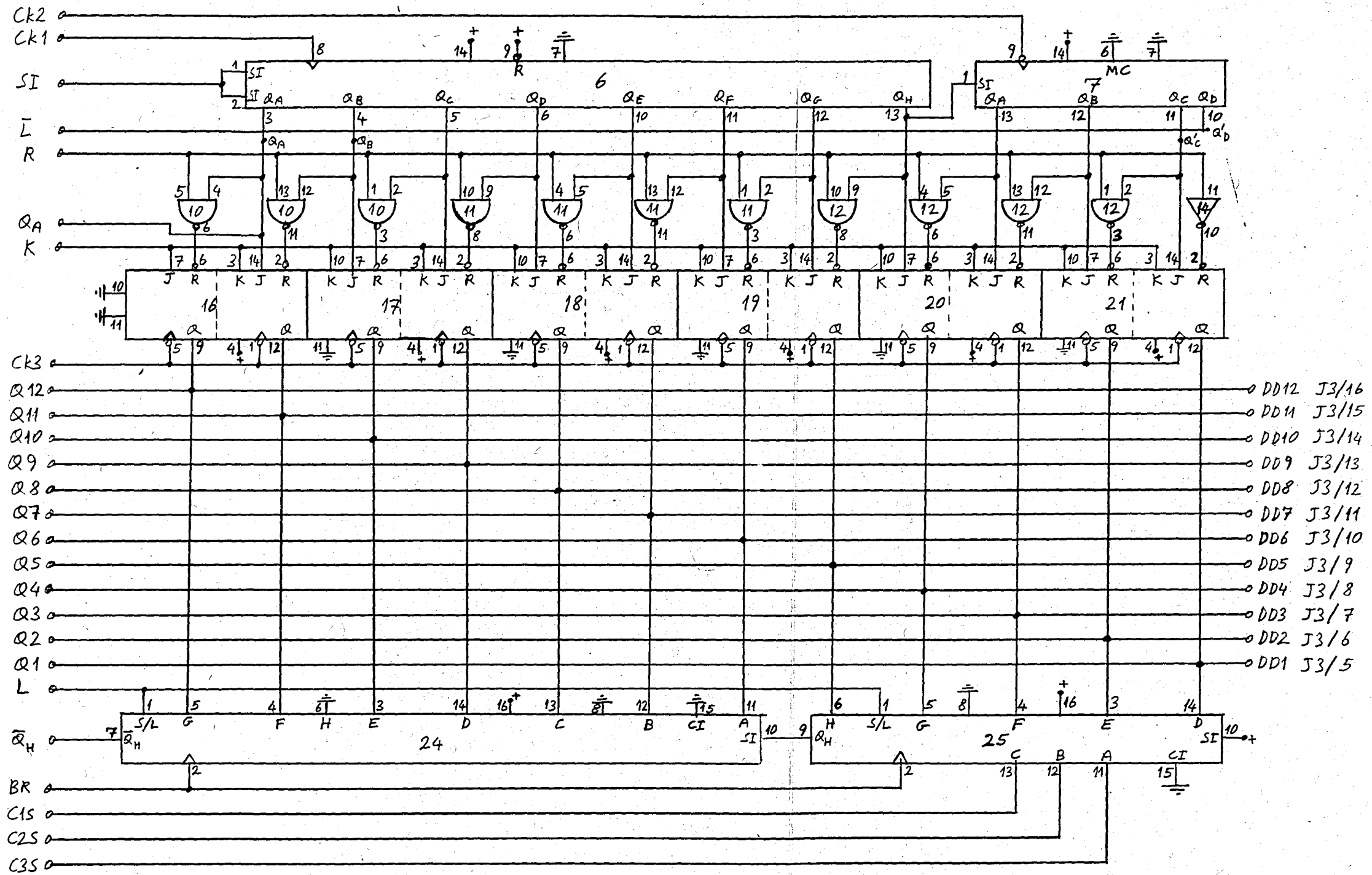

DIGITAL PART (B)

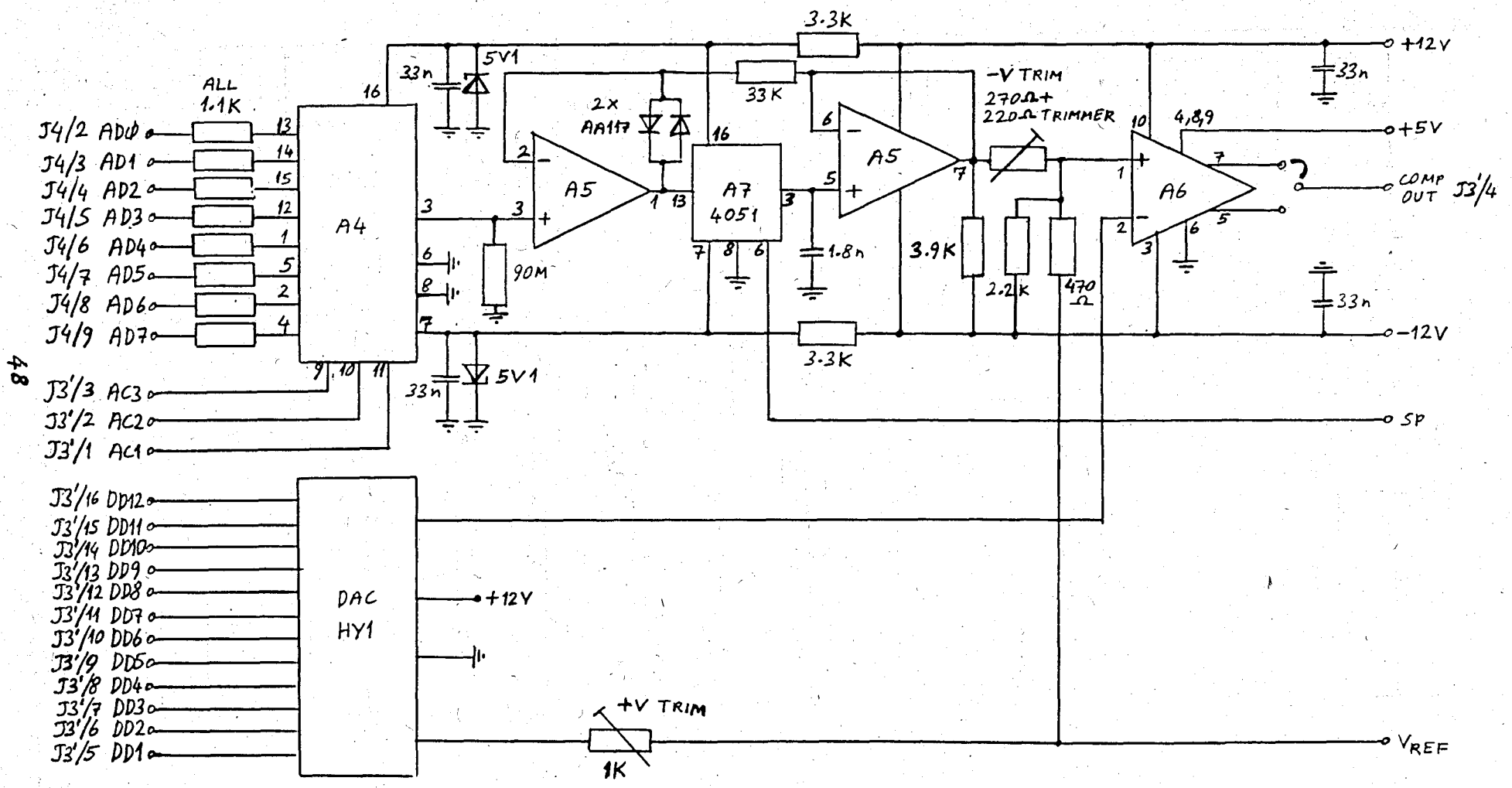

ANALOG MUX AND S/H

67

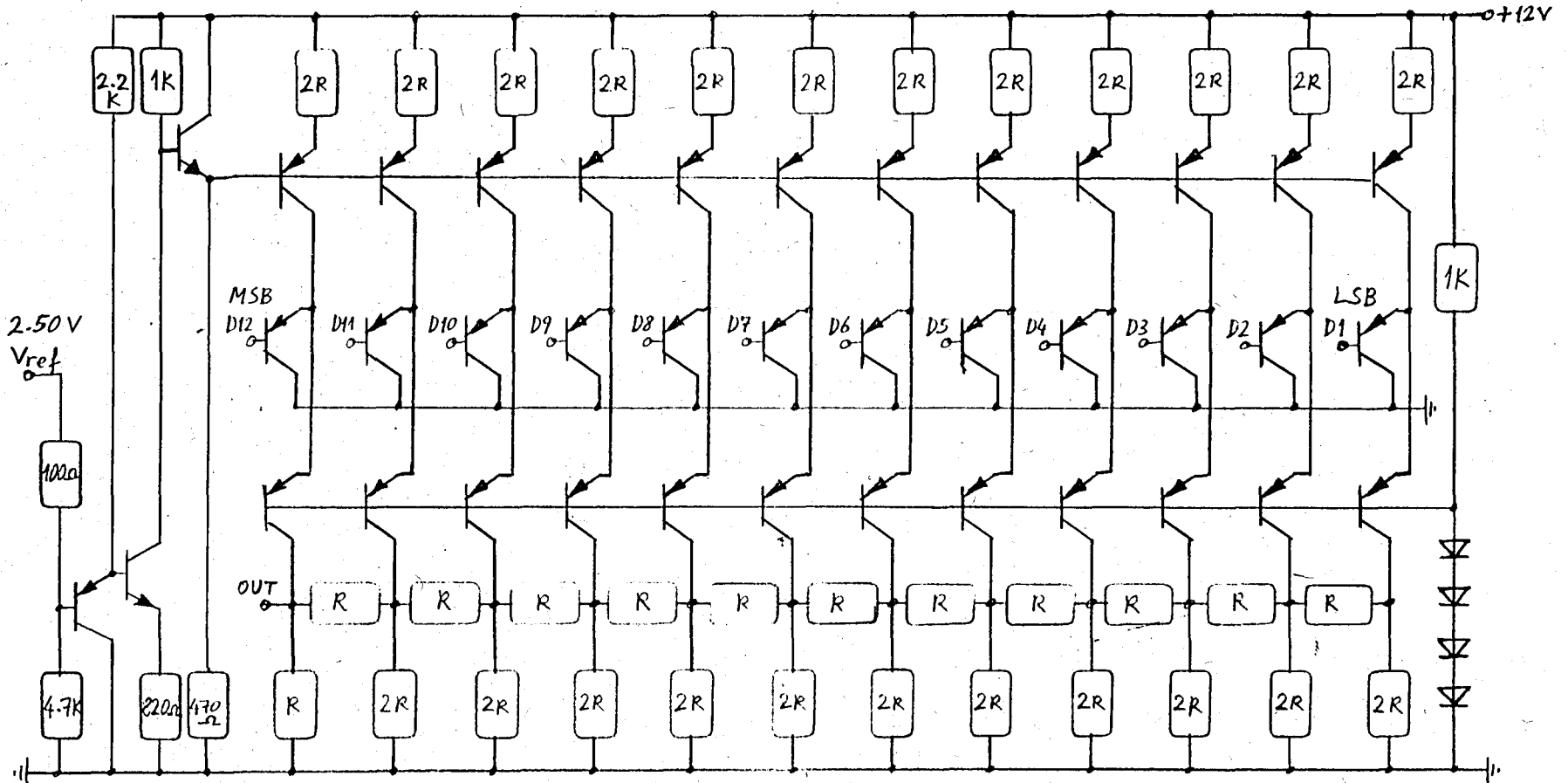

ALL NPN TRANSISTORS ARE BC237, PNP ARE BC308

R = 150Ω 0.5% METAL FILM

DAC

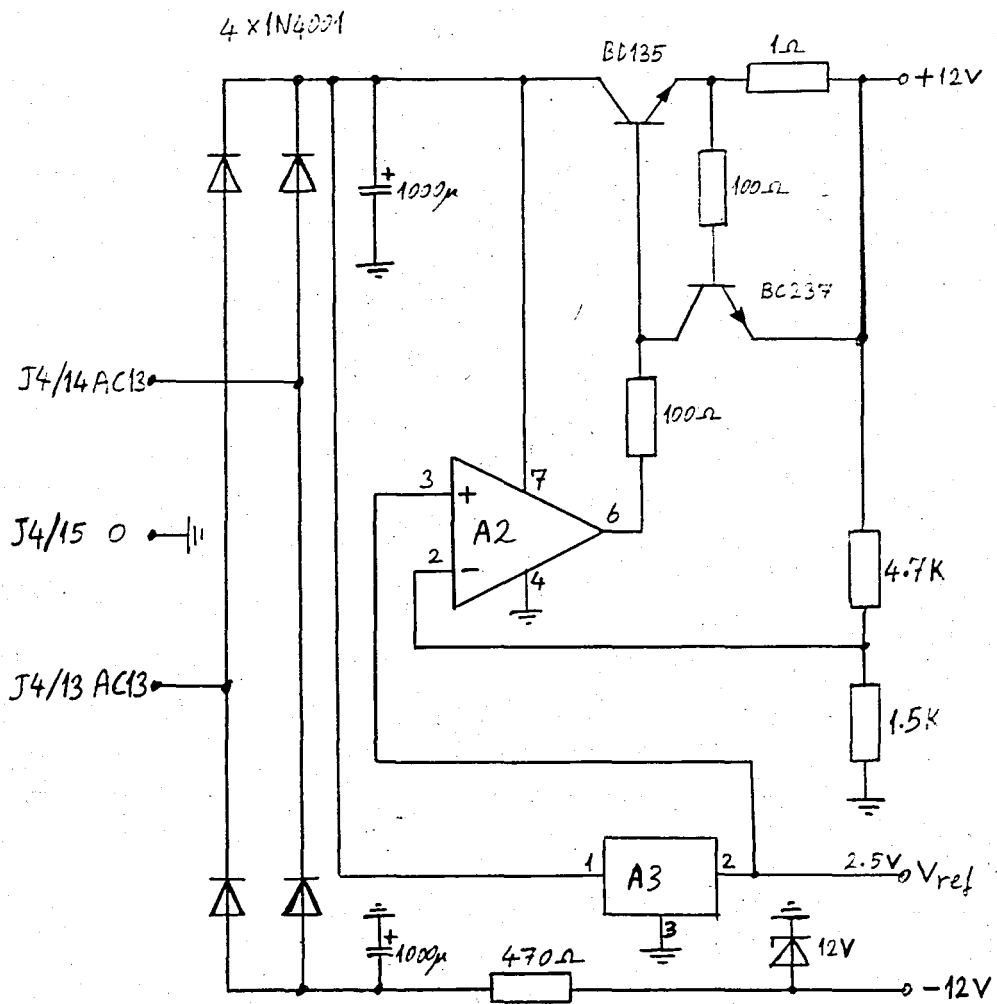
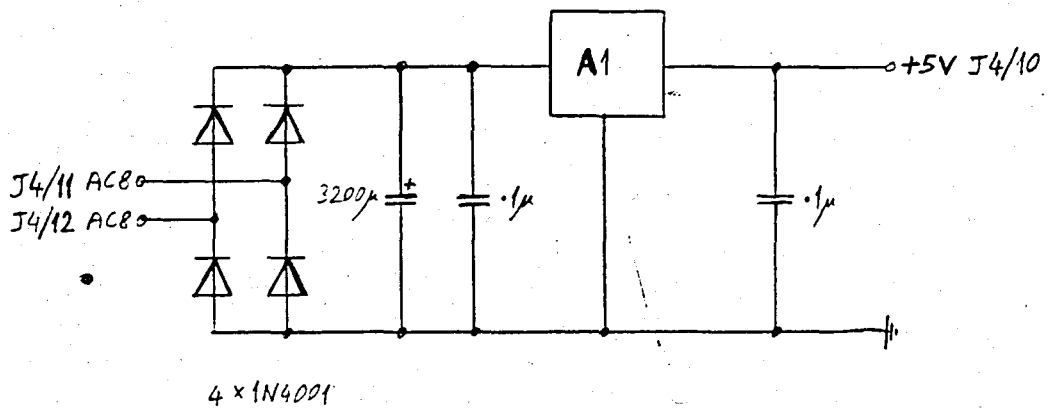

POWER SUPPLY

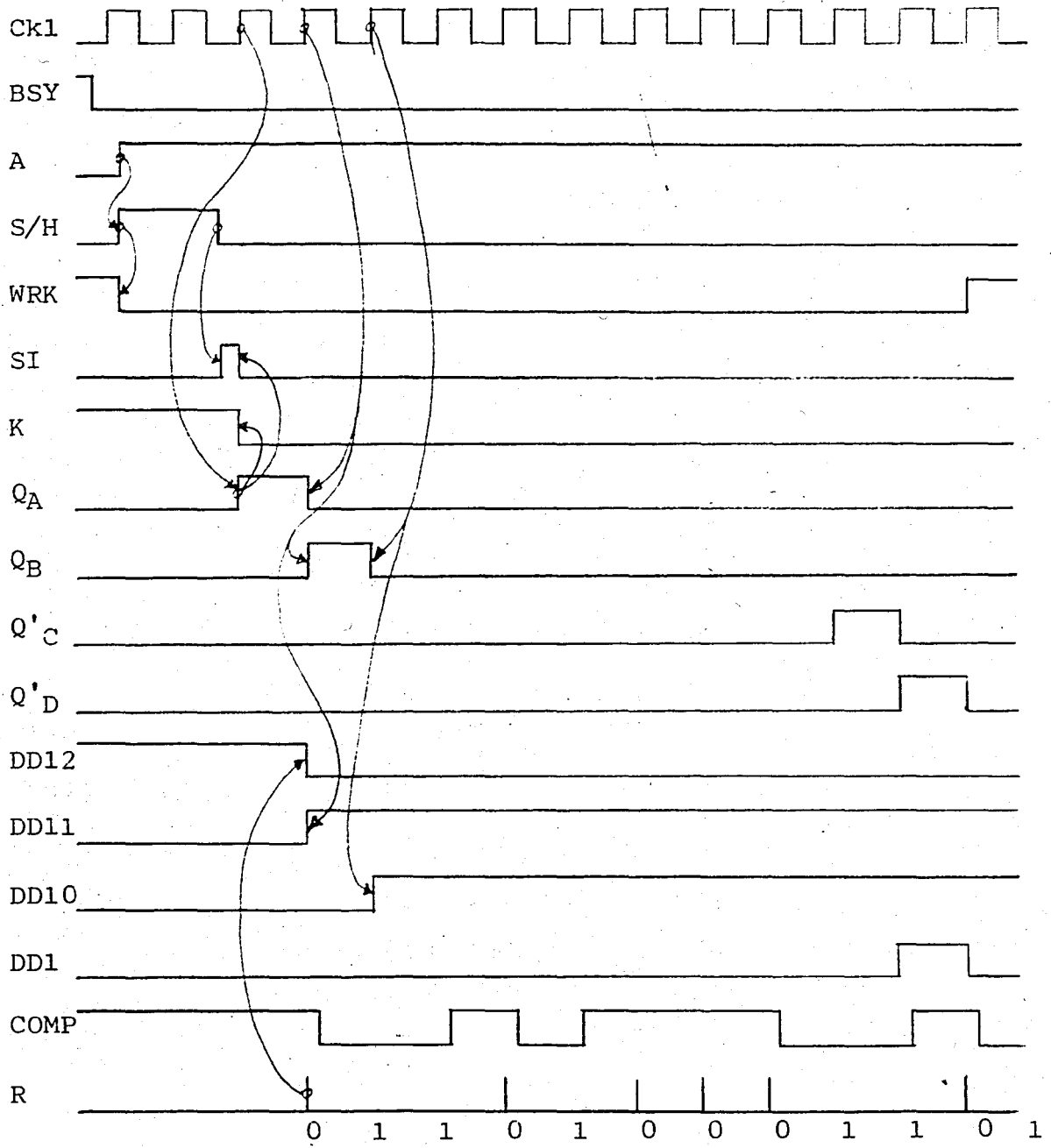

WAVEFORMS OF ADC



COMPONENTS LIST

Digital Part (Integrated Circuits)

1	7404	17	7473
2	7408	18	7473
3	74121	19	7473
4	7473	20	7473
5	7473	21	7473
6	74164	22	74157
7	7495	23	7475
8	7406	24	74165
9	7406	25	74165
10	7400	26	7490
11	7400	27	7490
12	7400	28	7490
13	7411	29	7490
14	7404	30	7493
15	7403	31	74151
16	7473	32	7404

Analog Part (Integrated Circuits)

- 1 7805
- 2 741
- 3 MC 1403
- 4 MC 14051
- 5 TL 082
- 6 LM 361
- 7 MC 14066

## APPEDDIX A

### Interfacing with a microprocessor

For demonstration, the system is interfaced to a microcomputer based on 8085. Interfacing is done via a triple port, 8255 of Intel. The C and B ports are assigned to be inputs and A port to be output. The first 7 lines of port A are used as outputs from the computer. These are assigned in such order:

A0,A1,A2	:Channel address
A3	:FA line
A4,A5	:Device address
A6	:BSY line
A7	:Not used

The B port is connected to first 8 of the data lines. i.e. to the lowest 8 bits. Low half of the C port is connected to the remaining 4 bits. WRK line is connected to C7. C4, C5 and C6 are not used.

The inputs to the computer are connected directly to the bus. The outputs of the computer, A0 thru A6, are connected to the bases of 7 transistors and the collectors of these

transistors are connected to the bus since the bus configuration is open collector.

As the input-output of the computer, a teletype is used. The program is such prepared that entering the desired channel number is enough to operate the system. Computer asks for the voltage of that channel, converts it to BCD and writes the channel number and the voltage. The source code of the program is given in Appendix B.

## APPENDIX B

Sample program for 8085 to use the DAS

In this program, it is assumed that the port is previously programmed and the monitor program has the input-output subroutines available for the user program.

```
START  MVI A,CR      SEND CARRIAGE RETURN
        CALL OUTCHR
        MVI A,LF      SEND LINE FEED
        CALL OUTCHR
        CALL INCHR    GET CHANNEL NUMBER
        SUI 30H
        CPI 8         BETWEEN 0 AND 7?
        JNC START    IF NO DON'T ACCEPT ENTRY
        MOV B,A       IF SO START CONVERSION,SAVE NUMBER
        LDA 30H
        STA DECIM     STORE 0 TO THE PLACE AFTER
                     DECIMAL POINT
        LDA 2EH
        STA DP        STORE DECIMAL POINT
        MVI A,BSY
```

OUT PORTA	SET BSY LINE
ORI 80H	SET FA
ORA B	
OUT PORTA	SET CHANNEL NUMBER
ORI 30H	
OUT PORTA	SET DEVICE ADDRESS
LOPWRK IN PORTC	
ANI WRK	TEST FOR END OF WORK
JZ LOPWRK	IF NOT END YET
IN PORTC	TAKE HIGHEST 4 BITS
CMA	COMPLEMENT TO OBTAIN IN POSITIVE LOGIC
ANI 15	DISCARD NON DESIRED BITS
RRC	TAKE HIGHEST 3 BITS
MOV H,A	
IN PORTB	TAKE LOW 8 BITS
CMA	
RRC	LSB TO CARRY FLAG
MOV L,A	
JNC CONT1	IF LSB IS ZERO
LDA 35H	IF LSB IS '1',IT HAS A VALUE OF
STA DECIM	0.5 MILLIVOLTS
CONT1 LXI D,BCDSAV	ADDRESS OF THE CONVERTED BCD NUMBERS
	TO BE STORED
PUSH B	SAVE CHANNEL NUMBER
CALL BIDE	PERFORM BINARY TO BCD CONVERSION

```

POP B
MOV A,B
ADI 30H      ASCII EQUIVALENT OF THE CHANNEL NO
CALL OUTCHR  SEND CHANNEL NUMBER
MVI A,SP
CALL OUTCHR  SEND A SPACE
LXI D,BCDSAV BCD NUMBERS TO BE SENT
MVI B,COUNT  NUMBER OF CHARACTERS TO BE SENT

OUTLOP LDAX D
CALL OUTCHR  SEND THE NUMBER
INX D       DE POINTS NEXT NUMBER TO BE SENT
DCR B       COUNT
JNZ OUTLOP  IF NOT END OF CHARACTERS YET
JMP START   GO TO WAIT FOR NEXT ENTRY

CR EQU 13
LF EQU 10
BSY EQU 40H
WRK EQU 80H
DP EQU BCDSAV-4
DECIM EQU BCDSAV-5
COUNT EQU 6

```

INPUT AND OUTPUT ROUTINE ADDRESSES  
AND THE PORT ADDRESSES HAVE TO BE  
SPECIFIED BY THE USER

THIS SUBROUTINE PERFORMS 12 BIT  
BINARY TO BCD CONVERSION

BIDE MVI B,3 COUNTER  
PUSH B SAVE COUNTER  
PUSH H SAVE NUMBER TO BE CONVERTED  
LXI H,TABLO TABLE OF CONSTANTS  
NXTNO MOV B,M GET THE CONSTANT IN BC  
INX H  
MOV C,M  
INX H  
XTHL TAKE NUMBER IN HL AGAIN  
MVI A,-1 BCD NUMBER COUNTER  
NXTLOP INR A  
DAD B SUBTRACT CONSTANT FROM HL  
JC NXTLOP IF NEGATIVE NUMBER NOT FOUND YET  
ADI 30H ASCII OF THE BCD NUMBER FOUND  
STAX D STORE IN (DE)  
INX D NEXT LOCATION TO BE STORED IN  
XRA A  
SUB C  
MOV C,A  
MVI A,0  
SBB B  
MOV B,A NEGATIVE OF THE CONSTANT CALCULATED  
DAD B PREVIOUS NUMBER OBTAINED IN HL  
POP B TABLE ADDRESS TO BC

XTHL	COUNTER TO H
DCR H	COUNT
XTHL	
PUSH B	
XTHL	RETURN TO ORIGINAL POSITION
JNZ NXTNO	IF NOT END OF CONVERSION
POP H	
POP B	ADJUST STACK
MOV A,L	LEAST SIGNIFICANT DIGIT
ADI 30H	ASCII EQUIVALENT
STAX D	STORE
RET	

TABLO BYTE ECH,18H  
 BYTE FFH,9CH  
 BYTE FFH,F6H

## REFERENCES

- MORRIS, NOEL (1974) Advanced Industrial Electronics,  
Mc Graw Hill
- NICHOLSON, P.W (1974) Nuclear Electronics , Wiley
- MILLMAN, J-HALKIAS, C.C. (1972) Integrated Electronics,  
Mc Graw Hill
- HENRY, T. (1974) Successive Approximation A/D conversion,  
Motorola Application Note AN-716
- DUMORTIER, D. (1979) Digital/Analog and Analog/Digital  
Conversion Handbook, Motorola Semiconductors
- DATEL INTERSIL Data Acquisition Component Handbook
- ANALOG DEVICES Data Acquisition Components and Systems